

# **INSTALLATION INSTRUCTIONS**

## **MODELS**

**CRV-2**

**CRV-3**

## **COMMERCIAL ROOM VENTILATORS WITH EXHAUST**

**FOR USE WITH BARD 1-1/2 THRU 3 TON  
WALL MOUNT AIR CONDITIONERS  
AND HEAT PUMPS**

**DATE: 04-12-94**

**MANUAL 2100-206 REV. C  
SUPERSEDES REV. B  
FILE VOL. III, TAB 19**

## TABLE OF CONTENTS

General Information . . . . .	1
Unpacking . . . . .	1
Description . . . . .	1
Basic Installation . . . . .	1
Blade Adjustment for Desired Ventilator Air . . . . .	7
Wiring Diagram . . . . .	7
Features . . . . .	14
Sequence of Operation . . . . .	15

## FIGURES and TABLES

Figure 1 . . Wall Mount Unit . . . . .	2
Figure 2 . . Filter and Exhaust Cover Plate . . . . .	3
Figure 3 . . Wire Routing and Economizer Positioning . . . . .	4
Figure 4 . . Motor/Damper Adjustment . . . . .	5
Figure 5 . . Wire Diagram . . . . .	7
Figure 6 . . Damper Position--Vent Mode (Open) . . . . .	14
Figure 7 . . Damper Position--Closed . . . . .	15
Table 1 . . CRV-2 Ventilation Air Tables . . . . .	8
Table 2 . . CRV-2 Free Blow Ventilation Air Table . . . . .	9
Table 3 . . CRV-2 Total Available Airflow Table . . . . .	10
Table 4 . . CRV-3 Ventilation Air Tables . . . . .	11
Table 5 . . CRV-3 Free Blow Ventilation Air Table . . . . .	13
Table 6 . . CRV-3 Total Available Airflow Table . . . . .	13

Manufactured under U.S. patent number 5,301,744.  
Other patents pending.

COPYRIGHT APRIL, 1994  
BARD MANUFACTURING COMPANY  
BRYAN, OHIO USA 43506

## GENERAL INFORMATION

The ventilator should only be installed by a trained heating and air conditioning technician. These instructions serve as a guide to the technician installing the ventilator package. They are not intended as a step by step procedure with which the mechanically inclined owner can install the package.

The ventilator housing is shipped in one carton which contains the electrical harness, miscellaneous hardware and installation instructions.

## UNPACKING

Upon receipt of the equipment, be sure to compare the model number found on the shipping label with the accessory identification information on the ordering and shipping document to verify that the correct accessory has been shipped.

Inspect the carton housing of each ventilator as it is received, and before signing the freight bill, verify that all items have been received and that there is no visible damage. Note any shortages or damage on all copies of the freight bill. The receiving party must contact the last carrier immediately, preferably in writing, requesting inspection by the carrier's agent. Concealed damage not discovered until after loading must be reported to the carrier within 15 days of its receipt.

## DESCRIPTION

The CRV-2, 3 and 5 ventilators are designed to be used with Bard 1-1/2 thru 5 ton wall mount series air conditioners and heat pumps. They are electro-mechanical vent systems designed to provide fresh air to meet indoor air quality standards with built in exhaust provisions.

## BASIC INSTALLATION

1. Unpack the ventilator assembly which includes the integral ventilator with attached electrical harness and miscellaneous hardware.

WARNING	
Open and lock unit disconnect switch before installing this accessory to prevent injury or death due to electrical shock or contact with moving parts. Turn thermostat to off.	

<u>MODEL</u>	<u>For Use With Following Units</u>
CRV-2	WA181 WE181 WA241 WE241
CRV-3	WA301 WE301 WA361 WE361
CRV-5	WA421 WE421 WA481 WE481 WA601 WE601

2. Remove and save the existing exterior blower access and service access panels on the Bard wall mount units. (See Figure 1)

FIGURE 1

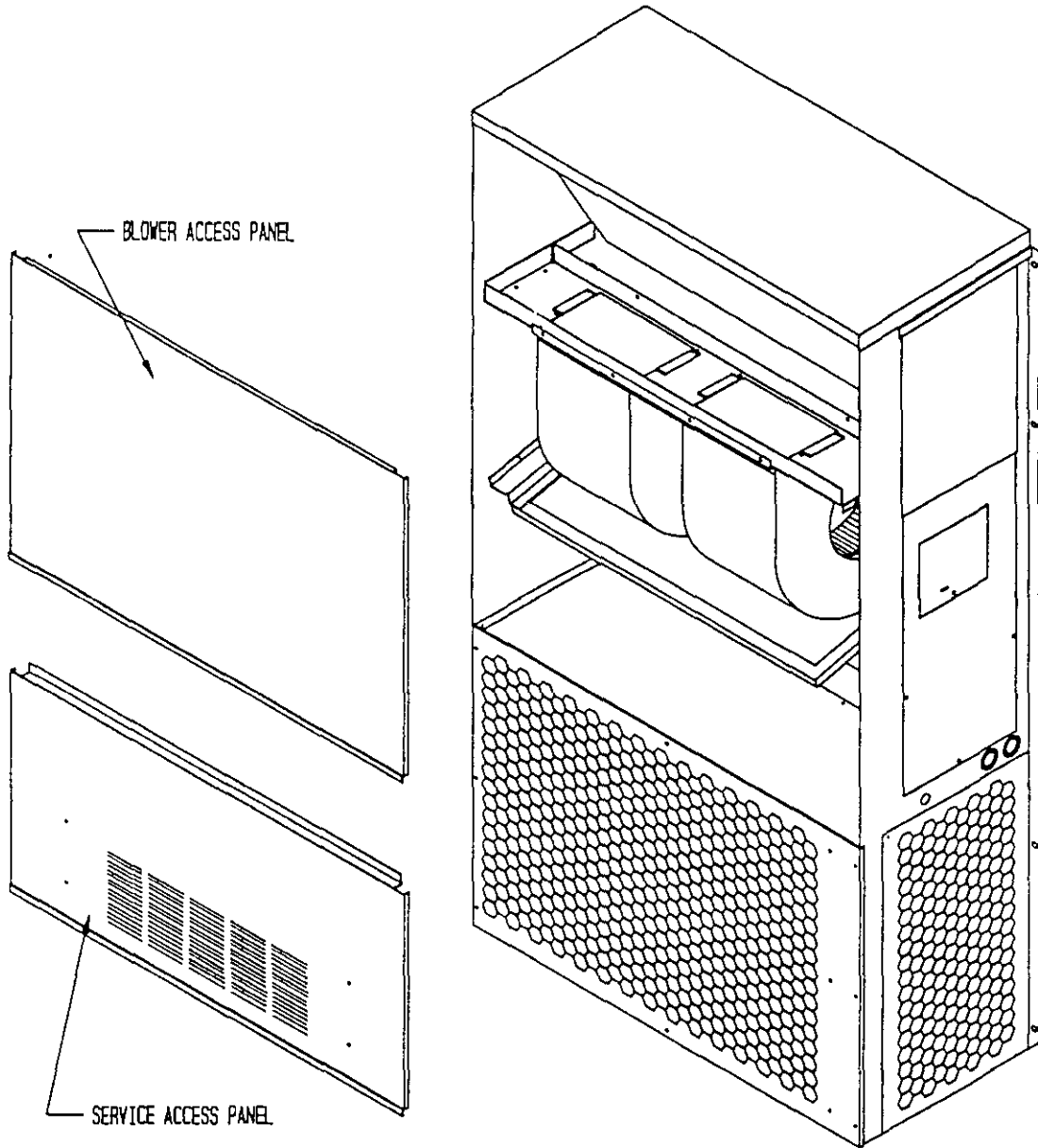

3. Remove and save existing unit return air filter and left side filter support bracket by removing two screws from left side of unit. Remove and save top four (4) screws from front grille. (See Figure 2)

FIGURE 2

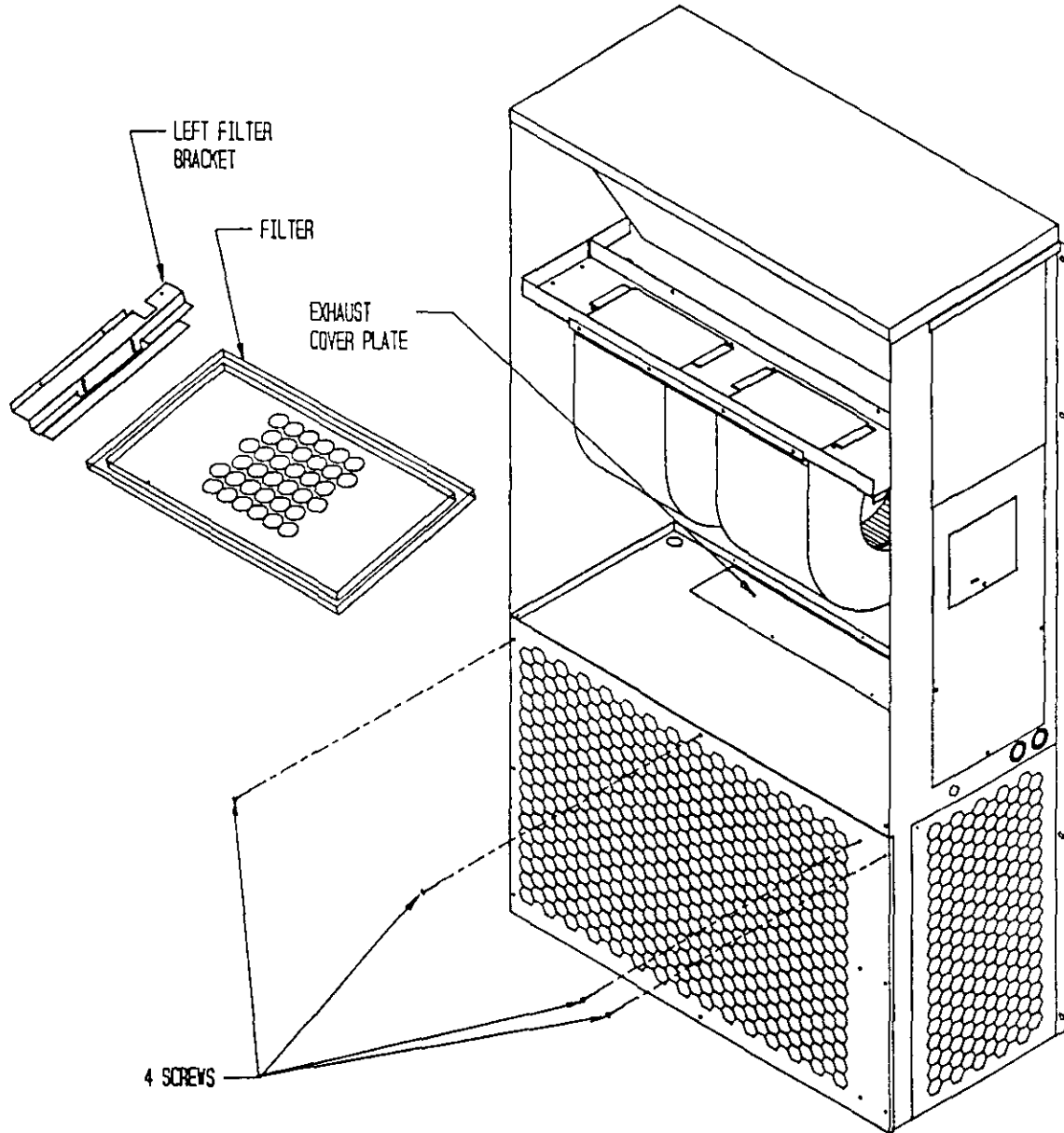

FIGURE 3

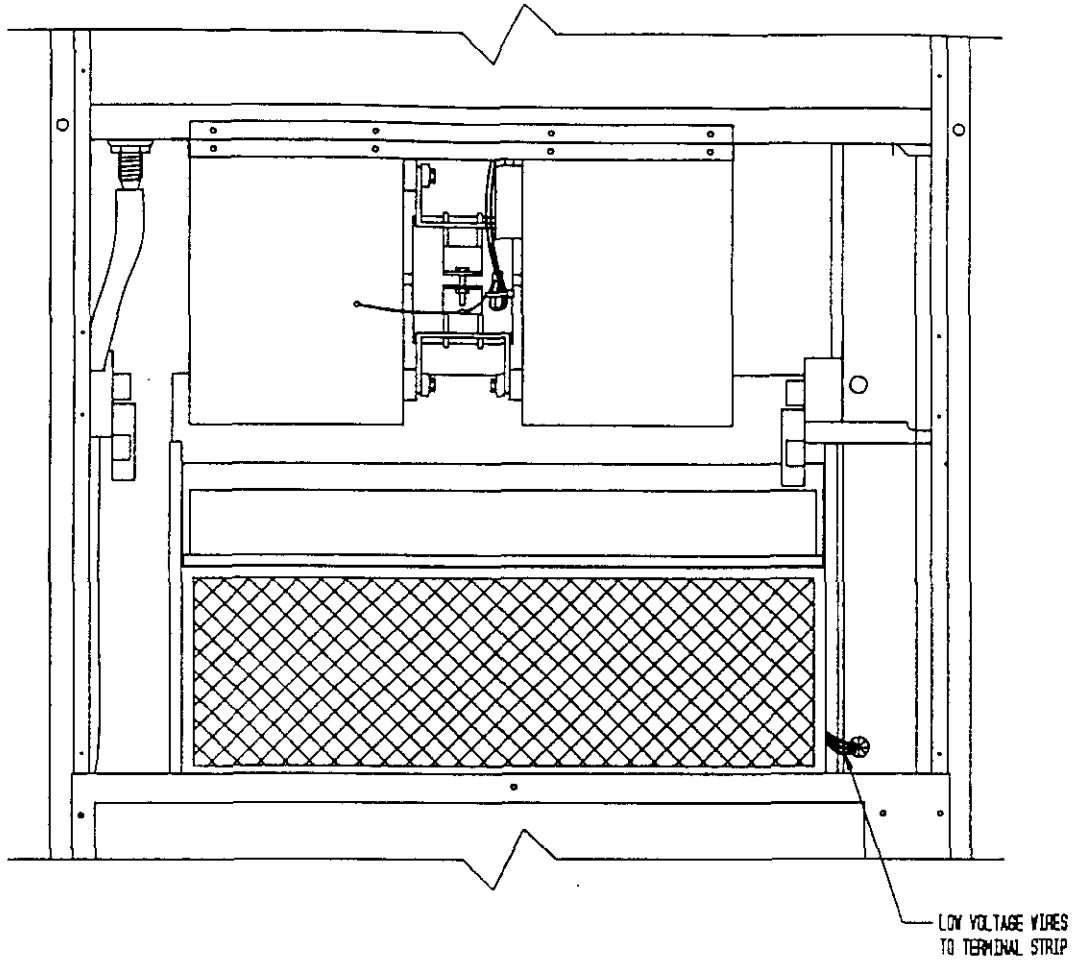

FIGURE 3  
INSET

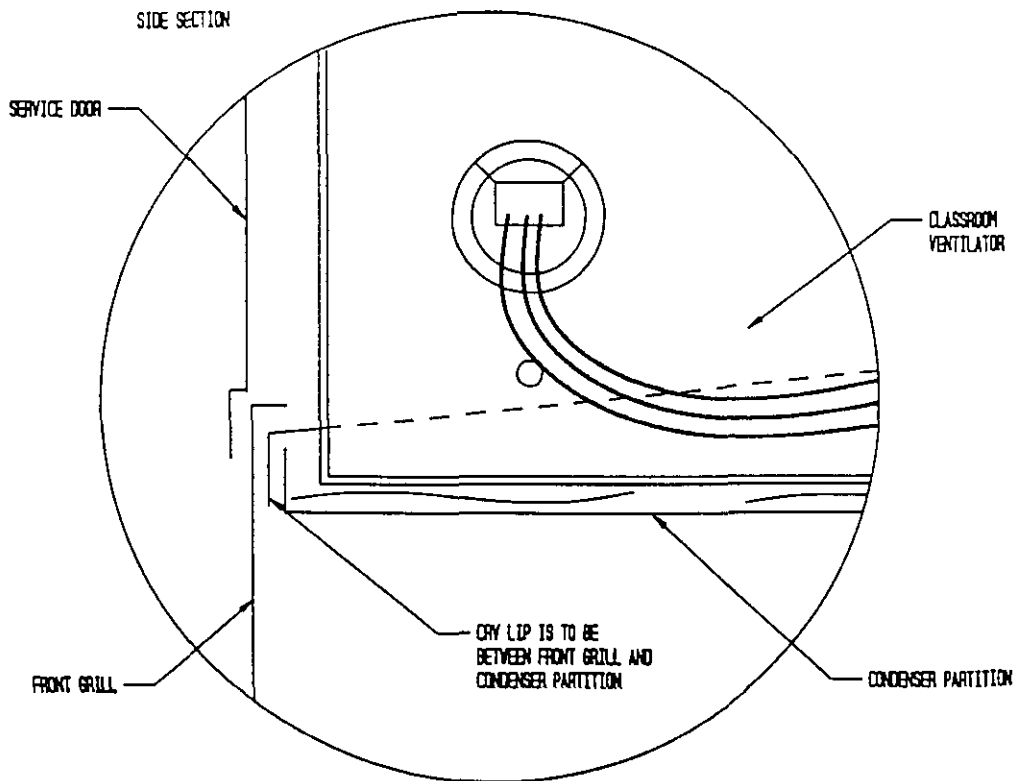
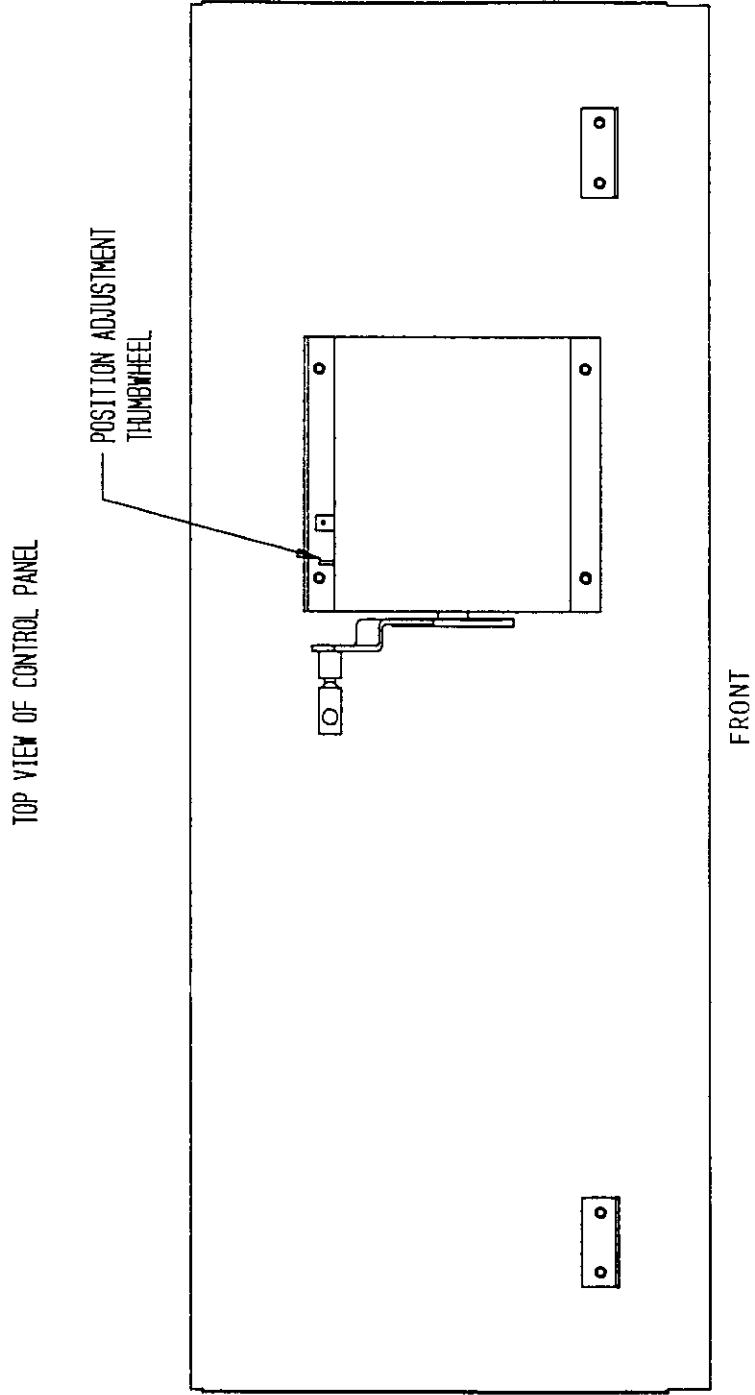

FIGURE 4



NOTE: Rotate thumbwheel up to open, down to close.

4. Remove and discard the exhaust cover plate. (Figure 2)
5. Install ventilator by inserting the ventilator into the unit to the far left side clearing the right filter bracket. Once the ventilator is fully inserted, slide the ventilator to the right until it is tight against the back of the control panel. (Figure 3)  
  
IMPORTANT: Position front lip of ventilator under front grille and on top of condenser partition. (See Figure 3 inset) This is important to ensure proper drainage of any water entering damper assembly.
6. Open control panel to gain access to unit low voltage terminal block.
7. Route electrical harness leads thru the 7/8" bushing in control panel (Figure 3) into low voltage box.
8. Connect leads with fork terminal to corresponding points on terminal strip to terminals C and G. (See wiring diagram, Figure 5, on Page 7 or on ventilator.)
9. Close control panel cover
10. Replace left filter support, filter and four (4) screws in condenser grille.
11. Reinstall the blower access panel at top of unit and secure with sheet metal screws.
12. Ventilator Checkout
  - A. Remove mist eliminator to allow access to minimum position thumbwheel. (See Figures 3 and 4)
  - B. Resupply power to unit.
  - C. Energize the evaporator blower by switching thermostat to the manual fan position with heat/cool in off position.
  - D. Ventilator should open to the position set by position adjustment thumbwheel. Cycle position adjustment thumbwheel to full open through full close. Observe damper blade operation throughout travel to assure free, unobstructed movement. (See Figure 4)
  - E. Adjust position adjustment thumbwheel until desired blade setting is reached with power applied to unit. See Tables 1 - 6 for required blade setting versus ventilator air.
  - F. De-energize evaporator blower. Damper blade should close.
  - G. This completes ventilator checkout.
13. Replace mist eliminator. Be sure it is installed with the drainholes to the bottom.
14. Remove blank off plate or barometric fresh air damper installed on service access door. Plug 4 mounting holes with the plastic plugs provided with the ventilator.
15. Replace service access panel.
16. Ventilator is now ready for operation.



## BLADE ADJUSTMENT FOR DESIRED VENTILATOR AIR

The amount of ventilation air supplied by the commercial room ventilator is dependent on 4 factors.

1. Return air duct static pressure drop.
2. Supply air duct static pressure drop.
3. Indoor blower motor speed.
4. Damper blade open position setting.

To determine the amount of fresh air that will be supplied to the structure first, determine the pressure drops of the supply and return air ducts. For free blow application with return air filter grill and supply grill, assume .05 supply static, .10 return static. See applicance Table 3 or 6.

Determine on what speed the evaporator motor is running at.

Refer to the tables on the next 5 pages to determine the blade setting necessary to achieve the ventilation air required at the supply and return static duct pressures drops that are applicable.

FIGURE 5

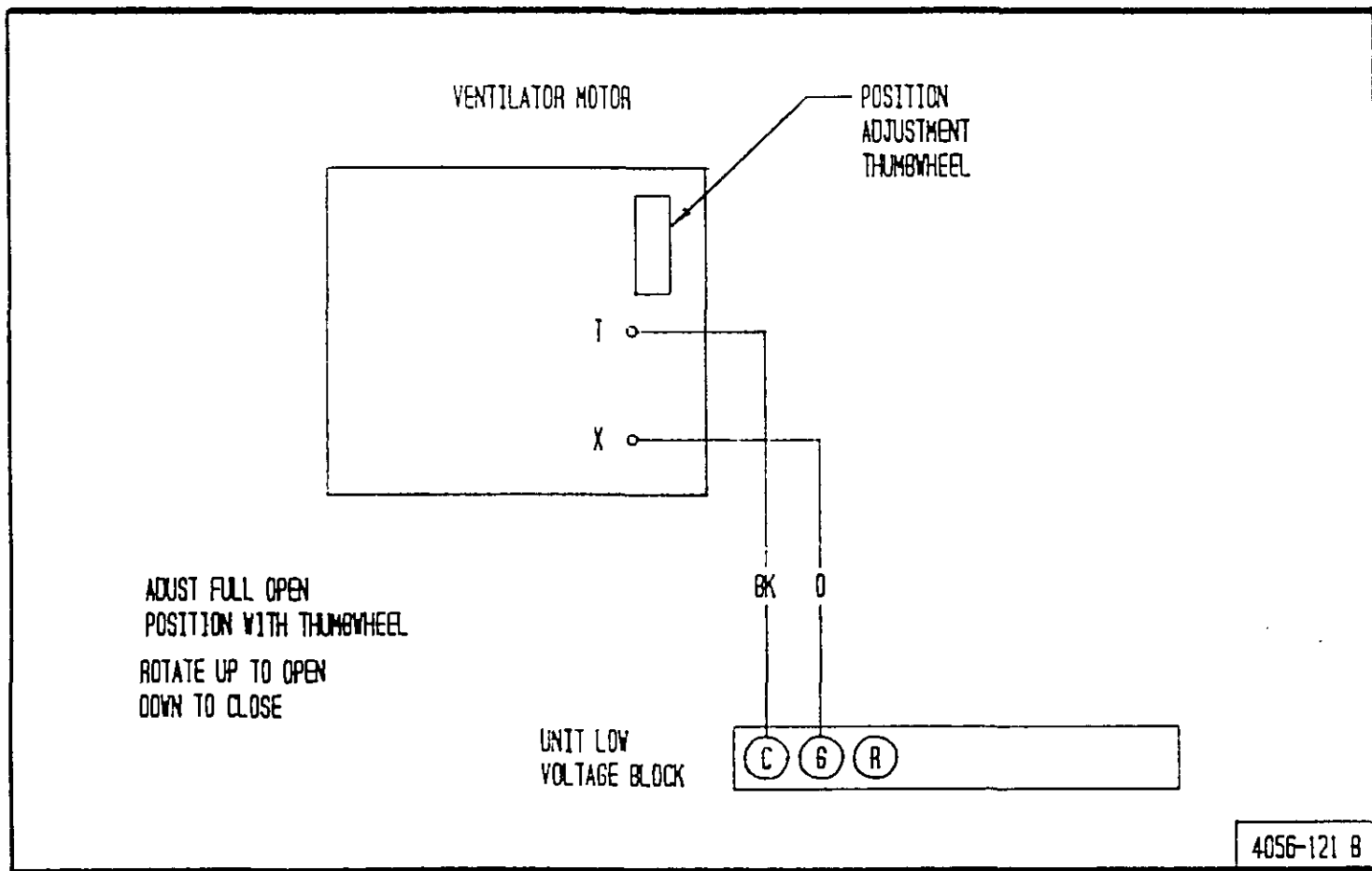

COMMERCIAL ROOM VENTILATOR--CRV-2  
 VENTILATION AIR WITH DUCTED SYSTEM

TABLE 1

		0.00 SUPPLY AIR STATIC						
		Ventilation Air (CFM)						
Damper Position	A	120	145	175	210	245	275	305
	B	175	195	220	250	280	309	335
	C	225	245	260	290	320	340	360
	D	285	300	310	325	345	360	380
	E	345	355	360	365	370	385	400
Return Static Pressure		0	.05	.10	.15	.20	.25	.30

		0.10 SUPPLY AIR STATIC						
		Ventilation Air (CFM)						
Damper Position	A	110	145	175	210	240	275	310
	B	165	185	215	245	270	300	330
	C	210	230	250	280	305	330	350
	D	265	280	290	310	330	345	365
	E	320	330	335	345	355	365	380
Return Static Pressure		0	.05	.10	.15	.20	.25	.30

		0.20 SUPPLY AIR STATIC						
		Ventilation Air (CFM)						
Damper Position	A	103	140	177	206	234		
	B	150	179	209	235	262		
	C	197	219	240	265	290		
	D	247	260	273	293	313		
	E	296	301	305	320	335		
Return Static Pressure		0	.05	.10	.15	.20	.25	.30

TABLE 1 (continued)

		0.30 SUPPLY AIR STATIC						
		Ventilation Air (CFM)						
Damper Position	A	95	135	175				
	B	135	165	200				
	C	175	200	220				
	D	221	235	250				
	E	268	275	280				
Return Static Pressure		0	.05	.10	.15	.20	.25	.30

		0.40 SUPPLY AIR STATIC						
		Ventilation Air (CFM)						
Damper Position	A	87						
	B	120						
	C	152						
	D	196						
	E	239						
Return Static Pressure		0	.05	.10	.15	.20	.25	.30

**NON-DUCTED BLOW APPLICATION VENTILATION AIR  
WITH RETURN AIR FILTER GRILL AND SUPPLY AIR GRILL**

TABLE 2

		Ventilation Air (CFM)						
Damper Position	A	175						
	B	215						
	C	255						
	D	300						
	E	345						

CRV-2 TOTAL DELIVERED AIR

TABLE 3

		Ventilation Air (CFM)				
Damper	Close	1006	946	886	789	691
Position	A	1001	943	884	785	685
	B	990	931	873	775	677
	C	978	920	862	765	668
	D	945	888	832	738	645
	E	912	857	801	711	621
Return Static Pressure		0	.10	.20	.30	.40

**COMMERCIAL ROOM VENTILATOR--CRV-3  
VENTILATION AIR WITH DUCTED SYSTEM**

TABLE 4

HIGH SPEED BLOWER		0.10 SUPPLY AIR STATIC						
		Ventilation Air (CFM)						
Damper	A	130	150	180	225	275	320	365
Position	B	220	240	265	300	340	375	410
	C	310	325	350	375	400	425	450
	D	390	405	420	440	450	470	485
	E	470	480	485	495	505	515	520
Return Static Pressure		0	.05	.10	.15	.20	.25	.30

HIGH SPEED BLOWER		0.20 SUPPLY AIR STATIC						
		Ventilation Air (CFM)						
Damper	A	115	140	180	225	280	325	365
Position	B	205	230	255	295	335	370	405
	C	290	310	335	360	385	410	440
	D	365	382	400	415	425	445	470
	E	435	445	450	460	465	480	490
Return Static Pressure		0	.05	.10	.15	.20	.25	.30

HIGH SPEED BLOWER		0.30 SUPPLY AIR STATIC						
		Ventilation Air (CFM)						
Damper	A	110	140	180	235	290		
Position	B	185	215	250	290	330		
	C	260	285	315	340	405		
	D	330	350	370	385	400		
	E	400	410	415	430	435		
Return Static Pressure		0	.05	.10	.15	.20	.25	.30

HIGH SPEED BLOWER		0.40 SUPPLY AIR STATIC						
		Ventilation Air (CFM)						
Damper	A	100	140	180				
Position	B	160	200	240				
	C	225	260	295				
	D	295	315	340				
	E	365	370	380				
Return Static Pressure		0	.05	.10	.15	.20	.25	.30

TABLE 4 (continued)

LOW SPEED BLOWER		0.00 SUPPLY AIR STATIC						
		Ventilation Air (CFM)						
Damper	A	100	135	175	225	275		
Position	B	165	205	245	285	325		
	C	240	275	310	345	375		
	D	315	345	375	400	415		
	E	400	420	440	450	455		
Return Static Pressure		0	.05	.10	.15	.20	.25	.30

LOW SPEED BLOWER		0.10 SUPPLY AIR STATIC						
		Ventilation Air (CFM)						
Damper	A	100	135	180	225	280		
Position	B	160	200	240	280	325		
	C	230	265	300	335	370		
	D	310	335	360	285	405		
	E	395	410	425	430	435		
Return Static Pressure		0	.05	.10	.15	.20	.25	.30

LOW SPEED BLOWER		0.20 SUPPLY AIR STATIC						
		Ventilation Air (CFM)						
Damper	A	100	140	190	240	295		
Position	B	160	200	245	290	330		
	C	220	260	300	330	360		
	D	290	320	350	370	390		
	E	365	380	394	405	420		
Return Static Pressure		0	.05	.10	.15	.20	.25	.30

**NON-DUCTED BLOW APPLICATION VENTILATION AIR  
WITH RETURN AIR FILTER GRILL AND SUPPLY AIR GRILL**

TABLE 5

		Ventilation Air (CFM)	
		High Speed	Low Speed
Damper Position	A	180	175
	B	265	245
	C	360	305
	D	430	370
	E	495	450

**CRV-3 TOTAL DELIVERED AIR**

TABLE 6

HIGH SPEED BLOWER		TOTAL DELIVERED AIR (CFM)					
Damper Position	Close	1370	1300	1230	1133	1035	935
	A	1360	1293	1225	1124	1022	920
	B	1355	1289	1223	1119	1016	913
	C	1350	1285	1220	1115	1010	905
	D	1325	1258	1190	1085	980	875
	E	1300	1230	1160	1055	950	845
Total Static Pressure		0	.10	.20	.30	.40	.50

LOW SPEED BLOWER

		Total Delivered Air (CFM)				
Damper Position	Close	1027	1009	990	930	869
	A	1016	998	979	918	856
	B	994	984	972	907	841
	C	972	969	966	896	825
	D	962	945	928	856	783
	E	951	921	890	816	741
Total Static Pressure		0	.05	.10	.15	.20

## COMMERCIAL ROOM VENTILATOR -- (WA & WH Series)

### Features:

- One piece construction--easy to install with no mechanical linkage adjustment required.
- Exhaust air damper--built in with positive closed position. Provides exhaust air capability to prevent pressurization of tight buildings.
- Actuator motor--24 volt, power open, spring return with built in torque limiting switch.
- Provides up to 75 percent of outside air.

### Commercial Room Ventilator Sequence of Operation

On a call for blower operation, CRV opens to full open position as set by minimum position potentiometer. See Figure 6.

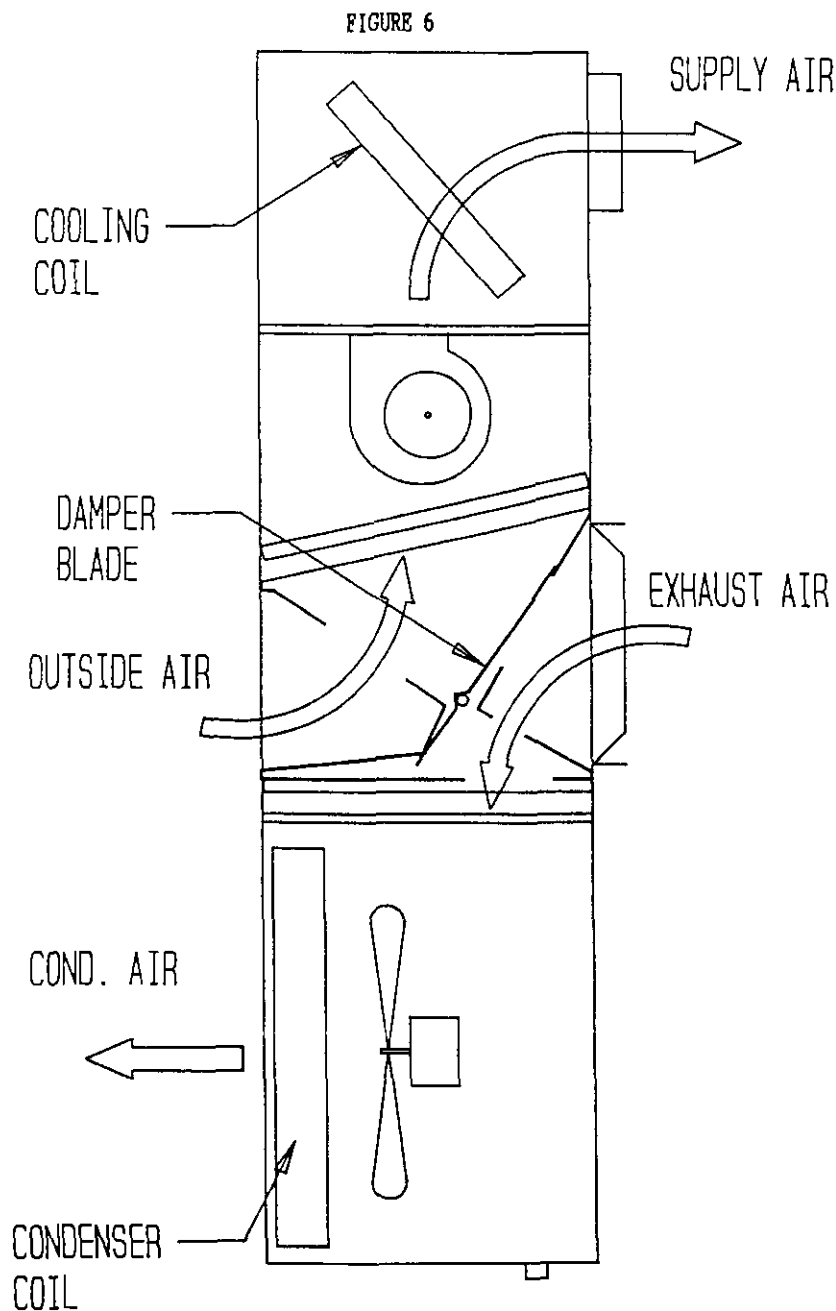



A call for cooling cycles the compressor and dampers remain in the ventilation mode. On loss of blower operation, CRV closes fully. See Figure 7.

FIGURE 7

