



## IMPORTANT

Installers' Information Manual, Users' Information Manual, Wiring Diagram, Parts List and Warranty are inside or attached and should be read before the Installation is started or before service is attempted.

After factory final assembly, this furnace has been dielectrically tested. Operation tests have been performed on the burners, fan control and blower motor.

**- TO THE INSTALLER -  
AFFIX THIS PACKET ADJACENT TO  
THE FURNACE.**

**- TO THE OWNER -  
RETAIN THIS PACKET AND ITS CONTENTS FOR  
FURTHER REFERENCE.**

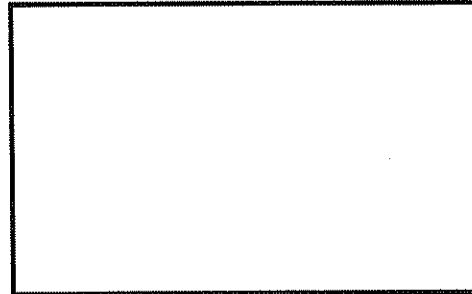

### TABLE OF CONTENTS:

### PAGE

#### INSTALLERS' MANUAL

INSTALLERS' INFORMATION MANUAL  
GAMA VENTING TABLES ADDENDUM  
SIDEWALL VENTING ADDENDUM

1-35  
36-62  
63-68

#### USER'S MANUAL

(PRINTED IN RED AND BLACK AND INSERTED IN THE CENTER OF THIS PACKET.)

# PARTS

## FUNCTIONAL PARTS LIST

The format of this parts list allows you to get the part number quickly. It allows you to easily identify the part and the part number. Propane Conversion Kit and Filter Frames are also listed in the parts list.

If you do not know the part number, find the part illustration to the left and note the illustration number. Locate the illustration number in the Parts List on the back foldout of this packet. Read across the list to locate the part number for the appropriate size furnace.

**EXAMPLE:** You need an inducer motor relay for a 60,000 BTUH input 1/3 H.P. furnace:

1. Find the inducer motor relay in the illustration and get the illustration number (in this case 13).
2. Go to the table and read down to illustration number 13.
3. Read across the row to find the part number for the 60,000 BTUH input 1/3 H.P. furnace.
4. Read part number 9043-316.

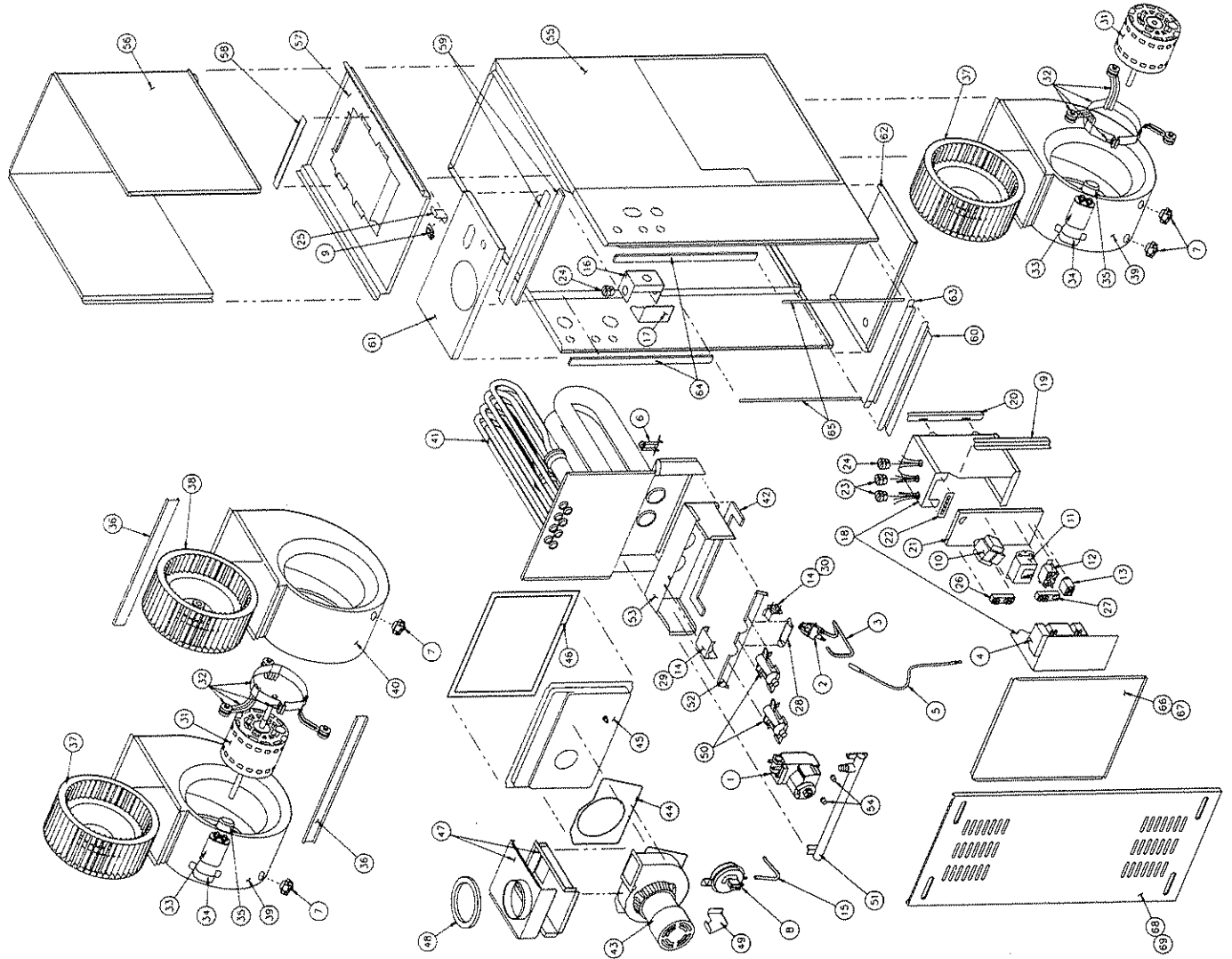



To assure both safe and proper operation, please carefully follow the instructions in this manual to correctly install this new furnace.

**ATTENTION, INSTALLER!** After installing furnace, give the user:

- Users' Information Manual
- Parts List
- Installers' Information Manual
- Warranty Information

**ATTENTION, USER!** Your furnace installer should give you the above four important documents relating to your furnace. Keep these as long as you keep your furnace. Pass these documents on to later furnace purchasers or Users'. If any of the four documents is missing or damaged, contact your installer or furnace manufacturer for replacement. For efficient service, please give your furnace model and serial number, listed in Section 1 of your Users' Information Manual or from your furnace rating plate. Throughout this Installers' Information Manual, we frequently use the word "you" when referring to the person responsible for application, installation and service of your furnace. Please remember to have only qualified service technicians perform these services.

**WARNING:** Individuals who install this furnace, must have the training and experience necessary to install gas furnaces. They must also have training and experience necessary to install related comfort air conditioning appliances. Improper installation could create a hazard, resulting in damage, injury or death.

While we have written these instructions as accurately and thoroughly as possible, they may not cover every system variation or contingency. Also, questions of interpretation may arise. For more information, solutions to particular problems or clarification, contact your local distributor or the manufacturer. See the furnace rating plate for who to contact.

Furnace installation must follow all applicable NATIONAL, STATE and LOCAL CODES.

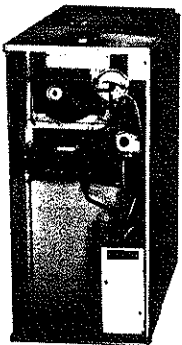

UPFLOW

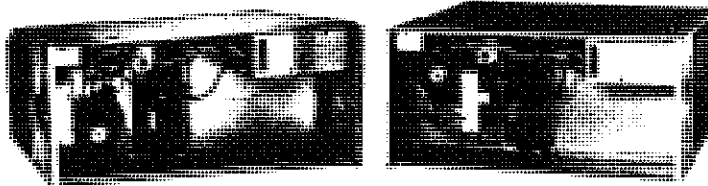

HORIZONTAL

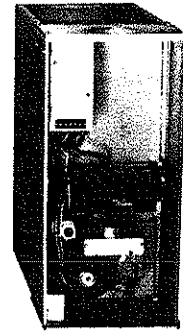

DOWNFLOW

ELECTRONIC IGNITION INDUCED DRAFT FURNACE

**WARNING: FOR YOUR SAFETY, WHAT TO DO IF YOU SMELL GAS:**

- DO NOT TRY TO LIGHT ANY APPLIANCE;
- DO NOT TOUCH ANY ELECTRICAL SWITCH; DO NOT USE ANY PHONE IN THE BUILDING;
- IMMEDIATELY CALL YOUR GAS SUPPLIER FROM A NEIGHBOR'S PHONE; FOLLOW GAS SUPPLIER'S INSTRUCTIONS;
- IF YOU CANNOT REACH GAS SUPPLIER, CALL FIRE DEPARTMENT.

**IMPORTANT SAFETY NOTE:** After installing the furnace, show the user how to turn off gas and electricity to furnace. Point out control and switch locations for turning off gas and electricity. Go over Sections 4 and 6 of Users' Information Manual and Section 29 in this manual with user. Make sure user understands the importance of following all safety precautions.

SECTION	TABLE OF CONTENTS		PAGE
SECTION 1	PREPARING TO INSTALL FURNACE .....		2
SECTION 2	IMPORTANT SAFETY RULES .....		3
SECTION 3	MEETING CODES .....		3
SECTION 4	DETERMINING BEST FURNACE LOCATION.....		3
SECTION 5	IDENTIFYING FURNACE DIMENSIONS, SPECIFICATIONS, AND POSITION .....		4
SECTION 6	ALLOWING FOR CLEARANCES .....		7
SECTION 7	SUSPENDING FURNACE .....		8
SECTION 8	PROVIDING FOR COMBUSTION AND VENTILATION AIR .....		9
SECTION 9	PROVIDING FOR PROPER VENTING .....		13
SECTION 10	TOOLS NEEDED FOR INSTALLATION.....		17
SECTION 11	INSTALLING GAS PIPING .....		18
SECTION 12	INSTALLING ELECTRICAL WIRING.....		19
SECTION 13	FOLLOWING FIELD WIRING DIAGRAMS.....		19
SECTION 14	ADJUSTING ROOM THERMOSTAT HEAT ANTICIPATOR.....		19
SECTION 15	SEQUENCE OF OPERATION.....		20
SECTION 16	INSTALLING DUCT WORK .....		20
SECTION 17	SELECTING AND INSTALLING FILTER FRAMES .....		23
SECTION 18	CHECKING BEFORE STARTING FURNACE .....		25
SECTION 19	ADJUSTING PILOT.....		25
SECTION 20	ADJUSTING MANIFOLD PRESSURE.....		26
SECTION 21	CHECKING GAS INPUT .....		27
SECTION 22	ORIFICE SIZE .....		29
SECTION 23	DERATING FOR HIGH ALTITUDES .....		29
SECTION 24	ADJUSTING BLOWER SPEED.....		30
SECTION 25	MEASURING DUCT WORK STATIC PRESSURE .....		31
SECTION 26	MEASURING AIR TEMPERATURE RISE .....		32
SECTION 27	CHECKING CONTROLS .....		33
SECTION 28	BLOWER TIMINGS .....		33
SECTION 29	MAINTAINING FURNACE IN GOOD WORKING ORDER.....		34
SECTION 30	GETTING OTHER INFORMATION AND PUBLICATIONS .....		34

**SECTION 1 —  
PREPARING TO INSTALL FURNACE.**

**A. Literature.**

Review this manual, Users' Information Manual and Parts List. In particular, see User's Information Manual and Parts List for location and identification of furnace components.

After installing furnace, give this Installers' Information Manual, Users' Information Manual, Warranty and Parts List to user. You may have questions as you install the furnace. If you need help on any of the installation instructions or other matters relating to the furnace, contact the office where you bought the furnace. You may also refer to the furnace rating plate for a contact name.

**B. Installation Positions.**

1. You may install furnace as-shipped in an upflow or horizontal configuration in one of three positions shown in Figure 1.

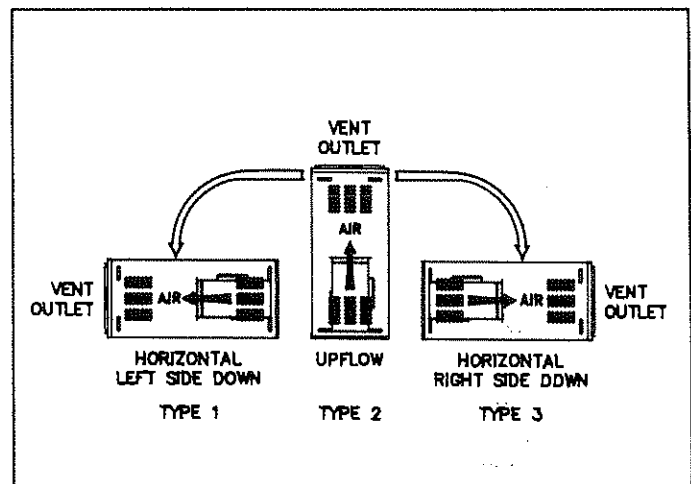

**FIGURE 1**

2. You may convert furnace quickly and easily from its as-shipped configuration. After conversion, you can install it as a downflow or horizontal furnace in one of three positions shown in Figure 2.

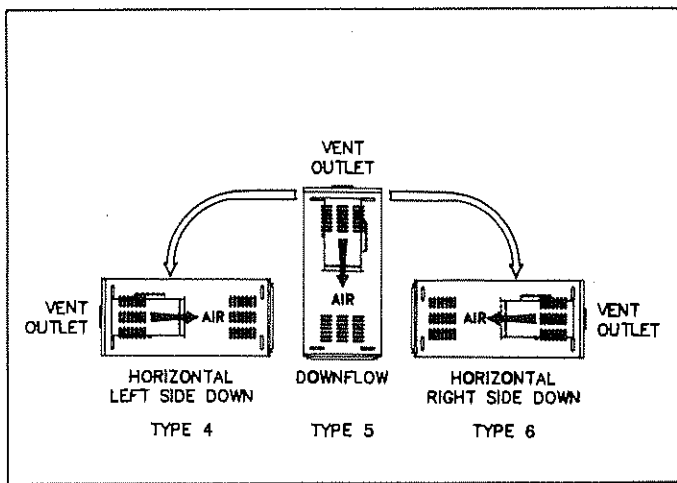

FIGURE 2

## SECTION 2 — IMPORTANT SAFETY RULES.

**WARNING:** Read and exactly follow these rules. Failure to do so could cause improper furnace operation, resulting in damage, injury or death.

### A. Signal words.

To alert you to potential hazards, we use the signal words "**WARNING**" and "**CAUTION**" throughout this manual. "**WARNING**" alerts you to situations that could cause serious injury or death. "**CAUTION**" alerts you to situations that could cause minor or moderate injury or property damage. To help you, we use the words "must" and "should" in this manual. "Must" is mandatory. "Should" is advisory.

- B. Use only the type of gas approved for this furnace; refer to furnace rating plate.

**WARNING:** Only use natural gas in furnaces designed for natural gas. Only use Propane (LP) gas for furnaces designed for Propane (LP) gas. Make sure furnace will operate properly on gas type available to user. Do not use this furnace with butane. Using wrong gas could create a hazard, resulting in damage, injury, or death.

- C. **DO NOT** install this furnace outdoors or in a mobile home, trailer or recreational vehicle. It is not A.G.A. design-certified for these installations. This furnace is suitable for a home built on site or manufactured home completed at final site.
- D. Carefully choose furnace installation site. **DO NOT** directly expose furnace to drafts, wind or other outdoor conditions. See Section 8 for more information.
- E. **DO NOT** install furnace in a corrosive or contaminated atmosphere. Make sure all combustion and ventilation air requirements are adhered to in addition to local codes and ordinances. See Section 8 for more information.
- F. **DO NOT** use this furnace during construction when adhesives, sealers, and/or new carpets are being installed. If the furnace must be used during construction, provide clean outdoor air for combustion and ventilation to furnace space. See Section 8 for more information.

- G. Provide adequate combustion and ventilation air to space where furnace is being installed. See Section 8 for more information. Connect this furnace to an approved vent system, venting combustion products outdoors. See Section 9 for more information.
- H. Never test for gas leaks with an open flame. Use a commercial soap made specifically for leak detection to check all connections. See Section 11 for more information.
- I. Always install duct system with furnace. Be sure duct system has external static pressure within allowable furnace range. See Sections 16 and 25 for more information.
- J. Completely seal supply and return air ducts to furnace casing. Duct work must run to an area outside furnace air space. Seal duct work wherever it runs through walls, ceilings or floors. See Section 16 for more information.

## SECTION 3 — MEETING CODES.

Before installing furnace, make sure you know all applicable codes. National, state and local codes may take precedence over any instructions in this manual. Be sure to consult:

- Authorities having jurisdiction over furnaces;
- Local code authorities for information on electrical wiring, gas piping and vent pipe;
- Current National Fuel Gas Code ANSI Z223.1/NFPA 54;
- Current National Electrical Code ANSI/NFPA 70.

See Section 30 for information on getting copies of these codes.

## SECTION 4 — DETERMINING BEST FURNACE LOCATION.

You may install this furnace as an upflow or downflow furnace in an alcove, attic, basement, closet, garage, or utility room. Install furnace so all electrical components are protected from water.

You may install it as a horizontal furnace in an alcove, garage, attic, basement or crawl space.

Select furnace location to meet all requirements in this manual, making sure to refer to:

- Section 2 for safety rules;
- Section 6 for minimum clearances;
- Section 7 for furnace suspension;
- Section 8 for combustion and ventilation air;
- Section 9 for venting;
- Section 11 for gas piping;
- Section 12 for electrical wiring;
- Section 16 and 25 for duct work;
- Section 17 for filters.

Consult local code authorities for additional location requirements.

Locate the furnace close to the chimney/vent and as near the center of the air distribution system as possible. Install furnace as level as possible.

Provide ample space for servicing and cleaning. Location must allow 30 inches minimum front clearance for service. Always comply with minimum clearances shown on inside of front door. Do not install furnace directly on carpeting, tile or any combustible material other than wood flooring.

**NOTE:** A combustible floor base, available from manufacturer, is required for downflow furnace installation on wood flooring.

**HAZARDOUS LOCATIONS.**

When furnace is in a residential garage, it must be installed so that burners and ignition source are located no less than 18-inches above the floor. Also, furnace should be protected from physical damage by vehicles.

When furnace is in public garages, airplane hangers, or other buildings having hazardous atmospheres, install unit in accordance with recommended good practice requirements of the National Fire Protection Association, Inc. See Section 30.

**SECTION 5 — IDENTIFYING FURNACE DIMENSIONS, SPECIFICATIONS, AND POSITION.**

A. A unique feature of this furnace is that it may be installed as an upflow furnace, horizontal furnace, or downflow furnace (minor conversion required).

1. Furnace as-shipped is an upflow furnace. Furnace may be installed in this position or may be installed as a horizontal on its right or left side without any conversion. See Figure 1.

2. Furnace as-shipped position may be converted to a downflow furnace by following instructions in B. below. Once conversion is complete, furnace may be installed as a downflow furnace. Furnace may also then be installed as a horizontal on its right or left side. See Figure 2.

**WARNING:** Do not install furnace on its back. Doing so could cause a fire, resulting in damage, injury or death.

See Figure 3 for dimensional drawings and specification table.

**B. Converting furnace from as-shipped configuration.**

**READ ALL INSTRUCTIONS THOROUGHLY BEFORE STARTING CONVERSION.**

**NOTE:** Start conversion with furnace on its back.

**WARNING:** When servicing controls, all wires must be labeled prior to disconnection. Miswiring can cause improper operation resulting in damage, injury, or death.

1. Remove front door. Study components described in conversion. See Figure 4.

BTUH* INPUT	MOTOR* H.P.	VENT DIAMETER	FURNACE WIDTH A	RETURN AIR SIZE 18-29/32" X B	SUPPLY AIR SIZE 18-15/16" X C	BLOWER WHEEL SIZE	TEMP RISE °F	CFM at 0.50" W.C.
40,000	1/4	3"	14-1/2	12-7/8"	12-15/16"	10-4	50-80	805
40,000	1/3	3"	14-1/2	12-7/8"	12-15/16"	10-6	30-60	1265
60,000	1/4	4"	14-1/2	12-7/8"	12-15/16"	10-4	45-75	850
60,000	1/3	4"	14-1/2	12-7/8"	12-15/16"	10-6	45-75	1260
80,000	1/2	4"	17-1/2	15-7/8"	15-15/16"	10-8	35-65	1635
80,000	1/4	4"	14-1/2	12-7/8"	12-15/16"	10-4	50-80	915
80,000	1/3	4"	14-1/2	12-7/8"	12-15/16"	10-6	40-70	1235
80,000	1/2	4"	17-1/2	15-7/8"	15-15/16"	10-8	50-80	1645
80,000	3/4	4"	20-1/2	18-7/8"	18-15/16"	(2) 10-4	40-70	1930
100,000	1/3	4"	17-1/2	15-7/8"	15-15/16"	10-6	55-85	1245
100,000	1/2	4"	17-1/2	15-7/8"	15-15/16"	10-8	50-80	1585
100,000	3/4	4"	20-1/2	18-7/8"	18-15/16"	(2) 10-4	40-70	1950
120,000	1/2	5"	20-1/2	18-7/8"	18-15/16"	10-8	45-75	1660
120,000	3/4	5"	20-1/2	18-7/8"	18-15/16"	(2) 10-4	45-75	1965
140,000	3/4	5"	23-1/2	21-7/8"	21-15/16"	(2) 10-4	45-75	1860
140,000	3/4	5"	23-1/2	21-7/8"	21-15/16"	(2) 10-6	50-80	2235

\*See Furnace rating plate located on blower door.

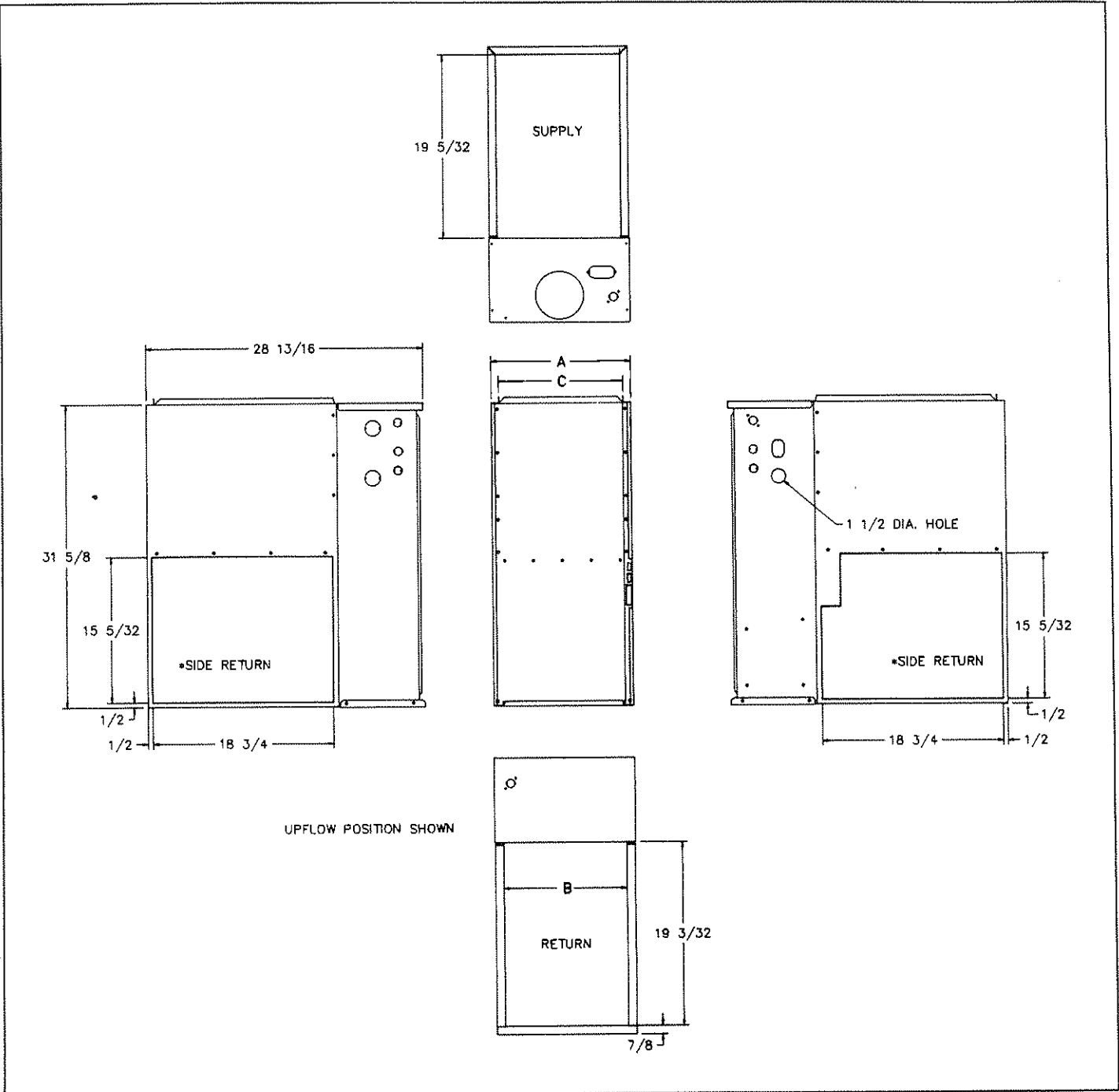

**FURNACE AND DIMENSIONS SPECIFICATIONS  
FIGURE 3**

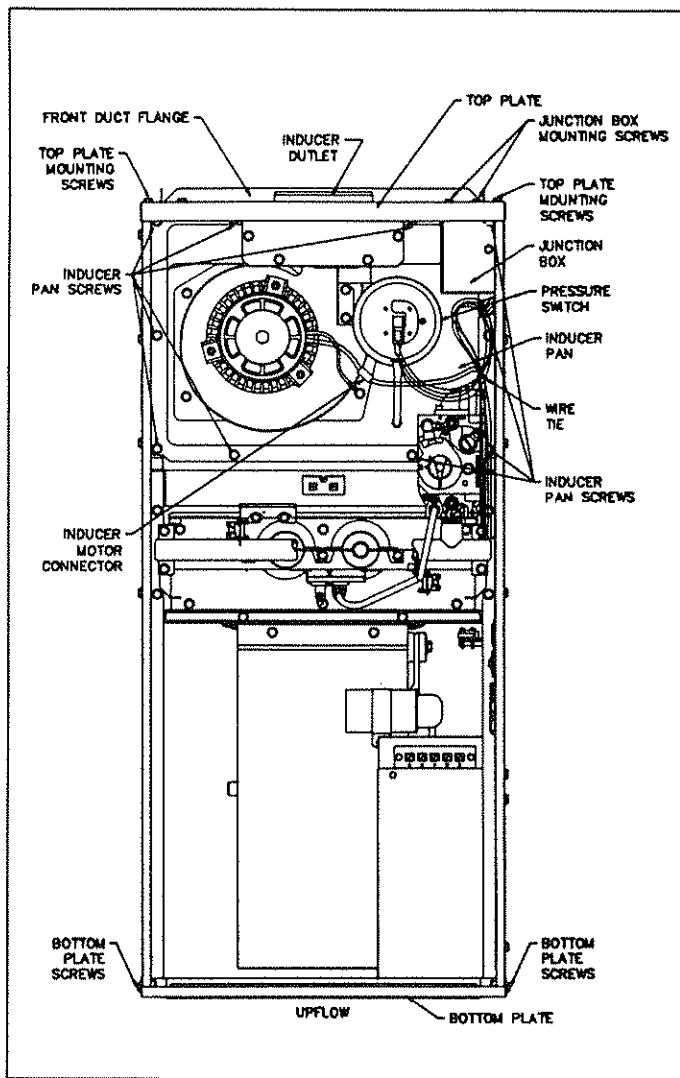

**AS-SHIPED CONFIGURATION  
FIGURE 4**

2. Remove two junction box mounting screws from top plate. Remove four top plate mounting screws. Save all screws. Remove top plate and front duct flange.
  3. Disconnect pressure switch wires and inducer motor connector wires.
  4. Remove ten screws from the inducer pan; save screws. **DO NOT** drop screws into heat exchanger openings.
  5. Lift inducer pan (with inducer motor and pressure switch still in place) about 1/4 inch and tilt left side up to clear casing flanges. Use care not to damage inducer gasket.
- NOTE:** If possible, decide on direction of gas entry now. Screws to inlet gas valve fitting are accessible. See Section 11.
6. Rotate inducer pan 180 degrees, line up mounting holes and place inducer pan in furnace. Use care not to damage gasket. Replace ten screws in inducer pan. See Figure 5.

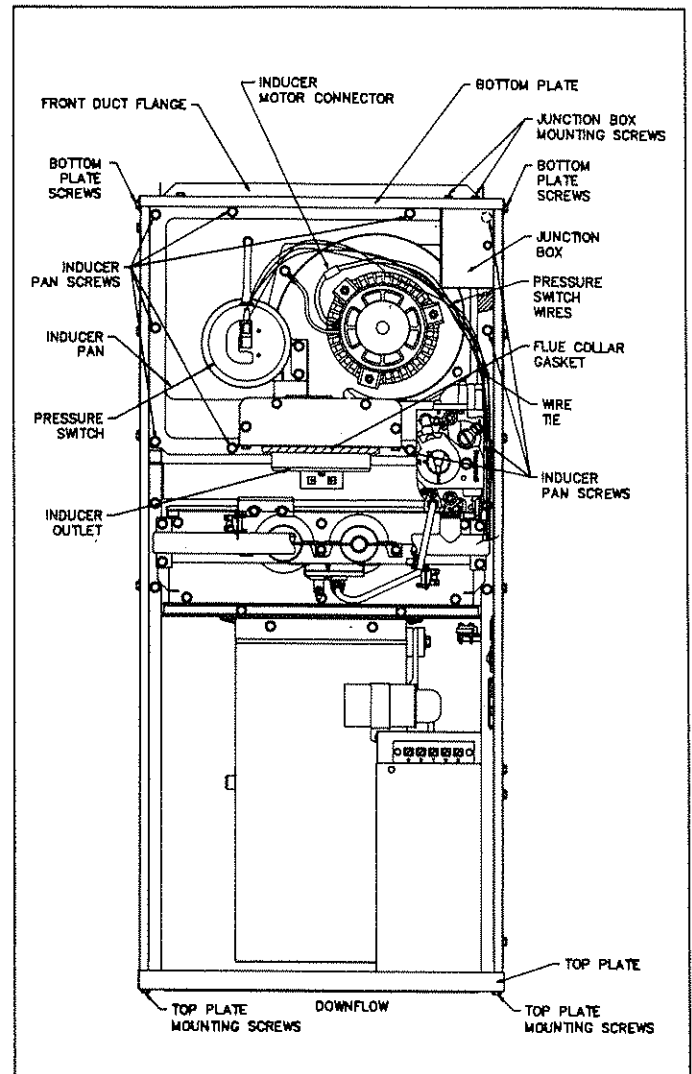

**CONVERTED CONFIGURATION  
FIGURE 5**

7. Pressure switch wires will no longer reach pressure switch. Remove cable tie around excess length of red/yellow piggyback, blue and purple pressure switch wires.
8. Connect pressure switch wires as follows. Wires are numbered on insulation near terminals.
  - a. #1 Purple wire to pressure switch, terminal 'C' (Common).
  - b. #2 Blue wire to pressure switch, terminal 'NC' (Normally Closed).
  - c. #7 and #8 Red/Yellow piggyback wire to pressure switch, terminal 'NO' (Normally Open).
  - d. Route all pressure switch wires over inducer motor.
  - e. Reconnect inducer motor connector.
  - f. Replace wire tie in area that prevents wires from touching hot surfaces.



9. Remove four screws that secure bottom plate to casing sides. Remove bottom plate; save screws.
10. Install top plate, removed in step 2, where bottom plate was. Secure with four screws. Inducer outlet is now lined up with vent outlet in top plate.
11. Stand up furnace with top plate down. Line front duct flange up with holes. Place bottom plate on top of duct flange and secure both to casing with four screws.
12. Install junction box on bottom plate using two #6B screws removed in Step 2. Junction box cover and screw of junction box must face front of furnace.
13. Gasket around flue collar must be in place. If gasket is loose, glue it. If gasket is damaged, replace it.
14. Install a single wall vent pipe section (minimum length 30 inches) (Field-Supplied) to inducer outlet with three equally spaced screws. This pipe serves as an inducer outlet extension to which an appropriate vent can be attached. Due to minor variations in vent pipe, available from different manufacturers in the field, and to assure the tightest seal possible, inducer outlet extension is not supplied with furnace. Additional vent pipe sections or Type B1 adapter may then be added when installing the furnace.

**WARNING:** If inducer outlet extension is shorter than 30 inches and chimney or vent becomes blocked, combustion products may be drawn into furnace. This could cause nausea or asphyxiation, resulting in injury or death.

15. Conversion from as-shipped configuration is now complete.

## SECTION 6 — ALLOWING FOR CLEARANCES.

**WARNING:** Do not install furnace on its back, doing so could cause a fire, resulting in damage, injury or death.

Establishing clearances from combustible material.

Locate clearance label on inside of front door. See Figure 6.

**WARNING:** Furnace installation must meet all minimum clearances from combustible material specified in this manual and all applicable codes. Failure to provide required clearance between furnace and combustible materials could cause a fire, resulting in damage, injury, or death.

**WARNING:** This furnace is A.G.A. design certified for direct installation on wood flooring for upflow and horizontal positions.

- Do not install furnace on carpeting, tile or other combustible material.
- Do not install furnace in a closet in horizontal position.
- Do not install furnace on wood flooring without special base in downflow position.

Doing any of the above could cause a fire resulting in damage, injury, or death.

MINIMUM INCHES CLEARANCE TO COMBUSTIBLE MATERIAL IN ALCOVE OR CLOSET.					
<b>UPFLOW POSITION</b>					
TOP	SIDES	BACK	FRONT	VENT	
1	1*	0	6	6 WHEN USING SINGLE WALL	
1	0	0	2	1 WHEN USING B1	
* FOR CASING WIDTHS 17 INCHES OR LARGER 0 CLEARANCE MAY BE USED. 18 INCH FRONT CLEARANCE REQUIRED FOR ALCOVE. FOR INSTALLATION ON COMBUSTIBLE FLOORING.					
MINIMUM INCHES CLEARANCE TO COMBUSTIBLE MATERIAL IN ALCOVE OR CLOSET.					
<b>DOWNFLOW POSITION</b>					
TOP	SIDES	BACK	FRONT	VENT	
1	1*	0	6	6 WHEN USING SINGLE WALL	
1	0	0	2	1 WHEN USING B1	
* FOR CASING WIDTHS 17 INCHES OR LARGER 0 CLEARANCE MAY BE USED. 18 INCH FRONT CLEARANCE REQUIRED FOR ALCOVE. FOR INSTALLATION ON COMBUSTIBLE FLOORING ONLY WHEN INSTALLED ON SPECIAL BASE PART NO. 40244D0.					
MINIMUM INCHES CLEARANCE TO COMBUSTIBLE MATERIAL IN ALCOVE.					
<b>HORIZONTAL POSITION</b>					
TOP	SIDES*	BACK	FRONT	VENT	
1	2*	0	18	6 WHEN USING SINGLE WALL	
1	2*	0	18	1 WHEN USING B1	
* CLEARANCE SHOWN IS FOR AIR INLET AND AIR OUTLET ENDS. VENT MUST MAINTAIN CLEARANCE LISTED ABOVE. FOR INSTALLATION ON COMBUSTIBLE FLOORING.					
FOR HORIZONTAL POSITION LINE CONTACT IS ONLY PERMISSIBLE BETWEEN LINES FORMED BY INTERSECTIONS OF TOP AND TWO SIDES OF FURNACE JACKET AND BUILDING JOISTS, STUDS OR FRAMING.					
ALL POSITIONS REQUIRE 30 INCHES FRONT CLEARANCE FOR SERVICE.					

**MINIMUM CLEARANCES  
FROM COMBUSTIBLE MATERIALS  
FIGURE 6**

### 1. Upflow Installation.

Upflow position is approved for installation on wood flooring. Typical upflow furnace installations are an alcove, attic, basement, closet, garage, or utility room. See Figure 6 or furnace clearance plate for minimum clearances to combustible materials.

### 2. Horizontal Installation

a. Horizontal position is approved for installation on wood flooring. Typical horizontal furnace installations are an alcove, garage, attic, or crawl space. See Figure 6 or furnace clearance plate for minimum clearances to combustible materials.

### b. Attic Installation.

Line contact is permissible for furnaces installed in horizontal positions. The intersection of furnace top and sides forms a line. This line may be in contact with combustible material. However, maintain a 6" clearance to vent connection unless Type B1 vent is used. See Figure 7.

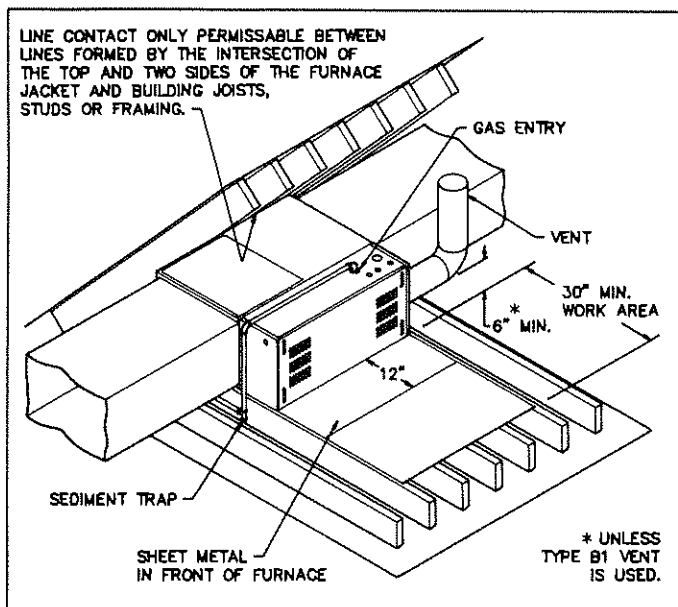

**TYPICAL ATTIC INSTALLATION  
FIGURE 7**

When using single wall vent pipe in horizontal installations, horizontal furnaces with 14.50" high casings must be raised 1" to have 6" clearance to combustible material. See Figure 7.

- c. Install a platform under furnace that extends a minimum 30" in front of furnace. This provides a work area and keeps insulating materials away from combustion air openings. Secure platform to joists.

**WARNING:** When a furnace is installed in an attic or other insulated space, keep all insulating materials at least 12" away from furnace and all burner combustion air openings. Failure to do so could cause nausea, asphyxiation or fire, resulting in damage, injury, or death.

- d. Crawl Space Installation.

Furnace can be hung from floor joists or installed on suitable blocks or pad. Pad or blocks should provide enough height to reduce potential for water damage. See Section 7.

**3. Downflow Installation.**

You must convert furnace from as-shipped configuration for downflow furnace installation. See Section 5.

Downflow position is approved for installation on non-combustible flooring. Typical downflow furnace installations are an alcove, attic, closet, basement, garage, or utility room. See Figure 6 or furnace clearance plate for minimum clearances to combustible materials.

Furnace installation on combustible flooring is permitted with combustible floor base available from manufacturer. Read installation instructions packaged with combustible floor base to correctly install. See Figure 8.

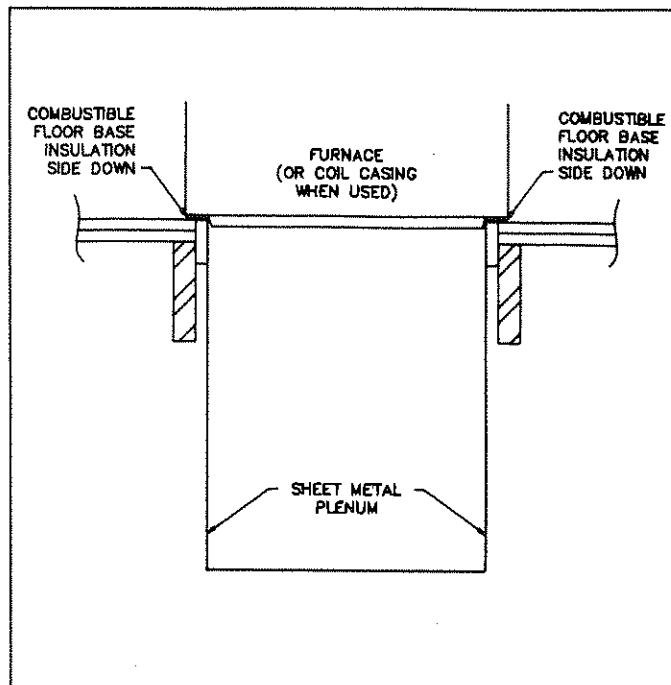

**DOWNFLOW FLOOR OPENING  
FIGURE 8**

See Figure 9 for installation diagram on combustible floor.

**4. Service Clearance.**

Allow minimum front clearance of 30 inches for service. See Figure 6 or inside of front door for minimum service clearance.

**SECTION 7 — SUSPENDING FURNACE.**

Some installations will require that furnace be suspended from rafters or floor joists.

A common way to do this using threaded rods is shown in Figure 10. Consider this means when people may walk underneath furnace. Figure 11 shows another common suspension means using pipe strap. Other means that provide adequate support may be used.

When furnace is not suspended in a crawl space, elevate furnace off ground to avoid water damage and allow for air conditioning coil drain.

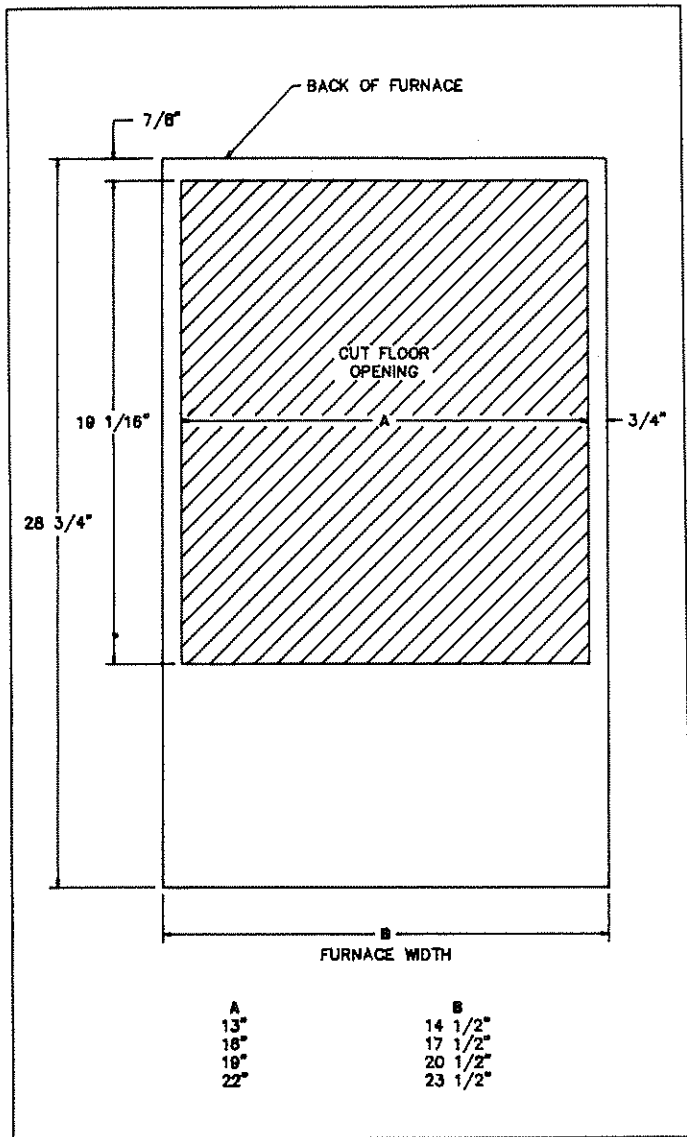

FURNACE, PLENUM, AND BASE INSTALLED ON A COMBUSTIBLE FLOOR  
FIGURE 9

### SECTION 8 — PROVIDING FOR COMBUSTION AND VENTILATION AIR.

Before you begin installing furnace, plan to provide enough combustion and ventilation air following:

- Current National Fuel Gas Code ANSI Z223.1/NFPA 54, Section 5;
- Local Code authorities. Refer to Section 31 of this manual for these codes.

Ventilation is the process of replacing air which is required for furnace operation. The total amount of ventilation air provided within structure must equal all requirements of gas appliances in the building, plus any air quantities removed by range hoods, exhaust fans, etc.

Another reason to supply fresh outdoor air for combustion and ventilation is that it dilutes contaminants found in indoor air. These contaminants include bleaches, adhesives, cleaning solutions, detergents, solvents, cat litter, spray can propellants and most refrigerants.

NOTE: Level furnace from front to back and from left to right within 1/4" per four feet.

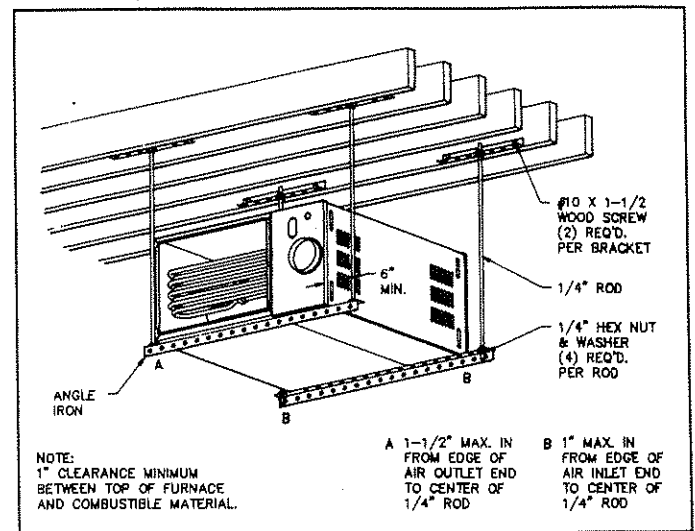

FIGURE 10

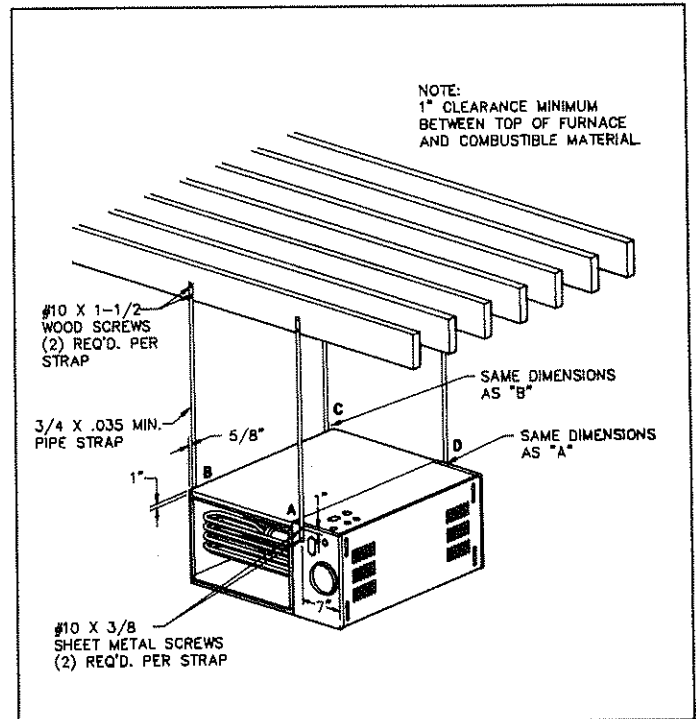

FIGURE 11

**WARNING:** Furnace and any other fuel-burning appliances must have enough fresh air for proper combustion and ventilation. Lack of adequate combustion and ventilation air could cause nausea or asphyxiation, resulting in injury or death.

**WARNING:** During construction, do not use air from inside structure for combustion and ventilation. Vapors from some construction adhesives and materials can become corrosive in the presence of a flame. This could cause failure of heat exchanger or vent system, resulting in damage, injury or death.

**WARNING:** Combustion and ventilation air that contains chlorine, fluorine, bromine and iodine could cause heat exchanger or vent system failure, resulting in damage, injury or death.

**WARNING:** When installing a furnace in an attic or other insulated space, keep furnace free and clear of all insulating materials. Make sure all insulation is at least 12" away from burner combustion air openings and well away from openings into furnace space that supply air for combustion and ventilation. Failure to do this could cause nausea, asphyxiation or fire, resulting in damage, injury or death.

**WARNING:** When installing furnace in an alcove, attic, basement, closet, garage, or utility room do not store items in front of furnace or in front of closet or utility door which would block combustion air openings to furnace. Failure to do this could cause nausea, asphyxiation or fire, resulting in damage, injury or death.

DO NOT install furnace where any combustion or ventilation air openings will allow outside air to blow directly against furnace.

**WARNING:** Drafts blowing directly against furnace could cause improper combustion which could cause heat exchanger failure or fire, resulting in damage, injury or death.

Sufficient air MUST be provided to insure there will not be a negative pressure in furnace room or space. In addition, there MUST be a positive seal between furnace and return air duct to avoid pulling air from burner area.

Provide adequate combustion and ventilation air by considering volume of furnace installation space. Use these instructions and current National Fuel Gas Code ANSI Z223.1/NFPA 54 to determine whether furnace is in an unconfined or confined space.

**A. Determining if your space is confined or unconfined.**

Two factors determine whether a furnace installation space is confined or unconfined:

- Volume of installation space;
- Total gas input of appliances to be installed in that space.

To determine which your space is:

1. First calculate furnace installation space volume in cubic feet.
2. Determine combined input rating (BTUH) of all gas appliances in furnace installation space, including furnace input. This is the total combined input rating.
3. Divide total combined input rating by 1,000. Then divide this number into installation space volume. Here's the formula:

$$\frac{\text{Space Volume}}{\text{Total Input}/1,000} = \text{Ratio}$$

If ratio is less than 50, installation space is a confined space. If ratio is 50 or greater, installation space is an unconfined space.

**B. Installing furnace in confined space.**

**WARNING:** You must provide permanent air openings to a confined furnace installation space from another area as described below. Failure to do so could result in inadequate combustion and ventilation air. These could cause nausea, asphyxiation or fire, resulting in damage, injury or death.

1. Combustion and ventilation air openings.

a. All combustion and ventilation air from inside the structure.

1. The furnace space must be provided with two permanent openings to an additional room(s) of sufficient volume so that the combined volume of all spaces meet the criteria above for an unconfined space.

The total input of all gas appliances within the combined space must be considered in making this determination. See Figure 12.

2. a. Each opening must have minimum free area of one square inch per 1,000 Btu per hour of the total combined input rating of all gas appliances within the confined furnace space, but not less than 100 square inches. One opening must be within 12 inches of the top and another opening within 12 inches of the bottom of the furnace space. See Figure 12.

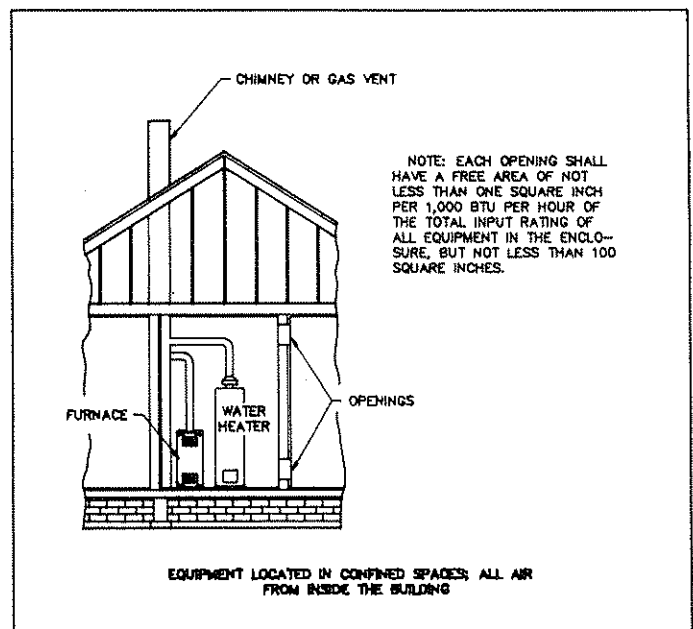

**FIGURE 12**

For example:

Total Input Btuh	Free Area Per Opening (square inches)
40,000-100,000	100
120,000	120
140,000	140

- b. If building is of unusually tight construction, provide a permanent opening directly communicating with the outdoors. Opening shall have a minimum free area of one square inch per 4000 Btuh of total input rating for all equipment in the enclosure.

If return air is taken directly from hallway or space next to furnace that communicates with furnace spaces, all air for combustion must come from outdoors.

- b. All combustion and ventilation air from outdoors.

- The furnace space must be provided with two permanent air openings directly to the outdoors, or by ducts to the outdoors or spaces (attic or crawl spaces) that freely access the outdoors. These combustion and ventilation openings will give fresh air free access to furnace space for combustion and ventilation. You must also provide air sufficient for all other gas appliances within furnace space.

Ducts must freely access outdoors or spaces (attic or crawl spaces) which freely access the outdoors. Well ventilated attics or crawl spaces usually satisfy this requirement.

- Locate one combustion and ventilation air opening within 12" of top of furnace space. Locate another within 12" of bottom of furnace space.
- When directly accessing the outdoors, each opening must have a minimum free area of one square inch per 4,000 Btuh of total combined input rating of all gas appliances within furnace space. See Figure 13A.
- If combustion air ducts will run vertically, ducts and each opening must have a minimum free area of one square inch per 4,000 Btuh total combined input rating. You must allow for all gas appliances within the furnace space. See Figure 13B.

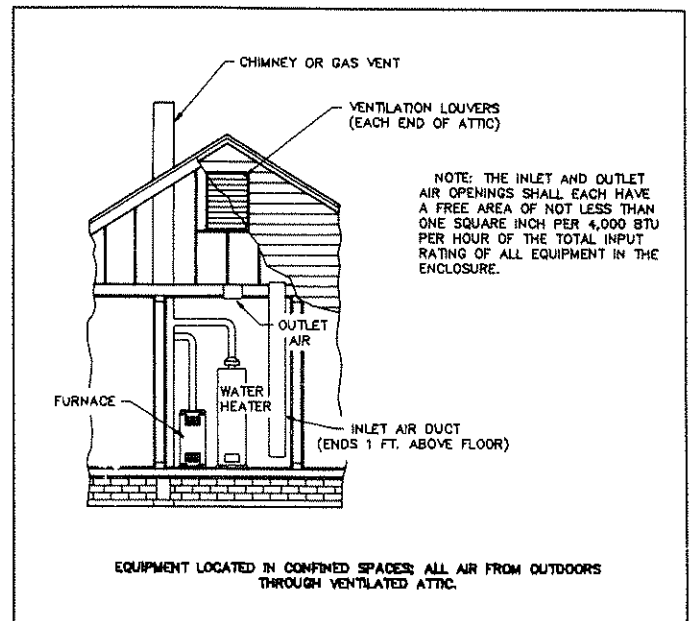

FIGURE 13A

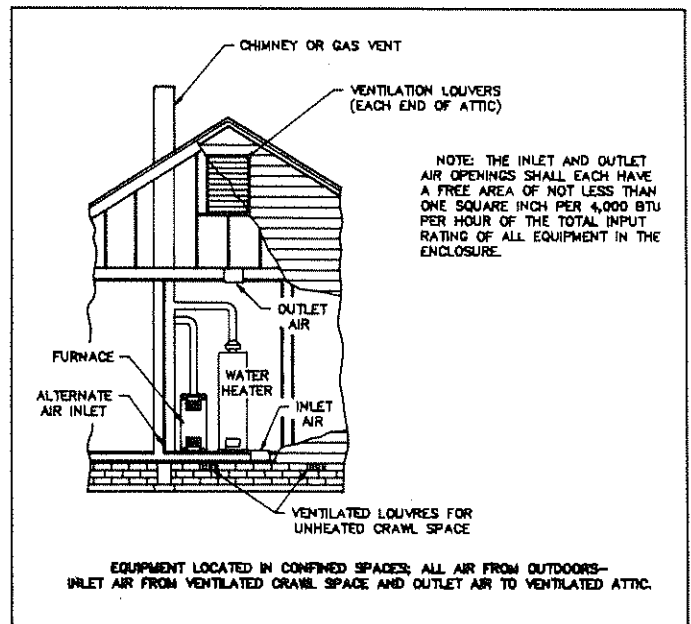

FIGURE 13B

For example:

Total Input Btuh	Required Free Area per Opening (square inches)	Suggested Round Pipe (Inches dia.)
40,000	10.0	4
60,000	15.0	5
80,000	20.0	6
100,000	25.0	6
120,000	30.0	7
140,000	35.0	7

5. If combustion air ducts will run horizontally, ducts and each opening must have a minimum free area of one square inch per 2,000 Btuh total combined input rating. You must allow for all gas appliances within the furnace space. See Figure 14.

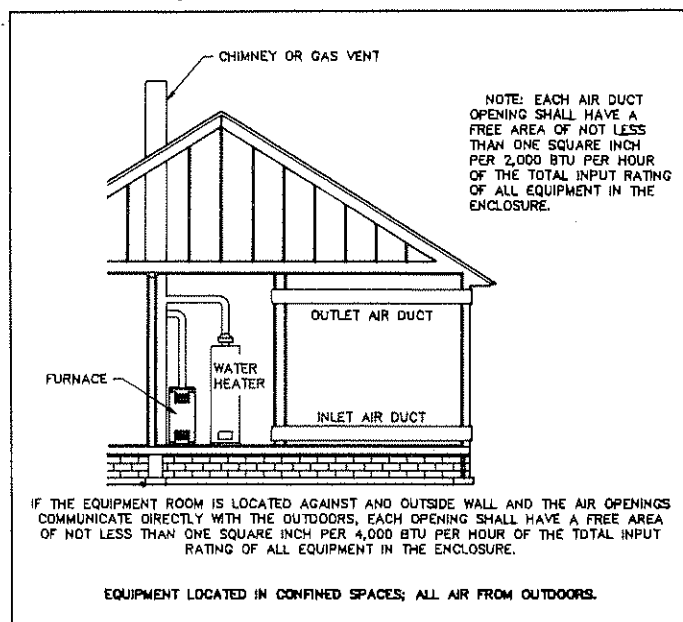

FIGURE 14

For example:

Total Input Btuh	Free Area per Opening (square inches)	Round Pipe (inches dia.)
40,000	20	6
60,000	30	7
80,000	40	8
100,000	50	8
120,000	60	9
140,000	70	10

6. Ducts which introduce combustion and ventilation air from outside structure into furnace space, must have the same cross sectional area as the free area of openings to which they connect. The minimum dimension of rectangular air ducts shall not be less than 3 inches.

2. Louvers, grilles, and screens.

Sometimes, louvers, grilles, or screens cover combustion and ventilation air openings. If so, you must provide larger openings than those calculated above. This is necessary because louvers, grilles and screens block and reduce an opening's free area.

Louver, grille and screen manufacturers supply technical data on their products, which usually includes the "free area." Sizing the openings with louvers, grille or screen in place will provide minimum free area to furnace space as calculated above. Do not use screen smaller than 1/4" mesh. If you do not know free area, assume that wood louvers have 20

to 25% free area. Assume metal louvers and grilles have 60 to 75% free area. Refer to current National Fuel Gas Code ANSI Z223.1/NFPA 54.

Example: Furnace is 100,000 Btuh input and is to be installed in a confined space that contains no other gas appliances. Rectangular combustion and ventilation air ducts will run horizontally from outdoors to furnace space.

- a. Calculate free area required.

Because combustion and ventilation air ducts run horizontally, allow 2,000 Btuh. See 2b. above.

$$\begin{array}{r} \text{Furnace Input} \\ \text{Btuh} \\ \hline 2,000 \text{ Btuh} \\ \text{per square inch} \\ \\ 100,000 \\ \hline 2,000 \end{array} \begin{array}{l} = \text{Free Area Required} \\ \\ \\ = 50 \text{ square inches} \end{array}$$

Each opening must have a free area of 50 square inches.

- b. Calculate overall area of openings to give needed free area once you cover them to keep out rain and other outside elements.

Example: If you will use wood louvers to cover combustion and ventilation air openings and you do not know free area of wood louvers, use 20%, as suggested in ANSI Z223.1/NFPA 54.

$$\begin{array}{r} 100 \times \text{Free area} \\ \text{from a) above)} \\ \hline \text{Louver free area} \\ \text{openings expressed} \\ \text{as a percentage} \end{array} \begin{array}{l} = \text{overall area of} \\ \text{openings with wood} \\ \text{louvers installed} \end{array}$$

$$\frac{100 \times 50}{20} = 250 \text{ square inches}$$

Each of the two combustion and ventilation air openings must have a total area of 250 square inches. This is when wood louvers cover openings for a 100,000 Btuh input furnace and combustion and ventilation air ducts run horizontally.

- c. Calculate minimum rectangular duct size needed.

If you choose a rectangular duct with the minimum allowed dimension of 3", the other duct dimension must be at least 16-2/3". This is calculated by dividing the 50 square inches of free area from a) by 3", with equals 16-2/3".

**WARNING:** You must fix combustion and ventilation air louvers and grilles in open position or interlock them with furnace operation. Furnace operation

with louvers or grilles closed could cause inadequate combustion or ventilation air, resulting in injury or death.

### C. Installing furnace in unconfined space.

Refer to current National Fuel Gas Code ANSI Z223.1/NFPA 54 for more information. This code does not require that you make special provisions for combustion and ventilation when furnace is in an unconfined space. However, it is always prudent to arrange for combustion and ventilation air as if installation space is confined space.

In the past, infiltration through loose construction provided enough air for combustion and ventilation when furnace was in an unconfined space. Current construction methods may now prevent infiltration of air into unconfined space. These current methods include increased insulation, vapor barriers, tight fitting doors and windows, and weather-stripping.

### D. Allowing for exhaust fan operation.

1. When furnace is in a ventilated attic, crawl space, residence garage, or outside the heated space, exhaust fan drafts can adversely affect its operation. These drafts can come from kitchens, bathrooms, clothes dryers or anywhere within the heated space.

**WARNING:** Exhaust fans that blow against furnace could cause heat exchanger failure or fire, resulting in damage, injury, or death.

2. When furnace is in a repair garage or inside the heated space, exhaust fans can adversely affect its operation. Exhaust fans in kitchens, bathrooms, clothes dryers or anywhere within heated space increase combustion and ventilation air requirements. This is because exhaust fans reduce the amount of combustion and ventilation air available to the furnace. A fireplace also reduces amount of combustion and ventilation air. You must allow for these reductions.

**WARNING:** You must allow for reduction of air available for combustion and ventilation by exhaust fans and fireplaces. Failure to do so could result in inadequate combustion and ventilation air. This could cause nausea, asphyxiation, or fire, resulting in damage, injury, or death.

3. Exhaust fan air may contain compounds of chlorine, fluorine, bromine, and iodine. If used for combustion, this contaminated air will adversely affect furnace operation.

**WARNING:** If used for combustion and ventilation, contaminated exhaust fan air could cause heat exchanger or vent system failure resulting in damage, injury, or death.

## SECTION 9 — PROVIDING FOR PROPER VENTING.

Vent furnace using these instructions and Venting Addendum. Also, meet requirements of local utilities and other local code authorities. You must connect furnace to a vent or factory-built chimney or a suitably sized, constructed and lined masonry chimney. Vent or factory-built chimney must meet a recognized standard. Chimney lining method and material must comply with local requirements. Use corrosion-resistant material meeting nationally recognized standards for vent construction.

**WARNING:** Inadequate vent or chimney could allow combustion products to collect in structure, resulting in injury or death.

**WARNING:** Vent this furnace separately from any appliance designed to burn solid fuel, particularly wood-burning or coal burning appliances. Improper venting could allow combustion products to collect in structure, resulting in injury or death.

### A. Venting category.

The furnaces covered by this manual are design-certified as CATEGORY 1 for venting. CATEGORY 1 furnaces have non-positive vent static pressure and rely on the heat content of combustion products to vent. You may common vent CATEGORY 1 furnaces.

The furnaces covered in this manual are also design-certified as CATEGORY 3 for venting, only when they are installed with manufacturer specified vent system components and installation practices.

Category 3 gas appliances rely on the heat content of combustion products and mechanical or other means to vent. You may not common vent CATEGORY 3 gas appliances.

### B. Types of vent systems.

These definitions will help you understand the terms we use.

1. "Vent" and "chimney" refer to open passageways. These passageways convey vent gases from vent connectors to the outside. Gases begin their final ascent at the vent or chimney. Vents and chimneys usually run vertically or nearly vertical. When they serve only one gas appliance, they are called "dedicated" vents or chimneys. When they serve multiple gas appliances, they are called "common" vents or chimneys.
2. A "vent connector" connects a gas appliance to a vent or chimney. Vent connectors usually run directly from the furnace draft inducer collar to vent or chimney. Vent connectors may have vertical and horizontal runs.
3. A "venting system" is a continuous open passageway from the draft inducer collar to the outside. Venting systems usually have vent connector(s) and a vent or chimney. Venting systems commonly serve a single furnace or a single furnace and a water heater. Other multiple-appliance venting systems are less common.

## C. Design considerations.

### 1. General considerations.

Avoid oversizing furnace for your application. Select a furnace model with a rated heating output close to the calculated heating load. This extends the firing period, decreasing the potential for condensate formation in the vent.

- a. Too small a vent cannot carry all combustion products outdoors. Too large a vent will not vent combustion products rapidly enough to avoid potential for condensation. Refer to Venting Addendum for correct size vent.
- b. Vent height must be a minimum of five feet. Minimize vent connector horizontal runs to the extent possible for best performance.
- c. The designer must consider the building's orientation, answering these questions. Will the vent terminate outside the building where its operation could be adversely affected by winds? Could any adjacent buildings adversely affect vent operation? Allowing for these factors can reduce the possibility of downdraft conditions.
- d. If your local experience indicates possible condensation problems, provide for draining and disposal of venting system condensate.

### 2. Vent sizing.

- a. Sometimes the horizontal distance from the furnace to the vent or chimney is already given; this is known as the horizontal vent connector run. The vent or chimney height is also usually given as is the Btuh input of the gas appliances served by the vent.

Check these parameters to be sure the venting system will work. Use approved engineering practices, Venting Addendum, these instructions, and Part 7 of current National Fuel Gas Code ANSI Z223.1/NFPA 54. Use vent capacity tables in Venting Addendum to check existing or new vent sizes for CATEGORY 1 furnaces.

- b. See Venting Addendum for single appliance venting and multiple appliance (common) venting. For multi-story installations, refer to current National Fuel Gas Code ANSI Z223.1/NFPA 54.
- c. Minimum vent connector diameter from furnace to vent or chimney is same as draft inducer collar.

### 3. Vent connector.

- a. Vent connectors must be made of noncombustible, corrosion resistant material capable of withstanding vent gas temperatures. They must be thick enough to withstand physical damage and be accessible for inspection, cleaning and replacement.

- b. Use Type B1 vent connectors in or through attics, crawl spaces, or other cold areas. Install thimbles that meet local codes when vent connectors pass through walls or partitions of combustible material.

- c. Keep vent connectors as short as possible by locating furnace as close as practical to vent or chimney. Avoid unnecessary turns or bends which create resistance to flow of vent gases.

Adding an elbow adds resistance. For example, adding a 6" 90-degree elbow would be the equivalent of adding 20 feet of horizontal 6" pipe. 45-degree elbows have lower resistance than 90-degree elbows, and can work for most vent runs.

- d. You may increase vent connector diameter to overcome installation limitations and obtain connector capacity equal to furnace input. Make this increase as close as possible to draft inducer collar, allowing for necessary adapters and fittings.

- e. If you join two or more vent connectors before they enter the vertical vent or chimney, use caution. See Venting Addendum.

- f. Do not connect this furnace to any portion of a vent system which operates under positive pressure. Positive pressure would result with CATEGORY 3 and 4 appliances connected to the vent.

- g. Do not connect vent connector to a chimney flue serving a fireplace unless you permanently seal fireplace flue opening.

### 4. Vertical vent or chimney.

- a. Vents and chimneys usually extend vertically with offsets not exceeding 45-degrees. Consider vent pipe runs more than 45-degrees as horizontal runs. Include their length in the total horizontal run.

- b. Designer and installer must provide an appropriately sized common vent for all appliances connected to it. See Venting Addendum.

- c. Connect this CATEGORY 1 furnace only to vent systems with other CATEGORY 1 appliances.

**WARNING: Do not connect this Category 1 furnace to a vent system used by Category 3 and 4 appliances. Do not connect it to vents with mechanical draft systems operating at positive pressure. Improper venting could allow combustion products to collect in structure during use, resulting in damage, injury or death.**

### 5. Chimney.

Furnace is suitable for venting into a properly sized and lined masonry chimney. Consult National Fuel Gas Code ANSI Z223.1/NFPA 54 for construction details. If chimney is oversized, liner is inadequate



or evidence of condensate exists, consider using chimney as a pathway for suitably sized Type B1 vent liner. See Figure 15.

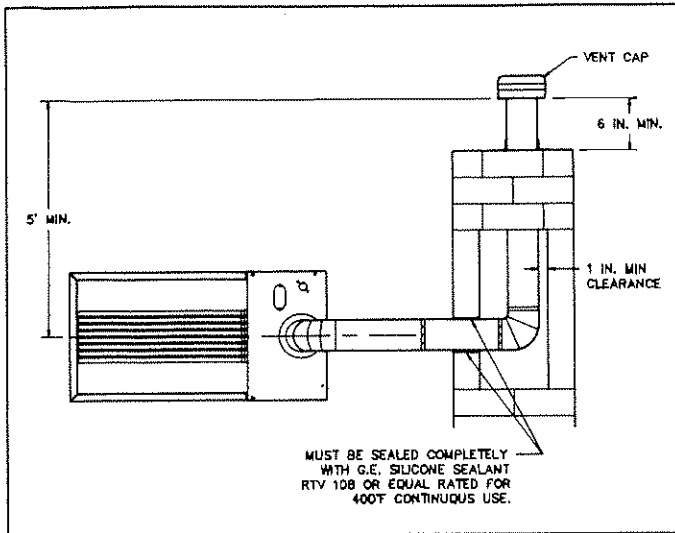

FIGURE 15

**WARNING:** Support Type B1 vent liner in masonry chimney. Maintain at least a 1" clearance on all sides to reduce possibility of condensate in vent. Condensate may cause vent to deteriorate allowing combustion products to collect in structure, which could result in injury or death. See Figure 16.

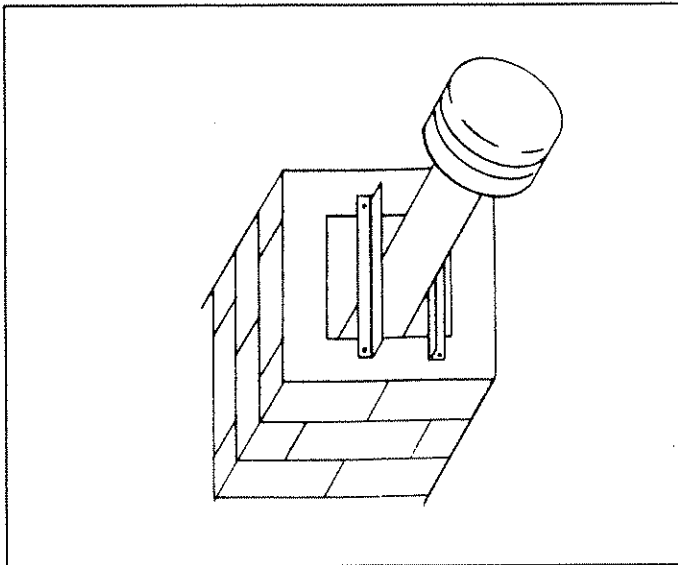

FIGURE 16

**WARNING:** Vent liner must not block opening where other appliances' vent connectors enter chimney. Blocked openings could cause combustion products to collect in structure, resulting in damage, injury or death.

**WARNING:** Do not use unlined masonry chimneys. These increase risk of condensate formation, which may cause chimney to deteriorate, allowing combustion products to collect in structure, resulting in damage, injury or death.

**NOTE:** For more information on proper chimney inspection and relining procedures, Gas Research Institute (GRI) has a topical report entitled "Masonry Chimney Inspection and Relining". Obtain copies through American Gas Association (A.G.A.) at 1-800-841-8400.

6. Vent termination.

- a. Terminate all vertical vents with a listed vent cap or roof assembly unless local codes require otherwise. See vent cap or roof assembly manufacturer's instructions. Locate vent termination (vent cap or roof assembly) in an area without positive wind pressures or eddy currents. Eddy currents occur when air swirls over roof peaks. They can cause down-drafts and adversely affect vent operation. See Figure 17.

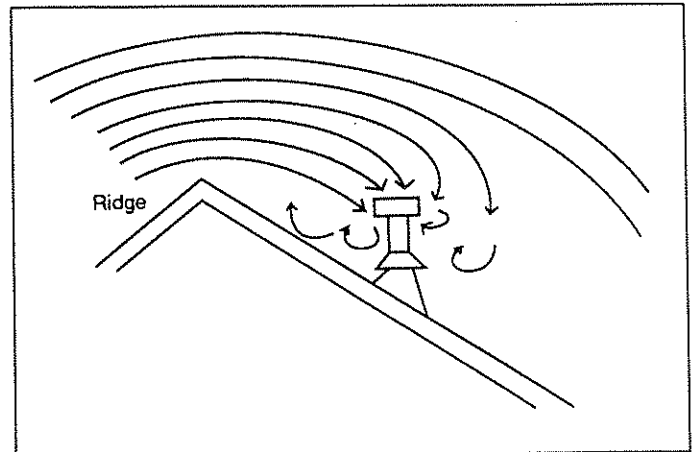
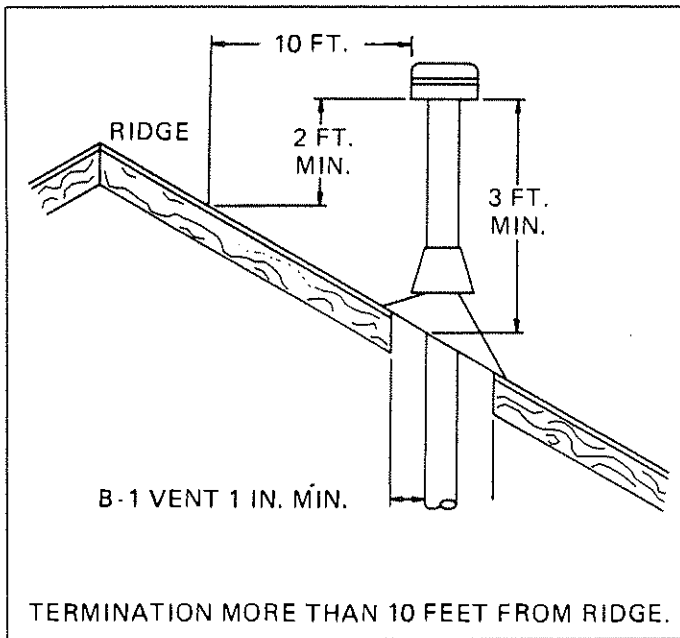

FIGURE 17

Some vent terminations or caps protect against eddy currents and down-drafts. Consult their manufacturer's instructions. Vent terminations or caps should usually be at least the same size as the vent. They may be larger if the installation warrants.

- b. Vent systems must end at least five feet above the highest gas appliance connection. Vent pipe must extend at least three feet above the point where it passes through the roof. Vent termination must be at least two feet higher than any portion of building within ten feet horizontal and vent termination must be at least two feet higher than roof peaks within ten feet horizontal. See Figures 18 and 19. Some vent cap manufacturers offer vent caps that allow reduced clearances. Consult their instructions.



**TERMINATION MORE THAN 10 FEET FROM RIDGE  
FIGURE 18**

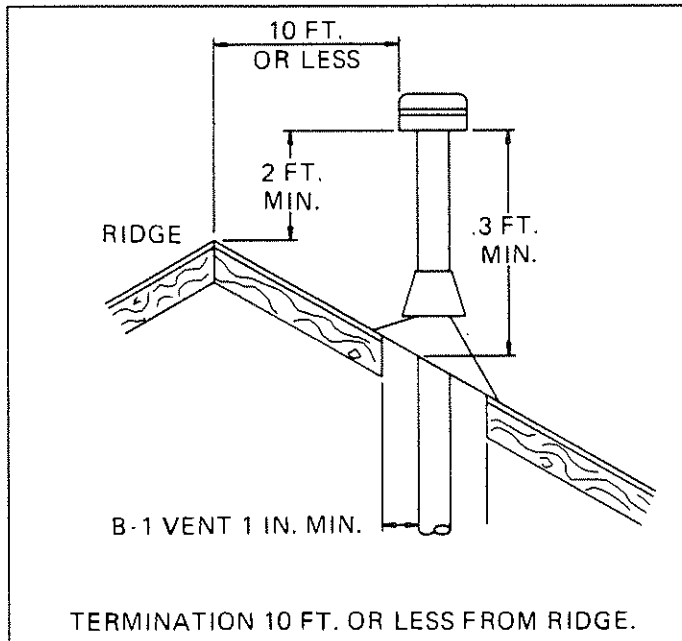

**TERMINATION 10 FEET OR LESS FROM RIDGE  
FIGURE 19**

**WARNING:** Failure to properly terminate vent chimney systems could allow combustion products to collect in structures, resulting in injury or death.

- c. Terminate venting system at least three feet above any forced-air building inlet within ten feet. Consider doors, windows and gravity air building inlets. Locate vent termination at least four feet below, four horizontal feet from or one foot above any of these openings.

## D. Installation.

### 1. Vent connectors.

Attach vent connector at draft inducer collar. Make sure flue gasket is in place providing a seal. Use a minimum of three equally spaced screws around connection. Connect all other vent pipes using three equally spaced screws at each joint. Exception is only when you use Type B1 vent pipe with self-locking connections or high temperature plastic pipe.

**WARNING:** Unsecured vent pipe connections may loosen. This can allow combustion products to collect in structure, resulting in injury or death.

Install vent connectors without any dips or sags. Slope them upward from furnace at least 1/4" per foot. To prevent sagging, at each joint support vent connectors and horizontal portions using hinges, straps or equivalent. Seal all connections where vent connectors enter chimney. See Figure 15.

To avoid blockage, attach vent connector to a masonry chimney above the extreme bottom. For inspection ease, use thimble or slip joint to make vent connector removal easy. Firmly attach connector. Insert all vent connectors into, but not beyond, inside chimney wall.

### 2. Vertical vent or chimney systems.

Install vent materials following their listing terms, manufacturer's instructions, these instructions and local codes.

A gas vent passing through a roof must extend through roof flashing, jack or thimble. It must terminate above roof surface.

## E. Existing vent considerations.

Masonry chimneys previously used for venting solid fuel or oil burning equipment should be lined with suitable metal liner. Also provide an accessible clean out per current National Fuel Gas Code ANSI Z223.1/NFPA 54.1.

### 1. Inspection of vents (chimneys).

- a. Make sure existing vent or chimney is proper size and construction for appliances that will use it. The best way to do this is to size as if it were a new installation. Compare the existing vent to your calculations and make necessary corrections.
- b. Examine vent or chimney cleanouts to make sure they remain tightly closed when not in use. Make sure vent or chimney passageway is clear and free of obstructions. Look for evidence of condensate or deterioration in vent or chimney. Either of these means an inadequate vent.
- c. If you find an inadequate vent or chimney, do not leave it as is. Repair or replace it. A new vent must meet these instructions and current

National Fuel Gas Code ANSI Z223.1/NFPA 54.  
Rebuild a chimney to meet national standards.

**WARNING:** An inadequate vent or chimney could allow combustion products to collect in structure, resulting in injury or death.

- d. Sometimes you will replace a common vented appliance. Make sure common vent size is correct for all appliances connected to it. If you remove a furnace from a common vent without replacing it, the vent will likely be too large for remaining appliances. See Venting Addendum.
- e. The following steps shall be followed with each appliance remaining connected to common venting system placed in operation, while other appliances remaining connected to common venting system are not in operation.
  1. Seal any unused openings in common venting system.
  2. Visually inspect venting system for proper size and horizontal pitch and determine there is no blockage or restriction, leakage, corrosion and other deficiencies which could cause an unsafe condition.
  3. Insofar as is practical, close all building doors and windows and all doors between space in which appliances remaining connected to common venting systems are located and other spaces of building. Turn on clothes dryers and any appliances not connected to common venting system. Turn on any exhaust fans, such as range hoods and bathroom exhausts so they will operate at maximum speed. Do not operate a summer exhaust fan. Close fireplace dampers.
  4. Follow Operating Instructions. Place appliance being inspected in operation. Adjust thermostat so appliance will operate continuously.
  5. After it has been determined that each appliance remaining connected to common venting system properly vents when tested as outlined above, return doors, windows, exhaust fans, fireplace dampers and any other gas-burning appliance to their previous conditions of use.
  6. If improper venting is observed during any of the above tests, common venting systems must be corrected.

**NOTE:** Follow current National Fuel Gas Code ANSI Z223.1/NFPA 54 to correct improper common vent operation. Any common vent resizing must approach minimum size determined by using Venting Addendum.

## SECTION 10 — TOOLS NEEDED FOR INSTALLATION.

ITEM	TOOL DESCRIPTION	USED FOR
<b>A. HAND TOOLS</b>		
1.	Carton Knife	Furnace removal from carton
2.	1/4" nut driver	Control box cover
3.	5/16" nut driver	Casing and blower
4.	3/8" nut driver	Blower and motor mounts
5.	1/4" x 8" straight-blade screwdriver	Wire terminals and manifold pressure adjustment
6.	#2 x 8" Phillips screwdriver	Components in control box
7.	7/16" open end or tubing wrench	Main burner orifices
8.	2-6" to 14" pipe wrenches	Gas pipe installation
9.	4" adjustable wrench	Blower wheel set screw tightening
10.	8" Channel-lock pliers	Strain reliefs
11.	3/16" Allen wrench	Inlet and outlet pressure tap plug removal from gas control
12.	9/64" Allen wrench	Honeywell gas inlet fitting
<b>B. SUPPLIES</b>		
13.	Pipe thread sealant suitable for use with propane (L.P) gas	Gas pipe and controls
14.	Bottle of soap solution	Gas leak checking
15.	2-1/8" pipe, manual shutoff valves	Gas control inlet and pressure checking
<b>C. TEST INSTRUMENTS</b>		
16.	Volt meter with 50 and 150 volt ranges	Electrical check of controls and power supply
17.	Clamp around ammeter with 10 amp and higher ranges	Amp draw of motors and control check

18.	10-turn coil of wire to fit on ammeter	Room thermostat heat anticipator setting
19.	"U" Tube Water Manometer with 0.1" resolution 0" to 15" W.C. range	Gas pressure measurement
20.	Slope gauge with 0.01" pressure measurement taps and tubing, 0 to 1" W.C. range	Duct work static pressure
21.	2 thermometers with 1-degree Fahrenheit resolution, 50 degrees F to 175 degrees F range	Temperature rise measured through furnace
22.	Stop watch	Gas input meter timing
23.	Torque wrench (100 inch-pounds)	Proper screw installation

## SECTION 11 — INSTALLING GAS PIPING.

Equipment needed: Save time by getting these tools before you start: Item number(s) 8,12,13 and 14 listed in Section 10.

### A. Preparation.

Gas piping must meet requirements of current National Fuel Gas Code ANSI Z223.1/NFPA 54 and local codes. Size of pipe running to furnace depends on:

- Length of pipe;
- Number of fittings;
- Specific gravity of gas;
- Input requirements (Btuh) of all gas-fired appliances attached to same main supply line.

Refer to current National Fuel Gas Code ANSI Z223.1/NFPA 54 for correct gas pipe sizing information.

Plan furnace gas supply piping so it will not interfere with removal of burner assembly, front door or blower door for servicing.

Always use a pipe thread sealant which is resistant to propane (LP) gas solvent action. Sparingly apply sealant to all joints on male threads only, starting two threads back from end.

### B. Installation.

1. Install A.G.A. listed manual shut-off valve in gas supply line immediately upstream of furnace. Install 1/8" NPT plugged tapping accessible for test gauge connection. Omit separate, plugged tapping if local area accepts plugged tapping in gas control inlet.
2. After in-line manual shut-off valve, install a drip leg (sediment trap) at gas supply line inlet connection to

furnace. A convenient way to do this when you have reduced bottom clearance, is to make drip leg by using a 1/2" to 1" NPT Tee. Then install a 1-1/2" long, 1" NPT nipple in Tee with a 1" NPT pipe cap to complete drip leg.

3. When using black iron gas pipe, install an A.G.A. listed ground joint union between drip leg (sediment trap) and furnace gas control. Locate ground joint union to allow easy servicing of burner assembly and gas control.

4. Install gas pipe to inlet side of furnace gas control.

**WARNING:** Do not thread gas pipe too far. Doing so may cause gas control to spill or crack which could cause a gas leak or distortion or malfunction of gas control. These could cause a fire or explosion resulting in damage, injury or death.

5. Isolate gas control from gas supply line pressure during leak check. Gas supply line test pressure determines how you isolate gas control.

**WARNING:** At gas supply line, test pressure equal to or less than 14 inches W.C. (1/2 PSI). Isolate gas control from gas supply line by turning furnace gas control knob clockwise to off position. Unexpected surges could damage gas control causing gas to leak, resulting in fire or explosion.

**WARNING:** When test pressure is above 14 inches W.C. (1/2 PSI), completely disconnect gas control from gas supply line. Failure to isolate gas control from test pressure could damage it, causing gas to leak, resulting in fire or explosion.

6. Use a commercial soap solution made to detect leaks and check all gas piping connections. Bubbles indicate gas leakage. Seal all leaks before proceeding.

**WARNING:** Never use an open flame to check for gas leaks. If a leak does exist, a fire or explosion could occur, resulting in damage, injury or death.

### C. Furnace Gas Entry Piping.

1. See below for gas entry holes and knockouts.
  - a. A 1-1/4" x 2-3/4" knockout in top plate.
  - b. A 1-1/2" diameter hole and a 1-1/4" x 1-15/16" knockout in right side of casing.
  - c. Two 1-5/8" diameter knockouts in left side of casing.
2. Changing Gas Control Inlet.

You may want to change direction of gas inlet elbow on gas control. Gas control is shipped for right side gas entry. If you need top entry, remove the fitting. If you need left side gas entry, rotate the fitting 180 degrees.

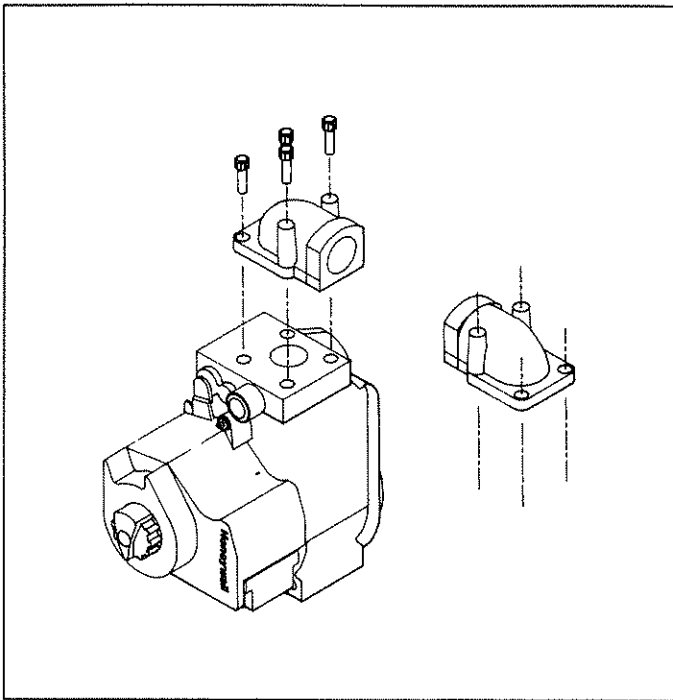

**FIGURE 20**

- a. Use 9/64" Hex Allen wrench to remove four screws. Check that O-ring is in bottom of gas inlet elbow. Rotate elbow to desired position.
- b. Alternately tighten four screws to 45 inch pounds to form a gas tight seal.
- c. Use a commercial soap solution made to detect leaks and check all gas piping connections. Bubbles indicate gas leakage. Seal all leaks before proceeding.

**WARNING:** Never use an open flame to check for gas leaks. If a leak does exist, a fire or explosion could occur, resulting in damage, injury or death.

3. Allowing for Electronic Air Cleaners.

Some large electronic air cleaners will interfere with incoming gas line. Install air cleaner on opposite furnace side from gas entry or route gas pipe over top of air cleaner through one of alternate knockouts.

**SECTION 12 —  
INSTALLING ELECTRICAL WIRING.**

Equipment Needed: Save time by getting these tools before you start: Item number(s) 2 listed in Section 10.

Select a location for room thermostat that is away from supply and return air registers, on draft-free interior wall, and not near lights, television, direct sunlight, or other heat sources. Install thermostat following field wiring diagram in Section 13. Use electrical wiring that meets current National Electrical Code ANSI/NFPA 70 and local codes. Use Type T (63 degrees C rise) wire or equivalent. See Section 30 for code information.

**WARNING:** Provide furnace with its own separate electrical circuit, means of circuit protection and electrical disconnect switch. Follow current National Electrical Code ANSI/NFPA 70 and state and local codes. Failure to provide these shut-off means could cause electrical shock or fire, resulting in damage, injury or death.

Install proper electrical grounding by attaching grounding source to green wire conductor in furnace junction box. Follow current National Electrical Code ANSI/NFPA 70 and local codes.

**WARNING:** Furnace must have proper electrical ground. Failure to provide a proper electrical ground could cause electrical shock or fire, resulting in damage, injury or death.

**SECTION 13 —  
FOLLOWING FIELD WIRING DIAGRAM**

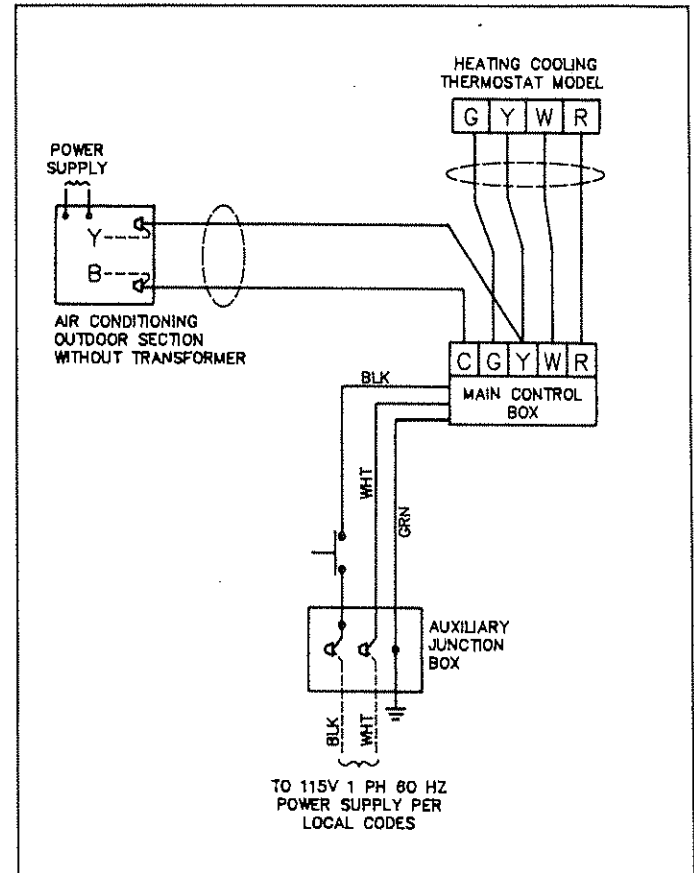

**FIELD WIRING DIAGRAM  
FIGURE 21**

**NOTE:** When replacing original wire, use same type, color, or equivalent wire. Remember to renumber wire ends.

**SECTION 14 — ADJUSTING ROOM  
THERMOSTAT HEAT ANTICIPATOR**

Equipment Needed: Save time by getting these tools before you start: Item number(s) 5, 17 and 18 listed in Section 10.

Wire system using field wiring diagram in Section 13.

### A. Exact heat anticipator setting.

Exactly setting heat anticipator helps avoid potential call-backs. If you have any of the following factors, set heat anticipator to match actual current draw in circuit.

- The system contains controls other than those specified on wiring diagram;
- The system contains nonstandard (18 AWG) size thermostat wire;
- The system has longer than a 30-foot distance between thermostat and furnace.

Follow these steps to exactly set heat anticipator:

1. Use 2-foot piece of 24-gauge thermostat wire, stripped on both ends.
2. Use ammeter capable of reading exact amperage in 0-10 amp range. If it is adjustable, set on 0-10 scale.
3. Wind the 2-foot piece of 24-gauge thermostat wire ten times around one open arm of ammeter. Close ammeter arms. This will act as a ten times multiplier.
4. Make sure 115-volt power to furnace is on. Connect ends of wire on ammeter across terminals "R" and "W" of thermostat sub-base. Follow Figure 22.

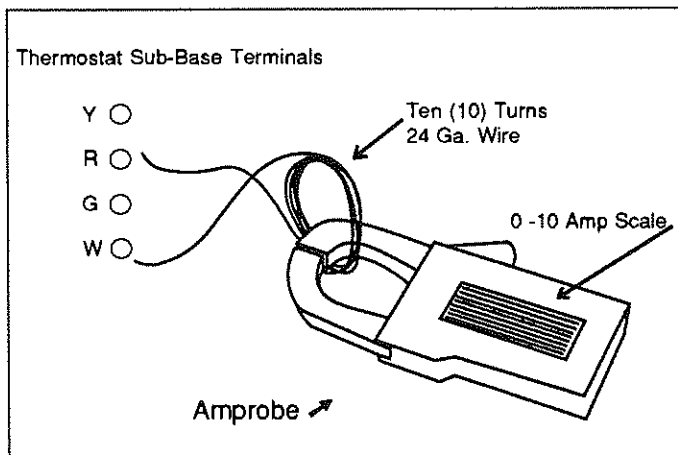

FIGURE 22

5. Read amp draw of furnace circuit on ammeter and divide by 10. This gives you an exact heat anticipator setting.

Example:

Meter reading	=	<u>9 amps</u>
Divide by 10 turns	=	10
Heat anticipator setting	=	.9 amps

6. Set room thermostat's heat anticipator to this amp setting. Follow instructions provided with thermostat.

### B. Approximate heat anticipator setting.

Find heat anticipator under room thermostat cover. Set heat anticipator at 0.6 amps. Follow instructions provided with thermostat.

## SECTION 15 — SEQUENCE OF OPERATION.

See Figure 23 for furnace wiring diagram.

Thermostat calls for heat, energizing electronic ignition lock-out module. Electronic ignition lockout module provides power to gas control and igniter to light pilot. After proving pilot flame, inducer relay (IDR) closes, energizing inducer motor. Inducer motor starts and pressure switch closes, energizing gas control and time delay relay (TDR). Time delay relay energizes main blower within 20 to 30 seconds.

**NOTE:** If system locks out, set room thermostat below room temperature for at least 10 seconds, then return to desired setting. To purge gas lines, it may be necessary to operate furnace through more than one lockout cycle at start-up.

After room thermostat is satisfied, gas control and inducer relay are de-energized simultaneously. Inducer motor de-energizes and returns pressure switch to normally closed (N.C.) position. Main blower remains energized through time delay relay for up to 180 seconds.

## SECTION 16 — INSTALLING DUCT WORK.

**CAUTION:** Install all duct work to meet current standards:

- ASHRAE/NFPA 90, Standard for Installation of Warm Air Heating and Air Systems;
- State and local codes.

Failure to follow these standards could reduce air flow or increase air leakage, resulting in reduced system performance or furnace damage.

Properly size duct work based on heat loss and heat gain calculations. Doing so assures:

- Good heating and cooling installations;
- Potentially fewer callbacks;
- Delivery of required circulating air.

For all furnaces, design duct systems for minimum and maximum external static pressures detailed in Figure 24. See Section 25 on measuring duct work static pressure.

**NOTE:** When furnace is installed in an upflow position, air delivery above 1800 CFM requires both sides of furnace be used for return air, or a combination of one side and bottom or bottom only.

Downflow installations use top return or top and side return. Horizontal installations use end return or end and top return.

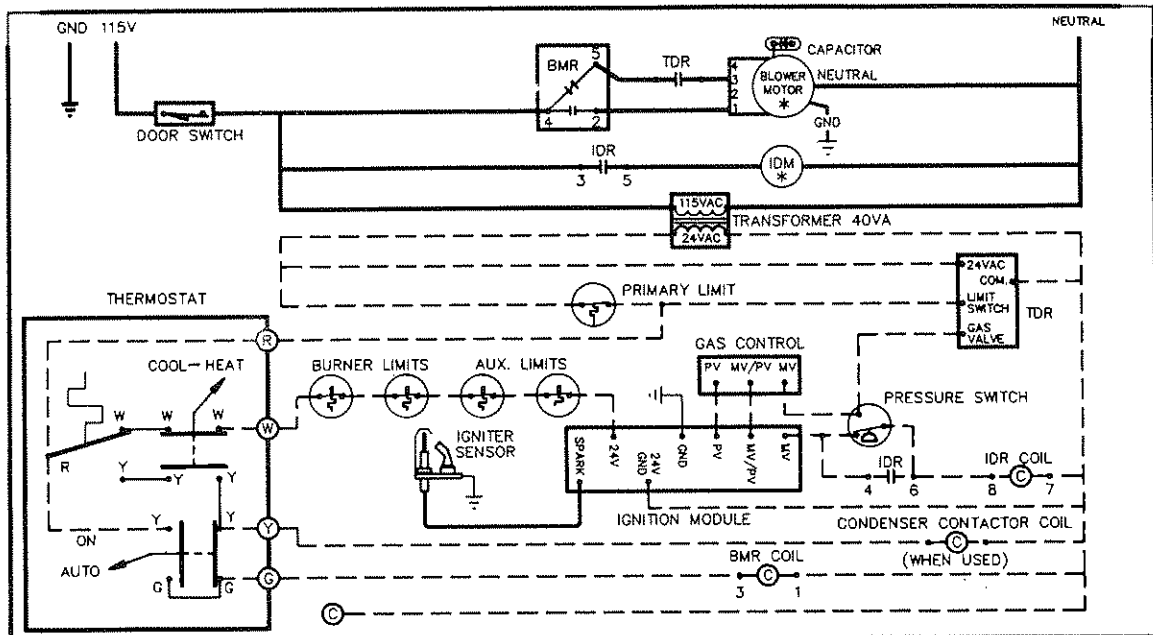

NOTE: FURNACE MUST BE GROUNDED AND CONFORM TO LATEST N.E.C. AND LOCAL CODES

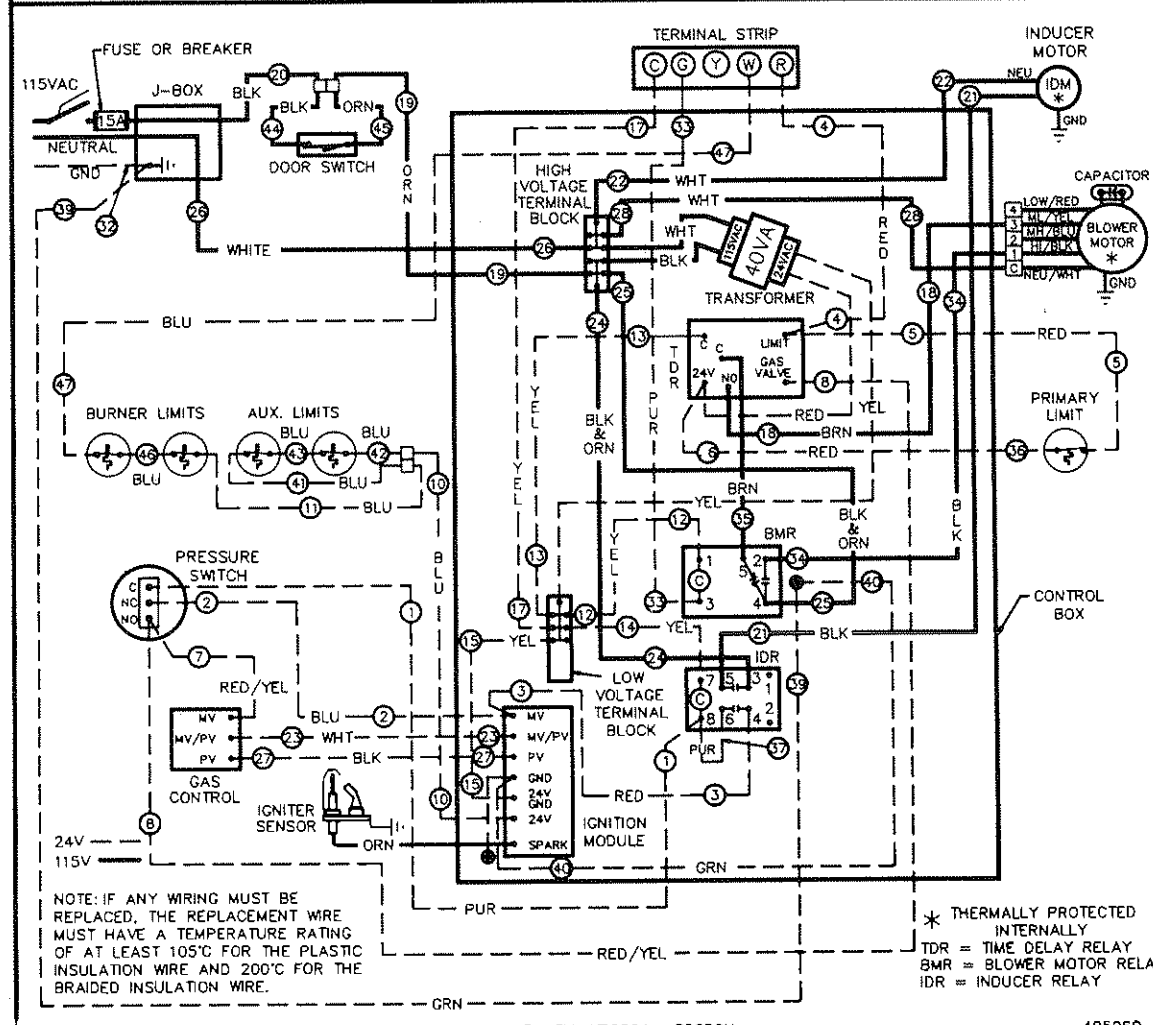

NOTE: IF ANY WIRING MUST BE REPLACED, THE REPLACEMENT WIRE MUST HAVE A TEMPERATURE RATING OF AT LEAST 105°C FOR THE PLASTIC INSULATION WIRE AND 200°C FOR THE BRAIDED INSULATION WIRE.

\* THERMALLY PROTECTED INTERNALLY  
 TDR = TIME DELAY RELAY  
 BMR = BLOWER MOTOR RELAY  
 IDR = INDUCER RELAY

910604

HONEYWELL VR8204M-SB6DDH

405060

FIGURE 23

**EXTERNAL STATIC PRESSURE  
(Inches of Water Column)**

*INPUT (BTU/HR)	MINIMUM	MAXIMUM
40,000	0.10	0.50
60,000	0.12	0.50
80,000	0.12	0.50
100,000	0.15	0.50
120,000	0.20	0.50
140,000	0.20	0.50

\*Input is on furnace rating plate on blower door.

**FIGURE 24**

**A. Supply air duct work.**

**NOTE:** Supply air duct (plenum) connection must be the same size as the furnace supply air opening. Attach to furnace duct flanges.

If you install furnace in horizontal position with an air conditioner, design a minimum 18" long transition that allows free air flow through furnace and cooling coil. Make sure furnace temperature rise is within range noted on furnace rating plate. Also, consult air conditioner's duct work installation instructions.

Seal supply air duct work to furnace casing, walls, ceilings or floors it passes through. End duct work outside furnace space.

**B. Return air duct work.**

1. In upflow position, return air duct must be a minimum depth of 23-31/32". See Figure 25.
2. In downflow position, return air duct must be a minimum 19-7/8" inside depth. See Figure 26.

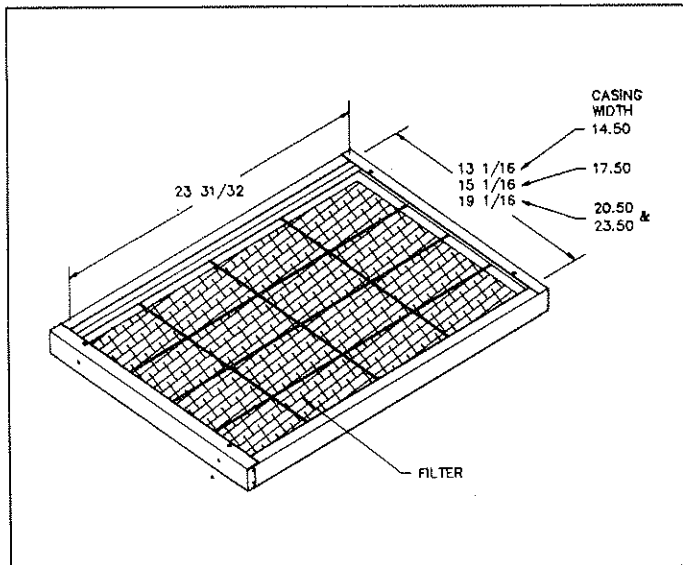

**FIGURE 25**

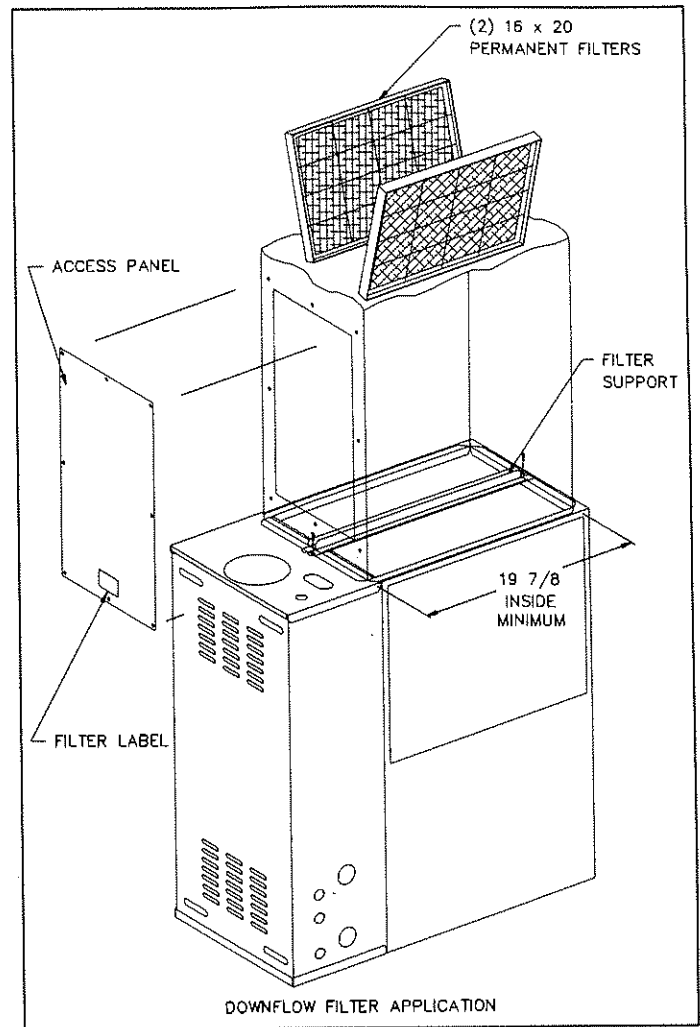

**FIGURE 26**

**NOTE:** In upflow position, if bottom return air is not used, you must attach a solid bottom closure panel to bottom return air opening. Bottom closure panel is available from manufacturer as follows:

BTU/HR* INPUT	MOTOR* H.P.	BOTTOM CLOSURE PART NUMBER
40,000	1/4	4045900
40,000	1/3	
60,000	1/4	
60,000	1/3	
60,000	1/2	4045901
80,000	1/4	4045900
80,000	1/3	
80,000	1/2	4045901
80,000	3/4	4045902
100,000	1/3	4045901
100,000	1/2	
100,000	3/4	4045902
120,000	1/2	
120,000	3/4	
140,000	3/4	4045903
140,000	3/4	

\*See furnace rating plate on blower door.



**WARNING:** Failure to install bottom closure panel could allow combustion products to enter circulating air stream, resulting in injury or death.

When furnace is installed so that supply air ducts carry air to areas outside the space containing the furnace, return air must also be handled by a duct(s) sealed to furnace casing and terminating outside the space containing furnace.

Avoid vent system reverse pressure by running return air duct work outside furnace space. Seal return air duct work to furnace casing, walls, ceilings or floors it passes through. End duct work outside furnace space.

**WARNING:** Failure to seal return air duct work could allow combustion products to enter circulating air stream through air stream leaks, resulting in injury or death.

### C. Duct dampers.

You may balance air flow with dampers installed in each branch run duct and adjust for even temperature throughout the heated space. For proper furnace operation, make sure:

- Supply air registers and return air grilles are open;
- Rugs, carpets, drapes or furniture are clear of registers and grilles;
- Size and shape of supply air plenum is correct;
- Number of supply air ducts is correct;
- You consider your own experience and seek assistance if needed.

### D. Common duct work.

If furnace will share common duct work with a separate cooling unit, install furnace parallel to or upstream of cooling unit. This avoids condensation in heating element. Do not install cooling coil in return air duct work.

With parallel flow, dampers or other means must prevent chilled air from entering furnace. If dampers or other means are not in full heat or cool position, furnace or cooling unit must not operate.

## SECTION 17 — SELECTING AND INSTALLING FILTER CABINETS.

**CAUTION:** You must install air filters to keep these components clean: blower motor, blower wheel and air conditioning coil, if there is one. Dirty equipment may reduce system efficiency or cause erratic control performance, resulting in damage to blower motor or heat exchanger and air conditioner (if installed).

Do not install air filters inside furnace casing.

There are no air filters shipped with this furnace. Obtain and install correct size filters and proper filter frames. Air velocity must not exceed 300-feet per minute through low velocity disposable filters.

Air velocity must not exceed 650-feet per minute through high velocity cleanable filters. Too small a filter could cause

excess static pressure, adversely affecting furnace and cooling system operation.

Follow minimum sizing and quantity recommendations in Figure 27, as well as the air filter manufacturer's.

*GAS INPUT BTU/HR	*MOTOR H.P.	DISPOSABLE AIR FILTERS	CLEANABLE AIR FILTERS
		(FIELD SUPPLIED) (Two Required) SIZE	(FIELD SUPPLIED) (One Required) SIZE
40,000	1/4	14 X 25 X 1	14 X 25 X 1
40,000	1/3	14 X 25 X 1	14 X 25 X 1
60,000	1/4	14 X 25 X 1	14 X 25 X 1
60,000	1/3	14 X 25 X 1	14 X 25 X 1
60,000	1/2	16 X 25 X 1	16 X 25 X 1
80,000	1/4	14 X 25 X 1	14 X 25 X 1
80,000	1/3	14 X 25 X 1	14 X 25 X 1
80,000	1/2	16 X 25 X 1	16 X 25 X 1
80,000	3/4	20 X 25 X 1	20 X 25 X 1
100,000	1/3	16 X 25 X 1	16 X 25 X 1
100,000	1/2	16 X 25 X 1	16 X 25 X 1
100,000	3/4	20 X 25 X 1	20 X 25 X 1
120,000	1/2	20 X 25 X 1	20 X 25 X 1
120,000	3/4	20 X 25 X 1	20 X 25 X 1
140,000	3/4	20 X 25 X 1	20 X 25 X 1
140,000	3/4	20 X 25 X 1	20 X 25 X 1

\*GAS INPUT and MOTOR H.P. can be found on furnace rating plate.

FIGURE 27

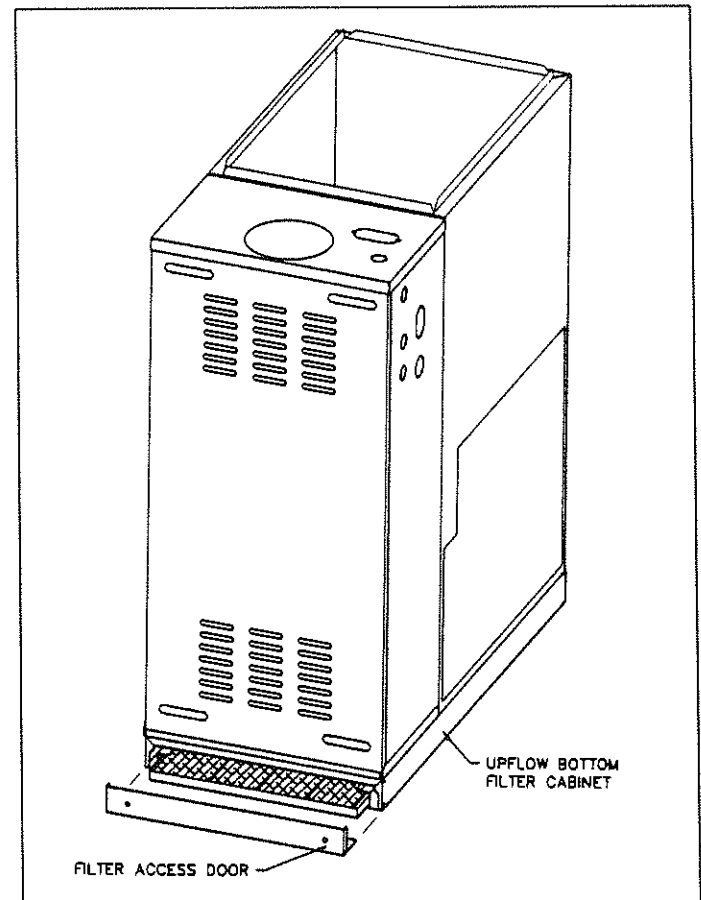

UPFLOW BOTTOM FILTER CABINET  
FIGURE 28

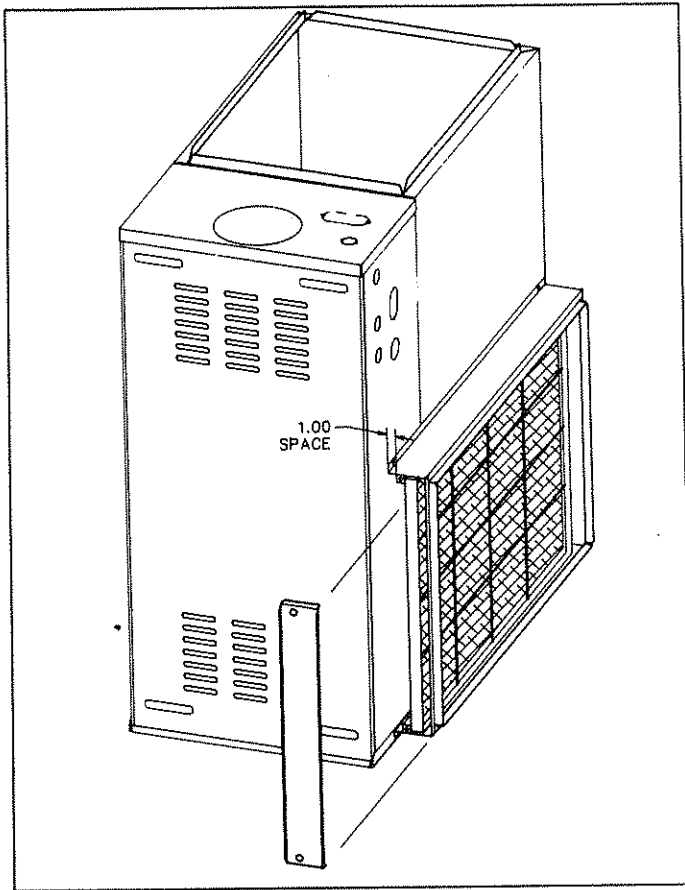

**UPFLOW SIDE FILTER CABINET  
FIGURE 29**

**1. Upflow Positions.**

- a. Upflow position uses a bottom filter cabinet, side filter cabinet or return air filter grille (field supplied).

Manufacturer available bottom and side filter cabinets provide correct filter spacing to assure designed airflow. Field fabricated filter cabinets should allow 1" spacing between filter and furnace.

- b. 1. For upflow side return, use a 16x25 filter.
- 2. For upflow air delivery above 1800 CFM use the following combinations of return air openings:
  - 1. Bottom only or
  - 2. 1 Side and Bottom or
  - 3. Both sides.

Use appropriate filter cabinets with combinations listed above.

- c. See figures 30A and 30B for floor cut out and filter size of bottom filter cabinet available from manufacturer.

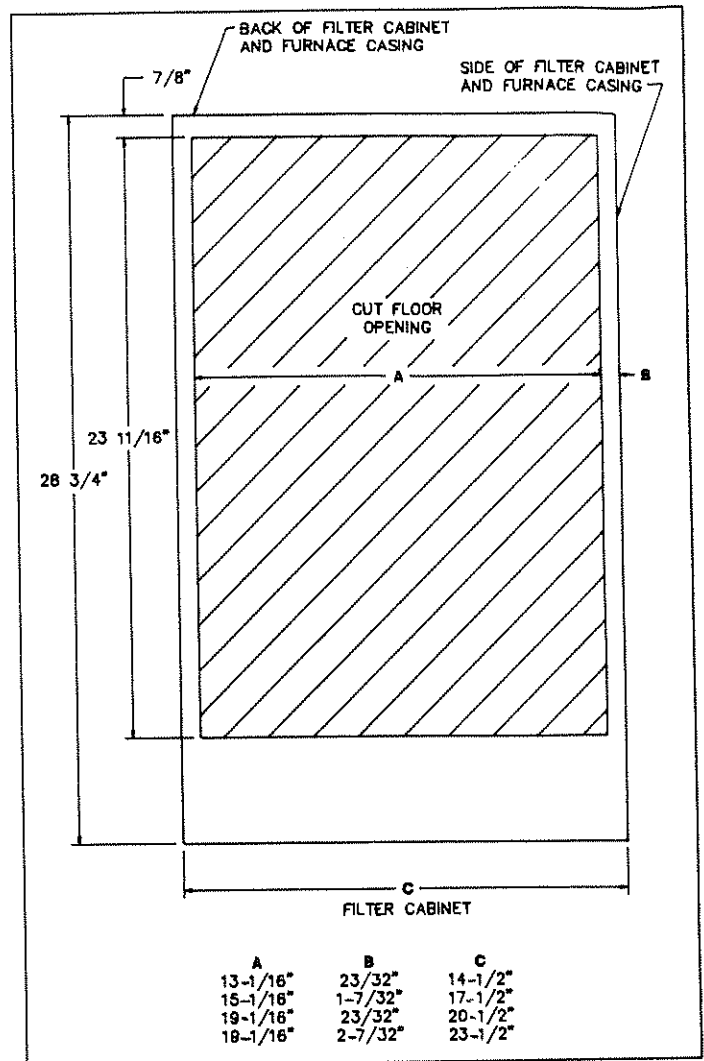

**UPFLOW FLOOR CUT OUT FOR  
BOTTOM FILTER CABINET  
FIGURE 30A**

Bottom Return Filter Sizes		
GAS INPUT *BTU/HR	MOTOR *H.P.	FILTER SIZE
40,000	1/4	14 x 25
40,000	1/3	14 x 25
60,000	1/4	14 x 25
60,000	1/3	14 x 25
60,000	1/2	16 x 25
80,000	1/4	14 x 25
80,000	1/3	14 x 25
80,000	1/2	16 x 25
80,000	3/4	20 x 25
100,000	1/3	16 x 25
100,000	1/2	16 x 25
100,000	3/4	20 x 25
120,000	1/2	20 x 25
120,000	3/4	20 x 25
140,000	3/4	20 x 25
140,000	3/4	20 x 25

\*See furnace rating plate located on blower door.

**FIGURE 30B**

**NOTE:** Bottom and side filter cabinets available from manufacturer have a 1 inch space between furnace casing and filter for increased filter area. Placing filter (field-supplied) directly against furnace bottom or side will decrease airflow and adversely affect furnace operation. Allow 1 inch clearance from furnace filter (field-supplied) to furnace.

**2. Horizontal Position.**

Horizontal position should use an appropriately sized and installed return air filter grille or duct work air filter.

**3. Downflow Position.**

Downflow position furnaces use (2) 16 x 20 filters.

For downflow position, install filter support in return air plenum or use return air filter grille. Downflow filter support and filter kit is available from manufacturer.

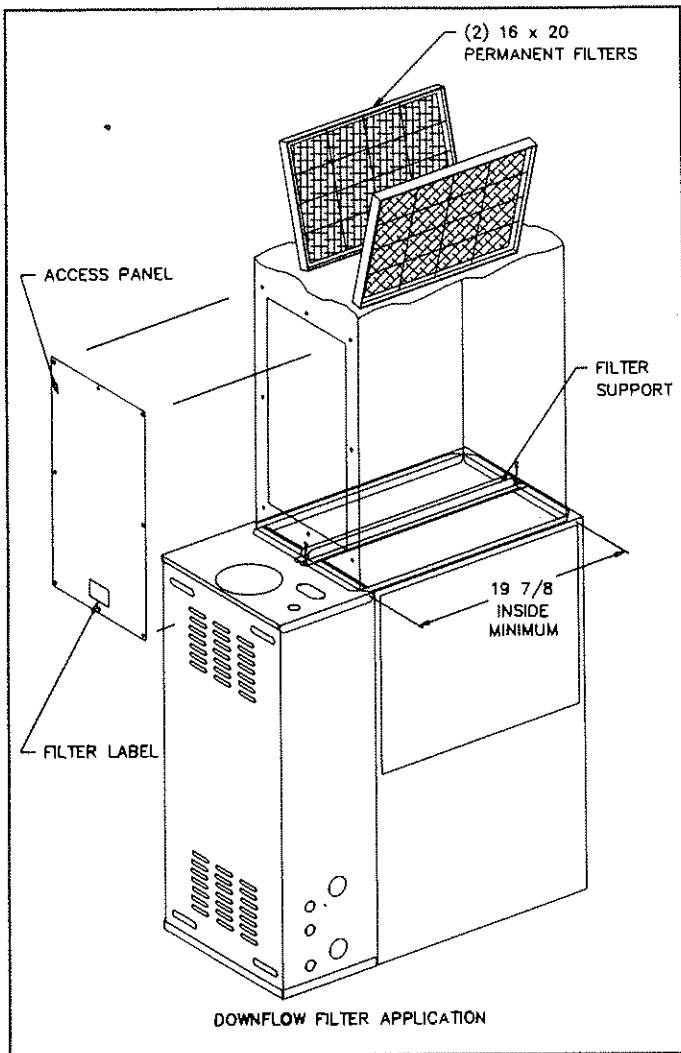

**DOWNFLOW FILTER ARRANGEMENT  
FIGURE 31**

To inspect, replace or clean air filters, follow Users' Information Manual instructions.

**SECTION 18 — CHECKS BEFORE STARTING FURNACE.**

Before starting furnace for the first time, be sure you can answer "Yes" to each of these questions:

1. Is furnace properly equipped to operate with available fuel? See Section 2.
2. Is furnace level? See Section 4.
3. Have you cleared away all loose construction and insulation materials? See Section 6.
4. Is furnace installed with proper clearances to combustible materials? See Section 6.
5. If furnace is in crawl space, is it sufficiently elevated above the ground? See section 6.
6. Does furnace have sufficient combustion and ventilation air? See Section 8.
7. Does vent system meet current National Fuel Gas Code ANSI Z223.1/NFPA 54 and local codes? See Section 9.
8. Is vent connection securely fastened to draft inducer collar? See Section 9.
9. Did you completely check gas pipe and controls for gas leaks? See Section 11.
10. Does electrical wiring follow current National Electrical Code ANSI/NFPA 70 as well as local codes? See Section 12.
11. Is furnace electrically grounded? See Section 12.
12. Is room thermostat properly installed and heat anticipator set correctly? See Section 14.
13. Is duct work system correctly sized and sealed? See Section 16.
14. Are air filters in place and correctly sized? See Section 17.
15. Are proper filter frames or filter supports installed? See Section 17.
16. On furnace installations above a 2000-foot elevation, is furnace derated properly? See Section 23.

**SECTION 19 — ADJUSTING PILOT.**

Equipment needed: Save time by getting these tools before you start: Item number(s) 9,10,14,15,19 and 23 listed in Section 10.

**NOTE:** To purge gas lines, it may be necessary to operate furnace through more than one lockout cycle at start-up.

**WARNING:** You must have correct gas supply line and pilot gas pressures. Correct pressures give proper pilot ignition and burner operation. Use a "U" tube water manometer to measure actual gas pressure. Failure to accurately adjust pressure could cause a fire or explosion resulting in damage, injury or death.

**A. Gas supply line pressure.**

1. Turn off gas at manual shut-off valve in gas supply line just ahead of furnace.
2. Remove inlet pressure plug from gas control.

3. Make sure valve is in off position, then install 1/8"-pipe manual shut-off valve in hole vacated by plug.
4. Attach "U" tube water manometer to 1/8"-pipe manual shut-off valve just installed.
5. Open manual shut-off valve in gas supply line just ahead of furnace.
6. Open 1/8"-pipe manual shut-off valve leading to "U" tube water manometer.
7. Turn on all gas appliances attached to gas supply line.
8. With furnace operating, read gas supply line pressure on manometer.
  - a. Gas supply line pressure must not exceed 10.5 inches W.C. for natural gas.
  - b. Gas supply line pressure must not exceed 13 inches W.C. for propane (LP) gas.
9. If gas supply line pressure is not within these limits, call gas supplier.
10. Turn off all gas appliances attached to gas supply line.

#### B. Pilot flame adjustment.

Before adjusting pilot flame, confirm that gas supply line pressure is correct, as explained in paragraph A) above, then proceed:

1. Open manual shut-off valve located in gas supply line just ahead of furnace.
2. If necessary, adjust spark gap to 3/16" as shown in Figure 32. Pilot flame should cover 1/2" of tip of flame sensor.

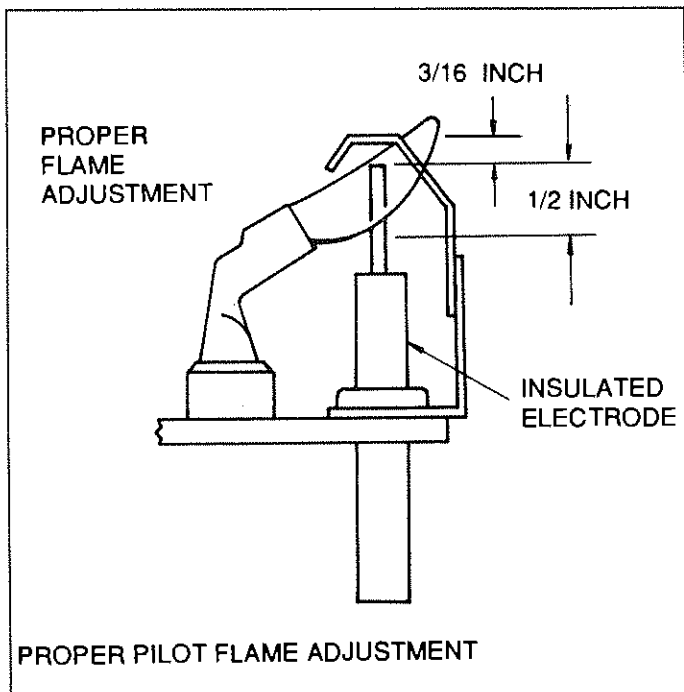

FIGURE 32

3. Disconnect pressure switch, red/yellow, #7/#8 piggy-back wire from pressure switch, terminal "N.O."
4. Start furnace following Operating Instructions on front door. Pilot will light; after delay, inducer blower will come on, but main burners will not light.
5. Pilot flame should cover 1/2" of tip of flame sensor as shown in Figure 32.
6. If you need to adjust pilot flame, remove pilot adjustment cover screw on gas control. Save screw for reinstallation. Turn inner adjustment screw clockwise -> to decrease pilot flame; counter-clockwise <- to increase pilot flame. Install cover screw and tighten to torque of 5 inch-pounds to prevent gas leakage.
7. Shut off furnace. Connect pressure switch, red/yellow, #7/#8 piggyback wire to pressure switch, terminal "N.O."
8. If you will not be checking gas input now, turn off gas. Use manual shut-off valve in gas supply line just ahead of furnace. Remove shut-off valve from gas control inlet pressure tap. Install pressure tap plug. Turn on gas.
9. Check pilot adjustment cover screw and gas control inlet pressure tap plug for gas leaks. Use a commercial soap solution made for leak detection.

**WARNING:** Never use an open flame to check for gas leaks. A gas leak could cause a fire or explosion, resulting in damage, injury or death.

## SECTION 20 — ADJUSTING MANIFOLD PRESSURE.

Equipment Needed: Save time by getting these tools before you start: Item number(s) 9,10,11,15,19 and 23 listed in Section 10.

**WARNING:** Correct manifold pressure is necessary for proper ignition and burner operation. Use a "U" tube water manometer to measure actual gas pressures. Failure to accurately adjust pressure could cause heat exchanger failure, asphyxiation, fire or explosion, resulting in damage, injury or death.

#### A. Normal manifold pressure (gas control outlet pressures).

Gas Supply	Normal
Natural gas	3.5 inches W.C.
Propane (LP) gas	10.0 inches W.C.

**CAUTION:** Many installers' set Propane (LP) manifold pressure at 11.0 inches W.C. Do not do this. It could cause heat exchanger failure or nuisance callbacks.

Check gas supply line pressure first, following instructions in Section 19A.

#### B. Connect a "U" tube water manometer to measure manifold pressure:

1. Turn off gas at manual shut-off valve located in gas supply line just ahead of furnace.

2. Remove outlet pressure tap plug from gas control.
3. Make sure shut-off valve is in off position, then install 1/8"-pipe manual shut-off valve in hole vacated by plug.
4. Attach "U" tube water manometer to 1/8"-pipe manual shut-off valve just installed.
5. Turn on all gas appliances attached to gas supply line.
6. Open manual shut-off valve in gas supply line just ahead of furnace. Start furnace following Operating Instructions on front door.
7. Open 1/8"-pipe manual shut-off valve leading to manometer.
8. Read manifold pressure on manometer.
9. Make small changes in manifold pressure within allowable range (3.2 inches W.C. to 3.8 inches W.C.) by turning gas control regulator adjusting screw clockwise -> to increase pressure; turn counter-clockwise <- to decrease pressure. Make major changes in flow rate by changing main burner orifice size. See Section 23.
10. Turn off gas at manual shut-off valve in gas supply line just ahead of furnace. Install outlet pressure tap plug in gas control. Turn on gas.
11. Check regulator adjustment cover screw and gas control plug for gas leaks. Use a commercial soap solution made for leak detection.

**WARNING:** Never use an open flame to check for gas leaks. A gas leak could cause a fire or explosion resulting in damage, injury or death.

## SECTION 21 — CHECKING GAS INPUT.

Equipment Needed: Save time by getting these tools before you start: Item number(s) 11,14,15,19 and 22 listed in Section 10.

**WARNING:** Natural gas heating value (BTU/cu.ft.) can vary significantly, therefore, it is the installers' responsibility to see that BTU input to furnace is adjusted properly. Failure to do so could cause heat exchanger failure, asphyxiation, fire or explosion, resulting in damage, injury or death.

Underfiring could cause inadequate heat, excessive condensation or ignition problems. Overfiring could cause sooting, flame impingement or overheating of heat exchanger.

### A. Natural Gas.

**NOTE:** For operations above 2,000 feet elevation, follow instructions in Section 23.

Before starting natural gas input check, obtain gas heat value at standard conditions from local supplier.

1. Make sure gas piping is large enough for all appliances connected to it to operate at once without lowering main line pressure. Failure to do so could

cause lighting or burning problems on any of the appliances.

2. Make sure gas control inlet pressure does not exceed 10.5 inches W.C. Use method in Section 19A to check gas supply line pressure.
3. Make sure all other gas appliances are off. You may leave pilots on. Start furnace following Operating Instructions on front door or in Users' Information Manual.
4. As furnace warms up, watch gas supply line (gas control inlet) pressure using "U" tube water manometer installed in gas control inlet pressure tap. Natural gas supply line pressure must still not exceed 10.5 inches W.C.
5. After verifying correct gas control inlet pressure, close shut-off valve in gas control inlet pressure tap. Move manometer connection to gas control outlet pressure tap. See Section 20. Open shut-off valve in outlet pressure tap. Let furnace warm up for 6 minutes.
6. Manifold pressure should be 3.5 inches W.C. Adjust by removing regulator cover screw on gas control. Save screw for reinstallation. Turn inner adjustment screw counter-clockwise <- to decrease manifold pressure; turn clockwise -> to increase manifold pressure. Set correct manifold pressure. Install cover screw and tighten to torque of 5 inch-pounds to prevent gas leakage.
7. Locate gas meter. Determine which dial has the least cubic feet of gas and how many cubic feet per revolution it represents. This is usually one-half, one or two cubic feet per revolution.
8. With stopwatch, measure time it takes to consume two cubic feet of gas.

- a. If dial is one-half-cubic foot per revolution, measure time for four revolutions.
- b. If dial is one-cubic foot per revolution, measure for two revolutions.
- c. If dial is two-cubic feet per revolution, measure for one revolution.
- d. After determining the number of seconds for two cubic feet of gas to flow through meter, divide this time by two. This gives average time for one cubic foot of gas to flow through meter.

Example:

If it took 58 seconds for two-cubic feet to flow, it would take 29 seconds for one-cubic foot to flow.

9. a. Use this formula to calculate gas input:

$$\text{Gas Input} = \frac{\text{Gas BTU/CU.FT.} \times 3,600}{\text{seconds per/hour}} \div \frac{\text{Seconds for one cubic foot of gas}}{1} = \text{Btuh}$$

Example:

Assume it took 29 seconds for one cubic foot of gas to flow and heating value of 1,000 BTU/ CU.FT.

$$\text{Gas Input} = \frac{1,000 \times 3,600}{29} = 124,138 \text{ Btuh}$$

If you left no other pilots on, this is the furnace gas input.

- b. If you left water heater, dryer or range pilots on, allow for them in calculating correct furnace gas input. A quick way is to allow 1,000 Btuh for a water heater. Allow 500 Btuh for dryer and 500 Btuh for each range burner pilot.

Example:

If you left gas water heater, dryer, four range burner pilots and one oven pilot on, allow:

Water heater pilot	1,000 Btuh
Dryer pilot	500 Btuh
4 range burner pilot	2,000 Btuh
1 range oven pilot	500 Btuh
	4,000 Btuh

Subtracting 4,000 Btuh from 124,138 Btuh measured above equals 120,138 Btuh. This would be the correct furnace gas input after allowing for pilots left on.

- 10. Manifold pressure may be adjusted within the range of 3.2 inches W.C. to 3.8 inches W.C. to get rated input. If you cannot get rated input with manifold pressure within the allowable range, you will need to change orifices. See Section 23.
- 11. Turn off gas. Remove 1/8"-pipe manual shut-off valves you used. Install 1/8"-pipe plugs in gas control inlet and outlet pressure taps. Tighten to torque of 50 inch-pounds. Turn on gas. Check both pipe plugs for gas leaks. Use a commercial soap solution made for leak detection.

**WARNING:** Never use an open flame to check for gas leaks. A gas leak could cause a fire or explosion, resulting in damage, injury or death.

B. Propane (LP) Gas.

**WARNING:** Propane (LP) gas installations do not have gas meters to double check input rate. Measure manifold pressure adjustment with an accurate "U" tube water manometer. Failure to accurately adjust pressure could cause heat exchanger failure, asphyxiation, fire or explosion, resulting in damage, injury or death.

**NOTE:** For operation at elevations above 2,000 feet, follow instructions in Section 23.

- 1. Make sure you have correct pilot orifice and main burner orifices. Be sure that gas piping is large enough for all appliances connected to it to operate at once without lowering the main line pressure. Failure to do so could cause lighting or burning problems on any of the appliances.
- 2. Gas control inlet pressure must be between 11 inches and 13 inches for propane (LP) gas. See Section 19A to check gas supply line pressure.
- 3. Turn off all other gas appliances. Pilots may be left on. Start furnace following Operating Instructions on front door or in Users' Information Manual.
- 4. As furnace warms up, watch gas supply line (gas control inlet pressure) using "U" tube water manometer in gas control inlet pressure tap. See Section 19A. Supply line pressure must still be between 11 inches and 13 inches W.C. for propane (LP) gas.
- 5. After verifying correct gas control inlet pressure, close shut-off valve in gas control inlet pressure tap. Move manometer to gas control outlet pressure tap. See Section 20. Open shut-off valve in gas control outlet pressure tap. Let furnace warm up for 6 minutes.
- 6. Manifold pressure should be 10.0 inches W.C. +/- 0.3 inches W.C. Adjust by removing regulator cover screw on gas control. Save screw for reinstallation. Turn inner adjustment screw counter-clockwise <- to decrease manifold pressure; turn clockwise -> to increase manifold pressure. Set correct manifold pressure. Install cover screw and tighten to torque of 5 inch-pounds to prevent gas leakage.
- 7. Turn off gas before removing the 1/8"-pipe manual shut-off valves. Install 1/8"-pipe plugs in gas control inlet and outlet pressure taps. Tighten to torque of 50 inch-pounds. Turn on gas. Check both pipe plugs for gas leaks. Use a commercial soap solution made for leak detection.

**CAUTION:** Many installers' set propane (LP) manifold pressure at 11.0 inches W.C. Do not do this. It could cause heat exchanger failure or nuisance callbacks.

**WARNING:** Propane (LP) gas installations do not have gas meters to double check input rate. You must measure manifold pressure adjustment with an accurate "U" tube water manometer. Failure to accurately adjust pressure could cause heat exchanger failure, asphyxiation, fire or explosion, resulting in damage, injury or death.

**WARNING:** Never use an open flame to check for gas leaks. A gas leak could cause a fire or explosion resulting in damage, injury or death.

## SECTION 22 — ORIFICE SIZE.

See Figure 33 for initial gas orifice sizes as shipped from factory.

Initial Orifice Size		
*Input BTU/HR	Natural Gas *Orifice Size	Propane Orifice Size
All size units	2.15mm	1.30mm
*See furnace rating plate located on blower door.		

FIGURE 33

Check with your local gas supplier to determine heat value (BTU/CU.FT.) of gas in your area. Depending on your local heat value and elevation, you may need to adjust manifold pressure or change orifices to get proper gas input rate. See Section 23.

## SECTION 23 — DERATING FOR HIGH ALTITUDES.

Equipment Needed: Save time by getting these tools before you start: Item number(s) 3,7 and 23 listed in Section 10.

### A. Installer responsibility.

For operation at elevations above 2,000 feet the den-

sity of air is reduced, therefore, the furnace should be derated at the rate of four percent (4%) for each 1,000 feet above sea level. It is the installers' responsibility to see that the input is adjusted properly.

If the gas supplier has not already derated the gas BTU value, derating must be achieved by reducing the size of the main burner orifices. See Table 34 and 35 for proper sizing. Contact gas supplier for more information.

Adjustment of the manifold pressure to a lower pressure reading than what is specified in Section 20, **Manifold Pressure Adjustment** of this manual is considered to be an improper derate procedure. With a lower density of air and a lower manifold pressure at the burner orifice, the orifice will not aspirate the proper amount of primary air into the burner. Insufficient primary air can cause incomplete combustion, yellow tipping and quite possibly carbon build-up.

### B. New orifice size.

See appropriate chart below to determine new orifice size.

To accomplish altitude derate, a natural gas orifice kit containing the natural gas orifices indicated in Figure 34 is available through your supplier. A similar propane (LP) gas orifice kit is available. Individual orifices are also available in a convenient lot size. Use only these orifices to assure proper performance.

NATURAL GAS—ORIFICE SIZE CHART									
Gas Heat* Value BTU/CU.FT.	Elevation								
	Up to to 2000 Feet	2001 to 3000 Feet	3001 to 4000 Feet	4001 to 5000 Feet	5001 to 6000 Feet	6001 to 7000 Feet	7001 to 8000 Feet	8001 to 9000 Feet	9001 to 10000 Feet
800-849	2.35mm	2.30mm	2.30mm	2.25mm	2.20	2.20mm	2.15mm	2.10mm	2.05mm
850-899	2.30mm	2.25mm	2.20mm	2.20mm	2.15mm	2.10mm	2.10mm	2.05mm	2.00mm
900-949	2.25mm	2.20mm	2.15mm	2.15mm	2.10mm	2.05mm	2.05mm	2.00mm	1.95mm
950-999	2.20mm	2.15mm	2.10mm	2.05mm	2.05mm	2.00mm	1.95mm	1.95mm	1.90mm
1000-1049	2.15mm	2.10mm	2.05mm	2.05mm	2.00mm	2.00mm	1.95mm	1.90mm	1.85mm
1050-1100	2.10mm	2.05mm	2.00mm	2.00mm	1.95mm	1.90mm	1.90mm	1.85mm	1.85mm

\*At standard conditions: 30.0 inches Mercury, 60°F, Saturated.

NOTE: Shaded orifices above are not included in natural gas orifice kit. They are available separately.

FIGURE 34

PROPANE (LP) GAS—ORIFICE SIZE CHART									
Gas Heat* Value BTU/CU.FT.	Elevation								
	Up to to 2000 Feet	2001 to 3000 Feet	3001 to 4000 Feet	4001 to 5000 Feet	5001 to 6000 Feet	6001 to 7000 Feet	7001 to 8000 Feet	8001 to 9000 Feet	9001 to 10000 Feet
40,000-140,000	1.30mm	1.25mm	1.25mm	1.20mm	1.20mm	1.20mm	1.15mm	1.15mm	1.10mm

FIGURE 35

NOTE: All orifices above are included in propane (LP) gas orifice kit.

### C. Changing orifices.

**WARNING:** Before changing orifices, turn off electrical power and gas. Failure to do so could result in electrical shock or gas leak, resulting in damage, injury or death.

1. Set room thermostat to its lowest or off setting.
2. Turn off electricity at electrical disconnect switch next to furnace.
3. Turn off manual shut-off valve in gas supply line just ahead of furnace.
4. Turn gas control knob clockwise -> to OFF position.
5. Starting with burner farthest from gas control, remove burner screws and burners. Burners overlap. Burner farthest from gas control is on top. See Figure 36.
6. Remove original gas orifices.
7. First, hand thread new orifices into manifold. Do not cross-thread; then tighten to torque of 50 inch-pounds.

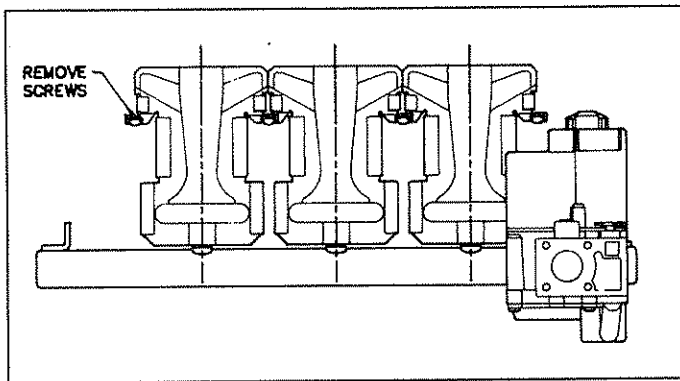

**FIGURE 36**

8. Replace burners in reverse order from instructions in Step 5.
9. Check burner carryover alignment. They should be touching but not overlap adjacent burner. Replace screws.
10. Turn gas control knob counter-clockwise <- to ON position.
11. Open manual shut-off valve in gas supply line just ahead of furnace.
12. Set room thermostat to its highest setting.
13. Turn on electricity at electrical disconnect switch located next to furnace.
14. Check for gas leaks using commercial soap solution made for leak detection.

**WARNING:** Never use an open flame to check for gas leaks. A gas leak could cause a fire or explosion resulting in damage, injury or death.

15. Check gas input following Section 21.

### SECTION 24 — ADJUSTING BLOWER SPEED..

**CAUTION:** Heating speed tap should not be reduced below initial factory setting. Reducing speed tap setting may result in inadequate air circulation, and could cause excessive air temperature rise through furnace. This could cause high-temperature limit switch to cycle burners on and off. This could reduce furnace efficiency and shorten life of heat exchanger and blower motor.

1. All models have four blower speeds available for use.

Motor speed designations are:

- #1. High Speed (HI)
- #2. Medium High Speed (MH)
- #3. Medium Low Speed (ML)
- #4. Low Speed (LOW)

2. Determine initial heating and cooling speeds in system design stage. See Product Data sheet for air-flow data. Depending on test results performed in Sections 25 and 26, you may need to change blower motor speed.
3. Turn off electricity at electrical disconnect switch next to furnace.

**WARNING:** Failure to turn off electrical power to furnace before changing blower motor speed could cause electrical shock resulting in damage, injury or death.

4. Make blower speed changes at connector block located at side of blower door. See Figure 37A.

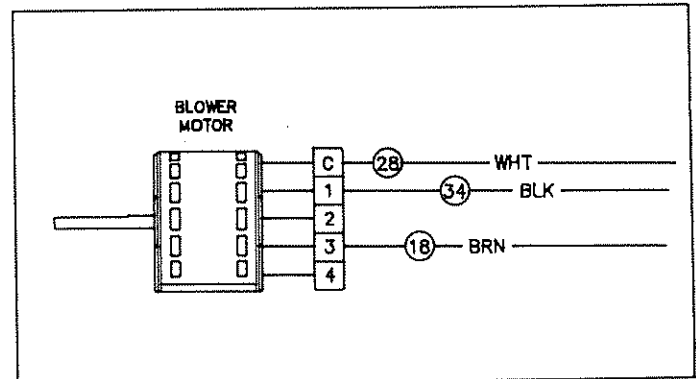

**FIGURE 37A**

5. Never change the "C" common (WHT) wire.
6. To change cooling speed, black wire is moved to desired speed. Cooling speed is controlled through blower motor relay (BMR).
7. To change heating speed, brown wire is moved to desired speed. Heating speed is controlled through time delay relay (TDR). Heating speed should not be reduced below initial factory setting.



8. Turn on electricity at electrical disconnect switch located next to furnace.

**SECTION 25 — MEASURING DUCT WORK STATIC PRESSURE.**

Equipment Needed: Save time by getting these tools before you start: Item number(s) 20 listed in Section 10.

**CAUTION:** High duct work static pressure may cause low airflow resulting in poor heating performance and reduced heat exchanger life. Low airflow may also cause poor cooling performance.

**A. Preparing to measure duct work static pressure.**

1. Open supply air registers and return air grilles. Make sure the registers and grilles are free of obstruction from rugs, carpets, drapes or furniture.
2. Set balancing dampers in supply duct system.
3. Check duct work for obstructions or leaks.
4. Make sure filters are clean and in place. See Section 17 for filter information.
5. Make sure that blower speed taps are set for proper heating and cooling. For heating operation, initial speed tap should be set in accordance with Figure 37B. For cooling operation, initial speed tap should be set in accordance with Figure 38. Refer to Section 24 for adjusting blower speed.

Air Temperature Rise Range and Heating Operation Speed Taps		
**BTU/HR / Motor Input / HP	Air Temperature Rise Range (°F)	Heating Operation *Speed Tap
40,000 / 1/4	50-80	LO
40,000 / 1/3	30-60	LO
60,000 / 1/4	45-75	ML
60,000 / 1/3	45-75	LO
60,000 / 1/2	35-65	LO
80,000 / 1/4	50-80	MH
80,000 / 1/3	40-70	MH
80,000 / 1/2	50-80	LO
80,000 / 3/4	40-70	LO
100,000 / 1/3	55-85	MH
100,000 / 1/2	50-80	ML
100,000 / 3/4	40-70	ML
120,000 / 1/2	45-75	MH
120,000 / 3/4	45-75	MH
140,000 / 3/4	45-75	MH
140,000 / 3/4	50-80	MH

\* These are initial Factory Settings.  
 \*\* See Furnace Rating Plate for BTU/HR input and Motor H.P.

**FIGURE 37B**

**a. Heating.**

1. Measure duct work static pressure with circulating air blower on heating speed. Follow instructions below.
2. Measure air temperature rise with circulating air blower on heating speed. See Section 26.

**b. Air Conditioning.**

1. Measure duct work static pressure with circulating air blower on air conditioning speed. Follow instructions below.
2. Measure air temperature rise with circulating air blower on heating speed. See Section 26.

Air Conditioning Operation Speed Tap Settings with 0.5" W.C. Ductwork Static Pressure								
*BTU/HR / Motor Input / HP	Air Conditioning Tonnage							
	1—1/2	2	2—1/2	3	3—1/2	4	5	
40,000 / 1/4	MH	HI	—	—	—	—	—	
40,000 / 1/3	—	ML	MH	HI	—	—	—	
60,000 / 1/4	MH	HI	—	—	—	—	—	
60,000 / 1/3	—	ML	MH	HI	—	—	—	
60,000 / 1/2	—	—	—	ML	MH	HI	—	
80,000 / 1/4	HI	HI	—	—	—	—	—	
80,000 / 1/3	LO	ML	HI	HI	—	—	—	
80,000 / 1/2	—	—	—	ML	MH	HI	—	
80,000 / 3/4	—	—	—	—	ML	MH	HI	
100,000 / 1/3	LO	ML	HI	HI	—	—	—	
100,000 / 1/2	—	LO	MH	MH	HI	—	—	
100,000 / 3/4	—	—	—	LO	MH	MH	HI	
120,000 / 1/2	—	—	LO	ML	HI	HI	—	
120,000 / 3/4	—	—	—	LO	ML	HI	HI	
140,000 / 3/4	—	—	LO	ML	HI	HI	—	
140,000 / 3/4	—	—	—	LO	ML	HI	HI	

\* See furnace rating plate for BTU/HR input and motor H.P.

This table only gives initial speed tap settings for installations with ductwork static pressure of 0.5" W.C. figuring 400 CFM per ton of air conditioning. Ductwork with higher than 0.5" W.C. static pressure will cause reduced airflow and these speed tap settings will not be correct. To determine correct speed tap settings at ductwork static pressures above 0.5" W.C., see Product Data Sheet.

**FIGURE 38**

**B. Measuring duct work static pressure.**

1. Place slope gauge near furnace where level and adjust scale to read 0.00 inches W.C.
2. Insert one static pressure tap into supply air transition duct between furnace and cooling coil or in the supply air plenum for heating only systems. Insert other static pressure tap in return air plenum. See Figure 39.

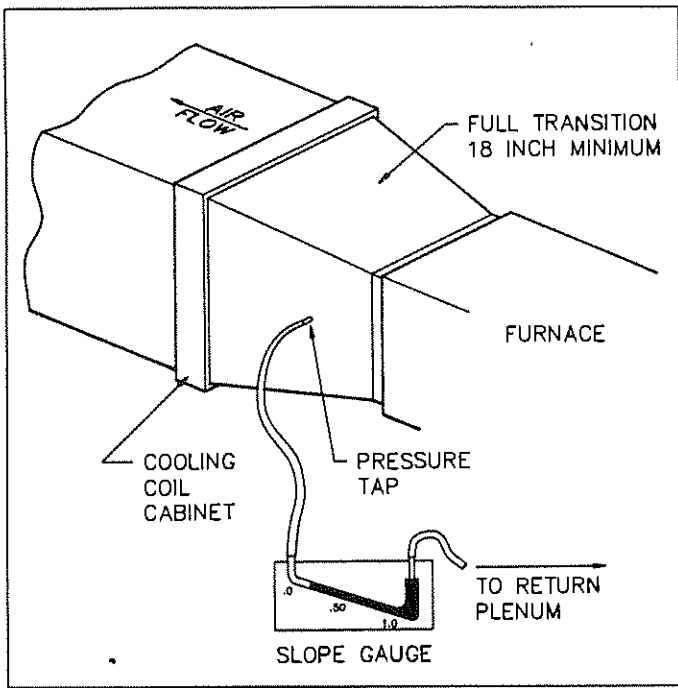

**FIGURE 39**

3. Connect pressure tap attached to supply air transition duct (warm air supply plenum) to positive pressure side of slope gauge (bottom of scale). See Figure 39.
4. Connect pressure tap attached to return air plenum to negative pressure side of slope gauge (top of scale). See Figure 39.
5. Start blower on cooling speed by jumping terminals "R" and "G" on 24 volt terminal strip located on furnace control box.
6. With blower running, read duct work static pressure from slope gauge.

**NOTE:** If air filter location is upstream of return air pressure tap, duct work static pressure must be adjusted by subtracting 0.08 inches W.C. to get actual duct work static pressure.

$$\text{Duct Work Static Pressure} = \text{Measured Pressure} - 0.08 \text{ inches W.C.}$$

7. Duct work static pressure should not exceed 0.5 inches W.C. in order to insure proper volume of air flow.
8. Remove jumper wire between terminals "R" and "G" on 24 volt terminal strip. Remove pressure taps and seal holes in duct work. Failure to seal holes could result in reduced system performance.

## SECTION 26 — MEASURING AIR TEMPERATURE RISE.

Equipment Needed: Save time by getting these tools before you start: Item number(s) 21 listed in Section 10.

### A. Preparing to measure air temperature rise.

Follow Steps 1 through 5 in Section 25A of this Manual.

### B. Measuring air temperature rise.

Air temperature rise (warm air supply temperature minus cold air return temperature) must be within allowable air temperature rise range specified on furnace rating plate and in Figure 37B.

Figure 37B shows heating operation speed tap. Furnace is set on this speed tap when shipped from factory.

1. Place thermometer in supply air plenum approximately 2 feet from furnace. Locate thermometer tip in center of plenum to insure proper temperature measurement.
2. Place thermometer in return air duct approximately 2 feet from furnace. Locate thermometer tip in center of duct to insure proper temperature measurement.
3. Set room thermostat on highest temperature setting. Operate furnace 6 minutes. Record supply air and return air temperatures.
4. Calculate air temperature rise by subtracting return air temperature from supply air temperature.
5.
  - a. If air temperature rise is below maximum temperature rise, heating system has sufficient airflow.
  - b. If air temperature rise is above maximum temperature rise specified in Figure 37B, more heating air flow is needed. Change blower heating speed to a higher setting. Follow instructions in Section 24 to adjust blower speed.

**CAUTION:** Operating furnace above maximum air temperature rise may cause poor heating performance and decreased heat exchanger life.

6. Heating speed tap should not normally be reduced below initial factory setting. Some duct system configurations and supply register locations may result in "cold blow". Setting heating speed tap to next lower speed may resolve this issue.
7. After making heating airflow adjustments, you must check air temperature rise following Steps 3 and 4 above to verify that resulting air temperature is within allowable range.
8. If air temperature rise is still above that specified on furnace rating plate and in Figure 37B, check duct work design with a qualified heating engineer. It may be necessary to resize the duct work. Recheck air temperature rise after revising duct system.
9. Set room thermostat to desired setting.
10. Remove thermometers and seal duct work holes. Failure to seal holes could result in reduced system performance.

## SECTION 27 — CHECKING CONTROLS.

Equipment Needed: Save time by getting these tools before you start: Item number(s) 3 and 18 listed in Section 10.

Before leaving the work site, check to see that all controls are functioning properly.

Follow these steps:

1. Turn off electricity at electrical disconnect switch next to furnace.
2. Turn gas control knob clockwise -> to OFF position.
3. Connect a "U" tube water manometer to gas control outlet (manifold) pressure tap.
4. Set room thermostat to its highest temperature.
5. Turn on electricity at electrical disconnect switch located next to furnace. Electronic ignition lockout module should start to spark pilot ignitor, but pilot burner should not light. Manifold pressure should remain at zero.
6. Electronic ignition lockout module should spark pilot ignitor for given lockout time of module and go into lockout mode. Lockout time for Honeywell S8600H is 90 seconds maximum.  
  
**NOTE:** Honeywell electronic ignition lockout module will stop sparking when module locks out.
7. Turn off electricity at electrical disconnect switch located next to furnace. Turn gas control knob counter-clockwise <- to ON position. Wait 10 seconds for electronic ignition lockout module to reset.
8. Turn on electricity at electrical disconnect switch located next to furnace. Pilot should light from spark and ignite burners. Wait for main blower to start.  
  
**NOTE:** To purge gas lines, it may be necessary to operate furnace through more than one lockout cycle at start-up.
9. Cycle electrical disconnect switch next to furnace on and off. Watch at least three ignition cycles. Pilot should light from spark and light main burners within 10 seconds.
10. Burner flames should look the same with circulation blower on and off. If not, turn gas control knob clockwise -> to OFF position.
11. Turn off electricity at electrical disconnect switch located next to furnace. Disconnect all room thermostat wires at control box terminal strip. To start blower on cooling speed, jump terminal strip, terminals "R" and "G". Turn on electricity at electrical disconnect switch next to furnace.
12. Using a match flame check for air leaks between bulkhead and blower deck, under burners and up each side where bulkhead mounts to casing. Tighten screws until air leaks stop.

13. Turn off electricity at electrical disconnect switch located next to furnace. Remove jumper from terminal strip, terminals "R" and "G". Reconnect all room thermostat wires to original terminal strip, terminals. See Section 13.
14. Remove "U" tube water manometer from gas control and replace outlet pressure tap. Turn gas control knob counter-clockwise <- to ON position.
15. Turn on electricity at electrical disconnect switch next to furnace. With main burners and blower operating, block off all return air grilles to restrict return air. Wait for primary limit control to cycle burners off.
16. Remove all restrictions from return air grilles. When primary limit cools, burners should automatically reignite.
17. Set room thermostat to desired setting.

## SECTION 28 — BLOWER TIMINGS.

Equipment Needed: Save time by getting these tools before you start: Item number(s) 5 listed in Section 10.

1. Blower on-time setting of heating relay is fixed at 20 to 30 seconds and is not field adjustable.
2. Blower off-time setting is adjustable through a range of 60 to 180 seconds. Blower off-time is factory set at 180 seconds.
3. If a shorter blower off-time is desired:
  - a. Turn off electricity at electrical disconnect switch located next to furnace.
  - b. Remove control box cover and locate heating relay in control box. Turn the dial counter clockwise <- to desired setting.

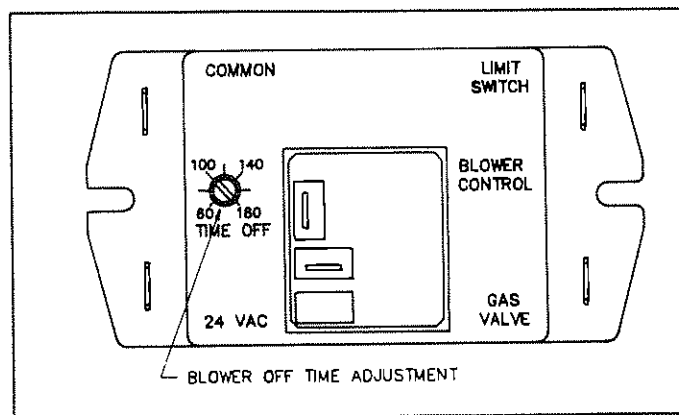

FIGURE 40

4. Install control box cover.
5. Turn on electricity at electrical disconnect switch next to furnace.

## SECTION 29 — MAINTAINING FURNACE IN GOOD WORKING ORDER.

**WARNING:** Follow these procedures before inspecting furnace.

- Turn room thermostat to its lowest or off setting.
- Turn off manual gas shut-off valve.
- Wait at least five minutes for furnace to cool if it was recently operating.
- Turn off furnace electrical power; failure to do so could result in injury or death.

**WARNING:** Use replacement parts listed in parts list. Failure to do so could cause improper furnace operation, resulting in damage, injury or death.

Perform periodic preventive maintenance once before heating season begins and once during heating season. Inspect, clean, and repair as needed following items:

1. All combustion and ventilation air openings into furnace space.
2. All burner combustion air openings.
3. All burners, pilot, collector box, draft inducer assembly and complete vent system.
4. All gas pipes leading to furnace.
5. All electrical wiring and connections, including electrical ground.
6. All supply air and return air ducts for obstructions, air leaks and loose insulation.
7. Blower housing, motor and wheel, air filters, air conditioning and draft inducer motor. Blower motor and inducer motor do not require oiling.

A qualified service technician should follow these steps to remove blower assembly.

- a. On downflow furnaces, remove vent pipe inside furnace.
- b. Disconnect wires from low voltage terminal strip on control box.
- c. Remove two screws holding control box to the side brackets.
- d. Remove blower door.
- e. Locate connector block beside blower door on control box side. Remove it by squeezing locking ears of connector block. See Figure 41.
- f. Disconnect wires to limit switches on blower housing.
- g. On dual blower wheel models, disconnect wires to door switch.

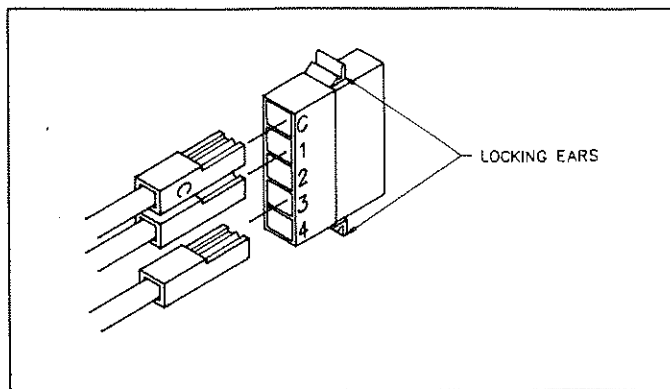

**FIGURE 41**

- h. Remove screws holding blower assembly to blower deck.
  - i. 1. Blower assembly will now slide out. DO NOT damage limit switches on bottom of blower housing.  
2. After cleaning blower assembly, reassemble in reverse order making sure speed selections are in original positions.
8. Assure the furnace is operating properly and safely.

## SECTION 30 — GETTING OTHER INFORMATION AND PUBLICATIONS.

These publications can help you install the furnace. You can usually find these at your local library or buy them directly from the publisher. Be sure to consult current edition of each standard.

National Fuel Gas Code	ANSI Z223.1/NFPA 54
National Electrical	ANSI/NFPA Code 70
Standard for the installation of Warm Air Heating and Air Conditioning Systems	ASHRAE/NFPA 90
Standard for Chimneys, Fireplaces, Vents, and Solid Fuel Burning Appliances	NFPA 211

For more information, contact these publishers:

<b>ANSI:</b>	<b>AMERICAN NATIONAL STANDARDS INSTITUTE</b> 1430 Broadway New York, NY 10018 (212) 354-3300
<b>ASHRAE:</b>	<b>AMERICAN SOCIETY OF HEATING REFRIGERATING AND AIR CONDITIONING ENGINEERS, INC.</b> 1791 Tullie Circle N.E. Atlanta, GA 30329 (404) 636-8400
<b>NFPA:</b>	<b>NATIONAL FIRE PROTECTION ASSOCIATION</b> Batterymarch Park Quincey, MA 02269 (617) 770-3000



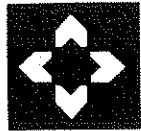

**INFORMATION**

SEE  
MANUAL NUMBER  
2100-171A  
BARD MANUFACTURING





To assure both safe and proper operation, please carefully follow the instructions in this Addendum and the basic Installers' Information Manual, number 404200, supplied with this furnace, to install this new furnace.

**ATTENTION, INSTALLER!** After installing furnace, give the user:

- Users' Information Manual; —Parts List
- Installers' Information Manual and this Addendum; — Warranty Information

**ATTENTION, USER!** Your furnace installer should give you four important documents relating to your furnace. Keep these as long as you keep your furnace. Pass these documents on to later furnace purchasers or users. If any of the four documents is missing or damaged, contact your installer or furnace manufacturer for replacement. For efficient service, please give your furnace model and serial number, listed in Section 1 of your Users' Information Manual. Throughout this Installers' Information Manual Addendum, we frequently use the word "you" when referring to the person responsible for application, installation and service of your furnace. Please remember to have only qualified service technicians perform these services.

**WARNING:** INDIVIDUALS WHO INSTALL THIS FURNACE, MUST HAVE THE TRAINING AND EXPERIENCE NECESSARY TO INSTALL HORIZONTAL GAS FURNACES. THEY MUST ALSO HAVE TRAINING AND EXPERIENCE NECESSARY TO INSTALL RELATED COMFORT AIR CONDITIONING APPLIANCES. IMPROPER INSTALLATION COULD CREATE A HAZARD, RESULTING IN DAMAGE, INJURY OR DEATH.

While we have written these instructions as accurately and thoroughly as possible, they may not cover every system variation or contingency. Also, questions or interpretation may arise. For more information, solutions to particular problems or clarification contact your local distributor. See the furnace rating plate for who to contact.

Furnace installation must follow all applicable NATIONAL, STATE and LOCAL CODES.

**WARNING:** FOR YOUR SAFETY, WHAT TO DO IF YOU SMELL GAS.

- DO NOT TRY TO LIGHT ANY APPLIANCE;
- DO NOT TOUCH ANY ELECTRICAL SWITCH; DO NOT USE ANY PHONE IN THE BUILDING;
- IMMEDIATELY CALL YOUR GAS SUPPLIER FROM A NEIGHBOR'S PHONE; FOLLOW GAS SUPPLIERS INSTRUCTIONS;
- IF YOU CANNOT REACH GAS SUPPLIER, CALL FIRE DEPARTMENT.

**IMPORTANT SAFETY NOTE:** After installing the furnace, show the user how to turn off gas and electricity to furnace. Point out control and switch locations for turning off gas and electricity. Go over Section 6 of Users' Information Manual and Section 31 of the Installers' Information Manual with user. Warn user to keep insulating materials away from furnace and combustion and ventilation air openings into furnace space. Explain to user that these openings provide fresh air to furnace, that is necessary for proper operation. Make sure user understands the importance of following all safety precautions.

## 1. HORIZONTAL VENTING

**NOTE:** This Induced Draft furnaces can be horizontally vented through an outside wall without the addition of an accessory power venter. Horizontally vented Induced Draft furnaces **must not** be common vented with any other appliance.

**WARNING: COMMON VENTING COULD ALLOW PRODUCTS OF COMBUSTION TO ESCAPE THROUGH OTHER APPLIANCE CONNECTED TO SAME VENT. THIS COULD RESULT IN COMBUSTION PRODUCTS COLLECTING IN STRUCTURE DURING USE, RESULTING IN INJURY OR DEATH.**

### A. Venting Materials

Use only high temperature plastic pipe for horizontal venting of induced draft furnaces. Allowable materials are Hart & Cooley's "Ultravent" or Plexco's "Plexvent". Install using these instructions and vent manufacturers' instructions.

**WARNING: DO NOT USE DOUBLE WALL B-VENT, SINGLE WALL C-VENT, PVC OR ANY OTHER PLASTIC VENTING MATERIALS OTHER THAN THOSE LISTED BELOW. IMPROPER VENTING MATERIALS COULD DETERIORATE ALLOWING COMBUSTION PRODUCTS TO COLLECT IN STRUCTURE DURING USE, RESULTING IN INJURY OR DEATH.**

VENT COMPONENTS			
Item Description	Hart/Cooley 3" Pipe	Plexco 3" Pipe	Plexco 4" Pipe
5 ft. Pipe Length	3UP5	901220	903851
90-Degree Sweep Elbow	3UES90	902299	905772
45-Degree Elbow	3UE45	903958	905773
Tee	3UT	905268	903854
Debris Screen	3UDS	—	—
Tee With Screen	—	901971	906882
Condensate Drain	3UDP	906646	903855
Coupling	3UC	905630	905807
4" Reducer	4UR3	905744	905744
Sealant	DOW736RTV	DOW736RTV	DOW736RTV
Drain Tee-Lateral	3UT	901761	903929
Drain Tee-Vertical	3UT	901467	903917
Wall Thimble	Note (1)	Note (1)	Note (2)
Roof Flashing	3UF	Note (3)	Note (4)
Vent Outlet Kit	—	—	4059400*

(1) Use 905295, 905662, or 906972 (2) Use 906979, 907084, 907094 or 907103  
(3) Use 905650, 906971, 905337 (4) Use 907078, 906983, 907089 or 907105

\* This kit is supplied by manufacturer and is only required on models with inputs of 120,000 or 140,000 BTUH.

## B. Planning The Installation

AIR SPACE CLEARANCES TO COMBUSTIBLE MATERIAL	
Pipe Diameter	Clearance
3"	5"
4"	9"

\* Clearances to combustible material may be reduced when combustible material is protected as described in current National Fuel Gas Code ANSI Z223.1/NFPA54, part 6 entitled "Installation of Specific Equipment", subsection entitled "Clearances for Indoor Installation".

**NOTE:** When high temperature plastic pipe is used on a furnace converted to downflow position, be aware that plastic pipe must be disconnected each time service or certain replacement parts are needed. When replacing plastic pipe after servicing or repair, follow pipe joining instructions to assure a proper seal.

**NOTE:** Do not insulate high temperature plastic pipe or fittings.

1. Maintain clearances listed above to all sections of pipe, except at wall thimble when horizontally venting.
2. Tools needed for installation are: Hacksaw - 24 teeth per inch, Level, Foil Tape, Hammer and Nails, Masonry Saw, Support Strapping and Tape Measure.
3.
  - a. Before installing vent system, be sure you have enough space to attain the required 1/4 inch rise per foot of vent run. This rise is necessary for proper vent operation and condensate drainage.
  - b. Support vent every 5 feet horizontally and at all elbows or couplings.
4. Locate vent wall penetration so that it allows a minimum of 1/4 inch rise per foot of vent run.
5.
  - a. Locate vent termination so prevailing winds will not affect its operation. When this is not possible, consider using protection from strong winds such as a fence.
  - b. Locate vent termination following the minimum clearances listed below and see Figure 1.
    1. At least 12 inches above grade level or above normal snow accumulation level.
    2. At least 4 feet below, 4 feet horizontally from or 1 foot above any door, window or gravity air inlet to the building.
    3. At least 4 feet horizontally from and not above any public walkways, regulators, relief valves or gas and electric meters.



4. At least 6 feet from any inside corner formed by two exterior walls. 10 feet is desirable.
5. At least 4 feet horizontally and vertically from any soffit or under eave vent.
6. At least 3 feet above or 10 feet from any forced air inlet to the building.
7. At least 10 feet from any adjacent building.
8. At least 4 feet from plants or shrubbery.

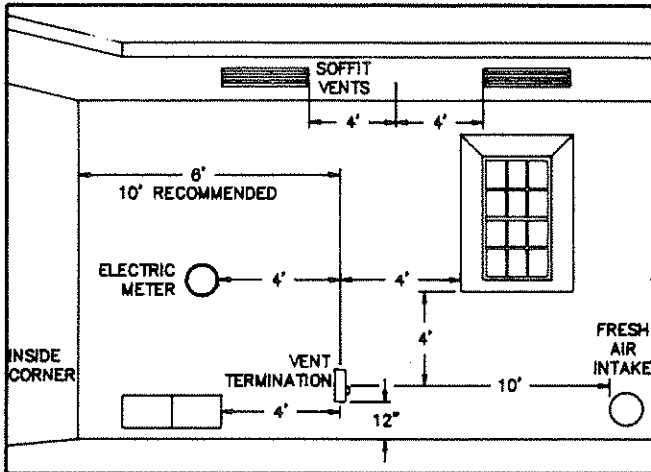

Figure 1

6. See below for allowable vent lengths and vent pipe sizes.

**Furnace**

Input BTUH	Vent Pipe Size	Maximum Lengths & Elbows
40,000	3 inch	40 ft. & 4 elbows
60,000	4 inch	40 ft. & 4 elbows
80,000	4 inch	40 ft. & 4 elbows
100,000	4 inch	40 ft. & 4 elbows
120,000	4 inch	40 ft. & 4 elbows
140,000	4 inch	40 ft. & 4 elbows

**NOTE:** A minimum vent length of 48 inches is necessary for furnace service access.

**C. Vent Pipe Installation**

1. Cutting

Cut pipe with a handsaw containing at least 24 teeth per inch. Cut pipe squarely.

**WARNING:** FAILURE TO CUT PIPE SQUARELY COULD RESULT IN PIPE NOT SEALING PROPERLY. THIS COULD ALLOW

**COMBUSTION PRODUCTS TO COLLECT IN STRUCTURE DURING USE, RESULTING IN INJURY OR DEATH.**

**WARNING:** DO NOT DRILL HOLES IN PLASTIC PIPE OR FITTINGS. DO NOT USE SHEET METAL SCREWS, RIVETS OR LOCKING CLIPS IN PIPE OR FITTINGS. DRILLING, USING SCREWS OR RIVETS MAY CAUSE PIPE OR FITTINGS TO CRACK, ALLOWING COMBUSTION PRODUCTS TO COLLECT IN STRUCTURE DURING USE, RESULTING IN INJURY OR DEATH.

**NOTE:** Do not cut pipe with a power saw. Cutting pipe with a power saw may cause cracking or shattering of pipe. Cracking or shattering pipe may prevent a complete seal when joining pipe.

2. Joining and Sealant

Use only approved sealant, Dow-Corning RTV-736.

**WARNING:** USE ONLY APPROVED SEALANT, DO NOT USE PVC CEMENT. FAILURE TO SEAL VENT SYSTEM WITH PROPER SEALANT AND PROCEDURE COULD ALLOW COMBUSTION PRODUCTS TO COLLECT IN STRUCTURE DURING USE, RESULTING IN INJURY OR DEATH.

**NOTE:** Be sure pipe and fitting surfaces are clean and free of any oils, greases or dirt that could adversely affect the pipe seal.

- a. Apply a 1/4 inch thick bead of approved sealant within 1/8 inch of male pipe end. Apply entirely around outside of male pipe.
- b. Push pipe and fitting completely together in a twisting motion to help spread sealant.
- c. When pipe seats in the fitting, check that a complete ring of sealant is visible. A complete ring of sealant assures seal is gas-tight. Sealant cures in 24 hours. Use foil tape to hold joints together until cured, remove tape after sealant cures.

**NOTE:** Vent system can be used before sealant cures.

3. Vent Outlet Kit (4059400)

You must use vent outlet kit part number 4059400 when using high temperature plastic pipe on models with inputs of 120,000 and 140,000 Btuh. Vent outlet kit 4059400 is **only** required on models with inputs of 120,000 and 140,000 Btuh.

Vent outlet kit is required to convert oval vent collar to round vent collar. Round vent collar will make furnace compatible for use with 4 inch diameter, high temperature plastic pipe.

#### 4. Condensate Disposal

Vent system must contain a tee with drain plug and means of disposing of condensate. The drain tee must be within the first 18 inches of vent run to prevent furnace condensate and rain from draining back into furnace.

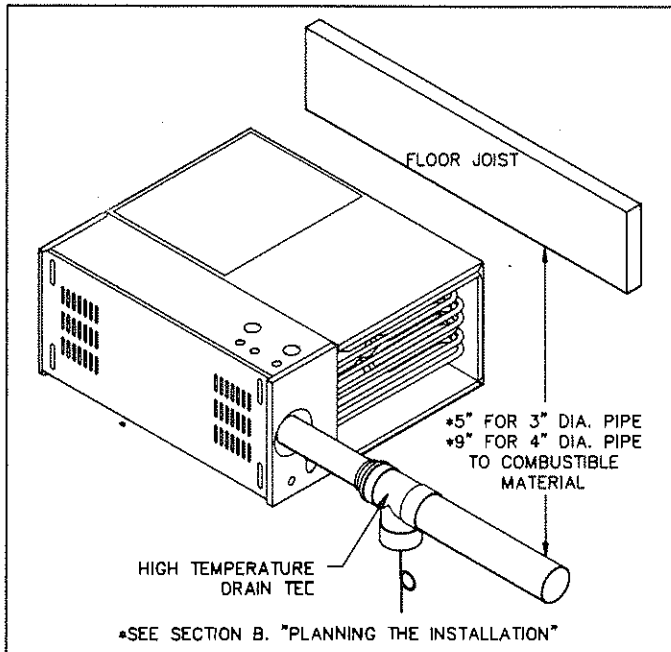

Figure 2

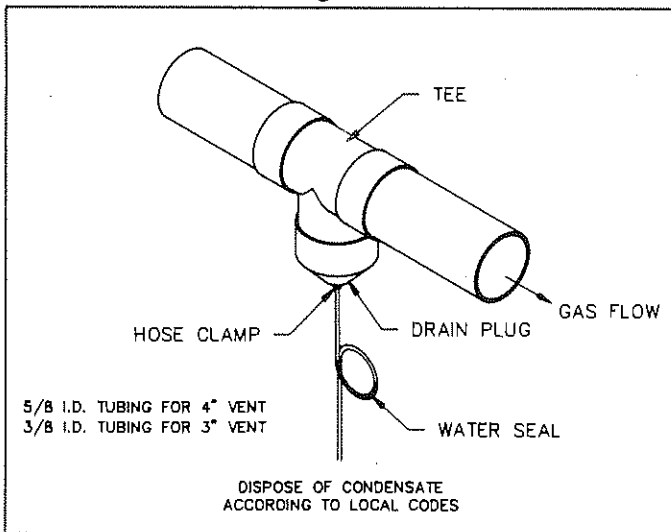

Figure 3

Attach correct size flexible vinyl drain tubing to drain plug. Fill the drain tube trap with a water seal. This will prevent combustion products from escaping through the flexible vinyl drain tube. See Figure 3.

**WARNING:** FAILURE TO FILL FLEXIBLE VINYL DRAIN TUBE TRAP WITH A WATER SEAL COULD ALLOW COMBUSTION PRODUCTS TO COLLECT IN STRUCTURE DURING USE, RESULTING IN INJURY OR DEATH.

**NOTE:** If flexible vinyl drain tube is in an area that may expose condensate to below freezing temperatures, use heat tapes. Use heat tapes that will not melt condensate tubing material.

#### 5. Wall Penetration

a. When penetrating a non-combustible wall, make the hole just large enough for vent pipe. Use approved sealant material to seal vent pipe to the non-combustible wall. See Figure 4.

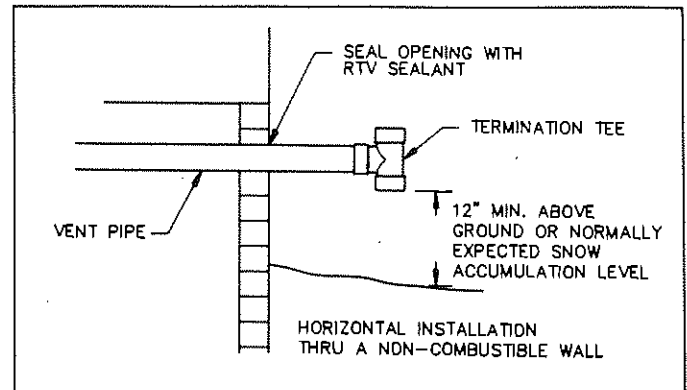

Figure 4

b. When penetrating a combustible wall, you must use a listed wall thimble. All thimbles are adjustable to fit variable wall thicknesses and are listed in the parts list on page 2.

**WARNING:** FAILURE TO USE A WALL THIMBLE COULD CAUSE COMBUSTIBLE WALL MATERIAL TO IGNITE RESULTING IN DAMAGE, INJURY OR DEATH.

**NOTE:** Use Figure 5 in conjunction with instructions below to properly install wall thimble.

1. Cut an 8 1/2 inch diameter round hole in wall. Locate it where you can maintain the necessary 1/4 inch per foot rise in the vent system.
2. Hold thimble in place by applying approved sealant to male half before assembling. Insert thimble into wall.
3. After inserting thimble, secure to outside and inside walls with nails or screws. Seal thimble to inner and outer walls with approved sealant material.
4. Insert a section of vent pipe through thimble that leaves at least 14 inches of vent pipe protruding from thimble.
5. To prevent vent pipe from moving in thimble, attach stainless steel hose clamp to both pipe ends extending from thimble. See Figure 5.

## D. Vent Termination Tee Installation

Use only a termination tee with debris screen for vent termination. See below for allowable termination tees.

Item Description	Hart/Coolay	Plexco	Plexco
	3" Pipe	3" Pipe	4" Pipe
Termination Tee	3UT	—	—
Debris Screen	3UDS	—	—
Termination Tee with			
Debris Screen	—	901971	906882

**Caution:** Do not locate the vent termination closer than 4 feet to plants or shrubbery as combustion products may stunt or kill them. Also see section B for proper vent termination tee clearances.

**Caution:** In some instances, excessive condensate at the termination tee can cause staining or damage to the outside wall. Sealing or shielding of outside wall with a corrosion resistant material (such as aluminum sheet) may be necessary.

### 1. Installing Termination Tee

- Use approved sealant to join termination tee to section of vent pipe protruding from thimble. Termination tee must be in vertical position. See Figure 5.
- Make sure debris screens are in place.
- The inside of the termination tee must be a minimum of 14 inches from outside wall. See Figure 5 for a correctly completed installation.

**Caution:** Do not step on, sit or place any weight on termination tee. If termination tee is dislodged, furnace may not operate.

**WARNING:** DO NOT STEP ON, HIT OR PLACE ANY WEIGHT ON TERMINATION TEE. IF TERMINATION TEE IS MISHANDLED, VENT SYSTEM MAY BECOME DISCONNECTED AT FURNACE ALLOWING FLUE PRODUCTS TO COLLECT IN STRUCTURE DURING USE, RESULTING IN INJURY OR DEATH.

## 2. VERTICAL VENTING

When using high temperature plastic pipe, vent system must be dedicated and is not to be common vented with any other appliance.

**WARNING:** COMMON VENTING COULD ALLOW PRODUCTS OF COMBUSTION TO ESCAPE THROUGH OTHER APPLIANCE CONNECTED TO SAME VENT. THIS COULD RESULT IN COMBUSTION PRODUCTS COLLECTING IN STRUCTURE DURING USE, RESULTING IN INJURY OR DEATH.

### A. Starting Vent System

You may use high temperature plastic pipe to vertically vent this induced-draft furnace. Use instructions in horizontal venting section for proper air space clearances to combustible materials, pipe sizing, allowable runs, joining, cutting, condensate disposal, inducer transition, and plastic vent transition kit. See Figures 6 and 7 for correctly started vertical vent systems.

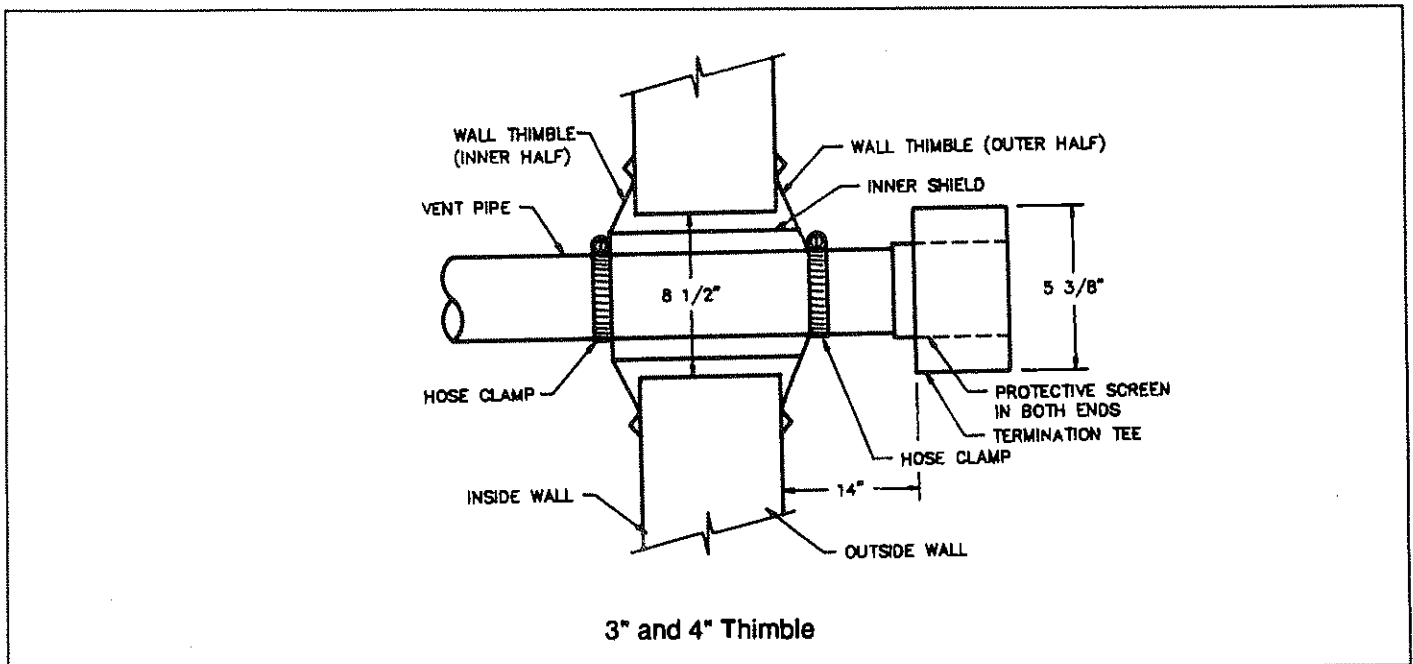

Figure 6  
67



# SIDEWALL VENTING

# INFORMATION

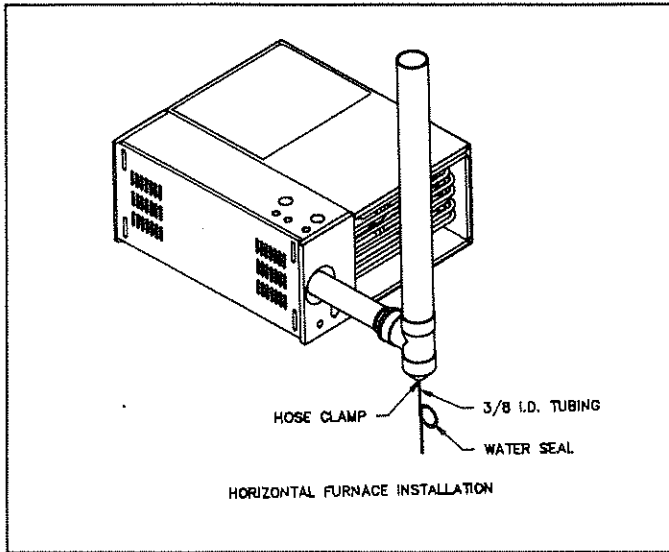

Figure 6

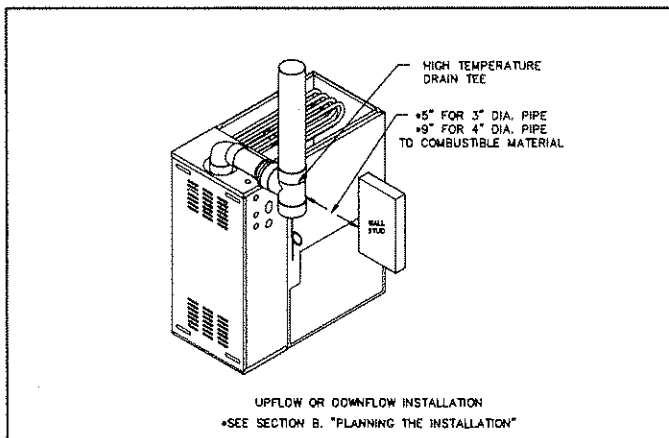

Figure 7

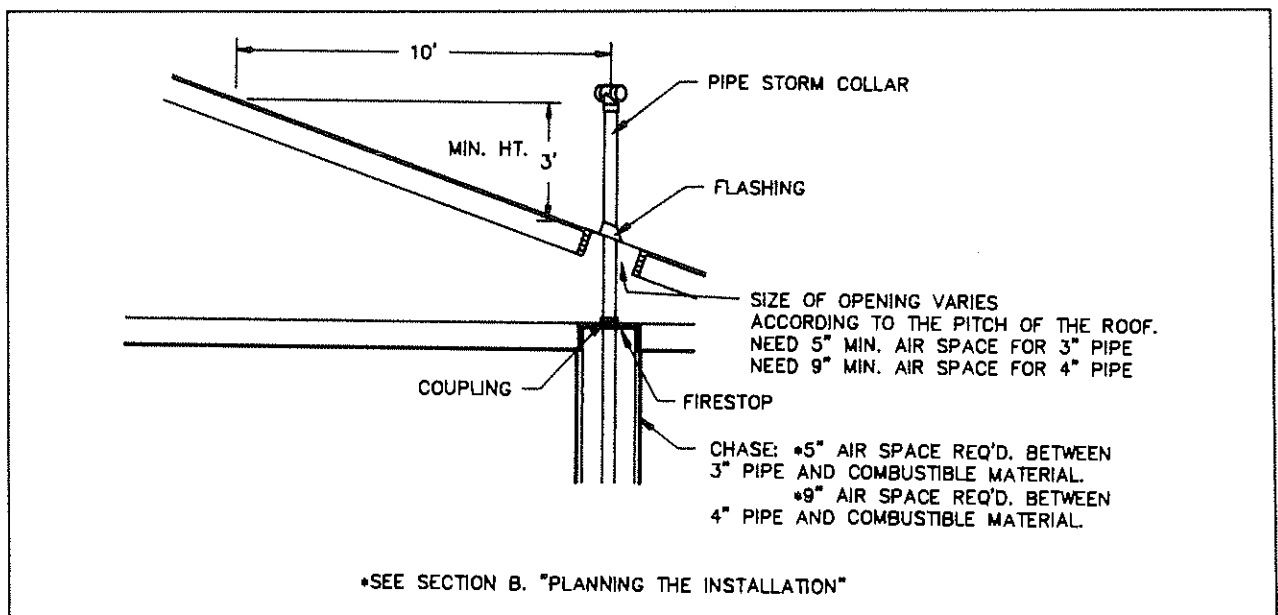

Figure 8

## B. Vent Termination

Only a termination tee with debris screen is allowed for vent termination. See Section D., Vent Termination Tee Installation for allowable termination tee.

**NOTE:** Terminating vent system with other than terminating tee can cause improper furnace operation. See Figure 8 for proper vertical vent termination.

Vent this furnace using these instructions, Installers' Information Manual and Part 7 of Current National Fuel Gas Code ANSI Z223.1/NFPA 54. Also, meet requirements of local utilities and other local code authorities.