

INSTALLATION INSTRUCTIONS

WALL MOUNTED PACKAGE HEAT PUMPS

MODELS

WH421

WH481

WH601

MANUAL 2100-219 REV. A
SUPERSEDES REV.
FILE VOL. III, TAB 17

SECTION 1 --GETTING OTHER INFORMATION AND PUBLICATIONS

These publications can help you install the air conditioner or heat pump. You can usually find these at your local library or purchase them directly from the publisher. Be sure to consult current edition of each standard.

National Electrical Code	-ANSI/NFPA 70
Standard For The Installation Of Air Conditioning and Ventilating Systems	-ANSI/NFPA 90A
Standard For Warm Air Heating and Air Conditioning Systems	-ANSI/NFPA 90B
Load Calculation For Residential Winter and Summer Air Conditioning	-ACCA Manual J
Duct Design For Residential Winter and Summer Air Conditioning and Equipment Selection	-ACCA Manual D

FOR MORE INFORMATION, CONTACT THESE PUBLISHERS

ACCA:	AIR CONDITIONING CONTRACTORS OF AMERICA 1513 16th Street NW Washington, DC 20036 Telephone: (202) 483-9370	Fax: (202) 234-4721
ANSI:	AMERICAN NATIONAL STANDARDS INSTITUTE 11 West Street, 13th Floor New York, NY 10036 Telephone: (212) 642-4900	Fax: (212) 302-1286
ASHRAE:	AMERICAN SOCIETY OF HEATING REFRIGERATING AND AIR CONDITIONING ENGINEERS, INCORPORATED 1791 Tullie Circle, N.E. Atlanta, GA 30329-2305 Telephone: (404) 636-8400	Fax: (404) 321-5478
NFPA:	NATIONAL FIRE PROTECTION ASSOCIATION Batterymarch Park P. O. Box 9101 Quincy, MA 02269-9901 Telephone: (800) 344-3555	Fax: (617) 984-7057

TABLE OF CONTENTS

PART 1 -- WALL MOUNT--GENERAL INSTALLATION INFORMATION

Heat Pump Wall Mount Model Nomenclature	1
Shipping Damage	1
General	4
Duct Work	4
Filters	5
Fresh Air Intake	5
Condensate Drain	5

PART 2 -- INSTALLATION

Wall Mounting Information	5
Mounting The Unit	5

WIRING

Wiring--Main Power	9
Wiring: Low Voltage Wiring	9

THERMOSTAT WIRING

Compressor Cut-Off Thermostat and Outdoor Thermostats	10
Compressor Cut-Off and Outdoor Thermostat Wiring	10
Heat Anticipation	11
Thermostat Indicator Lamps	11
Emergency Heat Position	11
Compressor Malfunction Light	11

PART 3 -- START-UP

Important Installer Note	12
Crankcase Heaters	12
Service Hints	12
Sequence of Operation	13
Pressure Service Ports	13
Defrost Cycle	13

PART 4 -- TROUBLESHOOTING

Solid State Heat Pump Control Troubleshooting Procedure	15
Checking Temperature Sensor Outside Unit Circuit	16
Fan Blade Setting Dimensions	17
Removal of The Fan Shroud	17
Refrigerant Charge	18
Pressure Tables	19
Optional Accessories.	20

PART 1 -- WALL MOUNT GENERAL INFORMATION

HEAT PUMP WALL MOUNT MODEL NOMENCLATURE

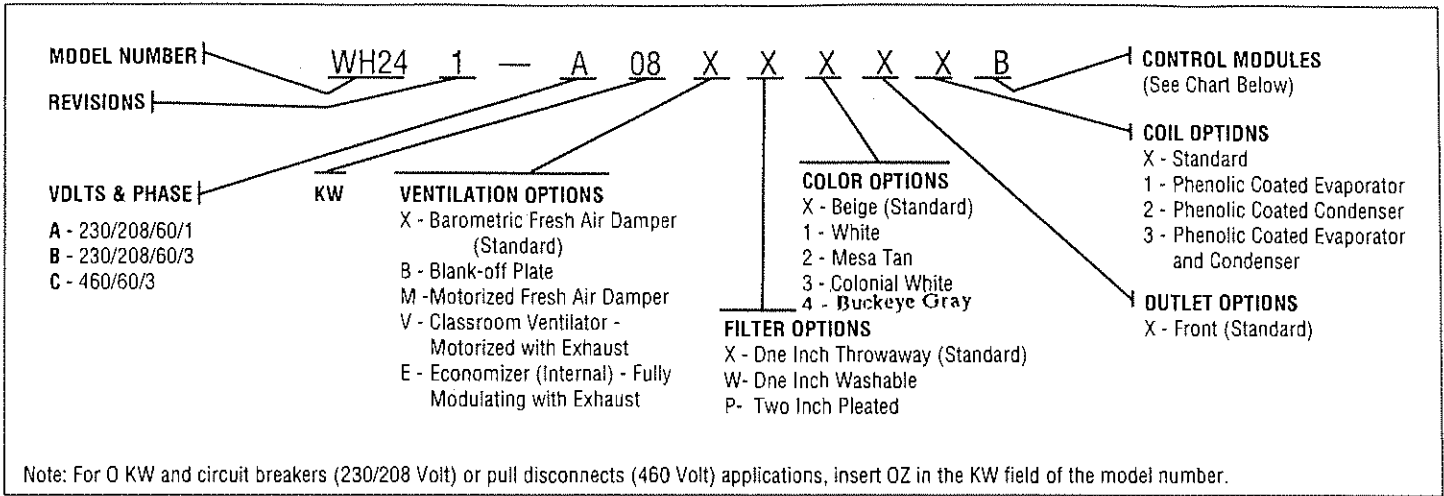

TABLE 1

ELECTRIC HEAT TABLE

Models	WH421-A		WH421-B				WH421-C		WH481-A WH601-A		WH481-B WH601-B				WH481-C WH601-C					
	240-1		208-1		240-3		208-3		460-3		240-1		208-1		460-3					
	KW	A	BTU	A	BTU	A	BTU	A	BTU	A	BTU	A	BTU	A	BTU	A	BTU			
5	20.8	17065	18.1	12800					20.8	17065	18.1	12800								
9					14.4	20500	12.5	15360	7.2	20475					14.4	20500	12.5	15360	7.2	20475
10	41.6	34130	36.2	25600					41.6	34130	36.2	25600								
15	62.5	51200	54.1	38400	36.2	51200	31.2	38400	18.0	51200	62.5	51200	54.1	38400	36.2	51200	31.2	38400	18.0	51200
18															43.3	61400	37.5	46050		
20											83.2	68250	72.1	51200						

SHIPPING DAMAGE

Upon receipt of equipment, the carton should be checked for external signs of shipping damage. If damage is found, the receiving party must contact the last carrier immediately, preferably in writing, requesting inspection by the carrier's agent.

FIGURE 1
 SIZE SPECS FOR MIS-411

UNIT	WIDTH (W)	DEPTH (D)	HEIGHT (H)	SUPPLY			RETURN			E	F	G	I	J	K	L	M	N	O	P	Q
				A	B	C	B	C													
42 & 60	42	22-1/4	84-7/8	9-7/8	29-7/8	15-7/8	29-7/8	43-7/8	19	31-5/8	30	32-11/16	27	34-3/4	32-1/2	3-1/4	43	23-7/8	10		

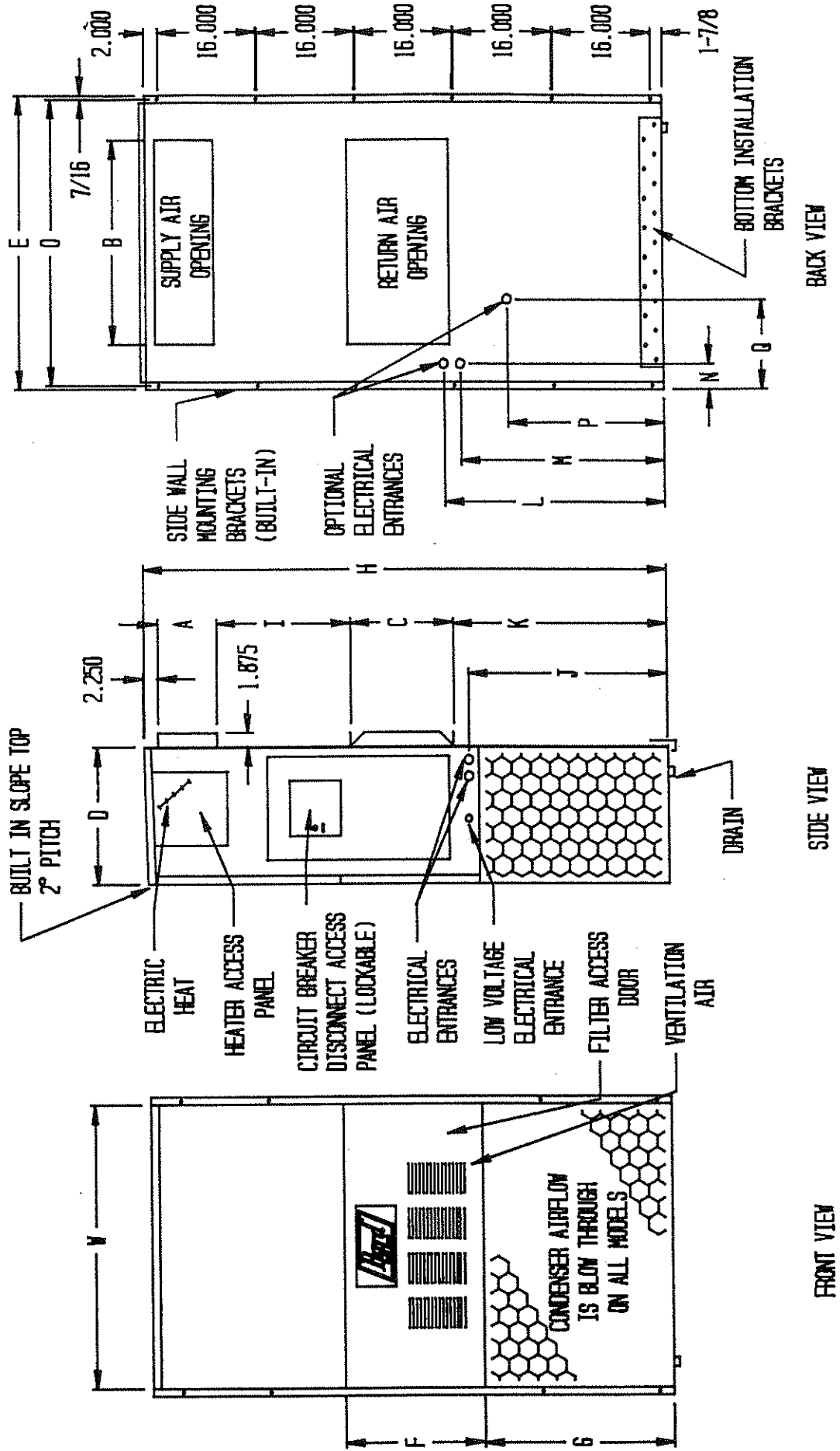

TABLE 2

ELECTRICAL SPECIFICATIONS

SINGLE CIRCUIT							DUAL CIRCUIT							
Model	Rated Volts and Phase	No. Field Power Ckts.	(4) Minimum Circuit Ampacity	(1) Maximum External Fuse Or Circuit Breaker	(2) Field Power Wire Size	(2) Ground Wire Size	(4) Minimum Circuit Ampacity		(1) Maximum External Fuse Or Ckt. Breaker		(2) Field Power Wire Size		(2) Ground Wire Size	
							Ckt A	Ckt B	Ckt A	Ckt B	Ckt A	Ckt B	Ckt A	Ckt B
WH421-A00,A0Z A05 (3) A10 A15	230/208-1	1	32	50	8	10	N/A	N/A	N/A	N/A	N/A	N/A	N/A	N/A
		1 or 2	58	70	6	8	33	26	50	30	8	10	10	10
		1 or 2	84	90	4	8	33	52	50	60	8	6	10	10
		1 or 2	84	90	4	8	33	52	50	60	8	6	10	10
WH421-B00,BOZ (3) B09 B15	230/208-3	1	24	35	10	10	N/A	N/A	N/A	N/A	N/A	N/A	N/A	N/A
		1	51	60	6	10	N/A	N/A	N/A	N/A	N/A	N/A	N/A	N/A
		1	51	60	6	10	N/A	N/A	N/A	N/A	N/A	N/A	N/A	N/A
WH421-C00,COZ (3) C09 C15	460-3	1	12	15	14	14	N/A	N/A	N/A	N/A	N/A	N/A	N/A	N/A
		1	25	30	10	10	N/A	N/A	N/A	N/A	N/A	N/A	N/A	N/A
		1	25	30	10	10	N/A	N/A	N/A	N/A	N/A	N/A	N/A	N/A
WH481-A00,A0Z A05 (3) A10 A15 A20	230/208-1	1	36	50	8	10	N/A	N/A	N/A	N/A	N/A	N/A	N/A	N/A
		1 or 2	61	80	6	8	39	26	50	30	8	10	10	10
		1 or 2	87	100	3	8	39	52	50	60	8	6	10	10
		1 or 2	87	100	3	8	39	52	50	60	8	6	10	10
		1 or 2	108	110	2	6	56	52	60	60	6	6	10	10
WH481-B00,BOZ (3) B09 B15 B18	230/208-3	1	25	35	8	10	N/A	N/A	N/A	N/A	N/A	N/A	N/A	N/A
		1	52	60	6	10	N/A	N/A	N/A	N/A	N/A	N/A	N/A	N/A
		1	52	60	6	10	N/A	N/A	N/A	N/A	N/A	N/A	N/A	N/A
		1	58	60	6	10	N/A	N/A	N/A	N/A	N/A	N/A	N/A	N/A
WH481-C00,COZ (3) C09 C15	460-3	1	14	20	12	12	N/A	N/A	N/A	N/A	N/A	N/A	N/A	N/A
		1	27	30	10	10	N/A	N/A	N/A	N/A	N/A	N/A	N/A	N/A
		1	27	30	10	10	N/A	N/A	N/A	N/A	N/A	N/A	N/A	N/A
WH601-A00,A0Z A05 (3) A10 A15 A20	230/208-1	1	43	60	8	10	N/A	N/A	N/A	N/A	N/A	N/A	N/A	N/A
		1 or 2	69	90	4	8	43	26	60	60	8	10	10	10
		1 or 2	95	110	3	6	43	52	60	60	8	6	10	10
		1 or 2	95	110	3	6	43	52	60	60	8	6	10	10
		1 or 2	108	110	2	6	56	52	60	60	6	6	10	10
WH601-B00,BOZ (3) B09 B15 B18	230/208-3	1	31	45	8	10	N/A	N/A	N/A	N/A	N/A	N/A	N/A	N/A
		1	58	60	6	10	N/A	N/A	N/A	N/A	N/A	N/A	N/A	N/A
		1	58	60	6	10	N/A	N/A	N/A	N/A	N/A	N/A	N/A	N/A
		1	59	60	6	10	N/A	N/A	N/A	N/A	N/A	N/A	N/A	N/A
WH601-C00,COZ (3) C09 C15	460-3	1	15	20	12	12	N/A	N/A	N/A	N/A	N/A	N/A	N/A	N/A
		1	28	30	10	10	N/A	N/A	N/A	N/A	N/A	N/A	N/A	N/A
		1	28	30	10	10	N/A	N/A	N/A	N/A	N/A	N/A	N/A	N/A

- (1) Maximum size of the time delay fuse or HACR type circuit breaker for protection of field wiring conductors.
- (2) Based on 75°C copper wire. All wiring must conform to NEC and all local codes.
- (3) Maximum KW that can operate with heat pump on.
- (4) These "Minimum Circuit Ampacity" values are to be used for sizing the field power conductors. Refer to the National Electric Code (latest revision), article 310 for power conductor sizing. Caution: When more than one field power conductor circuit is run thru one conduit, the conductors must be derated. Pay special attention to note 8 of table 310 regarding Ampacity Adjustment Factors when more than 3 conductors are in a raceway.

GENERAL

The equipment covered in this manual is to be installed by trained, experienced service and installation technicians.

The refrigerant system is completely assembled and charged. All internal wiring is complete.

The unit is designed for use with or without duct work. Flanges are provided for attaching the supply and return ducts.

These instructions explain the recommended method to install the air cooled self-contained unit and the electrical wiring connections to the unit.

These instructions and any instructions packaged with any separate equipment required to make up the entire air conditioning system should be carefully read before beginning the installation. Note particularly "Starting Procedure" and any tags and/or labels attached to the equipment.

While these instructions are intended as a general recommended guide, they do not supersede any national and/or local codes in any way. Authorities having jurisdiction should be consulted before the installation is made. See Page 1 for information on codes and standards.

Size of unit for a proposed installation should be based on heat loss calculation made according to methods of Air Conditioning Contractors of America (ACCA). The air duct should be installed in accordance with the Standards of the National Fire Protection Association for the Installation of Air Conditioning and Ventilating systems of Other Than Residence Type, NFPA No. 90A, and Residence Type Warm Air Heating and Air Conditioning Systems, NFPA No. 90B. Where local regulations are at a variance with instructions, installer should adhere to local codes.

DUCT WORK

Any heat pump is more critical of proper operating charge and an adequate duct system than a straight air conditioning unit. All duct work, supply and return, must be properly sized for the design air flow requirement of the equipment. Air Conditioning Contractors of America (ACCA) is an excellent guide to proper sizing. All duct work or portions thereof not in the conditioned space should be properly insulated in order to both conserve energy and prevent condensation or moisture damage.

Refer to Table 10 for maximum static pressure available for duct design.

Design the duct work according to methods given by the Air Conditioning Contractors of America (ACCA). When duct runs through unheated spaces, it should be insulated with a minimum of one inch of insulation. Use insulation with a vapor barrier on the outside of the insulation. Flexible joints should be used to connect the duct work to the equipment in order to keep the noise transmission to a minimum.

A 1/4-inch clearance to combustible material for the first three feet of duct attached to the outlet air frame is required. See Pages 5, 6 and 7 Wall Mounting Instructions and Figures 2 and 2A for further details.

Ducts through the walls must be insulated and all joints taped or sealed to prevent air or moisture entering the wall cavity.

Some installations may not require any return air duct. It is recommended that on this type of installation that a filter grille be located in the wall. Filters must be of sufficient size to allow a maximum velocity of 400 FPM.

NOTE: If no return air duct is used, applicable installation codes may limit this cabinet to installation only in a single story structure.

FILTERS

A 1-inch throwaway filter is supplied with each unit. The filter slides into position making it easy to service. This filter can be serviced from the outside by removing the service door. A 1-inch washable filter and 2-inch pleated filter are also available as optional accessories. The internal filter brackets are adjustable to accommodate the 2-inch filter by loosening 2 screws in each bracket assembly and sliding the brackets apart to the required width and retightening the 4 screws.

FRESH AIR INTAKE

All units are built with a fresh air inlet slots punched in the service panel.

The fresh air damper assembly is standard equipment with the unit because of the variety of state or local codes requiring fresh air capability. It is shipped already attached to each unit.

All capacity, efficiency and cost of operation information as required for Department of Energy "Energyguide" Fact Sheets is based upon the fresh air blank-off plate in place and is recommended for maximum energy efficiency.

The blank-off plate is available upon request from the factory and is installed in place of the fresh air damper shipped with each unit.

CONDENSATE DRAIN

A plastic drain hose extends from the drain pan at the top of the unit down to the unit base. There are openings in the unit base for the drain hose to pass through. In the event the drain hose is connected to a drain system of some type, it must be an open or vented type system to assure proper drainage.

PART 2 -- INSTALLATION INSTRUCTIONS

WALL MOUNTING INFORMATION

1. Two holes, for the supply and return air openings, must be cut through the wall as shown in Figure 2.
2. On wood-frame walls, the wall construction must be strong and rigid enough to carry the weight of the unit without transmitting any unit vibration. **WARNING:** Fire hazard can result if 1/4-inch clearance to combustible materials for supply air duct is not maintained. See Figure 2.
3. Concrete block walls must be thoroughly inspected to insure that they are capable of carrying the weight of the installing unit.

MOUNTING THE UNIT

1. These units are secured by wall mounting brackets which secure the unit to the outside wall surface at both sides. A bottom mounting bracket is provided for ease of installation, but is not required.
2. The unit itself is suitable for "0" inch clearance, but the supply air duct flange and the first three feet of supply air duct require a minimum of 1/4-inch clearance to combustible material. If a combustible wall, use a minimum of 30-1/2" x 10-1/2" dimensions for sizing. However, it is generally recommended that a 1" clearance is used for ease of installation and maintaining the required clearance to combustible material. The supply air opening would then be 32" x 12". See Figures 2 and 2A for details.

WARNING: Failure to provide the 1/4-inch clearance between the supply duct and a combustible surface for the first three feet of duct can result in fire.

3. Locate and mark lag bolt locations and bottom mounting bracket location. See Figure 2.
4. Mount bottom mounting bracket.
5. Hook top rain flashing under back bend of top. Top rain flashing is shipped with unit, attached to back of unit on the right side.
6. Position unit in opening and secure with 5/16 lag bolts; use 3/4 inch diameter flat washers on the lag bolts.
7. Secure rain flashing to wall and caulk across entire length of top. See Figure 7.
8. For additional mounting rigidity, the return air and supply air frames or collars can be drilled and screwed or welded to the structural wall itself (depending upon wall construction). Be sure to observe required clearance if combustible wall.
9. On side by side installations, maintain a minimum of 20 inches clearance on right side to allow access to control panel and heat strips and allow proper airflow to the outdoor coil.

FIGURE 2
MOUNTING INSTRUCTIONS

	A	B	C	D	E
REQUIRED DIMENSIONS TO MAINTAIN 1/4" MIN. CLEARANCE FROM COMBUSTIBLE MATERIALS	30 1/2	10 1/2	6 1/4	1 5/16	29 1/2
REQUIRED DIMENSIONS TO MAINTAIN RECOMMENDED 1" CLEARANCE FROM COMBUSTIBLE MATERIALS	32	12	5 1/2	9/16	28

NOTE: IT IS RECOMMENDED THAT A BEAD OF SILICONE CAULKING BE PLACED BEHIND THE SIDE MOUNTING FLANGES AND UNDER THE TOP FLASHING AT TIME OF INSTALLATION.

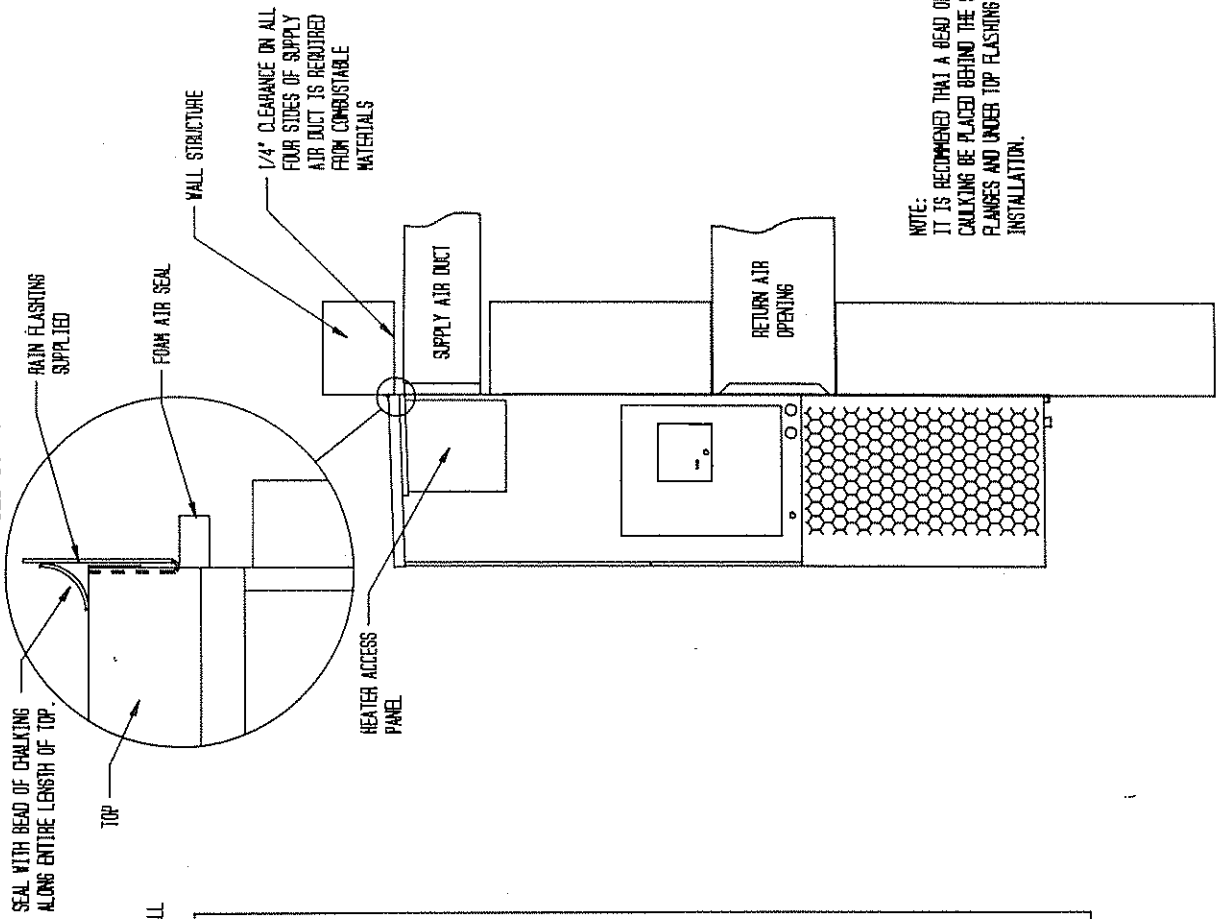

NOTE: IT IS RECOMMENDED THAT A BEAD OF SILICONE CAULKING BE PLACED BEHIND THE SIDE MOUNTING FLANGES AND UNDER TOP FLASHING AT TIME OF INSTALLATION.

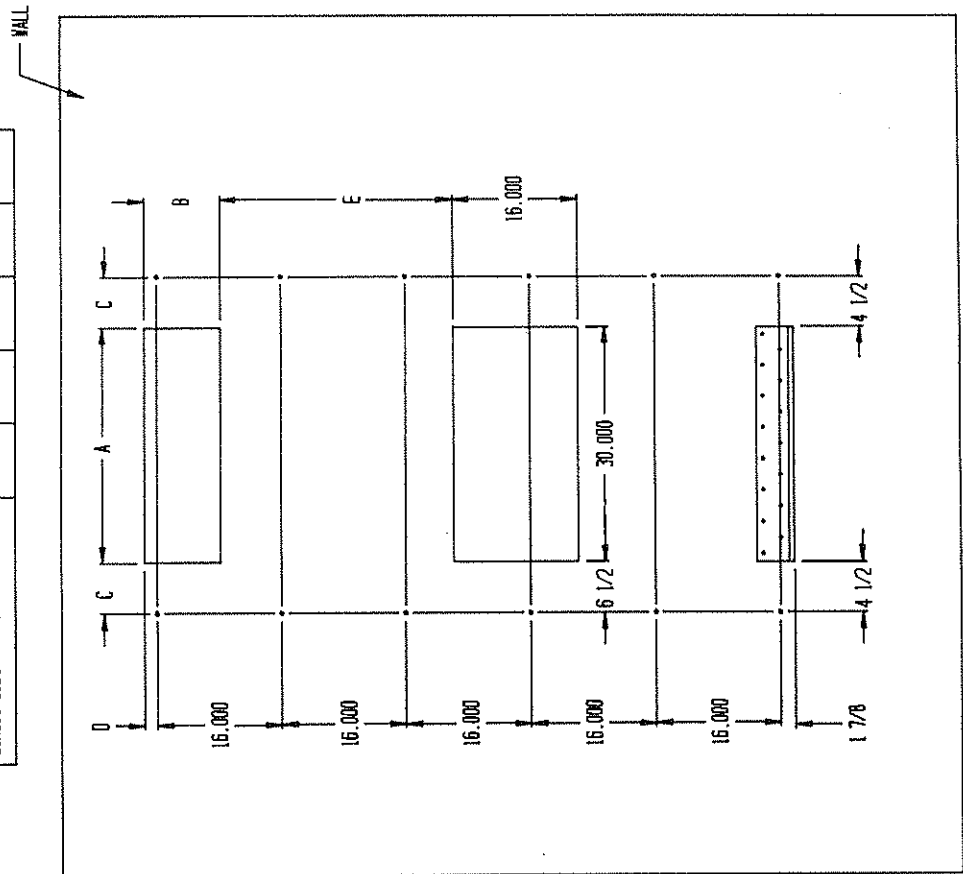
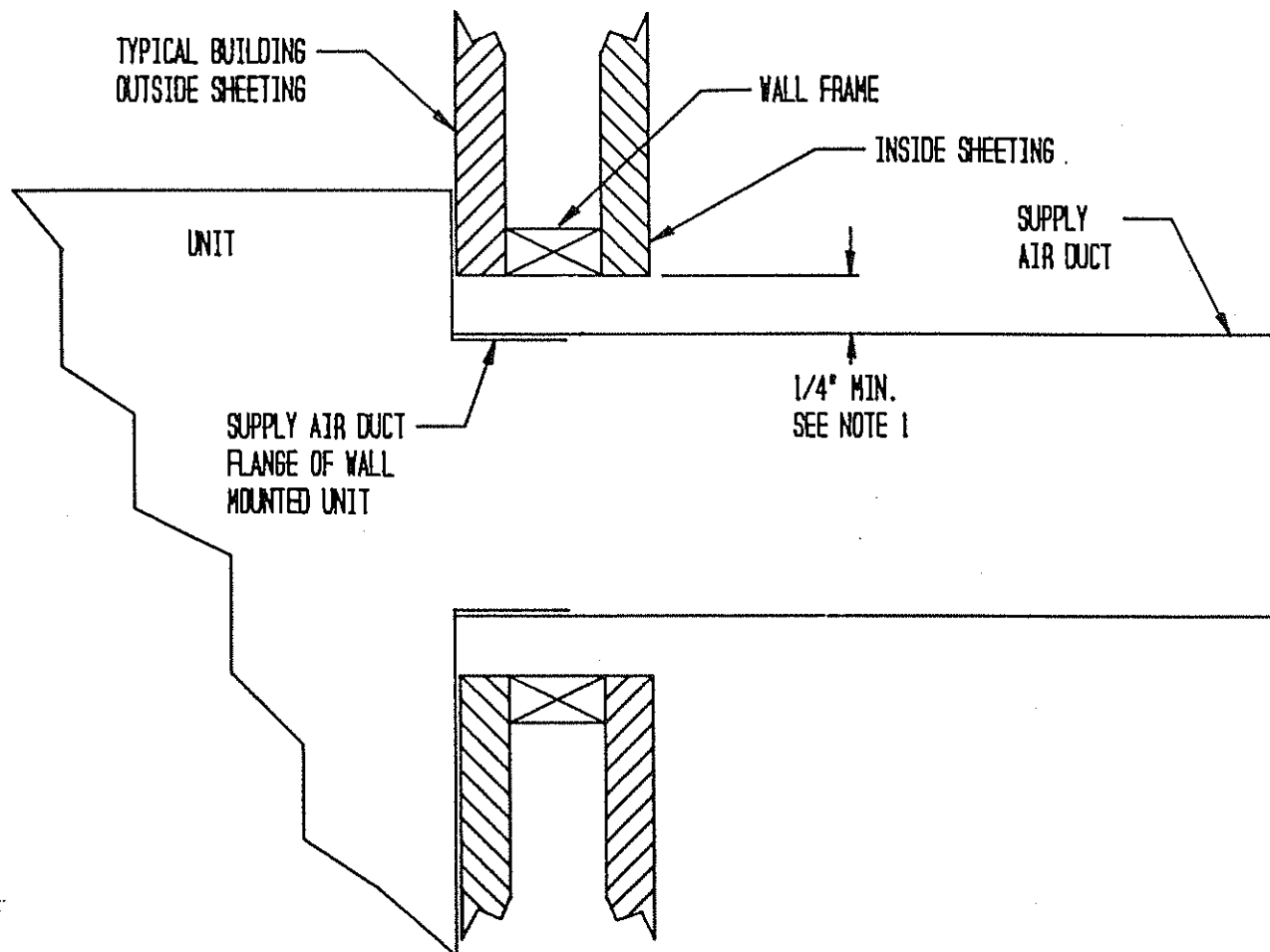

FIGURE 2A
ELECTRIC HEAT CLEARANCE



Side section view of supply air duct for wall mounted unit showing 1/4" clearance to combustible surfaces.

NOTE 1:

WARNING

A minimum of 1/4" clearance must be maintained between the supply air duct and combustible materials. This is required for the first 3 feet of ducting.

It is important to insure that the 1/4" minimum spacing is maintained at all points.

Failure to do this could result in overheating the combustible material and may result in a fire.

WIRING--MAIN POWER

Refer to the unit rating plate for wire sizing information and maximum fuse or "HACR Type" circuit breaker size. Each outdoor unit is marked with a "Minimum Circuit Ampacity". This means that the field wiring used must be sized to carry that amount of current. Depending on the installed KW of electric heat, there may be two field power circuits required. If this is the case, the unit serial plate will so indicate. All models are suitable only for connection with copper wire. Each unit and/or wiring diagram will be marked "Use Copper Conductors Only". These instructions MUST BE adhered to. Refer to the National Electrical Code (NEC) for complete current carrying capacity data on the various insulation grades of wiring material. All wiring must conform to NEC and all local codes.

The electrical data lists fuse and wire sizes (75°C copper) for all models, including the most commonly used heater sizes. Also shown are the number of field power circuits required for the various models with heaters.

The unit rating plate lists a "Maximum Time Delay Relay Fuse" or "HACR Type" circuit breaker that is to be used with the equipment. The correct size must be used for proper circuit protection and also to assure that there will be no nuisance tripping due to the momentary high starting current of the compressor motor.

The disconnect access door on this unit may be locked to prevent unauthorized access to the disconnect. To convert for the locking capability, bend the tab located in the bottom left hand corner of the disconnect opening under the disconnect access panel straight out. This tab will now line up with the slot in the door. When shut, a padlock may be placed through the hole in the tab preventing entry.

WIRING: LOW VOLTAGE WIRING

230/208V, 1 phase and 3 phase equipment dual primary voltage transformers. All equipment leaves the factory wired on 240V tap. For 208V operation, reconnect from 240V to 208V tap. The acceptable operating voltage range for the 240 and 208V taps are:

TAP	RANGE
240	253 - 216
208	220 - 187

NOTE: The voltage should be measured at the field power connection point in the unit and while the unit is operating at full load (maximum amperage operating condition).

Nine (9) wires should be run from thermostat subbase to the 24V terminal board in the unit. A nine conductor, 18 gauge copper, color-coded thermostat cable is recommended. The connection points are shown below:

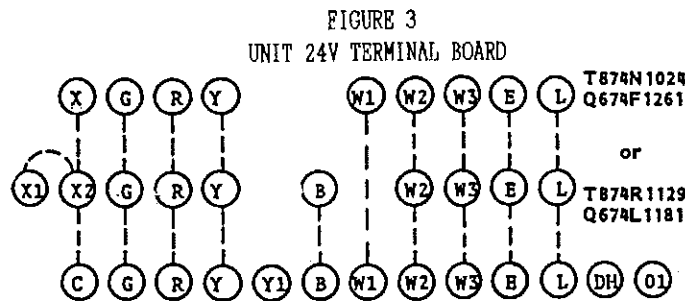

IMPORTANT NOTE: Only the thermostat and subbase combinations as shown above will work with this equipment. The thermostat and subbase MUST be matched, and the correct operation can be assured only by proper selection and application of these parts.

TABLE 3 THERMOSTAT WIRE SIZE

Transformer VA	FLA	Wire Gauge	Maximum Distance In Feet
55	2.3	20 Gauge	45
		18 "	60
		16 "	100
		14 "	160
		12 "	250

COMPRESSOR CUT-OFF THERMOSTAT AND OUTDOOR THERMOSTATS

Heat pump compressor operation at outdoor temperatures below 0°F are neither desirable nor advantageous in terms of efficiency. Since most equipment at time of manufacture is not designated for any specific destination of the country and most of the equipment is installed in areas not approaching the lower outdoor temperature range, the compressor cut-offs are not factory installed.

Outdoor thermostats are available to hold off various banks of electric heat until needed as determined by outdoor temperature. The set point of either type of thermostat is variable with geographic region and sizing of the heating equipment to the structure. Utilization of the Heating Application Data and the heat loss calculation of the building are useful in determining the correct set points.

COMPRESSOR CUT-OFF AND OUTDOOR THERMOSTAT WIRING

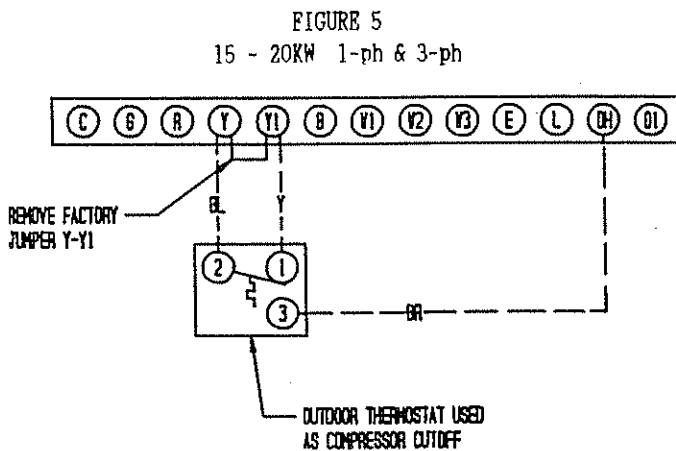
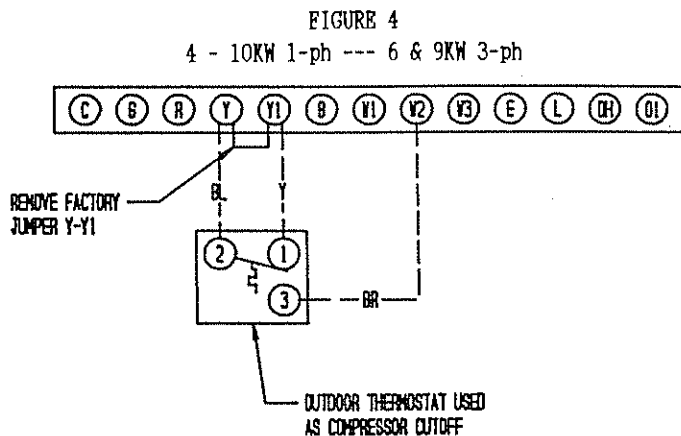

HEAT ANTICIPATION

Both of the thermostats shown below have a fixed heat anticipator for stage 1 with no adjustment required. Stage 2 has an adjustable anticipator for the W2 connection and fixed for the W3 connection. Both the W2 and W3 circuits are controlled by the stage 2 bulb. The only heat anticipator that needs to be checked is stage 2 and it should be set to match the load carried by the W2 circuit. The normal factory wiring provides for only one electric heat contactor to be controlled by W2, and the anticipator should be set at .40A. If special field wiring is done, it is best to actually measure the load but a good rule is .40A for EACH heat contactor controlled by W2.

TABLE 4

WALL THERMOSTAT AND SUBBASE COMBINATIONS			
Group	Thermostat	Subbase	Predominant Features
A	8403-017 (T874R1129)	8404-009 (Q674L1181)	Heat or Cool (1) No Auto
B	8403-018 (T874N1024)	8404-010 (Q674F1261)	Automatic Heat-Cool (2) Changeover Position

- (1) No automatic changeover position--must manually place in heat or cool. Reversing valve remains energized at all times system switch is in heat position (except during defrost cycle). No pressure equalization noise when thermostat is satisfied on either heating or cooling.
- (2) Allows thermostat to control both heating and cooling operation when set in "Auto" position. Reversing valve de-energizes at end of each "On" heating cycle.

IMPORTANT NOTE: Both thermostat and subbase combinations shown above incorporate the following features: Man-Auto fan switch, Off-Heat-Cool-Em. Heat Switch, and two (2) indicator lamps--one for emergency heat and one for compressor malfunction.

THERMOSTAT INDICATOR LAMPS

The red lamp marked "Em.Ht." comes on and stays on whenever the system switch is placed in the emergency heat position. The green lamp marked "check" will come on if there is any problem that prevents the compressor from running when it is supposed to be.

EMERGENCY HEAT POSITION

The operator of the equipment must manually place the system switch in this position. This is done when there is a known problem with the unit, or when the green "check" lamp comes on indicating a problem.

COMPRESSOR MALFUNCTION LIGHT

Actuation of the green "check" lamp is accomplished by a relay output from the heat pump control board which is factory installed. Any condition such as loss of charge, high head pressure, etc., that will prevent compressor from operating will cause green lamp to activate. This is a signal to the operator of the equipment to place system in emergency heat position.

PART 3 -- START-UP

IMPORTANT INSTALLER NOTE

For improved start-up performance, wash the indoor coil with a dishwasher detergent.

CRANKCASE HEATERS

WB421 units are provided with compressor crankcase heat. WB601 and WB481 units are not provided with crankcase heat. These units utilize scroll compressors which do not require crankcase in this application.

The WB421 models have an insertion well-type heater located in the lower section of the compressor housing. This is a self-regulating type heater that draws only enough power to maintain the compressor at a safe temperature on these units.

Some form of crankcase heat is essential to prevent liquid refrigerant from migrating to the compressor, causing oil pump out on compressor start-up and possible valve failure due to compressing a liquid.

The decal in Figure 6 is affixed to all WB421 units detailing start-up procedure. This is very important. Please read carefully.

HIGH PRESSURE SWITCH

The WB481 and WB601 models are supplied with a remote reset high pressure switch. If tripped, this pressure switch may be reset by turning the thermostat off then back on again.

SERVICE HINTS

1. Caution homeowner to maintain clean air filters at all times. Also, not to needlessly close off supply and return air registers. This reduces air flow through the system, which shortens equipment service life as well as increasing operating costs.
2. Switching to heating cycle at 75°F or higher outside temperature may cause a nuisance trip of the remote reset high pressure switch. Turn thermostat off, then on to reset the high pressure switch.
3. The heat pump wall thermostats perform multiple functions. Be sure that all function switches are correctly set for the desired operating mode before trying to diagnose any reported service problems.
4. Check all power fuses or circuit breakers to be sure they are the correct rating.
5. Periodic cleaning of the outdoor coil to permit full and unrestricted airflow circulation is essential.

FIGURE 6

IMPORTANT

THESE PROCEDURES MUST BE FOLLOWED AT INITIAL START-UP AND AT ANY TIME POWER HAS BEEN REMOVED FOR 12 HOURS OR LONGER.

TO PREVENT COMPRESSOR DAMAGE WHICH MAY RESULT FROM THE PRESENCE OF LIQUID REFRIGERANT IN THE COMPRESSOR CRANKCASE.

1. MAKE CERTAIN THE ROOM THERMOSTAT IS IN THE "OFF" POSITION. (THE COMPRESSOR IS NOT TO OPERATE).
2. APPLY POWER BY CLOSING THE SYSTEM DISCONNECT SWITCH. THIS ENERGIZES THE COMPRESSOR HEATER WHICH EVAPORATES THE LIQUID REFRIGERANT IN THE CRANKCASE.
3. ALLOW 4 HOURS OR 60 MINUTES PER POUND OF REFRIGERANT IN THE SYSTEM AS NOTED ON THE UNIT RATING PLATE, WHICHEVER IS GREATER.
4. AFTER PROPERLY ELAPSED TIME THE THERMOSTAT MAY BE SET TO OPERATE THE COMPRESSOR.
5. EXCEPT AS REQUIRED FOR SAFETY WHILE SERVICING — DO NOT OPEN SYSTEM DISCONNECT SWITCH.

7961-061

SEQUENCE OF OPERATION

COOLING--Circuit R-Y makes at thermostat pulling in compressor contactor, starting the compressor and outdoor motor. The G (indoor motor) circuit is automatically completed on any call for cooling operation or can be energized by manual fan switch on subbase for constant air circulation.

HEATING--A 24V solenoid coil on reversing valve controls heating cycle operation. Two thermostat options, one allowing "Auto" changeover from cycle to cycle and the other constantly energizing solenoid coil during heating season and thus eliminating pressure equalization noise except during defrost, are to be used. On "Auto" option, a circuit is completed from R-W1 and R-Y on each heating "on" cycle, energizing reversing valve solenoid and pulling in compressor contactor starting compressor and outdoor motor. R-G also make starting indoor blower motor. Heat Pump heating cycle now in operation. The second option has no "Auto" changeover position, but instead energizes the reversing valve solenoid constantly whenever the system switch on subbase is placed in "Heat" position, the "B" terminal being constantly energized from R. A thermostat demand for heat completes R-Y circuit, pulling in compressor contactor starting compressor and outdoor motor. R-G also make starting indoor blower motor.

PRESSURE SERVICE PORTS

High and low pressure service ports are installed on all units so that the system operating pressures can be observed. Pressure curves can be found later in the manual covering all models on both cooling and heating cycles. It is imperative to match the correct pressure curve to the unit by model number.

DEFROST CYCLE

The defrost cycle is controlled by temperature and time on the solid state heat pump control.

When the outdoor temperature is in the lower 40°F temperature range or colder, the outdoor coil temperature is 32°F or below. This coil temperature is sensed by the coil sensor mounted near the bottom of the outdoor coil. Once coil temperature reaches 30°F or below, the coil sends a signal to the control logic of the heat pump control and the defrost timer will start.

After 60 (90 or 30) minutes at 30°F or below, the heat pump control will place the system in the defrost mode.

During the defrost mode, the refrigerant cycle switches back to the cooling cycle, the outdoor motor stops, electric heaters are energized, and hot gas passing through the outdoor coil melts any accumulator frost. When the temperature rises to approximately 57°F, the coil sensor will send a signal to the heat pump control which will return the system to heating operations automatically.

If some abnormal or temporary condition such as a high wind causes the heat pump to have a prolonged defrost cycle, the heat pump control will restore the system to heating operation automatically after 10 minutes.

There are three settings on the heat pump control--30 minute, 60 minute, and 90 minute. Most models are shipped wired on the 60 minute setting for greatest operating economy. If special circumstances require a change to another time, remove wire connected to terminal 60 and reconnect to desired terminal.

There is a cycle speed up jumper on the control. This can be used to reduce the time between defrost cycle operation without waiting for time to elapse.

There is an initial defrost (sen jmp) jumper on the control that can be used at any outdoor ambient during the heating cycle to simulate a 0° coil temperature. This can be used to check defrost operation of the unit without waiting for the outdoor ambient to fall into the defrost region.

FIGURE 7
DEFROST CONTROL BOARD

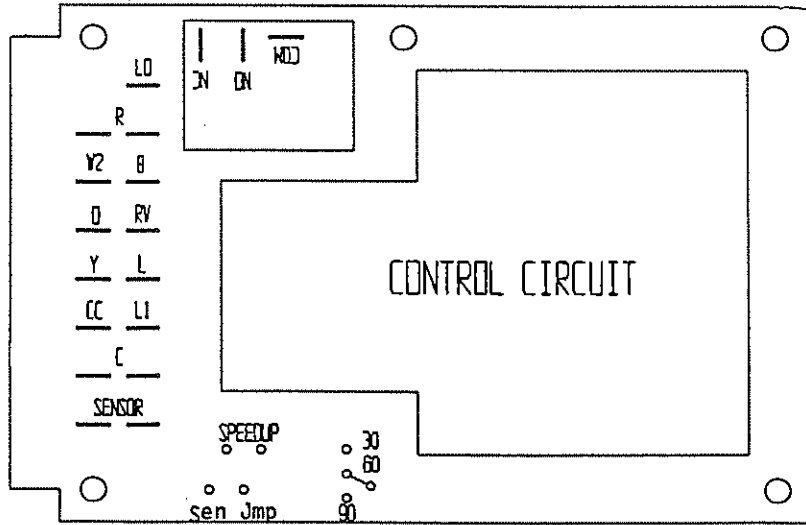

PART 4 -- TROUBLESHOOTING

SOLID STATE HEAT PUMP CONTROL TROUBLESHOOTING PROCEDURE

1. Turn on AC power supply to indoor and outdoor units.
2. Turn thermostat blower switch to fan on--the indoor blower should start. (If it doesn't, troubleshoot indoor unit and correct problem).
3. Turn thermostat blower switch to auto position. Indoor blower should stop.
4. Set system switch to heat or cool. Adjust thermostat to call for heat or cool--The indoor blower, compressor, and outdoor fan should start.

NOTE: If there was no power to 24 volt transformer, the compressor and outdoor fan motor will not start for 5 minutes. This is because of the compressor short cycle protection.

TABLE 5 TROUBLESHOOTING

Sympton	Possible Causes	What to Check	How To Check Or Repair
Compressor contactor does not energize (cooling or heating)	Control circuit wiring	Check for R connection at unit, and 24V between R-C.	Run R connection to outdoor unit to power heat pump control.
	Compressor lock out	1. Check for 24V between L1-C on heat pump control. 2. Check across high pressure switch.	1. If no voltage between L1-C turn thermostat off and on again to reset high pressure switch. 2. If high pressure switch is open and will not reset, replace high pressure switch.
	Compressor short cycle protection	Check for 24V between CC-C and Y-C on heat pump control.	1. If no voltage between CC-C jumper speed up terminal and within 10 seconds power should appear between CC-C. Remove speed up jumper after 10 seconds.
	Heat pump control defective	Check all other possible causes. Manual 2100-065	Replace heat pump control.
	Contactor defective	Check for open or shorted coil winding.	Replace contactor.
Fan outdoor motor does not run (cooling or heating except during defrost)	Motor defective	Check for open or shorted motor winding	Replace motor.
	Motor capacitor defective	Check capacitor rating. Check for open or shorted capacitor.	Replace capacitor.
	Heat pump control defective	Check across fan relay on heat pump control. (Com-NC)	Replace heat pump control.
Reversing valve does not energize (heating only)	Reversing valve solenoid coil defective	Check for open or shorted coil.	Replace solenoid coil.
	Heat pump control defective	Check for 24V between RV-C and B-C.	1. Check control circuit wiring. 2. Replace heat pump control.
Unit will not go into defrost (heating only)	Temperature sensor or heat pump control defective	Disconnect temperature sensor from board and jumper across speed up terminals and sen jmp terminals. This should cause the unit to go through a defrost cycle within one minute.	1. If unit goes through defrost cycle, replace temperature sensor. 2. If unit does not go through defrost cycle, replace heat pump control.
Unit will not come out of defrost (heating only)	Temperature sensor or heat pump control defective	Jumper across speed up terminals. This should cause the unit to come out of defrost within one minute.	1. If unit comes out of defrost cycle, replace temperature sensor. 2. If unit does not come out of defrost cycle, replace heat pump control.

CHECKING TEMPERATURE SENSOR OUTSIDE UNIT CIRCUIT

1. Disconnect temperature sensor from board and from outdoor coil.
2. Use an ohmmeter and measure the resistance of the sensor. Also use ohmmeter to check for short or open.
3. Check resistance reading to chart of resistance use sensor ambient temperature. (Tolerance of part is $\pm 10\%$).
4. If sensor resistance reads very low, then sensor is shorted and will not allow proper operation of the heat pump control.
5. If sensor is out of tolerance, shorted, open, or reads very low ohms then it should be replaced.

TEMPERATURE F VS RESISTANCE R OF TEMPERATURE SENSOR

F	R	F	R	F	R
-25.0	196871	25.0	39898	75.0	10501
-24.0	190099	26.0	38757	76.0	10247
-23.0	183585	27.0	37652	77.0	10000
-22.0	177318	28.0	36583	78.0	9760
-21.0	171289	29.0	35548	79.0	9526
-20.0	165487	30.0	34545	80.0	9299
-19.0	159904	31.0	33574	81.0	9077
-18.0	154529	32.0	32634	82.0	8862
-17.0	149355	33.0	31723	83.0	8653
-16.0	144374	34.0	30840	84.0	8449
-15.0	139576	35.0	29986	85.0	8250
-14.0	134956	36.0	29157	86.0	8057
-13.0	130506	37.0	28355	87.0	7869
-12.0	126219	38.0	27577	88.0	7686
-11.0	122089	39.0	26823	89.0	7507
-10.0	118108	40.0	26092	90.0	7334
-9.0	114272	41.0	25383	91.0	7165
-8.0	110575	42.0	24696	92.0	7000
-7.0	107010	43.0	24030	93.0	6840
-6.0	103574	44.0	23384	94.0	6683
-5.0	100260	45.0	22758	95.0	6531
-4.0	97064	46.0	22150	96.0	6383
-3.0	93981	47.0	21561	97.0	6239
-2.0	91008	48.0	20989	98.0	6098
-1.0	88139	49.0	20435	99.0	5961
0.0	85371	50.0	19896	100.0	5827
1.0	82699	51.0	19374	101.0	5697
2.0	80121	52.0	18867	102.0	5570
3.0	77632	53.0	18375	103.0	5446
4.0	75230	54.0	17898	104.0	5326
5.0	72910	55.0	17434	105.0	5208
6.0	70670	56.0	16984	106.0	5094
7.0	68507	57.0	16547	107.0	4982
8.0	66418	58.0	16122	108.0	4873
9.0	64399	59.0	15710	109.0	4767
10.0	62449	60.0	15310	110.0	4663
11.0	60565	61.0	14921	111.0	4562
12.0	58745	62.0	14544	112.0	4464
13.0	56985	63.0	14177	113.0	4367
14.0	55284	64.0	13820	114.0	4274
15.0	53640	65.0	13474	115.0	4182
16.0	52051	66.0	13137	116.0	4093
17.0	50514	67.0	12810	117.0	4006
18.0	49028	68.0	12492	118.0	3921
19.0	47590	69.0	12183	119.0	3838
20.0	46200	70.0	11883	120.0	3757
21.0	44855	71.0	11591	121.0	3678
22.0	43554	72.0	11307	122.0	3601
23.0	42295	73.0	11031	123.0	3526
24.0	41077	74.0	10762	124.0	3452

FAN BLADE SETTING DIMENSIONS

Shown in the drawing below are the correct fan blade setting dimensions for proper air delivery across the outdoor coil.

Any service work requiring removal or adjustment in the fan and/or motor area will require that the dimensions below be checked and blade adjusted in or out on the motor shaft accordingly.

FIGURE 8

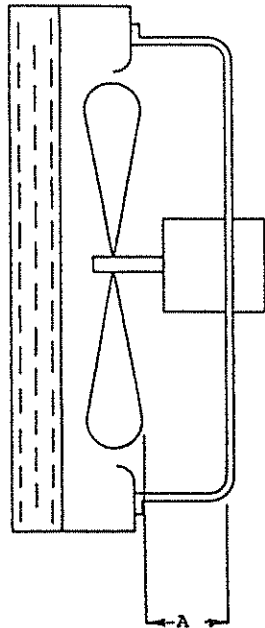

TABLE 6

Model	Dimension A
WH421 WH481 WH601	1.75

REMOVAL OF THE FAN SHROUD

1. Disconnect all power to unit.
2. Remove the screws holding both grills--one on each side of unit--and remove grills.
3. Remove screws holding fan shroud to condenser and bottom. (9) screws.
4. Unwire condenser fan motor.
5. Slide complete motor, fan blade, and shroud assembly out the left side of the unit.
6. Service motor/fan as needed.
7. Reverse steps to reinstall.

REFRIGERANT CHARGE

The correct system R-22 charge is shown on the unit rating plate. Optimum unit performance will occur with a refrigerant charge resulting in a suction line temperature (6" from compressor) as shown in the following table:

TABLE 7 REFRIGERANT CHARGE

Model	Rated Airflow	°	°
		95 F OD Temperature	82 F OD Temperature
WH421	1400	52 - 54	62 - 64
WH481	1550	53 - 55	62 - 64
WH601	1700	52 - 54	61 - 63

The above suction line temperatures are based upon 80°F dry bulb/67°F wet bulb (50% R.H.) temperature and rated airflow across the evaporator during cooling cycle.

TABLE 8 INDOOR BLOWER PERFORMANCE--CFM @ 230V

E.S.P. In H2O	WH421, WH481		WH601	
	Lo 230V	Hi 230V	Lo 230V	Hi 230V
	Dry/Wet Coil	Dry/Wet Coil	Dry/Wet Coil	Dry/Wet Coil
.0	1650 / 1600	1885 / 1800	1600 / 1450	2200 / 2000
.1	1550 / 1500	1770 / 1665	1525 / 1375	2100 / 1900
.2	1450 / 1400	1635 / 1540		2000 / 1800
.3	1350 / 1300	1500 / 1400		1875 / 1700
.4	1300 / 1175	1370 / 1285		1775 / 1600
.5	---	1250 / 1150		1650 / 1475

TABLE 9 Recommended Operating Ranges

Model	Rated CFM*	Rated ESP*	Recommended Airflow Range
WH421	1400	.30	1600 - 1150
WH481	1550	.20	1750 - 1285
WH601	1700	.30	1950 - 1375

*Rated CFM and ESP on high speed tap.

TABLE 8 MAXIMUM ESP OF OPERATION

Model Speed KW	WH421		WH481		WH601	
	High Speed	Low Speed	High Speed	Low Speed	High Speed	Low Speed
-A00	.50	.50	.50	.50	.50	.40
-A05	.50	.50	.50	.50	.50	.25
-A10	.50	.45	.50	.45	.50	.25
-A15	.50	.45	.50	.45	.50	.25
-A20	---	---	.50	.45	.50	.25
-B00	.50	.50	.50	.50	.50	.40
-B09	.50	.45	.50	.45	.50	.30
-B15	.50	.45	.50	.45	.50	.30
-B18	---	---	.50	.45	.50	.30
-C00	.50	.50	.50	.50	.50	.40
-C09	.50	.40	.50	.40	.50	.35
-C15	.50	.40	.50	.40	.50	.35

Values shown are for units equipped with STD 1" throw-away filter or 1" washable filter. Derate ESP by .15 for 2" pleated filters.

TABLE 11

COOLING -- Pressure (PSI)

Air Temperature Entering Outdoor Coil °F

Model	Return Air Temperature	Pressure	°	°	°	°	°	°	°	°	°
			75	80	85	90	95	100	105	110	115
WH421	75° DB 62° WB	Low Side	74	75	77	78	79	80	80	81	82
		High Side	205	220	235	251	266	282	297	313	329
	80° DB 67° WB	Low Side	79	80	82	83	84	85	85	86	86
		High Side	210	226	241	257	273	289	305	321	337
	85° DB 72° WB	Low Side	85	86	88	89	90	91	91	92	92
		High Side	217	233	250	266	283	300	316	333	349
WH481	75° DB 62° WB	Low Side	74	75	77	78	79	80	80	81	81
		High Side	221	231	242	255	270	287	305	326	348
	80° DB 67° WB	Low Side	79	80	82	83	84	85	85	86	86
		High Side	214	233	252	271	289	307	324	341	357
	85° DB 72° WB	Low Side	85	86	88	89	90	91	91	92	92
		High Side	221	241	261	280	299	317	335	352	369
WH601	75° DB 62° WB	Low Side	70	71	73	74	75	76	78	79	81
		High Side	225	233	246	262	282	306	333	364	399
	80° DB 67° WB	Low Side	75	76	78	79	80	81	83	85	87
		High Side	231	239	252	269	289	313	341	373	409
	85° DB 72° WB	Low Side	81	82	84	85	86	88	90	93	96
		High Side	240	248	261	278	299	324	353	386	410

TABLE 12

HEATING -- Pressures (PSI)

Air Temperature Entering Outdoor Coil °F

Model	Return Air Temperature	Pressure	0	5	10	15	17	20	25	30	35	40	45	47	50	55	60
			WH421	70°	Low Side	21	25	27	29	30	32	35	39	43	48	53	55
High Side	141	147			152	158	160	163	169	174	180	190	201	206	214	229	246
WH481	70°	Low Side	16	19	22	26	27	29	32	36	39	45	51	54	59	67	77
		High Side	161	164	168	172	174	177	182	188	195	202	210	213	218	227	236
WH601	70°	Low Side	23	25	27	28	29	30	32	33	35	42	51	55	62	75	91
		High Side	178	182	185	189	191	192	194	196	205	218	236	244	257	283	313

Low side pressure \pm 2 PSIGHigh side pressure \pm 5 PSIG

Tables are based upon rated CFM (airflow) across the evaporator coil and should be found under section titled "Refrigerant Charge" elsewhere in manual. If there is any doubt as to correct operating charge being in the system, the charge should be removed, system evacuated, and recharged to serial plate instructions.

TABLE 13

OPTIONAL ACCESSORIES

Model	Description	W	W	W	W	W	W	W	W
		H	H	H	H	H	H	H	H
		4	4	4	4	4	4	6	6
		2	2	2	8	8	8	0	0
		1	1	1	1	1	1	1	1
		-	-	-	-	-	-	-	-
		A	B	C	A	B	C	A	B
		C							
EHWH42-A05	Heater Packages	X							
EHWH42-A10	Heater Packages	X							
EHWH42-A15	Heater Packages	X							
EHWH04-A05	Heater Packages				X			X	
EHWH04-A10	Heater Packages				X			X	
EHWH04-A15	Heater Packages				X			X	
EHWH04-A20	Heater Packages				X			X	
EHWH05-B09	Heater Packages		X			X			X
EHWH05-B15	Heater Packages		X			X			X
EHWH04-B18	Heater Packages					X			X
EHWH05-C09	Heater Packages			X			X		X
EHWH05-C15	Heater Package			X			X		X
BOP-5	Blank Off Plate	X	X	X	X	X	X	X	X
BFAD-5	Barometric Fresh Air Damper	X	X	X	X	X	X	X	X
MFAD-5	Motorized Fresh Air Damper	X	X	X	X	X	X	X	X
CRV-5	Classroom Ventilator With Exhaust	X	X	X	X	X	X	X	X
EIFM-5	Economizer With Exhaust	X	X	X	X	X	X	X	X
CMH-3	Low Pressure Control (LPC)	X	X	X	X	X	X	X	X
CMH-7	Low Ambient Control (LAC)	X	X		X	X		X	X
CMH-9	LAC + LPC	X	X		X	X		X	X
CMH-14	Outdoor Thermostat (ODT)	X	X	X	X	X	X	X	X
CMC-15	Start Kit (SK)	X							
WMCB-05B	Circuit Breaker Kit		X						
WMCB-06B	Circuit Breaker Kit					X			
WMPD-01	Circuit Breaker Kit			X			X		X
WMCB-07B	Circuit Breaker Kit							X	
WMCB-09A	Circuit Breaker Kit				X			X	
WMCB-08A	Circuit Breaker Kit	X							

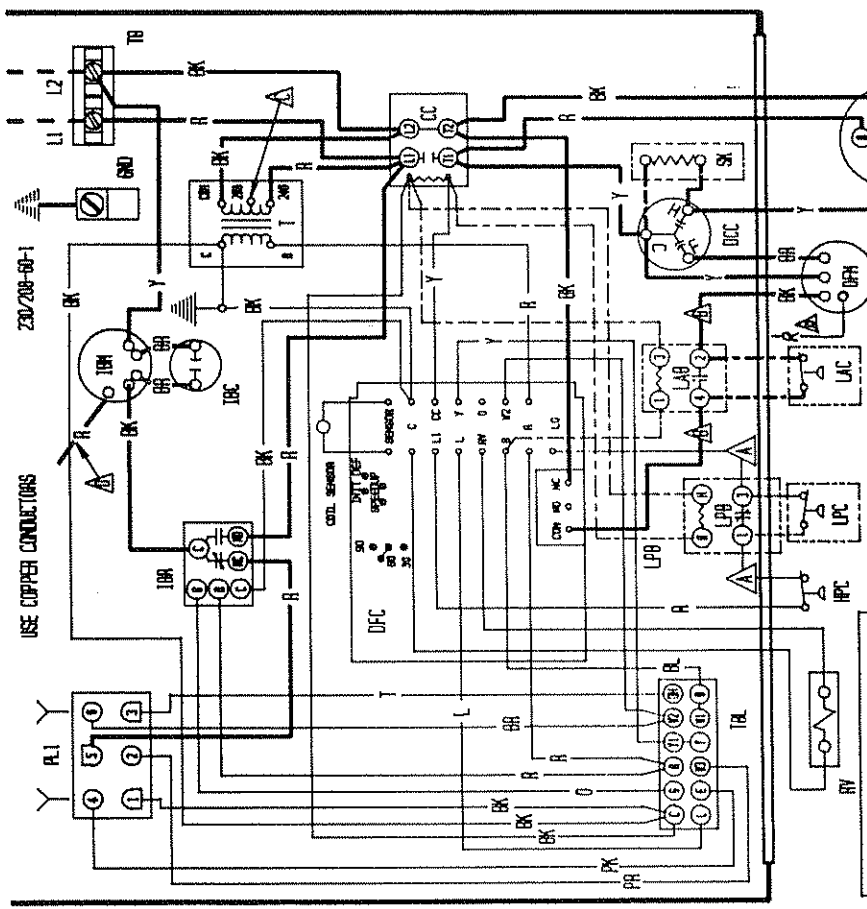
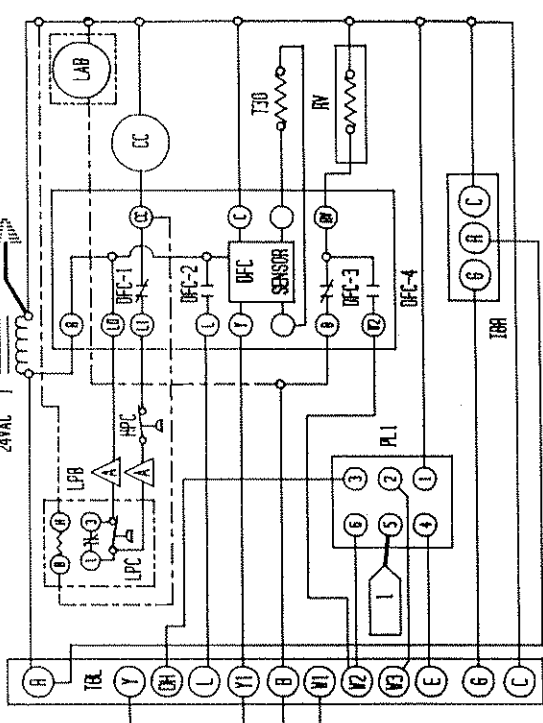
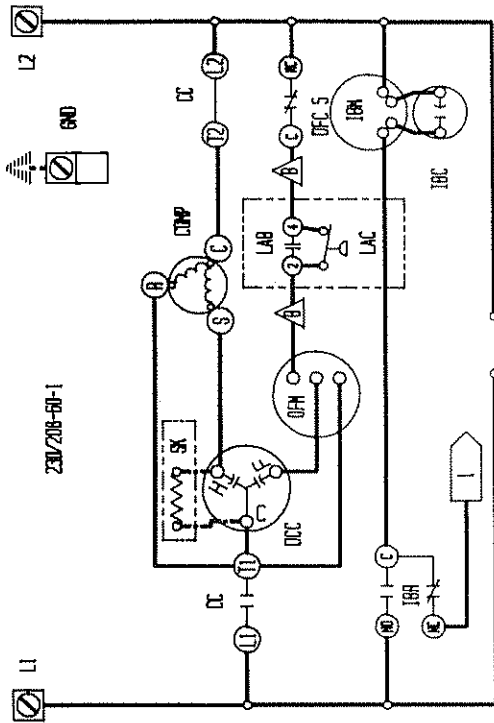

USE COPPER CONDUCTORS

COMPONENT CODE	INDUOR BLOWER MOTOR	INDUOR BLOWER RELAY	LOW AMBIENT BYPASS CONTROL	LOW AMBIENT CONTROL	LOW PRESSURE BYPASS	LOW PRESSURE CONTROL	LIMIT SWITCH	OUTDOOR FAN MOTOR	PLUS #1	REV. VALVE SOLINOID	START KIT	TRANSFORMER	TERMINAL BLOCK	LOW VOLTAGE TERMINAL BLOCK	THERMAL	OUTOFF
CB1	IBR	IBR	LAC	LAC	LPC	LPC	LS	OPH	PL1	RV	SK	T	TEL	TEL	TCO	
CB2																
CC																
CCP																
DCC																
DFC																
IBR																
GND																
H1																
H2																
H2																
HPC																
IBC																

MOVE RED WIRE TO 208V TAP FOR 208V OPERATION

RED (LOW) BLACK (HIGH) WIRE APPLICABLE

Labeled wires connect if no options used.

FACTORY STD.	FIELD	OPTIONAL
HIGH VOLTAGE		
LOW VOLTAGE		
ACCESSORY		

COLOR CODE	
BK	BLACK
BR	BROWN
OR	ORANGE
Y	YELLOW
G	GREEN
BL	BLUE
RD	RED
W	WHITE
V	VIOLET
P	PURPLE
PK	PINK
L	LAUREN
S	SLATE
T	TAN

BARD MFG. CO.	
ENG.	4056-113
DRAW.	DAY
CHK./APPR.	

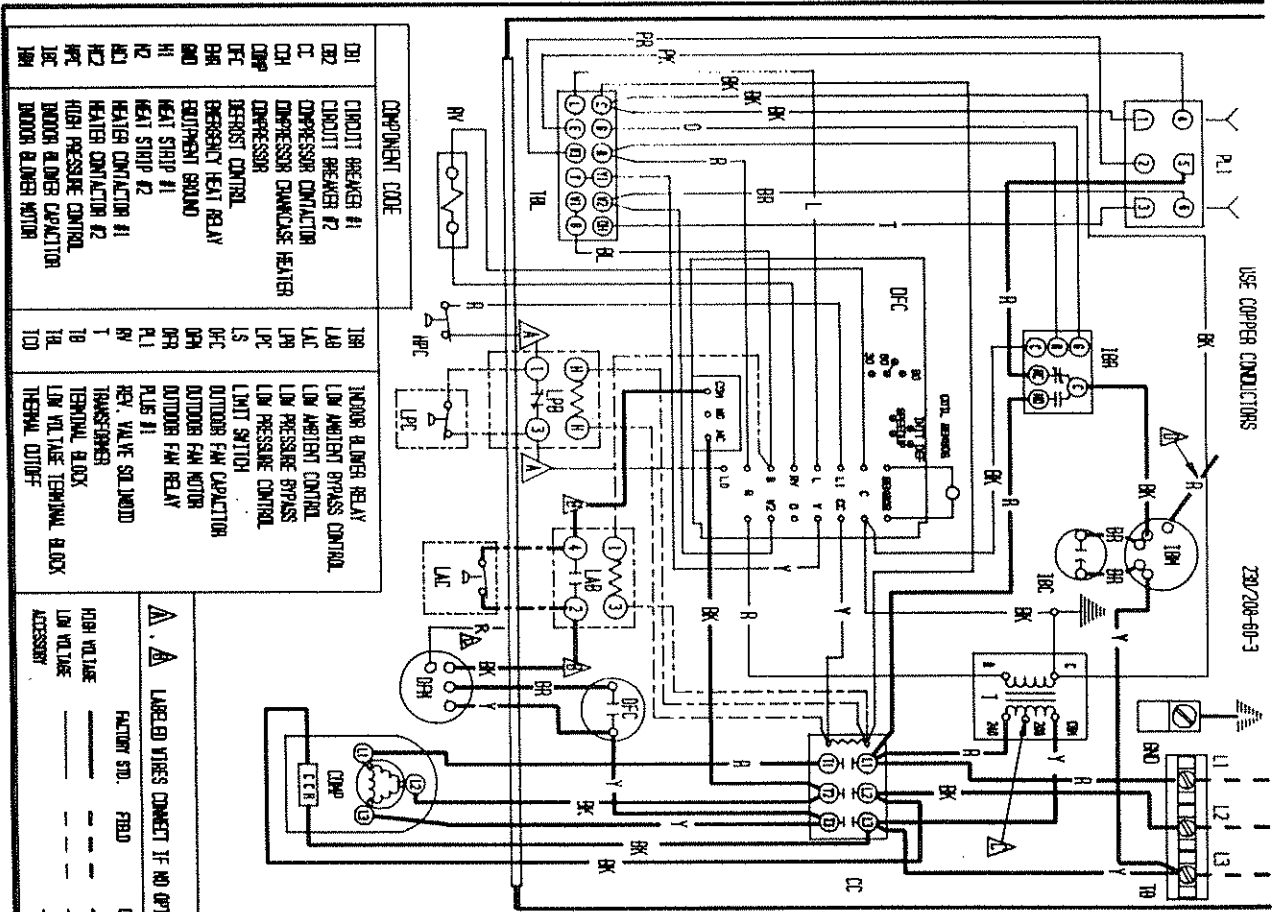

USE COPPER CONDUCTORS

230/208-60-3

COMPONENT CODE	
D01	CIRCUIT BREAKER #1
D02	CIRCUIT BREAKER #2
D03	COMPRESSOR CONTACTOR
D04	COMPRESSOR OVERCURE HEATER
D05	COMPRESSOR
D06	DEFROST CONTROL
D07	EMERGENCY HEAT RELAY
D08	EQUIPMENT GROUND
D09	HEAT STRIP #1
D10	HEAT STRIP #2
D11	HEATER CONTACTOR #1
D12	HEATER CONTACTOR #2
D13	HIGH PRESSURE CONTROL
D14	INDOOR BLOWER CAPACITOR
D15	INDOOR BLOWER MOTOR

I01	INDOOR BLOWER RELAY
I02	LOW AMBIENT BYPASS CONTROL
I03	LOW AMBIENT CONTROL
I04	LOW PRESSURE BYPASS
I05	LOW PRESSURE CONTROL
I06	LIMIT SWITCH
I07	OUTDOOR FAN CAPACITOR
I08	OUTDOOR FAN MOTOR
I09	OUTDOOR FAN RELAY
I10	REV. VALVE SOLINOID
I11	TRANSFORMER
I12	TEMPERATURE BLOCK
I13	LOW VOLTAGE TERMINAL BLOCK
I14	TEMPERATURE BLOCK
I15	TEMPERATURE BLOCK

▲ Labeled wires connect if no options used.

▲ WIRE RED WIRE TO 208V TAP FOR 208V OPERATION

▲ RED (LOW) BACK (HIGH) WERE APPLICABLE

FACTORY STD.	FIBD	OPTIONAL
HIGH VOLTAGE	---	---
LOW VOLTAGE	---	---
ACCESSORY	---	---

COLOR CODE		RED (LOW) BACK (HIGH) WERE APPLICABLE	
BK	BLACK	Y	YELLOW
BR	BROWN	GR	GREEN
R	RED	BL	BLUE
0	ORANGE	W	WHITE
		(S)	(S)
		SLT	SLATE
		V	VIOLET
		(R)	(R) PURPLE
		PK	PINK
		L	LAVENDER

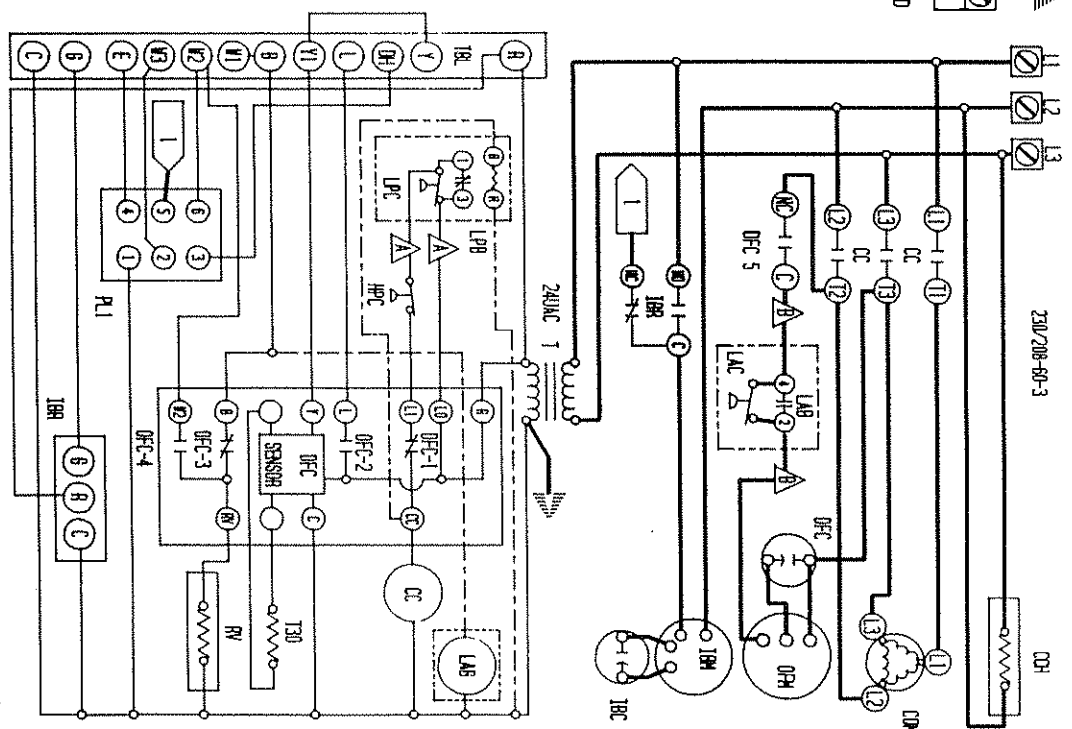

230/208-60-3

BARCO MFG. CO.
 DMC: 4025-210 9
 DATE: 9-16-92
 DK/MPR

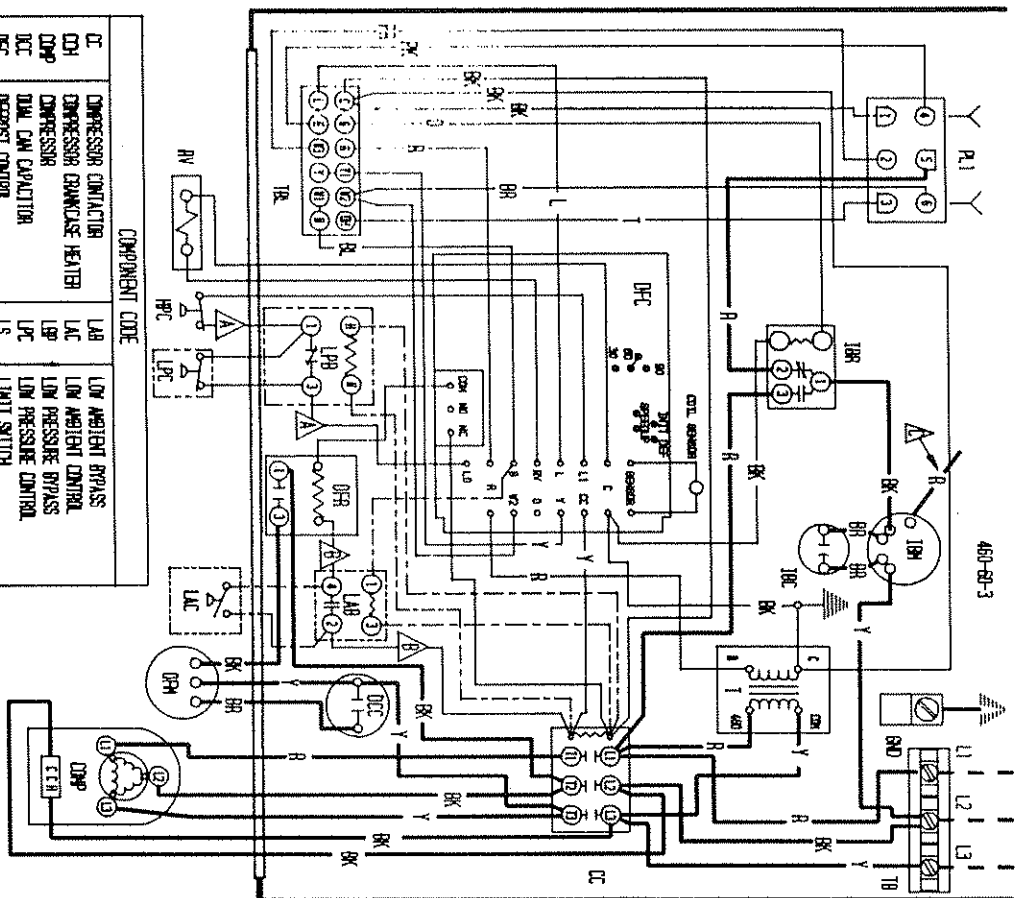

COMPONENT CODE

CC	COMPRESSOR CONTACTOR	LAB	LOW AMBIENT PRESS
CH	COMPRESSOR CRANKCASE HEATER	LAC	LOW AMBIENT CONTROL
DMP	COMPRESSOR	LCP	LOW PRESSURE BYPASS
DC	DUAL CAPACITOR	LPC	LOW PRESSURE CONTROL
DFC	DEFROST CONTROL	LS	LIMIT SWITCH
DR	DEFROST HEAT RELAY	DFH	OUTDOOR FAN MOTOR
DR	DEFROST HEAT RELAY	DFR	OUTDOOR FAN RELAY
HS	HEAT STRIP #1	PLS #1	PULL DISCONNECT
HS	HEAT STRIP #2	PLS #2	REY. VALVE SOLINOID
HC	HEATER CONTACTOR #1	STK	START KIT
HC	HEATER CONTACTOR #2	TR	TRANSFORMER
HC	HIGH PRESSURE CONTROL	TR	TERMINAL BLOCK
IR	INDOOR RUNNER CAPACITOR	TR	LOW VOLTAGE TERMINAL BLOCK
IR	INDOOR RUNNER MOTOR	TR	TEMP. DIFF.
IR	INDOOR RUNNER RELAY	TR	

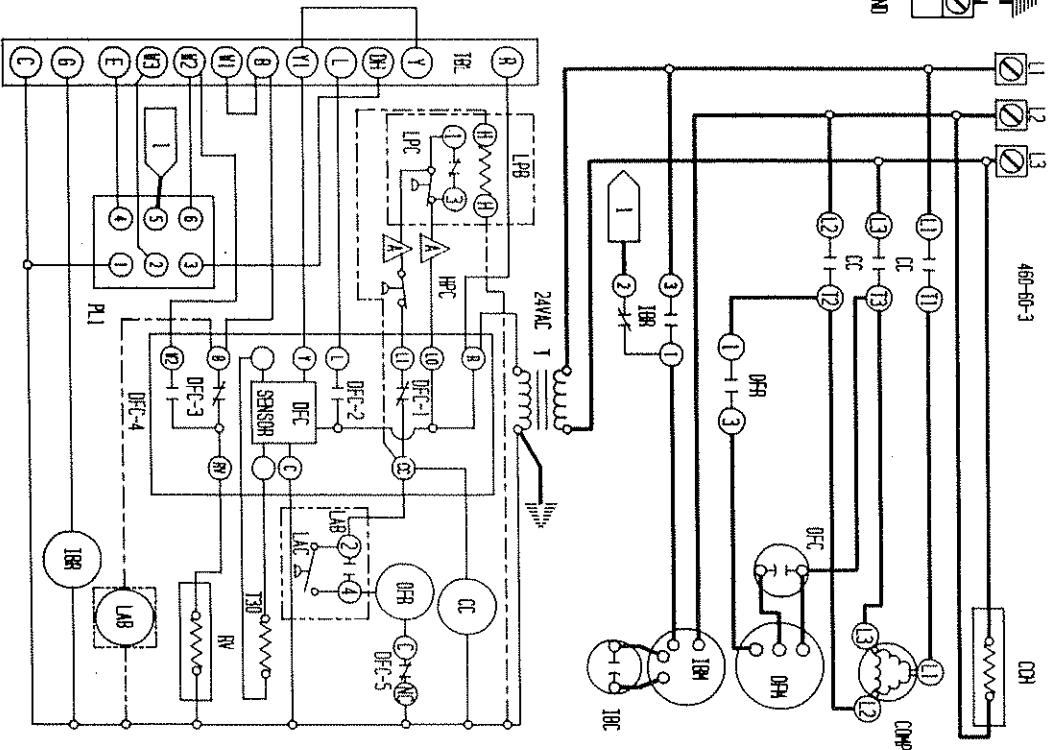

WIRING AND LABELING INFORMATION

▲ Labeled wires connect if no options used.

▲ Red (LOW) Black (HIGH)

FACTORY SUP.		OPTIONAL	
WIRE COLOR	WIRE COLOR	WIRE COLOR	WIRE COLOR
BLACK	Y	YELLOW	V
BROWN	B	GREEN	GR
RED	R	BLUE	BL
BROWN	W	WHITE	(S)
		VIOLET	V
		PURPLE	PR
		SLATE	SL
		TAU	T
		PINK	PK
		LAVENDER	LV

BARD HFC. CO.

DATE	4885-310 B
DATE	9-16-92
CHK. / APPR.	

