INSTALLATION INSTRUCTIONS

COMMERCIAL ROOM VENTILATORS WITH EXHAUST

**MODEL
CRV-5**

**For Use with Bard 3-1/2 thru 5 Ton
Wall Mount Air Conditioners
and Heat Pumps**



Bard Manufacturing Company
Bryan, Ohio 43506

*Since 1914...Moving ahead, just
as planned.*

Manual : 2100-222 D
Supersedes: Rev. C
File: Volume III Tab 19
Date: 01-12-99

Contents

General	1
General Information	1
Unpacking	1
Description	1
Installation	1
Basic Installation	1
Blade Adjustment for Desired Ventilation Air	7
Commercial Room Ventilator – WA, WH & WL Series	12

Figures

Figure 1	2
Figure 2	3
Figure 3	4
Figure 4	5
Figure 5	6
Figure 6	7
Figure 7	12
Figure 8	13

Tables

Table 1	8 & 9
Table 2	10
Table 3	10 & 11

Manufactured under U.S. patent number 5,301,744.
Other patents pending.

**COPYRIGHT JANUARY, 1999
BARD MANUFACTURING COMPANY
BRYAN, OHIO USA 43506**

GENERAL INFORMATION

The ventilator should only be installed by a trained heating and air conditioning technician. These instructions serve as a guide to the technician installing the ventilator package. They are not intended as a step by step procedure with which the mechanically inclined owner can install the package.

The ventilator housing is shipped in one carton which contains the electrical harness, miscellaneous hardware and installation instructions.

UNPACKING

Upon receipt of the equipment be sure to compare the model number found on the shipping label with the accessory identification information on the ordering and shipping document to verify that the correct accessory has been shipped.

Inspect the carton housing of each ventilator as it is received, and before signing the freight bill, verify that all items have been received and that there is no visible damage. Note any shortages or damage on all copies of the freight bill. The receiving party must contact the last carrier immediately, preferably in writing, requesting inspection by the carrier's agent. Concealed damage not discovered until after loading must be reported to the carrier within 15 days of its receipt.

DESCRIPTION

The CRV-5 ventilator is designed to be used with Bard 3-1/2 thru 5 ton wall mount series air conditioners and heat pumps. They are electromechanical vent systems designed to provide fresh air to meet indoor air quality standards with built in exhaust provisions.

INSTALLATION

BASIC INSTALLATION

1. Unpack the ventilator assembly which includes the integral ventilator with attached electrical harness and miscellaneous hardware.

WARNING

Open and lock unit disconnect switch before installing this accessory to prevent injury or death due to electrical shock or contact with moving parts. Turn thermostat to off.

MODEL	FOR USE WITH FOLLOWING UNITS		
	WA1881 WA241	WH181 WH241	WL181 WL241
CRV-2	WA301 WA361	WH301 WH361	WL301 WL361
CRV-3	WA421 WA482 WA602	WH421 WH482 WH602	WL421 WL482 WL602

2. Remove and save the existing exterior blower access and service access panels on the Bard wall mount unit. (See Figure 1.)

FIGURE 1

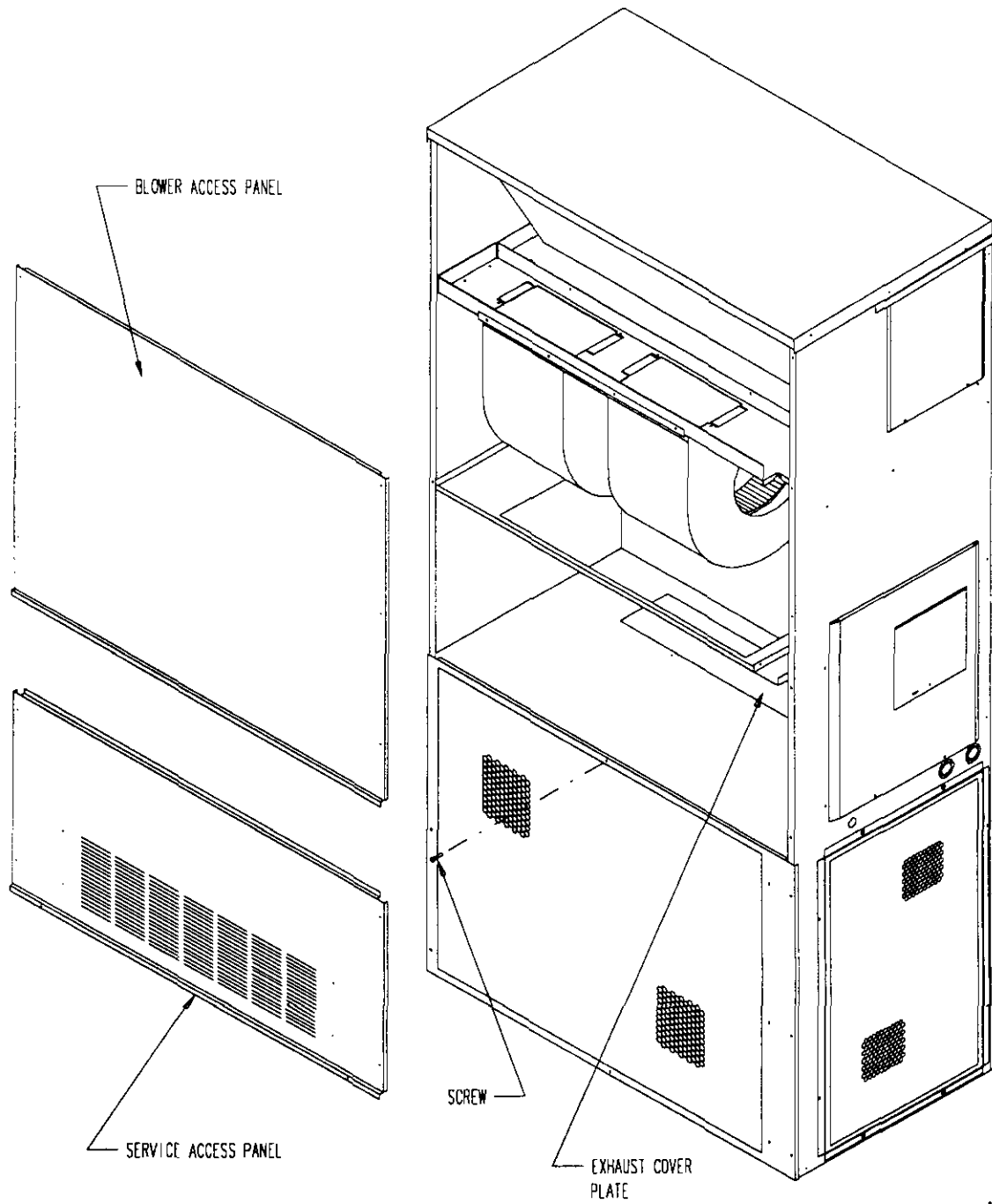

MIS-425

3. Remove and save existing unit air filter and screws from front center grille. (See Figure 2.)

4. Remove and discard the exhaust cover plate.

FIGURE 2

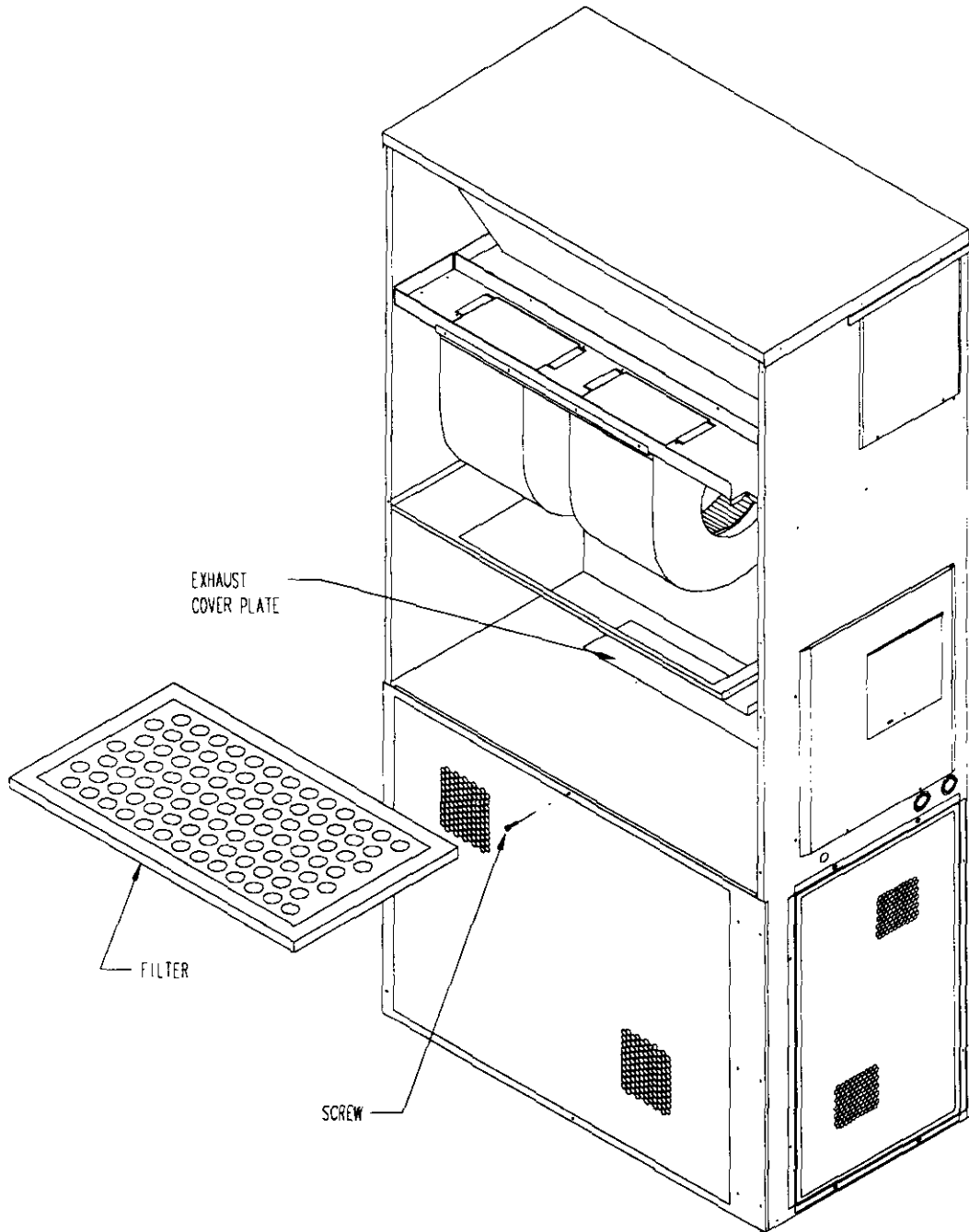

MIS-427

5. For Installation of Left Hand Units Only – Remove strain relief in right side of CRV. Un-clip the (2) wire ties holding the wire harness. Reroute wires to left side of CRV. Reinstall wire ties in left side holes. Route wires through left side and reinstall strain relief. (See Figure 3.)

FIGURE 3

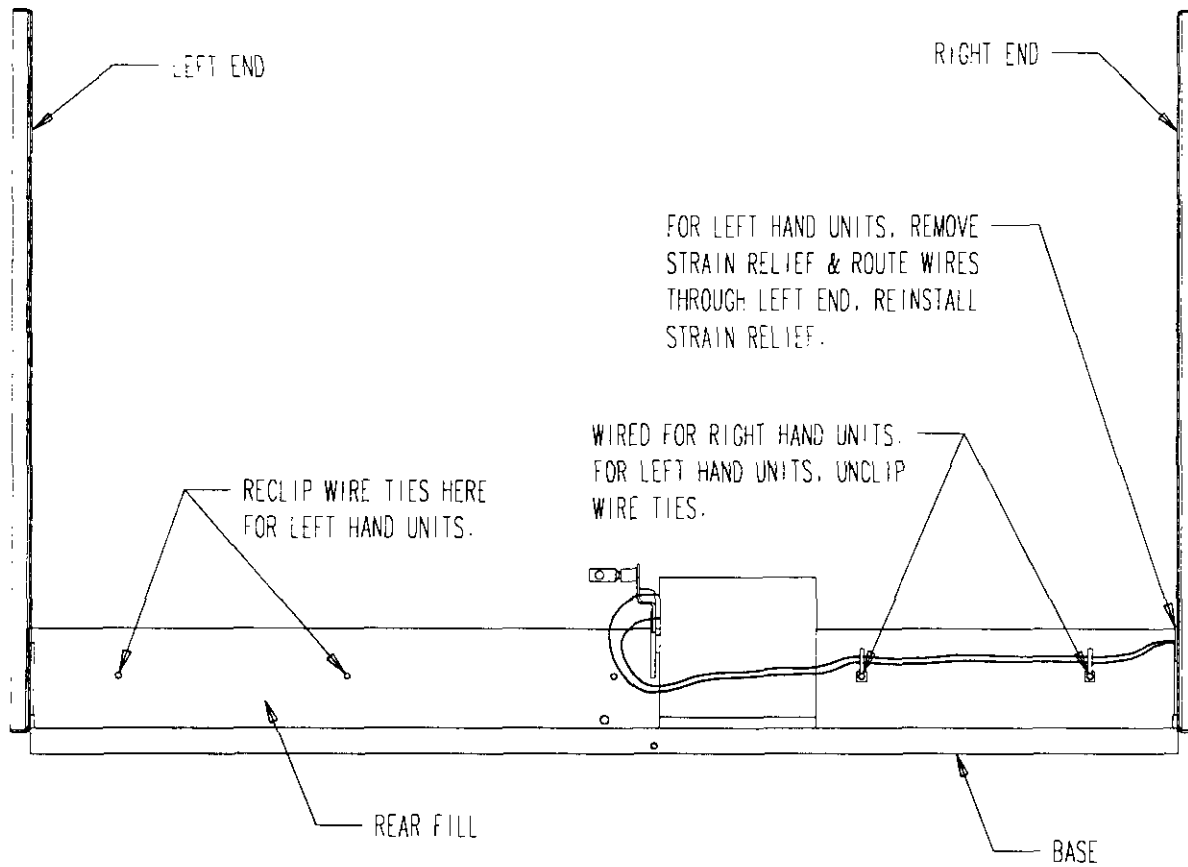

MIS-1334

6. Install ventilator by inserting the ventilator into the unit to the far left side clearing the right filter bracket. Once the ventilator is fully inserted, slide the ventilator to the right until it is tight against the back of the control panel. (See Figure 4.)

IMPORTANT: Position front lip of ventilator on top of front grille and condenser partition. (See Figure 4 inset.) This is important to ensure proper drainage of any water entering damper assembly.

7. Open control panel to gain access to unit low voltage terminal block.
8. Route electrical harness leads through the 7/8" bushing in control panel (Figure 4) into low voltage box.

FIGURE 4

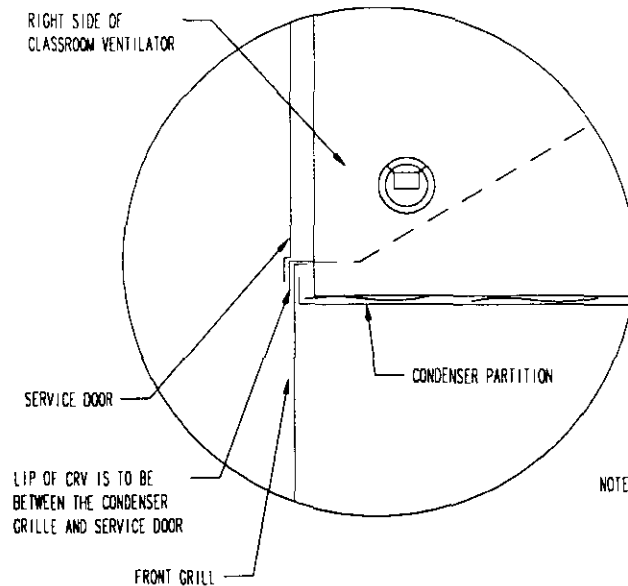
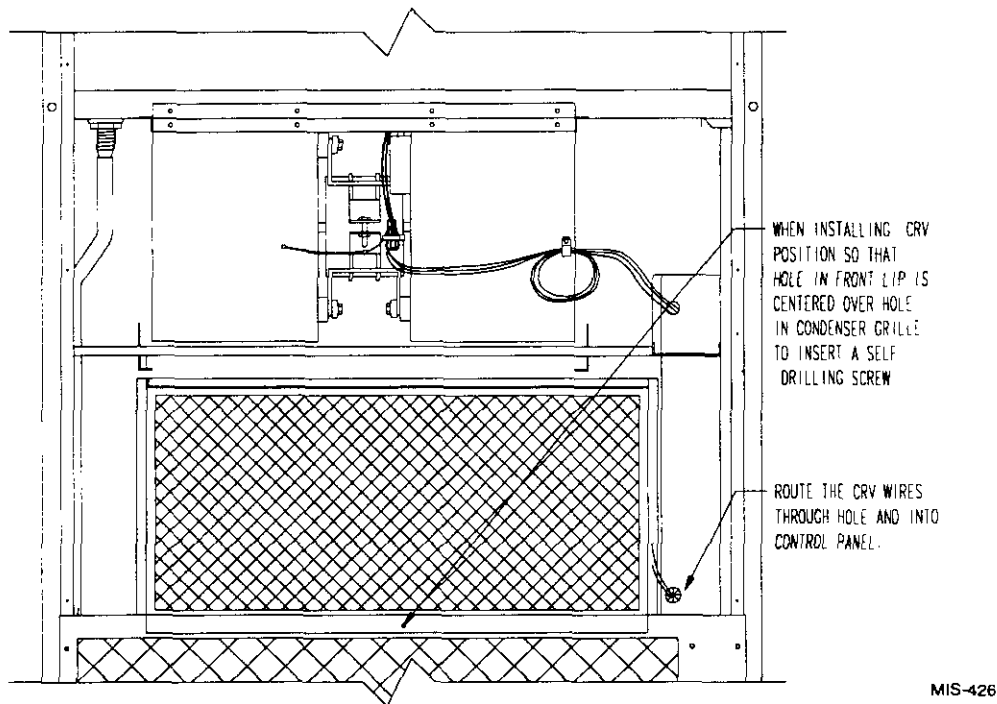
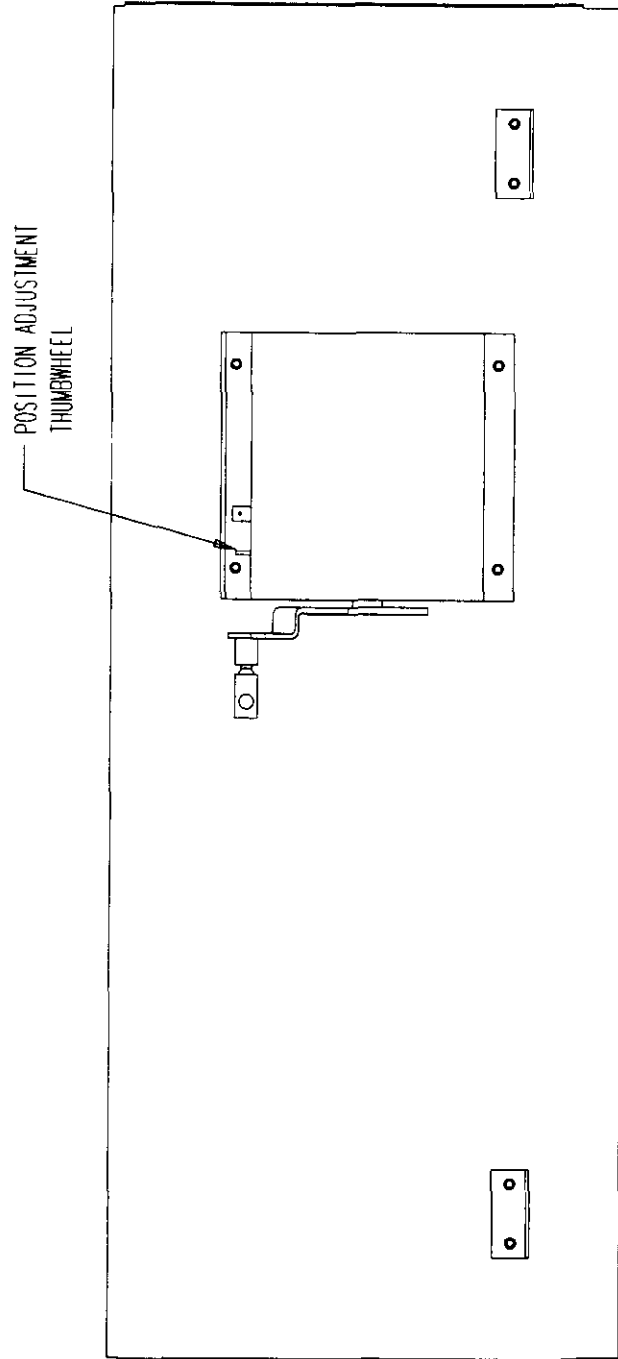

FIGURE 5

TOP VIEW OF CONTROL PANEL



MIS-354

NOTE: Rotate thumbwheel up to open; down to close.

9. Connect leads with fork terminal to corresponding points on terminal strip to terminals C and G. (See wiring diagram, Figure 6 below or on ventilator.)
10. Close control panel cover
11. Replace left filter support, filter and four (4) screws in condenser grille.
12. Reinstall the blower access panel at top of unit and secure with sheet metal screws.
13. Ventilator Checkout
 - A. Remove mist eliminator to allow access to minimum position thumbwheel. (See Figures 4 & 5.)
 - B. Resupply power to unit.
 - C. Energize the evaporator blower by switching thermostat to the manual fan position with heat/cool in OFF position.
 - D. Ventilator should open to the position set by position adjustment thumbwheel. Cycle position adjustment thumbwheel to full open through full close. Observe damper blade operation throughout travel to assure free, unobstructed movement. (See Figure 5.)
 - E. Adjust position adjustment thumbwheel until desired blade setting is reached with power applied to unit. See Tables 1 through 3 for required blade setting versus ventilator air.
 - F. De-energize evaporator blower. Damper blade should close.
 - G. This completes ventilator checkout.

14. Replace mist eliminator. Be sure it is installed with the drain holes to the bottom.
15. Remove blank off plate or barometric fresh air damper installed on service access door. Plug four (4) mounting holes with the plastic plugs provided with the ventilator.
16. Replace service access panel.
17. Ventilator is now ready for operation.

BLADE ADJUSTMENT FOR DESIRED VENTILATOR AIR

The amount of ventilation air supplied by the commercial room ventilator is dependant on four (4) factors.

1. Return air duct static pressure drop.
2. Supply air duct static pressure drop.
3. Indoor blower motor speed.
4. Damper blade open position setting.

To determine the amount of fresh air that will be supplied to the structure first determine the pressure drops of the supply and return air ducts. For free blow application with return air filter grille and supply grille assume .05 supply static, .10 return static. See application Table 3.

Determine on what speed the evaporator motor is running.

Refer to the tables on the following pages to determine the blade setting necessary to achieve the ventilation air required at the supply and return static duct pressures drops that are applicable.

FIGURE 6

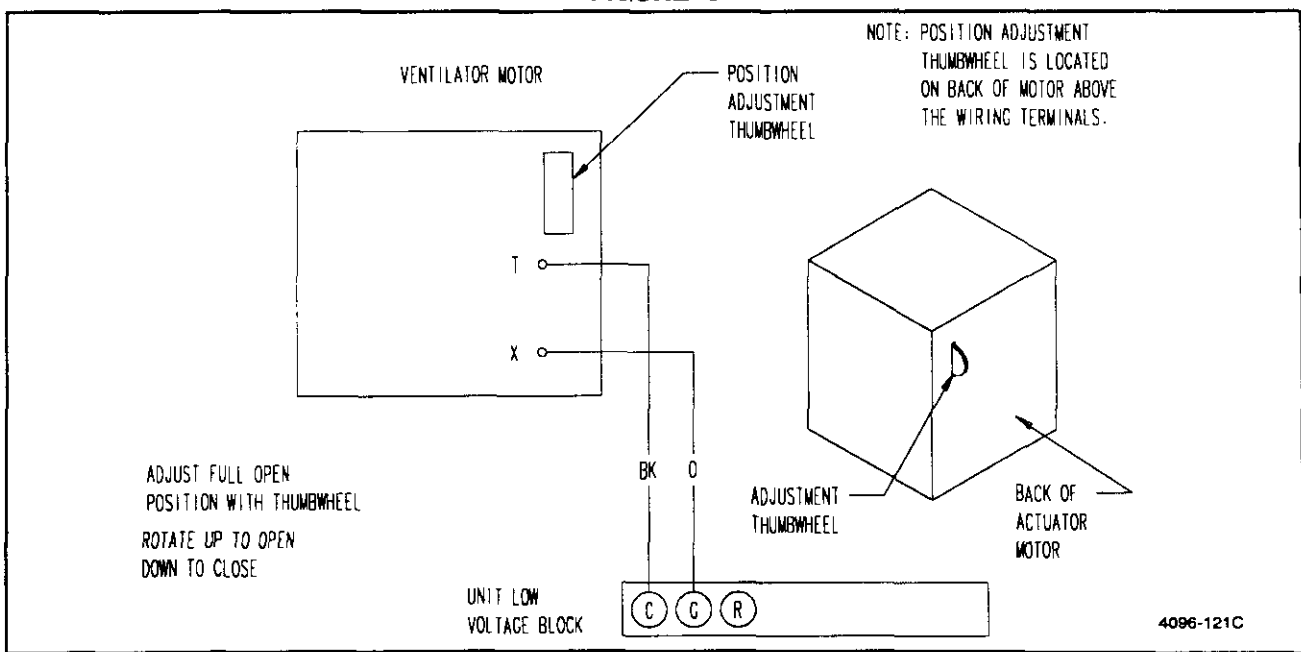

**COMMERCIAL ROOM VENTILATOR – CRV-5
VENTILATION AIR WITH DUCTED SYSTEM**

TABLE 1

0.00 SUPPLY AIR STATIC

HIGH SPEED		Ventilation Air (CFM)						
Damper Position	A	175	260	350	390	430	490	550
	B	325	385	450	495	540	590	645
	C	480	515	550	600	650	695	740
	D	630	660	690	720	750	785	820
	E	780	805	830	840	850	875	900
Return Static Pressure		.00	.05	.10	.15	.20	.25	.30

0.20 SUPPLY AIR STATIC

HIGH SPEED		Ventilation Air (CFM)						
Damper Position	A	175	260	350	390	430	490	550
	B	325	385	450	495	540	590	645
	C	480	515	550	600	650	695	740
	D	630	660	690	720	750	785	820
	E	780	805	830	840	850	875	900
Return Static Pressure		.00	.05	.10	.15	.20	.25	.30

0.30 SUPPLY AIR STATIC

HIGH SPEED		Ventilation Air (CFM)						
Damper Position	A	185	255	330	380	430		
	B	320	375	435	485	535		
	C	460	500	540	590	640		
	D	600	625	655	690	730		
	E	745	755	770	795	820		
Return Static Pressure		.00	.05	.10	.15	.20	.25	.30

0.40 SUPPLY AIR STATIC

HIGH SPEED		Ventilation Air (CFM)						
Damper Position	A	195	255	315				
	B	320	365	420				
	C	440	480	525				
	D	575	595	650				
	E	710	710	715				
Return Static Pressure		.00	.05	.10	.15	.20	.25	.30

TABLE 1 (continued)

LOW SPEED		0.00 SUPPLY AIR STATIC						
		Ventilation Air (CFM)						
Damper Position	A	200	260	320	380	440		
	B	295	345	395	460	525		
	C	390	430	470	540	610		
	D	520	550	585	630	680		
	E	650	675	700	725	750		
Return Static Pressure		.00	.05	.10	.15	.20	.25	.30

LOW SPEED		0.10 SUPPLY AIR STATIC						
		Ventilation Air (CFM)						
Damper Position	A	185	250	310	375	435		
	B	280	335	385	450	515		
	C	380	425	465	530	595		
	D	505	540	570	620	665		
	E	635	660	680	710	740		
Return Static Pressure		.00	.05	.10	.15	.20	.25	.30

LOW SPEED		0.20 SUPPLY AIR STATIC						
		Ventilation Air (CFM)						
Damper Position	A	180	240	300	365	430		
	B	275	325	380	445	510		
	C	370	415	465	530	595		
	D	490	525	560	610	655		
	E	615	635	660	690	720		
Return Static Pressure		.00	.05	.10	.15	.20	.25	.30

**NON-DUCTED BLOW APPLICATION VENTILATION AIR
WITH RETURN AIR FILTER GRILLE AND SUPPLY AIR GRILLE**

TABLE 2

		Ventilation Air (CFM)	
		High Speed	Low Speed
Damper Posiiton	A	350	315
	B	460	390
	C	575	465
	D	720	575
	E	870	690

**CRV-5 TOTAL DELIVERED AIR
WH602, WA602 and WL602**

TABLE 3

HIGH SPEED BLOWER

		TOTAL DELIVERED AIR (CFM)					
Damper Position	Close	2040	1955	1870	1775	1680	1585
	A	2030	1950	1870	1775	1680	1585
	B	1995	1910	1830	1740	1645	1550
	C	1960	1875	1790	1700	1610	1520
	D	1885	1750	1615	1575	1535	1490
	E	1810	1725	1640	1550	1460	1370
Total Static Pressure		.00	.10	.20	.30	.40	.50

LOW SPEED BLOWER

		TOTAL DELIVERED AIR (CFM)					
Damper Position	Close	1510	1480	1450	1420	1385	1350
	A	1490	1460	1430	1400	1370	1340
	B	1465	1435	1410	1380	1350	1320
	C	1440	1415	1390	1360	1330	1300
	D	1405	1375	1350	1320	1290	1260
	E	1370	1340	1310	1280	1255	1230
Total Static Pressure		.00	.05	.10	.15	.20	.25

CRV-5 TOTAL DELIVERED AIR
WH482, WA482 and WL482
WH421, WA421 and WL421

TABLE 3 (continued)

HIGH SPEED BLOWER		TOTAL DELIVERED AIR (CFM)					
Damper Position	Close	1865	1775	1685	1585	1485	1485
	A	1860	1770	1685	1585	1485	1385
	B	1850	1755	1660	1560	1460	1360
	C	1840	1740	1655	1555	1455	1355
	D	1770	1680	1590	1490	1390	1290
	E	1700	1610	1525	1425	1325	1225
Total Static Pressure		.00	.10	.20	.30	.40	.50

LOW SPEED BLOWER		TOTAL DELIVERED AIR (CFM)					
Damper Position	Close	1560	1530	1500	1460	1425	1390
	A	1545	1515	1480	1445	1415	1380
	B	1530	1495	1460	1430	1400	1365
	C	1510	1485	1455	1420	1385	1350
	D	1480	1450	1420	1385	1345	1310
	E	1445	1415	1380	1345	1305	1270
Total Static Pressure		.00	.05	.10	.15	.20	.25

COMMERCIAL ROOM VENTILATOR – WA, WH AND WL SERIES

FEATURES

- One piece construction – easy to install with no mechanical linkage adjustment required.
- Exhaust air damper – built in with positive closed position. Provides exhaust air capability to prevent pressurization of tight buildings.
- Actuator motor – 24 volt, power open, spring return with built in torque limiting switch.
- Provides up to 75 percent of outside air.

COMMERCIAL ROOM VENTILATOR SEQUENCE OF OPERATION

On a call for blower operation, CRV opens to full open position as set by minimum position potentiometer. See Figure 7.

FIGURE 7

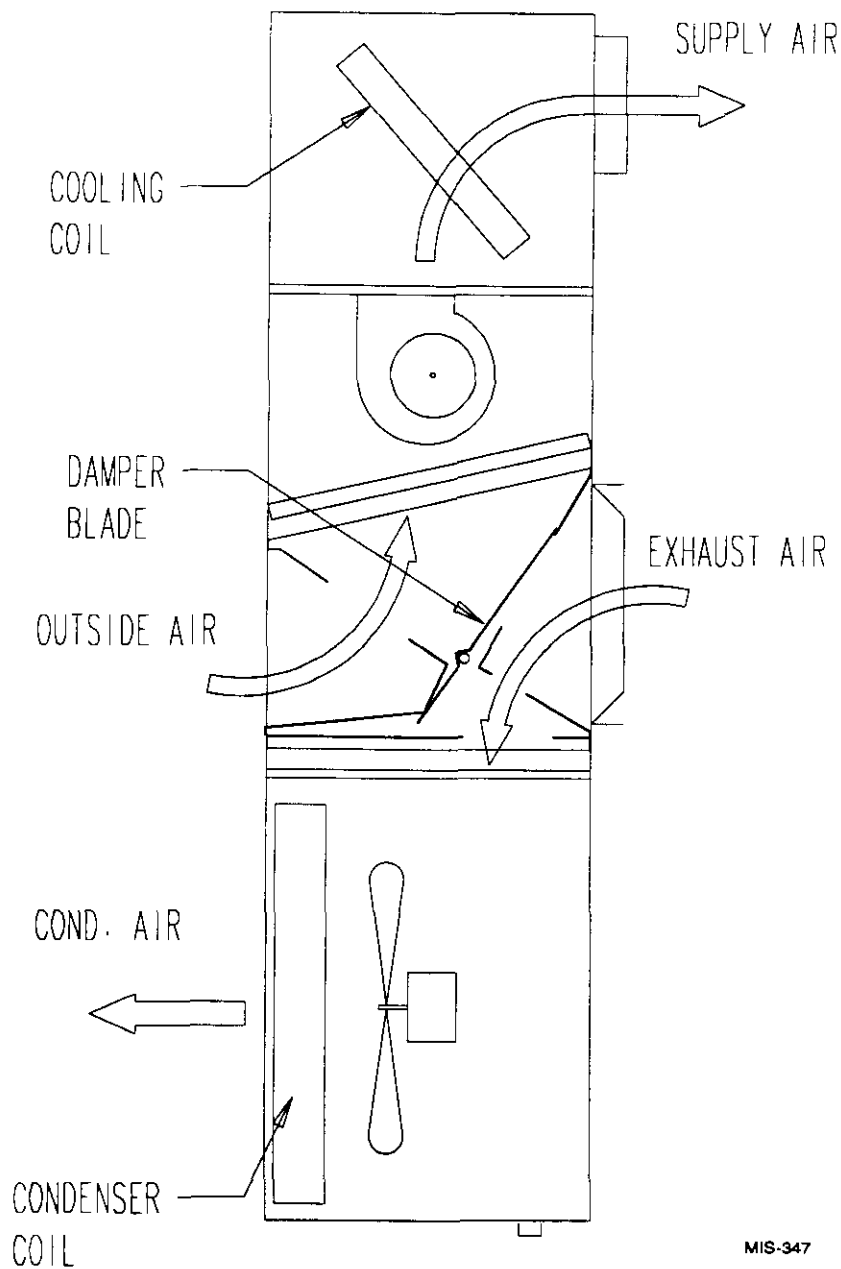

MIS-347

A call for cooling cycles the compressor, and dampers remain in the ventilation mode. On loss of blower operation, CRV closes fully. See Figure 8.

FIGURE 8

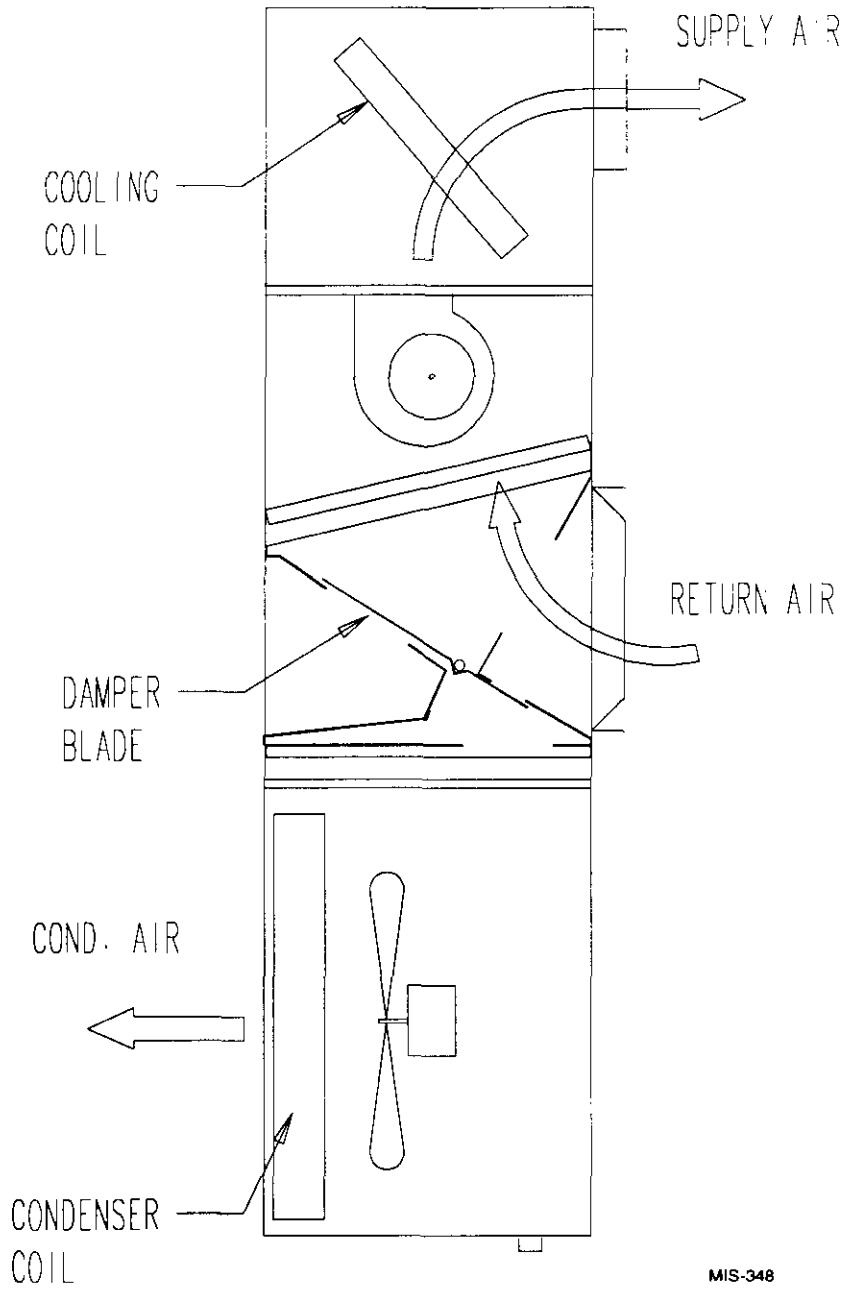

MIS-348

