

INSTALLATION INSTRUCTIONS

**MODEL
MFAD-5**

MOTORIZED FRESH AIR DAMPER

DATE: 04-12-94

MANUAL 2100-224 REV. B
SUPERSEDES REV. A
FILE VOL. III, TAB 19

TABLE OF CONTENTS

Description 1
Application 1
Installation. 3

Manufactured under U.S. patent number 5,301,744.
Other patents pending.

COPYRIGHT APRIL, 1994
BARD MANUFACTURING COMPANY
BRYAN, OHIO USA 43506

DESCRIPTION

The motorized fresh air damper MFAD-5 is an internally mounted dampers designed to bring in up to 25% fresh air. The damper blade is powered by a 24 VAC motor with spring return on power loss. The damper is powered open anytime the unit blower motor is energized.

APPLICATION

The amount of outside fresh air brought into the structure is dependent on the supply and return duct static pressure present in the duct system. Refer to Page 2 for ventilation air that will be supplied at different duct static pressures.

For free blow applications with return air filter grill and supply grill use 0.00 supply air static pressure and 0.1 return air static pressure.

Suitable for
use with:

MFAD-5		
WA421-A	WB481-A	WB421LA
WA421-B	WB481-B	WB421LB
WA421-C	WB481-C	WB421LC
WA421-E		
WA421-F	WA601-A	WB481LA
	WA601-B	WB481LB
WB421-A	WA601-C	WB481LC
WB421-B	WA601-E	
WB421-C	WA601-F	WB601LA
		WB601LB
		WB601LC
WA481-A	WB601-A	
WA481-B	WB601-B	
WA481-C	WB601-C	
WA481-E		
WA481-F		

MOTORIZED FRESH AIR DAMPER
MFAD-5

HIGH SPEED

	Supply Air ESP	Ventilation Air (CFM)				
	.00	180	265	350	420	490
	.20	175	255	335	410	490
	.40	165	245	325	405	490
Return Air Static Pressure		.00	.05	.10	.15	.20

LOW SPEED

Ventilation Air (CFM)	125	225	330	415	500
Return Air Static Pressure	.00	.05	.10	.15	.20

INSTALLATION

- STEP 1. Disconnect all power to wall mount unit before installing MFAD.
- STEP 2. Remove service door. (See Figure 1) Remove fresh air damper or blank off plate if installed on service door. Remove 4 screws from top of front condenser grille. (See Figure 3A)
- STEP 3. The "exhaust cover plate" must be in place when an MFAD-5 is installed. (See Figure 2)
- STEP 4. Install MFAD with notch in front lip of MFAD centered over hole in condenser partition. (See Figure 3A)
- STEP 5. Position MFAD with front lip over condenser partition and front grille. (See Figure 3B) This is important to insure proper drainage of any water entering damper assembly.
- STEP 6. Use a self drilling screw through hole provided in left mounting flange to secure MFAD in position.
- STEP 7. Route wires as shown in Figure 3A into unit low voltage terminal strip area.
- STEP 8. Connect black wire to C terminal of low voltage block. Connect red wire to G terminal of low voltage block. See wall mount low voltage connection diagram in the unit installation instructions for wiring diagram.
- STEP 9. Check MFAD for proper operation. MFAD should open whenever the blower is energized.
- STEP 10. Replace 4 screws in front condenser grille and replace service door. Plug 4 holes in service door with plastic plugs provided.

FIGURE 1

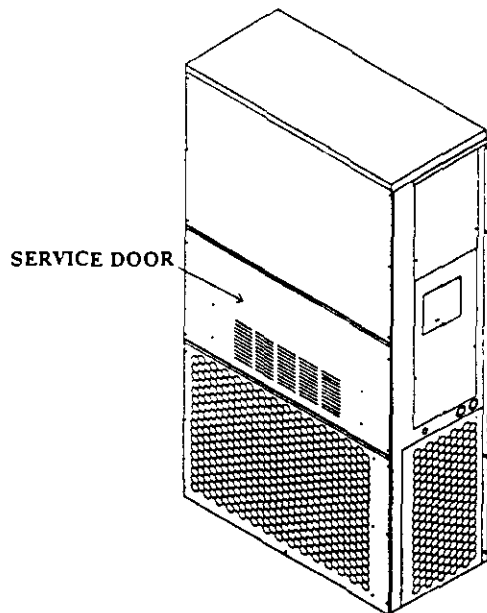

FIGURE 2

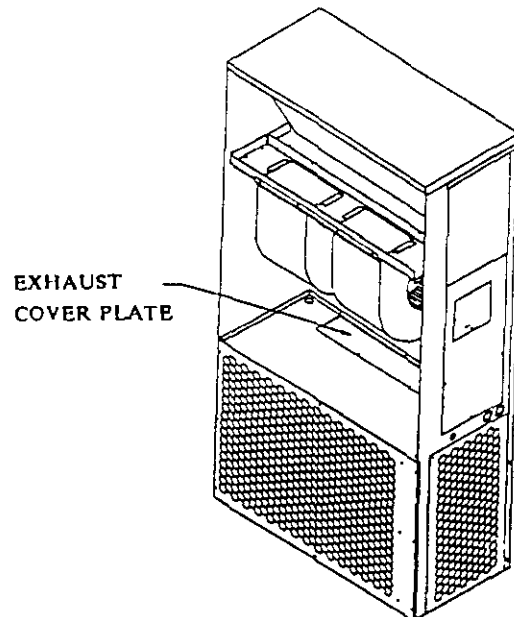

FIGURE 3A

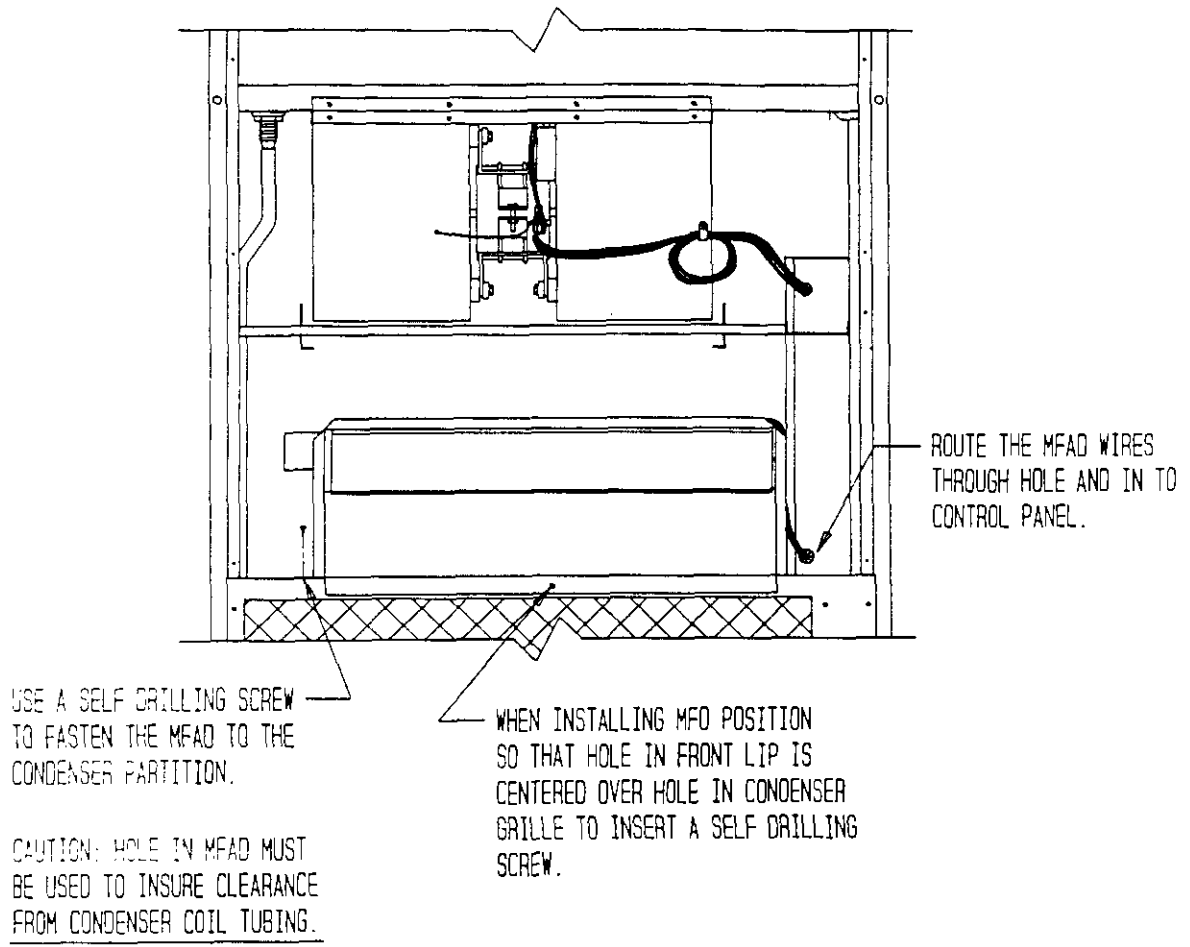

FIGURE 3B

