INSTALLATION INSTRUCTIONS

OPTIONAL CONTROL MODULE KITS FOR USE WITH 1/2 – 5 TON WALL MOUNTED PACKAGED AIR CONDITIONERS AND HEAT PUMPS

CMH-3	Low Pressure Control A/C 1-1/2 – 3-1/2 Ton
CMA-5	Compressor Time Delay Relay A/C
CMA-6	Low Ambient Control A/C
CMH-7	Low Ambient Control H/P
CMH-9	Low Pressure Control + Low Ambient Control H/P 1-1/2 – 3-1/2 Ton
CMA-10A	Dual Pressure Control + Time Delay Relay A/C 1-1/2 – 3-1/2 Ton
CMA-12	Low Ambient Control + Time Delay Relay A/C 1-1/2 – 3-1/2 Ton
CMA-13A	Dual Pressure Control + Low Ambient Control + Time Delay Relay A/C 1-1/2 – 3-1/2 Ton
CMH-14	Outdoor Thermostat Kit H/P
CMC-15	Start Kit (PTCR) 1-1/2 – 3-1/2 Ton
CMA-16	Low Pressure Control A/C 4 – 5 Ton
CMA-18	Low Pressure Control + Low Ambient Control A/C 4 – 5 Ton



Bard Manufacturing Company
Bryan, Ohio 43506

*Since 1914...Moving ahead, just as
planned.*

Manual No.: 2100-226A
Supersedes: 2100-226
File: Vol III Tab 19
Date: 10-25-99

SUITABLE FOR USE WITH

Models	WA/WL181-A WA/WL241-A	WA/WL241-B		WA/WL251-A,-B,-C	WH182-A WH241-A	WH241-B,-C	
	WA/WL301-A WA/WL361-A	WA/WL301-B WA/WL361-B	WA/WL301-C WA/WL361-C	WA/WL371-A,-B,-C	WH301-A WH361-A	WH301-B,-C WH361-B,-C	
	WA/WL421-A	WA/WL421-B	WA/WL421-C	WA/WL482-A,-B,-C WA/WL602-A,-B,-C	WH421-A	WH421-B,-C	WH482-A,-B,-C WH602-A,-B,-C
CMH-3					X	X	X
CMA-5	X	X	X				
CMA-6	X	X	X	X			
CMH-7					X	X	X
CMH-9					X	X	X
CMA-10A	X	X	X				
CMA-12	X	X	X				
CMA-13A	X	X	X				
CMH-14					X	X	X
CMC-15	X	X	X		X		X
CMA-16				X			
CMA-18				X			



Bard Manufacturing Company
Bryan, Ohio 43506

INSTALLATION INSTRUCTIONS

CMH-3

LOW PRESSURE CONTROL

DESCRIPTION

The CMH-3 is a field installable low pressure control. The CMH-3 consists of:

1. Installation Instructions 7960-233A
2. Control Assembly 910-1095
3. Low Pressure Control 1804-0107
4. Unit Label 7961-312-0012

For use with all WH182 – WH602 Hi-Boy Wall Mount Heat Pumps.

INSTALLATION INSTRUCTIONS

Disconnect all power to unit. Remove control panel inner and outer covers, and right side condenser inlet grille. Circled numbers on Figure 2 correspond to installation instruction steps. Dashed lines indicate that a wire has been disconnected from this terminal and reconnected to another terminal.

Use Figure 2 for WH182 to WH361.

Use Figure 3 for WH421 to WH602.

- Step 1. Mount control assembly 910-1095 into control panel as shown with screws provided. See Figure 2 or 3, Step 1.
- Step 2. Disconnect blue high pressure control wire from heat pump control terminal LO and reconnect to terminal #1 of control assembly 910-1095. Route wires through wire holder as shown in Figure 2 or 3, Step 2.
- Step 3. Connect the blue wire from control assembly 910-1095 to LO terminal of the heat pump control. See Figure 2 or 3, Step 3.
- Step 4. Route low pressure control wires up through the bushing in the bottom of the control panel. Replace sealing compound after routing wires through the bushing. Route the wires through the wire holders in the control panel as shown in Figure 4. Connect the low pressure control wires between the terminals #1 and #3 of control assembly 910-10-9. See Figure 2 or 3, Step 4.
- Step 5. Connect the yellow wire from control assembly 910-1095 to Y terminal of the compressor contactor coil. This is the side of the contactor coil that the yellow wire is attached to. See Figure 2 or 3, Step 5.
- Step 6. Connect the black wire from control assembly 910-1095 to C terminal of the compressor contactor coil. This is the side of the contactor coil that the black wire is attached to. See Figure 2 or 3, Step 6.
- Step 7. Remove service port cap on the suction line. Install the low pressure switch on the suction line. Check for pressure at the flare tee dill valves after installation to insure that the dill valve in the unit service port was depressed by the flare tee connector. Check for leaks at the flare tee connectors. Replace service port cap on the flare tee service port and tighten. See Figure 4.
- Step 8. Recheck all wiring. See Figure 1. Check for proper operation of the unit by energizing in cooling mode. Run for five minutes. Unit should not go into lockout.
- Step 9. Apply "This unit equipped with CMH-3 control module" label to the inside of the inner control panel cover above the wiring diagram.
- Step 10. Replace all panels and covers. This completes installation.

FIGURE 1

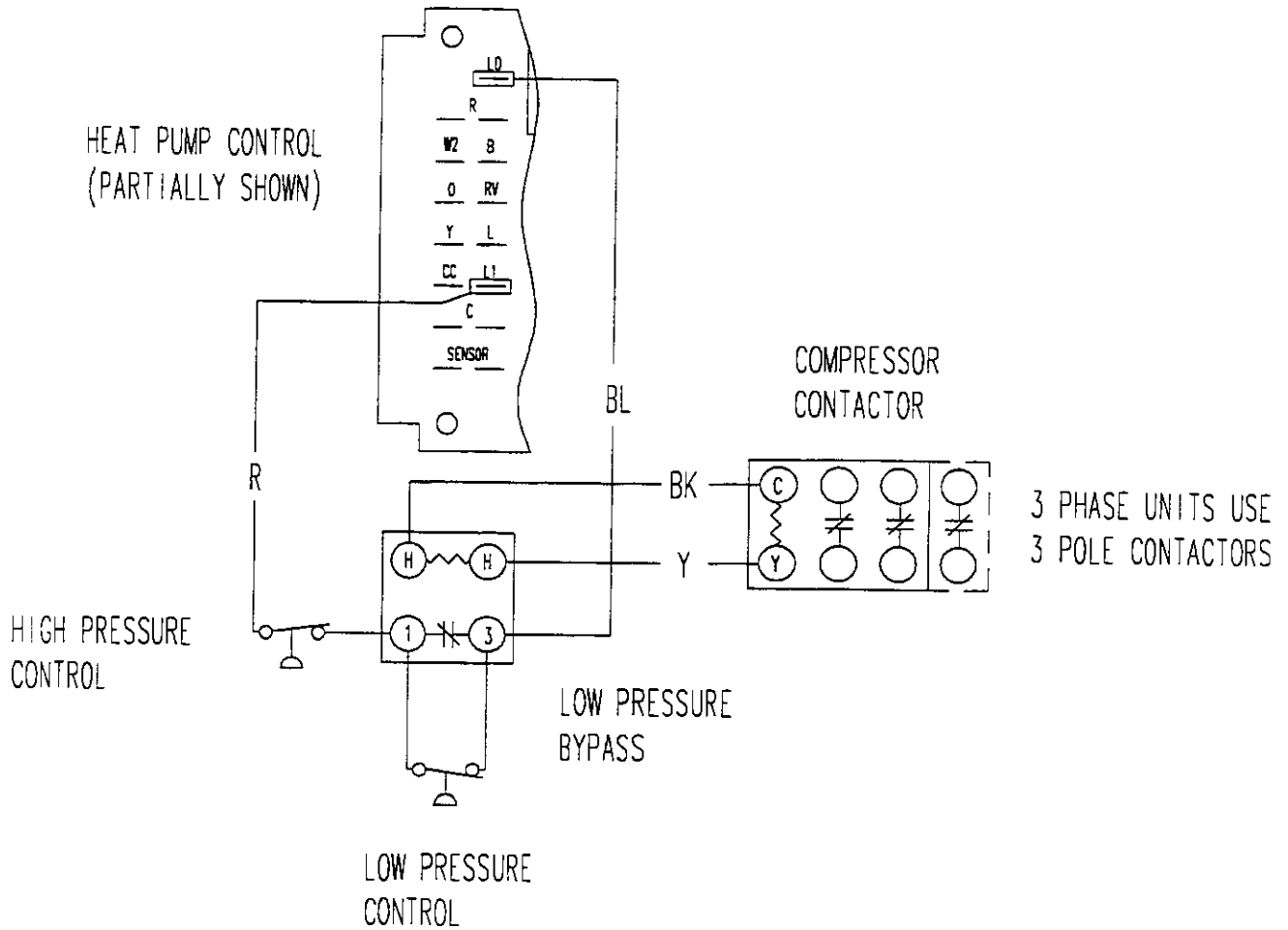

MIS-304

FIGURE 2

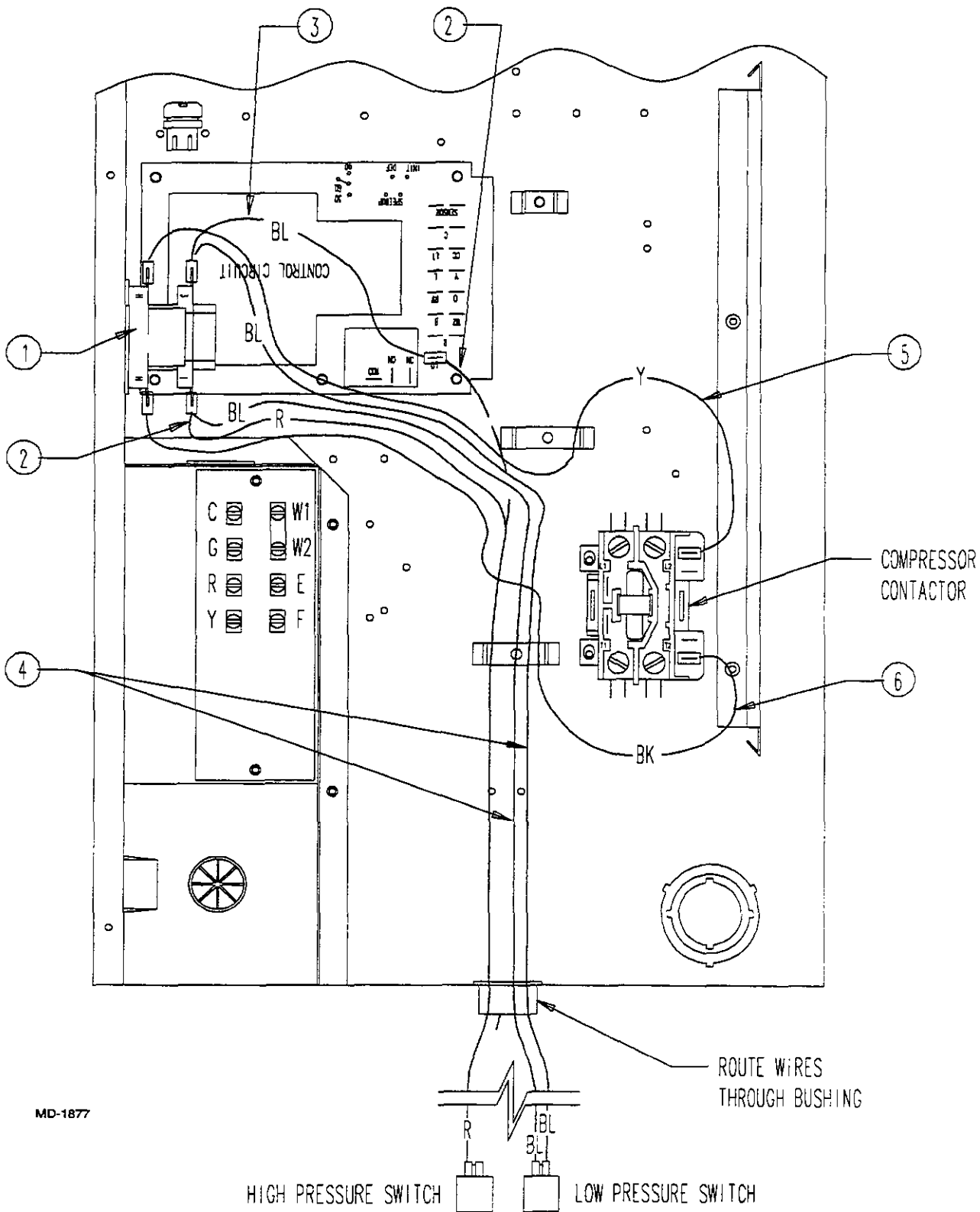

MD-1877

FIGURE 3

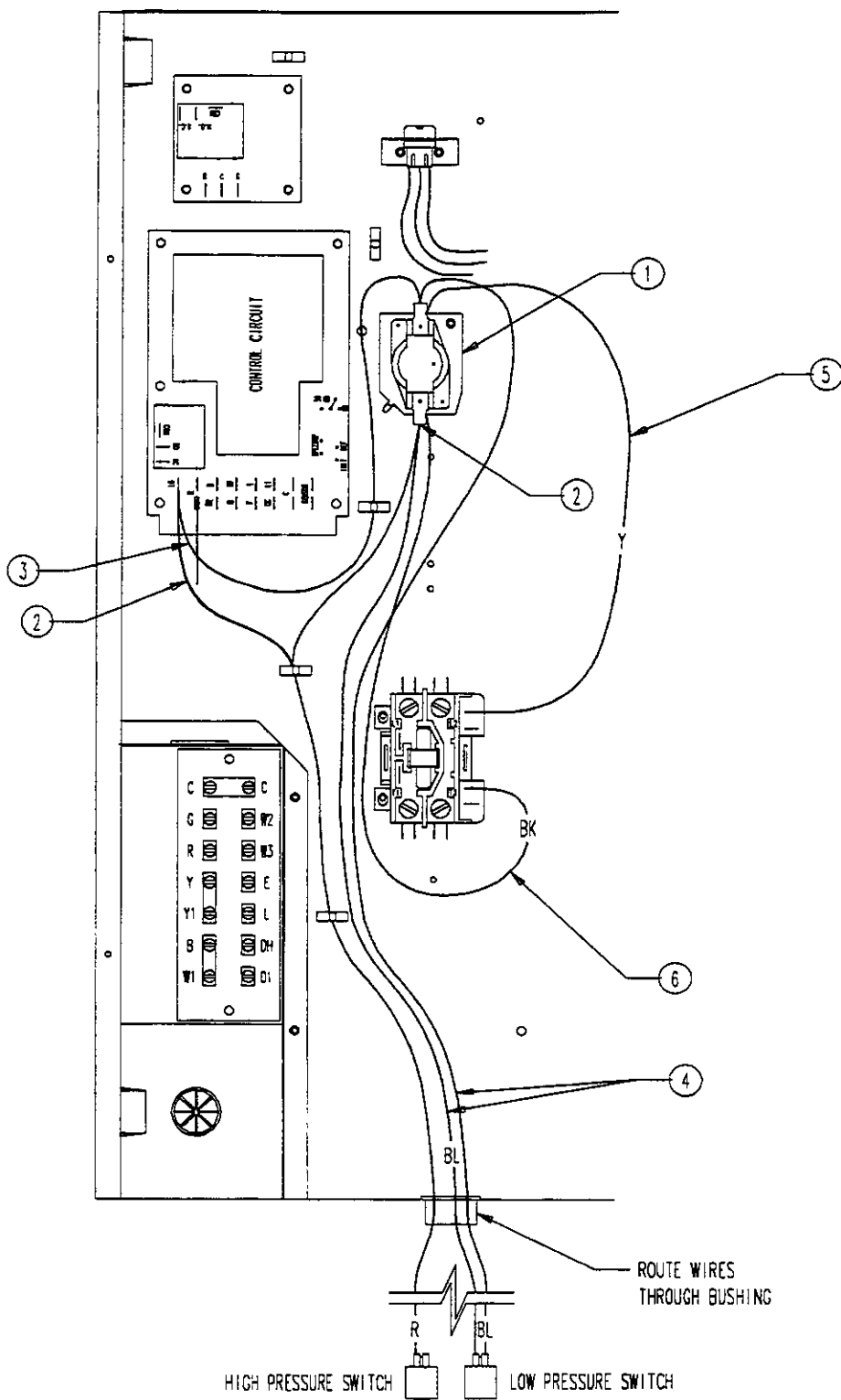

MIS-1391

FIGURE 4

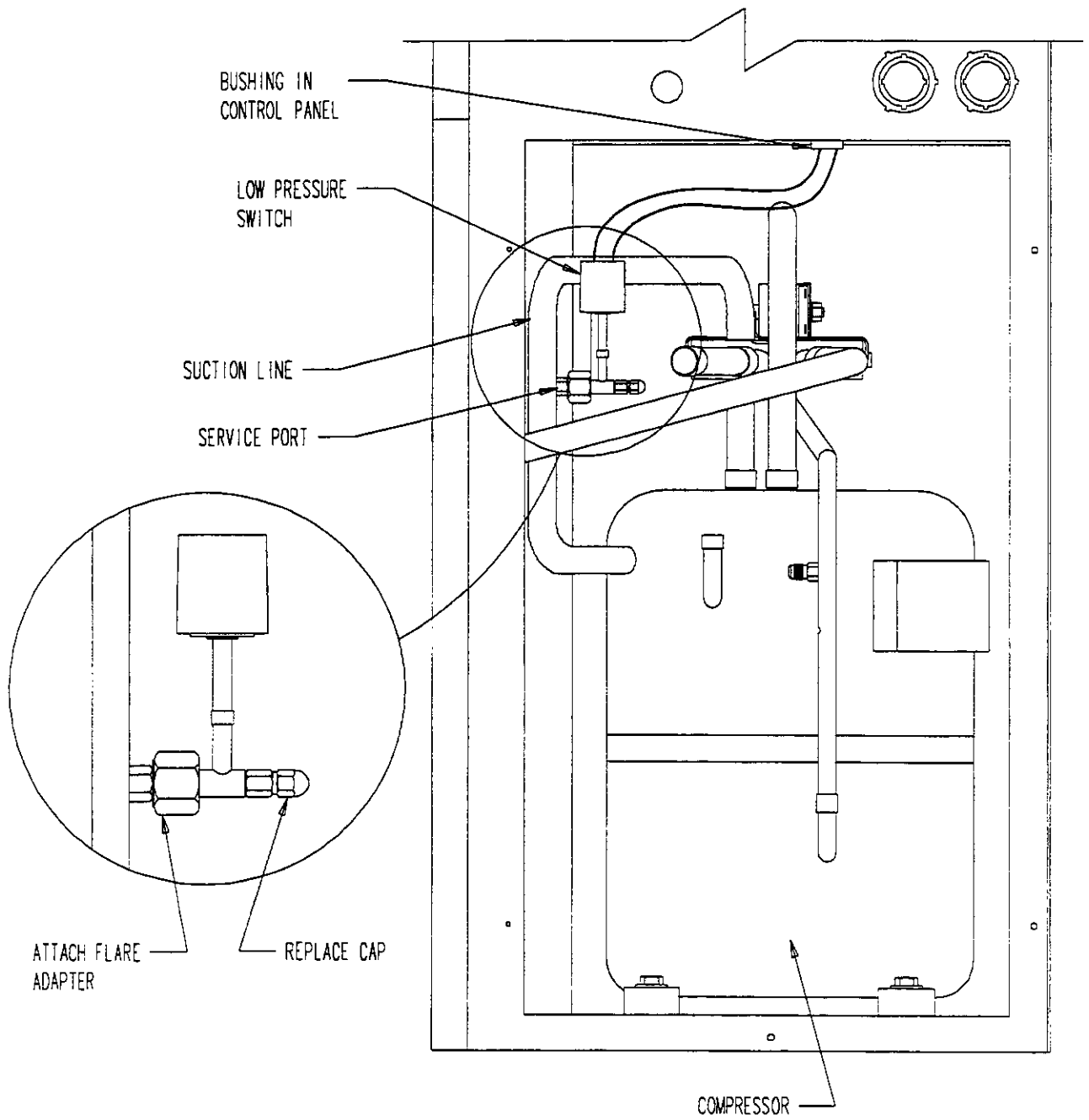

MIS-1392



Bard Manufacturing Company
Bryan, Ohio 43506

INSTALLATION INSTRUCTIONS

CMA-5

COMPRESSOR TIME DELAY RELAY

DESCRIPTION

The CMA-5 is a field installable five (5) minute delay on break compressor time delay relay. The CMA-5 consists of:

1. Installation Instructions 7960-235
2. Compressor time delay relay 8201-050
3. Mounting screw
4. Unit Label 7961-312-0002

INSTALLATION INSTRUCTIONS

Disconnect all power to unit. Remove control panel inner and outer covers. Circled numbers on Figure 2 correspond to installation instruction steps. Dashed lines indicate that a wire has been disconnected from this terminal and reconnected to another terminal.

Step 1. Mount compressor TDR in position shown in Figure 2, Step 1 with screw provided.

- Step 2. Disconnect yellow low voltage (Y) wire at the compressor contactor coil and reconnect to the Y1 or #3 terminal of the TDR. See Figure 2, Step 2.
- Step 3. Connect yellow wire from terminal (Y) of the TDR to the (Y) terminal of the compressor contactor coil. This is the terminal that the wire was removed from in Step 2. Route wires through wire holder as shown in Figure 2, Step 3.
- Step 4. Recheck wiring. Refer to Figure 1. Energize unit. Compressor should start. Remove power and reapply. Compressor should not start until the 5 minute time delay has expired.
- Step 5. Apply "This unit equipped with CMA-5 control module" label to inside of the inner control panel cover above wiring diagram..
- Step 6. Replace all panel and covers. This completes installation.

FIGURE 1

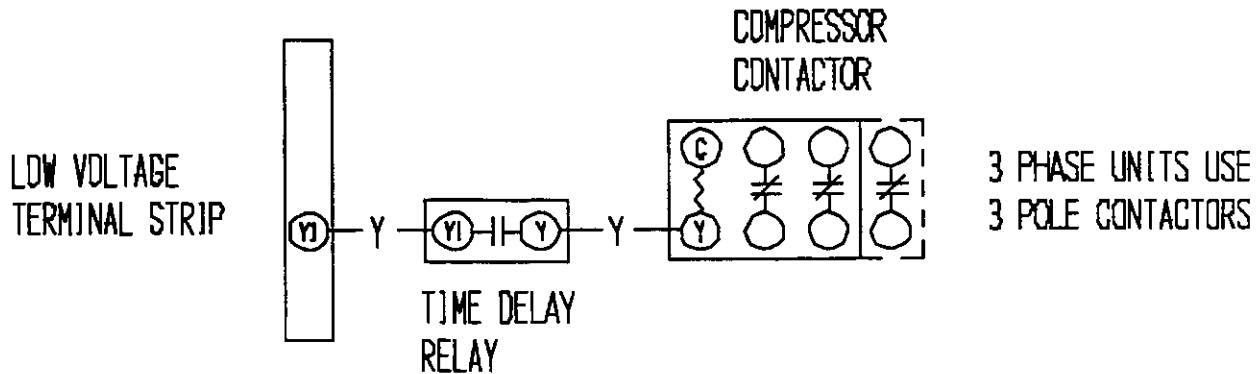

MIS-379

FIGURE 2

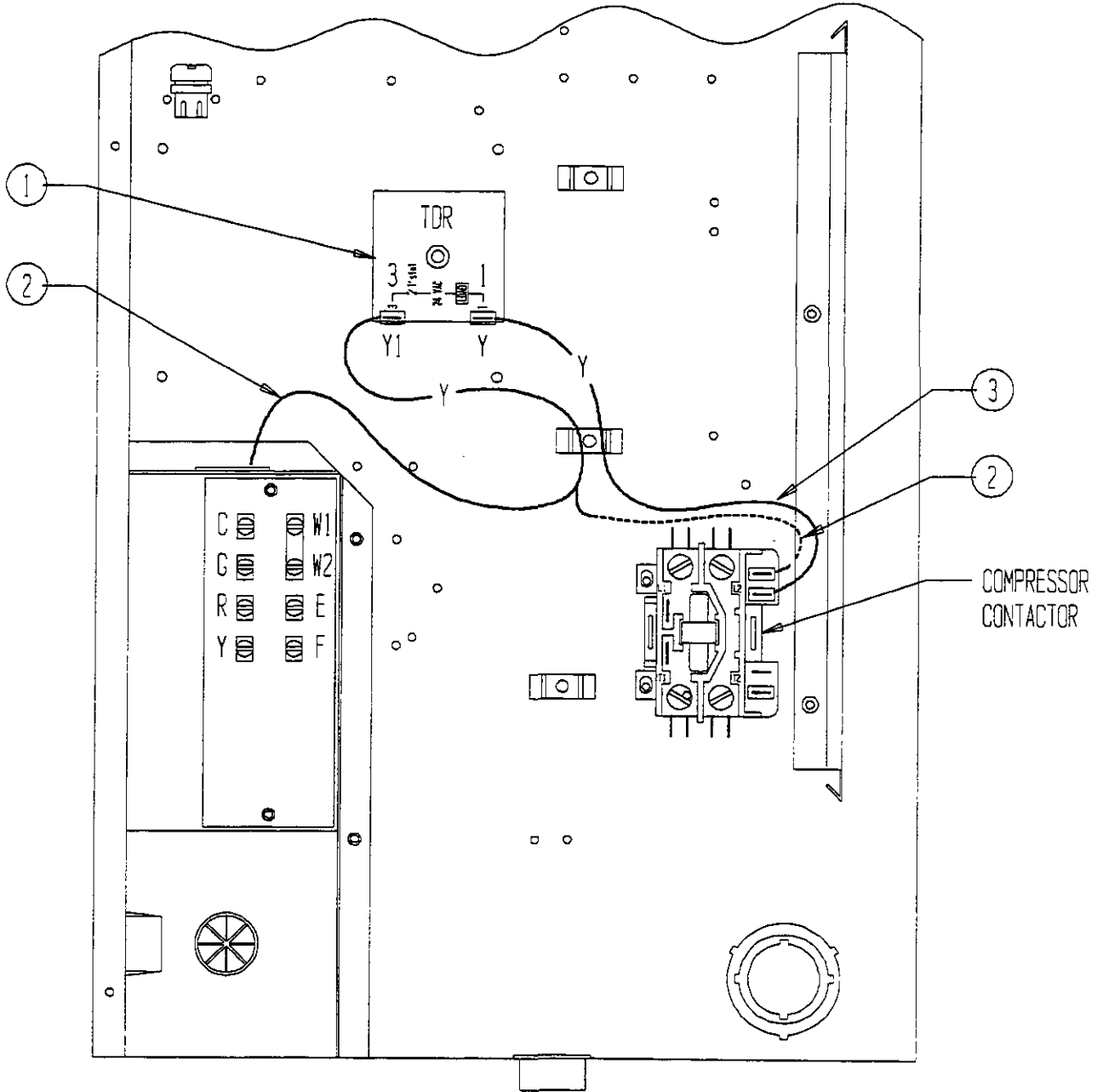

MD-1850



Bard Manufacturing Company
Bryan, Ohio 43506

INSTALLATION INSTRUCTIONS

CMA-6

LOW AMBIENT FAN CYCLING CONTROL

DESCRIPTION

The CMA-6 is a field installable low ambient fan cycling control. The CMA-6 consists of:

1. Installation Instruction 7960-236B
2. Low Ambient Control (LAC) 1804-0108
3. Terminal Block 8607-016
4. CMA-6 unit label 7961-312-003

For use with all WAWL series, P series and WAG series air conditioners.

INSTALLATION INSTRUCTIONS FOR WAWL SERIES AND P SERIES

Disconnect all power to unit. Remove control panel inner and outer covers, and right side condenser inlet grille. Circled numbers on Figure 2 (3 or 4) correspond to installation instruction steps. Dashed lines indicate that a wire has been disconnected from this terminal and reconnected to another terminal.

Use Figure 2 for WA182 through WA371

Use Figure 3 for WA421 through WA721

Use Figure 4 for P series.

- Step 1. Mount terminal block in position shown in Figure 2, 3 or 4, Step 1.
- Step 2. Disconnect black high voltage outdoor motor lead from compressor contactor and reconnect to terminal block. Route wires through wire holder as shown in Figure 2, 3 or 4, Step 2.

Step 3. Route low ambient control wires up through the bushing in the bottom of the control panel. Replace sealing compound after routing wires through the bushing. Route the wires through the wire holders in the control panel as shown in Figure 2, 3 or 4. Connect the low ambient control wires between the terminal block and T2 of the compressor contactor. See Figure 2, 3 or 4, Step 3.

Step 4. Remove service port cap on discharge line. Install the low ambient control on the liquid line with the flare tee dill valve after installation to insure that the dill valve in the unit service port was depressed by the flare tee connector. Check for leaks at the flare tee connectors. Replace service port cap on the flare tee service port and tighten. See Figure 5.

Step 5. Check wiring. See Figure 1. Check for proper operation of the unit by energizing in cooling mode. The condenser fan motor should not run until the discharge pressure has exceeded 280 PSI. Should the discharge pressure fall below 180 PSI while running, the condenser fan motor will de-energize until the head pressure builds to 280 PSI.

Step 6. Apply "This unit equipped with CMA-6 control module" label to the inside of the control panel cover above the wiring diagrams.

Step 7. Replace all panels and covers. This completes installation.

FIGURE 1

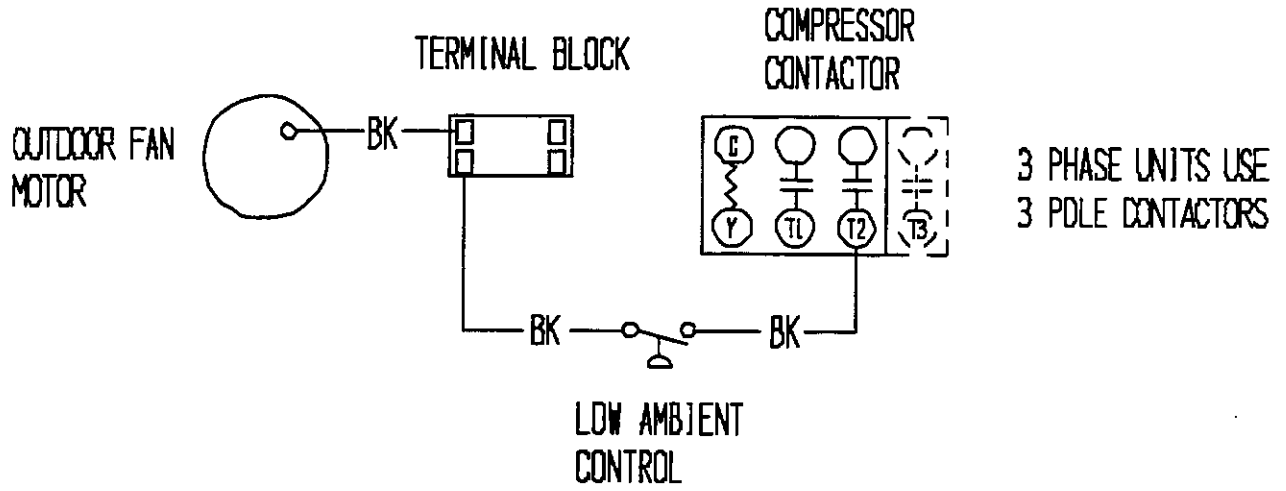

MIS-378

FIGURE 2

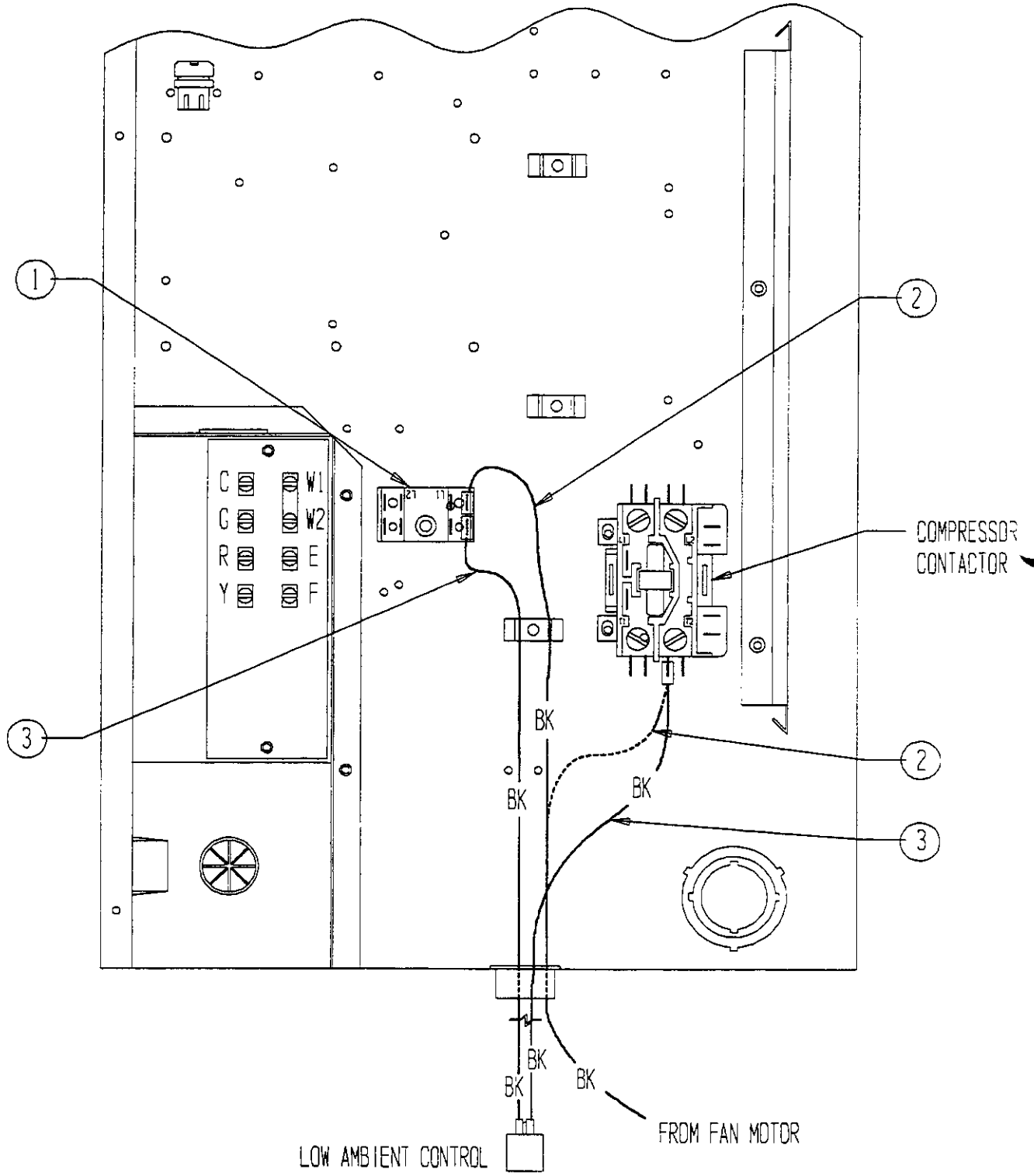
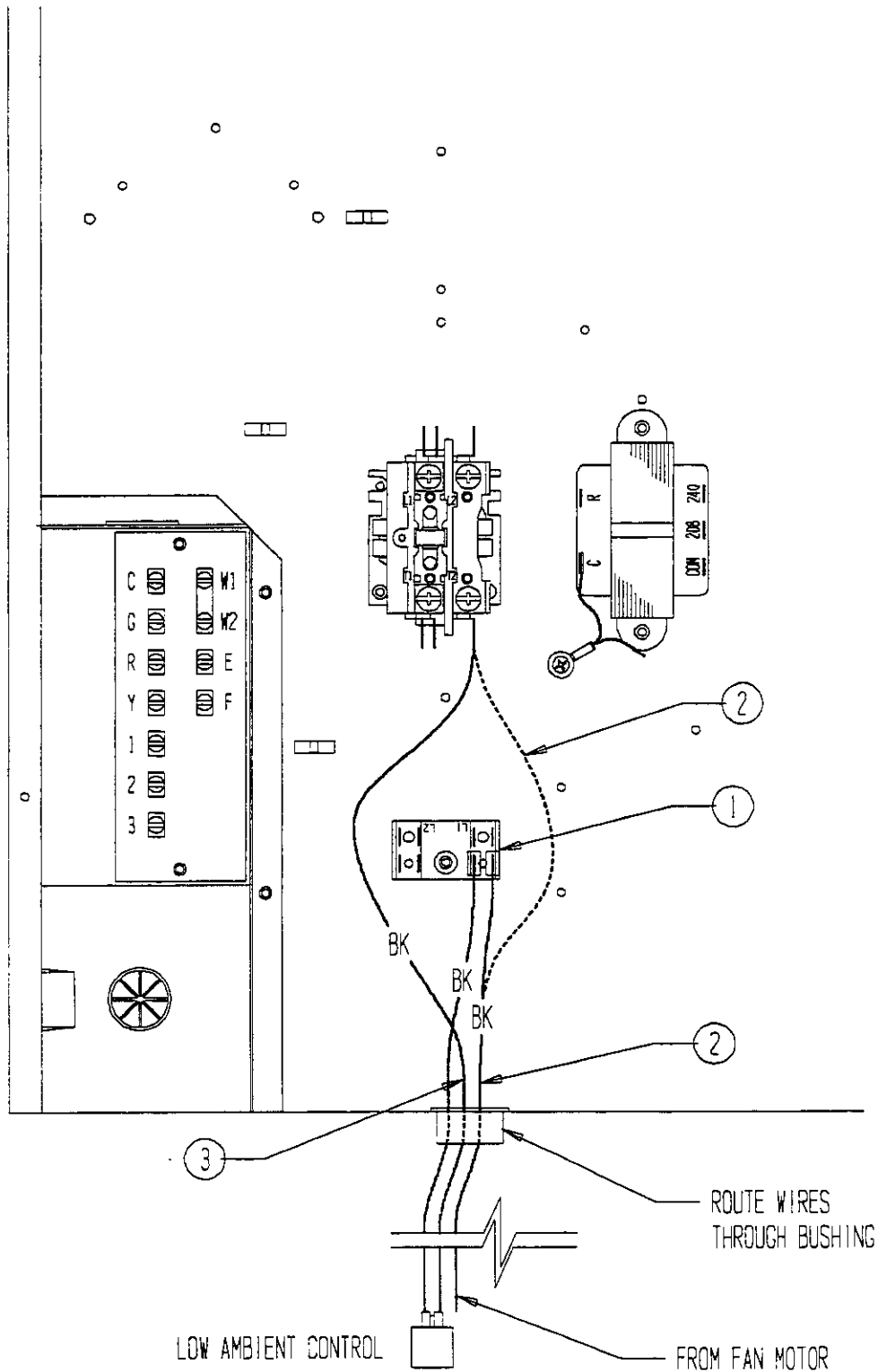
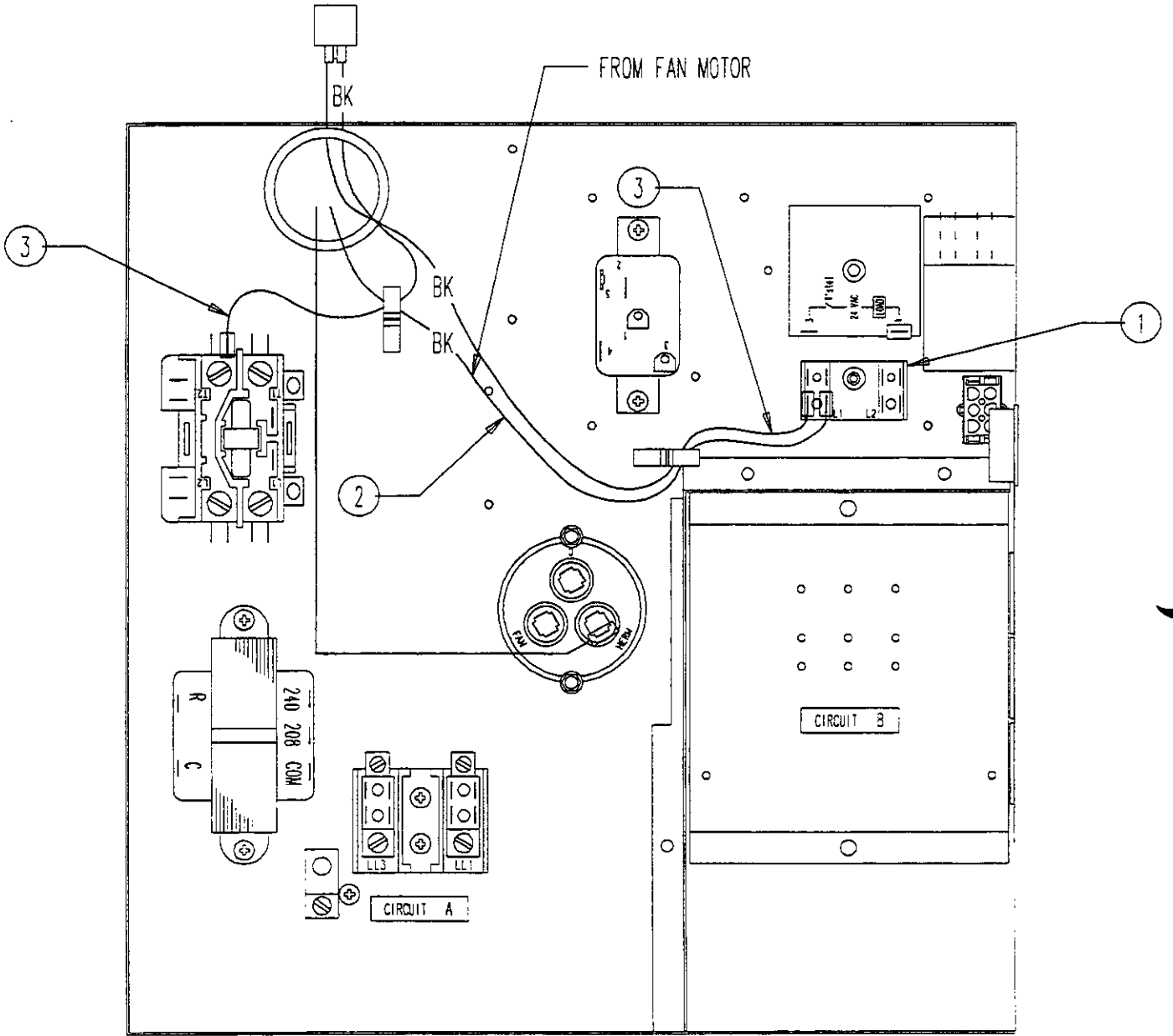

FIGURE 3



MIS1393

FIGURE 4
P SERIES



MIS-1394

FIGURE 5

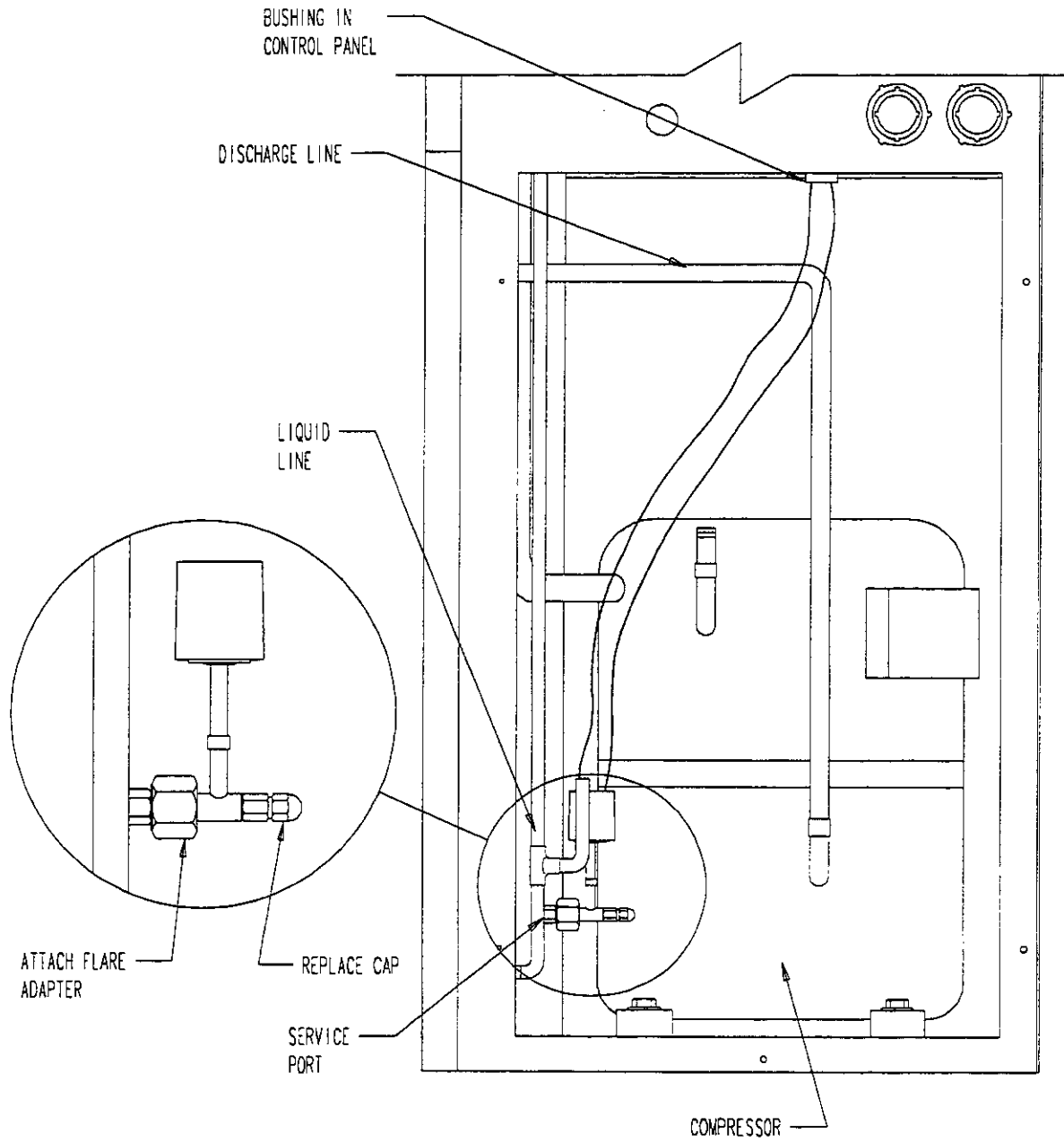

MIS-376

INSTALLATION INSTRUCTIONS

CMA-6

LOW AMBIENT FAN CYCLING CONTROL

INSTALLATION INSTRUCTIONS FOR WAG SERIES COMBINATION GAS/ ELECTRIC WALL MOUNTS™

Disconnect all power to unit. Remove control panel inner and outer covers, and blower service door. Circled numbers on Figure 6 correspond to installation instruction steps. Dashed lines indicate that a wire has been disconnected from this terminal and reconnected to another terminal.

- Step 1. Mount terminal block in position as shown in Figure 6, Step 1.
- Step 2. Disconnect black high voltage outdoor motor lead from compressor contactor and reconnect to terminal block. Route wires through wire holder as shown in Figure 6, Step 2.
- Step 3. Remove condenser fan motor snap bushing. Route low ambient control wire through snap bushing with condenser fan motor leads. Connect the low ambient control wires between the terminal block and T2 of the compressor contactor. Reinstall the snap bushing. See Figure 6, Step 3.
- Step 4. Remove service port cap on liquid line access next to the circulating air blower. Install the low ambient control on the liquid line with the flare tee adapter that is brazed to the low ambient control. Check for pressure at the flare tee dill valve after installation to insure that the dill valve on the unit service port was depressed by the flare tee connector. Replace the service port cap on the flare tee service port and tighten. See Figure 7.
- Step 5. Recheck wiring. See Figure 1. Check for proper operation of the unit by energizing in cooling mode. The condenser fan motor should not run until the liquid pressure has exceeded 280 PSI. Should the liquid pressure fall below 180 PSI while running, the condenser fan motor will de-energize until the liquid pressure builds to 280 PSI.
- Step 6. Apply "*This unit equipped with CMA-6 control module*" label to the inside of the control panel cover above the wiring diagrams.
- Step 7. Replace all panels and covers. This completes installation.

FIGURE 6

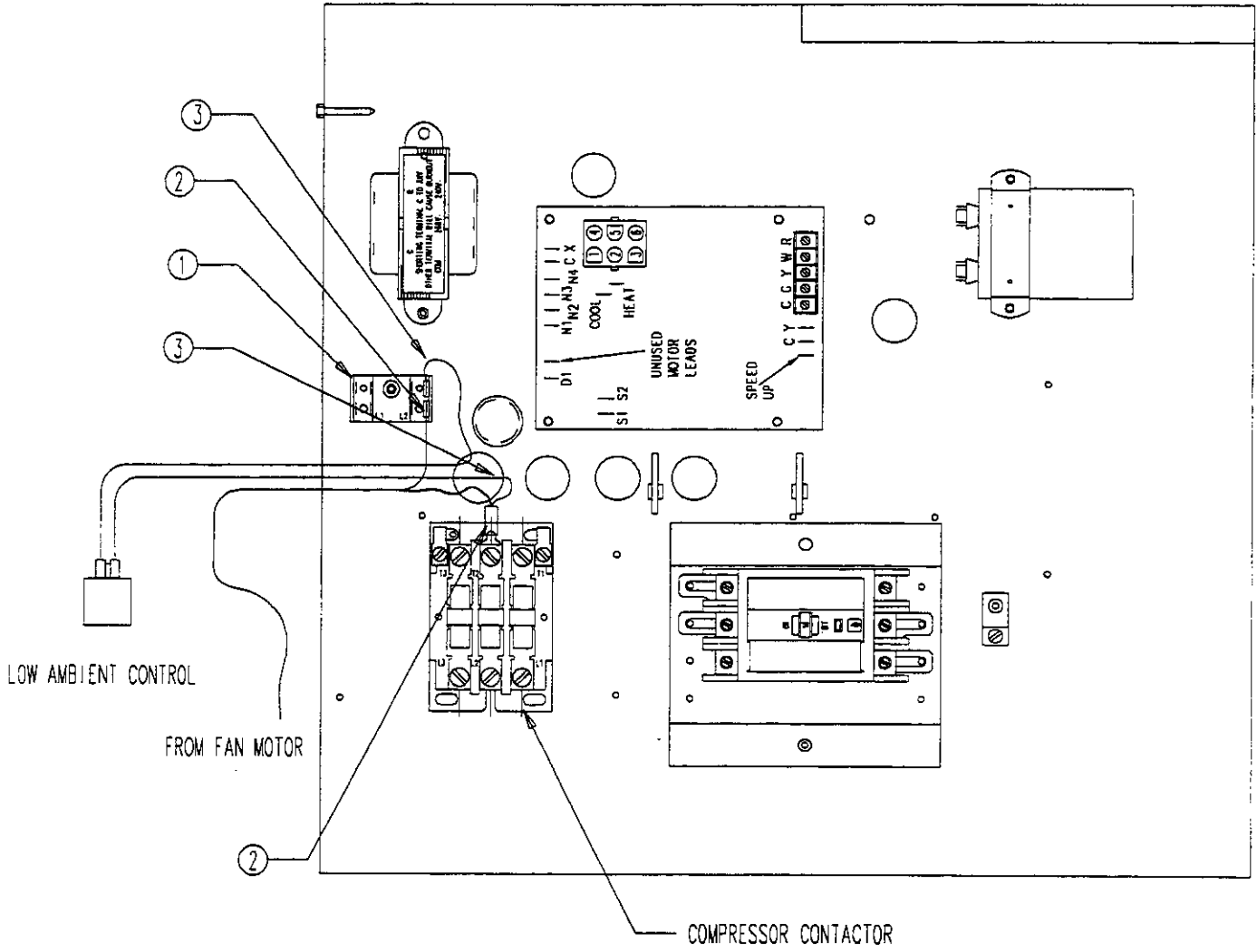

MIS-1071

FIGURE 7

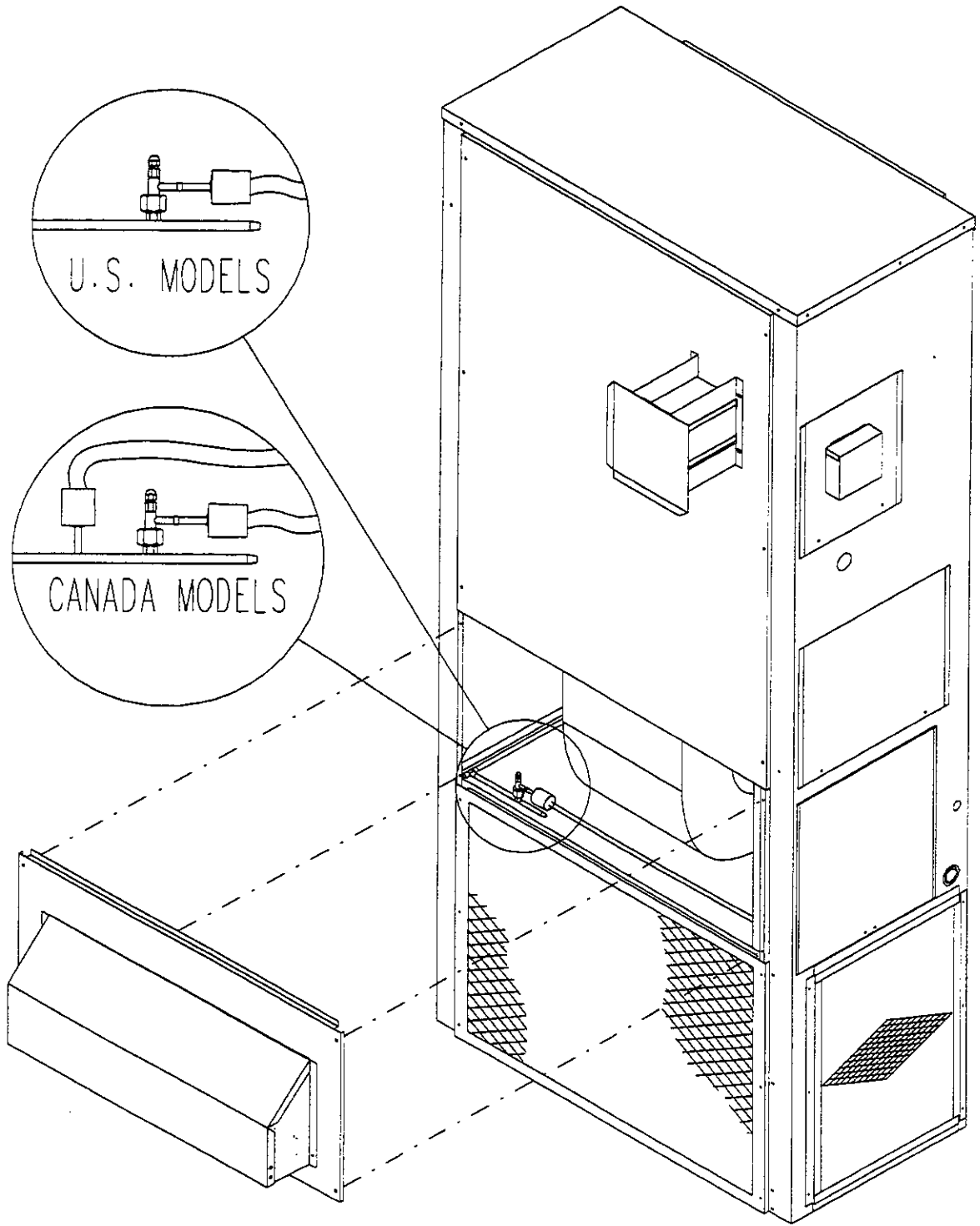

MIS-1072



Bard Manufacturing Company
Bryan, Ohio 43506

INSTALLATION INSTRUCTIONS CMH-7 LOW AMBIENT CONTROL

DESCRIPTION

The CMH-7 is a field installable low ambient fan cycling control kit. The CMH-7 consists of:

1. Installation Instruction 7960-237A
2. Low Ambient Fan Cycling Control 1804-0108
3. Control Assembly 910-1096
4. CMH-7 Unit Label 7961-312-0004

For use with all WH181 – WH602 Hi-Boy Wall Mount Heat Pumps (A & B Electrical Versions).

INSTALLATION INSTRUCTIONS

Disconnect all power to unit. Remove control panel inner and outer covers, and right side condenser inlet grille. Circled numbers on Figure 2 correspond to installation instruction steps. Dashed lines indicate that a wire has been disconnected from this terminal and reconnected to another terminal.

- Step 1. Mount control assembly 910-1096 into control panel as shown with screws provided. Figure 2 or 3, Step 1.
- Step 2. Disconnect black high voltage outdoor motor lead from heat pump control and reconnect to terminal #2 of control assembly 910-1096. Route wires through wire holder as shown in Figure 2 or 3, Step 2.
- Step 3. Connect black wire from terminal #4 of the control assembly 910-1096 to the Com. terminal on the heat pump control board. This is the terminal that the wire was removed from in Step 2. Route wires through wire holder as shown in Figure 2 or 3, Step 3.
- Step 4. Remove the blue wire from terminal B of the heat pump control and reconnect to the #1 terminal of control assembly 910-1096. See Figure 2 or 3, Step 4.
- Step 5. Connect the blue wire from control assembly 910-1096 to B terminal of the heat pump control. See Figure 2 or 3, Step 5.
- Step 6. Connect the brown wire from control assembly 910-1096 to C terminal of the compressor contactor coil. This is the side of the contactor coil that the black wire is attached to. See Figure 2 or 3, Step 6.
- Step 7. Route low ambient control wires up through the bushing in the bottom of the control panel. Replace sealing compound after routing wires through the bushing. Route the wires through the wire holders in the control panel as shown in Figure 2. Connect the low ambient control wires between the terminal #2 and #4 of the control assembly 910-1096. See Figure 2 or 3, Step 7.
- Step 8. Remove service port cap on discharge line. Install the low ambient control on the discharge line with the flare tee adapter that is brazed to the low ambient control. Check for pressure at the flare tee dill valve after installation to insure that the dill valve in the unit service port was depressed by the flare tee connector. Check for leaks at the flare tee connectors. Replace service port cap on the flare tee service port and tighten. See Figure 4.

Step 9. Recheck all wiring. See Figure 1. Check for proper operation of the unit by energizing in cooling mode. The condenser fan motor should not run until the discharge pressure has exceeded 280 PSI. Should the liquid pressure fall below 180 PSI while running, the condenser fan motor will de-energize until the head pressure builds to 280 PSI. Switch to heating mode. The condenser fan motor should run any time the compressor is running regardless of discharge pressure. Run unit through a defrost cycle. The condenser fan should de-energize during the defrost cycle.

Step 10. Apply "This unit equipped with CMH-7 control module" label to the inside of the inner control panel cover above the wiring diagram.

Step 11. Replace all panels and covers. This completes installation.

FIGURE 1

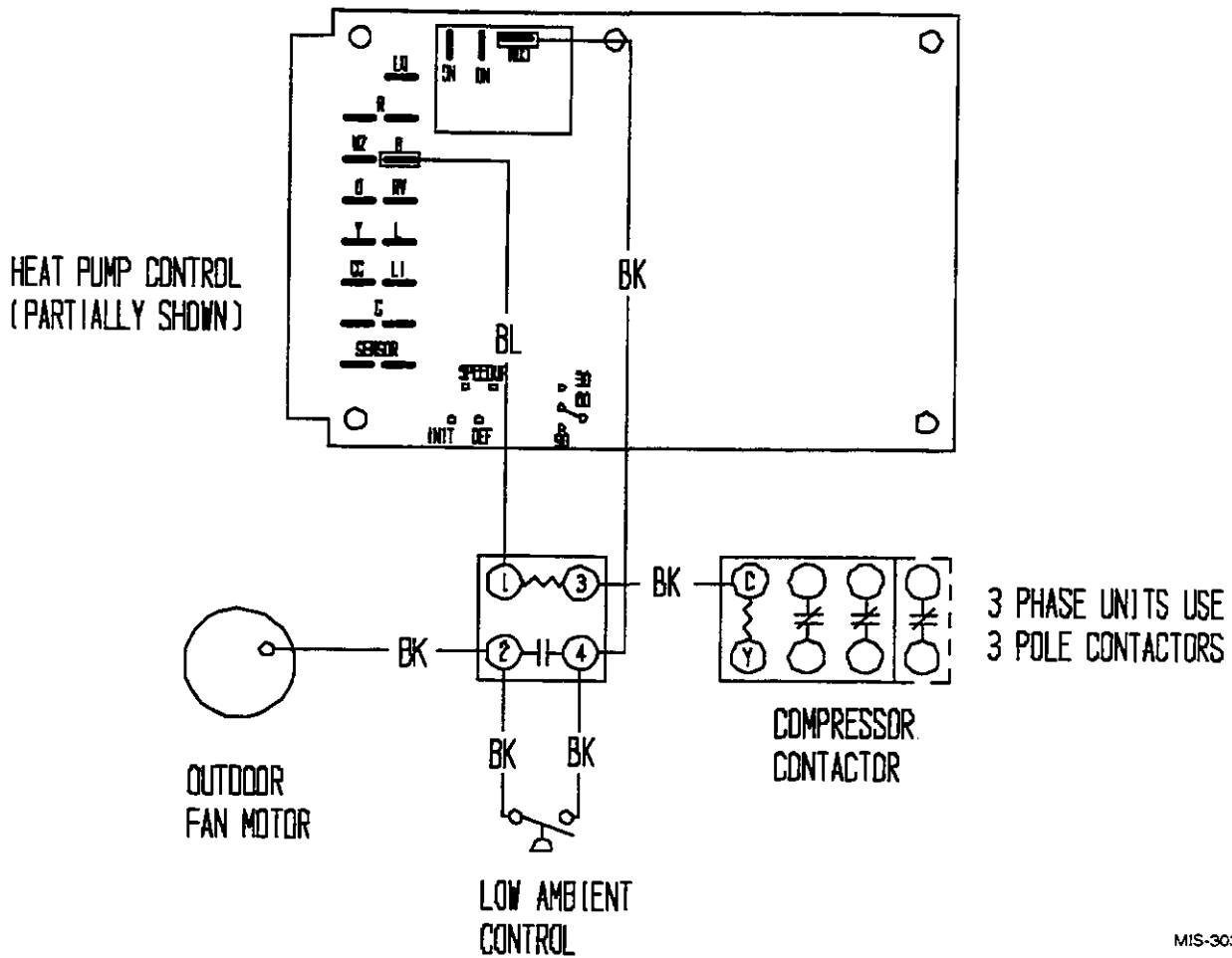

MIS-303

FIGURE 2

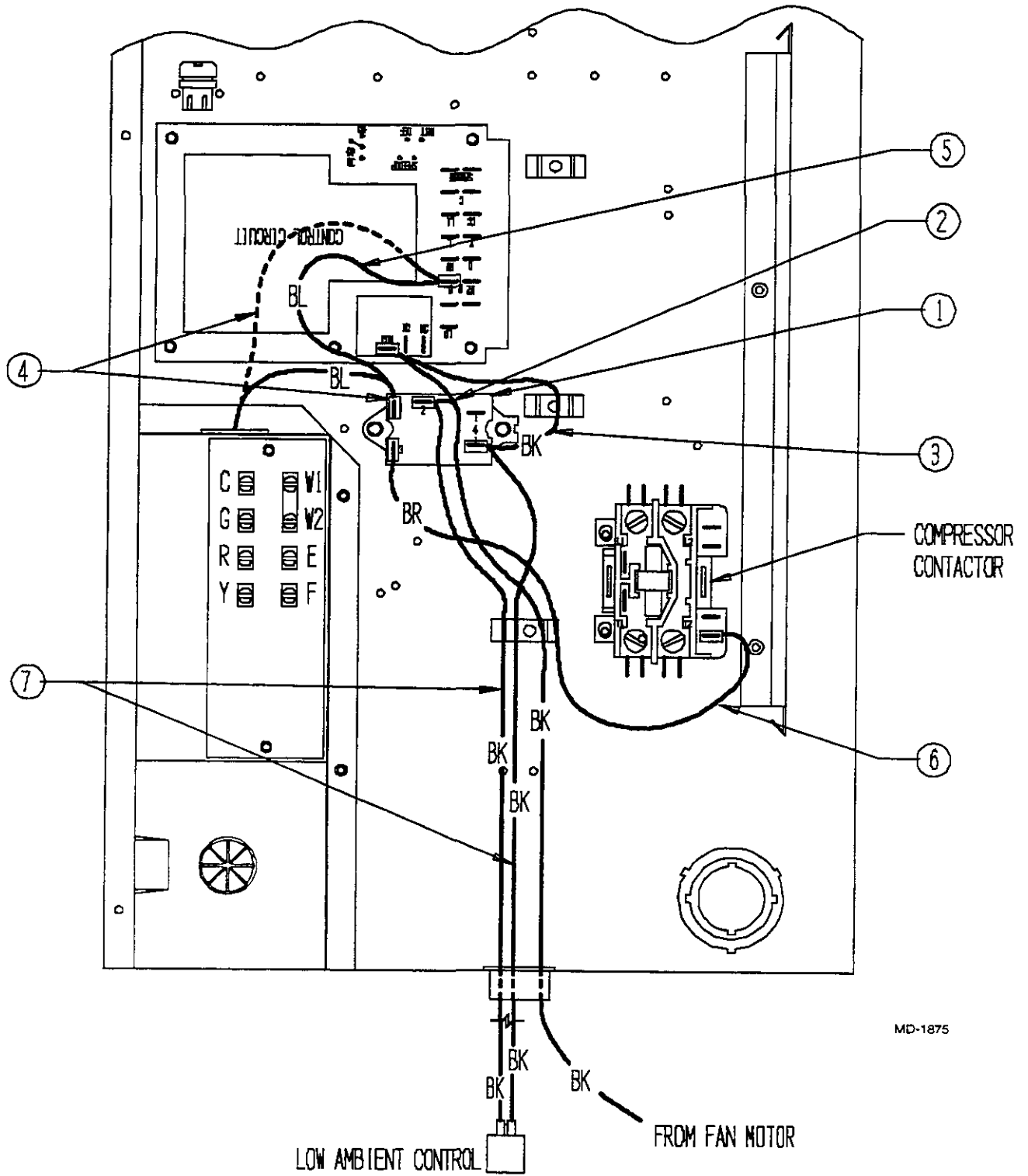

MD-1875

FIGURE 3

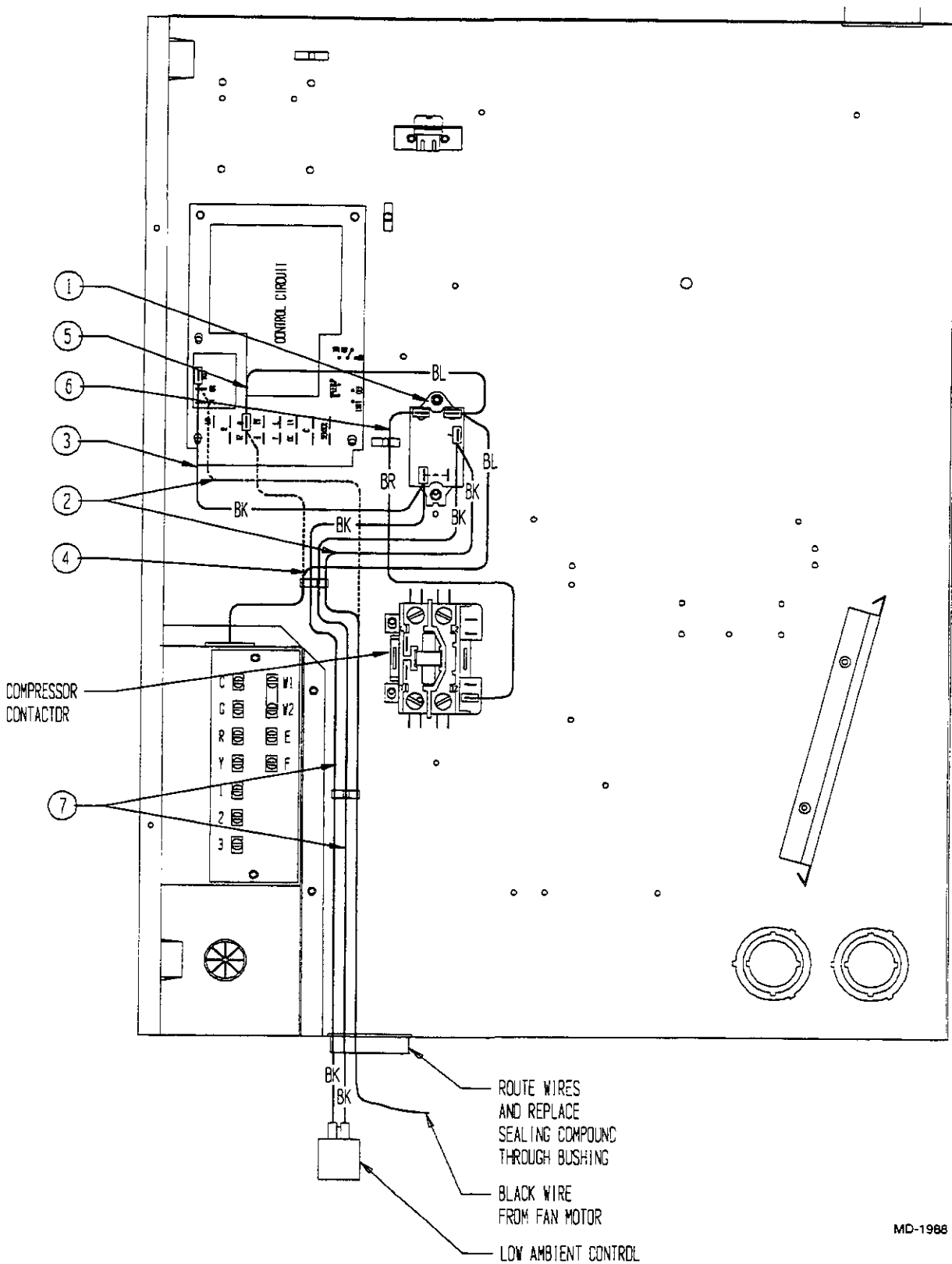

MD-1988

FIGURE 4

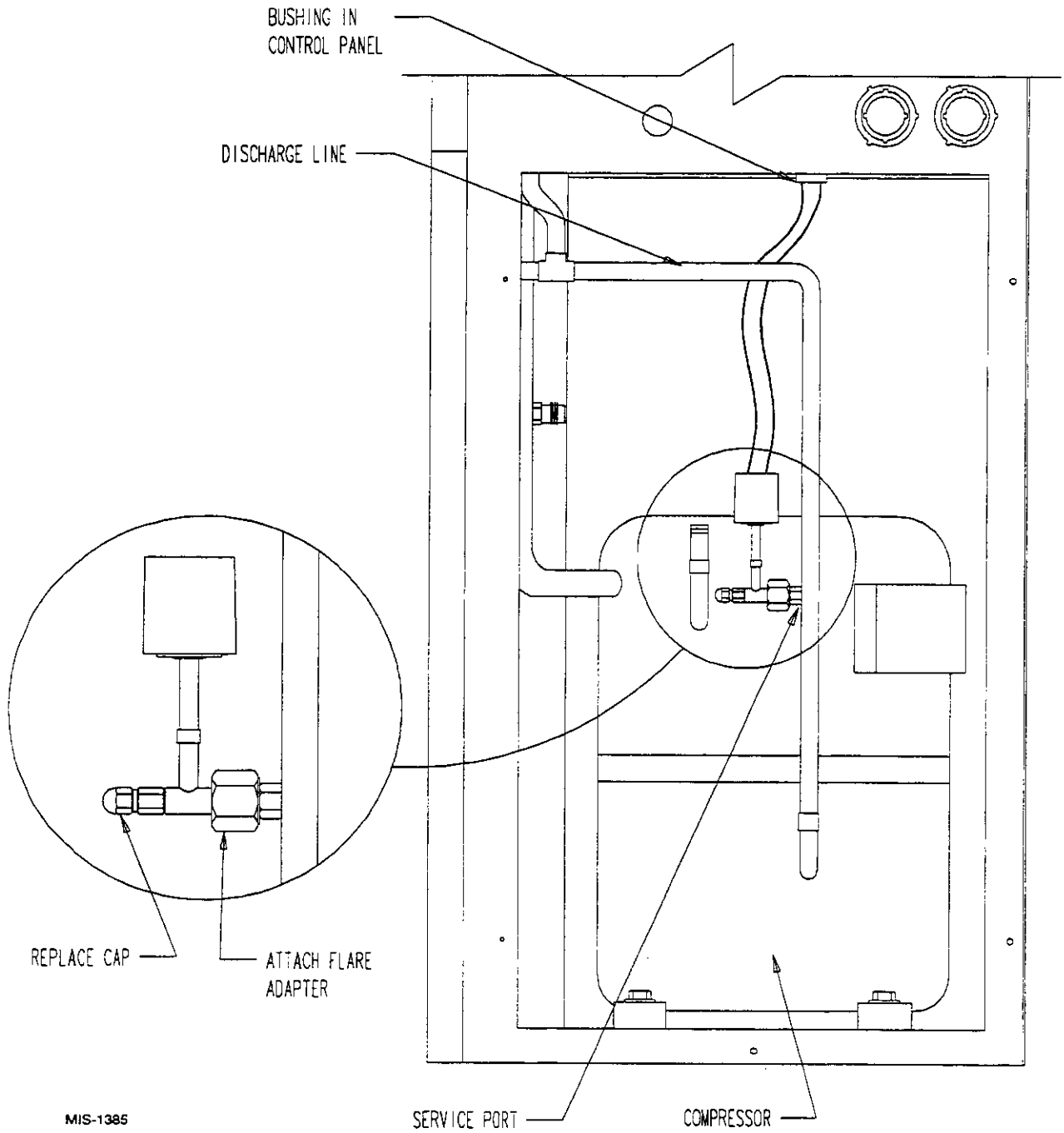

MIS-1385



Bard Manufacturing Company
Bryan, Ohio 43506

INSTALLATION INSTRUCTIONS

CMH-9

LOW PRESSURE AND LOW AMBIENT CONTROL

DESCRIPTION

The CMH-9 is a field installable low pressure control and low ambient fan cycling control kit. The CMH-9 consists of:

1. Installation Instructions 7960-239
2. Low Ambient Fan Cycling Control 1804-0108
3. Control Assembly 910-1096
4. Low Pressure Control 1804-0107
5. Unit Label 7961-312-0004

For use with all WH181 – WH601 Hi-Boy Wall Mount Heat Pump (A & B Electrical Versions)

INSTALLATION INSTRUCTIONS

Disconnect all power to unit. Remove control panel inner and outer covers, and right side condenser inlet grille. Circled numbers on Figure 2 correspond to installation instruction steps. Dashed lines indicate that a wire has been disconnected from this terminal and reconnected to another terminal.

- Step 1. Mount control assembly 910-1096 into control panel as shown with screws provided. Figure 2, Step 1.
- Step 2. Disconnect Black high voltage outdoor motor lead from heat pump control and reconnect to terminal #2 of control assembly 910-1096. Route wires through wire holder as shown in Figure 2, Step 2.
- Step 3. Connect black wire from terminal #4 of the control assembly 910-1096 to the Com. terminal on the heat pump control board. This is the terminal that the wire was removed from in Step 2. Route wires through wire holder as shown in Figure 2, Step 3.
- Step 4. Remove the blue wire from terminal B of of the heat pump control and reconnect to the #1 terminal of control assembly 910-096. See Figure 2, Step 4.
- Step 5. Connect the blue wire from control assembly 910-1096 to B terminal of the heat pump control. This is the side of the contactor coil that the black wire is attached to. See Figure 2, Step 5.
- Step 6. Connect the brown wire from control assembly 910-1096 to C terminal of the compressor contactor coil. This is the side of the contractor coil that the black wire is attached to. See Figure 2, Step 6.
- Step 7. Route low ambient control wires up through the bushing in the bottom of the control panel. Replace sealing compound after routing wires through the bushing. Route the wires through the wire holders in the control panel as shown in Figure 2. Connect the low ambient control wires between the terminals #2 and #4 of the control assembly 910-1096. See Figure 2, Step 7.
- Step 8. Mount control assembly 910-1095 into control panel as shown with screws provided. Figure 3, Step 1.
- Step 9. Disconnect red high pressure control wire from heat pump control terminal LO and reconnect to terminal #1 of control assembly 910-1095. Route wires through wire holder as shown in Figure 3, Step 2.
- Step 10. Connect the blue wired from control assembly 910-1095 to LO terminal of the heat pump control. See Figure 3, Step 3.
- Step 11. Route low pressure control wires up through the bushing in the bottom of the control panel. Replace sealing compound after routing wires through the bushing. Route the wires through the wire holders in the control panel as shown in Figure 3. Connect the low pressure control wires between the terminals #1 and #3 of control assembly 910-1095. See Figure 3, Step 4.
- Step 12. Connect the yellow wire from control assembly 910-1095 to Y terminal of the compressor contactor coil. This is the side of the contactor coil that the yellow wire is attached to. See Figure 3, Step 5.
- Step 13. Connect the black wire from control assembly 910-1095 to C terminal of the compressor contactor coil. This is the side of the contactor coil that the black wire is attached to. See Figure 3, Step 6.

Step 14. Remove service port caps on both the suction and discharge lines. Install the low ambient control on the discharge line with the flare tee adapter that is brazed to the controls. Install the low pressure switch on the suction line. Check for pressure at the flare tee dill valves after installation to insure that the dill valve in th unit service port was depressed by the flare tee connector. Check for leaks at the flare tee connectors. Replace service port caps on the flare tee service ports and tighten. See Figure 4.

Step 15. Recheck all wiring. See Figure 1. Check for poper operation of the unit by energizing in cooling mode. The condenser fan motor

should not run until the discharge pressure has exceeded 280 PSI. Should the discharge pressure fall below 180 PSI while running, the condenser fan motor will de-energize until the head pressure builds to 280 PSI. Switch to heating mode. The condenser fan motor should run any time the compressor is running regardless of discharge pressure. Run unit through a defrost cycle. The condenser fan should de-energize during the defrost cycle.

Step 16. Apply "This unit equipped with CMH-9 control module" label to the inside of the inner control panel cover above the wiring diagram.

Step 17. Replace all panels and covers. This completes installation.

**FIGURE 1
WIRING DIAGRAM**

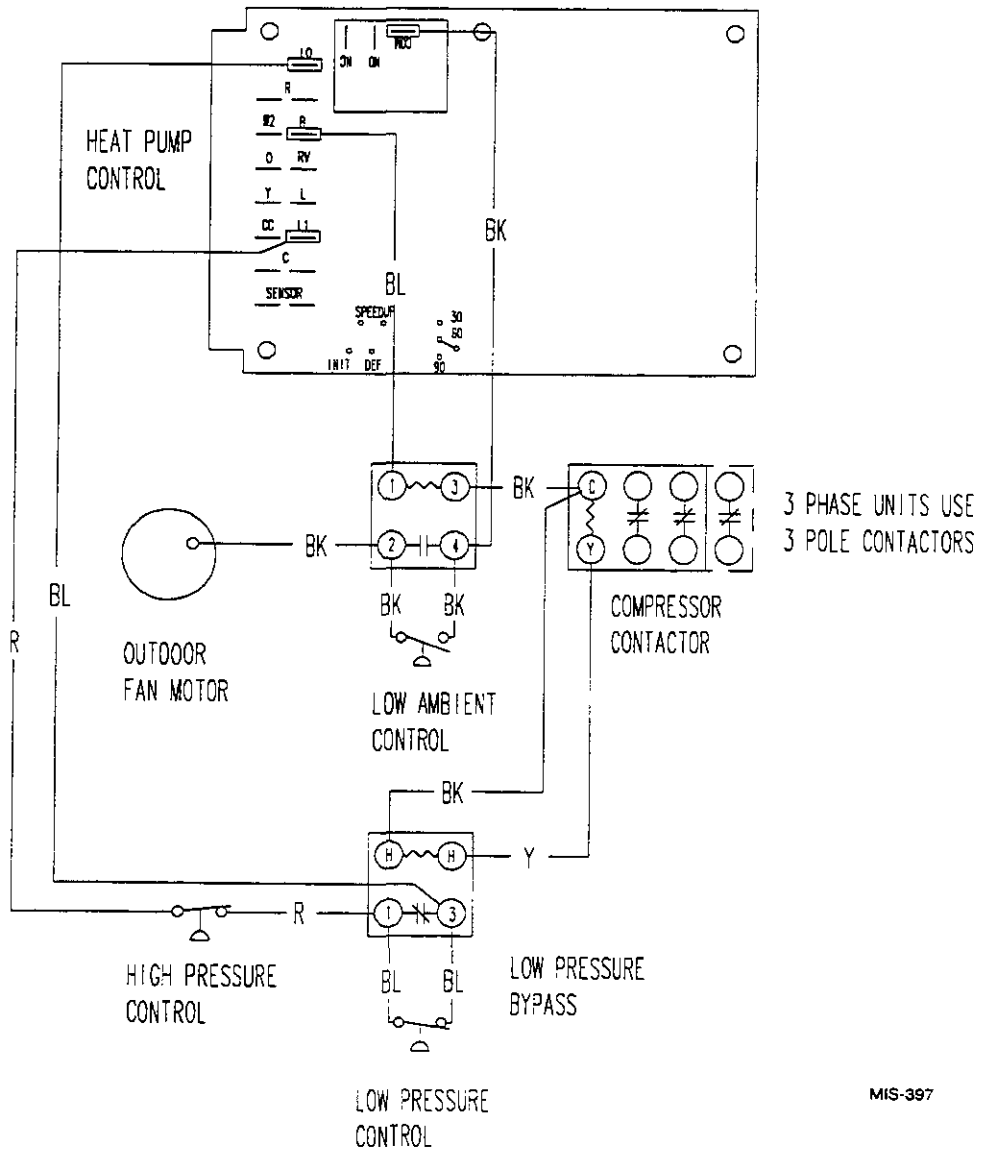

MIS-397

FIGURE 2

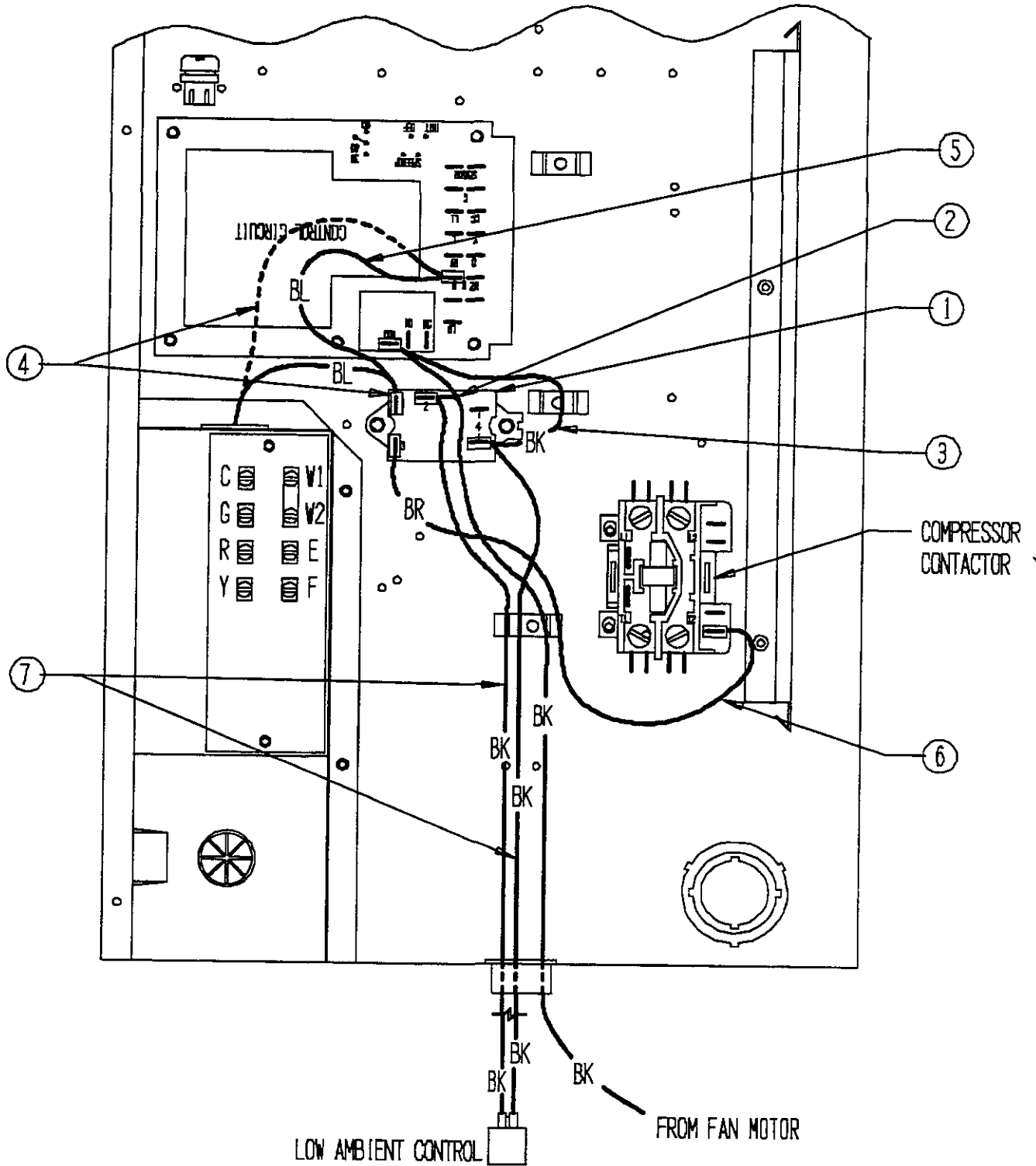

MD-1875

FIGURE 3

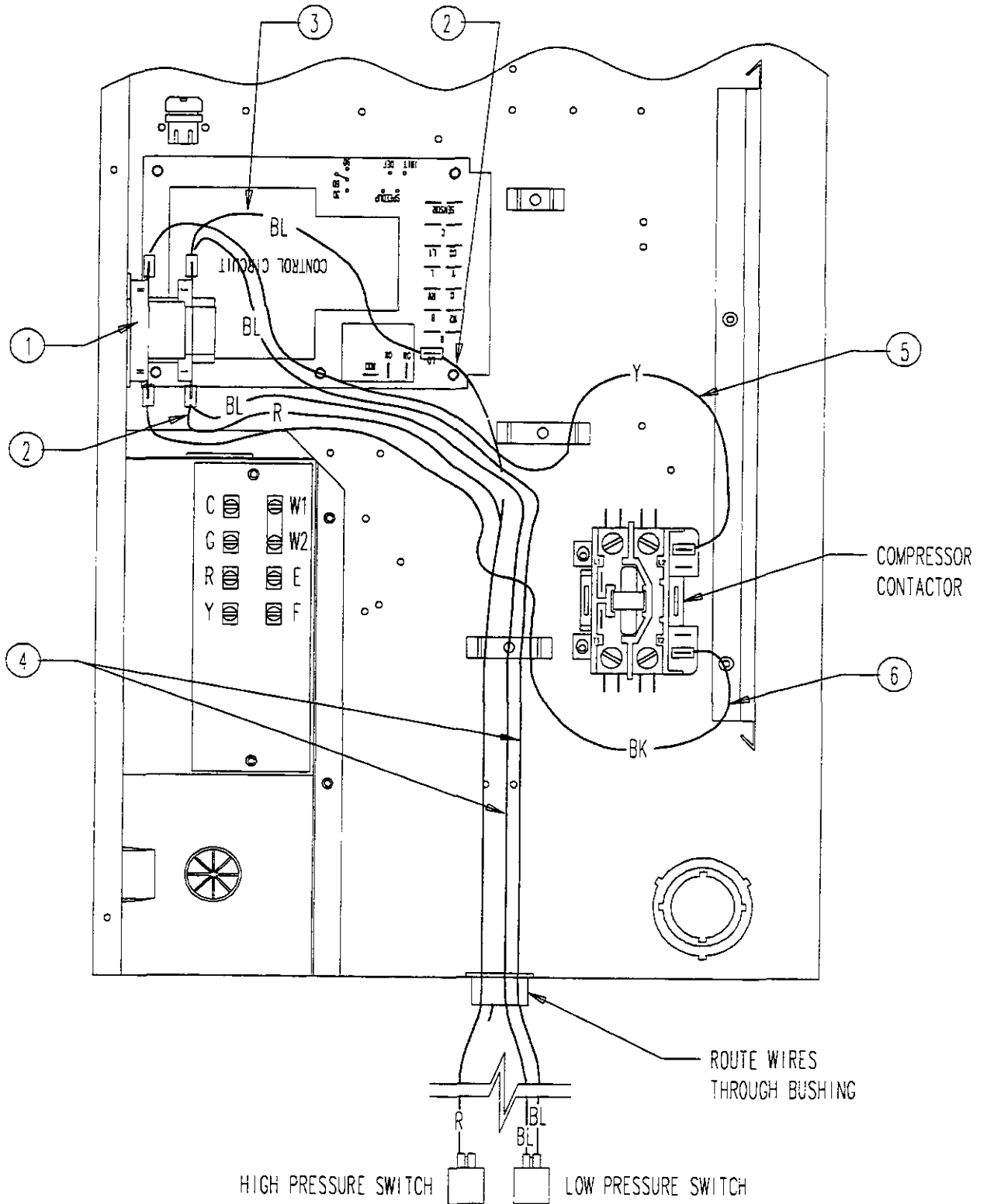
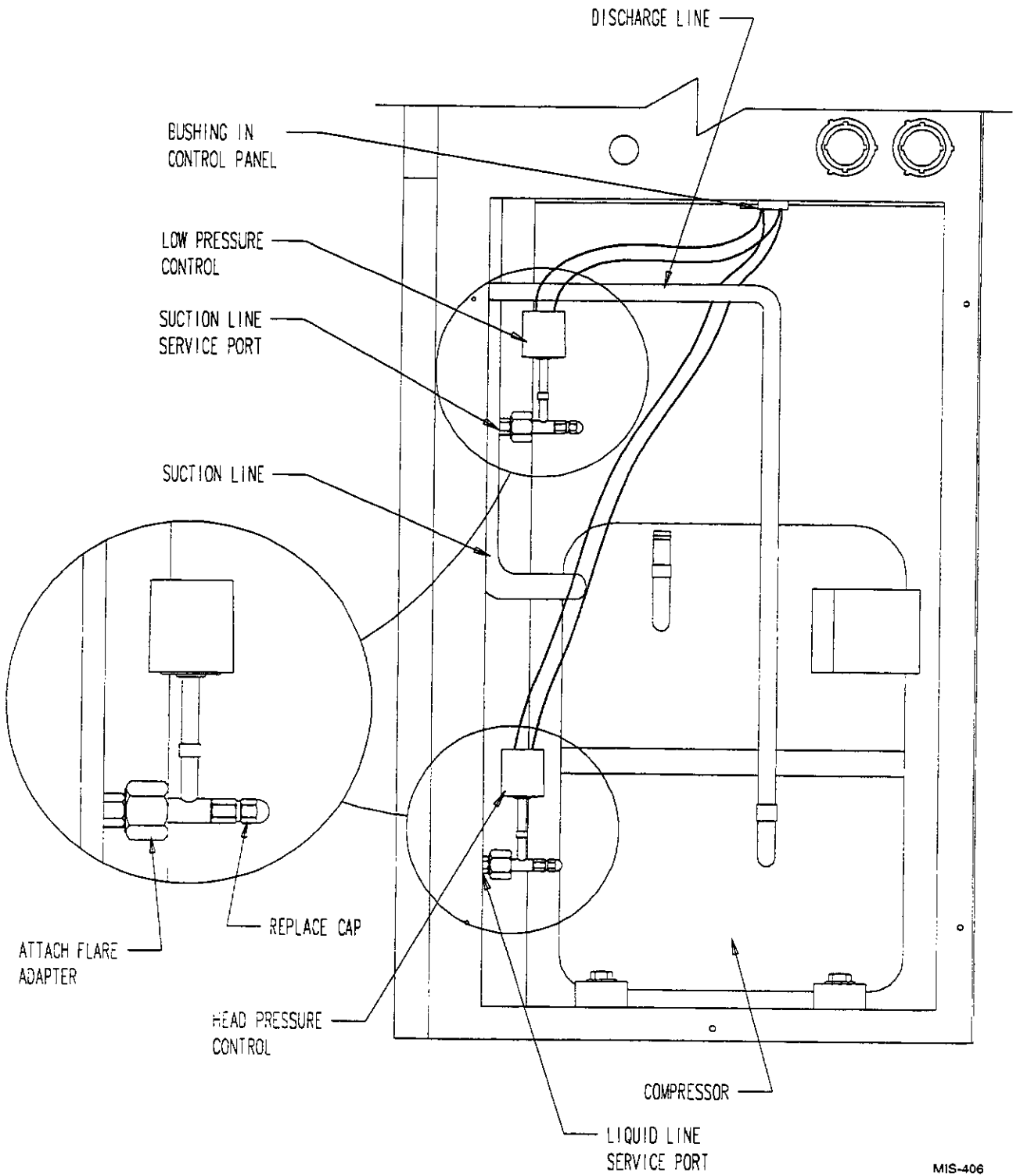

FIGURE 4



MIS-406



Bard Manufacturing Company
Bryan, Ohio 43506

INSTALLATION INSTRUCTIONS

CMA-10A

HIGH and LOW PRESSURE CONTROL and COMPRESSOR CONTROL MODULE WITH TIME DELAY

DESCRIPTION

The CMA-10A is a field installable high and low pressure control and compressor time delay relay control kit. The CMA-10A consists of:

1. Installation Instructions 7960-433
2. High Pressure Control 1804-0106
3. Low Pressure Control 1804-0107
4. Control Assembly 910-1404
5. Unit Label 7961-312-0114

For use with all WA181 – WA421 Hi-Boy Wall Mount air conditioners and WAG Hi-Boy Wall Mount air conditioners.

INSTALLATION INSTRUCTIONS (WA / WL SERIES ONLY)

Disconnect all power to unit. Remove control panel inner and outer covers and right side condenser inlet grille. Circled numbers on Figure 2 correspond to installation instruction steps.

- Step 1. Screw compressor control module into control panel as shown in Figure 2.
- Step 2. Disconnect yellow low voltage wire from compressor contactor and reconnect to terminal Y of the compressor control module.
- Step 3. Connect the yellow wire from the compressor control module to Y side of the compressor contactor coil. This is the same terminal from which the wire was removed in Step 2.
- Step 4. Connect the black wire from the compressor control module to common "C" side of the compressor contactor coil.
- Step 5. Connect red wire from compressor control module to 24V "R" side of the transformer.
- Step 6. Remove the sealing compound from around the compressor wires in the bottom of the control panel.
- Step 7. Route the high (red) and low (blue) pressure switch wires through the bushing in the bottom of the control panel.

Connect the low pressure switch wire to terminals LPC of the compressor control module. Connect the high pressure switch wires to terminals HPC of the compressor control module.

- Step 8. Replace sealing compound after routing the wires through the bushing.
- Step 9. Remove service port caps on both the suction and discharge lines. Install the high pressure switch on the discharge line with the flare tee adapter that is brazed to the controls. Install the low pressure switch on the suction line. Check for pressure at the flare tee dill valves after installation to insure that the dill valve in the unit service port was depressed by the flare tee connector. Check for leaks at the flare tee connectors. Replace service port caps on the flare tee service ports and tighten. See Figure 3.
- Step 10. Adjust the compressor time delay relay to the desired delay on break. Two minutes are recommended. This TDR is variable from 30 seconds to 5 minutes.
- Step 11. Recheck wiring. Refer to Figure 1. Reapply power to the unit. The delay on power up begins timing when low voltage power is supplied to the compressor control module through "C" and "R" terminals. The delay on power up time is 2 minutes plus 10% of the delay on break period. Energize 1st and 2nd stage cooling. Compressor should not start until the delay on power up has expired. The delay on break period begins whenever Y is de-energized. The time period for the delay on break period is set by the red knob. Run the unit for at least 5 minutes. The unit should not go into lockout.

During routine operation of the unit with no power interruptions the compressor will operate on demand with no delay
- Step 12. Apply "This unit equipped with CMA-10A control module." label to the inside of the inner control panel cover above the wiring diagram.
- Step 13. Replace all panels and covers. This completes installation.

**FIGURE 1
WIRING DIAGRAM**

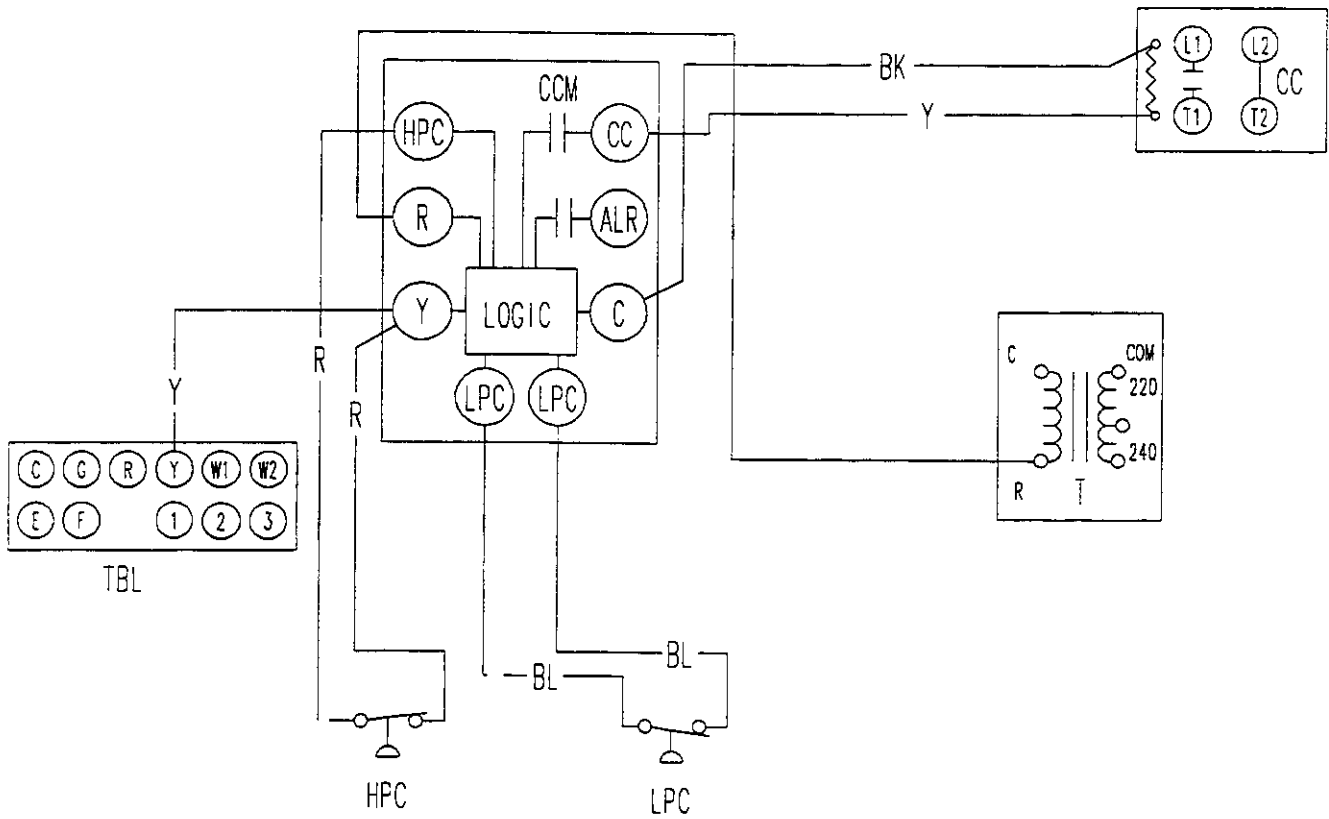

MIS-1280

FIGURE 2

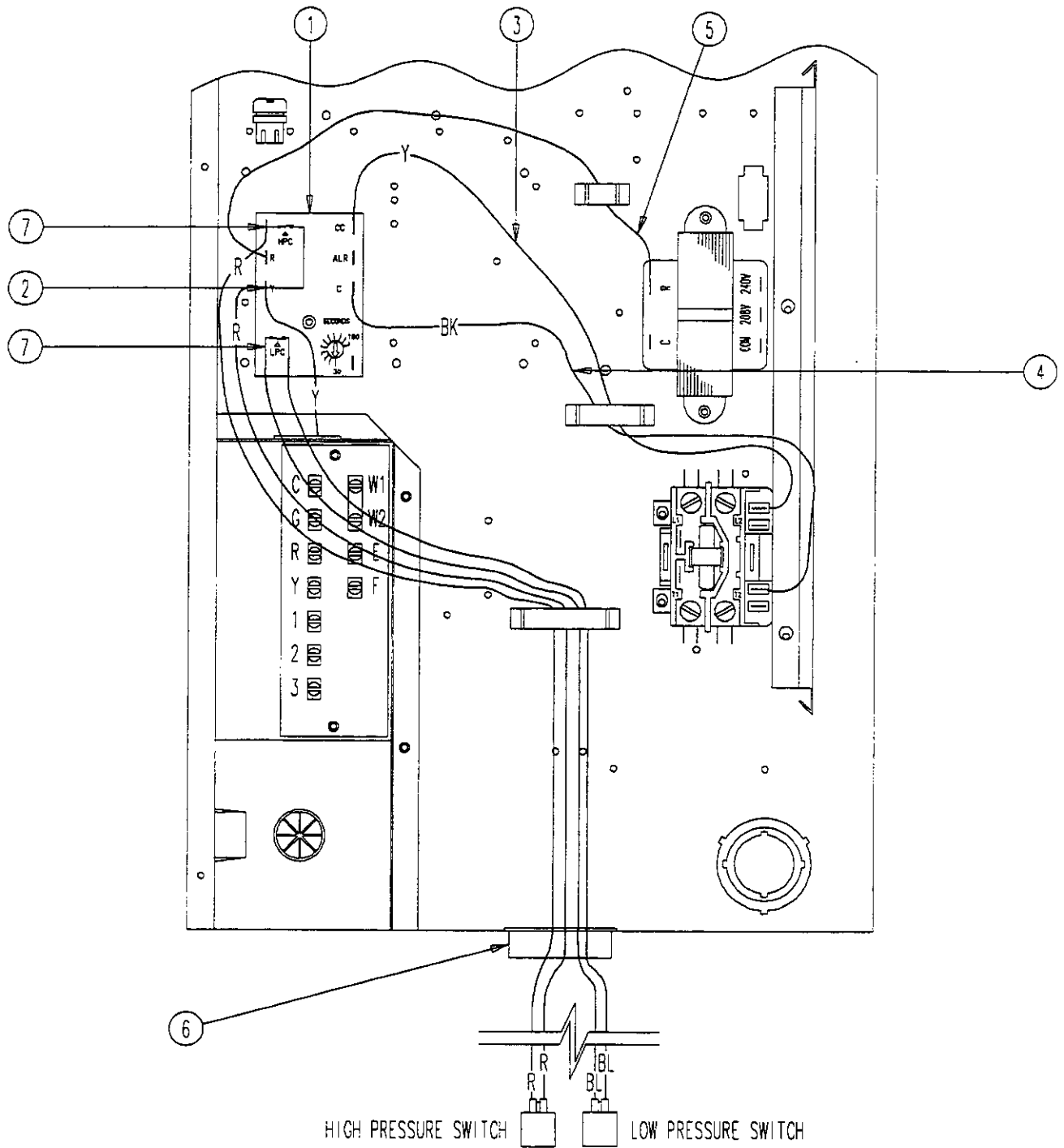

MIS-1281

FIGURE 3

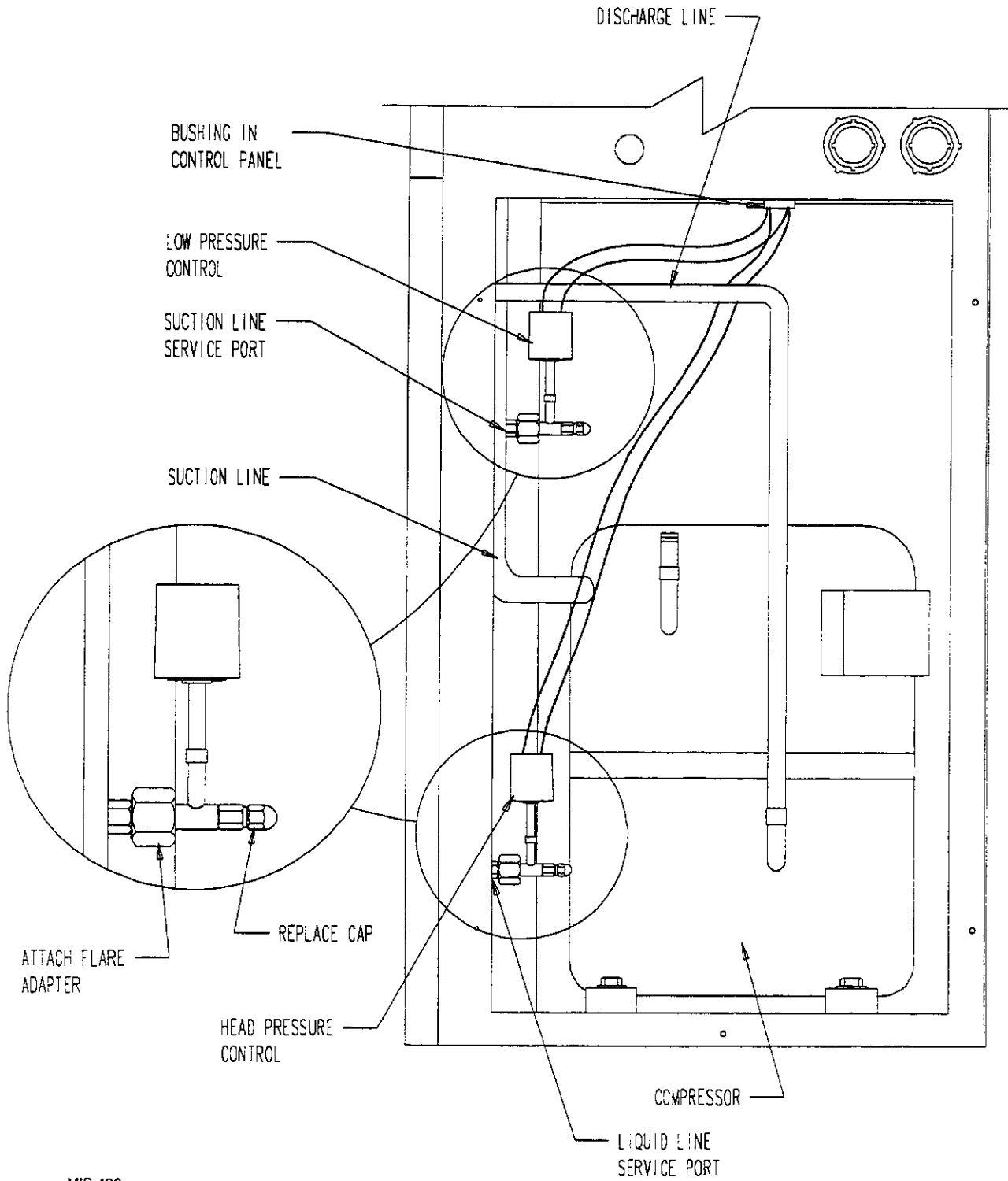

MIS-406

INSTALLATION INSTRUCTIONS (WAG GAS-ELECTRIC SERIES ONLY)

Disconnect all power to unit. Remove control panel inner and outer covers and right side condenser outlet grille. Circled numbers on Figure 4 correspond to installation instruction steps. Dashed wires indicate that a wire has been disconnected from this terminal.

- Step 1. Screw compressor control module into control panel as shown in Figure 4.
- Step 2. Disconnect yellow low voltage (Y) wire from the compressor contactor coil and reconnect to terminal "Y" on the compressor control module.
- Step 3. Connect yellow wire from terminal "CC" of the compressor control module to the (Y) terminal of the compressor contactor.
- Step 4. Connect the black wire from terminal "C" of the compressor control module to the common side of the compressor contactor.
- Step 5. Remove hole plug in the control panel. Route the low (blue) pressure switch wires up through the bushing in the compressor partition. Route high (red) and low (blue) pressure switch wires through the back of the control panel.
- Step 6. Connect the high pressure switch wires to the HPC terminals of the compressor control module.
- Step 7. Connect the low pressure switch wires to the LPC terminals of the compressor control module.
- Step 8. Remove the service port caps on the suction and liquid lines. Install the high pressure switch on the liquid line with the flare tee adapter that is brazed to the controls. Install the low pressure switch on the suction line. Check for pressure at the flare tee dill valves after installation to insure that the flare tee connector depressed the dill valve in the unit service port. Check for leaks at the flare tee connectors. Replace service port caps on the flare tee service ports and tighten.
- Step 9. Adjust the compressor time delay to the desired delay on start up. This TDR is adjustable from 30 to 180 seconds.
- Step 10. Recheck wiring. Refer to Figure 1. Energize the unit in first stage cooling. The compressor should not start until the time delay has expired. Run the unit for at least five minutes. The unit should not go into lockout.
- Step 11. Apply "*This unit equipped with CMA-10A control module.*" label to the inside of the inner control panel cover above the wiring diagram.
- Step 12. Replace all panels and covers. This completes the installation.

FIGURE 4

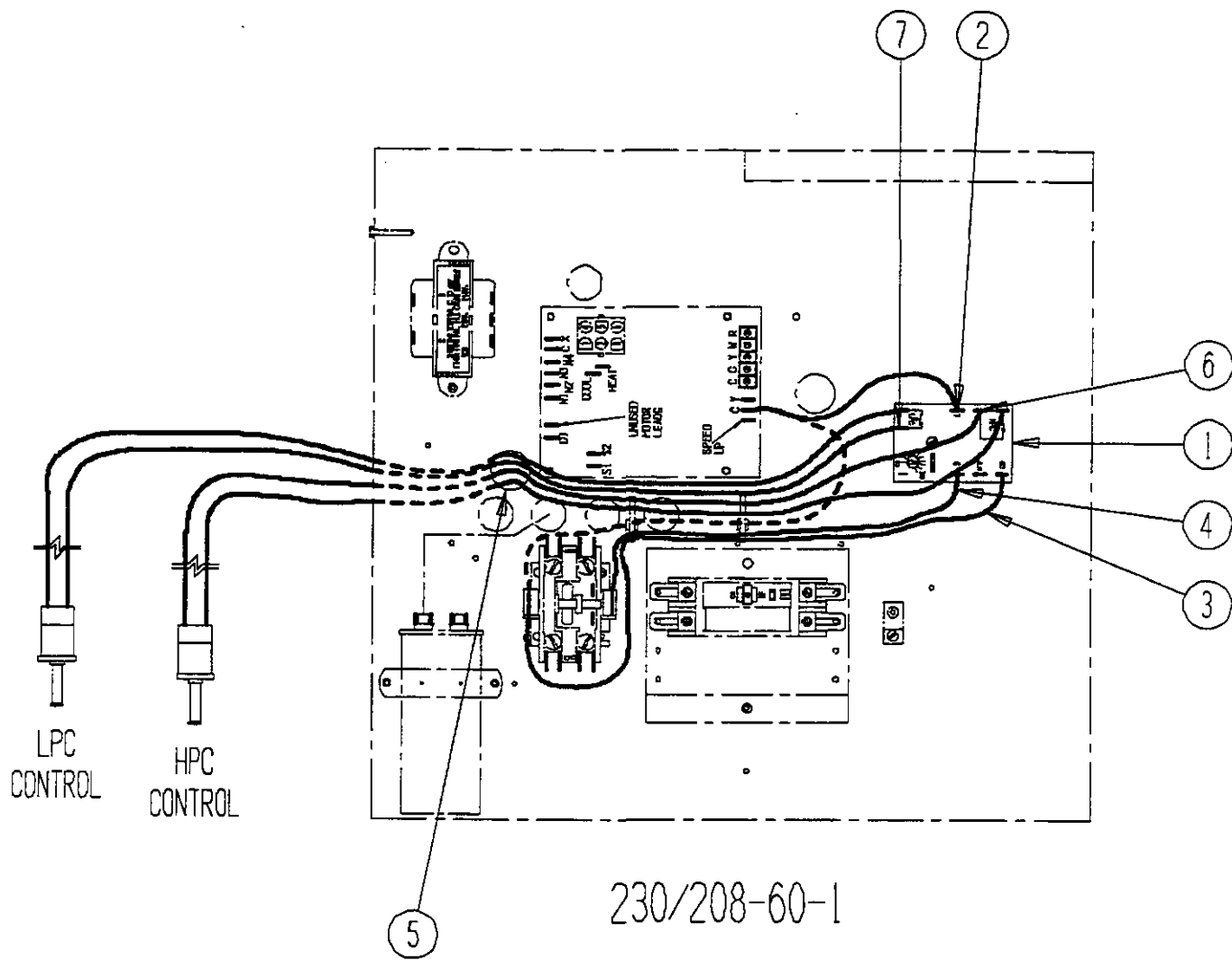

MIS-1273

FIGURE 5

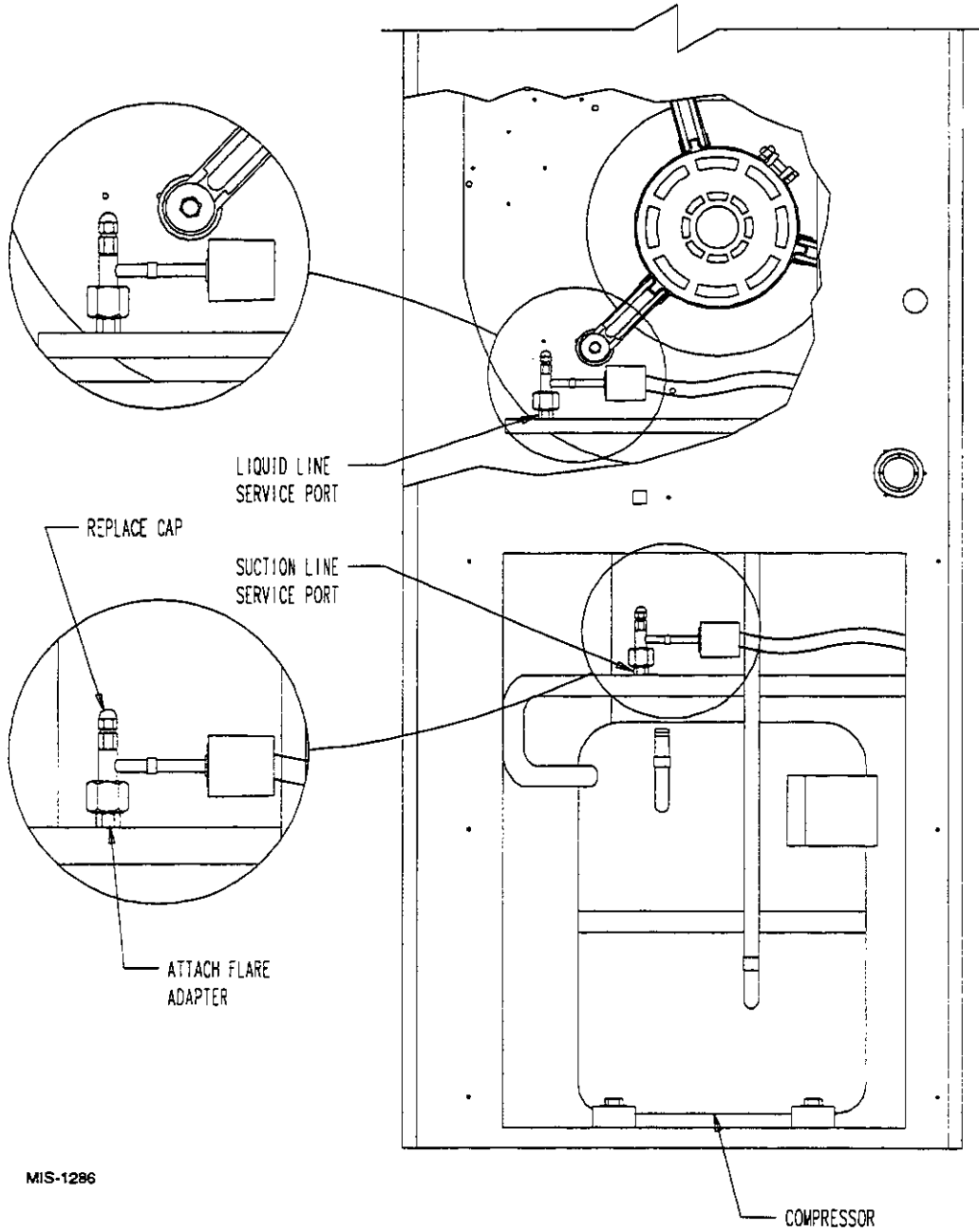

MIS-1286



Bard Manufacturing Company
Bryan, Ohio 43506

INSTALLATION INSTRUCTIONS

CMA-12

LOW AMBIENT CONTROL AND COMPRESSOR TIME DELAY RELAY

DESCRIPTION

The CMA-12 is a field installable compressor time delay relay and low ambient fan cycling control kit. The CMA-12 consists of:

1. Installation Instructions 7960-242
2. Low ambient fan cycling control 1804-0108
3. Control assembly 910-1099
4. Installation Instructions 7960-240
6. Unit Label 7961-312-0004

For use with all WAWL181 – WAWL421 Hi-Boy Wall Mount Air Conditioners (A & B Electrical Versions).

INSTALLATION INSTRUCTIONS

Disconnect all power to unit. Remove control panel inner and outer covers, and right side condenser inlet grille. Circled numbers on Figure 2 correspond to installation instruction steps. Dashed lines indicate that a wire has been disconnected from this terminal.

- Step 1. Snap control assembly into control panel as shown in Figure 2, Step 1.
- Step 2. Disconnect yellow low voltage (Y) wire at compressor contactor coil and reconnect to the Y1 or #3 terminal of the TDR. See Figure 2, Step 2.
- Step 3. Connect yellow wire from terminal (Y) of the TDR to the (Y) terminal of the compressor contactor coil. This is the terminal that the wire was removed from in Step 2. Route wires through wire holder as shown in Figure 2, Step 3.
- Step 4. Disconnect the black high voltage outdoor motor lead from compressor contactor and reconnect to terminal block. Route wires through wire holder as shown in Figure 2, Step 4.
- Step 5. Route low ambient control wires up through the busing in the bottom of the control panel. Replace sealing compound after routing wires through the bushing. Route the wires through the wire holders in the control panel as shown in Figure 2. Connect the low ambient control wires between the terminal block and L2 of the compressor contactor. See Figure 2, Step 5.
- Step 6. Remove service port cap on discharge line. Install the low ambient control on the discharge line with the flare tee adapter that is brazed to the low ambient control. Check for pressure at the flare tee dill valve after installation to insure that the dill valve in the unit service port was depressed by the flare tee connector. Check for leaks at the flare tee connectors. Replace service port cap on the flare tee service port and tighten. See Figure 3.
- Step 7. Recheck wiring. Refer to Figure 1. Check for proper operation of the unit by energizing in cooling mode. The condenser fan motor should not run until the discharge pressure has exceeded 300 PSI. Should the discharge pressure fall below 200 PSI while running, the condenser fan motor will de-energize until the head pressure builds to 300 PSI. Remove power and reapply. Compressor should not start until the 5 minute time delay has expired.
- Step 8. Apply "This unit equipped with CMA-12 control module" label to the inside of the inner control panel cover above the wiring diagram.
- Step 9. Replace all panels and covers. This completes installation.

FIGURE 1

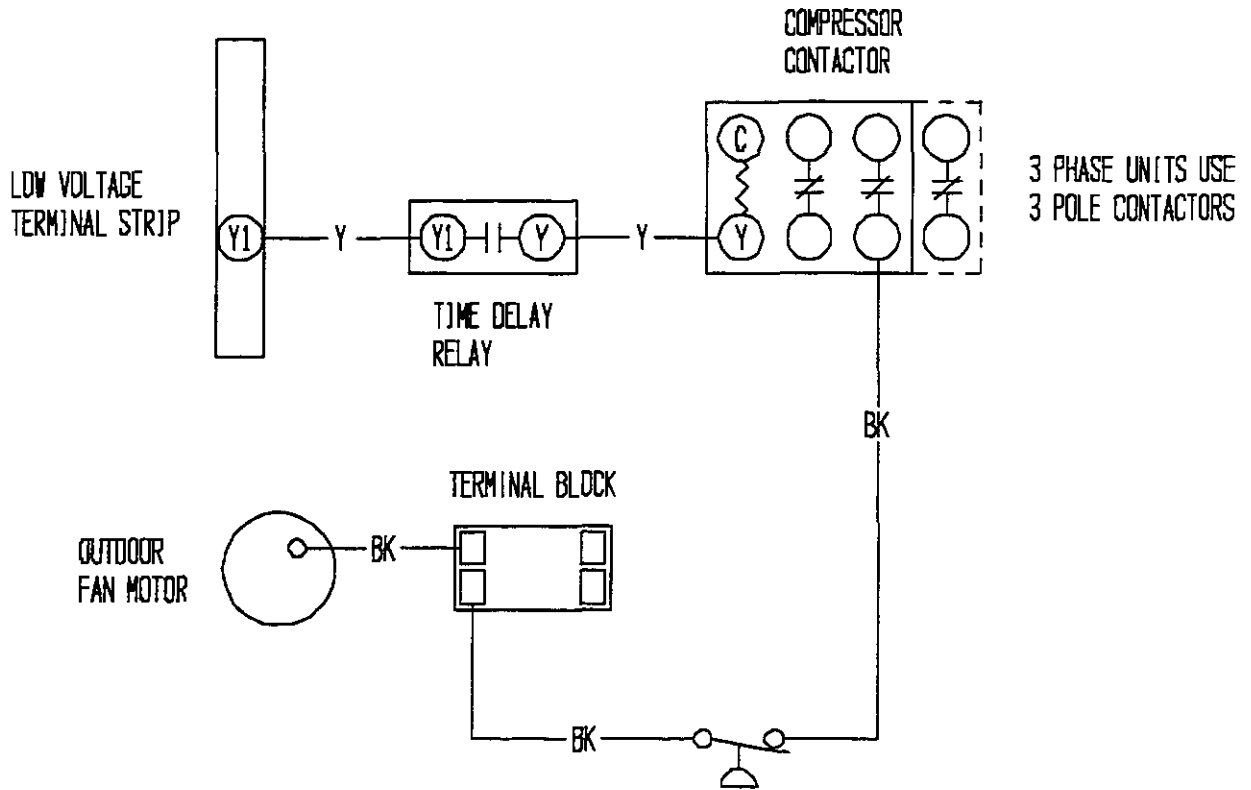

MIS-1379

FIGURE 2

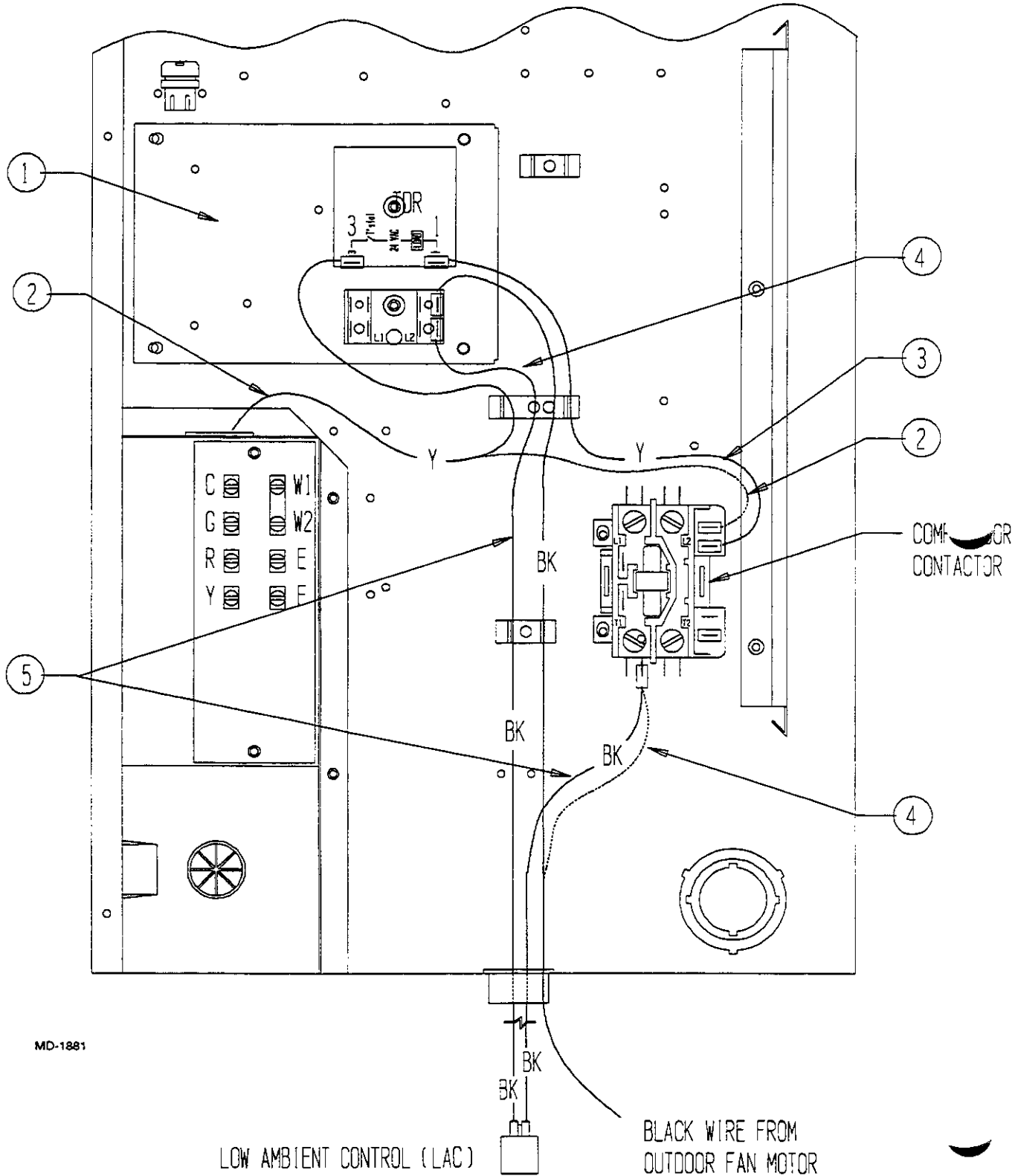

MD-1881

FIGURE 3

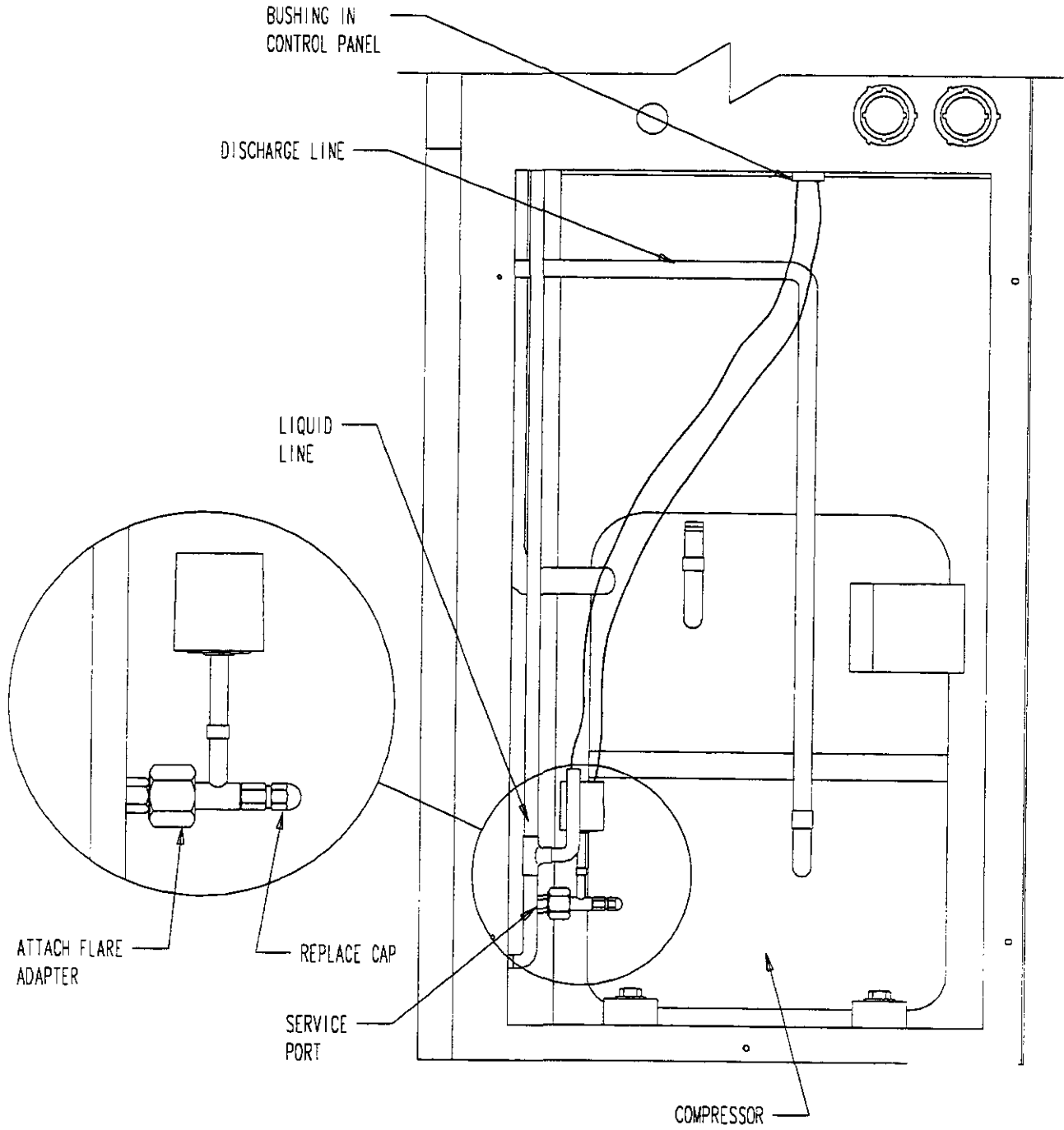

MIS-376



Bard Manufacturing Company
Bryan, Ohio 43506

INSTALLATION INSTRUCTIONS

CMA-13A

LOW AMBIENT FAN CYCLING, HIGH and LOW PRESSURE CONTROL and COMPRESSOR CONTROL MODULE WITH TIME DELAY

DESCRIPTION

The CMA-13A is a field installable high and low pressure control, compressor time delay relay and low ambient fan cycling control kit. The CMA-13A consists of:

1. Installation Instructions 7960-434
2. High Pressure Control 1804-0106
3. Low Pressure Control 1804-0107
4. Low Ambient Fan Cycling Control 1804-0108
5. Control Assembly 910-1404
6. Unit Label 7961-312-0115

For use with all WA181 – WA361 Hi-Boy Wall Mount air conditioners and WAG Hi-Boy Wall Mount air conditioners.

INSTALLATION INSTRUCTIONS (WA181 – WA361 SERIES ONLY)

Disconnect all power to unit. Remove control panel inner and outer covers and right side condenser inlet grille. Circled numbers on Figure 2 correspond to installation instruction steps.

- Step 1. Screw compressor control module and terminal block into control panel as shown in Figure 2.
- Step 2. Disconnect yellow low voltage wire from compressor contactor and reconnect to terminal Y of the compressor control module.
- Step 3. Connect the yellow wire from the compressor control module to Y side of the compressor contactor coil. This is the same terminal from which the wire was removed in Step 2.
- Step 4. Connect the black wire from the compressor control module to common "C" side of the compressor contactor coil.
- Step 5. Connect red wire from compressor control module to 24V "R" side of the transformer.
- Step 6. Remove the sealing compound from around the compressor wires in the bottom of the control panel.
- Step 7. Route the high (red) and low (blue) pressure switch wires through the bushing in the bottom of the control panel. Connect the low pressure switch wire to terminals LPC of the compressor control module. Connect the high pressure switch wires to terminals HPC and "Y" of the compressor control module.
- Step 8. Disconnect the high voltage outdoor motor lead and reconnect to the terminal block installed in Step 1.
- Step 9. Route the LAC (black) wires up through the bushing in the bottom of the control panel. Connect one wire to the terminal block and the other to T2 of the contactor. This will be the same terminal from which the high voltage outdoor motor lead was removed in Step 7. Replace sealing compound after routing the wires through the bushing.
- Step 10. Remove service port caps on both the suction and discharge lines. Install the high pressure switch and low ambient control on the discharge line with the flare tee adapter that is brazed to the controls. Install the low pressure switch on the suction line. Check for pressure at the flare tee dill valves after installation to insure that the dill valve in the unit service port was depressed by the flare tee connector. Check for leaks at the flare tee connectors. Replace service port caps on the flare tee service ports and tighten. See Figure 3.
- Step 11. Adjust the compressor time delay relay to the desired delay on break. Two minutes are recommended. This TDR is variable from 30 seconds to 5 minutes.
- Step 12. Recheck wiring. Refer to Figure 1. Reapply power to the unit. The delay on power-up begins timing when low voltage power is supplied to the compressor control module through "C" and "R" terminals. The delay on power-up time is 2 minutes plus 10% of the delay on break period. Energize 1st and 2nd stage cooling. Compressor should not start until the delay on power-up has expired. The delay on break period begins whenever "Y" is

de-energized. The time period for the delay on break period is set by the red knob. Run the unit for at least 5 minutes. The unit should not go into lockout. During routine operation of the unit with now power interruptions the compressor will operated on demand with no dealy. The condenser fan motor should not run until the discharge pressure has exceeded 280 PSI. Should the discharge pressure fall below 180 PSI while running the condenser fan motor will de-energize until the head pressure builds to 280 PSI.

Step 13. Apply "This unit equipped with CMA-13A control module." label to the inside of the inner control panel cover above the wiring diagram.

Step 14. Replace all panels and covers. This completes installation.

**FIGURE 1
WIRING DIAGRAM**

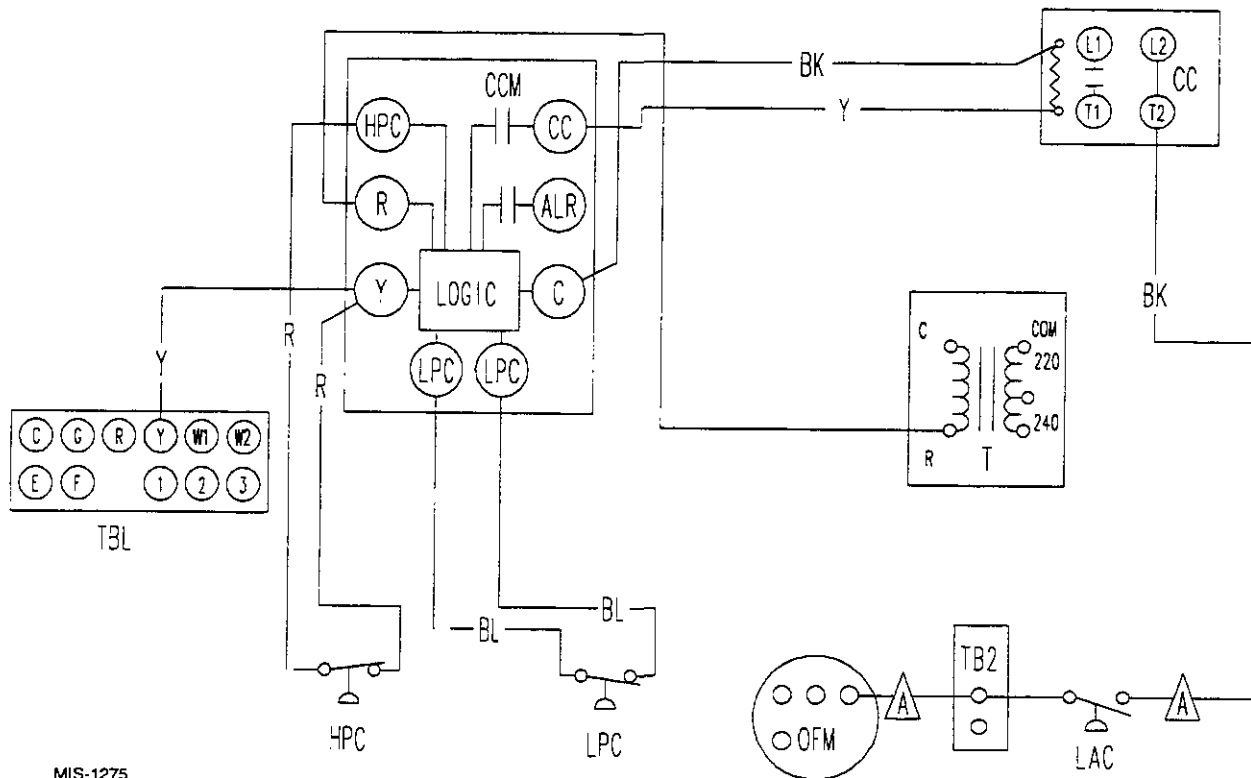

MIS-1275

FIGURE 2

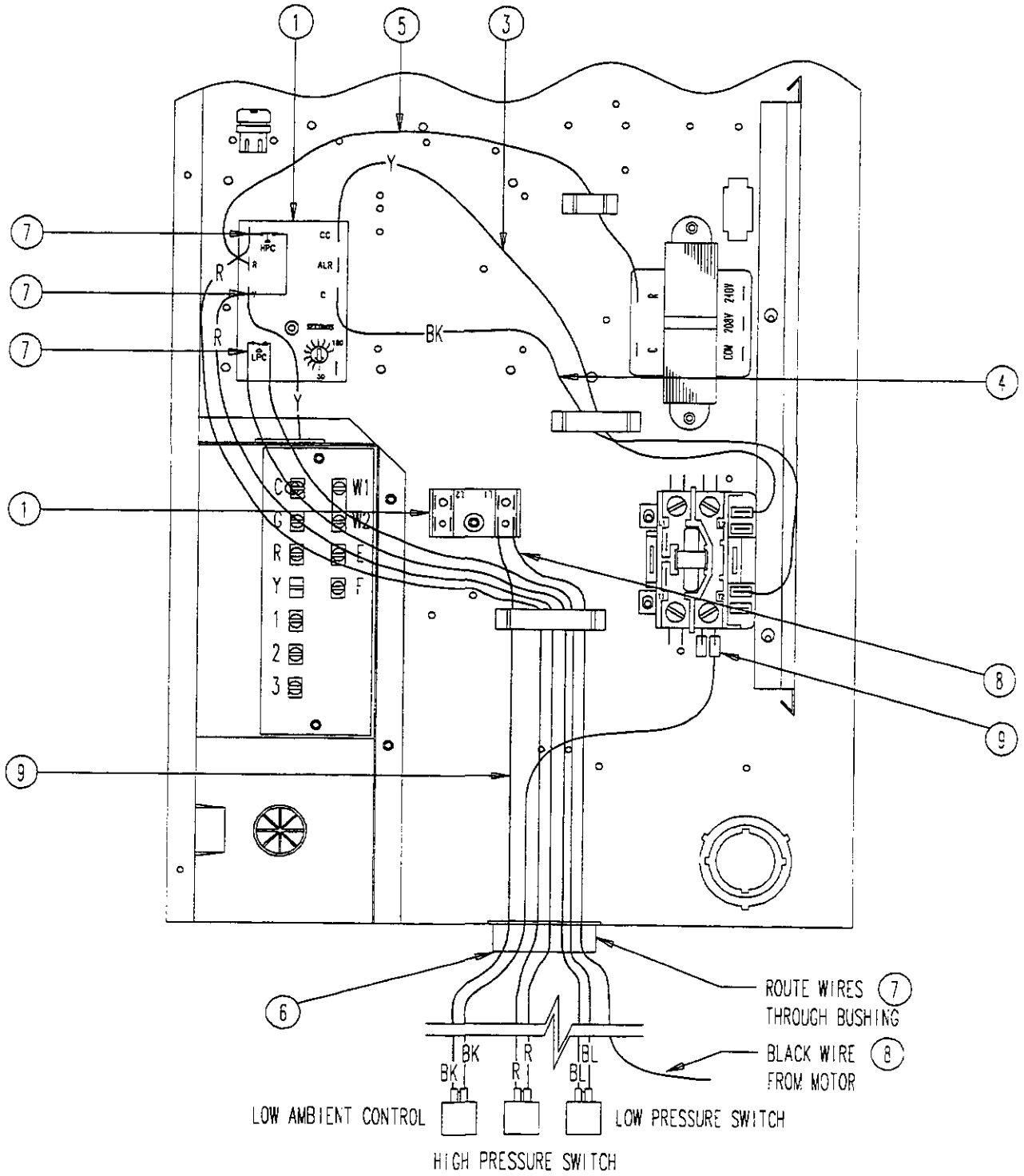

MIS-1274

FIGURE 3

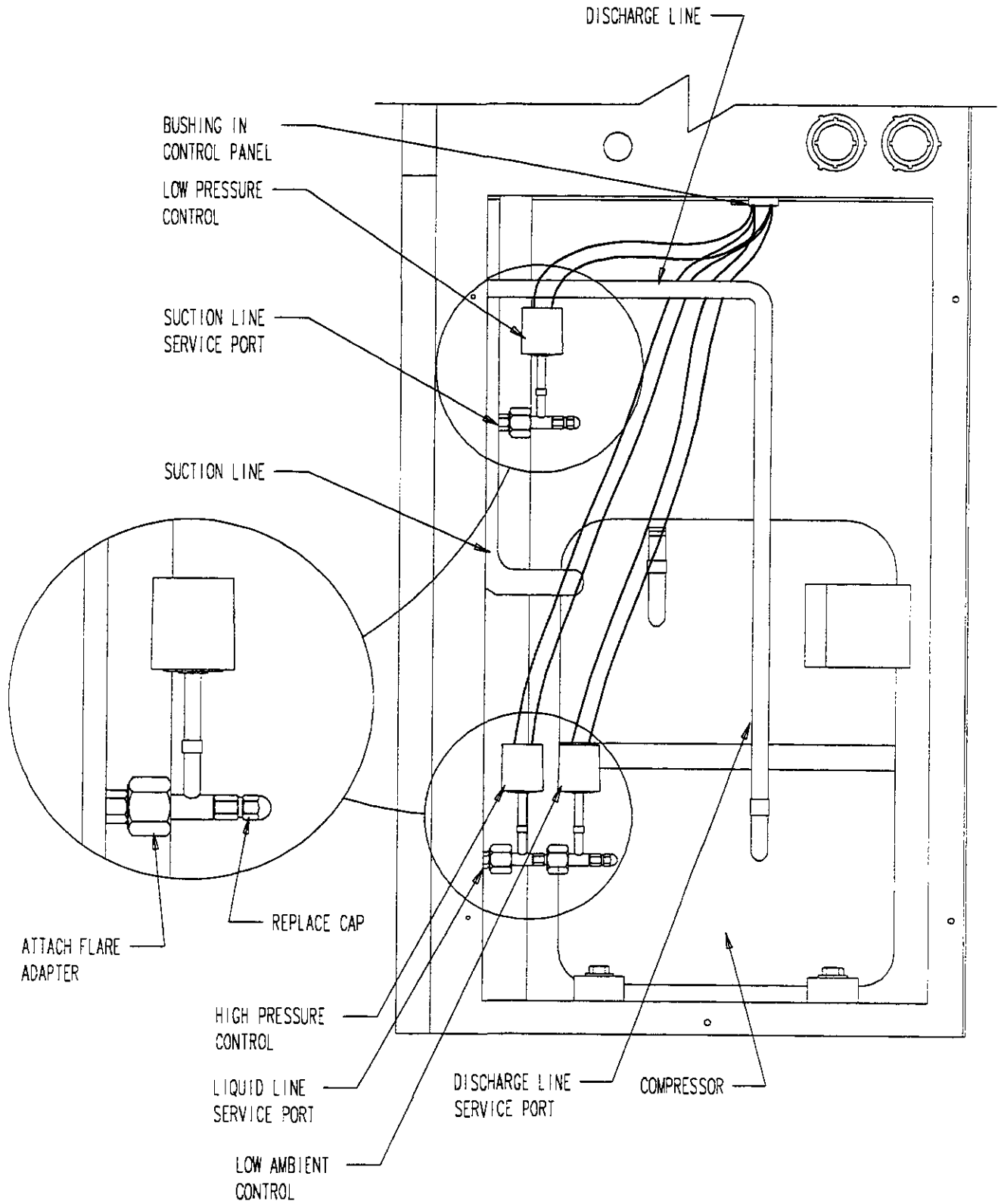

MIS-407

INSTALLATION INSTRUCTIONS (WAG GAS-ELECTRIC SERIES ONLY)

Disconnect all power to unit. Remove control panel inner and outer covers and right side condenser outlet grille. Circled numbers on Figure 4 correspond to installation instruction steps. Dashed wires indicate that a wire has been disconnected from this terminal.

- Step 1. Screw compressor control module and terminal block into control panel as shown in Figure 4.
- Step 2. Disconnect yellow low voltage (Y) wire from the compressor contactor coil and reconnect to terminal "Y" on the compressor control module.
- Step 3. Connect yellow wire from terminal "CC" of the compressor control module to the (Y) terminal of the compressor contactor.
- Step 4. Connect the black wire from terminal "C" of the compressor control module to the common side of the compressor contactor.
- Step 5. Remove hole plug in the control panel. Route the low (blue) pressure switch wires up through the bushing in the compressor partition. Route high (red) and low (blue) pressure switch and the low ambient control (black) wires through the back of the control panel.
- Step 6. Connect the high pressure switch wires to the HPC terminals of the compressor control module.
- Step 7. Connect the low pressure switch wires to the LPC terminals of the compressor control module.
- Step 8. Disconnect black high voltage outdoor motor lead from the compressor contactor and reconnect to terminal block. Connect the low ambient control wires between the terminal block and T2 of the compressor contactor.
- Step 9. Remove the service port caps on the suction and liquid lines. Install the low ambient control and the high pressure switch on the liquid line with the flare tee adapter that is brazed to the controls. Install the low pressure switch on the suction line. Check for pressure at the flare tee dill valves after installation to insure that the flare tee connector depressed the dill valve in the unit service port. Check for leaks at the flare tee connectors. Replace service port caps on the flare tee service ports and tighten.
- Step 10. Adjust the compressor time delay to the desired delay on start up. This TDR is adjustable from 30 to 180 seconds.
- Step 11. Recheck wiring. Refer to Figure 1. Energize the unit in first stage cooling. The compressor should not start until the time delay has expired. Run the unit for at least five minutes. The unit should not go into lockout. The condenser fan should not run until the liquid pressure has exceeded 280 PSI. Should the liquid pressure fall below 180 PSI while running, the condenser fan motor will de-energize until the liquid pressure builds to 280 PSI.
- Step 12. Apply "*This unit equipped with CMA-13A control module.*" label to the inside of the inner control panel cover above the wiring diagram.
- Step 13. Replace all panels and covers. This completes the installation.

FIGURE 4

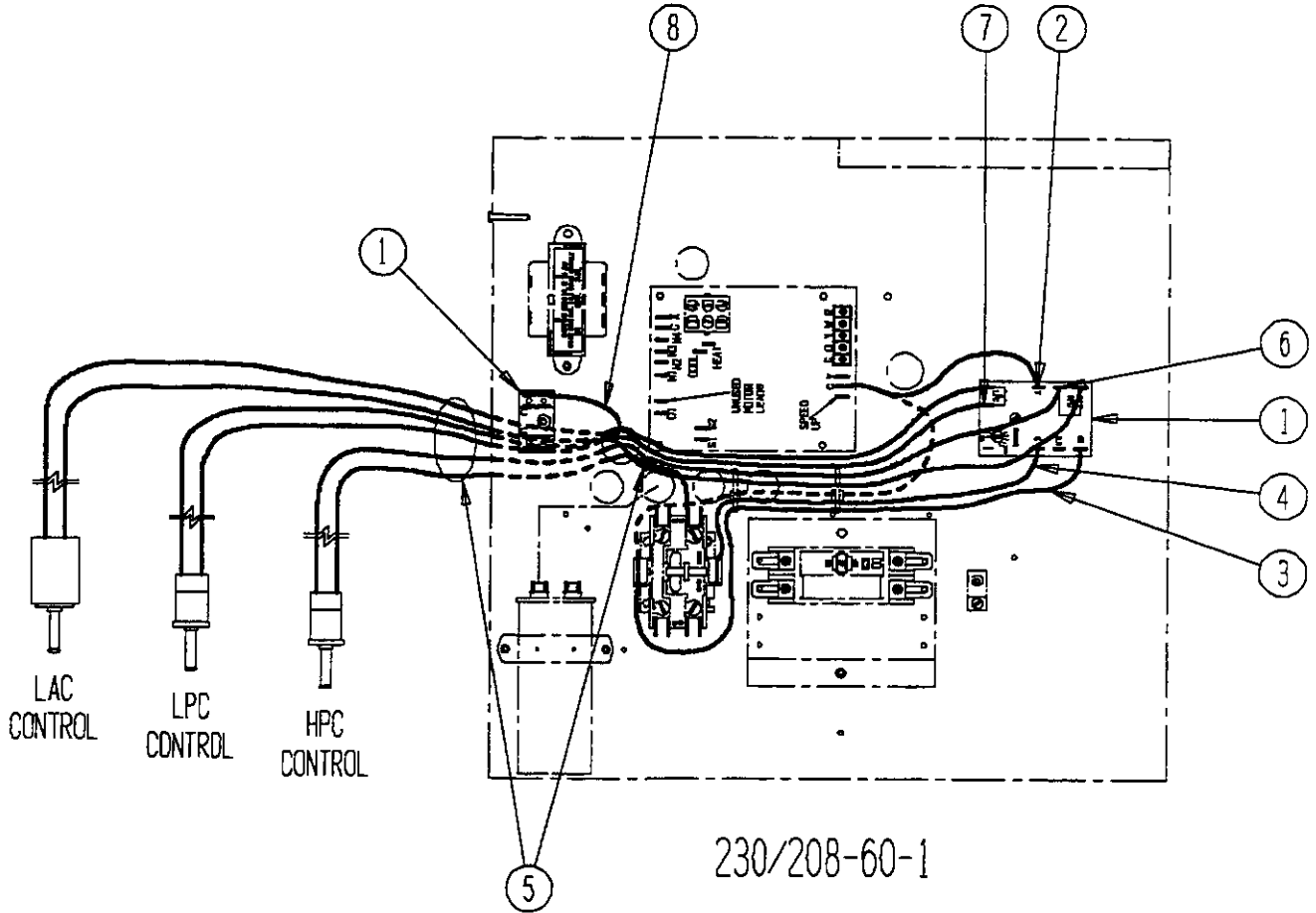

MIS-1273

FIGURE 5

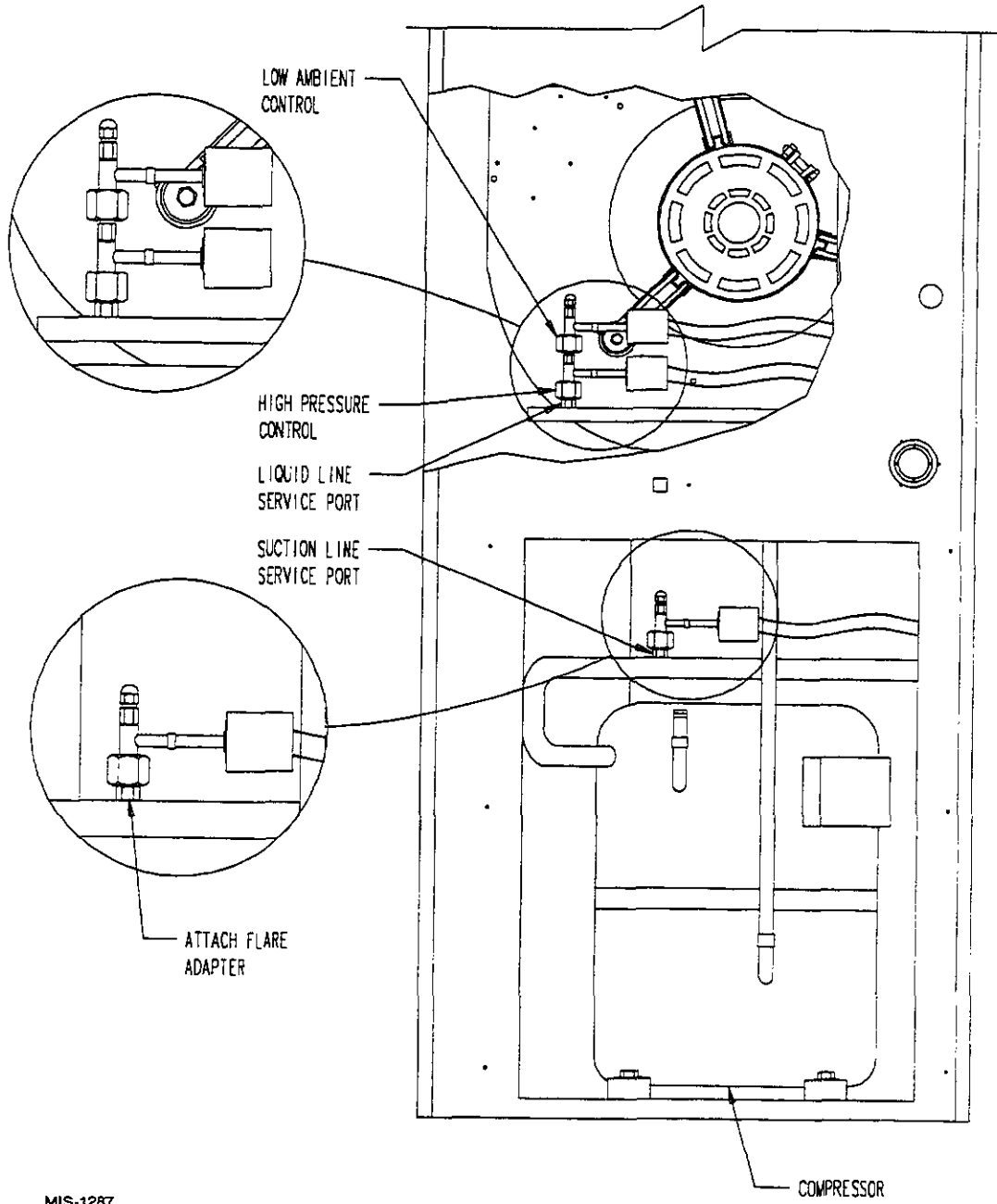

MIS-1287



Bard Manufacturing Company
Bryan, Ohio 43506

INSTALLATION INSTRUCTIONS

CMH-14

OUTDOOR THERMOSTAT KIT

DESCRIPTION

The CMH-14 is a field installable outdoor thermostat suitable for use as a compressor cutoff thermostat. This thermostat stops the compressor operation at the set temperature and brings on strip heat instead. The CMH-14 consists of:

1. Outdoor thermostat 910-1122
2. Installation Instructions 7960-246
3. CMH-14 unit label 7961-312-0008

For use with all WAWL181 – WAWL601 Hi-Boy Wall Mount Heat Pumps.

INSTALLATION INSTRUCTIONS

Disconnect all power to unit. Remove control panel inner and outer covers, and right side condenser inlet grille and front service access panel. Circled numbers on Figure 2 correspond to installation instruction steps.

Step 1. Mount outdoor thermostat 910-1122 in position shown in Figure 2, Step 1 to side of control panel with screws provided.

- Step 2. Route wires through bushing in side of control panel into the low voltage terminal strip area. See Figure 2, Step 2.
- Step 3. Route thermostat bulb through bushing in condenser partition and mount to the fan shroud with the clamps and screws provided. See Figure 2, Step 3.
- Step 4. Connect wires to the low voltage terminal strip as shown in Figure 1.
- Step 5. Recheck wiring. Refer to Figure 1. Set thermostat to the desired cutout temperature for the compressor.
- Step 6. Replace all panels and covers. This completes installation.

FIGURE 1

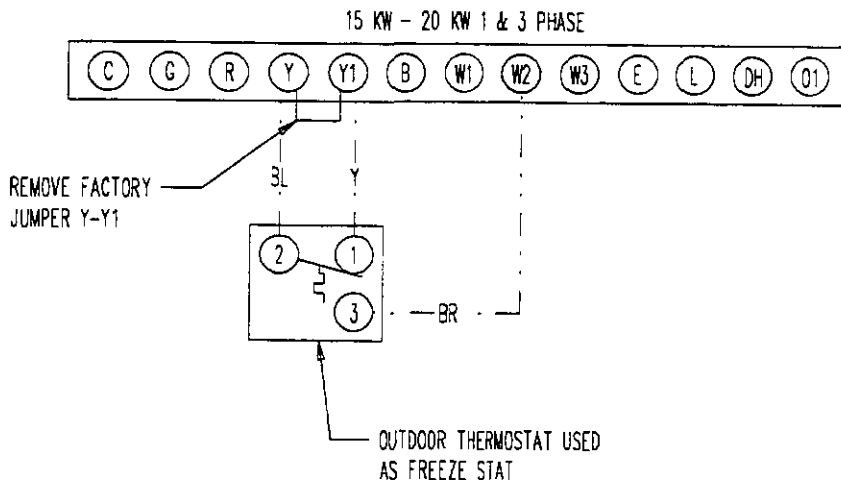
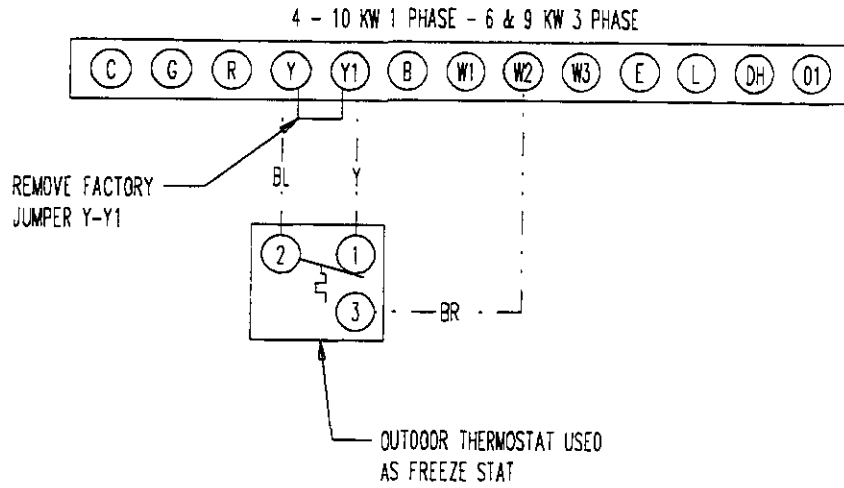

MIS-1382

FIGURE 2

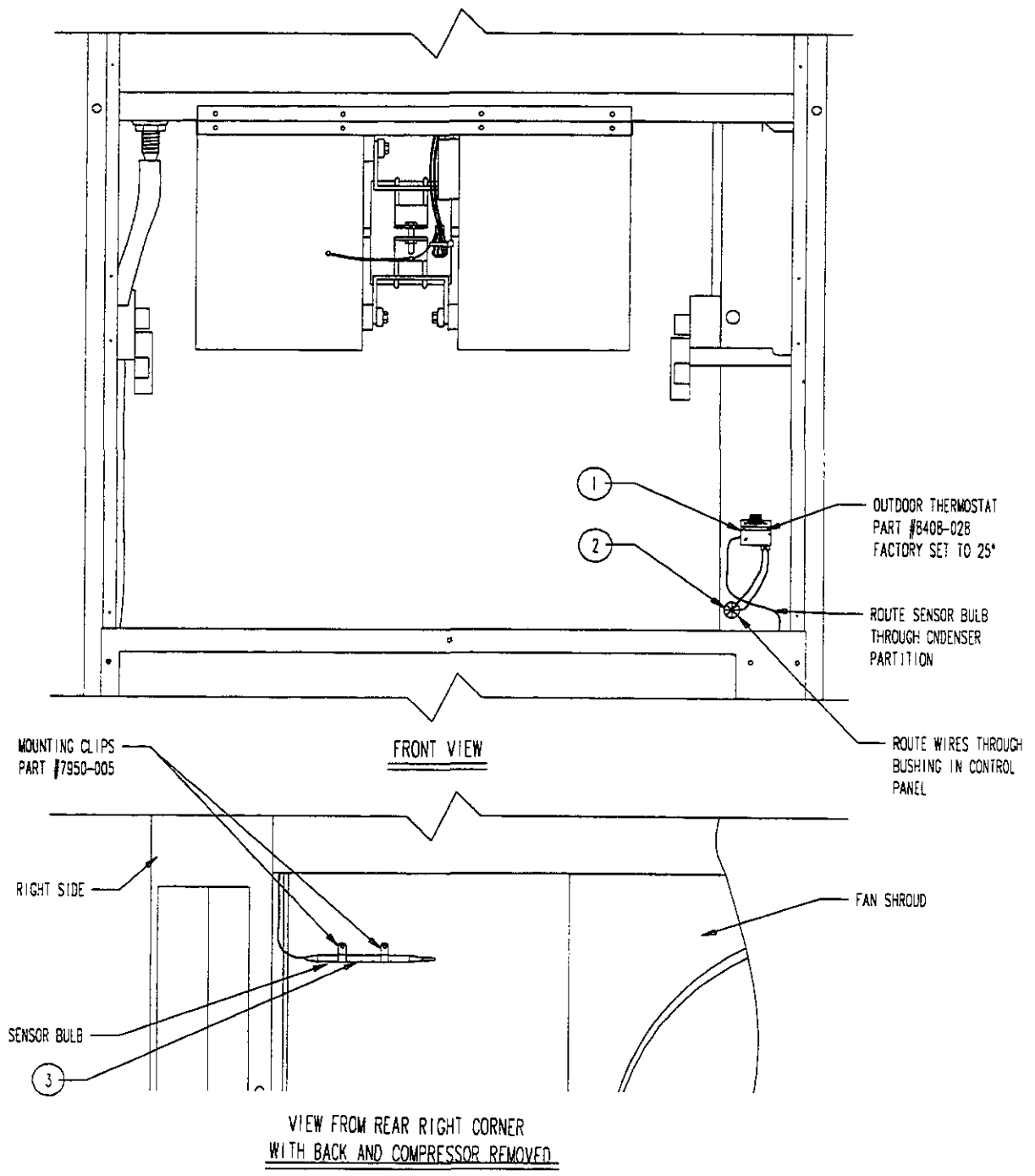

MIS-1380



Bard Manufacturing Company
Bryan, Ohio 43506

INSTALLATION INSTRUCTIONS CMC-15 START KIT

DESCRIPTION

The CMC-15 is a field installable start kit. It is a positive temperature coefficient resistor (PTCR) that increases starting torque by momentarily increasing the current to the start winding of the compressor. The CMC-15 consists of:

1. PTCR 910-1097
2. Installation Instructions 7960-245
3. CMC-15 unit label 7961-312-0009

For use with all WA/WL181 – WA/WL601 Hi-Boy Wall Mount Heat Pumps and Air Conditioners ("A" Electrical Versions ONLY).

INSTALLATION INSTRUCTIONS

Disconnect all power to unit. Remove control panel inner and outer covers. Circled numbers on Figure 1 correspond to installation instruction steps. Dashed lines indicate that a wire has been disconnected from this terminal.

- Step 1. Mount start kit (PTCR) in position shown in Figure 1, Step 1.
- Step 2. Connect wires between terminals (Herm) and (C) of dual can capacitor as shown in Figure 1, Step 2.
- Step 3. Recheck wiring. Refer to Figure 1.
- Step 4. Replace all panels and covers. This completes installation.

FIGURE 1

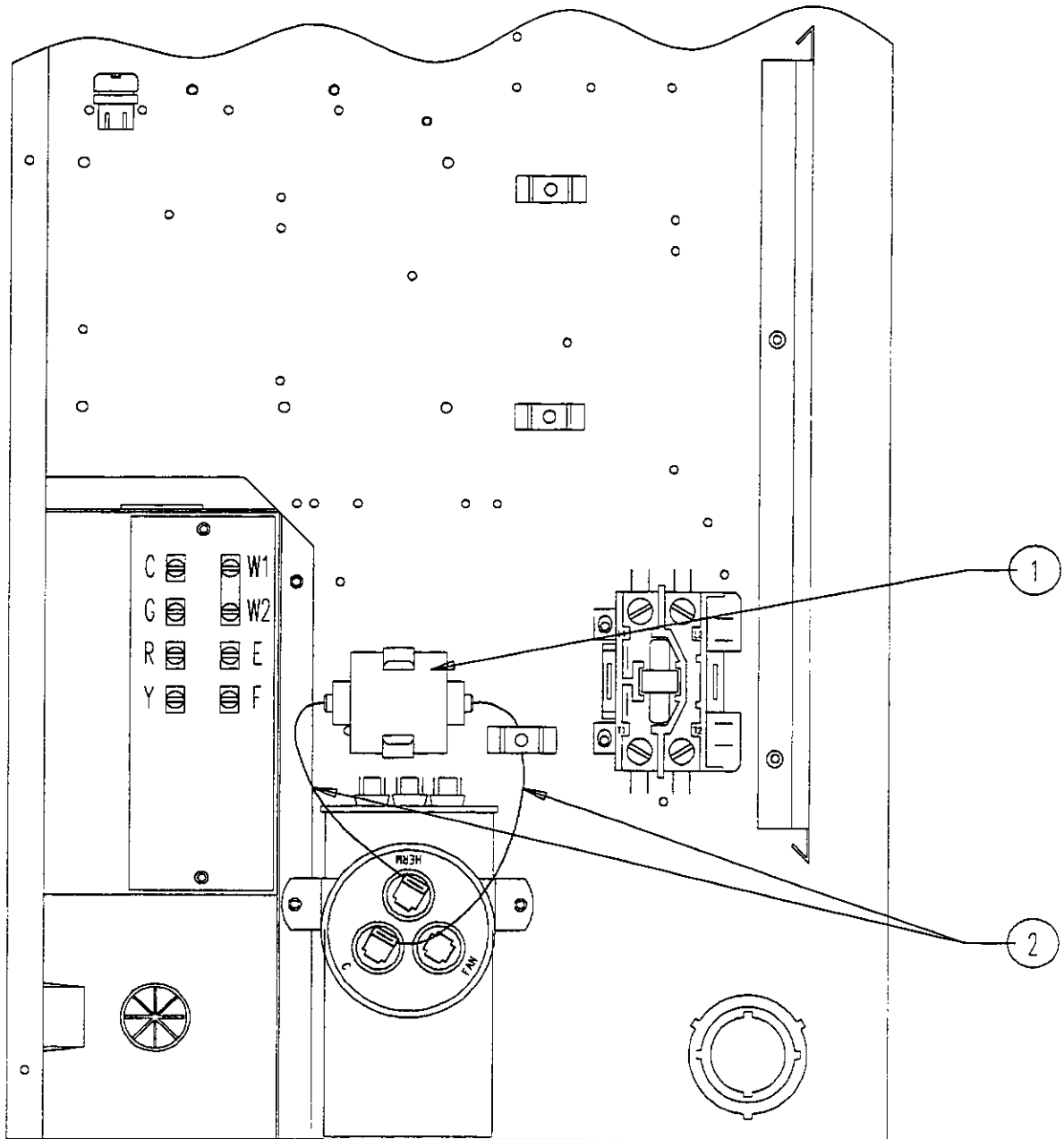

NOTE: TOP VIEW OF
CAPACITOR SHOWN

MD-1878



Bard Manufacturing Company
Bryan, Ohio 43506

INSTALLATION INSTRUCTIONS CMA-16 LOW PRESSURE CONTROL

DESCRIPTION

The CMA-16 is a field installable non-adjustable low pressure control with low pressure bypass relay. The bypass relay prevents nuisance tripping of the low pressure control during start up. The CMA-16 consists of:

1. Control assembly 910-1149
2. Low Pressure Control 1804-0107
3. Installation Instruction 7960-270
4. CMA-16 unit label 7961-312-0062

For use with all WA/WL181 – WA/WL602 Hi-Boy Wall Mount Air Conditioners.

INSTALLATION INSTRUCTIONS FOR PRE - AUGUST 1998 MODELS

Disconnect all power to unit. Remove control panel inner and outer covers, and right side condenser inlet grille. Circled numbers on Figure 2 correspond to installation instruction steps. Dashed lines indicate that a wire has been disconnected from this terminal.

- Step 1. Screw control assembly into control panel as shown in Figure 2, Step 1.
- Step 2. Disconnect yellow low voltage (Y) wire at compressor contactor coil and reconnect to terminal #3 of the low pressure bypass TDR. See Figure 2, Step 2.
- Step 3. Connect yellow wire from terminal #3 of the low pressure bypass TDR to the (Y) terminal of the compressor contactor coil. This is the terminal that the wire was removed from in Step 2. Route wires through wire holder as shown in Figure 2, Step 3.
- Step 4. Connect the black wire from terminal H of the low pressure bypass TDR to the common (C) side of the compressor contactor coil. See Figure 2, Step 4.
- Step 5. Route low (blue) pressure switch wires up through the bushing in the bottom of the control panel. Replace sealing compound after routing wires through the bushing. Route the wires through the wire holders in the control panel as shown in Figure 2. Connect the low pressure switch wires between terminal #1 and #3 of the low pressure bypass TDR. See Figure 2, Step 5.
- Step 6. Disconnect high (red) pressure switch lead from compressor contactor and reconnect to the low pressure bypass TDR terminal #1. See Figure 2, Step 6.
- Step 7. Remove service port caps on the suction line. Install the low pressure switch on the suction line with the flare tee adapter that is brazed to the low pressure switch. Check for pressure at the flare tee dill valves after installation to insure that the dill valve in the unit service port was depressed by the flare tee connector. Check for leaks at the flare tee connector. Replace service port cap on the flare tee service port and tighten. See Figure 3.
- Step 8. Recheck wiring. Refer to Figure 1. Check for proper operation of the unit by energizing in heating or cooling mode for at least 5 minutes. The unit should not go into lockout.
- Step 9. Apply "This unit equipped with CMA-16 control module" label to the inside of the inner control panel cover above the wiring diagram.
- Step 10. Replace all panels and covers. This completes installation.

INSTALLATION INSTRUCTIONS FOR POST- JULY 1998 MODELS

For use with all WAWL181 – WAWL602 Hi-Boy Wall Mount Air Conditioners.

Disconnect all power to unit. Remove control panel inner and outer covers, and right side condenser inlet grille. Circled numbers on Figure 4 correspond to installation instruction steps. Dashed lines indicate that a wire has been disconnected from this terminal.

- Step 1. Route low (blue) pressure switch wires up through the bushing in the bottom of the control panel. Replace sealing compound after routing wires through the bushing. Route the wires through the wire holders in the control panel as shown in Figure 5.
- Step 2. Remove jumper wire from LPC terminals on compressor control module (CCM).
- Step 3. Connect low pressure switch wires between terminals #1 and #3 of the low pressure bypass TDR. See Figure 4, Step 3.
- Step 4. Remove service port cap on the suction line. Install the low pressure switch on the suction line with the flare tee adapter that is brazed to the low pressure switch. Check for pressure at the flare tee dill valve after installation to insure that the dill valve in the unit service port was depressed by the flare tee connector. Check for leaks at the flare tee connector. Replace service port cap on the flare tee service port and tighten, See Figure 3.
- Step 5. Recheck wiring. See Figure 5. Check for proper operation of the unit by energizing in heating or cooling mode for at least 5 minutes. The unit should not go into lockout.
- Step 6. Apply "This unit equipped with CMA-16 control module" label to the inside of the inner control panel cover above the wiring diagram.
- Step 7. Replace all panels and covers. This completes installation.

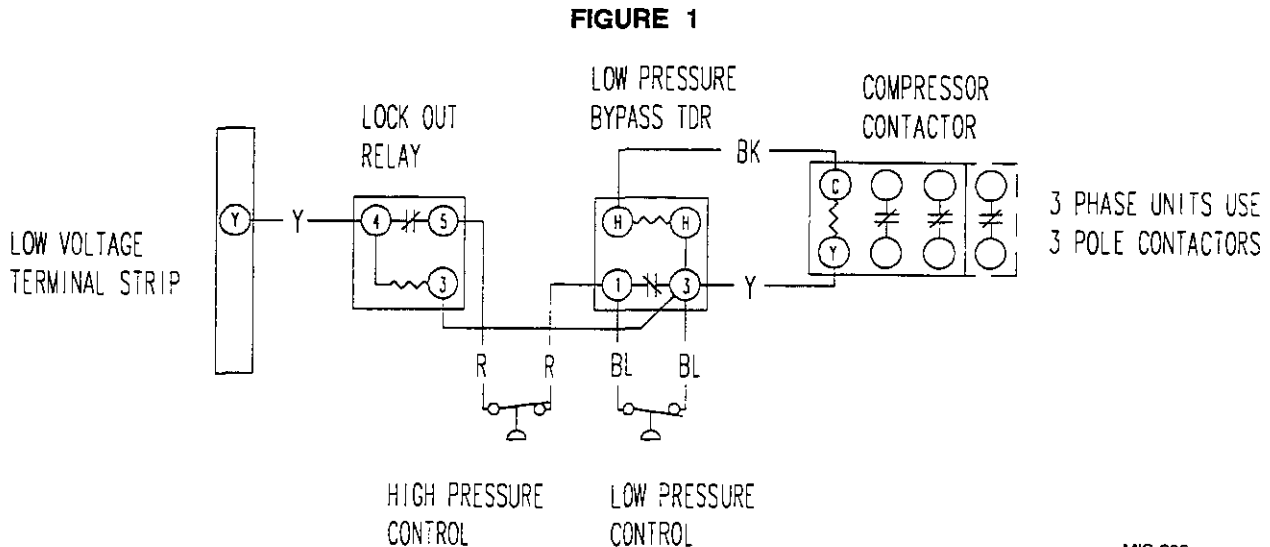

MIS-305

FIGURE 2

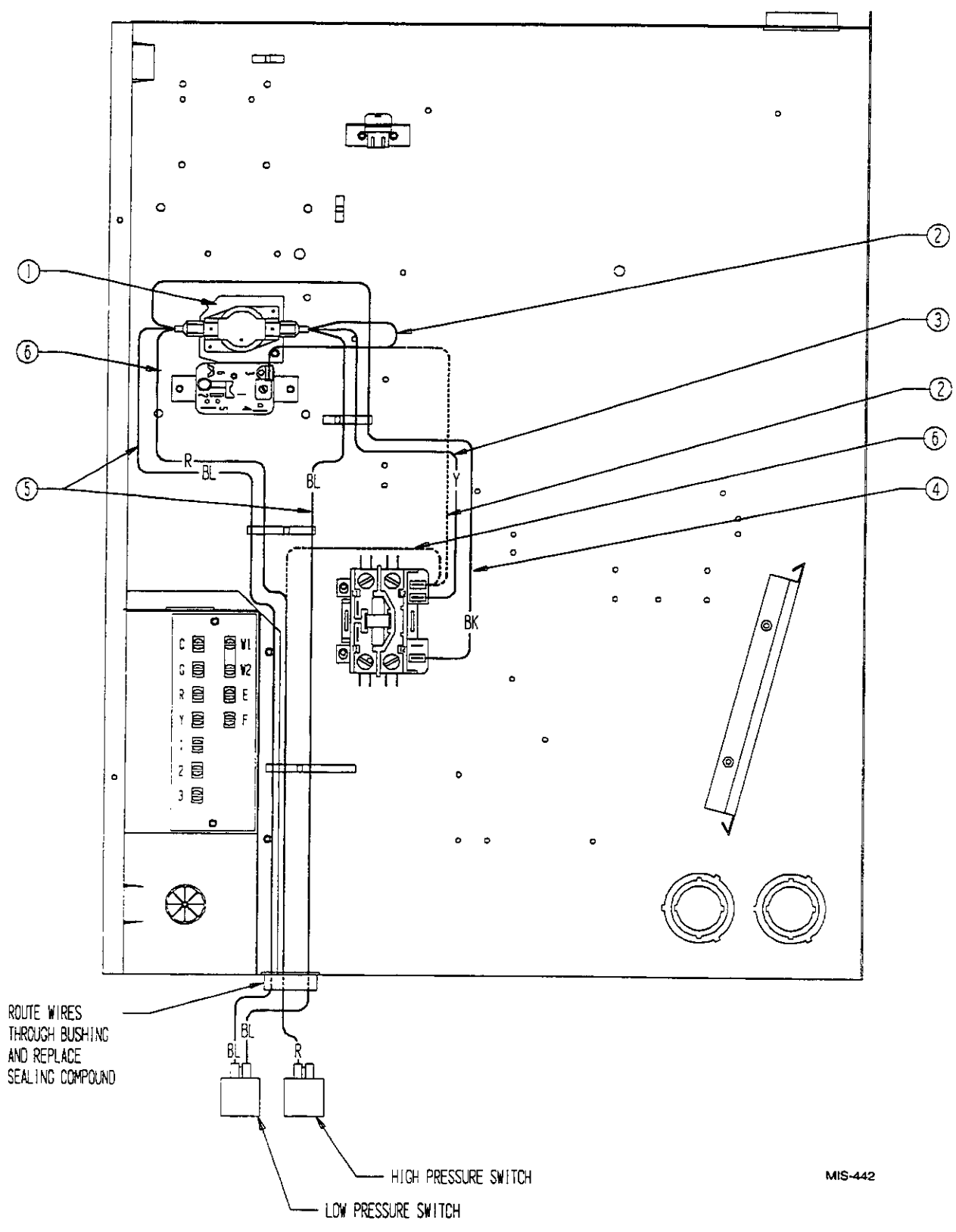

ROUTE WIRES THROUGH BUSHING AND REPLACE SEALING COMPOUND

HIGH PRESSURE SWITCH

LOW PRESSURE SWITCH

MIS-442

FIGURE 3

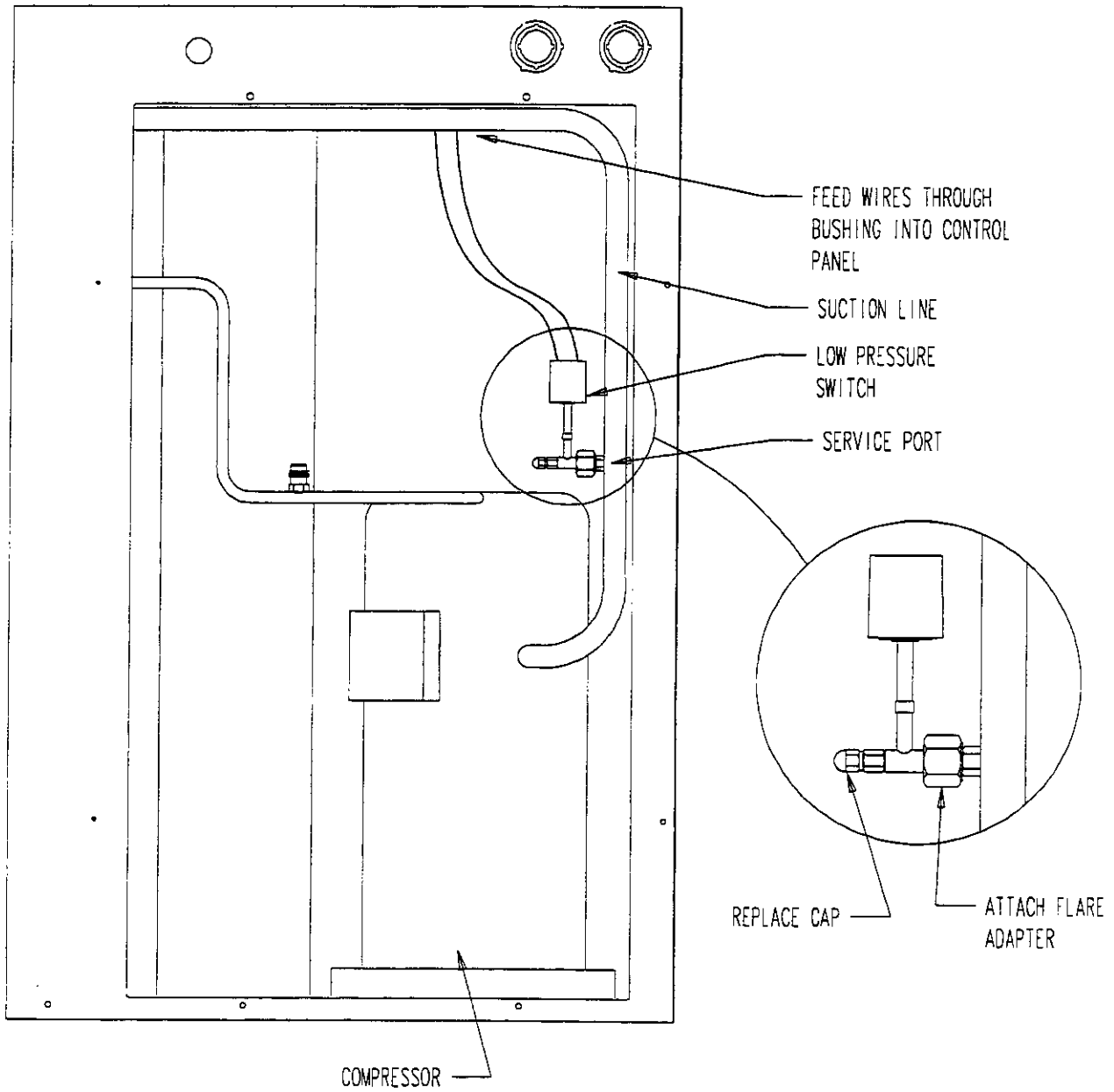

MIS-446

FIGURE 4

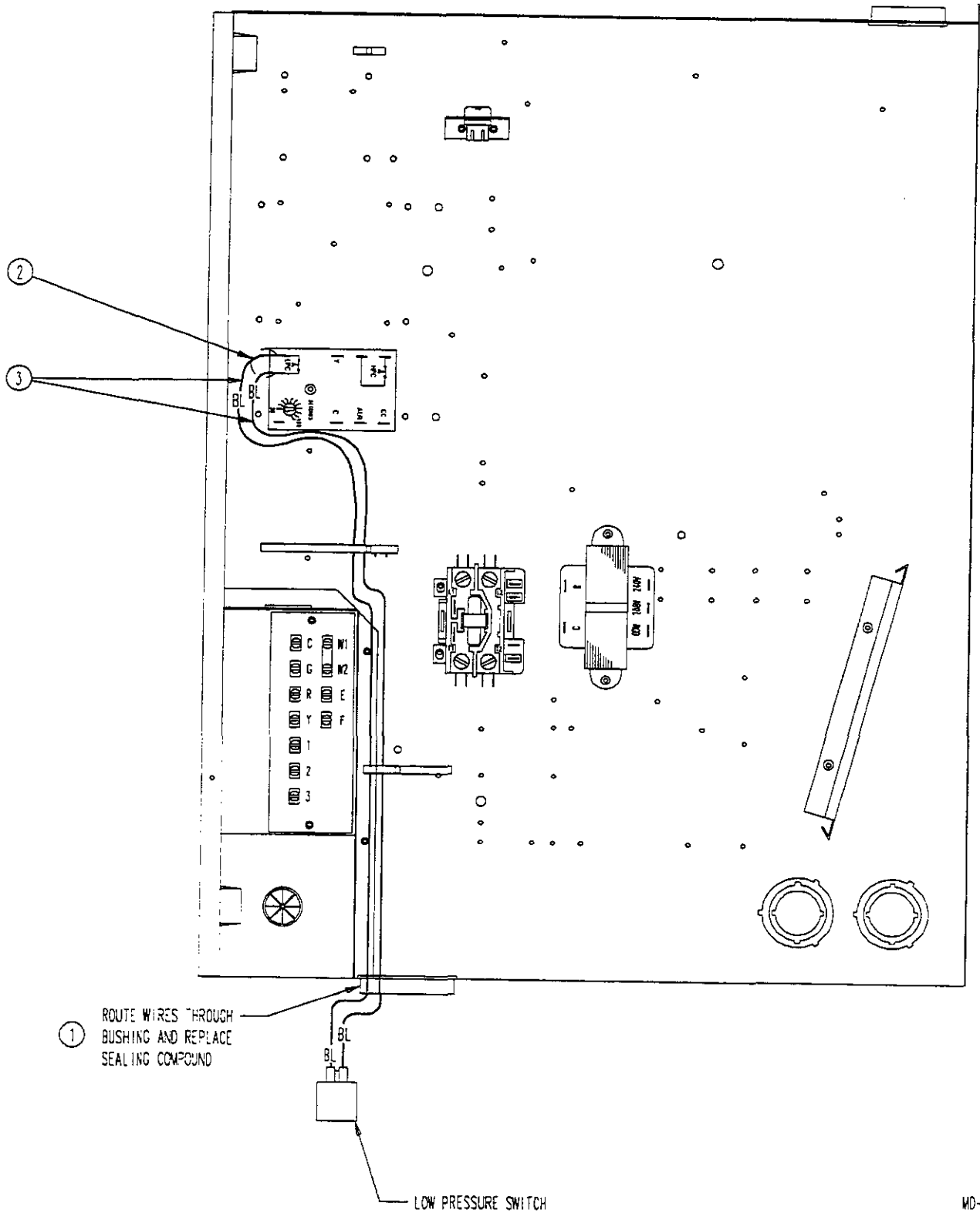

MD-29

FIGURE 5

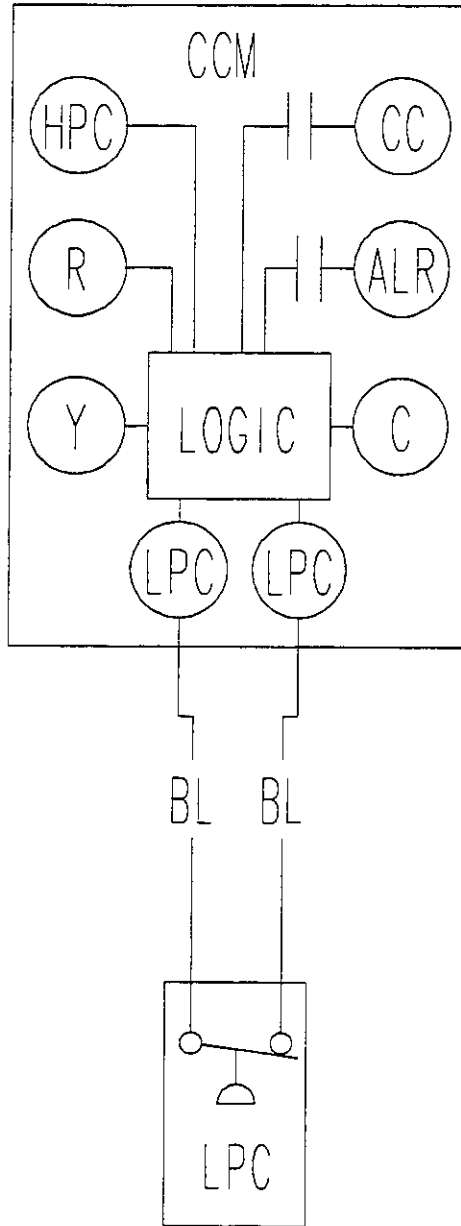

MIS-1369



Bard Manufacturing Company
Bryan, Ohio 43506

INSTALLATION INSTRUCTIONS

CMA-18

LOW PRESSURE CONTROL AND LOW AMBIENT FAN CYCLING CONTROL

DESCRIPTION

The CMA-18 is a field installable low pressure control and low ambient fan cycling control kit. The CMA-18 consists of:

1. Installation Instruction 7960-272A
2. Terminal Block 8607-017
3. Low Pressure Control 1804-0107
4. Low Ambient Fan Cycling Control 1804-0108
5. CMA-16 Unit Label 7961-312-0062

For use with all WA/WL482 – WA/WL602 Hi-Boy Wall Mount Air Conditioners (A & B ELECTRICAL VERSIONS ONLY).

INSTALLATION INSTRUCTIONS FOR PRE - AUGUST 1998 MODELS

Disconnect all power to unit. Remove control panel inner and outer covers, and right side condenser inlet grille. Circled numbers on Figure 2 correspond to installation instruction steps. Dashed lines indicate that a wire has been disconnected from this terminal.

- Step 1. Screw control assembly into control panel as shown in Figure 2, Step 1.
- Step 2. Disconnect yellow low voltage (Y) wire at compressor contactor coil and reconnect to terminal #3 of the low pressure bypass TDR. Route wires through wire holder as shown in Figure 2, Step 2.
- Step 3. Connect yellow wire from terminal #1 or (Y) of the low pressure bypass relay to the (Y) terminal of the compressor contactor coil. This is the terminal that the wire was removed from in Step 2. Route wire through wire holder as shown in Figure 2, Step 3.
- Step 4. Connect the black wire from terminal H of the low pressure bypass TDR to the common (C) side of the compressor contactor coil. See Figure 2, Step 4.

- Step 5. Route low (blue) pressure switch wires up through the bushing in the bottom of the control panel. Replace sealing compound after routing wires through the bushing. Route the wires through the wire holders in the control panel as shown in Figure 2. Connect the low pressure switch wires between terminal #1 and #3 of the low pressure bypass TDR. See Figure 2, Step 5.
- Step 6. Disconnect high (red) pressure switch lead from compressor contactor and reconnect to the low pressure bypass TDR terminal #1. See Figure 2, Step 6.
- Step 7. Mount terminal block into control with screw as shown in Figure 2, Step 7.
- Step 8. Disconnect black high voltage outdoor motor lead from compressor contactor and reconnect to terminal block. Route wires through wire holder as shown in Figure 2, Step 8.
- Step 9. Route low ambient control wires up through the bushing in the bottom of the control panel. Replace sealing compound after routing wires through the bushing. Route the wires through the wire holders in the control panel as shown in Figure 2. Connect the low ambient control wires between the terminal block and T2 of the compressor contactor. See Figure 2, Step 9.
- Step 10. Remove service port caps on both the suction and discharge line. Install the low ambient control on the discharge line with the flare tee adapter that is brazed to the control. Install the low pressure switch on the suction line. Check for pressure at the flare tee dill valves after installation to insure that the dill valve in the unit service port was depressed by the flare tee connector. Check for leaks at the flare tee connectors. Replace service port caps on the flare tee service ports and tighten. See Figure 3.

Step 11. Recheck wiring. Refer to Figure 1. Energize unit in first stage cooling. Compressor should start. Run the unit for at least 5 minutes. The unit should not go into lockout. The condenser fan motor should not run until the discharge pressure has exceeded 300 PSI. Should the discharge pressure fall below 200 PSI while running, the condenser fan motor will de-energize until the head pressure builds to 300 PSI.

Step 12. Apply "*This unit equipped with CMA-18 control module*" label to the inside of the inner control panel cover above the wiring diagram.

Step 13. Replace all panels and covers. This completes installation.

INSTALLATION INSTRUCTIONS FOR POST- JULY 1998 MODELS

For use with all WA/WL482 – WA/WL602 Hi-Boy Wall Mount Air Conditioners.

Disconnect all power to unit. Remove control panel inner and outer covers, and right side condenser inlet grille. Circled numbers on Figure 4 correspond to installation instruction steps. Dashed lines indicate that a wire has been disconnected from this terminal.

Step 1. Route low (blue) pressure switch wires up through the bushing in the bottom of the control panel. Replace sealing compound after routing wires through the bushing. Route the wires through the wire holders in the control panel as shown in Figure 4.

Step 2. Remove jumper wire from LPC to LPC on compressor control module (CCM).

Step 3. Connect low pressure switch wires between terminals #1 and #3 of the compressor control module (CCM). See Figure 3, Step 2.

Step 4. Mount terminal block into control with screw as shown in Figure 4, Step 4.

Step 5. Disconnect black high voltage outdoor motor lead from compressor contactor and reconnect to terminal block. Route wires through wire holder as shown in Figure 4, Step 5.

Step 6. Route low ambient control wires up through the bushing in the bottom of the control panel. Replace sealing compound after routing wires through the bushing. Route the wires through the wire holders in the control panel as shown in Figure 4. Connect the low ambient control wires between the terminal block and T2 of the compressor contactor. See Figure 4, Step 6.

Step 7. Remove service port caps on both the suction and discharge line. Install the low ambient control on the discharge line with the flare tee adapter that is brazed to the control. Install the low pressure switch on the suction line. Check for pressure at the flare tee dill valves after installation to insure that the dill valve in the unit service port was depressed by the flare tee connector. Check for leaks at the flare tee connectors. Replace service port caps on the flare tee service ports and tighten. See Figure 3.

Step 8. Recheck wiring. Refer to Figure 5. Energize unit in first stage cooling. Compressor should start. Run the unit for at least 5 minutes. The unit should not go into lockout. The condenser fan motor should not run until the discharge pressure has exceeded 300 PSI. Should the discharge pressure fall below 200 PSI while running, the condenser fan motor will de-energize until the head pressure builds to 300 PSI.

Step 9. Apply "*This unit equipped with CMA-18 control module*" label to the inside of the inner control panel cover above the wiring diagram.

Step 10. Replace all panels and covers. This completes installation.

FIGURE 1

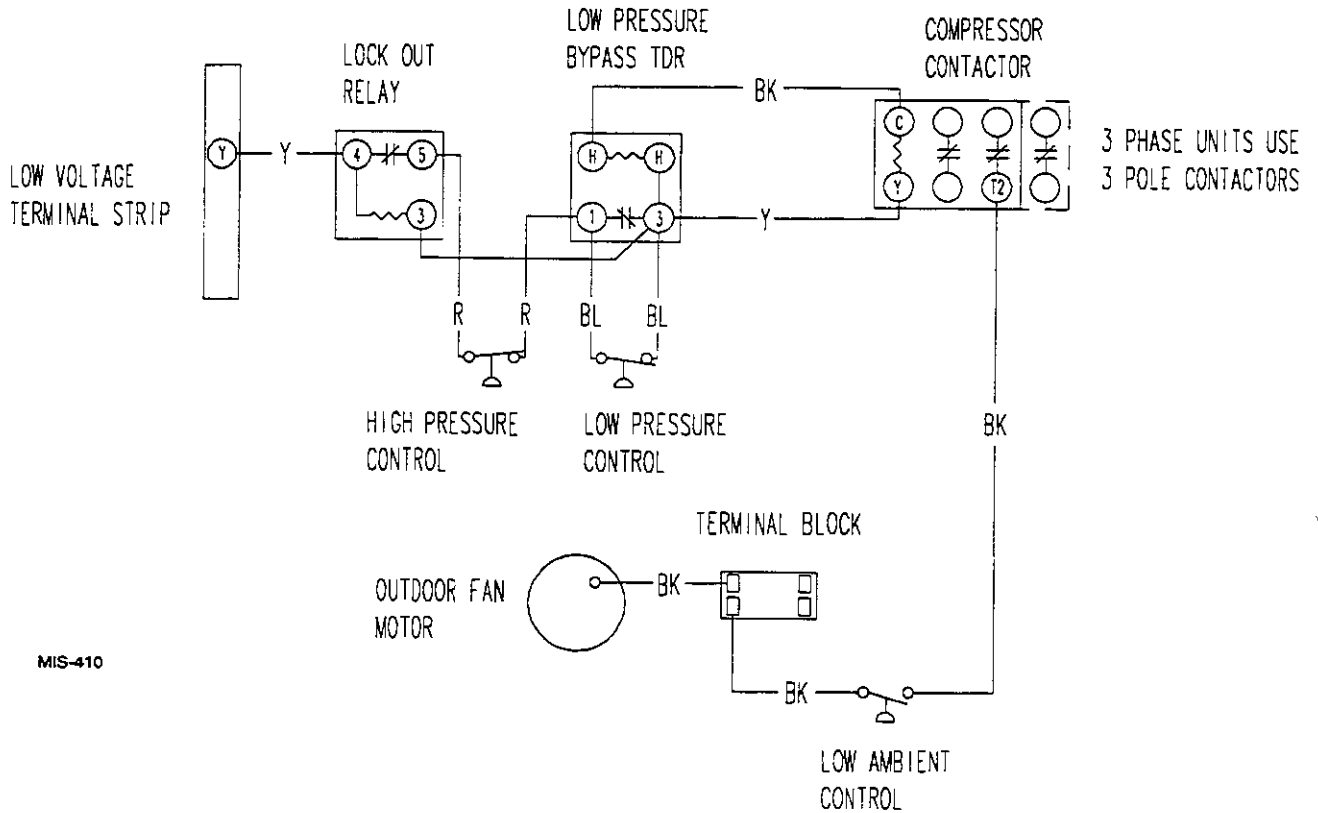

MIS-410

FIGURE 2

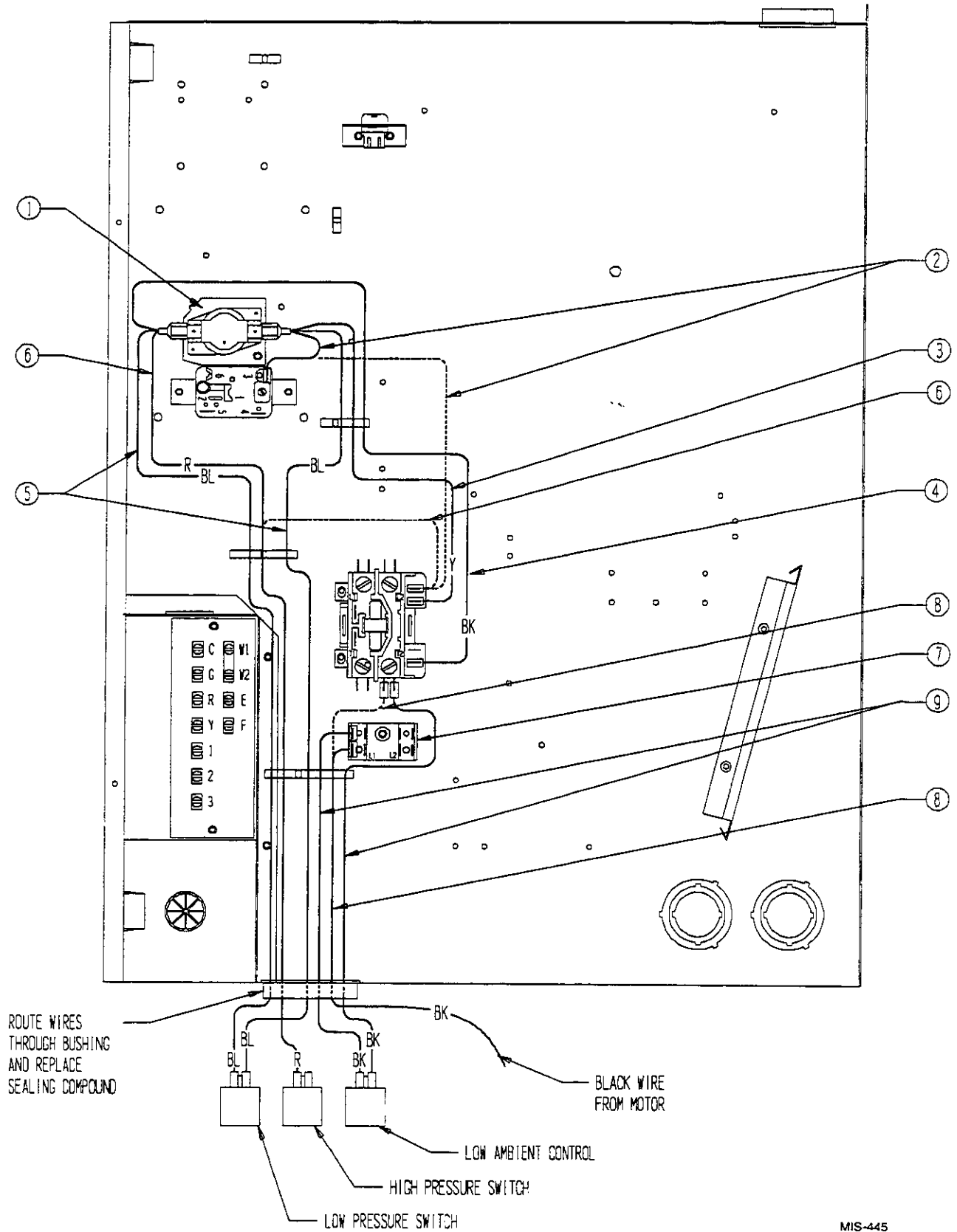

MIS-445

FIGURE 3

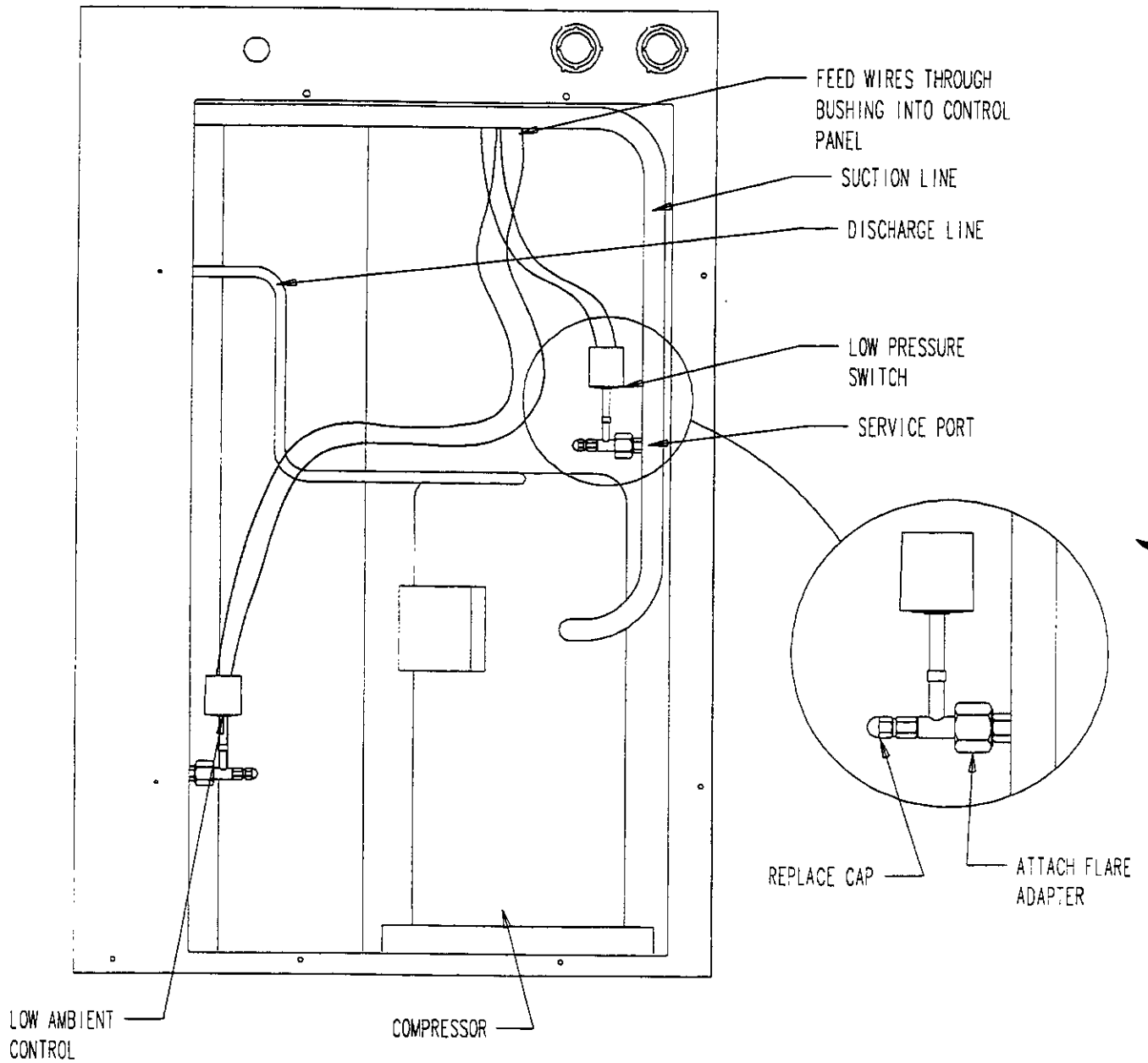

MIS-448

FIGURE 4

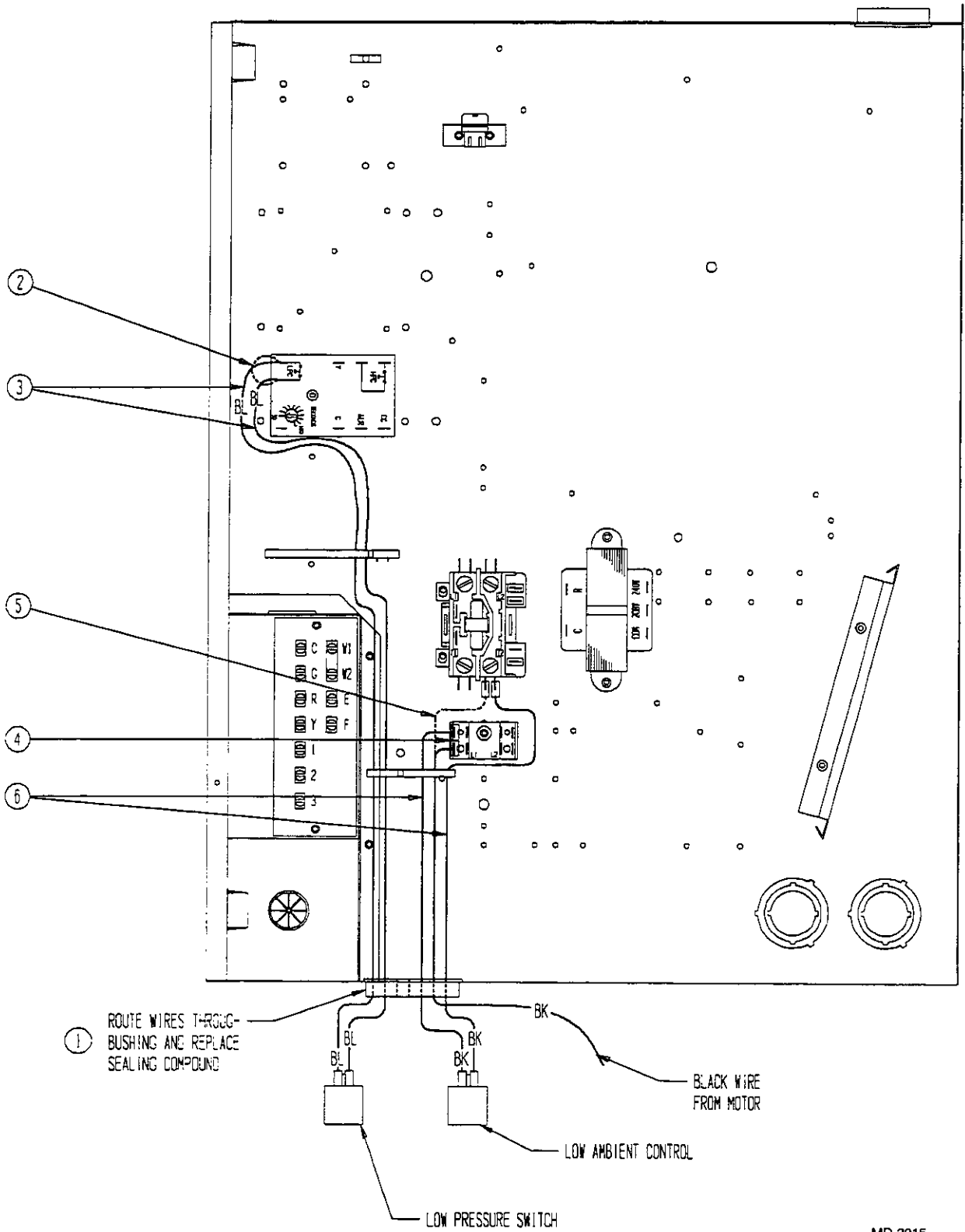

MD-2915

FIGURE 5

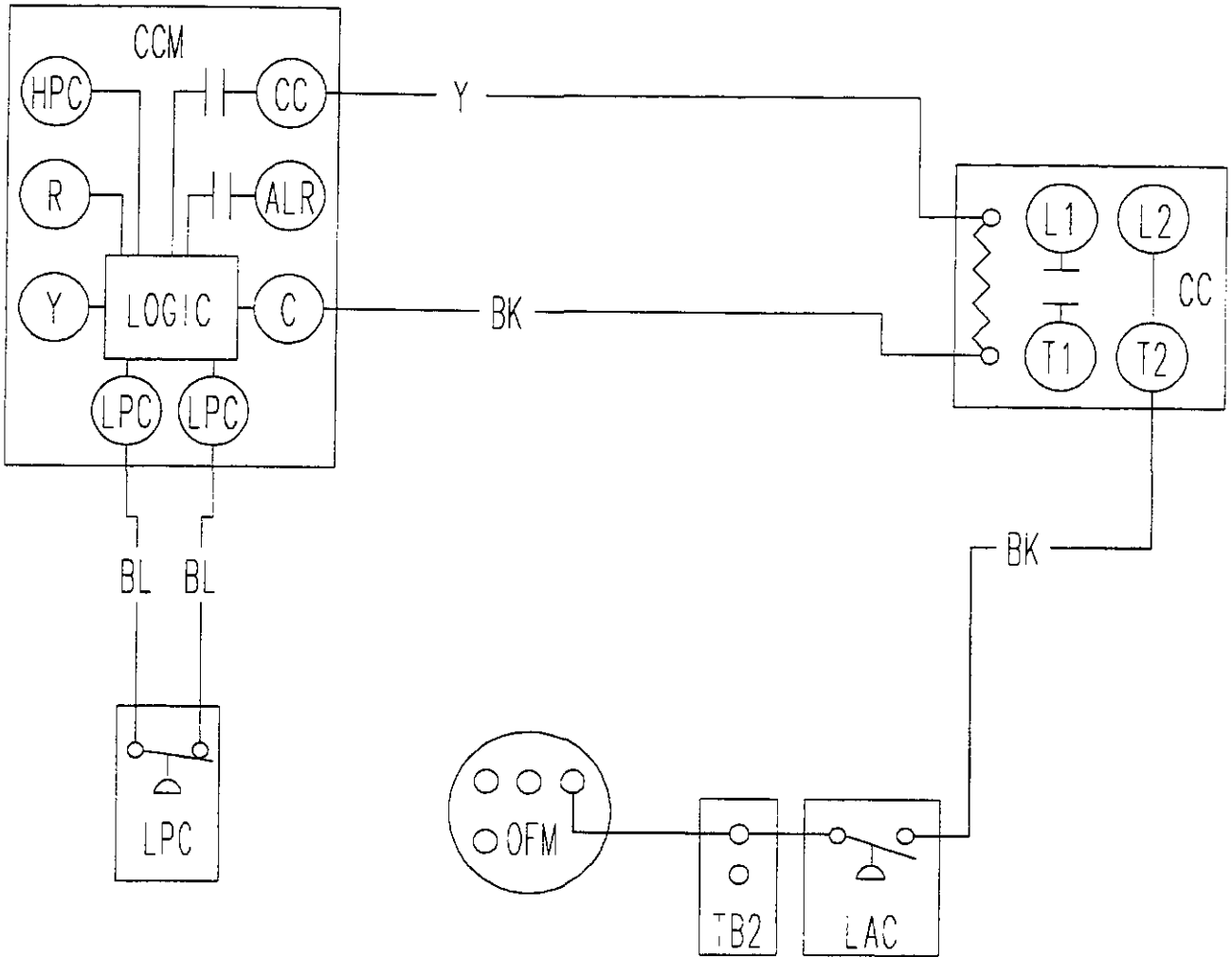

MIS-1370