

INSTALLATION INSTRUCTIONS

SINGLE PACKAGE HEAT PUMPS

MODELS

PH11421

PH1048

PH1060

**FOR RESIDENTIAL AND COMMERCIAL
HEATING/COOLING APPLICATIONS**

**MANUAL 2100-227 REV.
SUPERSEDES REV.
FILE VOL. II, TAB 11**

SECTION 1 --GETTING OTHER INFORMATION AND PUBLICATIONS

These publications can help you install the air conditioner or heat pump. You can usually find these at your local library or purchase them directly from the publisher. Be sure to consult current edition of each standard.

National Electrical Code	-ANSI/NFPA 70
Standard For The Installation Of Air Conditioning and Ventilating Systems	-ANSI/NFPA 90A
Standard For Warm Air Heating and Air Conditioning Systems	-ANSI/NFPA 90B
Load Calculation For Residential Winter and Summer Air Conditioning	-ACCA Manual J
Duct Design For Residential Winter and Summer Air Conditioning and Equipment Selection	-ACCA Manual D

FOR MORE INFORMATION, CONTACT THESE PUBLISHERS

ACCA:	AIR CONDITIONING CONTRACTORS OF AMERICA 1513 16th Street NW Washington, DC 20036 Telephone: (202) 483-9370	Fax: (202) 234-4721
ANSI:	AMERICAN NATIONAL STANDARDS INSTITUTE 11 West Street, 13th Floor New York, NY 10036 Telephone: (212) 642-4900	Fax: (212) 302-1286
ASHRAE:	AMERICAN SOCIETY OF HEATING REFRIGERATING AND AIR CONDITIONING ENGINEERS, INCORPORATED 1791 Tullie Circle, N.E. Atlanta, GA 30329-2305 Telephone: (404) 636-8400	Fax: (404) 321-5478
NFPA:	NATIONAL FIRE PROTECTION ASSOCIATION Batterymarch Park P. O. Box 9101 Quincy, MA 02269-9901 Telephone: (800) 344-3555	Fax: (617) 984-7057

TABLE OF CONTENTS

I.	General Instructions	1
	A. Important	2
	B. Shipping Damage	2
	C. General	2
	D. Field Installed Heater Packages (Optional).	3
	E. Roof Curbs (Optional)	4
II.	Installation.	5
	A. Location.	5
	B. Typical Installations	7
	C. Condensate Drain Trap	8
	D. Air Filters	8
	E. Wiring.	8
	1. Main Power.	8
	2. 24V Low Voltage Control Circuit	9
	3. Thermostats	9
	A. Thermostat Indicator Lights	10
	B. Emergency Heat Position	10
	4. Transformer Taps.	10
	5. Compressor Cut-Off Thermostat & Outdoor Thermostat Wiring	10
	A. Compressor Cut-off Wiring	11
	B. Compressor Cut-off & Outdoor Thermostat Wiring.	11
III.	Startup and Operation	12
	A. Three Phase Scroll Compressor Startup Information	12
	B. Sequence of Operation	12
	C. Defrost Cycle	12
	D. Startup Notes	13
IV.	Service and Troubleshooting	13
	A. Service Hints	13
	B. Pressure Service Ports.	14
	C. Refrigerant Charge.	14
	D. Fan Blade Settings.	14
	E. Solid State Heat Pump Control Troubleshooting Procedure	15
	F. Temperature Sensor Checkout	16
	G. Suction and Discharge Tube Brazing.	17
	H. Discharge (Top Cap) Thermostat.	17
	I. Pressure Tables	19

FIGURES AND TABLES

Figure 1	4
Figure 2	4
Figure 3	6
Figure 4	6
Figure 5	6
Figure 6	6
Figure 7	8
Figure 8	9
Figure 9	11
Figure 10.	11
Figure 11.	13
Figure 12.	14
Figure 13.	17
Figure 14.	18
Figure 15.	18

Table 1	1
Table 2	1
Table 3	2
Table 4	3
Table 5	5
Table 5A	5
Table 6	8
Table 7	9
Table 8	9
Table 9	11
Table 10	11
Table 11	14
Table 12	19
Table 13	19

TABLE 1
ELECTRICAL DATA

Model	Rated Volts & PH	Operating Voltage Range	Max. Unit Amps	Req'd. Maximum	Minimum	Field	Ground
				External Fuses Or Ckt. Brk *	Circuit Ampacity	Power Wiring**	Wire Size**
				Ckt. A	Ckt. A	Ckt. A	Ckt. A
PH11421	230/208-1	197-253	24.1	50	31	8	10
PH1048	230/208-1	197-253	26.9	50	36	8	10
PH1048-B	230/208-3	187-253	17.5	35	23	8	10
PH1048-C	460-3	414-506	8.6	20	13	12	12
PH1060	230/208-1	197-253	32.5	60	42	8	10
PH1060-B	230/208-3	187-253	22.8	45	28	8	10
PH1060-C	460-3	414-506	11.0	20	14	12	12

*Maximum time delay fuse or HACR type circuit breaker. HACR type not applicable to 460 volt.
**75°C copper wire size, basic unit only.

TABLE 2
OPTIONAL FIELD INSTALLED HEATER PACKAGES
ARE ONLY TO BE USED WITH THE HEAT PUMP MODELS AS INDICATED BELOW

Heater Package Model No.	Volts and Phase	P	P	P	P	P	P	P
		H	H	H	H	H	H	H
		1	1	1	1	1	1	1
		1	0	0	0	0	0	0
		4	4	4	4	6	6	6
		2	8	8	8	0	0	0
		1			1			
				B	C		B	C
EH5PB-A05	240/1	S	S	A	A	S	A	A
EH5PB-A10		S	S	A	A	S	A	A
EH5PB-A15		S	S	A	A	S	A	A
EH5PB-A20		S	S	A	A	S	A	A
EH5PB-B09	240/3		A	S	A	A	S	A
EH5PB-B15			A	S	A	A	S	A
EH5PB-B18			A	S	A	A	S	A
EH5PB-C09	480/3		A	A	S	A	A	S
EH5PB-C15			A	A	S	A	A	S
EH5PB-C18			A	A	S	A	A	S

S Standard application--Heater volts and phase same as basic unit.
A Alternate application--Heater volts and phase different from basic unit.

TABLE 3
OPTIONAL FIELD-INSTALLED ELECTRIC HEATER TABLE

Heater Pkg. Model No.	Unit Volts Phase	Htr. KW & Cap. @240V (or 480V if applicable)		Heater KW & Capacity @208 Volts		@240V or 480V as Applicable Htr. Amps	Heater Internal Fuses	Circuit B				
								No. Field Ckts.	Minimum Circuit Ampacity	(1) Maximum Overcurrent Protection	(2) Field Power Wiring	(3) Ground Wire Size
EH5PB-A05	240/208-1	5	17,100	3.75	12,800	20.8		1	26	30	10	10
EH5PB-A10	240/208-1	10	34,100	7.5	26,000	41.7		1	53	60	6	10
EH5PB-A15	240/208-1	15	51,200	11.25	38,400	62.5	30/60	1	79	80	4	8
EH5PB-A20	240/208-1	20	68,200	15	51,200	83.2	60/60	1	104	110	2	6
EH5PB-B09	240/208-3	9	30,700	6.75	23,000	21.7		1	28	30	10	10
EH5PB-B15	240/208-3	15	51,200	11.25	38,400	36.2		1	46	50	8	10
EH5PB-B18	240/208-3	18	61,400	13.5	46,100	43.4		1	55	60	6	10
EH5PB-C09	460-3	9	30,700	6.75	23,000	10.8		1	15	15	14	14
EH5PB-C15	460-3	15	51,200	11.25	38,400	18.0		1	23	25	10	10
EH5PB-C18	460-3	18	61,400	13.5	46,100	21.7		1	28	30	10	10

- (1) Time delay fuses or "HACR Type" circuit breakers must be used for 60 and smaller sizes. Standard fuses or circuit breakers are suitable for sizes 70 and larger. 480V circuit breakers are not "HACR Type".
- (2) Based on wire suitable for 75°C. Other wiring materials must be rated for marked "Minimum Circuit Ampacity" or greater.
- (3) Based upon Table 250-95 of N.E.C. 1993. See electrical data for basic heat pump for Ckt. A wiring specification requirements.

IMPORTANT: While this electrical data is presented as a guide, it is important to electrically connect, properly size fuses and conductor wires in accordance with the National Electrical Code and all existing local codes.

GENERAL INSTRUCTIONS

IMPORTANT

The equipment covered in this manual is to be installed by trained, experienced service and installation technicians. Any heat pump is more critical of proper operating charge and an adequate duct system than a straight air conditioning unit. All duct work, supply and return, must be properly sized for the design air flow requirement of the equipment. ACCA is an excellent guide to proper sizing. All duct work or portions thereof not in the conditioned space should be properly insulated in order to both conserve energy and prevent condensation or moisture damage.

SHIPPING DAMAGE

Upon receipt of equipment, the carton should be checked for external signs of shipping damage. If damage is found, the receiving party must contact the last carrier immediately, preferably in writing, requesting inspection by the carrier's agent.

GENERAL

The refrigerant system is completely assembled and charged. All internal wiring is complete.

The unit is designed for use with or without duct work. Flanges are provided for attaching the supply and return ducts.

These instructions explain the recommended method to install the air cooled self-contained unit and the electrical wiring connections to the unit.

These instructions and any instructions packaged with any separate equipment required to make up the entire air conditioning system should be carefully read before beginning the installation. Note particularly "Starting Procedure" and any tags and/or labels attached to the equipment.

While these instructions are intended as a general recommended guide, they do not supersede any national and/or local codes in any way. Authorities having jurisdiction should be consulted before the installation is made.

FIELD INSTALLED HEATER PACKAGES (OPTIONAL)

These packaged heat pumps are manufactured without supplementary electric heaters. Supplementary heaters RH5PB series (to fit PH11421, PH1048, and PH1060) are available for simple, fast, field installation.

A separate field power circuit is required for the supplementary heaters.

IMPORTANT: Refer to Tables 4 and 5 when designing ductwork for maximum available static pressure with heater installed.

Refer to the electrical data shown on pages 1 and 2 for proper application information on all available heater combinations and what units they can be used with. It also shows the applicable circuit ampacities, fuse size, and wire size for each heater combination.

Refer to the installation instructions packed with the heater for details on how to insert it into the basic unit.

TABLE 4
MAXIMUM ESP OF OPERATION

	PH11421	PH1048	PH1060
A00	.50	.50	.50
A05	.40	.50	.50
A10	.35	.50	.50
*A15	.35	.50	.50
*A20	.35	.50	.50
B00	---	.50	.50
B09	---	.50	.50
*B15	---	.50	.50
*B18	---	.50	.50
C00	---	.50	.50
C09	---	.50	.50
*C15	---	.50	.50
*C18	---	.50	.50

N/A - Not applicable.

NOTE: *Maximum electric heat with heat pump is 10KW.
On higher KW's, the remaining KW is used during
compressor cutout or emergency heat only.

PREFABRICATED ROOF CURB SPECIFICATIONS
HEAVY GAUGE GALVANIZED WITH WOOD NAILING STRIP, WELDED/LEAKPROOF
ONE PIECE CONSTRUCTION--READY TO INSTALL

FIGURE 1

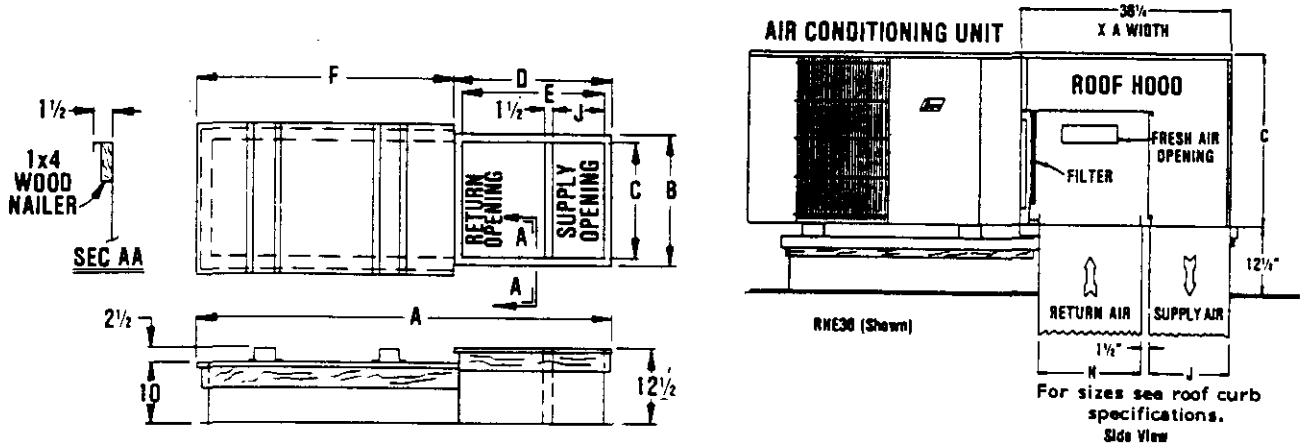

CURB AND ROOF HOOD DETAILS

	A	B	C*	D	E	F	J*	H*	Roof Hood Model	Heat Pump Units
9042-004	82-3/8	44-1/8	41-1/8	38-3/8	35-3/8	44	14-3/4	19-1/8	RHE60	PH11421, PH1048, PH1060

* Duct Sizing Information

Return Air Dimension "C" is length
 Return Air Dimension "H" is width

Supply Air Dimension "C" is length
 Supply Air Dimension "J" is width

FIELD FABRICATED CURBING

FIGURE 2

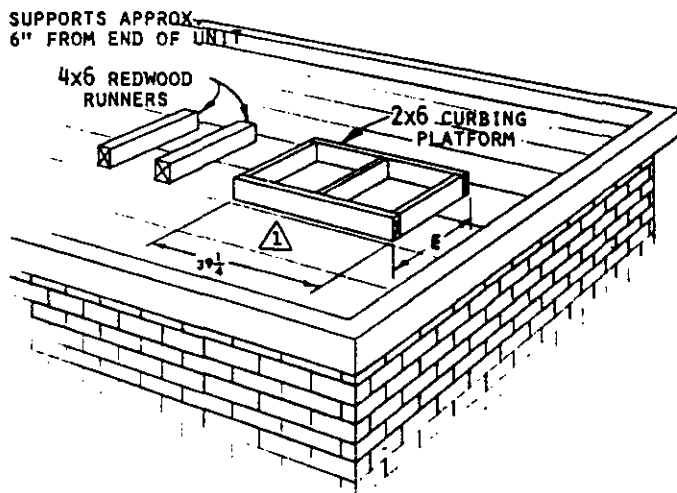

Roof Hood Model	Unit Model	E
RHE60	PH11421 PH1048 PH1060	44-7/8

- (1) A separate metal flashing should be installed around wood curbing. Caulk and seal all joints and weatherproof.

INSTALLATION

LOCATION

GENERAL--The unit must be located outside, or in a well ventilated area. It must not be in the space being heated or cooled. A sound absorbing material should be considered if the unit is to be installed in such a position or location that might cause transmission of sound or vibration to the living area or adjacent buildings.

SLAB MOUNTING--In areas where winter temperatures DO NOT go below 32°F for periods over twelve hours, the unit may be slab mounted at grade level. When installing unit at grade level, install on a concrete slab at least four inches above finished grade level. Slab should have a slope tolerance away from the building structure of at least 1/4 inch per foot, while being level from side to side. This will prevent ice buildup under the unit during defrost cycles. Place slab in a location where run-off water from higher ground will not collect around unit. See Figure 4.

A minimum of 18 inches should be provided between the coil inlet and any building surfaces. Provide at least four feet between coil outlet and any building wall, fences or other vertical structures. Provide a minimum of three feet clearance on the service access side of the unit. See Figure 6.

ROOF MOUNTING--When a unit is installed in areas where low ambient temperatures or strong winter winds exist, it should be placed so prevailing winter winds are not in direct line with the heat pump coil. If this is not possible, a wind barrier should be constructed. Place barrier 24 inches from the coil inlet side of the unit and in the direction of prevailing winds. Size barrier at least the same height and width as the unit. This may be necessary on ground level installations. See Figure 3.

WINTER INSTALLATION BELOW 32°F--In areas where winter conditions go below 32°F for extended periods, the unit must be elevated above the mounting surface to prevent snowfall or defrost ice accumulation from interfering with the operation of the unit. A minimum of twelve inch elevation is recommended, while greater elevation may be required for areas of high snow accumulation. Poured concrete, steel framework, brick, cement block, etc., can be utilized to construct a suitable raised mounting platform. See Figure 5.

DUCTWORK--Refer to Tables 4, 5 and 5A when designing ductwork for maximum static pressure available with the specific model and heater package being installed.

TABLE 5
RATED CFM AND EXTERNAL STATIC PRESSURE (ESP)
WET COIL (COOLING)

Model	Rated CFM	Rated ESP	Recommended Air Flow Range
PH1421	1400	.20	1260 - 1540 CFM
PH1048	1550	.40	1400 - 1700 CFM
PH1060	1700	.20	1530 - 1870 CFM

TABLE 5A

BSP Inches B20	P1142A2 PH1421 Dry/Wet	P1148A1 PH1048 Dry/Wet	P1048A1 PH160 Dry/Wet
0	1650/1625	1950/1920	1850/1850
.1	1550/1525	1860/1830	1800/1780
.2	1435/1400	1780/1750	1725/1700
.3	1340/1310	1680/1660	1660/1625
.4	1230/1210	1580/1550	1580/1540
.5	1120/1100	1500/1480	1500/1475

Figure 5
SLAB MOUNTING AT GROUND LEVEL
(Above 32°F Outside Temperature)

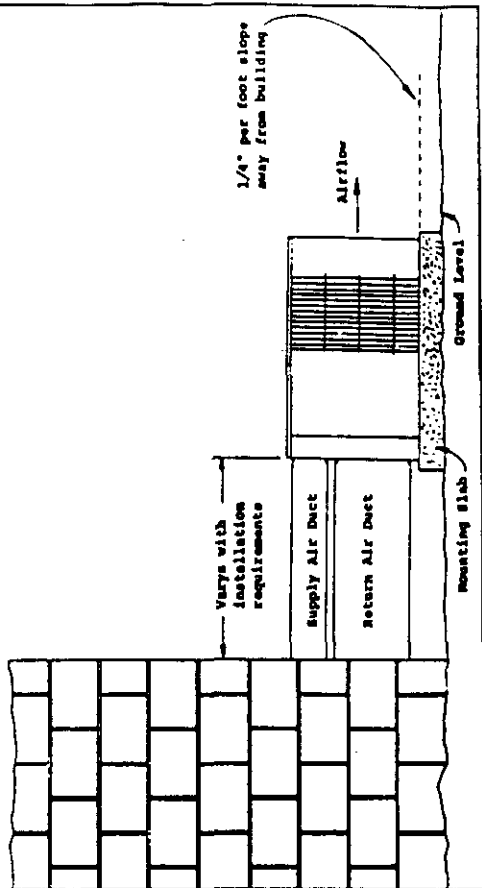

Figure 3
ROOFTOP APPLICATION

(May also be required for ground level installations)

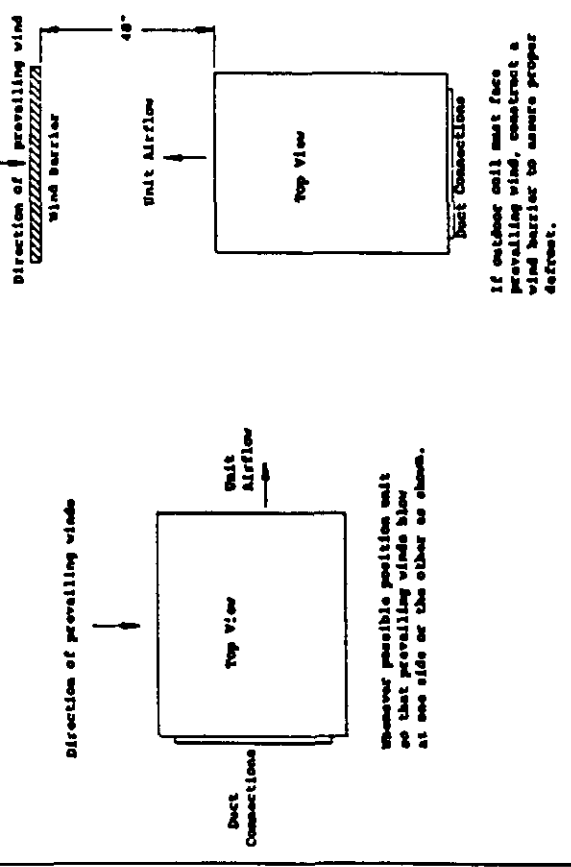

Figure 6
AIRFLOW AND SERVICE ACCESS CLEARANCE

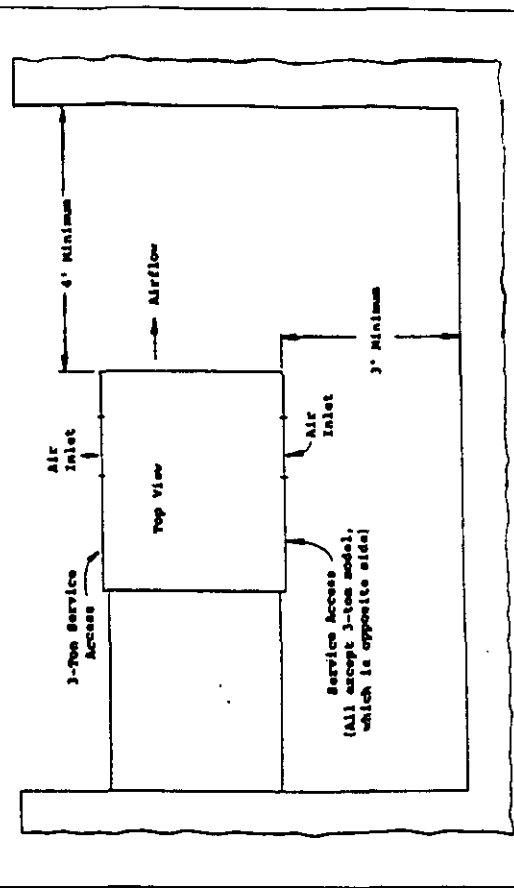
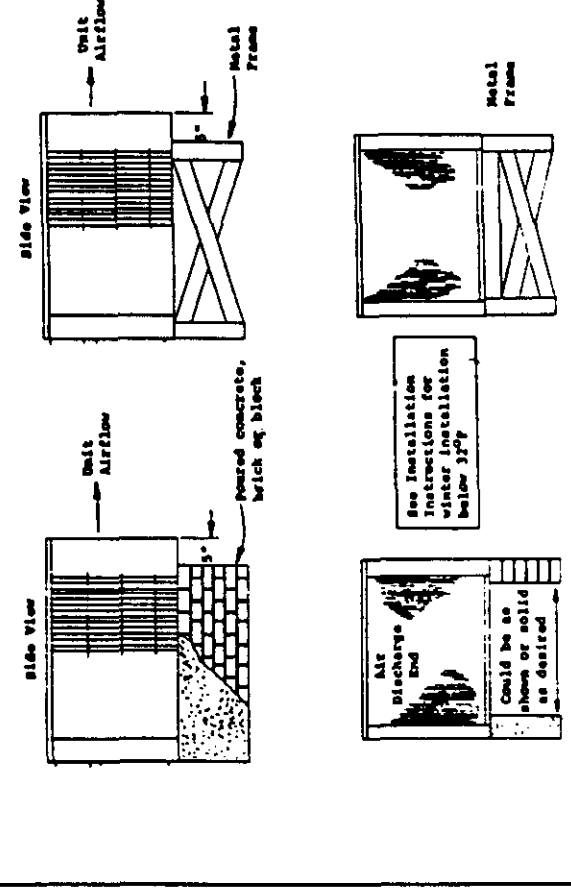

Figure 4
ELEVATED MOUNTING PLATFORMS



TYPICAL INSTALLATIONS

1. **ROOF MOUNTED**--The unit is mounted on a sturdy base on the roof of the building. Return air to the unit is brought through a single return grille (grilles with built-in filters are best, since they enable easy access for filter changing). Return air ducts are attached to the lower section of the front panel. Supply air is brought from the unit to attic duct work or to a furred down hall. Supply air duct is attached to the top of the front panel. CAUTION: All outdoor duct work must be thoroughly insulated and weatherproofed. All attic duct work must be thoroughly insulated. Two inch thick insulation with suitable vapor barrier is recommended for both outdoor and attic runs. In rooftop installations, as in all installations, the heat pump must be level from side to side. However, the unit should have a pitch along the length to assure complete external drainage of precipitation and of defrost condensate.
2. **CRAWL SPACE**--Duct work installed in crawl space must be well insulated and provided with a vapor barrier. In addition, the crawl space must be thoroughly ventilated and provided with a good vapor barrier as a ground cover. It is most desirable to install the unit outdoors, rather than inside the crawl space, so that it will be readily accessible for service. In addition, it is necessary to dispose of the condensate from the outdoor coil on the heating cycle, and this is virtually impossible with the unit installed inside the crawl space.
3. **SLAB MOUNTED AT GROUND LEVEL**--This type installation is ideal for homes with a slab floor construction, where a roof mounted unit is not desired. The supply and return duct work can be run through a furred closet space.
4. **THRU-THE-WALL**--This type installation requires a suitable framework to be fabricated capable of withstanding the unit weight. Normally the unit will be insulated so as to minimize supply and return duct work.
5. **OTHER INSTALLATIONS**--Many other installations are possible with the packaged heat pump. No matter what the installation, always consider the following facts:
 - A. Insure that the discharge air is not obstructed in any way so as to cause operation difficulties.
 - B. The indoor coil drain pan is equipped with a coupling that must be piped through a condensate drain trap to a suitable drain.
 - C. Always mount the unit in such a position that it may be easily reached for servicing and maintenance.
 - D. Insure that the unit is clear so that proper air flow over the outdoor coil will be maintained.

If this unit is operated in cooling below a 65° outdoor ambient temperature, the installation of low ambient controls (CMB-7) to unit is required.

CONDENSATE DRAIN TRAP

It is very important to provide a trap in the condensate drain line to allow a positive liquid seal in the line and assure correct drainage from the coil condensate pan.

Install condensate drain trap shown below. Use drain connection size or larger. Do not operate unit without trap. Unit must be level or slightly inclined toward drain. With a trap installed on a unit located in an unconditioned area, water in the trap may freeze. It is recommended that the trap material be of a type that will allow for expansion of water when it freezes.

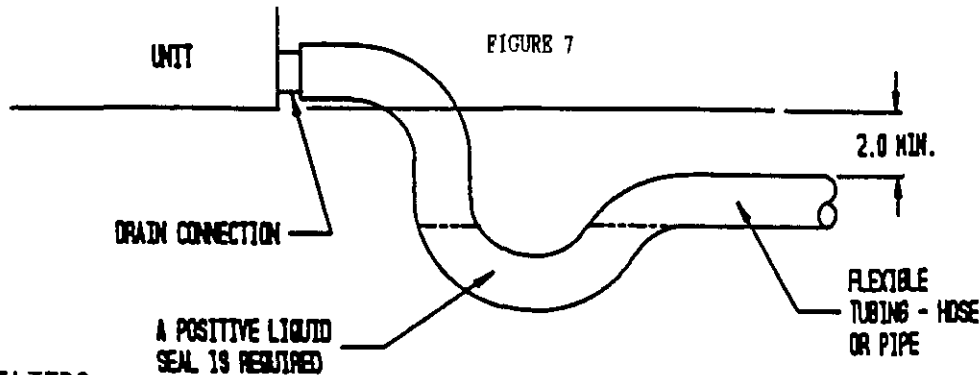

AIR FILTERS

Air filters for the return air side of the system are not provided as part of the various types of applications for these models, and must be field supplied and installed as part of the final installation.

Prior thought should be given to return air location and placement of the air filter(s). The air filter(s) must be of adequate size and readily accessible to the operator of the equipment. Filters must be adequate in size and properly maintained for proper operation. If this is not done, excessive energy use, poor performance, and multiple service problems will result. IT IS IMPOSSIBLE TO OVERSIZE AIR FILTERS. Generous sizing will result in cleaner air and coils, as well as lower operating costs and extend the time between required changes. The following table shows minimum filter areas and recommended filter sizes. Actual filter sizes can vary with the installation due to single or multiple returns utilizing a filter/grille arrangement or being placed immediately ahead of the indoor coil face in the return air duct.

TABLE 6

Model	Minimum Filter Areas	Recommended Size
PH11421, PH1048, PH1060	608 sq.in.(4.62 sq.ft.)	(2) 16 x 20 x 1

NOTE: If roof hood accessory is to be used, information on air filters may be found under that heading in this manual. Air filters are supplied as part of that package.

WIRING--MAIN POWER

Refer to the unit rating plate for wire sizing information and maximum fuse size. Each outdoor unit is marked with a "Minimum Circuit Ampacity". This means that the field wiring used must be sized to carry that amount of current. If field installed heaters are added to the basic unit, a second, separate power supply circuit will be required. The heater rating plate located adjacent to the basic unit rating plate will show the appropriate circuit ampacity, fuse size, etc. (Also see "Electrical Data" on pages 1 and 2). All models are suitable only for connection with copper wire only. These instructions MUST BE adhered to. Refer to the National Electrical Code for complete current carrying capacity data on the various insulation grades of wiring material.

The electrical specifications on pages 1 and 2 lists fuse and wire sizes (75°F copper) for all models, including the most commonly used heater sizes.

The unit rating plate lists a "Maximum Time Delay Fuse" or "RACR" type circuit breaker that is to be used with the equipment. The correct size must be used for proper circuit protection and also to assure that there will be no nuisance tripping due to the momentary high starting current of the compressor.

WIRING--24V LOW VOLTAGE CONTROL CIRCUIT

Ten (10) wires should be run from thermostat subbase to the 24V terminal board in the unit. A nine conductor, 18 gauge copper, color-coded thermostat cable is recommended. The connection points are shown on most of the wiring diagrams and are also shown below.

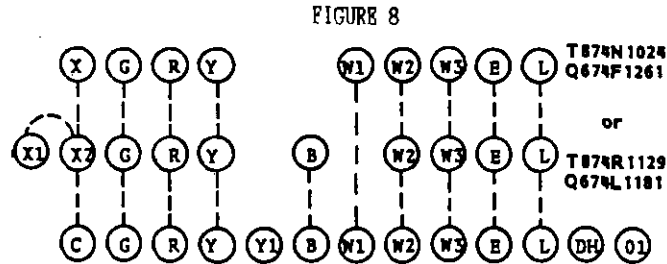

TABLE 7 THERMOSTAT WIRE SIZE

Transformer VA	FLA	Wire Gauge	Maximum Distance In Feet
55	2.3	20	45
		18	60
		16	100
		14	160
		12	250

IMPORTANT NOTE: Only the thermostat and subbase combinations as shown above will work with this equipment. The thermostat and subbase **MUST** be matched, and correct operation can be assured only by proper selection and application of these parts.

THERMOSTATS

See specific wiring information for the different models, heater KW's, and voltages on pages 12 and 13.

TABLE 8

WALL THERMOSTAT AND SUBBASE COMBINATIONS			
Group	Thermostat	Subbase	Predominant Feature
A	8403-017	8404-009	Heat or Cool (1)
	(T874R1129)	(Q674L1181)	No Auto
B	8403-018	8404-010	Automatic Heat-Cool (2)
	(T874N1024)	(Q674F1261)	Changeover Position

- (1) No automatic changeover position--must manually place in heat or cool. Reversing valve remains energized at all times system switch is in heat position (except during defrost cycle). No pressure equalization noise when thermostat is satisfied on either heating or cooling.
- (2) Allows thermostat to control both heating and cooling operation when set in "AUTO" position. Reversing valve deenergizes at end of each "ON" heating cycle.

IMPORTANT NOTE: Both thermostat and subbase combinations shown above incorporate the following features: Man-Auto fan switch, Off-Heat-Cool-Em. Heat Switch, and two (2) indicator lamps--one for emergency heat and one for compressor malfunction.

THERMOSTAT INDICATOR LAMPS

The red lamp marked "EM. HT." comes on and stays on whenever the system switch is placed in EM. HT. position. The green lamp marked "check" will come on if there is any problem that prevents the compressor from running when it is supposed to be.

EMERGENCY HEAT POSITION

The operator of the equipment must manually place the system switch in this position. This is done when there is a known problem with the outdoor section, or when the green "check" lamp comes on indicating a problem.

TRANSFORMER TAPS

230/208V, 1 phase and 3 phase equipment employ dual primary voltage transformers. All equipment leaves the factory wired on 240V tap. For 208V operation, reconnect from 240V to 208V tap. The acceptable operating voltage range for the 240 and 208V taps are:

<u>TAP</u>	<u>RANGE</u>
240	253 - 216
208	220 - 187

NOTE: The voltage should be measured at the field power connection point in the unit and while the unit is operating at full load (maximum amperage operating condition).

COMPRESSOR CUT-OFF THERMOSTAT AND OUTDOOR THERMOSTAT WIRING

Heat pump compressor operation at outdoor temperatures below 0°F are neither desirable nor advantageous in terms of efficiency. Since most equipment at time of manufacture is not designated for any specific destination of the country, and most of the equipment is installed in areas not approaching the lower outdoor temperature range, the compressor cut-offs are not factory installed.

Outdoor thermostats are available to hold off various banks of electric heat until needed as determined by outdoor temperature. The set point of either type of thermostat is variable with geographic region and sizing of the heating equipment to the structure. Utilization of the Heating Application Data and the heat loss calculation of the building are useful in determining the correct set points.

COMPRESSOR CUT-OFF WIRING

FIGURE 9
Unit 24V Terminal Board

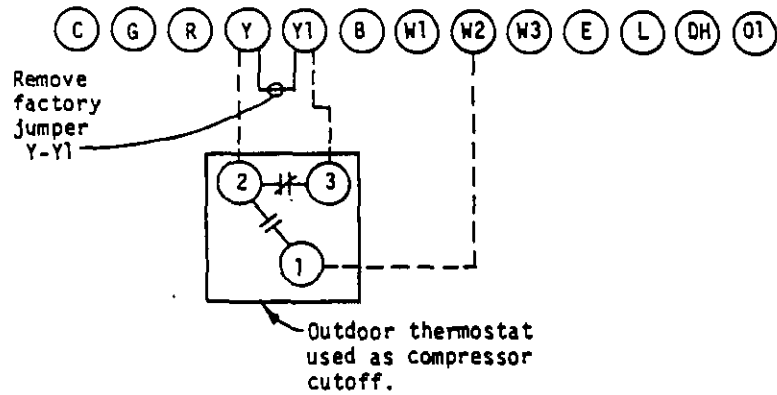

TABLE 9

Model	KW	Volts	Phase
PH11421	0, 5, 10	230	1
PH1048	0, 5, 10	230	1
PH1048-B,-C	0, 9	230, 460	3
PH1060	0, 5, 10	230	1
PH1060-B,-C	0, 9	230, 460	3

COMPRESSOR CUT-OFF AND OUTDOOR THERMOSTAT WIRING.

FIGURE 10
Unit 24V Terminal Board

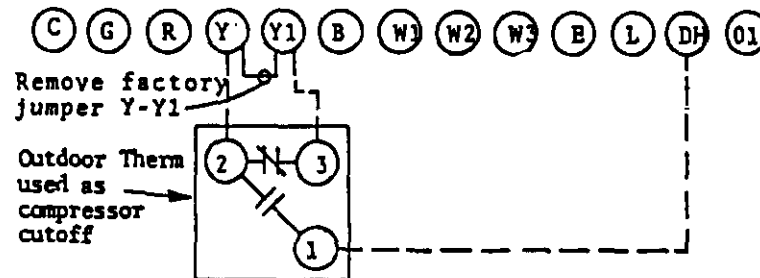

TABLE 10

Model	KW	Volts	Phase
PH11421	15, 20	230	1
PH1048	15, 20	230	1
PH1048-B,-C	15, 18	230, 460	3
PH1060	15, 20	230	1
PH1060-B,-C	15, 18	230, 460	3

START UP AND OPERATION

THREE PHASE SCROLL COMPRESSOR START UP INFORMATION

Scroll compressors, like several other types of compressors, will only compress in one rotational direction. Direction of rotation is not an issue with single phase compressors since they will always start and run in the proper direction.

However, three phase compressors will rotate in either direction depending upon phasing of the power. Since there is a 50-50 chance of connecting power in such a way as to cause rotation in the reverse direction, verification of proper rotation must be made. Verification of proper rotation direction is made by observing that suction pressure drops and discharge pressure rises when the compressor is energized. Reverse rotation also results in an elevated sound level over that with correct rotation, as well as, substantially reduced current draw compared to tabulated values.

There is no negative impact on durability caused by operating three phase Compliant Scroll compressors in the reversed direction. However, after several minutes of operation, the compressor's internal protection will trip.

All three phase ZR*3 compressors are wired identically internally. As a result, once the correct phasing is determined for a specific system or installation, connecting properly phased power leads to the same Fusite terminals should maintain proper rotation direction.

THE DIRECTION OF ROTATION OF THE MOTOR MAY BE CHANGED BY REVERSING ANY TWO LINE CONNECTIONS TO THE UNIT.

SEQUENCE OF OPERATION

COOLING--Circuit R-Y makes at thermostat pulling in compressor contactor starting the compressor and outdoor motor. The G (indoor motor) circuit is automatically completed on any call for cooling operation, or can be energized by manual fan switch on subbase for constant air circulation.

HEATING--A 24V solenoid coil on reversing valve controls heating cycle operation. Two thermostat options, one allowing "AUTO" changeover from cycle to cycle and the other constantly energizing solenoid coil during heating season and thus eliminating pressure equalization noise except during defrost, are to be used. On "AUTO" option, a circuit is completed from R-W1 and R-Y on each heating "on" cycle, energizing reversing valve solenoid and pulling in compressor contactor starting compressor and outdoor motor. R-G also make starting indoor blower motor. Heat pump heating cycle now in operation. The second energizes the reversing valve solenoid constantly whenever the system switch on subbase is placed in "Heat" position, the "B" terminal being constantly energized from R. A thermostat demand for heat completes R-Y circuit, pulling in compressor contactor starting compressor and outdoor motor. R-G also make starting indoor blower motor.

DEFROST CYCLE

The defrost cycle is controlled by temperature and time on the solid state heat pump control.

When the outdoor temperature is in the lower 40°F temperature range or colder, the outdoor coil temperature is 32°F or below. This temperature is sensed by the coil sensor mounted near the bottom of the outdoor coil. Once the coil temperature reaches 32°F or below, the coil sensor sends a signal to the control logic of the heat pump control and defrost timer will start.

After 60 (90 or 30 minutes) minutes at 32°F or below, the heat pump control will place the system in the defrost mode.

During the defrost mode, the refrigerant cycle switches back to the cooling cycle, the outdoor motor stops, electric heaters are energized, and hot gas passing through the outdoor coil melts any accumulated frost. When the temperature rises to approximately 57°F, the coil sensor will send a signal to the heat pump control which will return the system to heating operations automatically.

If some abnormal or temporary condition such as a high wind causes the heat pump to have a prolonged defrost cycle, the heat pump control will restore the system to heating operation automatically after 10 minutes.

There are three settings on the heat pump control--30 minute, 60 minute, and 90 minute. Most models are shipped wired on the 60 minute setting for greatest operating economy. If special circumstances require a change to another time, remove wire connected to terminal 60 and reconnect to desired terminal.

There is a cycle speed up jumper on the control. This can be used to reduce the time between defrost cycle operation without waiting for time to elapse.

There is an initial defrost (sen jmp) jumper on the control that can be used at any outdoor ambient during the heating cycle to simulate a 0° coil temperature. This can be used to check defrost operation of the unit without waiting for the outdoor ambient to fall into the defrost region.

FIGURE 11

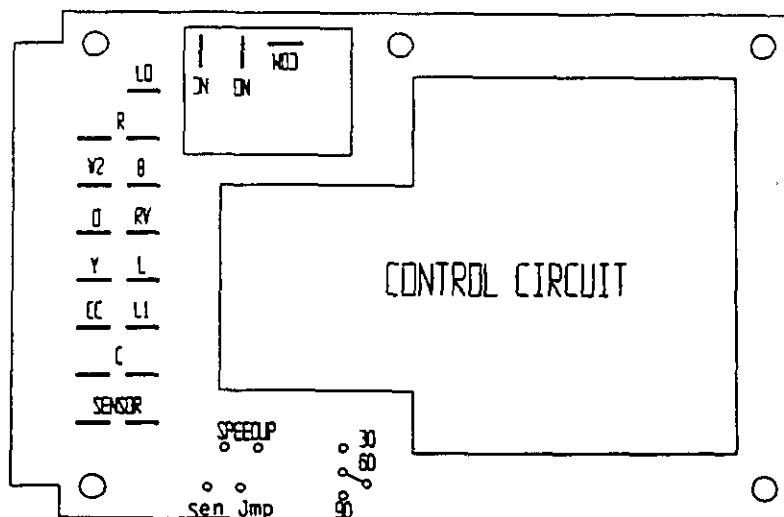

START UP NOTES

For improved start-up performance, wash the indoor coil with a dishwasher detergent.

SERVICE AND TROUBLESHOOTING

SERVICE HINTS

1. Caution homeowner to maintain clean air filters at all times. Also, not to needlessly close off supply and return air registers. This reduces air flow through the system which shortens equipment service life as well as increasing operating costs.
2. Switching to heating cycle at 75°F or higher outside temperature may cause a nuisance trip of the manual reset high pressure switch.
3. The heat pump wall thermostats perform multiple functions. Be sure that all function switches are correctly set for the desired operating mode before trying to diagnose any reported service problems.

4. Check all power fuses or circuit breakers to be sure that they are the correct rating.
5. Periodic cleaning of the outdoor coil to permit full and unrestricted airflow circulation is essential.

PRESSURE SERVICE PORTS

High and low pressure service ports are installed on all units so that the system operating pressures can be observed. Pressure tables can be found later in the manual covering all models on both cooling and heating cycles. It is imperative to match the correct pressure table to the unit by model number.

REFRIGERANT CHARGE

The correct system R-22 charge is shown on the unit rating plate. Optimum unit performance will occur with a refrigerant charge resulting in a suction line temperature (6" from compressor) as shown in the following table:

TABLE 11

Model	Rated Airflow	95° OD Temperature	82° OD Temperature
PH11421	1400	54 - 56	57 - 59
PH1048	1550	54 - 56	59 - 61
PH1060	1700	52 - 54	57 - 59

The above suction line temperatures are based upon 80°F dry bulb/67°F wet bulb (50 percent RH) temperature and rated airflow across the evaporator during cooling cycle.

FAN BLADE SETTINGS

Shown in the drawing below are the correct fan blade setting dimensions for proper air delivery across the outdoor coil.

Any service work requiring removal or adjustment in the fan and/or motor area will require that the dimensions below be checked and blade adjusted in or out on the motor shaft accordingly.

FIGURE 12

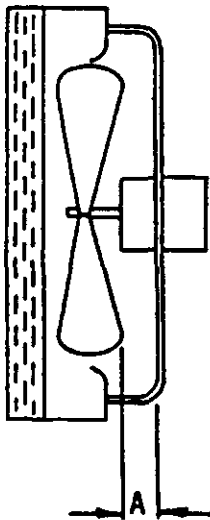

Model	Dimension A
PH11421	1.75"
PH1048	1.75"
PH1060	1.75"

SOLID STATE HEAT PUMP CONTROL TROUBLESHOOTING PROCEDURE

1. Turn on AC power supply to indoor and outdoor units.
2. Turn thermostat blower switch to fan on--the indoor blower should start. (If it doesn't, troubleshoot indoor unit and correct problem).
3. Turn thermostat blower switch to auto position. Indoor blower should stop.
4. Set system switch to heat or cool. Adjust thermostat to call for heat or cool--The indoor blower, compressor, and outdoor fan should start.

NOTE: If there was no power to 24 volt transformer, the compressor and outdoor fan motor will not start for 5 minutes. This is because of the compressor short cycle protection.

TROUBLESHOOTING

Symptom	Possible Causes	What to Check	How To Check Or Repair
Compressor contactor does not energize (cooling or heating)	Control circuit wiring	Check for R connection at unit, and 24V between R-C.	Run R connection to outdoor unit to power heat pump control.
	Compressor lock out	1. Check for 24V between Li-C on heat pump control. 2. Check across high pressure switch.	1. If no voltage between Li-C turn thermostat off and on again to reset high pressure switch. 2. If high pressure switch is open and will not reset, replace high pressure switch.
	Compressor short cycle protection	Check for 24V between CC-C and Y-C on heat pump control.	1. If no voltage between CC-C jumper speed up terminal and within 10 seconds power should appear between CC-C. Remove speed up jumper after 10 seconds.
	Heat pump control defective	Check all other possible causes. Manual 2100-065	Replace heat pump control.
	Contactor defective	Check for open or shorted coil winding.	Replace contactor.
Fan outdoor motor does not run (cooling or heating except during defrost)	Motor defective	Check for open or shorted motor winding	Replace motor.
	Motor capacitor defective	Check capacitor rating. Check for open or shorted capacitor.	Replace capacitor.
	Heat pump control defective	Check across fan relay on heat pump control. (Com-NC)	Replace heat pump control.
Reversing valve does not energize (heating only)	Reversing valve solenoid coil defective	Check for open or shorted coil.	Replace solenoid coil.
	Heat pump control defective	Check for 24V between RV-C and B-C.	1. Check control circuit wiring. 2. Replace heat pump control.
Unit will not go into defrost (heating only)	Temperature sensor or heat pump control defective	Disconnect temperature sensor from board and jumper across speed up terminals and sen jmp terminals. This should cause the unit to go through a defrost cycle within one minute.	1. If unit goes through defrost cycle, replace temperature sensor. 2. If unit does not go through defrost cycle, replace heat pump control.
Unit will not come out of defrost (heating only)	Temperature sensor or heat pump control defective	Jumper across speed up terminals. This should cause the unit to come out of defrost within one minute.	1. If unit comes out of defrost cycle, replace temperature sensor. 2. If unit does not come out of defrost cycle, replace heat pump control.

CHECKING TEMPERATURE SENSOR CHECKOUT

1. Disconnect temperature sensor from board and from outdoor coil.
2. Use an ohmmeter and measure the resistance of the sensor. Also use ohmmeter to check for short or open.
3. Check resistance reading to chart of resistance use sensor ambient temperature. (Tolerance of part is $\pm 10\%$).
4. If sensor resistance reads very low, then sensor is shorted and will not allow proper operation of the heat pump control.
5. If sensor is out of tolerance, shorted, open, or reads very low ohms then it should be replaced.

TEMPERATURE F VS RESISTANCE R OF TEMPERATURE SENSOR

F	R	F	R	F	R
-25.0	196871	25.0	39898	75.0	10501
-24.0	190099	26.0	38757	76.0	10247
-23.0	183585	27.0	37652	77.0	10000
-22.0	177318	28.0	36583	78.0	9760
-21.0	171289	29.0	35548	79.0	9526
-20.0	165487	30.0	34545	80.0	9299
-19.0	159904	31.0	33574	81.0	9077
-18.0	154529	32.0	32634	82.0	8862
-17.0	149355	33.0	31723	83.0	8653
-16.0	144374	34.0	30840	84.0	8449
-15.0	139576	35.0	29986	85.0	8250
-14.0	134956	36.0	29157	86.0	8057
-13.0	130506	37.0	28355	87.0	7869
-12.0	126219	38.0	27577	88.0	7686
-11.0	122089	39.0	26823	89.0	7507
-10.0	118108	40.0	26092	90.0	7334
-9.0	114272	41.0	25383	91.0	7165
-8.0	110575	42.0	24696	92.0	7000
-7.0	107010	43.0	24030	93.0	6840
-6.0	103574	44.0	23384	94.0	6683
-5.0	100260	45.0	22758	95.0	6531
-4.0	97064	46.0	22150	96.0	6383
-3.0	93981	47.0	21561	97.0	6239
-2.0	91008	48.0	20989	98.0	6098
-1.0	88139	49.0	20435	99.0	5961
0.0	85371	50.0	19896	100.0	5827
1.0	82699	51.0	19374	101.0	5697
2.0	80121	52.0	18867	102.0	5570
3.0	77632	53.0	18375	103.0	5446
4.0	75230	54.0	17898	104.0	5326
5.0	72910	55.0	17434	105.0	5208
6.0	70670	56.0	16984	106.0	5094
7.0	68507	57.0	16547	107.0	4982
8.0	66418	58.0	16122	108.0	4873
9.0	64399	59.0	15710	109.0	4767
10.0	62449	60.0	15310	110.0	4663
11.0	60565	61.0	14921	111.0	4562
12.0	58745	62.0	14544	112.0	4464
13.0	56985	63.0	14177	113.0	4367
14.0	55284	64.0	13820	114.0	4274
15.0	53640	65.0	13474	115.0	4182
16.0	52051	66.0	13137	116.0	4093
17.0	50514	67.0	12810	117.0	4006
18.0	49028	68.0	12492	118.0	3921
19.0	47590	69.0	12183	119.0	3838
20.0	46200	70.0	11883	120.0	3757
21.0	44855	71.0	11591	121.0	3678
22.0	43554	72.0	11307	122.0	3601
23.0	42295	73.0	11031	123.0	3526
24.0	41077	74.0	10762	124.0	3452

SUCTION AND DISCHARGE TUBE BRAZING

Compliant Scroll Compressors have copper plated steel suction and discharge tubes. These tubes are far more rugged and less prone to leaks than copper tubes used on other compressors. Due to a different thermal properties of steel and copper, brazing procedures may have to be changed from those commonly used.

- To disconnect: heat joint Areas 2 and 3 Slowly and uniformly until braze material softens and tube can be pulled out of suction fitting.
- To reconnect.
 - Recommended brazing materials: silfos with minimum 5% silver or silver braze material with flux.
 - Reinsert tube into fitting.
 - Heat tube uniformly in Area 1, moving slowly to Area 2. When joint reaches brazing temperature, apply brazing material.
 - Heat joint uniformly around the circumference to flow braze material completely around the joint.
 - Slowly move torch into Area 3 to draw braze material into joint.
 - Do no overheat joint.

FIGURE 13

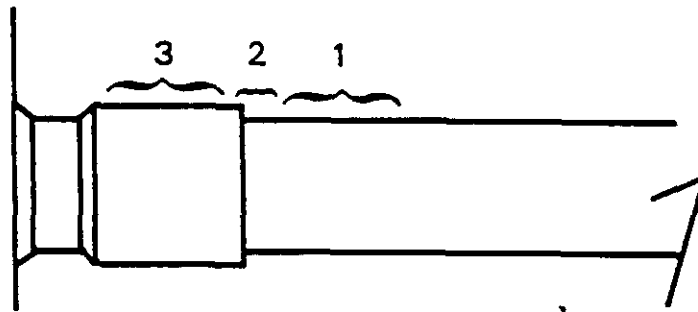

DISCHARGE (TOP CAP) THERMOSTAT (PH11421 ONLY)

All P11 series models feature scroll compressors. Since the scroll is a new type of compressor, there are a number of application characteristics that are different than the traditional reciprocating compressor.

Internal discharge temperatures reached under some extreme operating conditions (such as loss of charge or extremely high compression ratio caused by failure of evaporator fan) can cause compressor damage. In order to guarantee positive compressor protection, a thermostat has been designed into the Compliant Scroll which senses dangerous discharge temperature levels and removes power from the compressor until temperature levels are safe again. The approximate thermostat cut-out/cut-in temperatures are 290/140°F. THIS PROTECTIVE DEVICE SHOULD NEVER BE BYPASSED FOR ANY PURPOSE.

The thermostat can be tested for proper operation by the following procedures:

To check for low temperature, check electrical continuity with the thermostat below 140°F. If the thermostat shows open, it should be replaced.

To check for high temperature protection, the thermostat should remain closed for increasing discharge line temperatures up to 290°F, and then open as temperature rises above 290°F. If the thermostat is open when temperature is between 140 and 290°F, the thermostat will have to be allowed to cool to 140°F to close before testing high temperature operation. If the thermostat opens below 290°F with rising temperature, it should be replaced.

The thermostat can be replaced by following these steps. Carefully pry the plastic cover open with a screwdriver. The thermostat is held to the bottom of the well with adhesive. Pry the thermostat from the well. (See Figure 14) The replacement thermostat does not require adhesive but must be held down with the neoprene spacer provided with the cover. The new cover is held down by snapping the prongs into the rim of the thermostat well after a silicone sealant provided to reseal the cover is applied to the rims of the well cover. The sensor terminals are located outside the compressor terminal box. Figure 15 shows the arrangement of compressor line voltage terminals and discharge sensor terminals.

Because of its very high volumetric efficiency, a Compliant Scroll Compressor will draw extremely low vacuums when the suction side of the compressor is closed or severely restricted. These vacuums, if achieved, can cause internal Fusite arcing resulting in a damaged or failed compressor. Damage resulting from internal Fusite arcing due to low pressure is obvious at compressor teardown and will result in denial of warranty claims.

In addition to possibly damaging the Fusite, the internal arcing caused by operation of Compliant Scroll compressors at deep vacuum conditions may cause tripping of circuit breakers, blowing of fuses, or tripping of the external compressor thermostat.

FIGURE 14

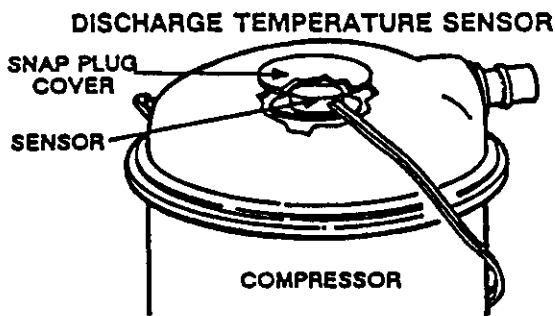

FIGURE 15

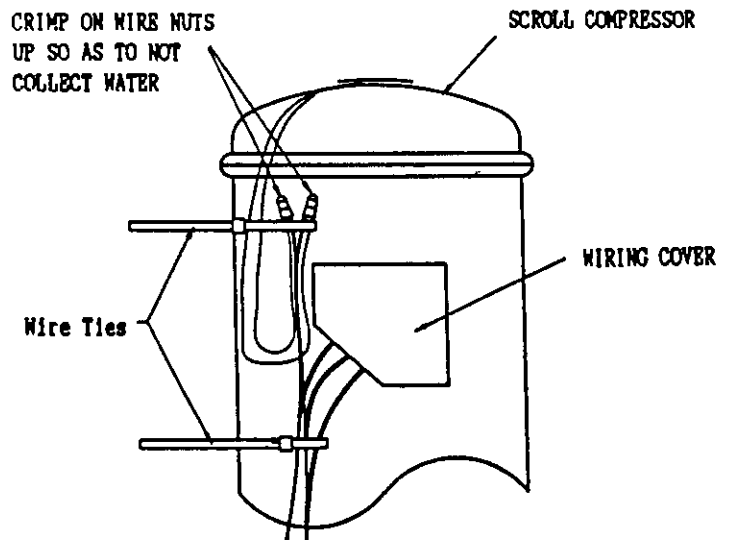

TABLE 12

COOLING

			Air Temperature Entering Outdoor Coil °F								
Model	Return Air Temperature	Pressure	°	°	°	°	°	°	°	°	°
			75	80	85	90	95	100	105	110	115
PH1142	75 deg. DB	Low Side	74	75	77	78	79	80	81	82	83
	62 deg. WB	High Side	192	210	227	244	261	279	296	314	332
	80 deg. DB	Low Side	79	80	82	83	84	85	87	88	89
	67 deg. WB	High Side	197	215	233	250	268	286	304	322	340
	72 deg. WB	High Side	204	223	241	259	277	296	315	333	352
PH1048	75 deg. DB	Low Side	71	73	75	76	77	78	79	80	81
	62 deg. WB	High Side	211	226	243	258	276	293	310	329	347
	80 deg. DB	Low Side	76	78	80	81	83	84	85	86	87
	67 deg. WB	High Side	216	232	249	265	283	300	318	337	356
	72 deg. WB	High Side	224	240	258	274	292	311	329	349	368
PH1060	75 deg. DB	Low Side	65	66	68	69	70	71	72	73	74
	62 deg. WB	High Side	199	216	235	254	272	291	309	328	345
	80 deg. DB	Low Side	70	71	72	73	75	76	77	78	79
	67 deg. WB	High Side	204	222	241	260	279	298	317	336	354
	72 deg. WB	High Side	211	230	249	269	289	308	328	348	366

TABLE 13

HEATING

			Air Temperature Entering Outdoor Coil °F														
Model	Return Air Temperature	Pressure	0	5	10	15	17	20	25	30	35	40	45	47	50	55	60
			PH1421	70°	Low Side	17	19	21	26	29	33	38	45	49	52	55	56
High Side	156	161			165	169	171	173	177	181	186	193	199	203	207	214	221
PH1048	70°	Low Side	25	27	29	31	32	34	36	38	40	47	54	56	60	67	73
		High Side	160	164	168	172	174	176	180	184	188	194	201	204	208	214	221
PH1060	70°	Low Side	17	19	21	24	26	29	33	37	41	46	50	52	55	59	64
		High Side	156	164	172	180	183	187	195	203	211	219	226	230	234	243	250

Low side pressure \pm 2 PSIGHigh side pressure \pm 5 PSIG

Tables are based upon rated CFM (airflow) across the evaporator coil and should be found under section titled "Refrigerant Charge" elsewhere in manual. If there is any doubt as to correct operating charge being in the system, the charge should be removed, system evacuated, and recharged to serial plate instructions.

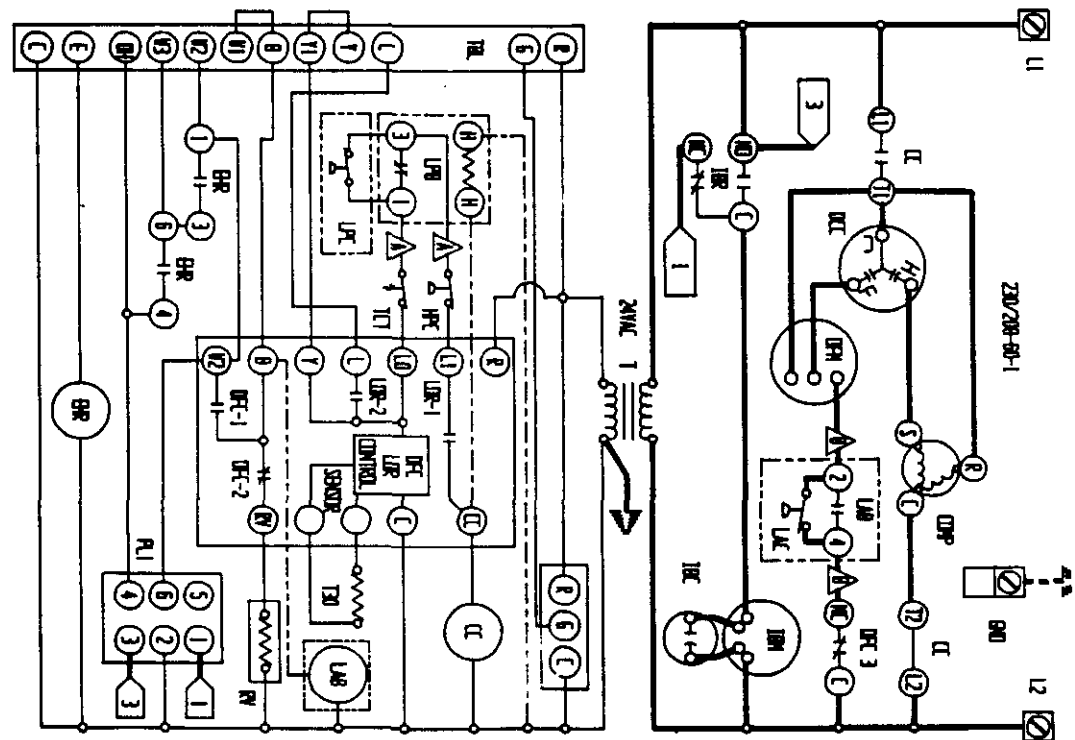
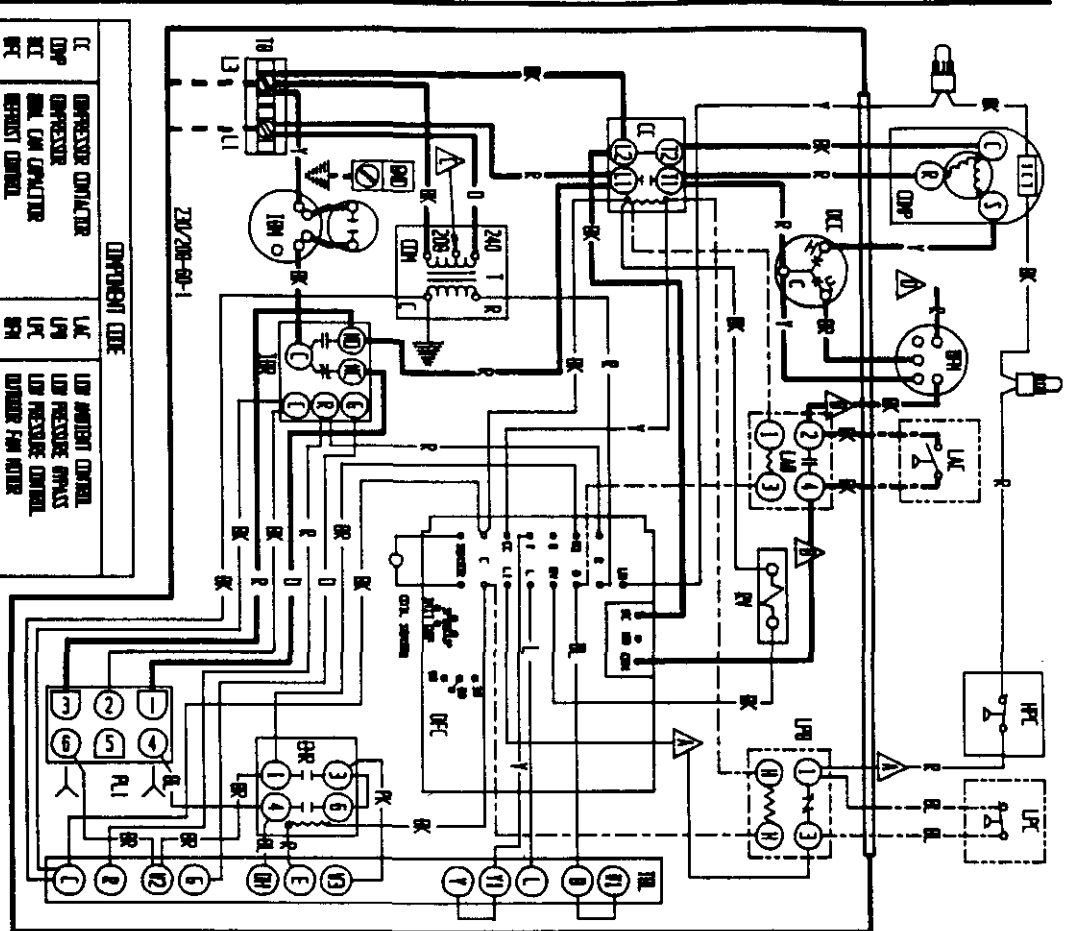

COMPONENT CODE

UC	DIFFERENTIAL CONTACTOR	UC	UP MOTOR CONTROL
OMP	DIFFERENTIAL CONTACTOR	UP	UP PRESSURE SWITCH
RI	RELAY	UR	UP PRESSURE CONTROL
RC	RELAY	UR	UP PRESSURE CONTROL
RD	RELAY	UR	UP PRESSURE CONTROL
RE	RELAY	UR	UP PRESSURE CONTROL
RF	RELAY	UR	UP PRESSURE CONTROL
RG	RELAY	UR	UP PRESSURE CONTROL
RH	RELAY	UR	UP PRESSURE CONTROL
RI	RELAY	UR	UP PRESSURE CONTROL
RJ	RELAY	UR	UP PRESSURE CONTROL
RK	RELAY	UR	UP PRESSURE CONTROL
RL	RELAY	UR	UP PRESSURE CONTROL
RM	RELAY	UR	UP PRESSURE CONTROL
RN	RELAY	UR	UP PRESSURE CONTROL
RO	RELAY	UR	UP PRESSURE CONTROL
RP	RELAY	UR	UP PRESSURE CONTROL
RQ	RELAY	UR	UP PRESSURE CONTROL
RR	RELAY	UR	UP PRESSURE CONTROL
RS	RELAY	UR	UP PRESSURE CONTROL
RT	RELAY	UR	UP PRESSURE CONTROL
RU	RELAY	UR	UP PRESSURE CONTROL
RV	RELAY	UR	UP PRESSURE CONTROL
RW	RELAY	UR	UP PRESSURE CONTROL
RX	RELAY	UR	UP PRESSURE CONTROL
RY	RELAY	UR	UP PRESSURE CONTROL
RZ	RELAY	UR	UP PRESSURE CONTROL

WIRE COLOR CODE

BLACK	RED	GREEN	YELLOW	ORANGE	WHITE
BRN	BLK	GRN	YEL	ORG	WHT
BLU	GRY	TRK	PK	UNK	
BLU	GRY	TRK	PK	UNK	

WIRE COLOR CODE

BLACK	RED	GREEN	YELLOW	ORANGE	WHITE
BRN	BLK	GRN	YEL	ORG	WHT
BLU	GRY	TRK	PK	UNK	
BLU	GRY	TRK	PK	UNK	

WIRE COLOR CODE

BLACK	RED	GREEN	YELLOW	ORANGE	WHITE
BRN	BLK	GRN	YEL	ORG	WHT
BLU	GRY	TRK	PK	UNK	
BLU	GRY	TRK	PK	UNK	

240V/200-0-1

240V/200-0-1

240V/200-0-1

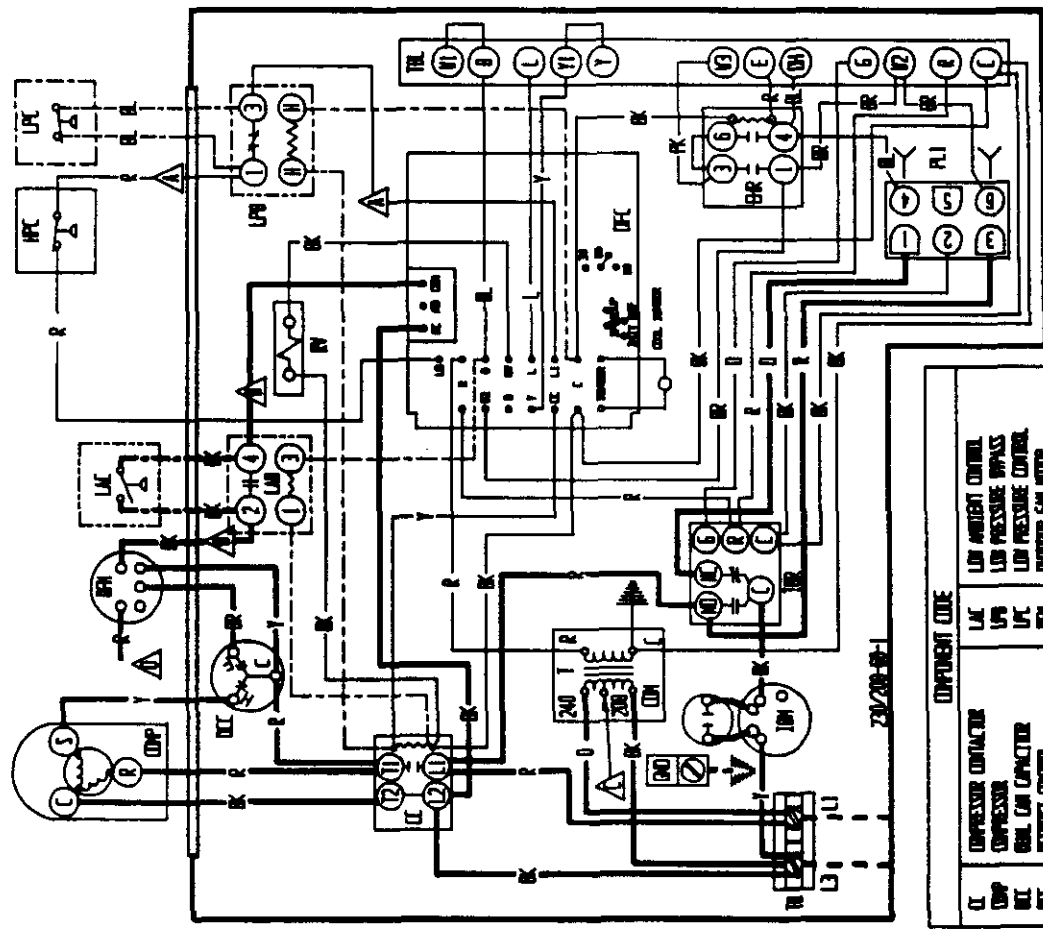
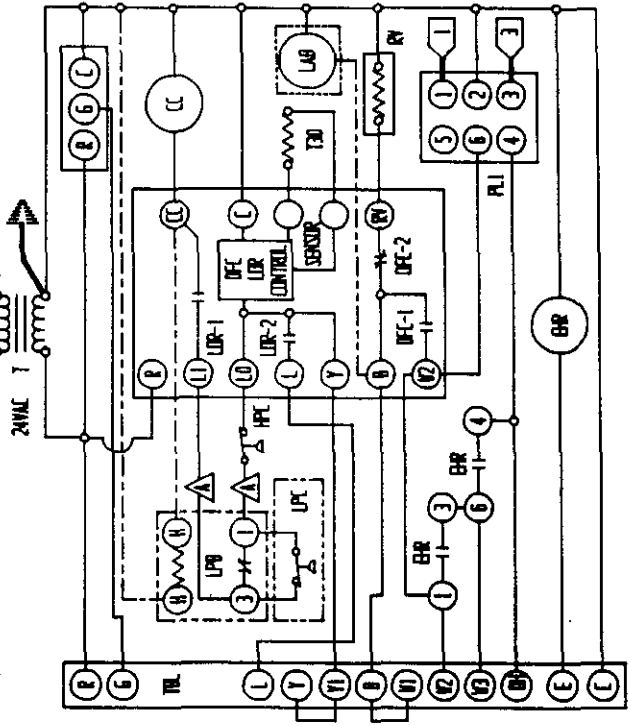
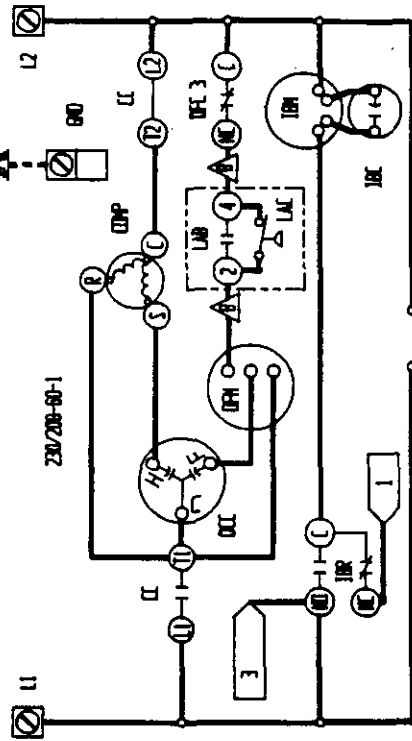

▲ ▲ LABELED WIRES CORRECT BY NO OPTIONS DESI. ▲ WIRE RED WIRE IN 208V TAP FOR 208V OPERATION ▲ RED (LOW) BLACK (HIGH) WIRE APPLICABLE

PACKING VOL.	FIELD	OPTIONAL	COLOR CODE	T	PK	L
BLACK	Y	YELLOW	V	VIOL	PK <td>L</td>	L
RED	C	GREEN	(PR)	PURPLE	PK <td>L</td>	L
BLUE	B	BLUE	BY	GRAY	PK <td>L</td>	L
WHITE	W	WHITE	(S)	SLATE	PK <td>L</td>	L

BARO INC. CO.

BAR.	488-114
BAR.	488-114
BAR.	488-114
BAR.	488-114

COMPONENT CODE	DESCRIPTION
CL	COMPRESSOR CONTACTOR
CLP	COMPRESSOR CAPACITOR
CLC	CONDENSER CAPACITOR
CLF	CONDENSER FAN MOTOR
CLG	CONDENSER FAN MOTOR RELAY
CLH	CONDENSER FAN MOTOR RELAY CAPACITOR
CLI	CONDENSER FAN MOTOR RELAY CAPACITOR
CLJ	CONDENSER FAN MOTOR RELAY CAPACITOR
CLK	CONDENSER FAN MOTOR RELAY CAPACITOR
CLL	CONDENSER FAN MOTOR RELAY CAPACITOR
CLM	CONDENSER FAN MOTOR RELAY CAPACITOR
CLN	CONDENSER FAN MOTOR RELAY CAPACITOR
CLP	CONDENSER FAN MOTOR RELAY CAPACITOR
CLQ	CONDENSER FAN MOTOR RELAY CAPACITOR
CLR	CONDENSER FAN MOTOR RELAY CAPACITOR
CLS	CONDENSER FAN MOTOR RELAY CAPACITOR
CLT	CONDENSER FAN MOTOR RELAY CAPACITOR
CLU	CONDENSER FAN MOTOR RELAY CAPACITOR
CLV	CONDENSER FAN MOTOR RELAY CAPACITOR
CLW	CONDENSER FAN MOTOR RELAY CAPACITOR
CLX	CONDENSER FAN MOTOR RELAY CAPACITOR
CLY	CONDENSER FAN MOTOR RELAY CAPACITOR
CLZ	CONDENSER FAN MOTOR RELAY CAPACITOR

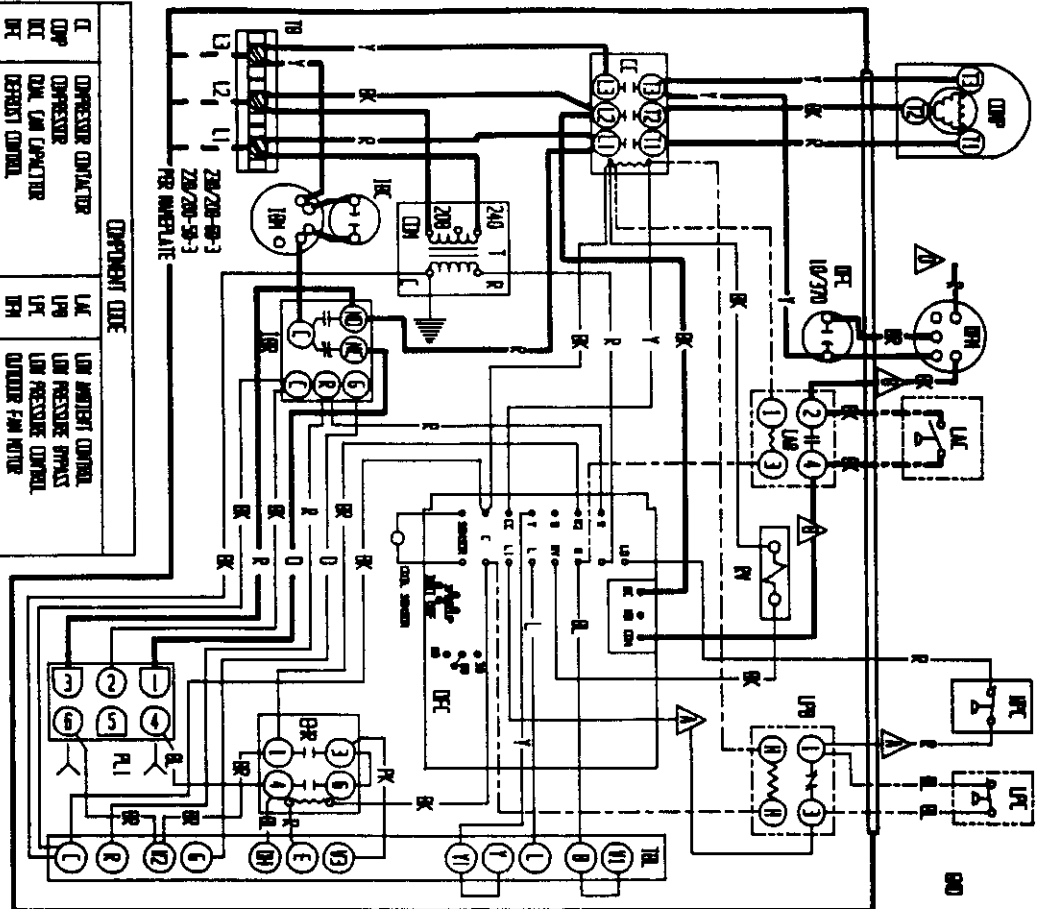

COMPONENT CODE

CT	COMPRESSOR CONTACTOR	L16	LOW AMBIENT CONTROL
DCP	COMPRESSOR	L17	LOW PRESSURE SWITCH
DC	LOW CAPACITOR	L18	LOW PRESSURE CONTROL
DFC	DEFROST CONTROL	L19	OUTDOOR FAN MOTOR
DR	DEFROST HEAT RELAY	L20	RELAY
DRD	DEFROST CONTROL	L21	SET POINT SELECTOR
HPC	HIGH PRESSURE CONTROL	L22	TEMPERATURE
IM	INDOOR BLOWER MOTOR	L23	TEMPERATURE BLOCK
IR	INDOOR BLOWER RELAY	L24	UP VOLTAGE TERMINAL BLOCK
LAG	LOW AMBIENT BYPASS CONTROL		

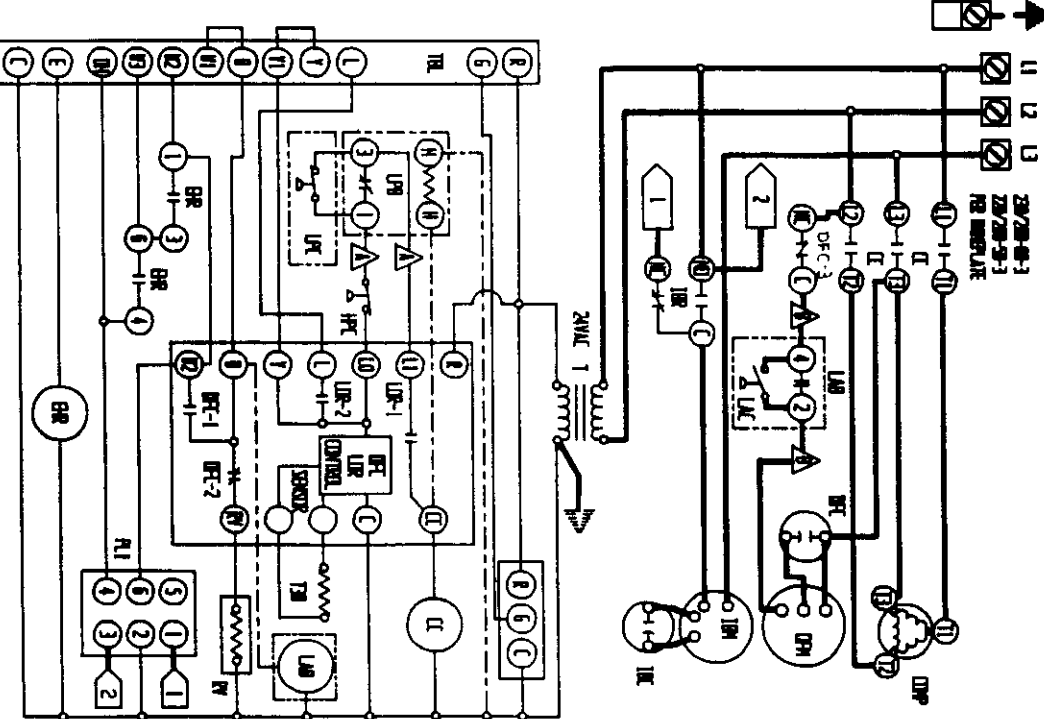

WIRE COLORS TO BE USED

FACTORY STD.	FIELD	OPTIONAL
BLACK	BLACK	BLACK
BROWN	BROWN	BROWN
RED	RED	RED
BLUE	BLUE	BLUE
GREEN	GREEN	GREEN
YELLOW	YELLOW	YELLOW
WHITE	WHITE	WHITE

WIRE CODE

Y	YELLOW	Y	YELLOW
R	RED	R	RED
B	BROWN	B	BROWN
W	WHITE	W	WHITE
GR	GREEN	GR	GREEN
BL	BLUE	BL	BLUE
OR	ORANGE	OR	ORANGE
P	PURPLE	P	PURPLE
PK	PINK	PK	PINK
SL	SLATE	SL	SLATE

WIRE COLOR CODE

DK.	4002-211 A
OR.	OR.
PK.	PK.
SL.	SL.

BAIRD MFG. CO.
4002-211 A
OR.
PK.
SL.

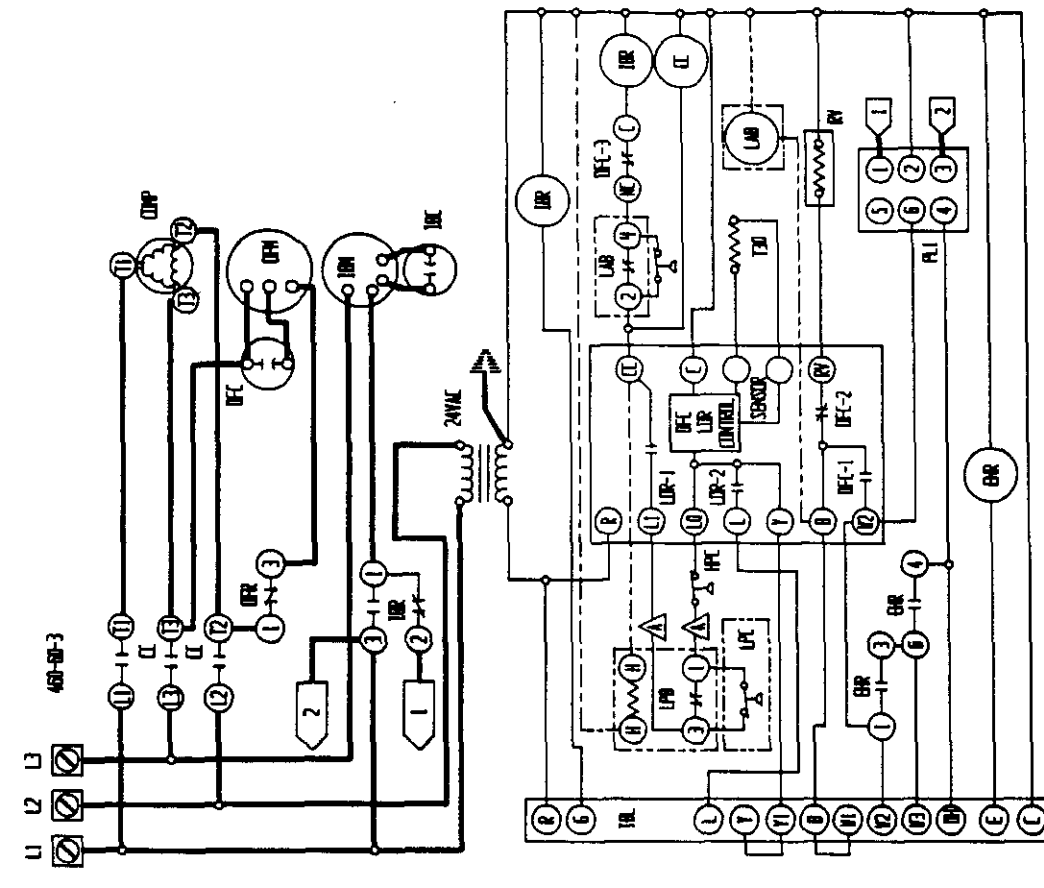
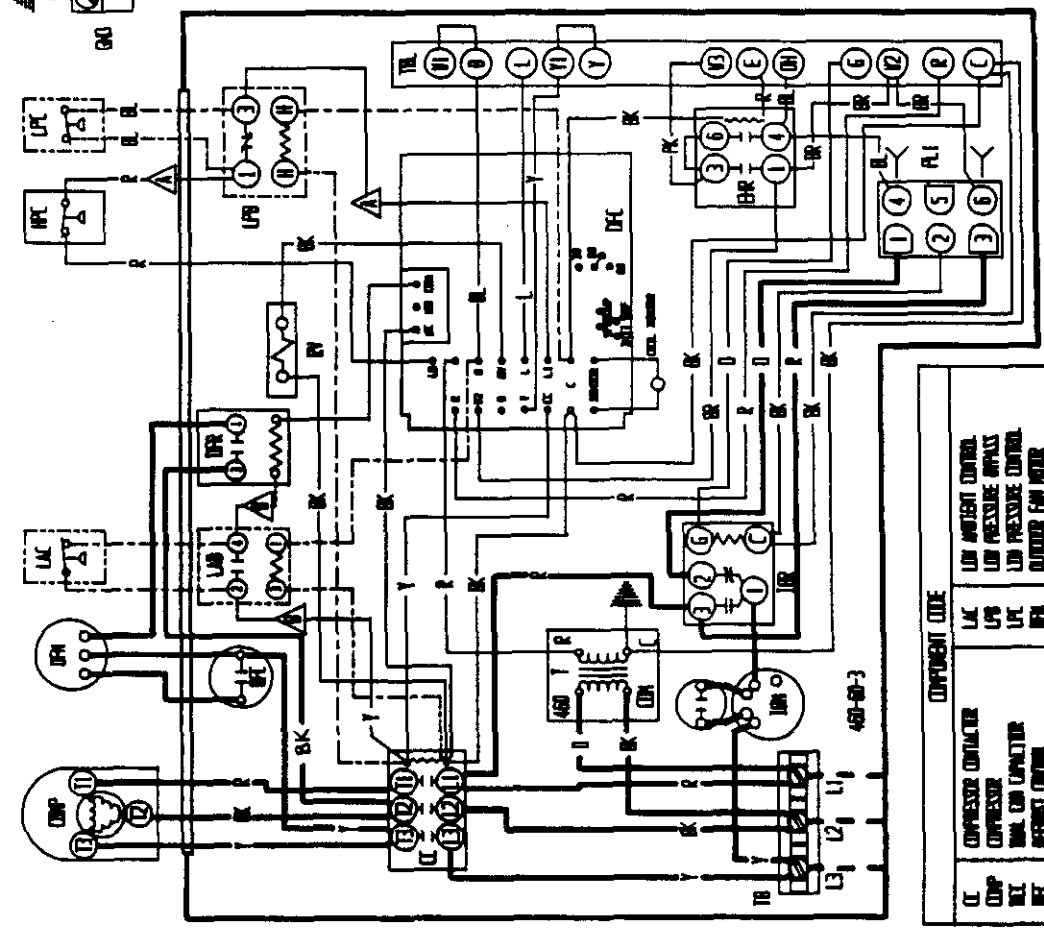

COMPONENT CODE	DESCRIPTION
C	COMPRESSOR CONTACTOR
COMP	COMPRESSOR
LAC	LOW AMBIENT CONTROL
LUC	LOW PRESSURE SWITCH
LVC	LOW PRESSURE CONTROL
LWC	LOW PRESSURE CONTROL
FAN	OUTDOOR FAN MOTOR
FR	FAN RELAY
FSC	FAN SPEED CONTROL
FSP	FAN SPEED POTENTIOMETER
FSB	FAN SPEED FEEDBACK
FSBR	FAN SPEED FEEDBACK RELAY
FSBC	FAN SPEED FEEDBACK CAPACITOR
FSBM	FAN SPEED FEEDBACK MOTOR
FSBR	FAN SPEED FEEDBACK RELAY
FSFC	LOW AMBIENT PRESSURE CONTROL

▲, ▲ LABELED WIRES CONNECT IF NO OPTIONS USED.

WIRE COLOR	FACTORY WIRE	FIELD	OPTIONAL
BLACK	---	---	---
BROWN	---	---	---
RED	---	---	---
ORANGE	---	---	---
WHITE	---	---	---
BLUE	---	---	---
GRAY	---	---	---
GREEN	---	---	---
PURPLE	---	---	---
YELLOW	---	---	---
VIOLLET	---	---	---
PINK	---	---	---
LAVENDER	---	---	---

▲ RED (LOW) BLACK (HIGH) WIRE APPLICABLE

WIRE COLOR	FACTORY WIRE	FIELD	OPTIONAL
BLACK	---	---	---
BROWN	---	---	---
RED	---	---	---
ORANGE	---	---	---
WHITE	---	---	---
BLUE	---	---	---
GRAY	---	---	---
GREEN	---	---	---
PURPLE	---	---	---
YELLOW	---	---	---
VIOLLET	---	---	---
PINK	---	---	---
LAVENDER	---	---	---

BARD INC. CO.

WKS. 408-311	DR. DR.	CHK./APPR.
--------------	---------	------------

