

INSTALLATION INSTRUCTIONS

MODELS

WERV-A5A

WERV-C5A

WALL MOUNT ENERGY RECOVERY VENTILATORS WITH EXHAUST

**FOR USE WITH BARD 3-1/2 THRU 5 TON
WALL MOUNT AIR CONDITIONERS
AND HEAT PUMPS**

DATE: 04-12-94

MANUAL 2100-236 REV. A
SUPERSEDES REV.
FILE VOL. III, TAB 19

TABLE OF CONTENTS

Model Nomenclature Legend	1
Electrical Specification.	1
General Description	1
Performance Data.	2
General Information	3
Unpacking	3
Basic Installation (Field Installation)	3
Basic Installation (Factory Installed Version).	7
Control Options12
Ventilation Air Flow.12
Servicing the WERV System12
Energy Transfer Wheel12

FIGURES and TABLES

Figure 1 . . Exhaust Blower Assembly	4
Figure 2 . . Wall Mount Unit Access Door	5
Figure 3 . . Filter and Exhaust Cover Plate.	6
Figure 4 . . Exhaust Blower Assembly Installation.	8
Figure 5 . . Wire Routing and Ventilator Positioning	9
Figure 6 . . Control Panel Wiring and Control Location	10
Figure 7 . . Service Access Panel and Fresh Air Intake Hood.	11
Figure 8 . . Airflow Path.	11
Table 1 . . WERV Ventilation Air Tables	12

Manufactured under the following U.S. patent numbers:
5,301,744; 5,002,116; 4,924,934; 4,875,520; 4,825,936; 4,432,409.
Other patents pending.

COPYRIGHT APRIL, 1994
BARD MANUFACTURING COMPANY
BRYAN, OHIO USA 43506

MODEL NOMENCLATURE LEGEND

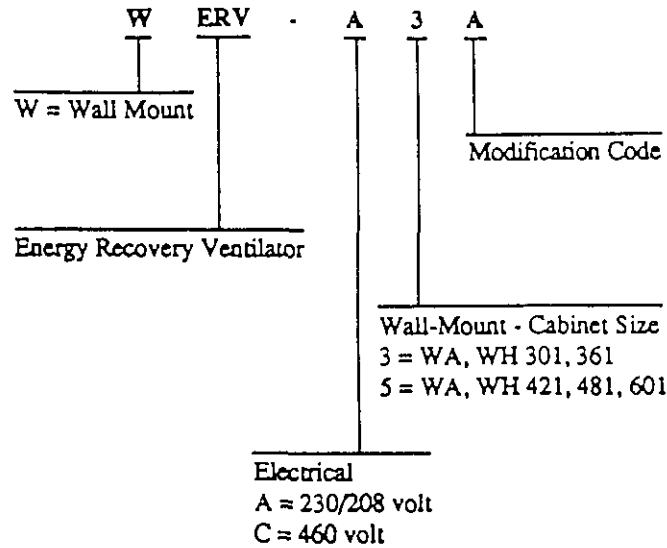

ELECTRICAL SPECIFICATIONS

Model	Voltage	Amps	Control Voltage
WERV-A3A	230/208	2.2	24V
WERV-C3A	460	1.2	24V
WERV-A5A	230/208	2.2	24V
WERV-C5A	460	1.2	24V

GENERAL DESCRIPTION

The Wall Mount Energy Recovery Ventilator was designed to provide energy efficient, cost effective ventilation to meet I.A.Q. (Indoor Air Quality) requirements while still maintaining good indoor comfort and humidity control for a variety of applications such as schools, classrooms, lounges, conference rooms, beauty salons and others. It provides a constant supply of fresh air for control of airborne pollutants including CO₂, smoke, radon, formaldehyde, excess moisture, virus and bacteria.

The ventilator incorporates patented rotary heat exchange state-of-the-art technology to remove both heat and moisture.

It is designed as a single package which can be easily factory or field installed for new installations or retrofit to the new Bard WA and WH series wall mounted units. The package consists of a unique rotary Energy Recovery Cassette that can be easily removed for cleaning or maintenance. It has two 13 inch diameter heat transfer wheels for efficient heat transfer. The heat transfer wheels use a permanently bonded dry desiccant coating for total heat recovery.

Ventilation is accomplished with (2) blower/motor assemblies each consisting of a drive motor and dual blowers for maximum ventilation at low sound levels. Air is exhausted at the same rate that fresh air is brought into the structure thus not pressuring the building. The rotating energy wheels provides the heat transfer effectively during both summer and winter conditions. Provides required ventilation to meet the requirements of ASHRAE 62-1989 standard.

NOTE: Operation is not recommended below 5 degrees F outdoor temperature because freezing of moisture in the heat transfer wheel can occur.

PERFORMANCE & APPLICATION DATA

Summer Cooling Performance
(Indoor Design Conditions 75°DB/62°WB)

Ambient O.D.	VENTILATION RATE -- 450 CFM 65% Efficiency						VENTILATION RATE -- 375 CFM 66% Efficiency						VENTILATION RATE -- 300 CFM 67% Efficiency								
	DB/WB°F	VLT	VLS	VLL	HRT	HRS	HLR	VLT	VLS	VLL	HRT	HRS	HLR	VLT	VLS	VLL	HRT	HRS	HLR		
75	21465			6884	13952		4475	17887			5737	11805		3786	14310			4590	9587		3075
105 70	14580	14580		0	9477	9477	0	12150	12150	0	8018	8018	0	0	9720	9720	0	6512	6512	0	0
65	14580			0	9477		0	12150			0	8018		0	9720			0	6512		0
80	31590			19440	20533		12635	26325			16200	17374		10692	21060			12960	14110		8683
75	21465			9314	13952		6054	17887			7762	11805		5123	14310			6210	9587		4160
100 70	12352	12150		202	8029	7897	131	10293	10125	168	6793	6682	111	8235	8100	135	5517	5427	5427	90	0
65	12150			0	7897		0	10125			0	6682		8100			0	5427		0	0
60	12150			0	7897		0	10125			0	6682		8100			0	5427		0	0
80	31590			21870	20533		14215	26325			18225	17374		12028	21060			14580	14110		9768
75	21465			11744	13952		7634	17887			9787	11805		6459	14310			7830	9587		5246
95 70	12352	9720		2632	8029	6318	1711	10293	8100	2193	6793	5345	1447	8235	6480	1755	5517	4341	4341	1175	0
65	9720			0	6318		0	8100			0	5345		6480			0	4341		0	0
60	9720			0	6318		0	8100			0	5345		6480			0	4341		0	0
80	31590			24300	20533		15794	26325			20250	17374		13365	21060			16200	14110		10854
75	21465			14175	13952		9213	17887			11812	11805		7796	14310			9450	9587		6331
90 70	12352	7290		5062	8029	4738	3290	10293	6075	4218	6793	4009	2784	8235	4860	3375	5517	3256	3256	2261	0
65	7290			0	4738		0	6075			0	4009		4860			0	3256		0	0
60	7290			0	4738		0	6075			0	4009		4860			0	3256		0	0
80	31590			26730	20533		17374	26325			22275	17374		14701	21060			17820	14110		11939
75	21465			16605	13952		10793	17887			13837	11805		9132	14310			11070	9587		7416
85 70	12352	4860		7492	8029	3159	4870	10293	4050	6243	6793	2672	4120	8235	3240	4995	5517	2170	2170	3346	0
65	4860			0	3159		0	4050			0	2672		3240			0	2170		0	0
60	4860			0	3159		0	4050			0	2672		3240			0	2170		0	0
75	21465			19035	13952		12372	17887			15862	11805		10469	14310			12690	9587		8502
80 70	12352	2430		9922	8029	1579	6449	10293	2025	8268	6793	1336	5457	8235	1620	6615	5517	1085	1085	4432	0
65	4252			1822	2764		1184	3543			1518	2338		2835			1215	1899		814	0
60	2430			0	1579		0	2025			0	1336		1620			0	1085		0	0
70	12352			12352	8029		8029	10293			10293	6793		6793	8235			8235	5517		5517
75 65	4252	0		4252	2764	0	2764	3543	0		3543	2338	0	2338	2835	0		2835	1899	0	1899
60	0			0	0		0	0			0	0		0				0	0		0

Winter Heating Performance
(Indoor Design Conditions 70°F DB)

Ambient O.D.	VENTILATION RATE					
	450 CFM 80% Eff		375 CFM 81% Eff		300 CFM 82% Eff	
DB°F	WVL	WHR	WVL	WHR	WVL	WHR
65	2430	1944	2025	1640	1620	1328
60	4860	3888	4050	3280	3240	2656
55	7290	5832	6075	4920	4860	3985
50	9720	7776	8100	6561	6480	5313
45	12150	9720	10125	8201	8100	6642
40	14580	11664	12150	9841	9720	7970
35	17010	13608	14175	11481	11340	9298
30	19440	15552	16200	13122	12960	10627
25	21870	17496	18225	14762	14580	11955
20	24300	19440	20250	16402	16200	13284
15	26730	21384	22275	18042	17820	14612

LEGEND

VLT = Ventilation Load - Total
VLS = Ventilation Load - Sensible
VLL = Ventilation Load - Latent
HRT = Heat Recovery - Total
HRS = Heat Recovery - Sensible
HLR = Heat Recovery - Latent
WVL = Winter Ventilation Load
WHR = Winter Heat Recovery

NOTE: Sensible performance only is shown for winter application.

GENERAL INFORMATION

The ventilator should only be installed by a trained heating and air conditioning technician. These instructions serve as a guide to the technician installing the ventilator package. They are not intended as a step by step procedure with which the mechanically inclined owner can install the package.

The ventilator housing is shipped in one carton which contains the following:

1. Ventilator and exhaust blower assembly
2. Service Door
3. Rain Hood and Mist Eliminator
4. Installation Instructions

UNPACKING

Upon receipt of the equipment, be sure to compare the model number found on the shipping label with the accessory identification information on the ordering and shipping document to verify that the correct accessory has been shipped.

Inspect the carton housing of each ventilator as it is received, and before signing the freight bill, verify that all items have been received and that there is no visible damage. Note any shortages or damage on all copies of the freight bill. The receiving party must contact the last carrier immediately, preferably in writing, requesting inspection by the carrier's agent. Concealed damage not discovered until after loading must be reported to the carrier within 15 days of its receipt.

BASIC INSTALLATION (Field Installation)

1. Unpack the ventilator assembly which includes the integral ventilator with attached electrical harness and miscellaneous hardware.

WARNING		
Open and lock unit disconnect switch before installing this accessory to prevent injury or death due to electrical shock or contact with moving parts. Turn thermostat to off.		

<u>MODEL</u>	<u>For Use With Following Units</u>	<u>Electrical</u>
WERV-ASA	WA421-A,-B WH421-A,-B WA481-A,-B WH481-A,-B WA601-A,-B WH601-A,-B	230/208-1 or 3 phase
WERV-CSA	WA421-C WH421-C WA481-C WH481-C WA601-C WH601-C	460-3 phase

CAUTION: Be sure the correct model and voltage Energy Recovery Ventilator is used with the correct air conditioner or heat pump to insure correct voltage compatibility.

2. Remove exhaust blower assembly from back of ventilator and discard shipping plate. See Figure 1.

FIGURE 1

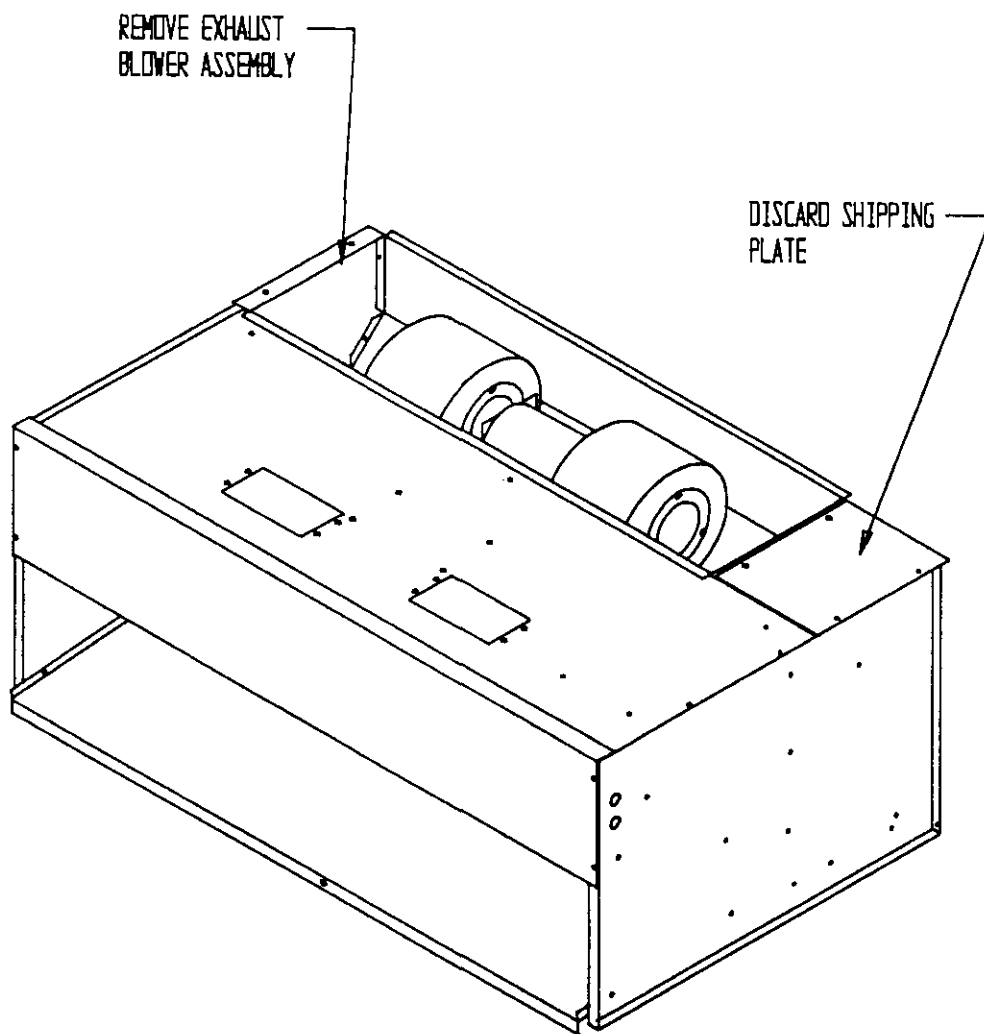

3. Remove the existing exterior blower access and service access panels on the Bard wall mount units. Save the blower access panel and discard service access panel. (See Figure 2)

FIGURE 2

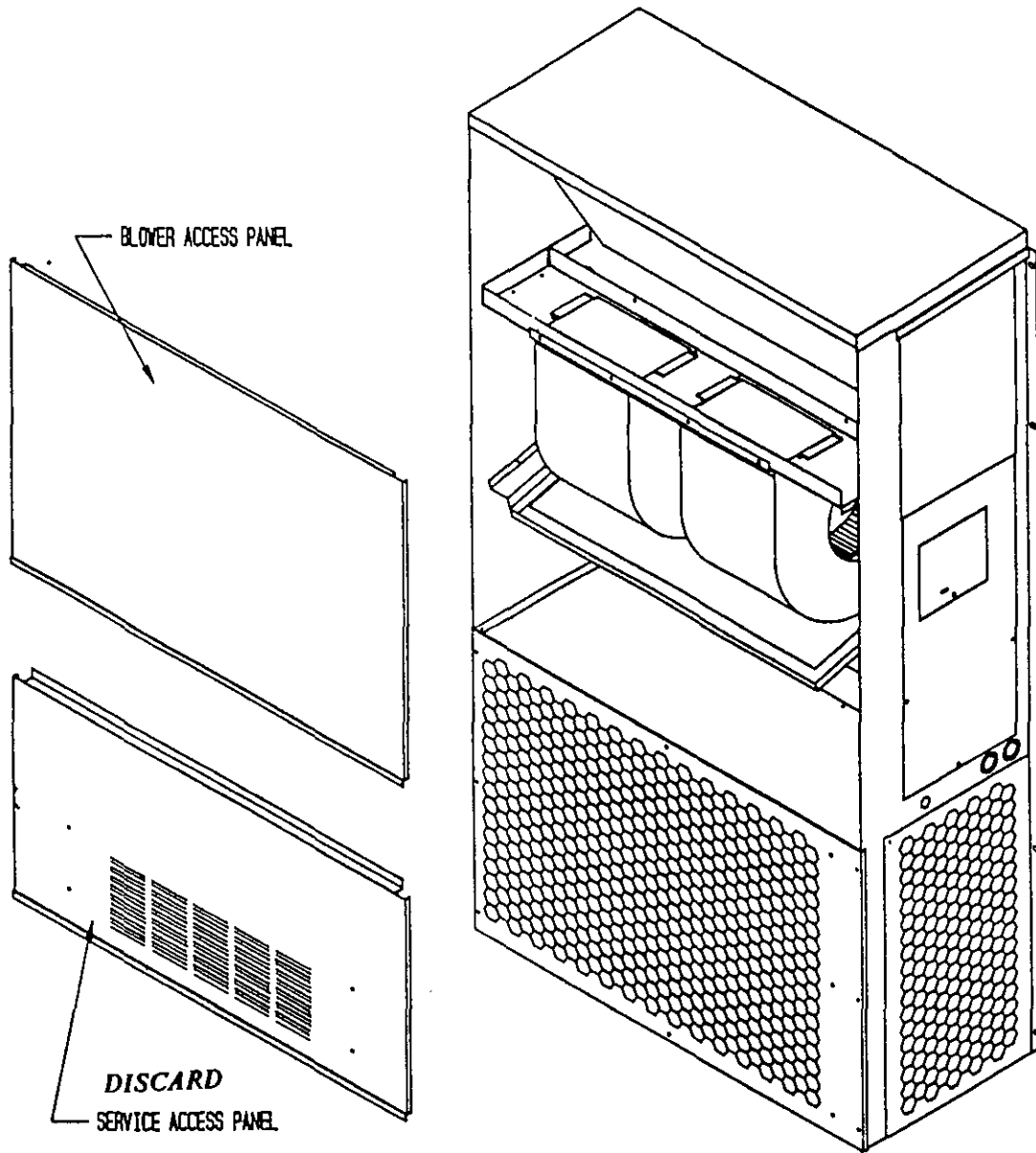

4. Remove and save existing unit air filter. Remove and discard the exhaust cover plate and remove center screw from condenser grill. (See Figure 3)

FIGURE 3

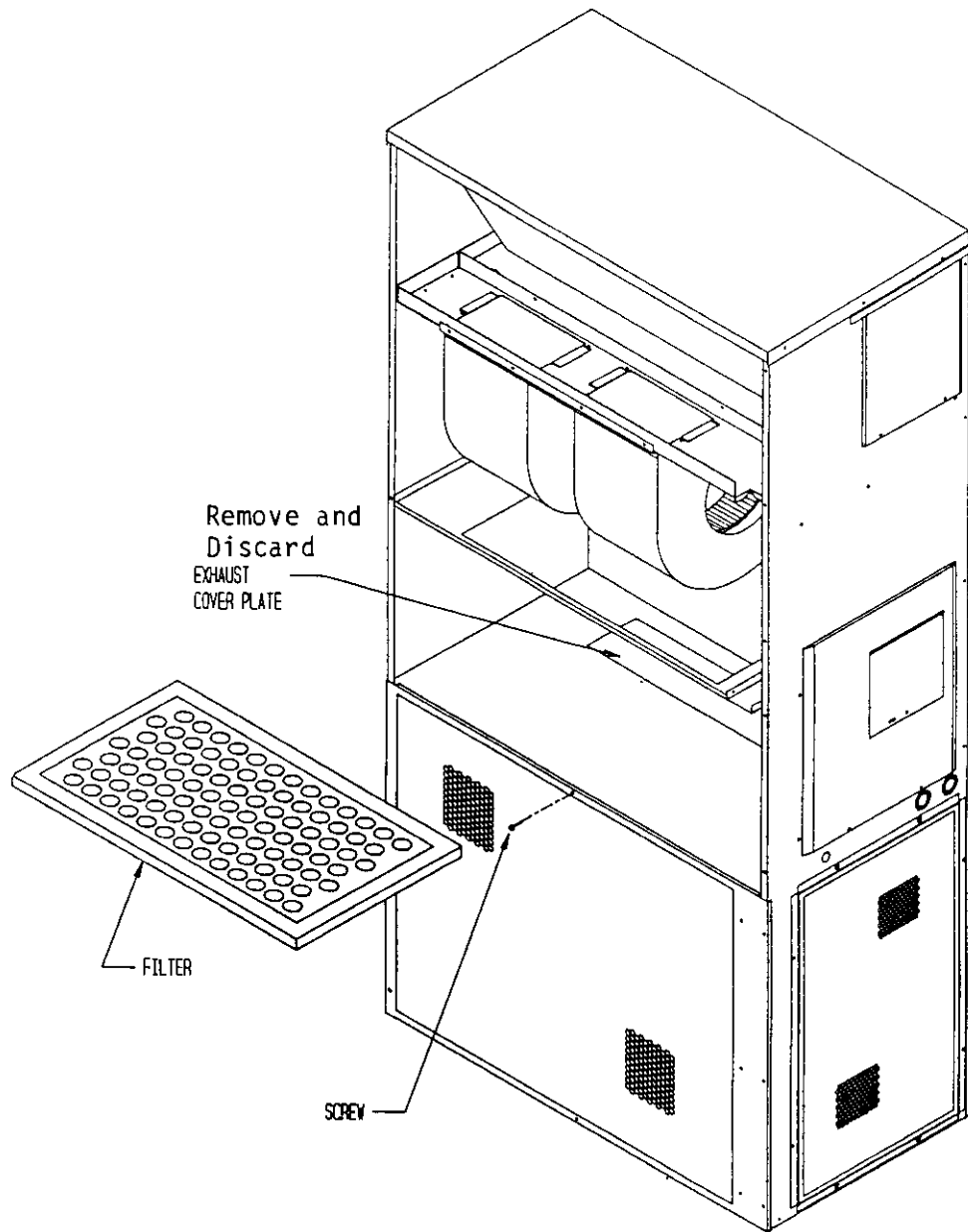

5. Install exhaust blower assembly in exhaust opening and secure with four (4) screws. Position 4 pin connector so it is accessible. See Figure 4, page 8.
6. Install ventilator into the unit to the left side. Once the ventilator is fully inserted, slide the ventilator to the right until it is tight against the back of the control panel. (Figure 5, page 9)

IMPORTANT: Position front lip of ventilator over front grille and on top of condenser partition. (See Figure 5 inset) This is important to ensure proper drainage of any water entering damper assembly.
7. Open control panel to gain access to unit low voltage terminal block. (Insure all power is off prior to opening the control panel.)
8. Route electrical harness leads thru the 7/8" bushing in control panel (Figure 5) into low voltage box.
9. Connect leads with fork terminal to corresponding points on terminal strip to terminals C and G. (See Figure 6, page 10 and wiring diagram.)

NOTE: These 24 volt control wires control the starting and stopping of the Energy Recovery Ventilator and can be independently controlled by an energy management control or timer. See separate section on Control Wiring.
10. Remove female plug section of high voltage wiring harness and snap into unit control panel. Wire to terminal block. See Figure 6 and wiring diagram.
11. Plug male plug into female at side of control panel. (See Figure 5)
12. Close control panel cover
13. Replace filter and one (1) screw in condenser grille. (See Figure 3)
14. Ventilator Checkout
 - A. Resupply power to unit.
 - B. Energize the evaporator blower by switching thermostat to the manual fan position with heat/cool in off position.
 - C. Ventilator heat transfer wheels should rotate slowly (49 RPM). Intake and exhaust blowers should run. (See Figure 8)
 - D. De-energize evaporator blower. Energy Recovery wheels and fresh air and exhaust air blowers should stop.
 - E. This completes ventilator checkout.
15. Reinstall the blower access panel at top of unit and secure with sheet metal screws. (See Figure 2)
16. Replace the lower service access panel with the new panel provided. Attach air intake hood with screws provided. (See Figure 7) Be sure to insert the top flange of the air intake hood into and thru the slot in the service door and between the door and insulation to prevent bowing of the door.

BASIC INSTALLATION (FACTORY INSTALLED VERSIONS)

1. Remove blower access door and service door. Room filter located above air circulating blowers. Install filter.
2. Remove and install air intake hood--refer to item 15 above.
3. Replace all panels.

FIGURE 4

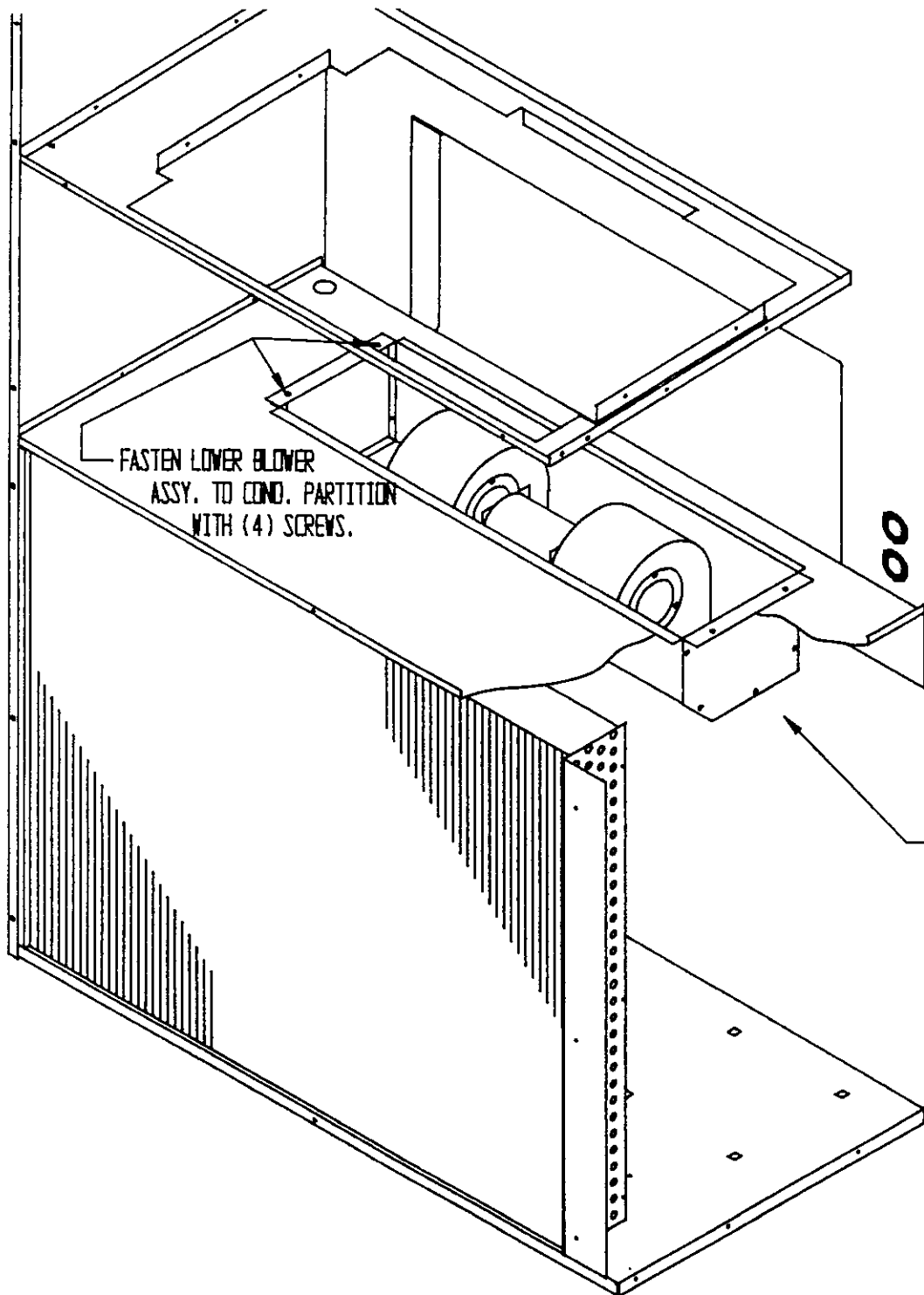

FASTEN LOWER BLOWER
ASSY. TO COND. PARTITION
WITH (4) SCREWS.

RIGHT SIDE REMOVED
FOR CLARITY

CONDENSOR PARTITION CUT
AWAY SO TO SHOW HRV LOWER
BLOWER ASSY. RELATIONSHIP
TO UNIT.
(IMPORTANT)
MITRED EDGE TOWARDS COND.
COIL

FIGURE 5

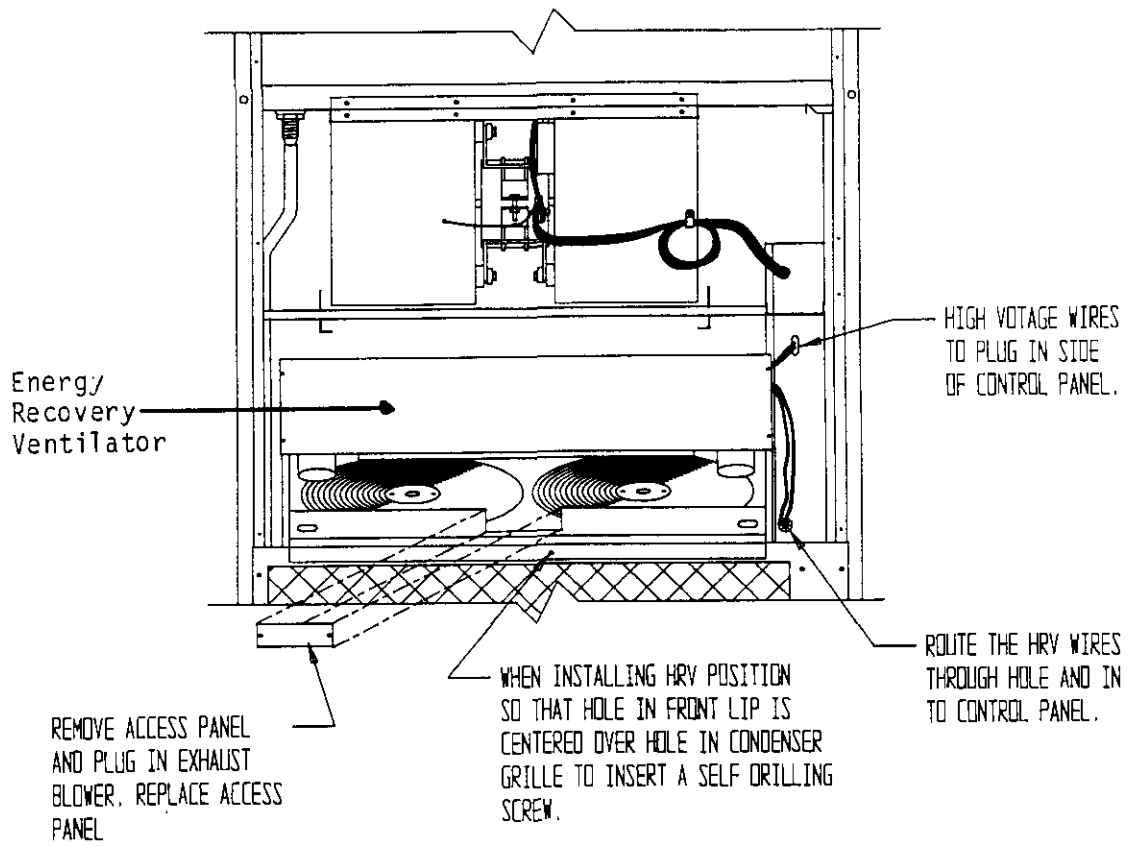

FIGURE 5
INSET

CAUTION: HOLE IN HRV MUST BE USED TO INSURE CLEARANCE FROM CONDENSER COIL TUBING.

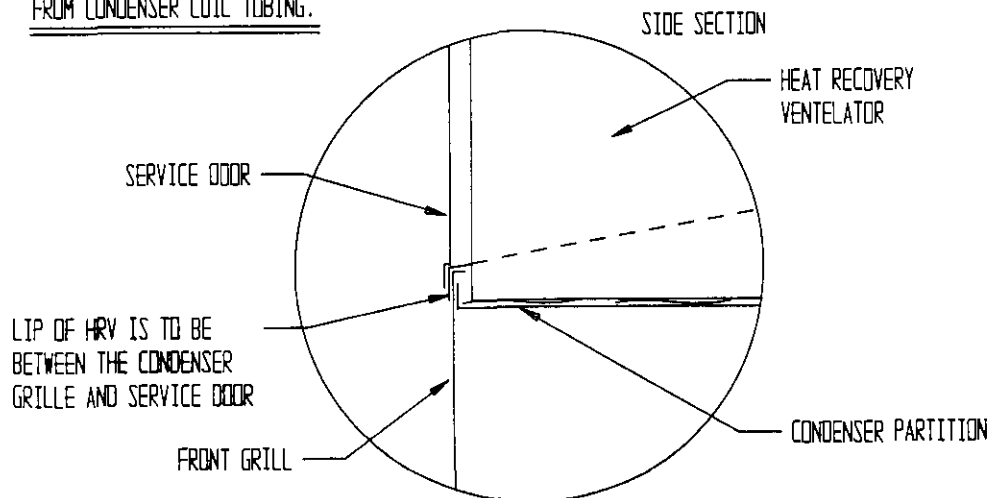
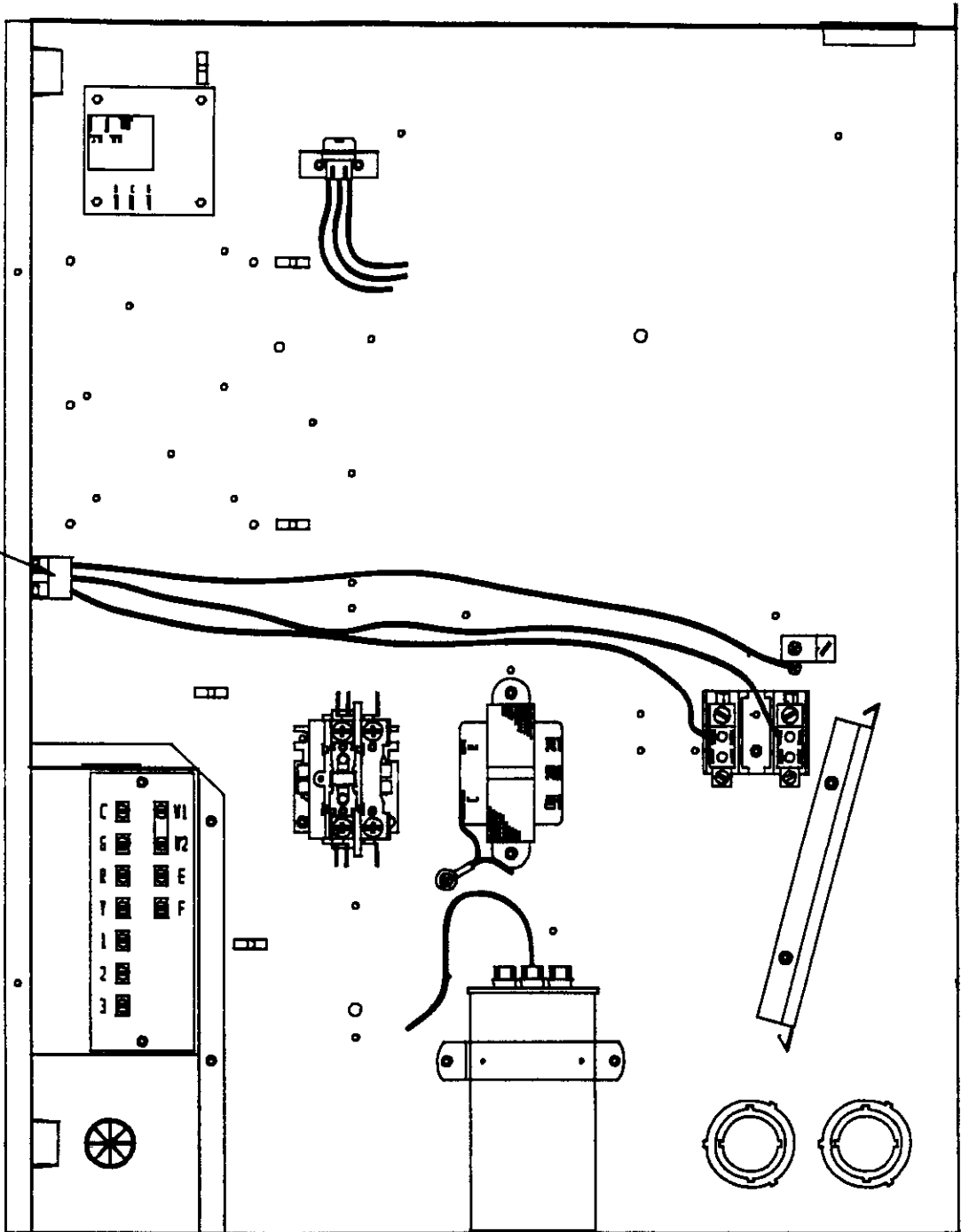

FIGURE 6

INSTALL 1-480701-0 CAP
AS SHOWN AND WIRE
PER WIRING DIAGRAM



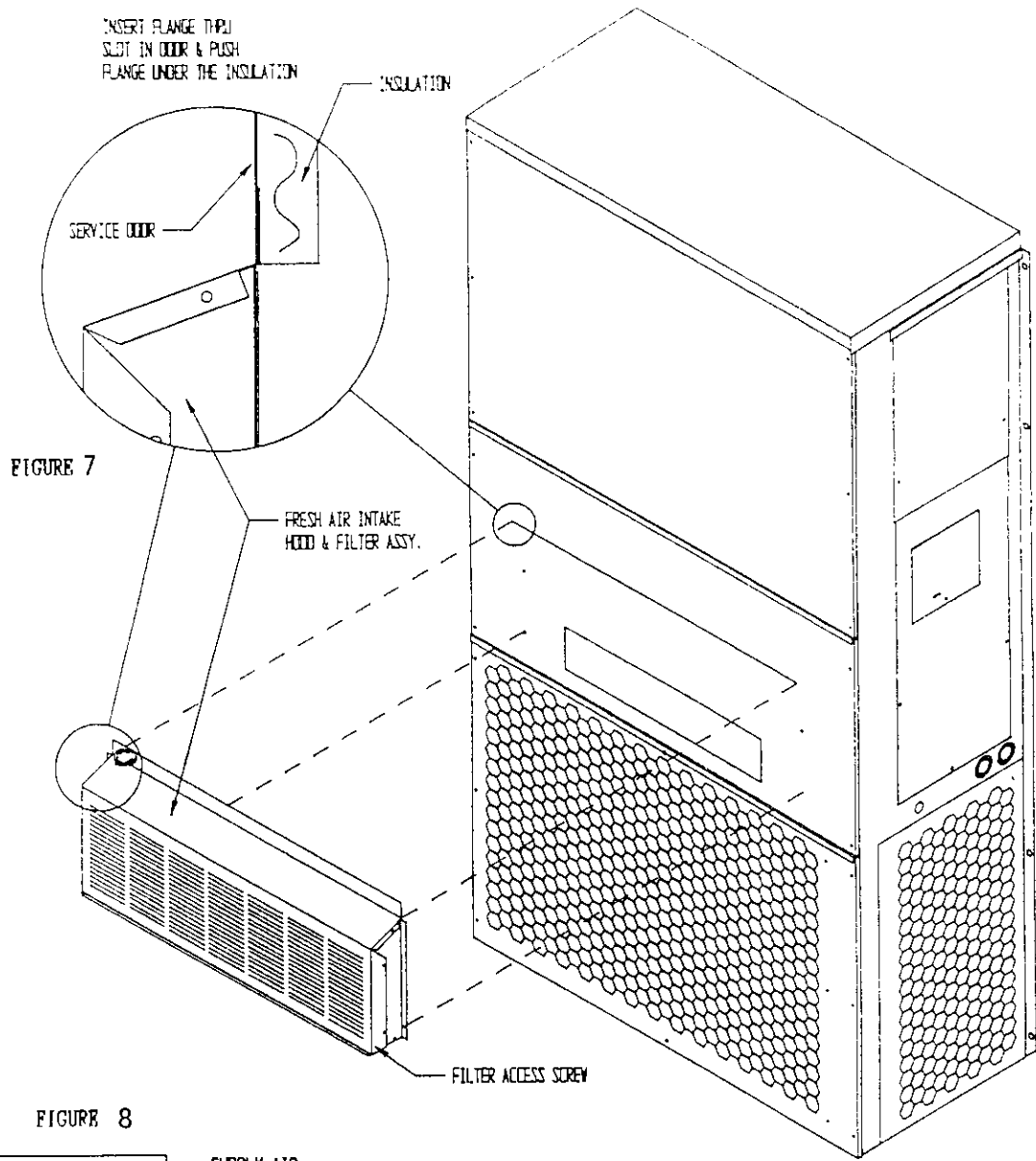
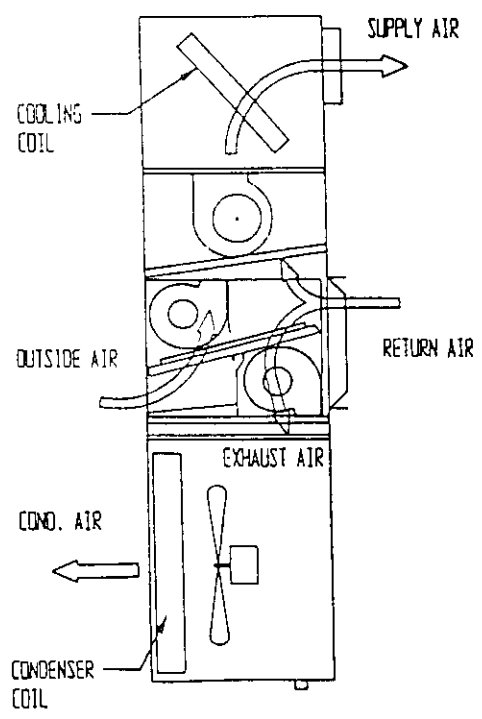

FIGURE 8



REPLACE SERVICE ACCESS PANEL AND INSTALL FRESH AIR INTAKE HOOD ASSY. AS SHOWN.

CONTROL OPTIONS

The unit comes from the factory wired to provide ventilation whenever the indoor blower of the air conditioner or heat pump is operating. Continuous ventilation can be obtained by setting the wall thermostat on continuous fan.

For many applications such as schools, it may be more desirable and will reduce the operating cost, to shut the ventilation system off during periods of time when the building or room is not occupied.

This can be accomplished by providing a means to interrupt the orange wire from control relay CR1 (see wiring diagram) to "G" on the unit 24 volt terminal block. This can be accomplished with a manual switch, timer, programmable thermostat, Bard CS2000 or separate energy management system.

VENTILATION AIR FLOW

The WERV-ASA and WERV-CSA is equipped with a 3 speed motor to provide the capability of adjusting the ventilation rates to the requirements of the specific application by simply changing motor speeds.

TABLE 1

VENTILATION AIR (CFM)			
	High Speed (Black)	Medium Speed (Blue)	Low Speed (Red)
CFM	450	375	300

The units are wired from the factory on high speed. The speed can be changed by disconnecting the black wire and reconnecting the blue or red wire on the intake or exhaust blower motor. If desired, the fresh air motor can be wired on one speed and the exhaust motor on another if needed for a specific requirement.

WARNING

Open disconnect to shut all power off before doing this. Failure to do so could result in injury or death due to electrical shock.

SERVICING THE WERV SYSTEM

1. Room air filters in the air conditioner should be cleaned or replaced periodically to maintain an adequate amount of total circulated air thru the air conditioning system. The frequency of changing or cleaning is dependent on the application.
2. Fresh air filter. The unit is equipped with a fresh air filter and mist eliminator located in the fresh air hood. (See Figure 7) This can be removed by removing the filter access screw from the side of the fresh air hood and removing the filter from the bottom of the assembly. This filter is constructed of an aluminum frame and mesh and can be cleaned by washing periodically. The frequency is determined by the amount of dust, pollen and other outdoor airborne particles in the area. A periodic visual inspection is recommended to insure it is clean and free of dust, debris, leaves, snow etc.

ENERGY TRANSFER WHEEL

NOTE: Discoloration and staining of the wheel does not affect its performance. Only excessive build-up of foreign material needs to be removed.

If the wheels appear excessively dirty, they should be cleaned to insure maximum efficiency. To clean the wheels, remove the service access panel (see Figure 2). Remove the sheet metal access panel on the front of the Energy Recovery Ventilator. Unplug the (2) wheel drive motors at the plug-in connectors located below the heat transfer wheels. (Squeeze the side tabs on the connector and pull gently--do not pull on the wires.) Remove the heat transfer cassette by grasping the tray and sliding out of the unit. Remove the wheels from the cassette assembly. Grasp the wheel by the rim and thoroughly spray the wheel windings with a household spray cleaner such as Fantastic or the equivalent. Gently rinse with warm water and use a soft brush (such as a paint brush) to remove any heavy accumulation. Shake the excess water from the wheel and reinstall in reverse order. Operate the unit to confirm proper operation.

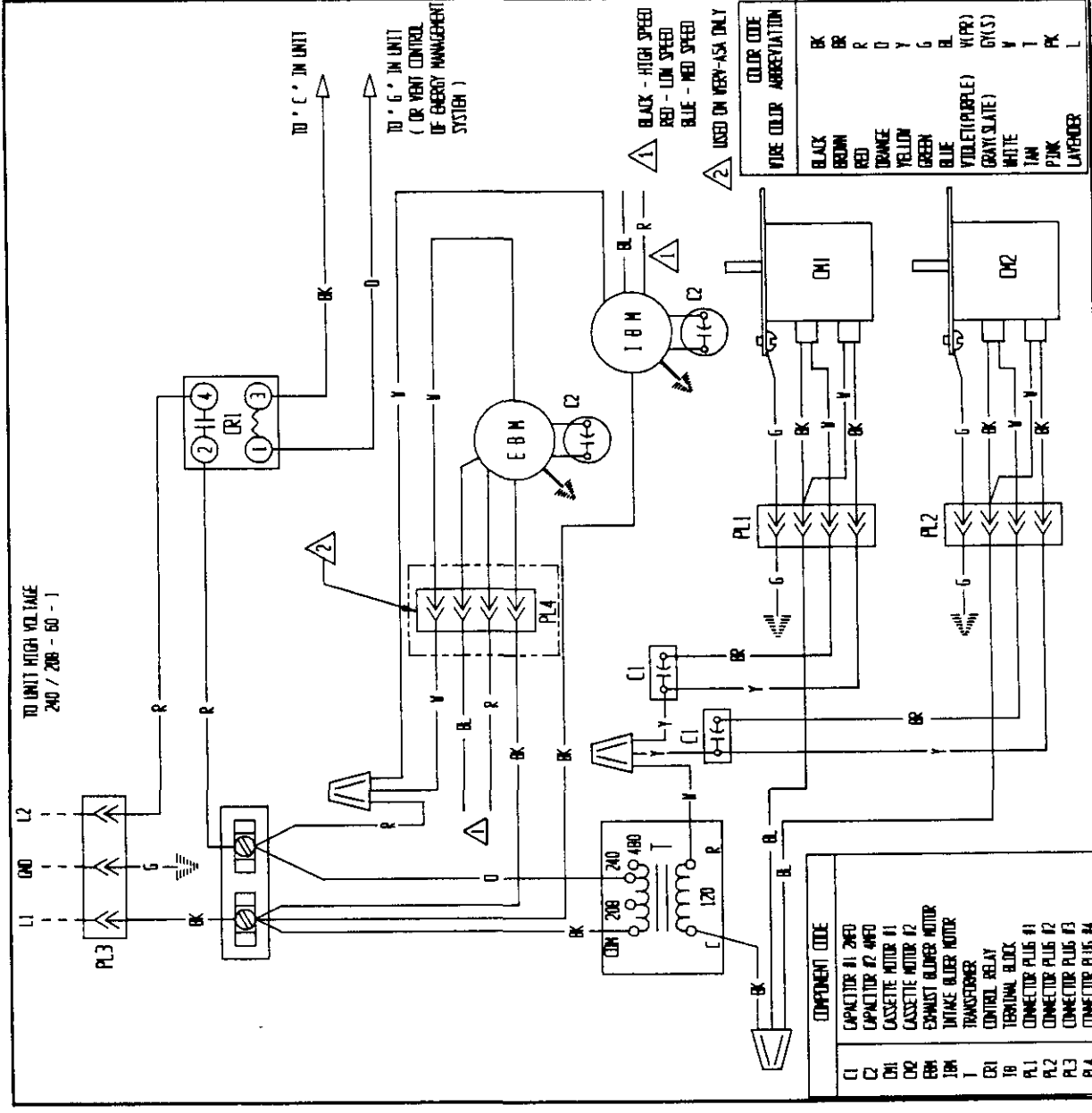
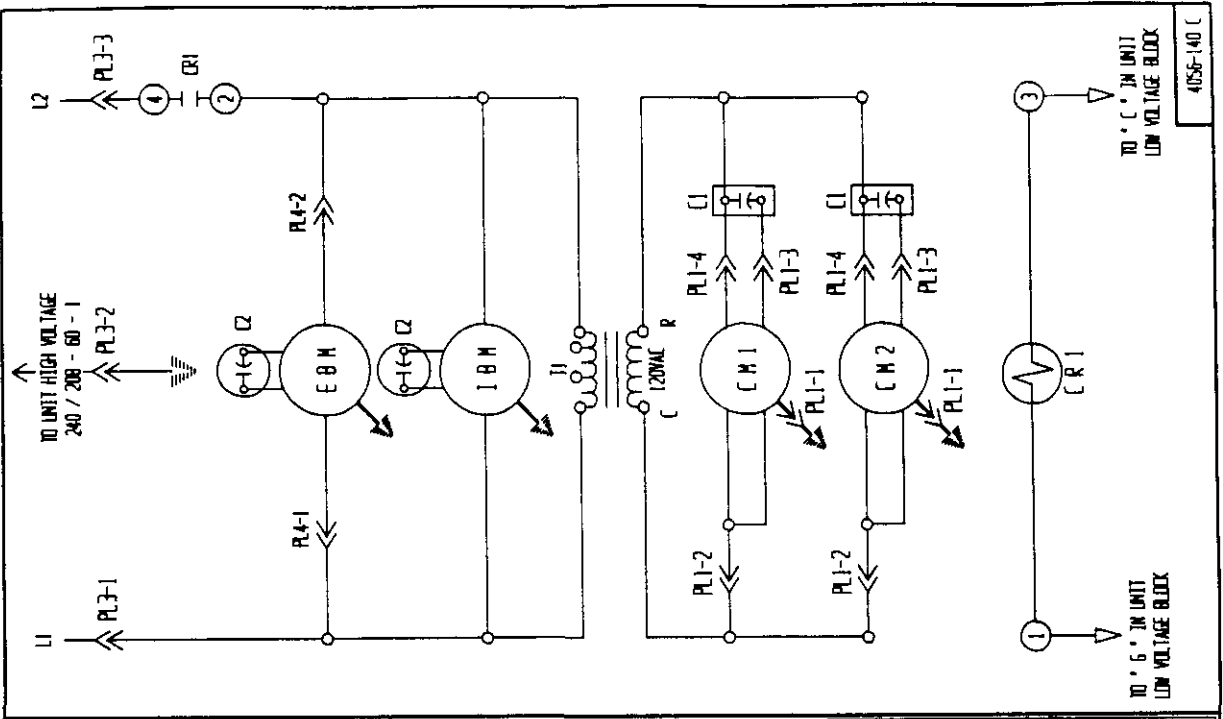

4056-140 C

TO 'G' IN UNIT
LOW VOLTAGE BLOCK

TO 'C' IN UNIT
LOW VOLTAGE BLOCK

TO 'C' IN UNIT

TO 'G' IN UNIT
(OR VENT CONTROL
OF ENERGY MANAGEMENT
SYSTEM)

▲ BLACK - HIGH SPEED
▲ RED - LOW SPEED
▲ BLUE - MED SPEED
▲ USED ON VERY-ASA ONLY

TO UNIT HIGH VOLTAGE
240 / 208 - 60 - 1

L1 L2

