

# **INSTALLATION INSTRUCTIONS**

**MODELS**

**EIFM-1**

**ECONOMIZERS WITH EXHAUST**

**FOR USE WITH BARD 1 TON  
WALL MOUNT AIR CONDITIONER**

DATE: 04-12-94

MANUAL 2100-237 REV. A  
SUPERSEDES REV.  
FILE VOL. III, TAB 19

## TABLE OF CONTENTS

General Information . . . . .	1
Unpacking . . . . .	1
Description . . . . .	1
Basic Installation . . . . .	2
Operating Check Out . . . . .	6
Features . . . . .	9
Economizer Sequence of Operation. . . . .	9
Wall Thermostats. . . . .	9
Operation Block Diagram . . . . .	10
Wiring Diagrams . . . . .	11 & 12

## FIGURES

Figure 1 . . Troubleshooting Chart . . . . .	10
Figure 2 . . Wall Mount Unit . . . . .	2
Figure 3 . . Filter Exhaust Cover Plate. . . . .	3
Figure 4 . . Wire Routing and Economizer Positioning . . . . .	4
Figure 5 . . Economizer Motor and Controls . . . . .	5
Figure 6 . . Seal Plate Installation . . . . .	8
Figure 7 . . Damper Position--Full Open . . . . .	13
Figure 8 . . Damper Position--Full Closed. . . . .	14

Manufactured under U.S. patent number 5,301,744.  
Other patents pending.

COPYRIGHT APRIL, 1994  
BARD MANUFACTURING COMPANY  
BRYAN, OHIO USA 43506

## GENERAL INFORMATION

The economizer should only be installed by a trained heating and air conditioning technician. These instructions serve as a guide to the technician installing the economizer package. They are not intended as a step by step procedure with which the mechanically inclined owner can install the package.

The economizer housing is shipped in one carton which contains the electrical harness, miscellaneous hardware, seal plate, and installation instructions.

The economizer installation requires an additional two stage cooling thermostat in place of the normal single stage cooling thermostat. Also additional low voltage wire will be required to transmit the second call (Y2) for cool. (I.E. use 6 conductor thermostat wire for an air conditioning unit). See Page 9 for required thermostats.

If using a Bard master controller, the MC91AE master controller is designed specifically to control two (2) redundant Bard wall mount units equipped with economizers.

Any wall mount unit equipped with an economizer must also have a low ambient control installed. This control can be factory installed or field installed. If field installed, use kit CMA-6 (air conditioner models).

## UNPACKING

Upon receipt of the equipment, be sure to compare the model number found on the shipping label with the accessory identification information on the ordering and shipping document to verify that the correct accessory has been shipped.

Inspect the carton housing of each economizer as it is received, and before signing the freight bill, verify that all items have been received and that there is no visible damage. Note any shortages or damage on all copies of the freight bill. The receiving party must contact the last carrier immediately, preferably in writing, requesting inspection by the carrier's agent. Concealed damage not discovered until after loading must be reported to the carrier within 15 days of its receipt.

## DESCRIPTION

The EIFM-1 economizer is designed to be used with Bard one ton wall mount series air conditioners equipped with low ambient fan cycling controls. NOTE: If unit is not equipped with low ambient control from factory, one must be installed. Order field installed low ambient kit CMA-6. It is an electro-mechanical economizer systems designed to provide "free" cooling where the outdoor air temperature is cool enough to provide the needed cooling without running the compressor. When cooling is needed, the system automatically takes advantage of the cold outdoor air when available and uses it for first stage cooling. This then reduces the need to run the air conditioning compressor providing lower operating costs and increasing the service life of the equipment. If the outdoor air gets too warm or humid to be helpful, the enthalpy control detects the condition and automatically closes the outdoor air and exhaust damper, opens the return air damper and switches to the compressor operation. This is all done automatically to achieve maximum savings without attention from the user. See Figure 1, Page 10 for a block diagram of the economizer operation logic flow. The unit is equipped with a full modulating type damper motor which controls the damper position to a factory set minimum supply air temperature.

MODEL:	<u>EIFM-1</u>
FOR USE WITH THE FOLLOWING UNIT	WA121

## BASIC INSTALLATION

1. Unpack the economizer assembly which includes the integral economizer with attached electrical harness, mixed air thermister and miscellaneous hardware and installation instructions.

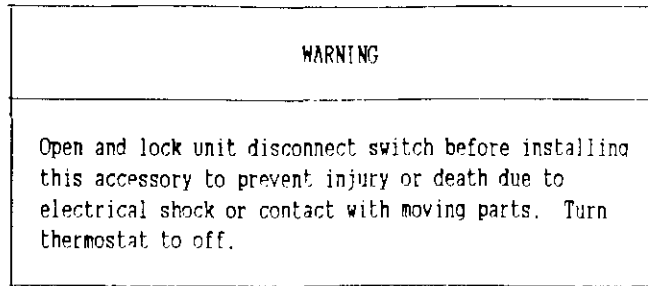

2. Remove and save the existing exterior service access panel on the Bard wall-mount unit. (See Figure 2)

FIGURE 2

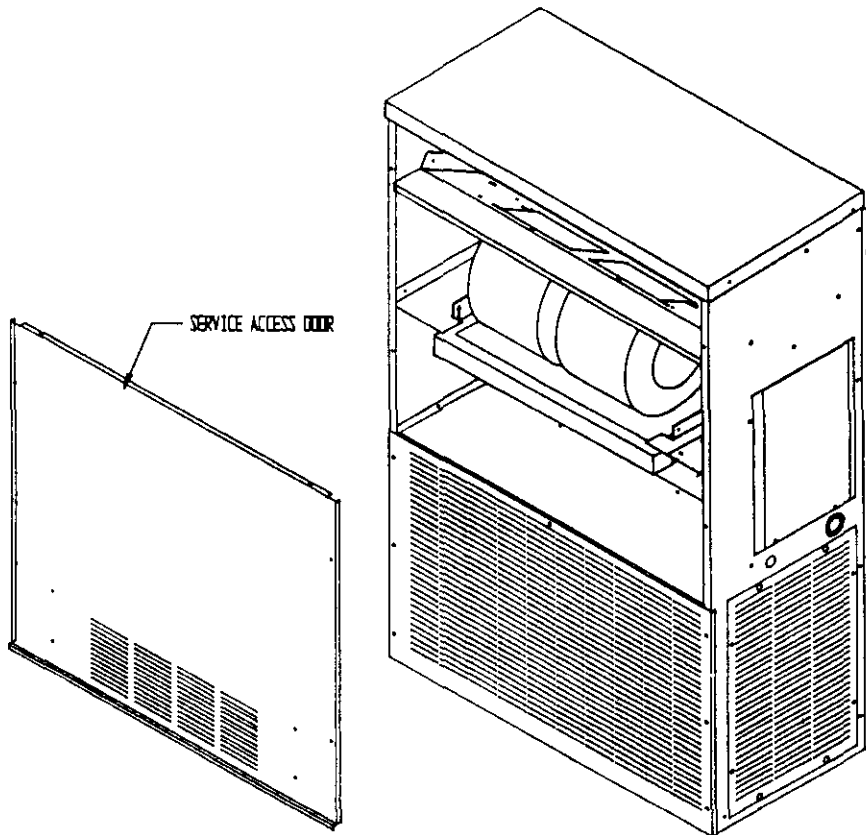

3. Remove and save existing right and left side filter support bracket. Remove and save filter.
4. REMOVE AND DISCARD THE EXHAUST COVER PLATE. (Figure 3)

FIGURE 3

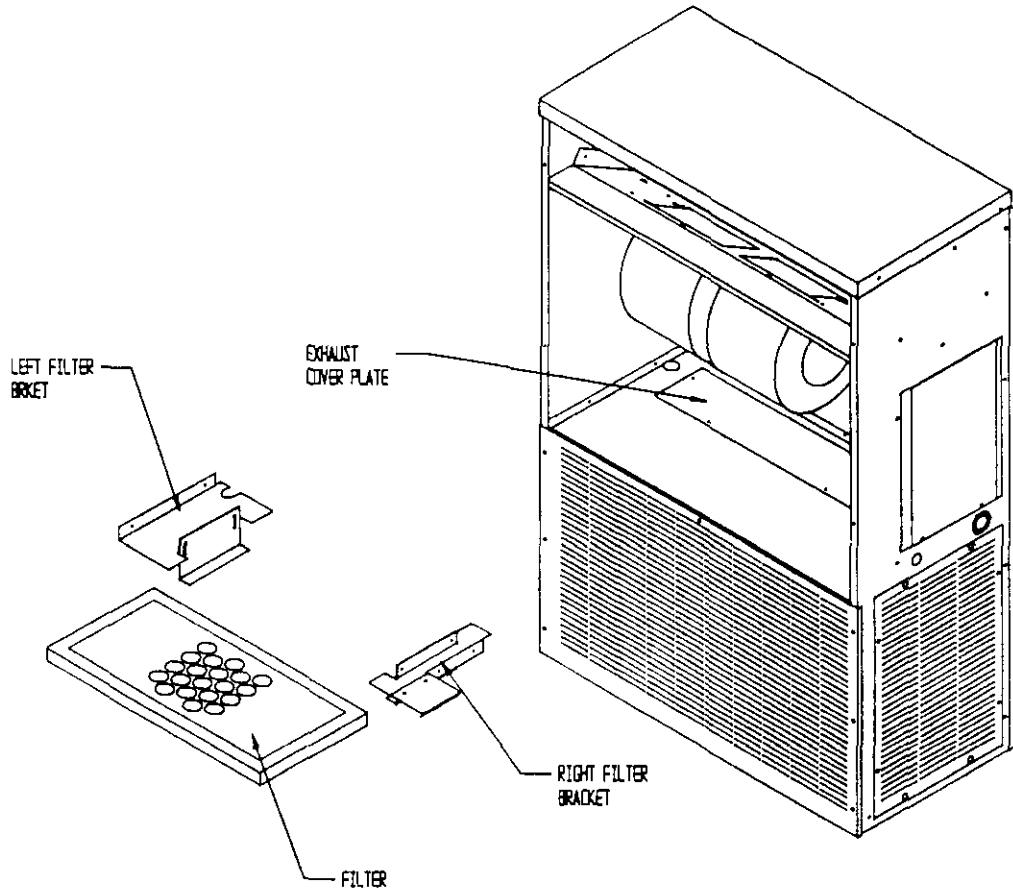
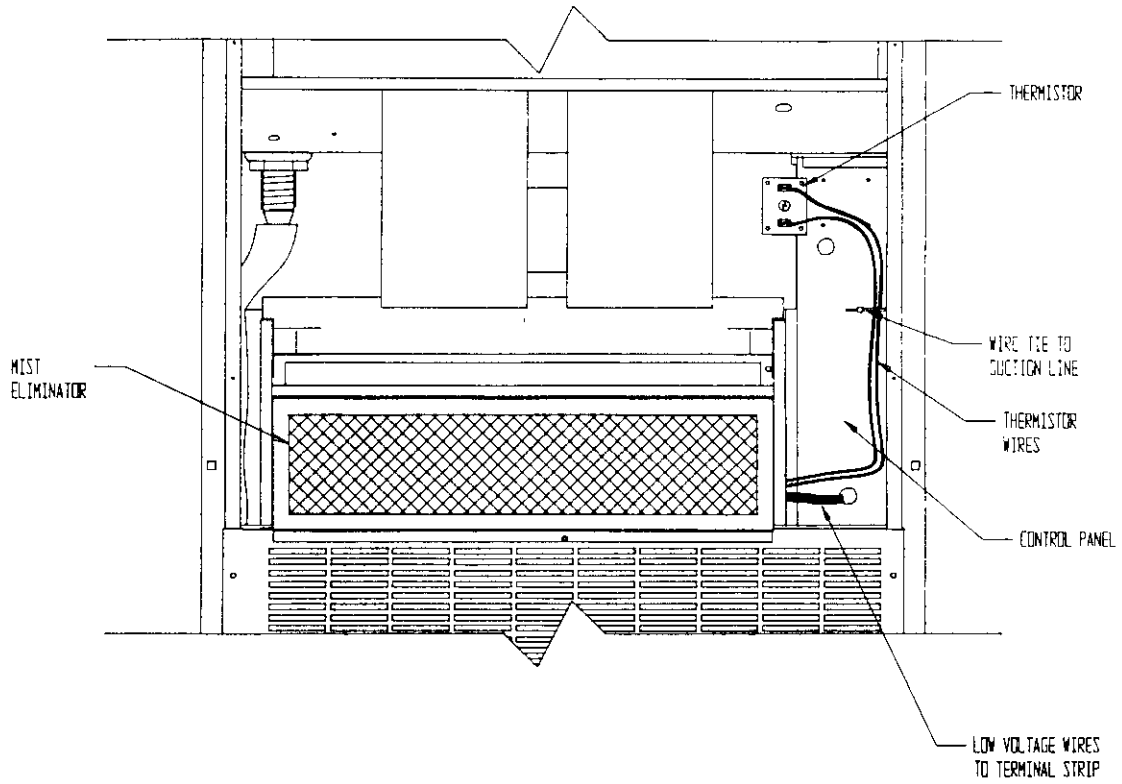

FIGURE 4

FRONT VIEW



SIDE SECTION

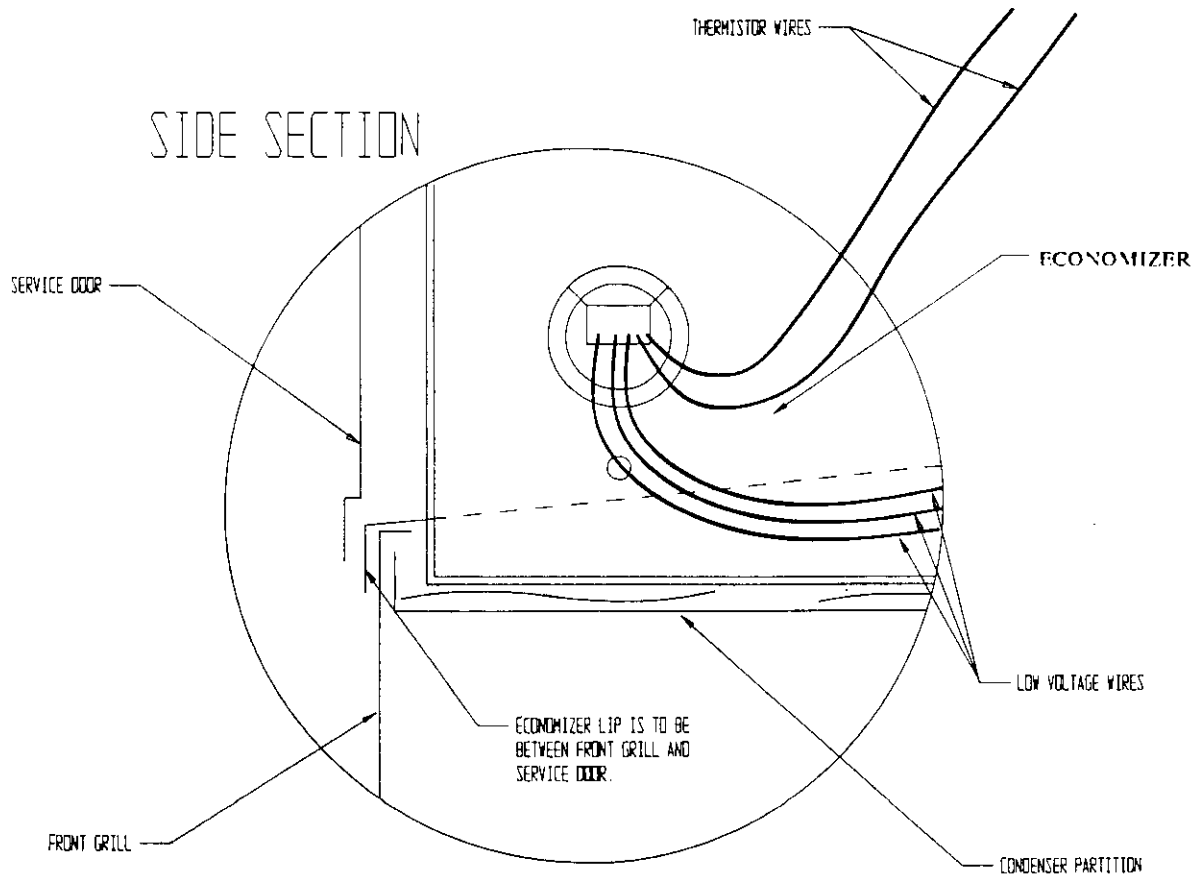

FIGURE 5

TOP VIEW OF CONTROL PANEL

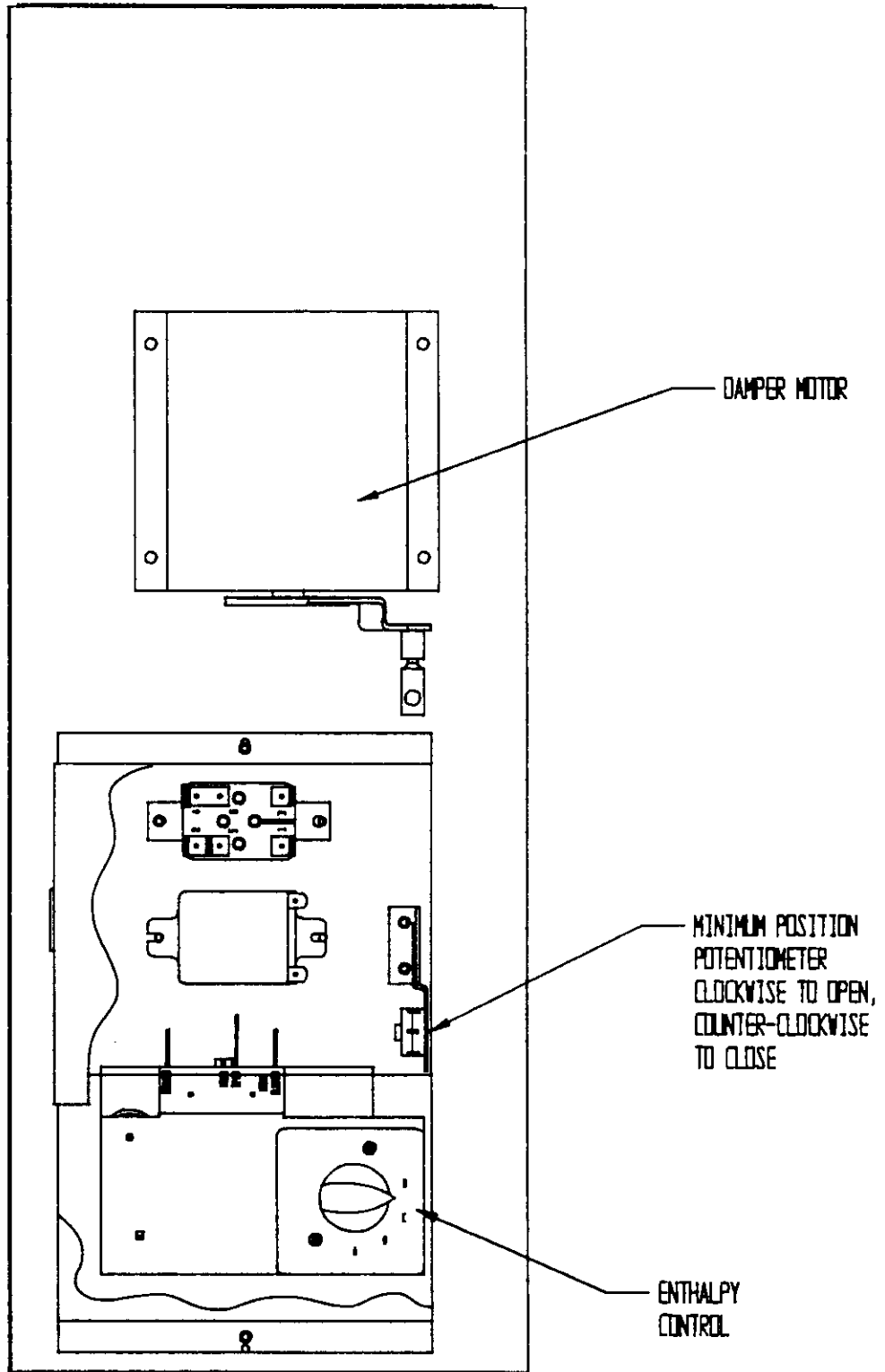
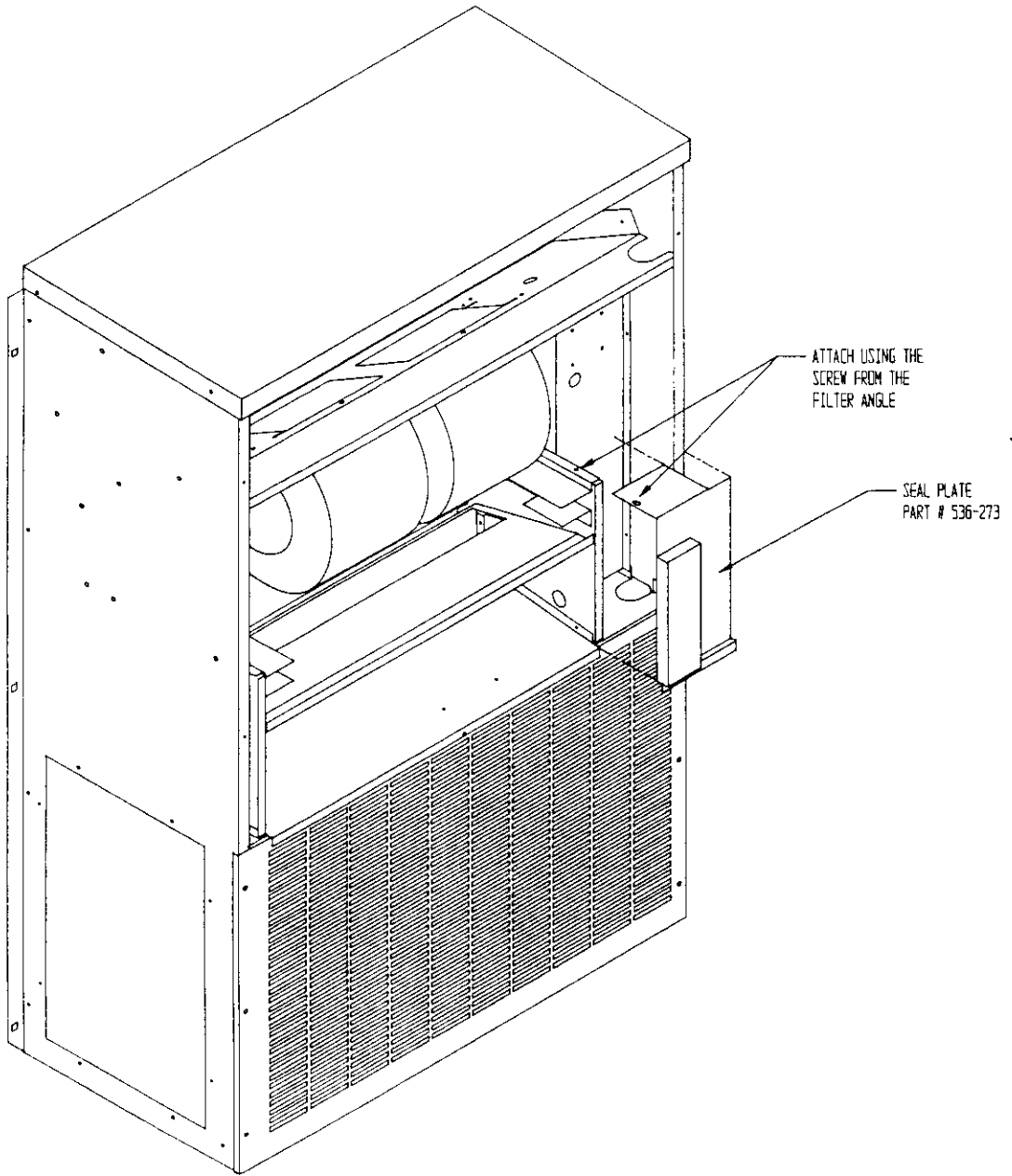

FIGURE 6





5. Install economizer by inserting the economizer into the unit to the far left side. Once the economizer is fully inserted, slide the economizer to the right until it is tight against the back of the control panel. (Figure 4)
- IMPORTANT:** Position front lip of economizer over front grille. (See Figure 4 inset) This is important to ensure proper drainage of any water entering damper assembly.
6. Mount mixed air thermistor to control panel as shown with screws provided. Route wires as shown and secure with wire tie. Connect wires to thermistor. (See Figure 4)
  7. Open unit control panel to gain access to unit low voltage terminal block.
  8. Route electrical harness leads thru the 7/8" bushing in control panel (Figure 4) into low voltage box.
  9. Connect leads with fork terminal to corresponding points on terminal strip, re: C,Y,G. (See wiring diagram on Page 11)
  10. Wire nut leads with 5/8" stripped ends to Y1 and Y2 leads from thermostat. See wiring diagram on page 11 or on economizer.
  11. Close control panel cover
  12. Remove one screw holding filter bracket on economizer and install seal plate (part No. 536-273). Replace screw. See Figure 6.
  13. Place filter in filter bracket supplied with economizer.

#### 14. ECONOMIZER CHECKOUT

- A. Remove mist eliminator. (See Figure 4) Locate the minimum position potentiometer. (See Figure 5)
- B. Energize the evaporator blower by switching the thermostat to the manual fan position with the heat/cool switch in the off position.
- C. Cycle the minimum position potentiometer (factory set for 0% fresh air) 0 to full open. (See Figure 5) Throughout checkout procedure observe operation of damper to insure there is free, unobstructed operation through the entire angle of damper travel. Then adjust the damper minimum open position to meet local codes or application requirements. (See example below)

##### EXAMPLE:

1. Measure return air temperature (RAT) (assume 75°F for example)
2. Measure outdoor air temperature (OAT) (assume 60°F for example)
3. Calculate the mixed air temperature (MAT) which will result from the desired combination of OAT (10 percent) and RAT (90 percent).  
  

$$.1 \text{ OAT} + .9 \text{ RAT} = \text{MAT} \quad \text{or substituting example values} \quad .1 (60^\circ\text{F}) + .9 (75^\circ\text{F}) = 73.75^\circ\text{F}$$
4. Adjust the minimum position potentiometer knob until proper mixed air temperature as calculated above is reached. Care should be taken to insure thermometer is sensing air that is well mixed.

5. Mark correct setting on dial of minimum position potentiometer for future reference.
- D. Adjust the enthalpy control to position A,B,C,D to achieve the maximum combination of temperature and humidity acceptable for the installation as per the chart below. (The suggested setting is between A & B 70°DB @ 55 percent RH. It is further recommended to always set the control at C or above.) (Figure 5)

	Dial Setting	20% RH	50% RH	80% RH
Enthalpy Control Setting	A	78°F (26°C)	73°F (23°C)	68°F (20°C)
	B	73°F (23°C)	68°F (20°C)	63°F (17°C)
	C	68°F (20°C)	63°F (17°C)	59°F (15°C)
	D	62°F (17°C)	58°F (14°C)	53°F (12°C)

- E. Switch the thermostat fan control to automatic and position the heat cool switch to cool. Adjust the thermostat temperature to engage the first stage of cooling only (Y). This will cause the dampers to modulate to achieve mixed air temperature of 55° provided outside air enthalpy is sufficiently low. If enthalpy is too high for economizing, low enthalpy can be simulated by temporarily removing and jumping leads on terminal 2 and 3 of enthalpy control together. This will also cause the economizer damper to modulate away from minimum position (be sure to properly reconnect leads at end of checkout procedure).
- F. Readjust temperature on the thermostat to engage the second stage of cooling (Y2). The damper motor should return to previously set minimum position. Compressor motor should start.
- G. Switch thermostat to off fan and off heat/cool positions to de-energize unit. Economizer damper should return to full closed (100 percent return air) position. Checkout is complete.
15. Replace mist eliminator.
16. Remove blank off plate or barometric fresh air damper if installed on the service access panel. Plug the (4) holes used to mount the BOP or BEAD with the plastic plugs supplied with the economizer.
17. Replace service access panel.
18. Economizer is now ready for operation.

## ECONOMIZER -- (WA Series)

### Features:

- One piece construction--easy to install with no mechanical linkage adjustment required.
- Exhaust air damper--built in with positive closed position. Provides exhaust air capability to prevent pressurization of tight buildings.
- Actuator motor--24 volt, power open, spring return with built in torque limiting switch.
- Proportioning type control--for maximum "Free Cooling" economy and comfort with up to 100% outside air.
- Moisture eliminator & prefilter--permanent, washable aluminum construction.
- Enthalpy control to monitor outdoor temperature and humidity--adjustable.
- Minimum position potentiometer--adjustable to control minimum damper blade position.
- Mixed air sensor to monitor outdoor & return air to automatically modulate damper position.

### Economizer Sequence of Operation

#### Condition A--Cool Outdoors

First stage cooling closes and powers the economizer dampers to economizer mode and the indoor blower starts. Mixed Air Sensor senses a mixture of return air and outdoor air and modulates the dampers accordingly. Compressor operation is inhibited. (See Figure 7, Page 13)

If second stage closes on the thermostat, the dampers return to the closed or minimum position setting and the compressor starts for mechanical cooling.

#### Condition B--Warm Outdoors

First stage cooling cycles the compressor and dampers remain in the mechanical cooling mode. (See Figure 8, Page 14)

### Wall Thermostats

#### For Air Conditioning With Economizer

Thermostat, Part No. 8403-021      (Honeywell T874D1934)  
Subbase, Pat No. 8404-012      (Honeywell Q674A1001)  
2 Stage Cool/2 Stage Heat

LOW AMBIENT CONTROL IS REQUIRED WITH ECONOMIZER FOR LOW TEMPERATURE COMPRESSOR OPERATION.

If unit is not equipped with low ambient control from factory, one must be installed. Order field installed low ambient kit CMA-6.

FIGURE 1  
 ECONOMIZER OPERATION FOR  
 SINGLE-COMPRESSOR UNITS

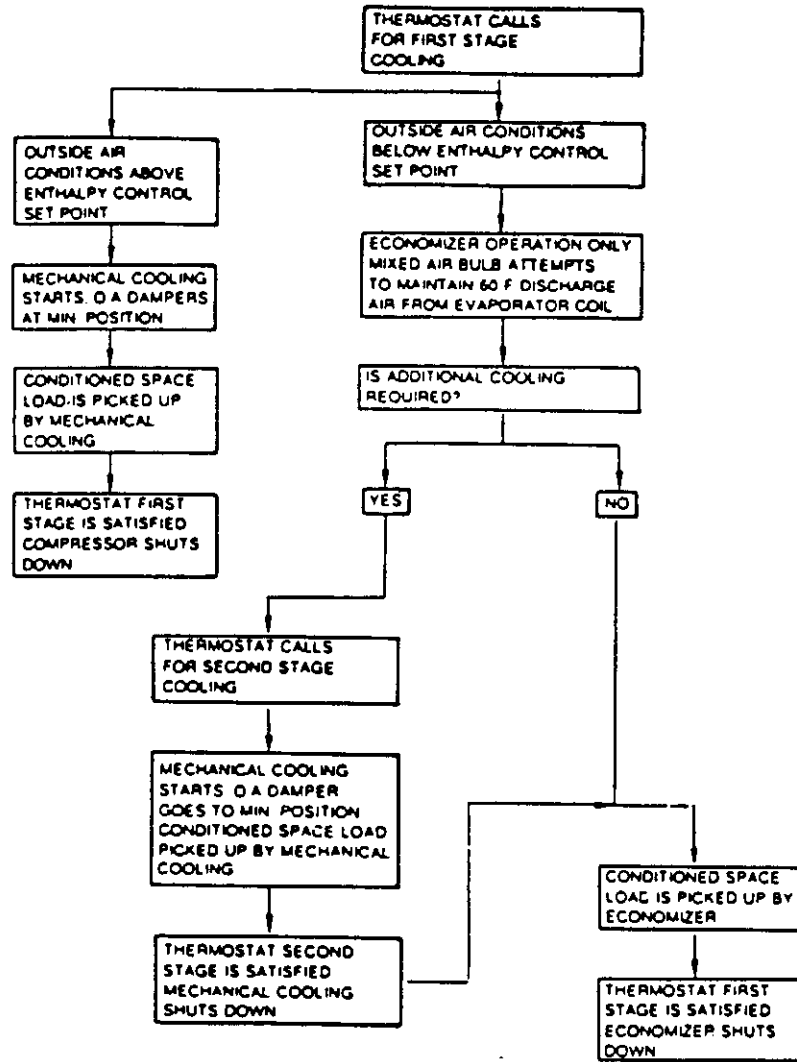

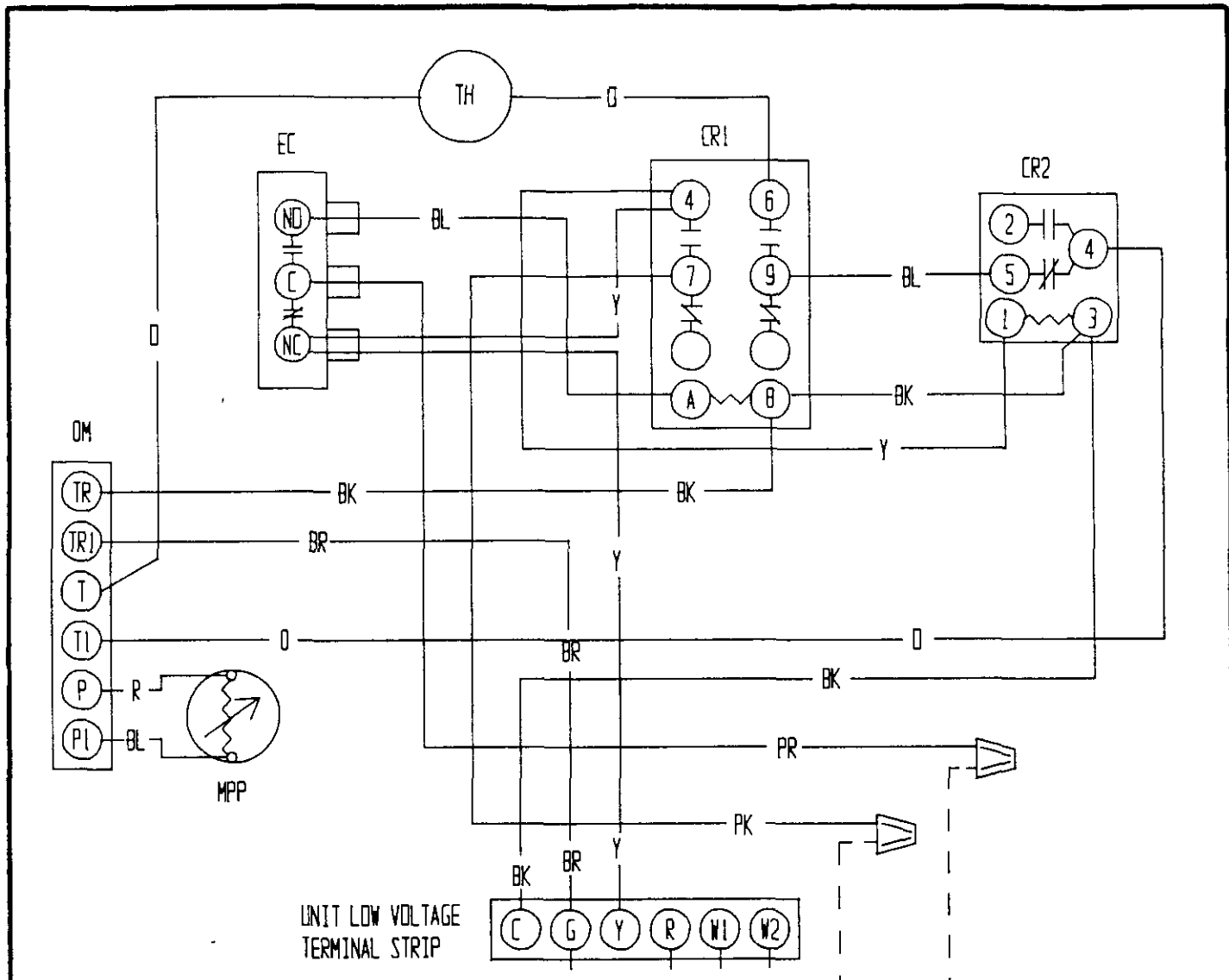

THERMOSTAT T874D1934  
 BART PART # 8403-021  
 SUBBASE G674A1001  
 BARD PART # 8404-012

## AIR CONDITIONER CONNECTION DIAGRAM

### COLOR CODE WIRE COLOR ABBREVIATION

BLACK	BK
BROWN	BR
RED	R
ORANGE	O
YELLOW	Y
GREEN	G
BLUE	BL
VIOLET(PURPLE)	V(PR)
GRAY(SLATE)	GY(S)
WHITE	W
TAN	T
PINK	PK
LAVENDER	L

### PART ABBREVIATION LIST

CR1	CONTROL RELAY 1
CR2	CONTROL RELAY 2
DM	DAMPER MOTOR
EC	ENTHALPY CONTROL
MPP	MINIMUM POSITION POT.
TH	THERMISTOR

ECONOMIZER CONTROL CIRCUIT  
LADDER DIAGRAM &  
SEQUENCE CHART

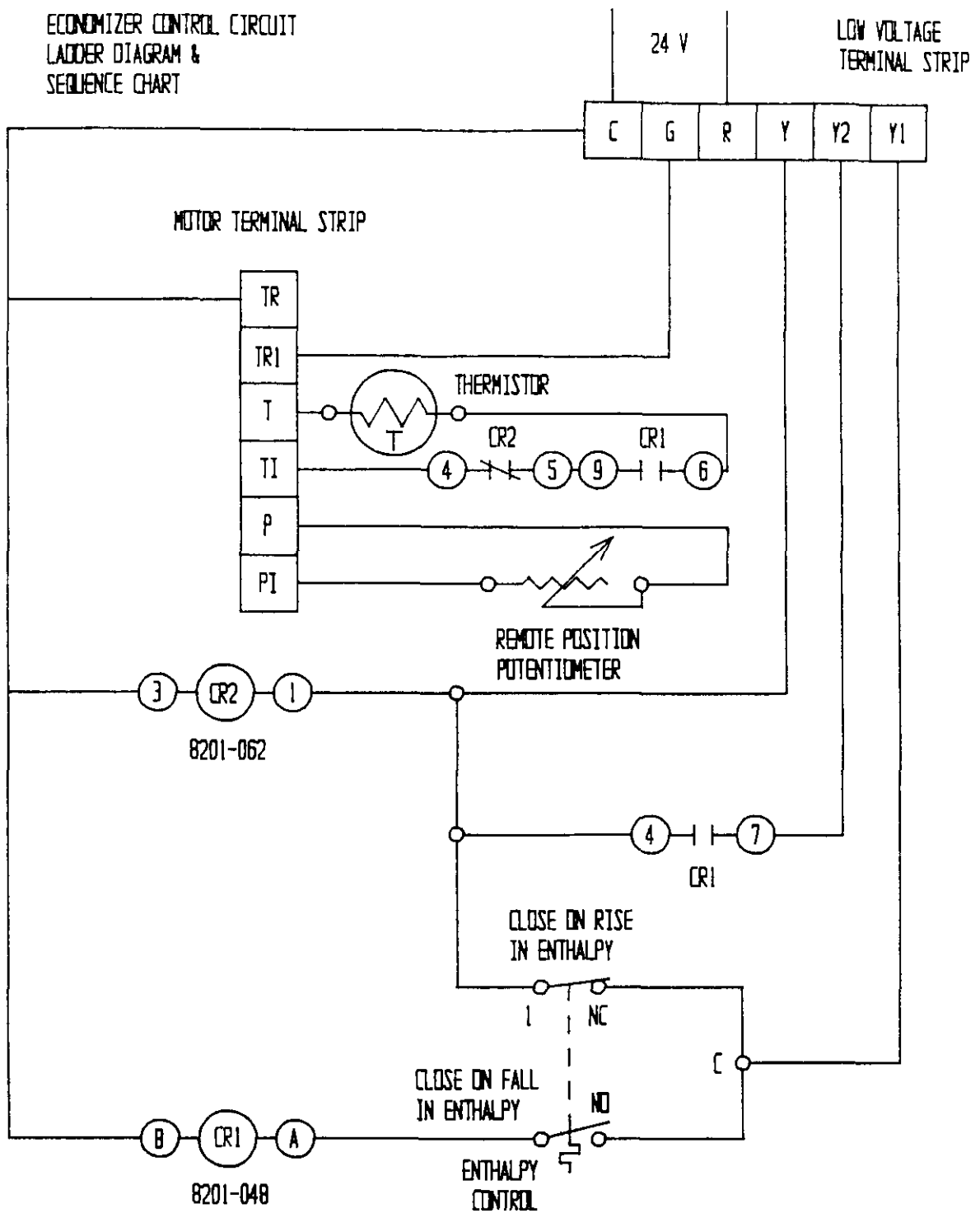

OUTDOOR CONDITIONS	HIGH TEMPERATURE HIGH ENTHALPY	HIGH TEMPERATURE LOW ENTHALPY	LOW TEMPERATURE LOW ENTHALPY	LOW TEMPERATURE HIGH ENTHALPY
ENTHALPY CONTROL (LOW) NO	OPEN	CLOSED	CLOSED	OPEN
ENTHALPY CONTROL (HIGH) NC	CLOSED	OPEN	OPEN	CLOSED
CR1	ENERGIZED	DE-ENERGIZED	DE-ENERGIZED	ENERGIZED
CR2	DE-ENERGIZED	ENERGIZED	ENERGIZED	DE-ENERGIZED
FIRST STAGE COOLING	COMPRESSOR	ECONOMIZER	ECONOMIZER	COMPRESSOR
SECOND STAGE COOLING	-----	COMPRESSOR	COMPRESSOR	-----

FIGURE 7

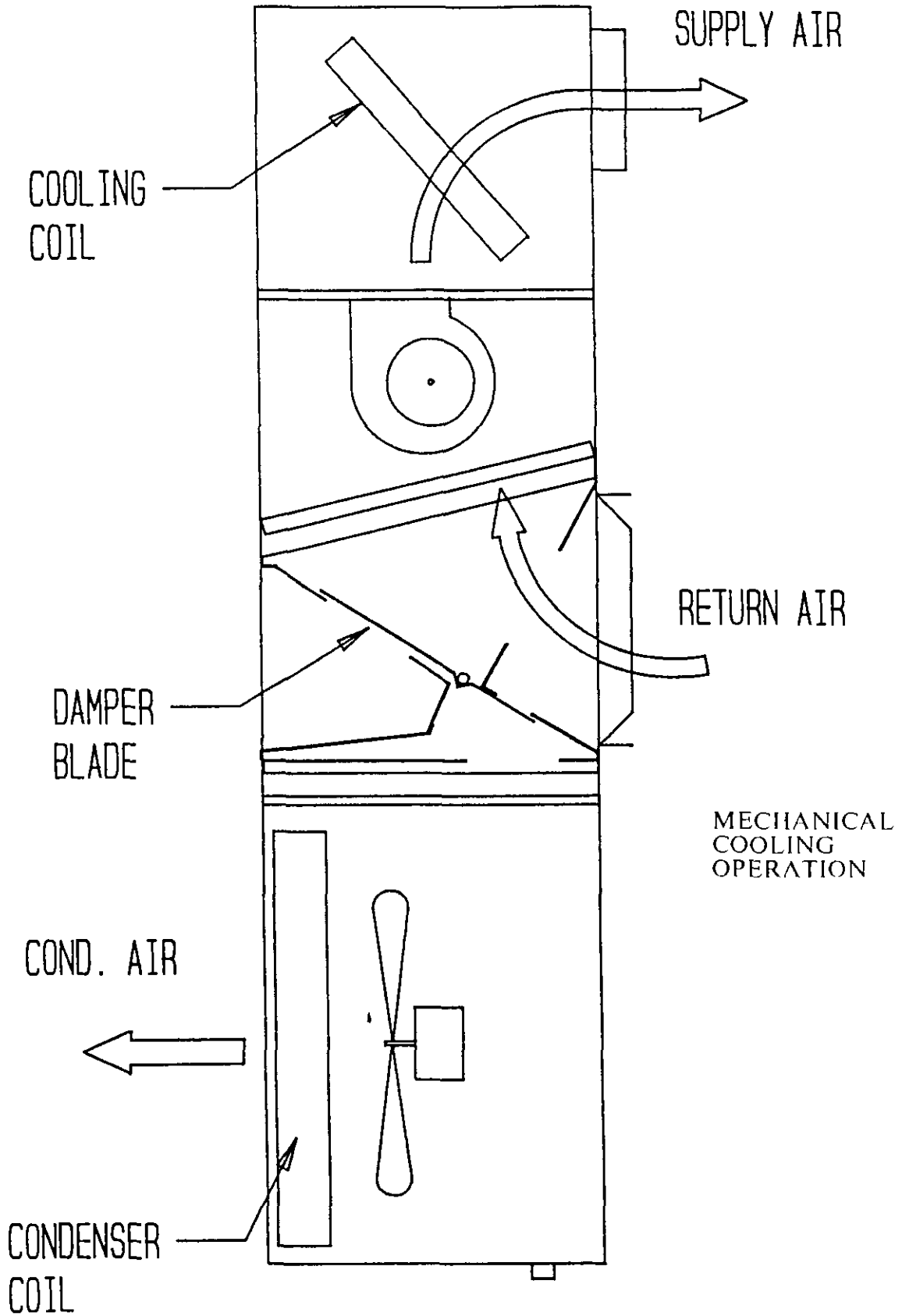

FIGURE 8

