

INSTALLATION INSTRUCTIONS HIGH ECONOMY GAS FURNACES

WARNING

READ ALL INSTRUCTIONS CAREFULLY BEFORE BEGINNING THE INSTALLATION.

THE INSTALLATION MUST COMPLY WITH THESE INSTRUCTIONS AND THE REQUIREMENTS OF ALL GOVERNING CODES AND ORDINANCES FOR THE INSTALLATION LOCATION.

IT IS THE RESPONSIBILITY OF INSTALLER TO KNOW AND UNDERSTAND ALL OF THESE REQUIREMENTS.

FAILURE TO DO SO COULD CREATE A HAZARD RESULTING IN PROPERTY DAMAGE, BODILY INJURY, OR DEATH.

MODELS:

HI-BOY

IH60D36B

IH85D48D

IH115D48B

IH115D60A

IH145D60A

LO-BOY

IL85D42D

IL115D48A

IL145D60A

C'FLOW

IC60D36A

IC85D42D

IC115D48A

IMPORTANT NOTICE

THIS FURNACE IS NOT INTENDED FOR USE AS A CONSTRUCTION HEATER.

USE OF THIS FURNACE DURING CONSTRUCTION AND FINISHING PHASES OF A STRUCTURE IS CONSIDERED AS "OPERATION IN A CORROSIVE ATMOSPHERE" AND "UNUSUAL, NEGLIGENT OR IMPROPER USE" AND AS SUCH ARE CONSIDERED EXCLUSIONS BY THE BARD MANUFACTURING COMPANY LIMITED WARRANTY.

DATE: 07-15-94

MANUAL 2100-247 REV.
SUPERSEDES REV.
FILE VOL. I, TAB 2

GETTING OTHER INFORMATION AND PUBLICATIONS

These publications can help you install the furnace. You can usually find these at your local library or purchase them directly from the publisher. Be sure to consult current edition of each standard.

National Fuel Gas Code	-ANSI Z223.1/NFPA 54
National Electrical Code	-ANSI/NFPA 70
Standard For The Installation Of Air Conditioning and Ventilating Systems	-ANSI/NFPA 90A
Standard For Warm Air Heating and Air Conditioning Systems	-ANSI/NFPA 90B
Standard For Chimneys, Fireplaces, Vents, and Solid Fuel Burning Appliances	-NFPA 211
Load Calculation For Residential Winter and Summer Air Conditioning	-ACCA Manual J
Duct Design For Residential Winter and Summer Air Conditioning and Equipment Selection	-ACCA Manual D

FOR MORE INFORMATION, CONTACT THESE PUBLISHERS

ACCA:	AIR CONDITIONING CONTRACTORS OF AMERICA 1513 16th Street NW Washington, DC 20036 Telephone: (202) 483-9370	Fax: (202) 234-4721
ANSI:	AMERICAN NATIONAL STANDARDS INSTITUTE 11 West 42nd Street, 13th Floor New York, NY 10036 Telephone: (212) 642-4900	Fax: (212) 302-1286
ASHRAE:	AMERICAN SOCIETY OF HEATING REFRIGERATING AND AIR CONDITIONING ENGINEERS, INCORPORATED 1791 Tullie Circle, N.E. Atlanta, GA 30329-2305 Telephone: (404) 636-8400	Fax: (404) 321-5478
NFPA:	NATIONAL FIRE PROTECTION ASSOCIATION Batterymarch Park P. O. Box 9101 Quincy, MA 02269-9901 Telephone: (800) 344-3555	Fax: (617) 984-7057

COPYRIGHT JULY, 1994
BARD MANUFACTURING COMPANY
BRYAN, OHIO 43506 USA

TABLE OF CONTENTS

I.	Equipment Selection	1
II.	Applications	1
III.	High Altitude Application	2
IV.	Transportation Damage	2
V.	Locating the Furnace	2
VI.	Duct Work	3
VII.	Combustion and Ventilation Air	4
	1. Sample Listing Of Contaminants To Be Avoided.	4
	2. Equipment Located in Unconfined Space	5
	3. Equipment Located in Confined Space	5
	A. All Air From Inside The Building	5
	B. All Air From Outdoors	5
	C. Louvers and Grilles	6
VIII.	Gas Supply and Piping	7
	1. General Recommendations	7
	2. Checking the Gas Piping	8
	3. Determining Gas Input--Natural Gas	9
	4. Determining Gas Input--LP Gas	9
	5. Gas Pressure Specifications	9
	6. Orifice Sizing	10
IX.	Wiring	10
	1. Electrical Power Supply	11
	2. Electrical Grounding	11
	A. Recommended Grounding Method	11
	B. Alternate Grounding Method	11
	3. Field Installed Equipment	11
X.	Flue Gas Venting	12
	1. General	12
	2. Additional Information	12
	A. Pressure Switch	12
	B. Undersized Vents	12
	C. Oversized Vents	13
	D. Other Factors Resulting In Condensation	13
	E. Types of Installations	13
	3. Replacement Furnaces	13
	A. Presale Inspection	13
	4. Masonry Chimneys	14
	5. Metallic Vertical Vent Systems	15
	6. Vent Resizing Instructions	17
	7. Venting Troubleshooting Procedures	17
	8. Suggested Vent Remedies	18
	9. New Furnace Installations (Metallic Vent Systems)	19

TABLE OF CONTENTS (continued)

XI.	Thermostat	19
XII.	Blower Operation	19
	1. Blower Speed Adjustment	19
XIII.	Filters	21
	1. Filter Locations--Removal and Replacement Procedures-- Hi-Boy Models	21
	2. Filter Locations--Counterflow Models	23
	3. Filter Locations--Lo-Boy Models	24
XIV.	Sequence of Operation	24
XV.	Maintenance Instructions	25
XVI.	Replacement Parts	25
XVII.	Service Agency Procedures	25
XVIII.	Wiring Diagrams	27
XIX.	S8600 Intermittent Pilot System Troubleshooting	30

I. EQUIPMENT SELECTION

An accurate heating load calculation must be conducted using American Society of Heating, Refrigeration and Air Conditioning Engineers (ASHRAE) or Air Conditioning Contractors of America (ACCA) manuals. DO NOT add a large safety factor above the calculated value. If the calculated heating load requirement exceeds the heating capacity rating of a given model, use only the next larger size available. Never increase by any more than absolutely necessary based upon available equipment heating capacities. Always select based upon heating capacity (output), never use input capacities.

II. APPLICATION

This is a fan-assisted Category I forced air gas furnace for indoor installation in building constructed on site. The furnace installation must conform with local building codes and ordinances or, in their absence with the National Fuel Gas Code, ANSI Z223.1-latest edition, and the National Electrical Code ANSI/NFPA 70-latest edition. It is the personal responsibility and obligation of the purchaser to contract a qualified installer to assure that installation is adequate and is in conformance with governing codes and ordinances.

***** IMPORTANT NOTICE *****

THIS FURNACE IS NOT INTENDED FOR USE AS A CONSTRUCTION HEATER.

USE OF THIS FURNACE DURING CONSTRUCTION AND FINISHING PHASES OF A STRUCTURE IS CONSIDERED AS "OPERATION IN A CORROSIVE ATMOSPHERE" AND "UNUSUAL, NEGLIGENT OR IMPROPER USE" AND AS SUCH ARE CONSIDERED EXCLUSIONS BY THE BARD MANUFACTURING COMPANY LIMITED WARRANTY.

When a furnace is used as a construction heater, it is operated under unusual and abnormal conditions that can cause condensation to occur in the furnace and/or vent system on IH - IC - IL series that will not condense under normal operation conditions when properly sized, installed and set-up for operation.

Combined with condensation problems are the many sources of chloride that are present in high concentrations during construction phases of a structure. These chloride sources are either very reduced or the vapors have left once the construction activities are completed and the structure is ready to occupy.

Many of the more common construction sources of chlorides are listed below, and they are usually present in large quantities.

Cement/Concrete Mixtures	Tile/Counter Cements
Paint	Adhesives
Stain, Varnish	Cements and Glues
Solvents	Dust Particles
Wood Preservatives	Foam Insulations
Floor Sealers	

III. HIGH ALTITUDE APPLICATIONS

Ratings of gas utilization equipment are based on sea level operation and need not be changed for operation at elevations up to 2,000 feet. For operation at elevations above 2,000 feet and, in the absence of specific recommendations from the local authority having jurisdiction, equipment ratings shall be reduced at the rate of 4 percent for each 1,000 feet above sea level before selecting appropriately sized equipment. (Ref. ANSI Z223.1 (NFPA 54), latest edition). See Table 4A.

IV. TRANSPORTATION DAMAGE

All units are packed securely in shipping container. All units should be carefully inspected upon arrival for damage. In the event of damage, the consignee should:

1. Note on delivery receipt of any damage to container.
2. Notify carrier promptly, and request an inspection.
3. In case of concealed damage, the carrier must be notified as soon as possible within 15 days after delivery.
4. Claims for any damage, apparent or concealed, should be filed with the carrier, using the following supporting documents:
 - A. Original Bill of Lading, certified copy, or indemnity bond.
 - B. Original paid freight bill of indemnity in lieu thereof.
 - C. Original invoice or certified copy thereof showing trade and other discounts or deductions.
 - D. Copy of the inspection report issued by carrier's representative at the time damage is reported to carrier.

The carrier is responsible for making prompt inspection of damage and for a thorough investigation of each claim.

V. LOCATING THE FURNACE

When selecting a location for the furnace, observe the following points:

1. The furnace should be set on a level floor. If the floor may become damp or wet at times, the furnace should be supported above the floor using a concrete base, bricks, patio blocks, etc., making sure adequate support is available for the furnace. Counterflow furnaces require use of combustible floor base if installed on combustible surface. The combustible floor base is not part of the furnace and must be ordered separately. Furnaces approved for installation on combustible flooring shall not be installed directly on carpeting, tile or other combustible material other than wood flooring.
2. The furnace should be as centralized as practical with respect to the air distribution system.
3. Provisions must be made for venting combustion products outdoors through an individual venting system.
4. Provide at least the minimum clearances specified in Table 1 for fire protection, proper operation and service access. These clearances must be permanently maintained. The combustion and ventilating air openings in front of the furnace must never be obstructed.

5. This furnace must be installed as to protect all electrical components from exposure to condensation and/or water.
6. Minimum service clearances must take precedence over fire protection clearances (minimum installation clearances).
7. All models are approved for a utility room or closet installation.
8. A gas-fired furnace installed in a residential garage must be installed so that the burners and ignition source are located not less than 18 inches above the floor, and the furnace must be located or protected to avoid physical damage by vehicles.

TABLE 1 MINIMUM CLEARANCES--INCHES

Model	Minimum Installation Clearances									Minimum Service Clearances			Minimum Ventilation Openings For Confined Spaces-- Squares Inches Of Free Area (2)
	Furnace				Plenum		(1) Duct	Vent Pipe	Floor	Front	Back	Sides	
	Front	Back	Left Side	Right Side	Top	Sides							
IR60D36B	6	0	0	4+	1	1	1	6*	C	24	0	0	100 (2 required)
IR85D48D	6	0	0	1+	1	1	1	6*	C	24	0	0	100 (2 required)
IR115D48B	6	0	0	0	1	1	1	6*	C	24	0	0	115 (2 required)
IR115D60A	6	0	0	0	1	1	1	6*	C	24	0	0	115 (2 required)
IR145D60A	6	0	0	0	1	1	1	6*	C	24	0	0	145 (2 required)
IL85D42D	6	0	0	1+	1	1	1	6*	C	24	24	18(3)	100 (2 required)
IL115D48A	6	0	0	0	1	1	1	6*	C	24	24	18(3)	115 (2 required)
IL145D60A	6	0	0	0	1	1	1	6*	C	24	24	18(3)	145 (2 required)
IC60D36A	6	0	0	4+	1	1	1	6*	NC	24	0	0	100 (2 required)
IC85D48D	6	0	0	1+	1	1	1	6*	NC	24	0	0	100 (2 required)
IC115D48A	6	0	0	0	1	1	1	6*	NC	24	0	0	115 (2 required)

(1) For the first three (3) feet from plenum. After the first three (3) feet, no clearance required.
(2) See Section VII--Combustion and Ventilation Air--for additional information.
(3) Required for access to rear of furnace to service blower compartment and air filters.
+ Clearance may be 0 inch when Type B gas vent is used.
* Clearance may be 1 inch when Type B gas vent is used.
C Floor may be combustible material.
NC Floor must be non-combustible material. Can be installed on combustible flooring only when installed on special base CFB6 or CFB7 available from factory.

VI. DUCT WORK

Inadequate Supply Air and/or Return Air Duct Systems. Short cycling because of limit control operation can be created by incorrectly designed or installed supply and/or return air duct systems.

The duct systems must be designed using ASHRAE or ACCA design manuals and the equipment cfm and external static pressure ratings to insure proper air delivery capabilities.

On replacement installations, particularly if equipment is oversized, the duct systems can easily be undersized. Modifications may be required to assure that the equipment is operating within the approved temperature rise range when under full input conditions, and that no short cycling on limit controls is occurring.

IMPORTANT

When a furnace is installed so that supply ducts carry air circulated by the furnace to areas outside the space containing the furnace, the return air must also be handled by a duct(s) sealed to the furnace casing and terminating outside the space containing the furnace. This is to prevent drawing possibly hazardous combustion products into the circulated air. See Figure 2.

When the furnace is used in connection with a cooling unit*, the furnace shall be installed parallel with or on the upstream side of the cooling unit to avoid condensation in the heating element. With a parallel flow arrangement, the dampers or other means used to control flow of air shall be adequate to prevent chilled air from entering the furnace, and if manually operated, must be equipped with means to prevent operation of either unit, unless the damper is in the full heat or cool position.

*A cooling unit is an air conditioning coil, heat pump coil or chilled water coil.

VII. COMBUSTION AND VENTILATION AIR

The furnace and furnace room must have an adequate supply of air for safe combustion and ventilation. The provisions necessary to assure an adequate air supply will vary depending upon differences in the tightness of house construction and in the location of the furnace. Methods of providing air from some typical situations are described below. Consult local codes and ordinances for requirements applicable to your specific furnace installation conditions and comply with them. In the absence of local codes and ordinances, comply with the National Fuel Gas Code, ANSI Z223.1 (NEPA 54), latest edition.

SAMPLE LISTING OF CONTAMINANTS TO BE AVOIDED

The recommended source of combustion air is to use the outdoor air supply option indicated on pages 6 and 7. However, the use of indoor air in most applications is acceptable if these guidelines are followed:

1. If the furnace is installed in a confined space, the necessary combustion air must come from the outdoors by way of attic, crawl space, air duct, or direct opening.
2. If indoor combustion air option is used, there must be no exposure to the installations or substances listed below.
3. All provisions for indoor combustion air must meet the requirements for combustion air supply indicated in the National Fuel Gas Code, Z223.1 (NEPA 54), latest edition.
4. The following types of installation will require OUTDOOR AIR for combustion, due to chemical exposures:
 - Commercial buildings
 - Buildings with indoor pools
 - Furnaces installed in laundry rooms
 - Furnaces installed in hobby or craft rooms
 - Furnaces installed near chemical storage areas

Exposure to the following substances in the combustion air supply will also require OUTDOOR AIR for combustion:

- Permanent wave solutions
- Chlorinated waxes and cleaners
- Chlorine based swimming pool chemicals
- Water softening chemicals
- De-icing salts or chemicals
- Carbon tetrachloride
- Halogen type refrigerants
- Cleaning solvents (such as perchloroethylene)
- Printing inks, paint removers, varnishes, etc.
- Hydrochloric acid
- Cements and glues
- Antistatic fabric softeners for clothes dryers
- Masonry acid washing materials

EQUIPMENT LOCATED IN UNCONFINED SPACES

In unconfined spaces in buildings, infiltration may be adequate to provide air for combustion, ventilation, and dilution of flue gases. However, in buildings of unusually tight construction, additional air shall be provided using the method described under "All Air From Outdoors" below.

An unconfined space (such as an open basement) must have a minimum volume of 50 cubic feet per 1,000 BTUH of total of all appliances in area. Adjoining rooms may be counted as one area, only if there are no doors between the rooms.

Shown to the right are the required minimum areas in square feet to qualify as an unconfined space for various total BTUH input ratings. The table is based on a room(s) with 8 foot ceiling heights.

Total BTUH Input	Unconfined Space Minimum Area In Square Feet 8' Ceiling Height
60,000	375
80,000	500
85,000	531
105,000	656
115,000	719
120,000	750
140,000	875
145,000	906
160,000	1000
200,000	1250

EQUIPMENT LOCATED IN CONFINED SPACES

A. All Air From Inside The Building

The confined space shall be provided with two permanent openings communicating directly with an additional room(s) of sufficient volume so that the combined volume of all spaces meets the criteria for an unconfined space. The total input of all gas utilization equipment installed in the combined space shall be considered in making this determination. Each opening shall have a minimum free area of 1 square inch per 1,000 Btu per hour of the total input rating of all gas utilization equipment in the confined space, but not less than 100 square inches. One opening shall be within 12 inches of the top and one within 12 inches of the bottom of the enclosure. (See Figure 1A).

B. All Air From Outdoors

The confined space shall be provided with two permanent openings, one commencing within 12 inches of the top and one commencing within 12 inches of the bottom of the enclosure. The openings shall communicate directly, or by ducts, with the outdoors or spaces (crawl or attic) that freely communicate with the outdoors.

1. When communicating with the outdoors through horizontal ducts, each opening shall have a minimum free area of 1 square inch per 2,000 Btu per hour of total input rating of all equipment in the enclosure. (See Figure 1B)
2. When communicating with the outdoors through vertical ducts, each opening shall have a minimum free area of 1 square inch per 4,000 Btu per hour of total input rating of all equipment in the enclosure. (See Figure 1C)
3. When directly communicating with the outdoors, each opening shall have a minimum free area of 1 square inch per 4,000 Btu per hour of total input rating of all equipment in the enclosure. (See Figure 1D)
4. When ducts are used, they shall be of the same cross-sectional area as the free area of the openings to which they connect. The minimum dimension of rectangular air ducts shall be not less than 3 inches. Also see chart to the right for round pipe sizes.

4,000 BTUH Per Square Inch Round Duct Size	Total BTUH Input
4-3/8	60,000
5-1/8	80,000
5-1/4	85,000
5-7/8	105,000
6-1/8	115,000
6-1/4	120,000
6-3/4	140,000
6-7/8	145,000
7-1/4	160,000
8	200,000

LOUVERS AND GRILLES

In calculating free area, consideration shall be given to the blocking effect of louvers, grilles, or screens protecting openings. Screen used shall not be smaller than 1/4 inch mesh. If the free area through a design of louver or grille is known, it should be used in calculating the size opening required to provide the free area specified. If the design and free area are not known, it may be assumed that wood louvers will have 20-25 percent free area and metal louvers and grilles will have 60-75 percent free area. Louvers and grilles shall be fixed in the open position or interlocked with the equipment so that they are opened automatically during equipment operation.

FIGURE 1

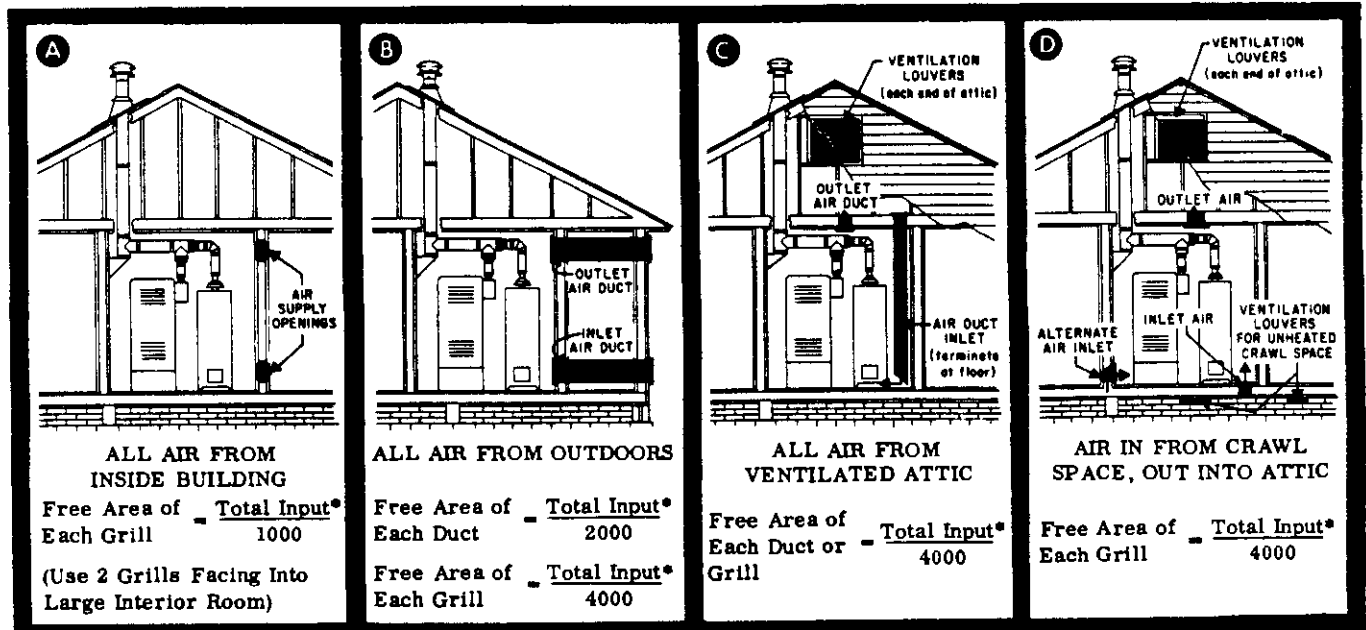

*Total Input = Total of combined appliance input ratings in BTU; (Free Area in square inches)

FIGURE 2
FURNACE LOCATED IN CONFINED SPACE

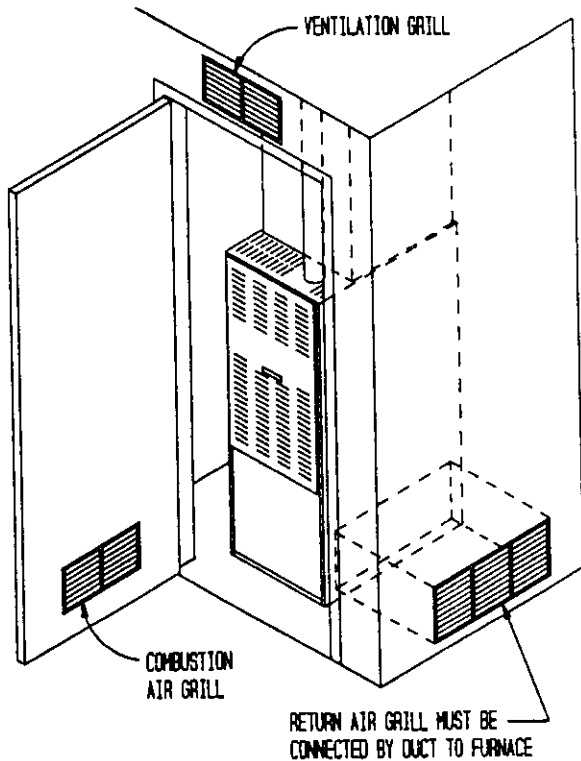
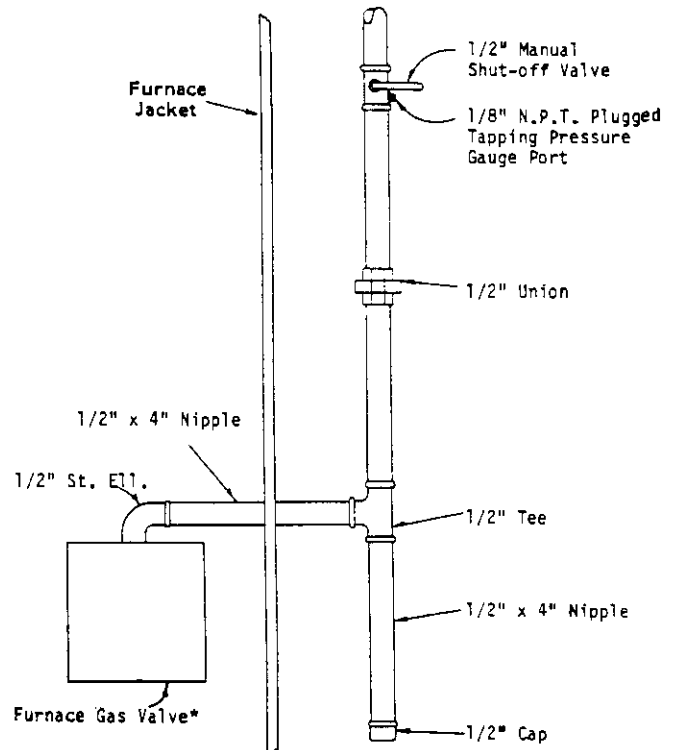

FIGURE 3
TYPICAL GAS PIPING



*Gas valve is covered to prevent dirt from entering. Remove cover only when ready to connect piping.

VIII. GAS SUPPLY AND PIPING

GENERAL RECOMMENDATIONS

1. Be sure the gas line complies with the local codes and ordinances, or in their absence with National Fuel Gas Code, ANSI Z223.1-latest edition.
2. A sediment trap or drip leg must be installed in the supply line to the furnace.
3. A ground joint union shall be installed in the gas line adjacent to and upstream from the gas valve and downstream from the manual shut off valve.
4. An 1/8" N.P.T. plugged tapping accessible for test gauge connection shall be installed immediately upstream of the gas supply connection to the furnace for the purpose of determining the supply gas pressure.
5. A manual shut-off valve shall be installed in the supply gas line external to the furnace when required by local code. See Figure 3.
6. Use steel or wrought iron pipe and fittings.
7. DO NOT thread pipe too far. Valve distortion or malfunction may result from excess pipe within the control. Use pipe joint compound resistant to the action of liquified petroleum gases on male threads only. DO NOT use Teflon tape. See Table 2 and Figure 4.

FIGURE 4

TABLE 2
LENGTH OF STANDARD PIPE THREADS (inches)

Pipe Size	Effective Length of Thread	Overall Length of Thread
3/8	3/8	9/16
1/2	1/2	3/4
3/4	1/2-9/16	13/16
1	9/16	1

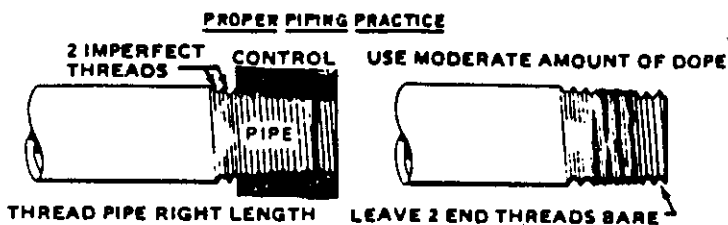

8. Refer to Table 3 for Gas Pipe Sizes for natural gas. If more than one appliance is supplied from a single line size, capacity must equal or exceed the combined input to all appliances, and the branch lines feeding the individual appliances properly sized for each input.

TABLE 3
GAS PIPE SIZES--NATURAL GAS

Length of Pipe, Ft.	Pipe Capacity--Btu Per Hour Input Pipe Size			
	1/2"	3/4"	1"	1-1/4"
10	132,000	278,000	520,000	1,050,000
20	92,000	190,000	350,000	730,000
30	73,000	152,000	285,000	590,000
40	63,000	130,000	245,000	500,000
50	56,000	115,000	215,000	440,000
60	50,000	105,000	195,000	400,000
70	46,000	96,000	180,000	370,000
80	43,000	90,000	170,000	350,000
100	38,000	79,000	150,000	305,000

CHECKING THE GAS PIPING

Before turning gas under pressure into piping, all openings from which gas can escape should be closed. Immediately after turning on gas, the system should be checked for leaks. This can be done by watching the 1/2 cubic foot test dial and allowing 5 minutes to show any movement, and by soaping each pipe connection and watching for bubbles. If a leak is found, make the necessary repairs immediately and repeat the above test. The furnace must be isolated from the gas supply piping system by closing the manual shutoff valve on the combination gas control valve during pressure testing of the gas supply piping system at pressures up to 1/2 psig. The furnace must be disconnected from supply piping and supply piping capped during any pressure testing of supply piping system at test pressures in excess of 1/2 psig.

Defective pipes or fittings should be replaced and not repaired. Never use a flame or fire in any form to locate gas leaks, use a soap solution.

After the piping and meter have been checked completely, purge the system of air. DO NOT bleed the air inside the furnace. Be sure to check and relight all the gas pilots on other appliances that may have been extinguished because of interrupted gas supply.

DETERMINING GAS INPUT--NATURAL GAS

The following is a procedure in which to measure gas input:

1. Turn off all gas appliances other than the furnace.
2. From local gas supplier, obtain the average heating value in BTU/CU FT of gas supplied to the installation site.
3. Light furnace following the lighting and operating instructions label.
4. With a stop watch, measure the amount of time, in seconds, it takes to consume two (2) cubic feet of gas.
5. Use the following formula to calculate the gas input of the furnace.

$$\text{Gas input rating in BTU/HR} = \frac{\text{BTU/CU FT} \times 7200}{\text{Time in seconds for two Cubic feet of gas flow}}$$

Example: Assume a time of 60 seconds for two cubic feet has been determined with a heating value of 1,000 BTU/CU FT.

$$\text{Gas input rating} = \frac{1000 \times 7200}{60}$$

$$\text{Gas input rating} = 120,000 \text{ BTU/HR}$$

6. If the input rate is not within two percent of the rated input, it may be achieved by adjusting the manifold pressure. If the specified input cannot be obtained, the furnace must be reorificed.

CAUTION: For operation at elevations above 2,000, the installer must comply with the "High Altitude Applications" section on Page 2.

DETERMINING GAS INPUT--LP GAS

The pressure regulator on the storage tank must be adjusted to maintain a 11.0" - 13.0" W.C. line supply pressure to the furnace, and the manifold pressure set at 10.0" W.C. on the exit side of the furnace gas valve. This pressure will result in correct input when the burners are orificed properly.

GAS PRESSURE SPECIFICATIONS

This furnace is equipped with fixed orifices for rated input with the following gas pressures:

TABLE 4

	Supply		
	Minimum	Maximum	Manifold
Natural @ 1,000 BTU/CU FT	4.5" WC	11.0" WC	3.5" WC
LP @ 2,500 BTU/CF FT	11.0" WC	13.0" WC	10.0" WC

The supply pressure may be measured by attaching a water column gauge to a pressure tap adjacent to and up stream from the gas valve. The manifold pressure may be measured by removing the small pipe plug located in the top of the main burner manifold, and inserting a pressure tap. Attach water column gauge to tap and ignite main burner. Small variations in the gas pressure may be made, not to exceed + 0.1" W.C., to achieve rated manifold pressure. This may be achieved by turning the gas valve regulator adjusting screw clockwise to increase pressure or counter-clockwise to decrease pressure. Major changes in flow rate must be made by changing the size of the main burner orifices.

Underfire Conditions. Underfire conditions (not setting up furnace installation for full input operation) can also cause condensation and corrosion problems. Natural gas models are to be operated at 3.5 inches W.C. manifold pressure with standard factory supplied orifice sizes. Models converted to L.P. gas are to be operated at 10.0 inch W.C. using the designated orifices from the approved L.P. conversion kit.

It is not acceptable to either reduce manifold pressure or to reduce orifice size to compensate for oversized equipment. It is mandatory that manifold pressure be checked at time of installation/start-up of the furnace. Adjustments if necessary must be made to achieve correct manifold pressures as stated above and also on the rating plate on the furnace.

ORIFICE SIZING

These furnaces are shipped with fixed gas orifices for use with National Gas and sized for 1000 btu/cubic foot gas. Make sure actual furnace gas input does not exceed furnace rating plate input. You may need to change orifices to get correct gas input. Whether you do or not depends on furnace input, your gas heat value at standard conditions and elevation. Consult your local gas supplier for gas heat value and any special derating requirements. Table 4A below gives normal orifice specifications based upon standard conditions as shown.

For propane (LP) gas operation, the furnace must be converted using authorized LP Kit sold separately.

TABLE 4A
EQUIVALENT ORIFICE SIZES AT HIGH ALTITUDE
(INCLUDES 4% INPUT REDUCTION FOR EACH 1,000 FEET)

Orifice Size Chart--All IH-IC-IL Series Models										
Fuel Gas Type	Gas Heat Value Btu/Cu. Ft. *	0 to 2000 Feet	2001 to 3000 Feet	3001 to 4000 Feet	4001 to 5000 Feet	5001 to 6000 Feet	6001 to 7000 Feet	7001 to 8000 Feet	8001 to 9000 Feet	9001 to 10,000 Feet
Natural	800 - 849	#33	#35	2.75mm	#36	#37	2.60mm	2.55mm	2.50mm	2.45mm
	850 - 899	#35	2.70mm	2.65mm	2.60mm	#38	#39	#40	#41	#42
	900 - 949	#36	2.60mm	#38	#39	#40	#41	2.40mm	2.35mm	2.30mm
	950 - 999	#37	#39	#40	#40	#41	#42	2.35mm	2.30mm	2.25mm
	1000 - 1049**	#38	#40	#41	2.40mm	#42	2.30mm	#43	2.25mm	#44
	1050 - 1100	2.50mm	2.40mm	#42	2.35mm	2.30mm	#43	2.25mm	#44	2.15mm
Propane (LP)	2500***	1.55mm	1.50mm	1.50mm	1.45mm	1.45mm	1.40mm	1.40mm	1.35mm	1.30mm

* At standard conditions: Sea level pressure and 60°F temperature.

** Standard factory supplied orifice size.

*** BTU/cu. ft. at 60°F temperature.

IX. WIRING

IMPORTANT

For your personal safety, turn off electric power at service entrance panel before making any electrical connections.

All electrical work must conform with local codes and ordinances or, in their absence, with the National Electrical Code, ANSI/NFPA 70-latest edition.

ELECTRICAL POWER SUPPLY

Run a separate 120 volt, AC circuit from a separate fuse or circuit breaker in the service entrance panel with an ampacity rating per table 5. Locate a shut off switch at the furnace. Make connections from this switch to the furnace junction box as shown in the furnace wiring diagram.

TABLE 5

Model	Volts/HZ/PH	Total Amps	Blower Motor		Inducer Motor		Minimum Circuit Ampacity	Maximum Time Delay Fuse or HACR Circuit Breaker
			HP	FLA	HP	FLA		
IH60D36B IC60D36A	115/60/1	7.5	1/3	6.5	1/40	1.0	15	15 amp
IH85D48D IC85D42D IL85D42D	115/60/1	10.0	1/3	9.0	1/40	1.0	15	15 amp
IH115D48B IC115D48A IL115D48A	115/60/1	11.5	1/2	10.5	1/40	1.0	15	20 amp
IH115D60A IH145D60A IL145D60A	115/60/1	13.5	3/4	12.5	1/40	1.0	17	25 amp

ELECTRICAL GROUNDING

Recommended Grounding Method

When installed, the furnaces must be electrically grounded in accordance with local codes or in the absence of local codes, with the National Electrical Code, ANSI/NFPA No. 70-latest edition. Use a #14 AWG copper wire from green screw or green ground wire on the furnace to a grounded connection in the service panel or a properly driven and electrically grounded ground rod.

Alternate Grounding Method

If the recommended grounding method is impossible, permanently ground the furnace from the ground connector to a grounded cold water pipe* using a separate, green colored, insulated conductor of appropriate size. THIS, HOWEVER, IS NOT RECOMMENDED.

*Cold water pipe must have metal continuity to electrical ground and not be interrupted by plastic, rubber or other electrically insulating connectors (including water meter or pump) without adding a jumper wire at these connections.

NOTE: DO NOT ground to a gas supply pipe. DO NOT connect to electric power supply until appliance is permanently grounded.

FIELD INSTALLED EQUIPMENT

Wiring to be done in the field between the furnace and devices not attached to the furnace, or between separate devices which are field installed and located, shall conform with the temperature limitation for Type T wire (63 degree F rise (36 degree C)) when installed in accordance with the manufacturer's instructions. Refer to wiring diagrams, pages 32 thru 34.

X. FLUE GAS VENTING

GENERAL

This furnace may be vented directly to the outside through a suitable chimney. THIS FURNACE AS SHIPPED FROM THE FACTORY IS SUITABLE FOR A DEDICATED FLUE ONLY. It is not suitable for use with PVC, CPVC, ABS type plastic pipe. With the addition of optional field-installed Common Venting Kit, it is suitable to common vent this furnace along with another gas burning appliance to a single chimney for ease of installation.

For common venting this furnace with another gas burning appliance, the addition of Common Venting Kit is required. This kit is field installed by the installing contractor following the instructions packaged with the kit. It is a very simple procedure requiring only the removal and reinsertion of two screws and the reconnection of one wire. The kits that are required are detailed below:

TABLE 6

Furnace Model	Input Rating Btu/Hour	Common Venting Kit No.
IH60D36B	58,000	8620-005
IH85D48D	86,000	8620-006
IH115D48B	115,000	8620-006
IH115D60A	115,000	8620-006
IH145D60A	145,000	8620-027
IC60D36A	58,000	8620-011
IC85D42AD	86,000	8620-011
IC115D48A	115,000	8620-011
IL85D42D	86,000	8620-006
IL115D48A	115,000	8620-006
IL145D60A	145,000	8620-005

ADDITIONAL INFORMATION

1. Pressure Switch

Short cycling conditions because of pressure switch operation can be a factor in 80+ installations. 80+ furnaces are a Category I design and can be vented individually or in conjunction with another Category I gas burning appliance. In either instance, the specific installation information must be carefully followed to prevent excessive pressure conditions in the vent which can cause short cycling conditions.

2. Undersized Vents

The high economy furnaces have a special control circuit in which the pressure switch that proves operation of the combustion air blower and adequate combustion air will also respond to an undersized or restricted vent system and shut down the furnace before the combustion characteristics go "sour" and could potentially be forced out at the burner opening.

3. Oversized Vents

With an oversized vent or massive chimney, the flue products are sometimes unable to heat the inside surface of the chimney or vent pipe to a temperature above the dew point temperature which may result in the formation of water in chimney or vent pipe which will cause rapid deterioration of the vent system. This also makes the establishment of a proper draft more difficult during the start-up of a cold furnace.

4. Other Factors Resulting In Condensation

Several additional factors may contribute to condensate formation in the vent. The physical mass of the vent is as important as size. Outside masonry chimneys and unlined interior masonry chimneys are unsatisfactory because the flue products do not contain enough heat to warm the massive brick wall of the chimney. Interior masonry chimneys are acceptable only as detailed under Masonry Chimneys on page 14.

5. Types Of Installations

The following information is broken down into two basic types of installations:

- A. Replacement furnaces using existing vent systems (page 13).
- B. New furnaces using metallic vertical vent systems (page 19).

REPLACEMENT FURNACES

Vent sizing for metallic vents should be based on the GAMA VENTING TABLES, manual 2100-171A. Other criteria for vent installations must be in accordance with the National Fuel Gas Code, ANSI Z223.1-latest edition and addenda Z223.1A-latest edition, or applicable provisions by local building codes.

Presale Inspection

The following information will describe for distributors, dealers, and installing contractors, a method for identifying an acceptable vent before the furnace is installed.

Existing vents must always be inspected before furnace installation. Most replacement dealers conduct this vent inspection and this practice is heartily endorsed. Vent inspections are doubly important when high-efficiency furnaces are installed, because of the reduced heat input to the vent. This inspection should be conducted before the sale of the furnace. Venting conditions should also be addressed before the sale by specifically stating that the quoted price either does or does not include modifications to the vent system. In any case, the inspection must be conducted before installation. This practice will reduce the possibility of call-backs to correct venting problems, and will increase customer satisfaction.

The information for replacement furnaces is broken down into five categories:

1. Masonry chimneys--page 14
2. Metallic vertical vent systems--page 15
3. Vent resizing instructions--page 17
4. Venting troubleshooting procedures--page 17
5. Suggested vent remedies--page 18

MASONRY CHIMNEYS

1. Unlined masonry chimneys are unacceptable.
2. Outside masonry chimneys (one or more sides exposed to outdoor air) are unacceptable for venting of these furnaces.
 - A. It is recommended that the chimney be utilized as a path for venting to the outside by running listed B-vent or listed flexible lining system approved for chimney relining up thru the chimney. See GAMA VENTING TABLES, manual No. 2100-171A for sizing information.
 - B. The vent system must be installed in accordance with the terms of their listings and vent manufacturer's instructions. An adapter may be required between the furnace vent outlet and the vent connector.
 - C. The vent system must be mechanically supported in the masonry chimney according to the manufacturer's instructions.
 - D. The bottom of the vent cap must be at least 6 inches above the masonry chimney.
 - E. The top of the masonry chimney must be sealed with a metal cap to prohibit cold air entry down the chimney surrounding the metal vent.
 - F. Another gas burning appliance such as a water heater may be common vented with the furnace. See GAMA VENTING TABLES, manual 2100-171A for sizing information.
3. An inside masonry chimney is not acceptable for venting the furnace only.
 - A. It is recommended that the chimney be utilized as a path for venting to the outside by running listed B-vent or listed flexible lining system approved for chimney relining up thru the chimney. See GAMA VENTING TABLES, manual No. 2100-171A for sizing information.
 - B. The vent system must be installed in accordance with the terms of their listings and vent manufacturer's instructions. An adapter may be required between the furnace vent outlet and the vent connector.
 - C. The vent system must be mechanically supported in the masonry chimney according to the manufacturer's instructions.
 - D. The bottom of the vent cap must be at least 6 inches above the masonry chimney.
 - E. The top of the masonry chimney must be sealed with a metal cap to prohibit cold air entry down the chimney surrounding the metal vent.
4. Inside lined masonry chimneys can only be used on a common vent installation with a draft hood appliance such as a water heater. The draft hood appliance cannot be equipped with a vent damper as it will block the flow of dilution air required to keep the vent primed and dry.
5. The vent connector pipe must not extend beyond the inside surface of the chimney liner.
6. Underground vent connectors or flue gas passages are unacceptable.
7. No solid fuel burning appliances are permitted to be commonly vented with these furnaces.

METALLIC VERTICAL VENT SYSTEMS

1. Sizing of the vent system for this furnace to be individually vented or common vented with another gas burning appliance, should be done using the GAMA VENTING TABLES, manual No. 2100-171A.
2. This furnace shall be connected to a factory built chimney or vent complying with a recognized standard.
3. The vent connector must be aluminum pipe and shall be no smaller than the flue outlet on the furnace. Keep the vent as short and direct as possible. Type B-vent pipe is recommended.
4. Maintain a minimum clearance of 6" (1" for B-1) to any portion of the vent connector from any adjacent combustible materials. Single wall vent connector is permitted only within the same space (room or area) as the furnace. B-1 vent is required whenever the vent is enclosed or passes through floors, walls, ceilings, roofs or furred-out spaces. Joists, studs, floors, dry wall, paneling, sheathing, rafters, roofing and other materials classified as combustible must not be closer than 1" clearance to B-1 vent.
5. Type B gas vents shall terminate above the roof surface with a listed cap or listed roof assembly in accordance with the terms of their respective listings and the vent manufacturer's instructions. Listed gas venting systems using listed vent caps 12" and smaller in size may terminate in accordance with the VENT TERMINATION TABLE. See Figure 5.
6. The vent pipe system shall be installed so as to avoid excessive turns which create unnecessary resistance to flow of vent gases.
7. Horizontal runs shall be as short and direct as possible. See GAMA VENTING TABLES, manual No. 2100-171A for details.
8. All horizontal vent pipe shall be pitched upward from the furnace at least 1/4 inch per foot.
9. All vent systems shall be adequately supported to maintain proper clearances, to prevent physical damage, and to prevent separation to joints.
10. Vents passing through an exterior combustible wall must use a ventilated wall thimble. See Figure 6.
11. Vents passing through floors or ceilings must be fire-stopped. See Figure 7 and Figure 8.
12. Horizontal portions of the vent system shall be supported to prevent sagging. Pipe strap or equivalent means should be used every 3 to 5 feet depending upon pipe joint lengths.
13. A furnace shall not be connected to a chimney flue serving a separate appliance designed to burn solid fuel.

FIGURE 5 GAS VENT TERMINATION TABLE

ROOF PITCH	MINIMUM HEIGHT
FLAT TO 7/12	1.0 FEET *
OVER 7/12 TO 8/12	1.5 FEET
OVER 8/12 TO 9/12	2.0 FEET
OVER 9/12 TO 10/12	2.5 FEET
OVER 10/12 TO 11/12	3.25 FEET
OVER 11/12 TO 12/12	4.0 FEET
OVER 12/12 TO 14/12	5.0 FEET
OVER 14/12 TO 16/12	6.0 FEET
OVER 16/12 TO 18/12	7.0 FEET
OVER 18/12 TO 20/12	7.5 FEET
OVER 20/12 TO 21/12	8.0 FEET

* THIS REQUIREMENT COVERS MOST INSTALLATIONS

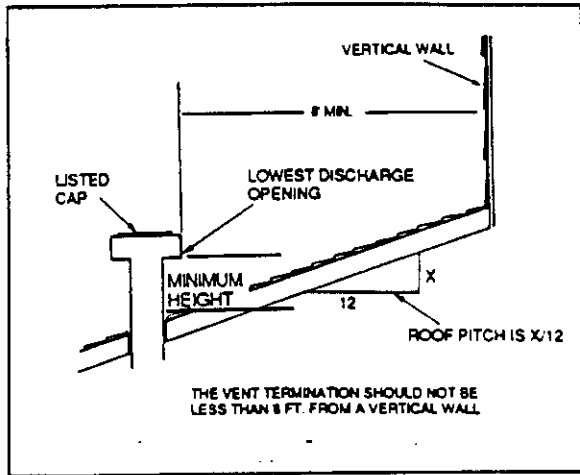

FIGURE 7 -- VENT THROUGH FLOOR

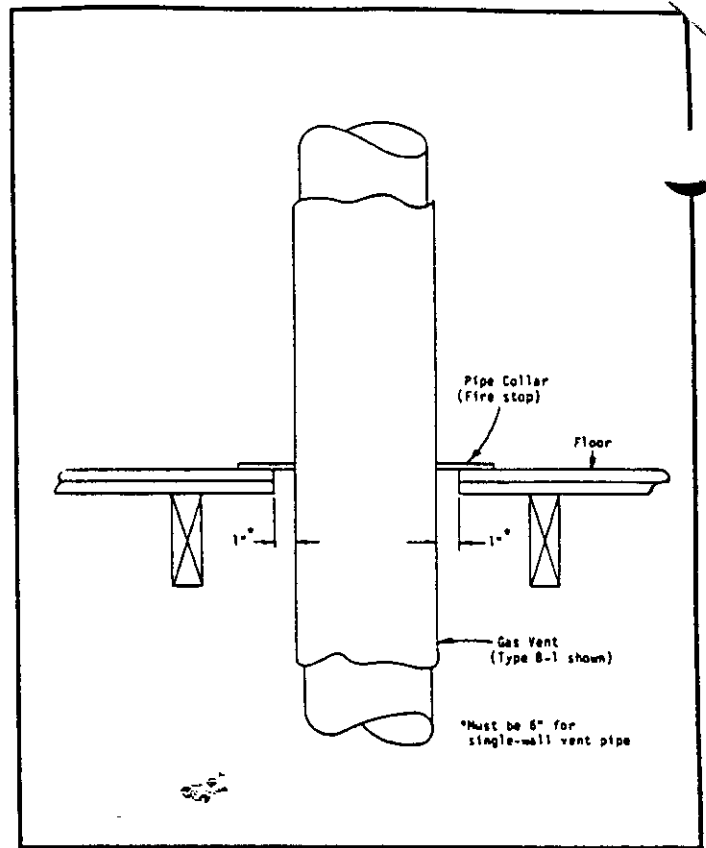

FIGURE 6 -- HORIZONTAL RUN PENETRATING COMBUSTIBLE WALL

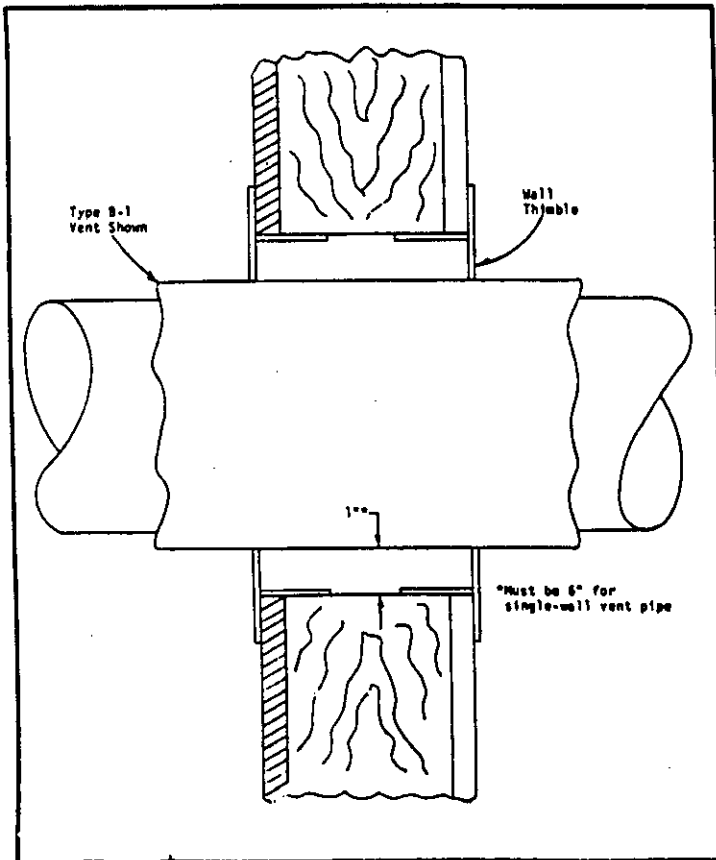
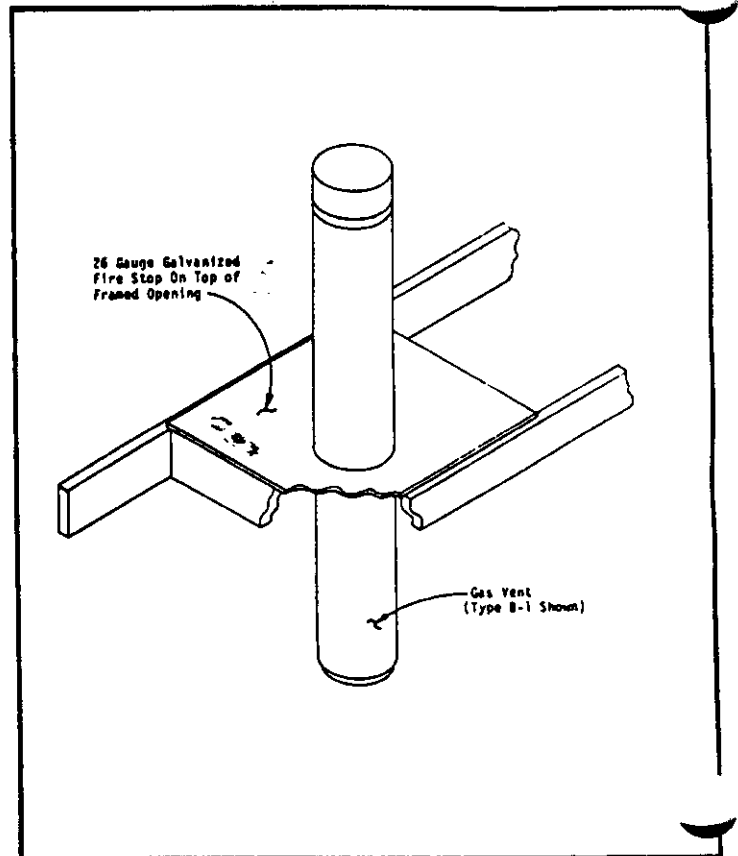

FIGURE 8 -- VENT THROUGH CEILING



VENT RESIZING INSTRUCTIONS

When an existing furnace is removed from a venting system serving other appliances, the venting system is likely to be too large to properly vent the remaining attached appliances.

The following steps shall be followed with each of the appliances remaining connected to the common venting system, placed in operation one at a time while the other appliances remaining connected to the common venting system are not in operation.

1. Seal any unused openings in the common venting system.
2. Visually inspect the venting system for proper size and horizontal pitch and determine there is no blockage or restriction, leakage, corrosion, and other deficiencies which could cause an unsafe condition.
3. Insofar as is practical, close all building doors and windows and all doors between the space in which the appliances remaining connected to the common venting system are located and other spaces of the building. Turn on clothes dryers and any appliance not connected to the common venting system. Turn on any exhaust fans, such as range hoods and bathroom exhausts, so they will operate at maximum speed. Do not operate a summer exhaust fan. Close fireplace dampers.
4. Follow the lighting instructions. Place the appliance being inspected in operation. Adjust thermostat so appliance will operate continuously.
5. Test for spillage at the draft hood relief opening after 5 minutes of main burner operation. Use the flame of a match or candle.
6. After it has been determined that each appliance remaining connected to the common venting system properly vents when tested as outlined above, return doors, windows, exhaust fans, fireplace dampers and any other gas-burning appliance to their previous conditions of use.
7. If improper venting is observed during any of the above tests, the common venting system must be corrected.

VENTING TROUBLESHOOTING PROCEDURES

TABLE 7

Symptoms	Possible Causes	How To Check And/Or Correct
Downdrafting through the furnace	Negative pressure within the structure caused by exhaust fan of device	Check for downdraft in vent where vent connects to unit with flame from a candle or a match, or smoke from a cigarette, cigar, or pipe.
	Location of vent terminal	Verify that vent termination is position with the recommended specifications stated in this manual.
	Incorrect or absent vent terminal	Verify that the vent terminal is designed for and is compatible with the venting system.
Condensation in venting system	Oversized venting system	Look for condensation in or around vent pipe joints or around flue connections at furnace. To correct this condition, design the venting system in accordance with the National Fuel Gas Code.
	Uninsulated vent installed in an unconditioned space	Check for condensation in or around vent pipe joints. Also check around the flue connecting areas on the unit. Insulate the vent in unconditioned space to prevent the above condition.
	Running vent as a liner up an existing chimney without capping off the chimney	Check to make sure the space between the vent and the inside of the chimney has been sealed. With this space being open, it may allow too much cold air in and around the vent pipe allowing the flue products to condense causing condensation back at the unit.

SUGGESTED VENT REMEDIES

The following actions are suggested to improve vent system operation:

1. For any venting problem:

- A. Set furnace to full input rate, *and
- B. adjust blower temperature rise within nameplate range.

*NOTE: Care must be taken to derate furnaces installed at elevations more than 2,000 feet above sea level. Refer to "Orifice Sizing" section of this manual.

2. Vent connectors:

- A. Avoid unnecessary elbows, bends, or restrictions in the flue system.
- B. Insulate any long single-wall metal vent connectors or replace with double-wall pipe.
- C. Avoid blowing conditioned air from the plenum or outside combustion air directly across the vent connector leaving the furnace. It may be necessary to insulate the vent connector to avoid this problem.
- D. When appliances are common vented, the common venting information on page 12 must be adhered to.

3. For excess condensate from a type B-vent:

- A. Insulate those sections of the vent exposed in unheated spaces and outdoors, or
- B. Check for oversized vent system.
- C. Provide suitable drain.

4. For recurring lockout of the positive pressure sensor and/or flame roll-out sensor.

- A. Check for adequate supply of combustion air. A very tight basement or furnace room can create air starvation which will trip the positive pressure sensor. An outdoor air supply to the furnace room or a louvered door may be required.
- B. Remove all unnecessary elbows or restrictions from the vent system, especially in the first foot of vent connector above the furnace.
- C. Check the vent system for any obstructions and correct as necessary.
- D. Insulate vent connectors or replace them with double wall pipe.
- E. If vent is undersized, replace it with a new properly sized vent.
- F. Check for an exhaust air fan or device that may create a negative pressure within the structure. If such a device is present, provisions must be made to separate the furnace room or enclosure from the rest of the structure affected by the negative pressure.

Adequate combustion air must then be introduced to the furnace room for proper operation.

NEW FURNACE INSTALLATIONS (METALLIC VENT SYSTEMS)

All new furnace installations will normally utilize metallic vent systems.

Vent sizing for metallic vents should be based upon the GAMA VENTING TABLES, manual 2100-171A. Other criteria for vent installations must be in accordance with the National Fuel Gas Code, ANSI Z223.1-latest edition and addenda Z223.1a-latest edition, or applicable provisions of local building codes.

Also see information under "Metallic Vertical Vent Systems" on page 15.

XI. THERMOSTAT

Install the thermostat in accordance with instructions packed with it. Locate the thermostat 4-1/3 feet from the floor on an inside wall away from drafts, warm air registers and floor or table lamps. Refer to furnace wiring diagrams for connections.

All 24V wall thermostats have heat anticipators to compensate the thermostat for various system controls and allow the best possible cycle rates. Some anticipators are fixed and require no adjustment. However, the majority of wall thermostats have adjustable anticipators and do require adjustment to match the current rating of the gas valve. The nominal heat anticipator setting for these furnaces is .80A.

Failure to adjust the anticipator lever to correspond to the actual current draw through the thermostat will cause severe short cycling if set too low and room temperature may never attain the thermostat set point, and if set too high, will cause room temperature to overshoot the set point.

XII. BLOWER OPERATION

All models are three or four speed direct drive and are equipped with a heating-cooling blower relay. When matched with the appropriate wall thermostat offers manual blower operation from the wall thermostat for air circulation.

Blower Speed Adjustment

CAUTION
When servicing or changing blower motor speeds, always turn off electrical power supply to the furnace to prevent possibility of electrical shock hazard.

In the event that more air or less air is desired for either the heating or cooling mode, blower speeds may be adjusted by removing the undesired motor lead from its appropriate wire and replacing it with the speed desired. All models are factory wired on low speed for heating and high speed for cooling. See Table 10 for recommended motor speeds for various size add-on air conditioning systems. Consult wiring diagram for additional information.

TABLE 10 AIRFLOW CAPACITIES AND MOTOR SPEED INFORMATION

Model	Blower Size D"xW"	Motor HP	Motor Speed	Speed Range	CFM--Inches H2O			Maximum Tons Cooling	Temperature Rise Range
					.20	.30	.50		
IL85D42D	10 x 9	1/3 Direct	4	Low	1160	1150	1100	2-1/2	35 - 65
				Med-Low	1290	1270	1210	3	
				Med-High	1440	1410	1320	3-1/2	
				High	1620	1570	1440	3-1/2 - 4	
IL115D48A	10 x 10	1/2 Direct	4	Low	1100	1090	1060	2-1/2	50 - 80
				Med-Low	1320	1310	1250	3	
				Med-High	1540	1500	1420	3-1/2	
				High	1710	1640	1540	4	
IL145D60A	11 x 10	3/4 Direct	4	Low	1250	1240	1200	3	55 - 85
				Med-Low	1370	1360	1350	3-1/2	
				Med-High	1590	1580	1600	4	
				High	2120	2080	1970	5	
IC60D36A	10 x 7	1/3 Direct	3	Low	810	780	700	1-1/2	50 - 80
				Medium	975	950	830	2	
				High	1265	1210	1070	2-1/2 - 3	
IC85D42D	10 x 9	1/3 Direct	4	Low	1230	1210	1130	2-1/2	40 - 70
				Med-Low	1330	1310	1210	3	
				Med-High	1490	1450	1325	3	
				High	1610	1550	1420	3-1/2	
IC115D48A	10 x 10	1/2 Direct	4	Low	1140	1130	1070	2-1/2	50 - 80
				Med-Low	1340	1310	1215	3	
				Med-High	1615	1570	1430	3-1/2	
				High	1860	1780	1600	4	
IH60D36B	10 x 7	1/3 Direct	3	Low	735	730	720	1-1/2	35 - 75
				Medium	950	940	905	2	
				High	1175	1155	1105	3	
IH85D48D	10 x 9	1/3 Direct	4	Low	1135	1130	1100	2-1/2	35 - 65
				Med-Low	1260	1255	1220	3	
				Med-High	1430	1425	1380	3-1/2	
				High	1625	1590	1490	4	
IH115D48B	10 x 10	1/2 Direct	4	Low	1120	1110	1080	2-1/2	50 - 80
				Med-Low	1310	1290	1230	3	
				Med-High	1580	1550	1440	3-1/2	
				High	1860	1800	1640	4	
IH115D60A	11 x 12	3/4 Direct	4	Low	1260	1240	1200	3	50 - 80
				Med-Low	1640	1616	1555	4	
				Med-High	1960	1930	1825	5	
				High	2340	2270	2150	5	
IH145D60A	11 x 12	3/4 Direct	4	Low	1335	1320	1290	3	55 - 85
				Med-Low	1530	1510	1465	3-1/2	
				Med-High	1735	1705	1635	4	
				High	2250	2175	2040	5	

CAUTION

Unused motor wires within the junction box are electrically energized when the motor is operating and must be adequately insulated. Failure to do so can cause the motor to short out or slow down which could result in the furnace overheating and/or electrical shock and/or fire hazard.

IMPORTANT

After the furnace is operating with filters installed and all cabinet panels are in place, check the temperature rise through the unit to insure it is within the range specified on the furnace rating plate. If it is not, adjust blower speed until the temperature rise is within specified range.

XIII. FILTERS

All models are shipped with filters. See Table 11 for sizes. See following information. Hi-boy models are supplied with an external filter rack which can be installed on either left or right side. The counterflow models require a bracket installation and final filter location projects into return air plenum attachment to furnace, see Figures 16 and 17. Refer to Figures 18 and 19 for Lo-Boy models which have filters internally mounted in blower compartment at rear of furnace.

TABLE 11

FILTER SIZES FOR GAS FURNACES	
Model	Size
IL85D42D Lo-Boy	(2) 9-1/2 x 20 P
IL115D48A Lo-Boy	(1) 13 x 20 P (1) 10 x 20 P
IL145D60A Lo-Boy	(2) 13 x 20 P
IH60D36B Hi-Boy	(1) 16 x 25 P
IH85D48D Hi-Boy	(1) 16 x 25 P
IH115D48B Hi-Boy	(1) 16 x 25 P
IH115D60A Hi-Boy	(1) 20 x 25 P
IH145D60A Hi-Boy	(1) 20 x 25 P
IC60D36A Counterflow	(1) 15 x 20 P
IC85D42D Counterflow	(2) 10 x 20 P
IC115D48A Counterflow	(1) 15 x 20 P (1) 10 x 20 P

P = Permanent

Filter Locations--Removal and Replacement Procedures--Hi-Boy Models

16 x 25 x 1 external filter racks are supplied as standard equipment for all IH models (20 x 25 x 1 is standard for IH115D60A and IH145D60A models). A 14 x 23 opening is to be cut into either the left or right side of the furnace depending upon installation requirements.

See Figure 13 for typical installation of a 16 x 25 x 1 filter rack centered over the 14 x 23 cutout.

Figure 14 shows a typical installation of a 20 x 25 x 1 filter rack. The same 14 x 23 cutout is required in the furnace side, and the bottom of the filter rack is aligned over the bottom of the 14 x 23 cutout. The top of the filter rack rises approximately 6 inches above the top of the cutout. The 3 inch depth of the filter rack provides ample spacing between furnace side and leaving edge of filter for the entire filter surface to be effective.

FIGURE 13

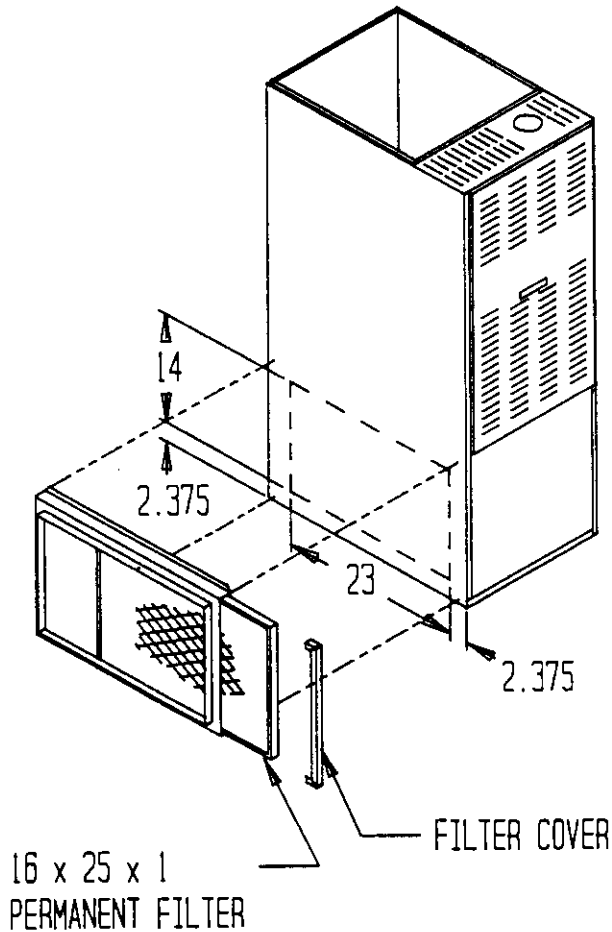
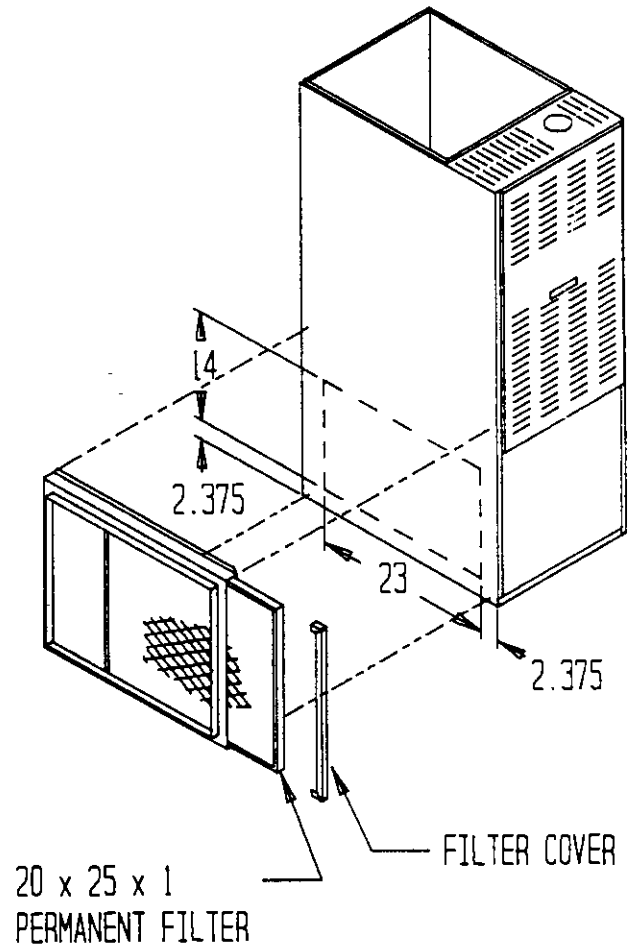

FIGURE 14



To remove filter from the filter rack (see Figures 13 and 14), remove the filter access cover and grasp the end of the filter.

This filter is the permanent high velocity type foam filter which may be washed and used over and over. DO NOT replace it with a fiberglass disposable filter of the same size.

To replace filter, reverse the above procedure.

Filter Locations--Counterflow Models

Counterflow models normally have filters installed in the return air plenum above the furnace unless a common return air/filter grille is used.

The electrical switch should be turned "off" before the front door to furnace is removed. After removing the front door, remove the left side filter door in the upper section of the furnace. Refer to Figures 16 and 17 below for proper filter locations.

FIGURE 16
IC60D36A

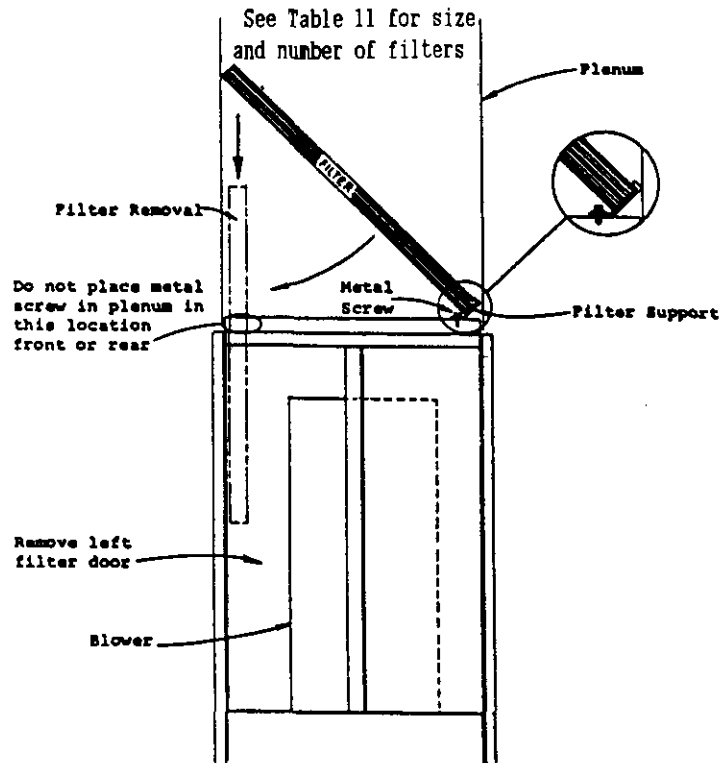

Attach filter support to furnace as shown with two sheet metal screws. The filter can be installed and removed through the left filter door.

FIGURE 17
IC85D42D, IC115D48A

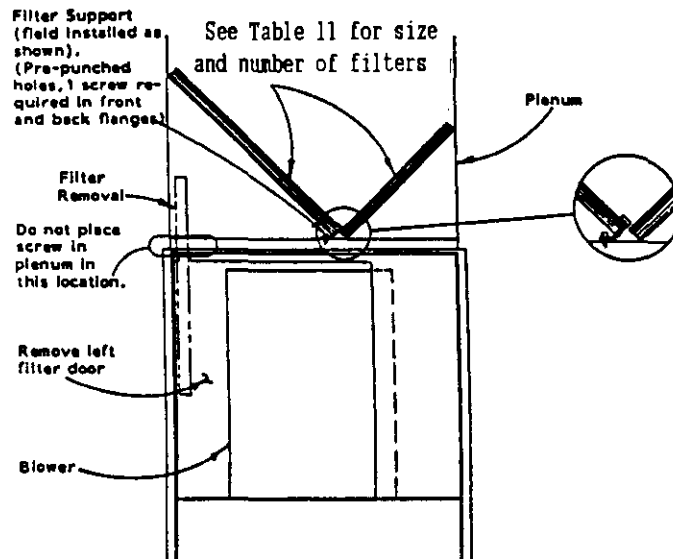

Filter Locations--Lo-Boy Models

Lo-Boy models have the filters installed in the return air cabinet section of the furnace. They are accessible from the rear of the furnace by removing the blower/filter access door. The electrical switch should be turned "off" prior to removing the access door. Refer to Figure 18 below.

FIGURE 18
IL SERIES
REAR VIEW WITH BLOWER/
FILTER ACCESS DOOR REMOVED

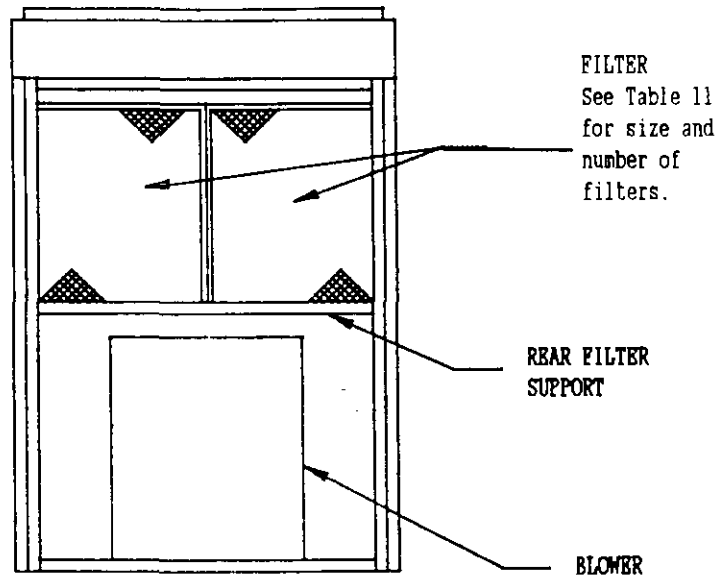

XIV. SEQUENCE OF OPERATION

On a call for heat from the thermostat the DPST relay coil is energized through the normally closed contact of the air proving pressure switch. When the relay coil is energized, the relay contacts close which simultaneously energizes the induced draft blower and locks in the relay coil. Once sufficient draft is established, the ignition module will be energized through the normally open contact of the pressure switch. The pilot ignition electrode will begin to spark and pilot valve will be energized allowing pilot gas flow. Upon establishment of pilot burner flame, adequate flame for burner ignition is proved to control module at which point main gas valve is energized and spark is discontinued.

This unit is equipped with a flame rollout switch which is wired in series with the control circuit. This is a manual reset switch and is used for the purpose of preventing possible fire hazard in the event of a system malfunction. If this switch has opened the control circuit, there could be a possible system malfunction. Some of the conditions that might cause a rollout to occur are blockage or sooting of primary heat exchanger, over-firing of furnace due to improper main burner orifices or incorrect manifold pressure, insufficient combustion air, or installation deficiencies with respect to return air duct design or sizing.

Once the problem has been resolved, reset the switch by pressing down on the black button on top of the switch.

XV. MAINTENANCE INSTRUCTIONS

The furnace and its vent system should be inspected annually by a qualified service agency, generally prior to the heating season.

NOTE: Prior to the start of any of the following maintenance procedures shut off all power to the unit .

Routine maintenance procedures are the responsibility of the owner and are contained in the Owner's Manual. These are briefly outlined below:

1. Air Filters . Check the condition on at least a monthly basis when the furnace is in use or replace whenever it is necessary.
2. Lubrication Requirements . Direct drive motors are permanently lubricated, no maintenance required. The induced draft blower motor should be oiled every heating season with 3 - 4 drops of SAE20 motor oil at both oiling locations on the motor.
3. Check Temperature Rise . Adjust blower speed if necessary to obtain a temperature rise within the range specified on the furnace rating plate.
4. Basic Examination of Furnace . Visual inspection of pilot flame and the main burners. Also inspection of the burner compartment and the vent system for sooting and scaling.
5. Periodic Inspection of the Vent System . Visual inspection of the vent system from the furnace to the chimney for any leaking or defective parts.

XVI. REPLACEMENT PARTS

Replacement parts for the gas furnaces are available through local distributors.

Parts list covering all of the normally serviceable items are listed in the Replacement Parts Manual supplied with this furnace. When ordering parts or making inquiries pertaining to any of the furnaces covered by these instructions, it is very important to always supply the COMPLETE model number and serial number of the furnace. This is necessary to assure that the correct parts (or approved alternate parts) are issued to the service agency.

The replacement parts manual numbers are as follows:

IH Series Hi-Boy -- 2110-853
IC Series Counterflow -- 2110-854
IL Series Lo-Boy -- 2110-855

XVII. SERVICE AGENCY PROCEDURES | IMPORTANT: QUALIFIED TECHNICIANS ONLY |

1. The intermittent pilot lights only when the thermostat calls for heat and the main burner lights within a few seconds thereafter. It is recommended that any observation of pilot or main burner operation be done only with the burner compartment door in place and viewing through the combustion air slots. See Figure 19.

The pilot flame can be adjusted by removing the pilot adjustment cover screw. Turn inner adjustment screw clockwise to decrease and counterclockwise to increase pilot flame. Be sure to replace cover screw after adjustment to prevent possible gas leakage. See Figure 20.

FIGURE 19
INTERMITTENT PILOT

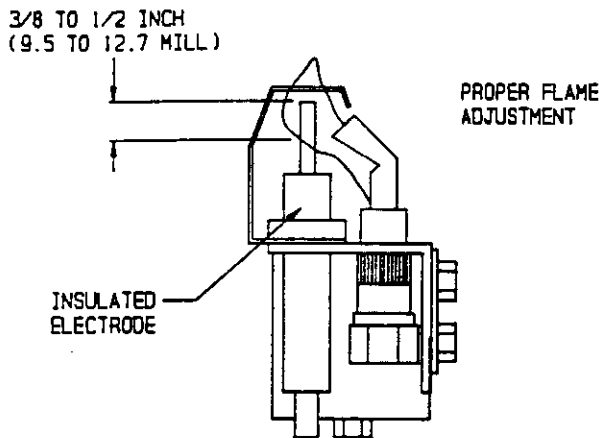
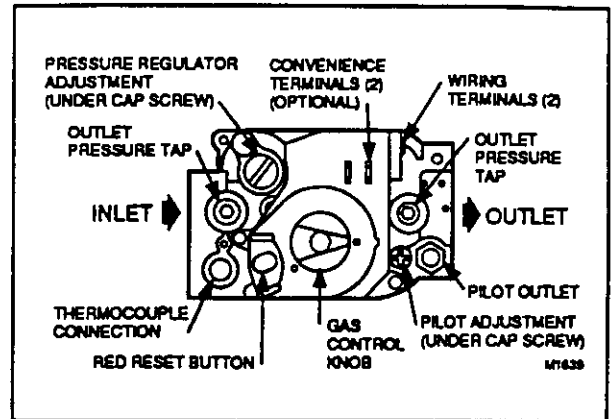

FIGURE 20
TOP VIEW OF GAS CONTROL



2. Observe the main burners in operation, viewing through the combustion air slots. The flame should be mostly "blue" with possibly a little orange at the tips of the flames. The flames should be in the center of the heat exchanger compartments and not impinging on the heat exchanger surfaces themselves.

The inner cone of the flame as shown below should be approximately 1 inch to 1-1/4 inches tall from the burner ports when natural gas is used. When LP gas is used, the inner cones should be approximately 1/2 inch tall from the burner ports. If no primary air adjustment has been made after the furnace has been converted for use with LP gas, the inner cones may be lying flat on the burner ports. This condition can be corrected by decreasing the amount of primary air in the burners. Slowly close down the primary air shutters at the end of each burner until the desired inner cone height is obtained. Be sure to tighten all the air shutter set screws once the adjustment has been made.

Observe the fire until the blower starts (there is a normal delay period until the heat exchanger warms up). There should be no change in the size or shape of the flame. If there is any wavering or blowing of the flame on the blower start-up, it is an indication of a possible leak in the heat exchanger.

The air shutters are factory adjusted completely open for use with natural gas. If flashback occurs, the air shutters may be closed slightly to prevent the flashback. If converted to LP gas, the air shutters must be adjusted as specified above.

FIGURE 21

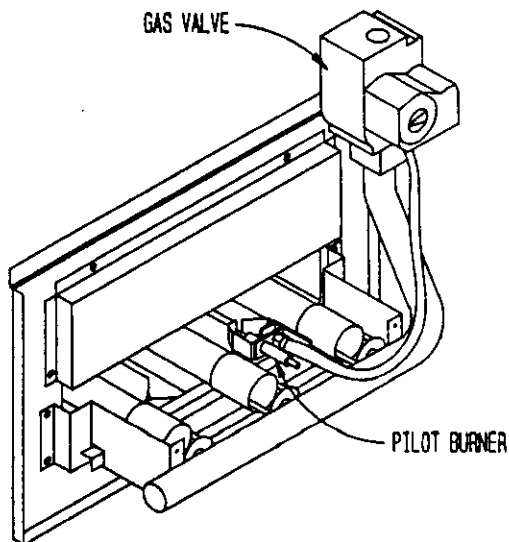
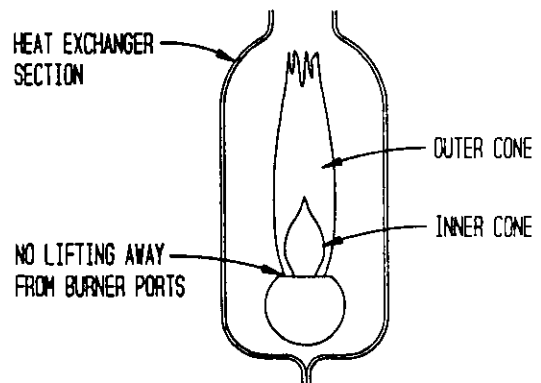
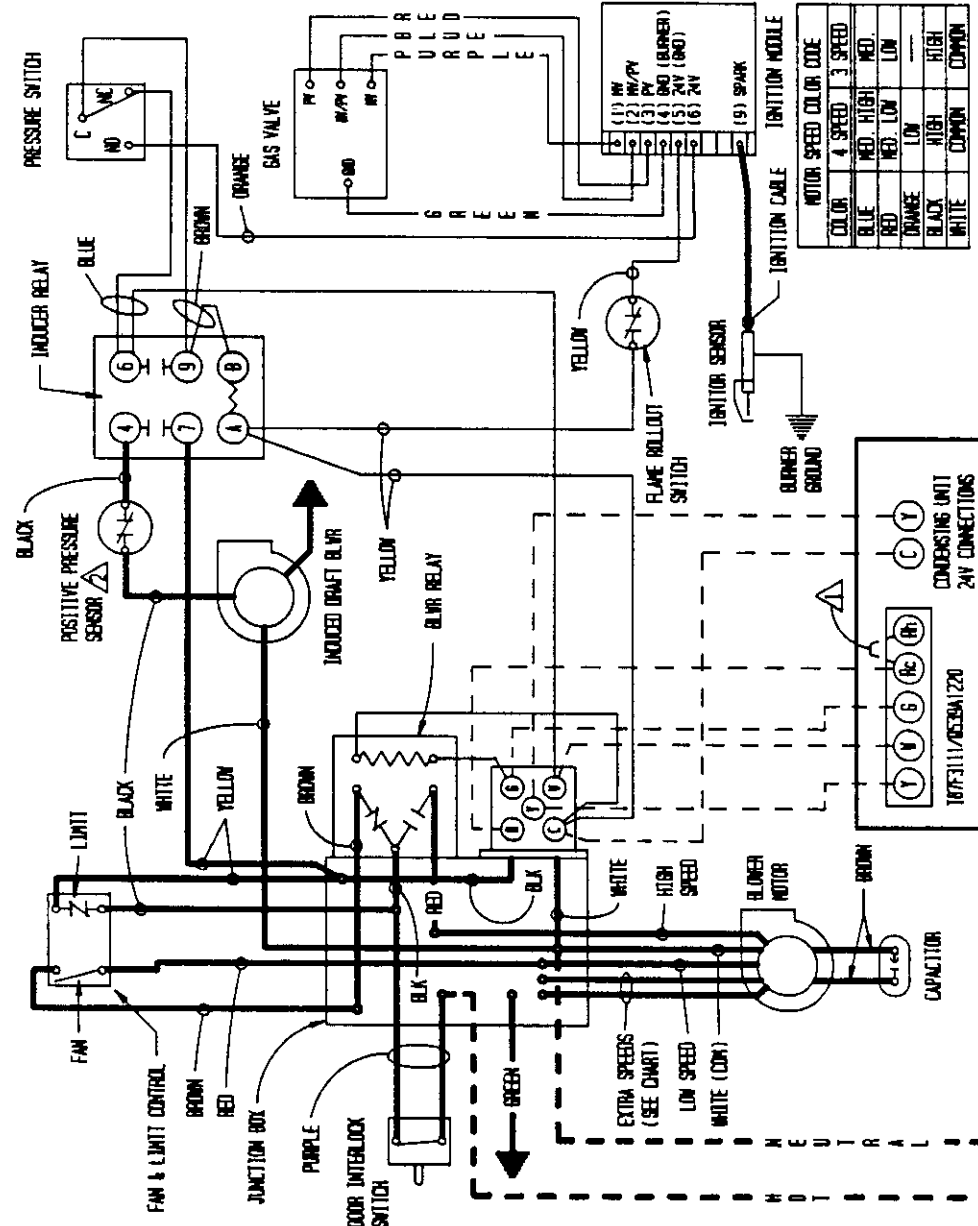

FIGURE 22



CONNECTION DIAGRAM DANGER: ELECTRICAL SHOCK HAZARD. DISCONNECT POWER BEFORE SERVICING.



MOTOR SPEED COLOR CODE	
COLOR	SPEED
BLUE	4
RED	3
ORANGE	2
BLACK	1
WHITE	0
	COMMON

USE COPPER CONDUCTORS ONLY

LOW VOLTAGE WIRING
HIGH VOLTAGE WIRING

FACTORY FIELD WIRING

LADDER DIAGRAM

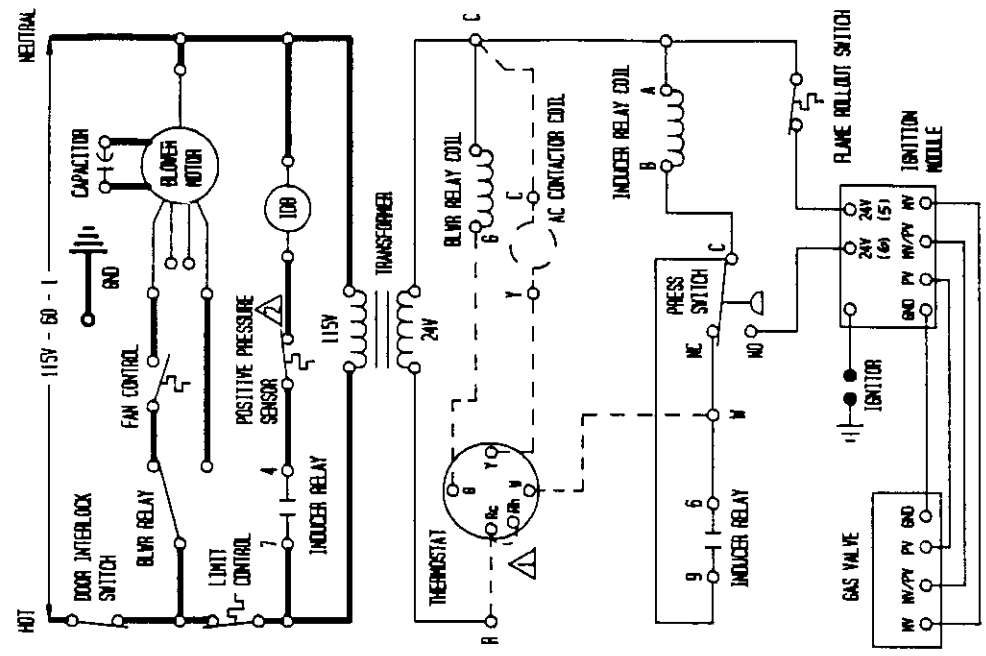

IF ANY OF THE ORIGINAL WIRE AS SUPPLIED WITH THE APPLIANCE MUST BE REPLACED, IT MUST BE REPLACED WITH WIRING MATERIAL HAVING A TEMPERATURE RATING OF AT LEAST 105°C. EXCEPT THE IGNITION CABLE WHICH IS 250°C. HIGH VOLTAGE CABLE.

1H-SERIES UPFLOW GAS FURNACE

4046-118 A

△ JUMPER R2-R4 REQUIRED ON 0528A1220.
△ FIELD INSTALLED. OPTIONAL POSITIVE PRESSURE SENSOR REQUIRED ONLY FOR COMMON VENTING INSTALLATIONS.

115-60-1

LADDER DIAGRAM

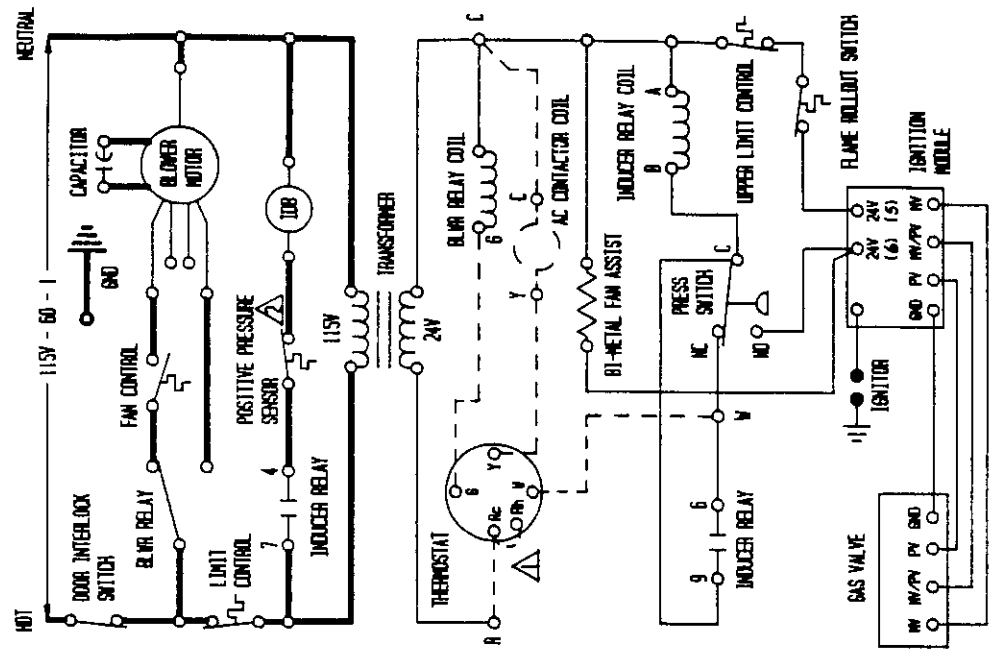

IF ANY OF THE ORIGINAL WIRE AS SUPPLIED WITH THE APPLIANCE MUST BE REPLACED, IT MUST BE REPLACED WITH WIRING MATERIAL HAVING A TEMPERATURE RATING OF AT LEAST 105°C. EXCEPT THE IGNITION CABLE WHICH IS 250°C. HIGH VOLTAGE CABLE.

IC-SERIES COUNTERFLOW GAS FURNACE

4046-119

CONNECTION DIAGRAM

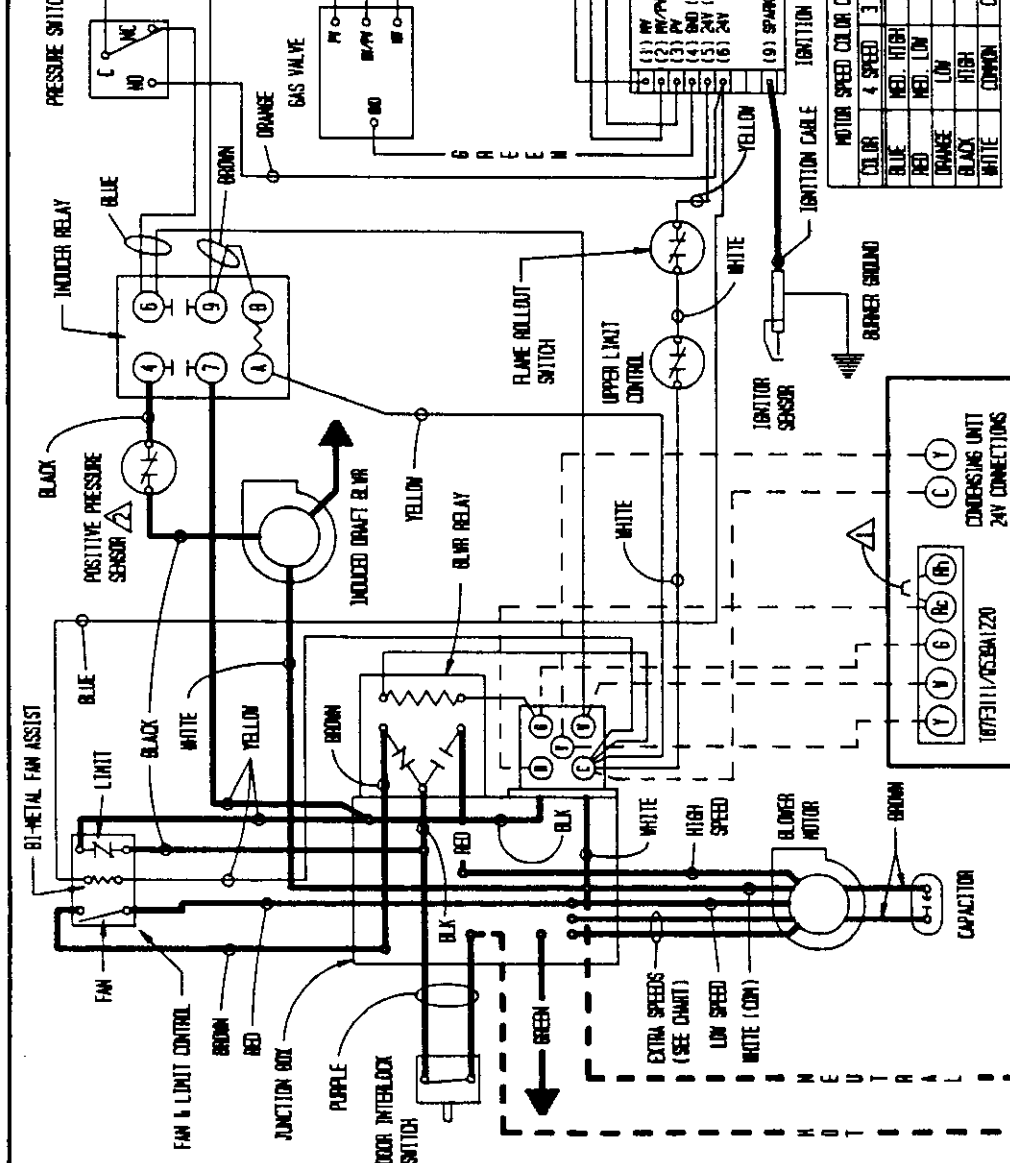

USE COPPER CONDUCTORS ONLY

LOW VOLTAGE
HIGH VOLTAGE

DANGER: ELECTRICAL SHOCK HAZARD. DISCONNECT POWER BEFORE SERVICING.

JUMPER R2-R4 REQUIRED ON 653M1220.
FIELD INSTALLED, OPTIONAL POSITIVE PRESSURE SENSOR REQUIRED ONLY FOR COMMON VENTING INSTALLATIONS.

CONDENSING UNIT 24V CONNECTIONS
107F311/653M1220

115-60-1

CONNECTION DIAGRAM DANGER: ELECTRICAL SHOCK HAZARD. DISCONNECT POWER BEFORE SERVICING.

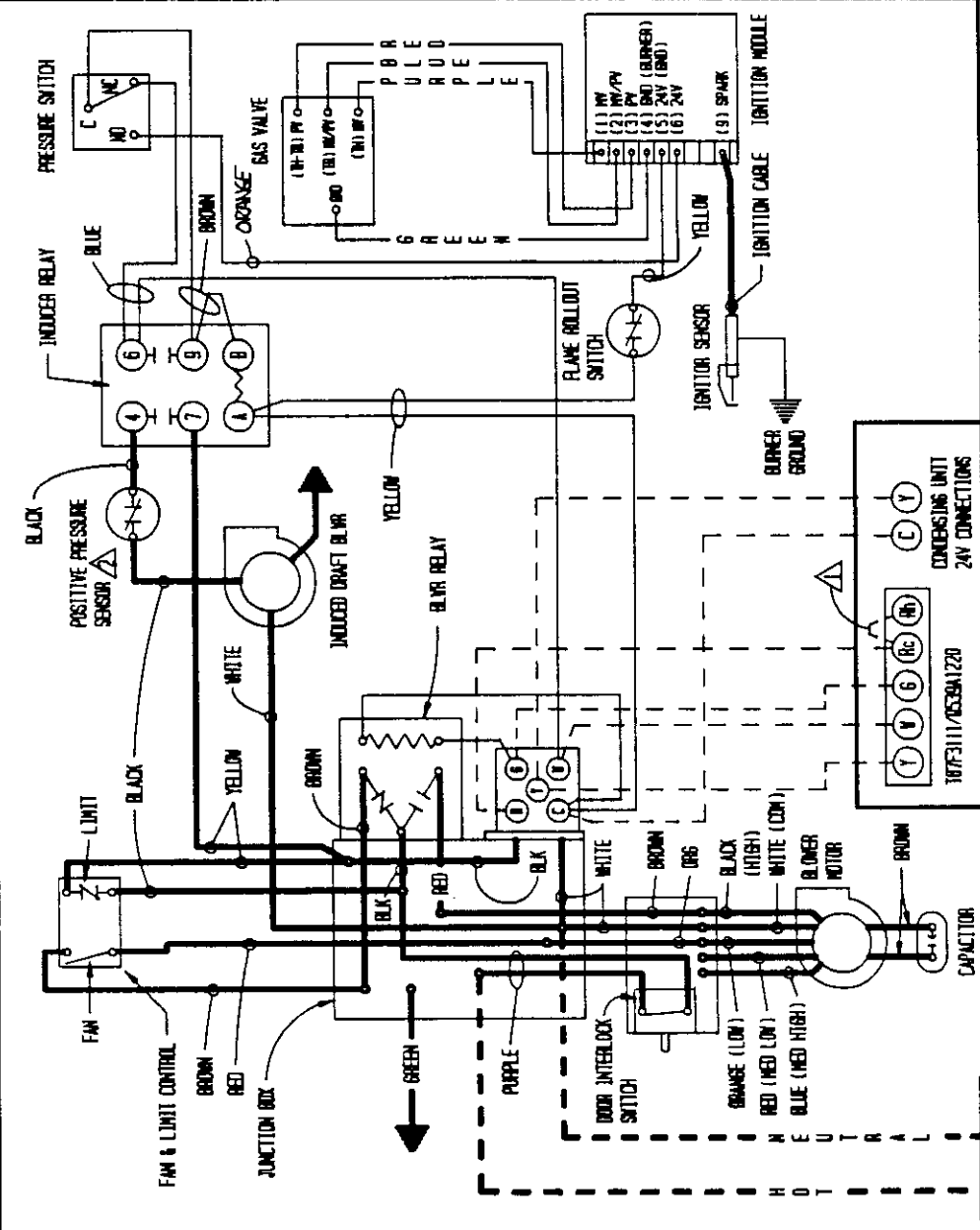

▲ JUMPER R₁-R₂ REQUIRED ON 0538A120.
 ▲ FIELD INSTALLED. OPTIONAL POSITIVE PRESSURE SENSOR REQUIRED ONLY FOR COPPER VENTING INSTALLATIONS.
 USE COPPER CONDUCTORS ONLY
 FACTORY WIRING ————
 FIELD WIRING - - - -
 LOW VOLTAGE
 HIGH VOLTAGE

LADDER DIAGRAM

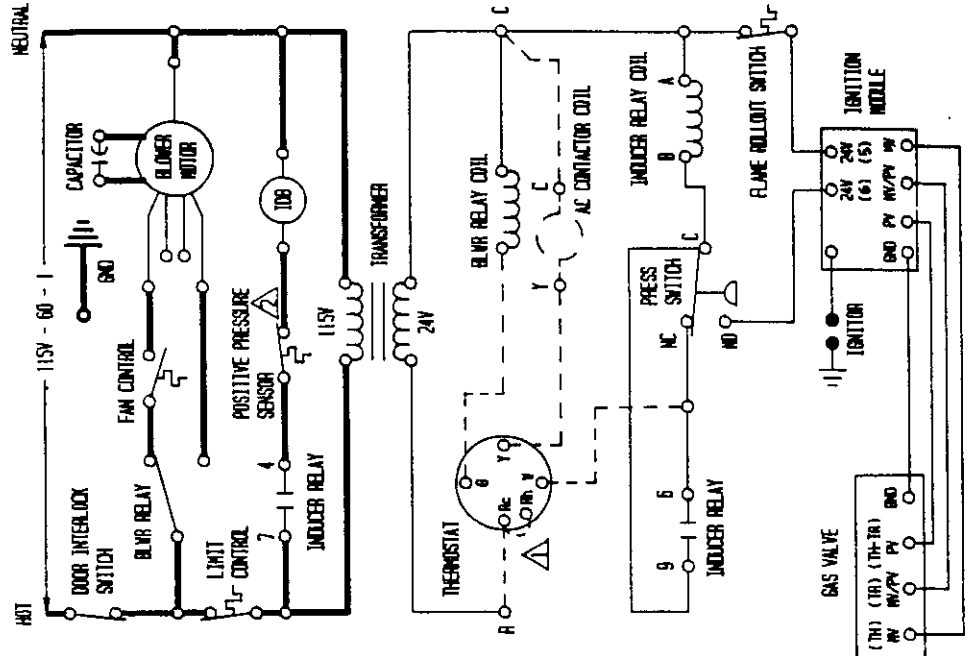

IF ANY OF THE ORIGINAL WIRE AS SUPPLIED WITH THE APPLIANCE MUST BE REPLACED. IT MUST BE REPLACED WITH WIRING MATERIAL HAVING A TEMPERATURE RATING OF AT LEAST 105°C. EXCEPT THE IGNITION CABLE WHICH IS 250°C. HIGH VOLTAGE CABLE.

IL-SERIES LG-BOY GAS FURNACE

4046-120 B

XVIII. S8600 INTERMITTENT PILOT SYSTEM TROUBLESHOOTING

