

**INSTALLATION
INSTRUCTIONS**

**WATER SOURCE
HEAT PUMP**

**MODELS: WPV48D
WPV60D**

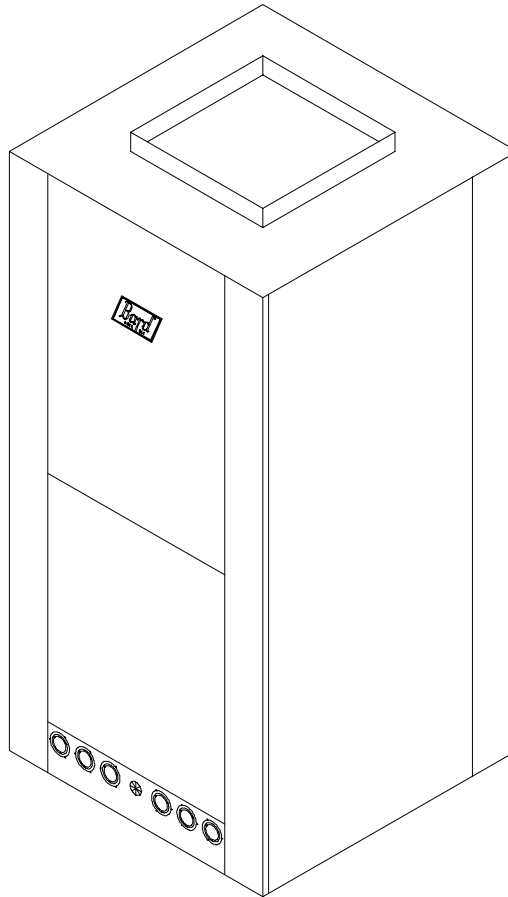

MIS-658

**Earth Loop Fluid
Temperatures 25° - 110°
Ground Water Temperatures 45° - 75°**



BARD MANUFACTURING COMPANY
Bryan, Ohio 43506
Since 1914...Moving ahead, just as planned.

Manual: 2100-250H
Supersedes: 2100-250G
File: Volume I, Tab 8
Date: 04-01-02

CONTENTS

Application and Location

General	2
Shipping Damage	2
Application	2
Location	2
Ductwork	2
Filter	3
Condensate Drain	3
Piping Access to the Unit	3

Wiring

Main Power	4
Thermostat Low Voltage Wiring	4

Accessories

Add-on DPM26A Pump Module Kit	6
General	6
Installation	6

Closed Loop (Earth Coupled Ground Loop Applications)

Circulation System Design	7
Heat Pump Connections Without Pump Kit	9
Piping Connections	9
System Start Up Procedure	12

Open Loop (Well System Application)

Water Connections	13
Well Pump Sizing	14
System Start Up Procedure	14
Water Corrosion	15
Remedies of Water Problems	16
Lake and Pond Installations	17

Sequence of Operation

Cooling With or Without Duct Heaters	19
Single Stage Heat Without Duct Heaters	19
Two Stage Heat With Duct Heaters	19
Emergency Heat	19

Pressure Tables 25

Quick Reference Trouble-Shooting Chart 26

Thermostat Diagrams 27

Wiring Diagrams 28-30

Ground Source Heat Pump

Performance Report 31-32

Tables

Table 1 Specifications	1
Table 2 Water Coil Pressure Drop	1
Table 3 Indoor Blower Performance	1
Table 4 Accessory Items - Duct Heaters	5
Table 5 Constant Low Valves	13
Table 6A and 6B Capacity & Efficiency Ratings	23
Table 7 Capacity Multiplier Factors	24
Table 8 Correction Factors	24
Table 9 Flow Rates for Various Fluids	24
Table 10 Pressure Table – Cooling	25
Table 10A Pressure Table – Heating	25

Figures

Figure 1 Filter Removal	3
Figure 2 Piping Access to the Unit	3
Figure 3 Optional Terminal Board Cover	4
Figure 4 Duct Heater	5
Figure 5 Connection of Water Lines	6
Figure 6 Components for Circulating System	7
Figure 7	9
Figure 8	9
Figure 9	9
Figure 10 Pump Module Hookup	10
Figure 11	10
Figure 12 Pump Module Hookup Performance ...	11
Figure 13 Pressure and Temperature Sensing Adapter and Components	11
Figure 14 Water Connection Components	14
Figure 15 Cleaning Water Coil	16
Figure 16 Water Well System	18
Figure 17 Functional Components	20
Figure 18 Control Location	20
Figure 19 Water Source Heat Pump - Cooling Cycle	21
Figure 20 Water Source Heat Pump - Heating Cycle	22

**TABLE 1
SPECIFICATIONS**

MODEL	WPV48D	WPV60D
Electrical Rating (60HZV/PH)	230/208-1	230/208-1
Operating Voltage Range	253 - 197	253 - 197
Minimum Circuit Ampacity	34.5	36.0
+ Field Wire Size	#8	#8
++Delay Fuse Max. or Ckt. Bkr.	50	60
Total Unit Amps 230/208	23.7/27.0	25.9/28.8
COMPRESSOR		
Volts	230/208	230/208
Rated Load Amps 230/208	19.0/22.3	21.2/24.1
Branch Ckt. Selection Current	23.7	25.0
Lock Rotor Amps 230/208	129/129	148/148
BLOWER MOTOR and EVAPORATOR		
Blower Motor - HP/Spd	1/2 3-spd	1/2 3-spd
Blower Motor - Amps	4.7	4.7
Face Area Sq. Ft./ Rows/ Fins Per Inch	4.6/3/13	4.6/3/13
SHIPPING WEIGHT LBS.	370	375

**TABLE 2
WATER COIL PRESSURE DROP**

Model	WPV48D, WPV60D	
GPM	PSIG	Ft Hd
4	---	---
5	---	---
6	1.65	3.82
7	2.35	5.43
8	3.10	7.16
9	3.86	8.92
10	4.65	10.75
11	5.50	12.71
12	6.40	14.79
13	7.45	17.22
14	8.60	19.88
15	9.90	22.89

**TABLE 3
INDOOR BLOWER PERFORMANCE
(CFM – DRY COIL WITH FILTER) ①**

Model	WPV48D, WPV60D				
	Without Optional CW45 Installed			With Optional CW45 Installed	
	Motor Speed			Motor Speed	
ESP in WC	High	Medium	Low	High	Medium
.00	1,740	1,650	1,530	1,740	1,600
.10	1,695	1,607	1,510	1,695	1,550
.20	1,650	1,570	1,480	1,650	1,520
.30	1,602	1,532	1,443	1,625	1,500
.40	1,550	1,490	1,400	1,500	1,460
.50	1,490	1,435	1,348	1,440	1,380
.60	1,420	1,365	1,290	1,390	1,310

① For wet coil CFM multiply by .96
ESP = External Static Pressure (inches of water)

APPLICATION AND LOCATION

GENERAL

Units are shipped completely assembled and internally wired, requiring only duct connections, thermostat wiring, 230-208 volt AC power wiring, and water piping. The equipment covered in this manual is to be installed by trained, experienced service and installation technicians. Any heat pump is more critical of proper refrigerant charge and an adequate duct system than a cooling only air conditioning unit.

These instructions and any instructions packaged with any separate equipment required to make up the entire heat pump system should be carefully read before beginning the installation. Note particularly any tags and/or labels attached to the equipment.

While these instructions are intended as a general recommended guide, they do not in any way supersede any national and/or local codes. Authorities having jurisdiction should be consulted before the installation is made.

SHIPPING DAMAGE

Upon receipt of the equipment, the carton should be checked for external signs of shipping damage. If damage is found, the receiving party must contact the last carrier immediately, preferably in writing, requesting inspection by the carrier's agent.

APPLICATION

Capacity of the unit for a proposed installation should be based on heat loss calculations made in accordance with methods of the Air Conditioning Contractors of America, formerly National Warm Air Heating and Air Conditioning Association. The air duct system should be sized and installed in accordance with Standards of the National Fire Protection Association for the Installation of Air Conditioning and Ventilating Systems of Other than Residence Type NFPA No. 90A, and Residence Type Warm Air Heating and Air Conditioning Systems, NFPA No. 90B.

LOCATION

The unit may be installed in a basement, closet or utility room provided adequate service access is insured. Ideally, three sides of the unit should have a minimum access clearance of two feet but the unit can be adequately serviced if two or only one side has a minimum two feet of clearance. The unit should be located in the conditioned space to prevent freezing of the water lines.

Clearance to combustible materials is 0 inches for the heat pump. If an optional duct heater is installed, follow the instructions packed with the duct heater for specifications regarding clearance to combustible material.

Before setting the unit, consider ease of piping, drain and electrical connections for the unit. Also, for units which will be used with a field installed heat recovery unit, consider the proximity of the unit to the water heater or storage tank. Place the unit on a solid base, preferably concrete, to minimize undesirable noise and vibration. DO NOT elevate the base pan on rubber or cork vibration eliminator pads as this will permit the unit base to act like a drum, transmitting objectionable noise.

DUCT WORK

If the unit is to be installed in a closet or utility room which does not have a floor drain, a secondary drain pan under the entire unit is highly recommended.

DO NOT install the unit in such a way that a direct path exists between any return grille and the unit. Rather, insure that the air entering the return grille will make at least one turn before entering the unit air coil. This will reduce possible objectionable compressor and air noise from entering the occupied space.

Design the duct work according to methods given by the Air Conditioning Contractors of America. When duct runs through unconditioned spaces, it should be insulated with vapor barrier. It is recommended that flexible connections be used to connect the duct work to the unit in order to keep the noise transmission to a minimum.

FILTER

This unit must not be operated without a filter. It comes equipped with a disposable filter which should be checked often and replaced if dirty. Insufficient air flow due to undersized duct systems or dirty filters can result in nuisance tripping of the high or low pressure control. Refer to Table 1 for correct air flow and static pressure requirements. See Figure 1

**FIGURE 1
FILTER REMOVAL**

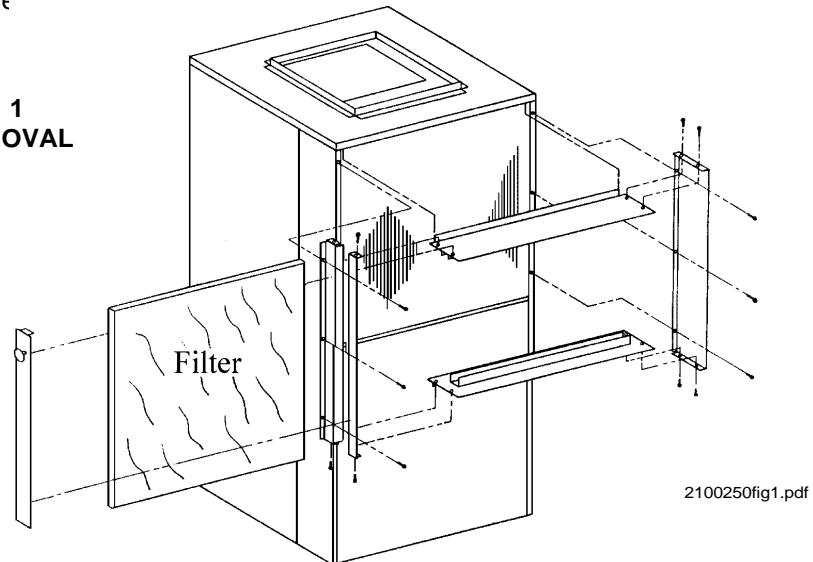

CONDENSATE DRAIN

Determine where the drain line will run. This drain line contains cold water and must be insulated to avoid droplets of water from condensing on the pipe and dropping on finished floors or the ceiling under the unit. A trap **MUST BE** installed in the drain line and the trap filled with water prior to start up. The use of plugged tees in place of elbows to facilitate cleaning is highly recommended.

Drain lines must be installed according to local plumbing codes. It is not recommended that any condensate drain line be connected to a sewer main. The drain line enters the unit through the water access panel, see Figure 2, and connects to the FPT coupling under the condensate drain pan.

PIPING ACCESS TO THE UNIT

Water piping to and from the unit enters the unit casing through the water access panel. Piping connections are made directly to the heat exchanger coil and are 3/4" or 1" FPT. The access panel can be installed on the front of the unit (as received) or on the right side of the unit. It is highly recommended that the piping from the water coil to the outside of the casing be installed while the unit is completely accessible and before it is finally set in position. Two 1 3/4" inch plastic bushings are provided (packed with unit installation instructions) to protect piping from sheet metal edges of access panel. See Figure 2.

**FIGURE 2
PIPING ACCESS TO UNIT**

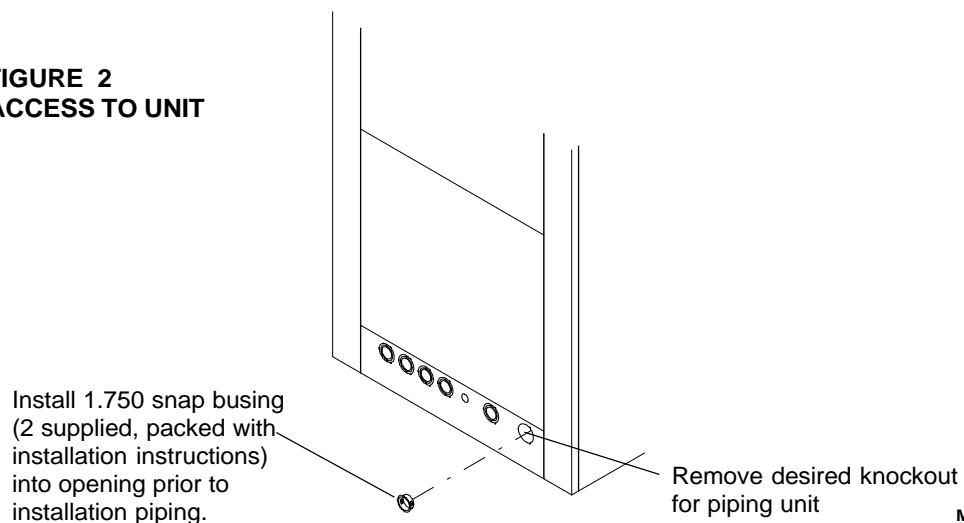

WIRING

All electrical connections are made through the top of the unit. High voltage connections are made with wire nuts to the factory-provided pigtail leads in the junction box. Low voltage connections are made to the terminal strip mounted on the top of the unit. Refer to the wiring diagram for connecting the terminals.

MAIN POWER

Refer to the unit serial plate for wire sizing information and correct protection size. Each unit is marked with a "Minimum Circuit Ampacity." This means that field wiring connections must be sized to carry that amount of current. Each unit and/or wiring diagram is also marked "Use Copper Conductors Only," meaning the leads provided are not suitable for aluminum wiring. Refer to the National Electric Code for complete current-carrying capacity data on the various grades of wiring material.

The unit rating plate lists "Maximum Overcurrent Protective Device" that is to be used with the equipment. This device may be a time delay fuse or HACR type circuit breaker. The correct size overcurrent protective device must be used to provide for proper circuit protection and to avoid nuisance trips due to the momentary high starting current of the compressor motor.

THERMOSTAT LOW VOLTAGE WIRING

A 24 volt terminal strip is mounted on top of the unit with an optional terminal board cover included with the unit installation instructions. See Figure 3. Two types of thermostats are available: 1) Single stage heat, single stage cool to operate the heat pump alone without backup duct style electric heaters. This thermostat is equipped with a signal light to indicate when the unit is "locked out" because of the low temperature or high pressure control. Refer to the wiring diagram 4091-810 for correct connection of the terminals. 2) Two stage heat, single cool to operate the heat pump or duct heaters on heating or the heat pump on cooling. This thermostat is also equipped with a signal light to indicate when the unit is "locked out" because of operation of the low temperature or high pressure control. In addition, a second signal light tells when the unit has been placed in Emergency Heat. Refer to the wiring diagram 4091-811, and to the wiring diagram packed with the duct heater for correct connection of the low voltage terminals.

**FIGURE 3
OPTIONAL TERMINAL BOARD COVER**

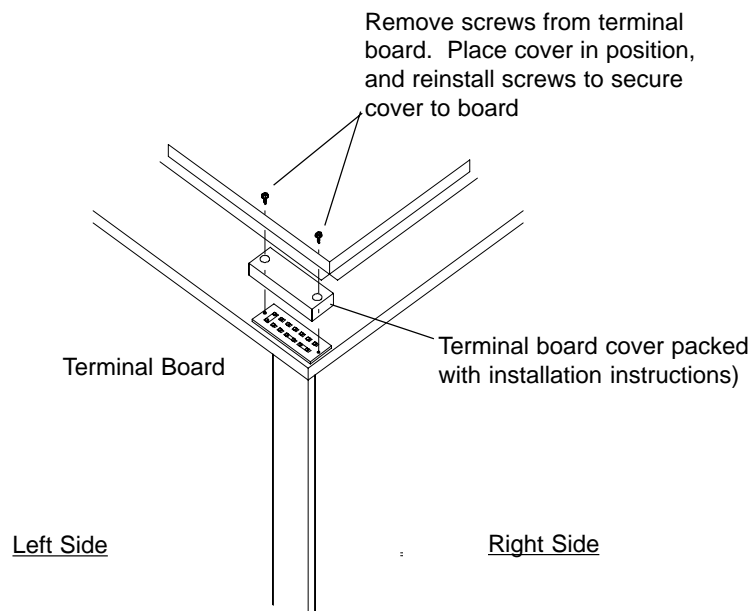

MIS-380

TABLE 4
ACCESSORY ITEMS – DUCT HEATER
(SEE FIGURE 4)

Part No.	PH	Volts	KW	Minimum Ampacity	Wire Size ①		Maximum Fuse	Dimensions					
					CU	AL		A	B	C	D	E	F
8604-080	1	240	5.0	27	#10	#8	30	8	10	4	7	7	12
8604-081	1	240	9.8	52	#6	#4	55	8	10	4	7	7	16
8604-082 ②	1	240	14.7	78	#4	#1	80	15	18	5	11	9	18
8604-083 ②	1	240	19.2	100	#2	#0	100	15	18	5	11	9	18

① Use wire suitable for at least 75° C.

② Fused units (over 48 amperes).

NOTE: All duct heaters are supplied with backup protection and internal fusing as required by NEC.

FIGURE 4
DUCT HEATER

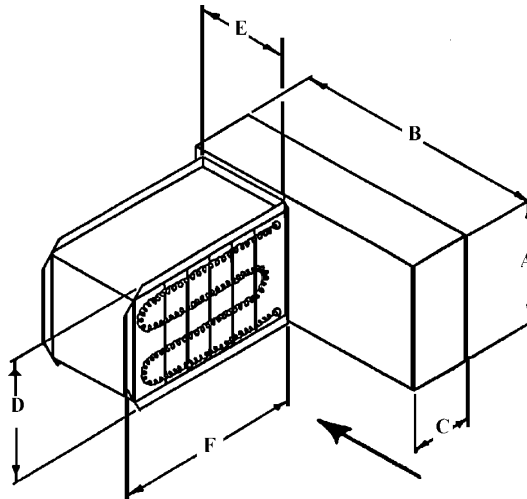

wpv2.tif

The following is a verbal description of the proper procedure for connecting the low voltage hookups for the duct heater. (Refer to wiring diagram 4091-811).

1. Black wire from duct heater to C on the 24 volt terminal block.
2. Green wire from duct heater to green wire from thermostat. These wires must be wire nuted and isolated from the terminal block. Failure to do so will result in improper heater operation.
3. Connect green with tracer from heater to the G terminal on the 24 volt terminal block.
4. Connect the white wire from the heater to W2 on 24 volt terminal block.
 - A. For the 15 and 20 KW duct heaters, connect the white and white with black tracer wires to W2.

ACCESSORIES

ADD-ON DPM26A PUMP MODULE KIT

NOTE: This section applies only if a DPM26A Pump Module is added. Refer to DPM26A instructions for complete installation details.

GENERAL

This high efficiency water source heat pump series was designed with a refrigerant to water heat exchanger commonly known as a desuperheater coil factory-installed for ease in installing optional DPMA pump module kit. The addition of this optional kit allows for heat recovery for hot water heating when connected to a home water heater. The amount of annual hot water supplied and thus additional energy cost savings will depend on the amount of hot water usage and the number of hours the heat pump operates. This pump kit is suitable for potable water.

INSTALLATION

1. Follow all local, state, and national codes applicable to the installation of the pump module kit.
2. Follow the installation instructions received with the DPM26A pump module kit.
3. Connect the water lines between the unit, pump module kit, and the water heater.

**FIGURE 5
CONNECTION OF WATER LINES**

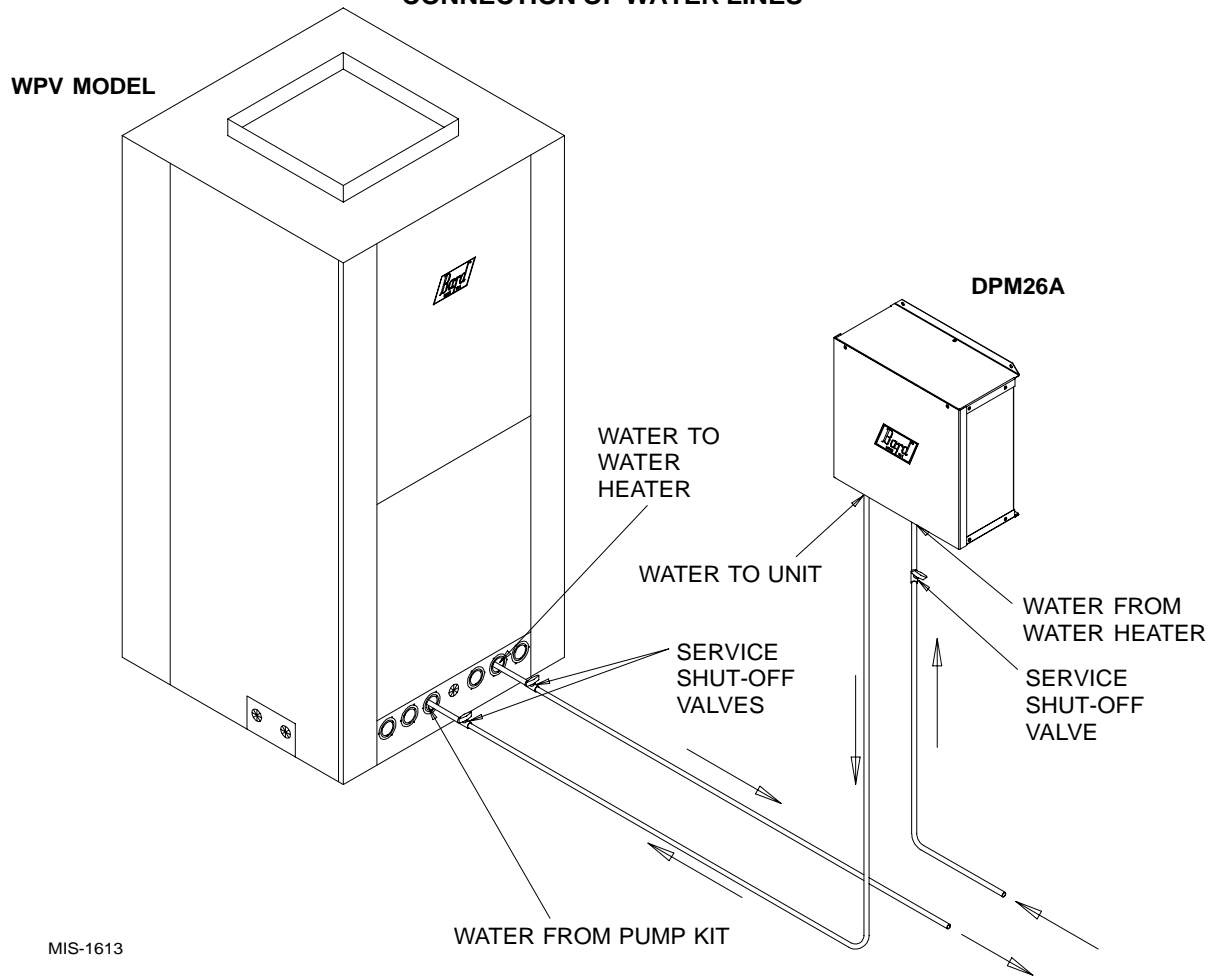

MIS-1613

CLOSED LOOP (Earth Coupled Ground Loop Applications)

NOTE: *Low temperature thermostat must be reset from factory setting to 15° for closed loop applications.*

This unit is designed to work on earth coupled ground loop systems, however, these systems operate at entering water (without antifreeze) temperature well below the temperature normally experienced in water well system.

For information on earth coupled loop design, piping connections to heat pump and installation refer to manual 2100-099, "Earth Coupled Loop System Design Manual," available from your distributor.

THE CIRCULATION SYSTEM DESIGN

Equipment room piping design is based on years of experience with earth coupled heat pump systems. The design eliminates most causes of system failure.

Surprisingly, the heat pump itself is rarely the cause. Most problems occur because designers and installers forget that a closed loop earth coupled heat pump system is NOT like a household plumbing system.

Most household water systems have more than enough water pressure either from the well pump or the municipal water system to overcome the pressure or head loss in 1/2 inch or 3/4 inch household plumbing. A closed loop earth coupled heat pump system, however, is separated from the pressure of the household supply and relies on a small, low wattage pump to circulate the water and antifreeze solution through the earth coupling, heat pump and equipment room components.

The small circulator keeps the operating costs of the system to a minimum. However, the performance of the circulator MUST be closely matched with the pressure or head loss of the entire system in order to provide the required flow through the heat pump. Insufficient flow through the heat exchanger is one of the most common causes of system failure. Proper system piping design and circulator selection will eliminate this problem.

Bard supplies a worksheet to simplify head loss calculations and circulator selection. Refer to "Circulating Pump Worksheet" section in manual 2100-099.

Two general methods are used to pipe the water circuit in the equipment room. The first and easiest to use is to install a pump module. This module comes complete with connecting hose and heat pump adapters available from Bard. A second method is to "site build" the piping at the installation.

To move the transfer fluid (water or antifreeze and water solution) through the earth loop system and the water source heat pump, some type of circulation system is required. Design of circulation system must include provisions for the following. See Figure 6.

1. Selection of a circulation pump or pumps for total system.
2. Providing air bleed off before start-up running.
3. Providing for flow monitoring.
4. Positive pressure control and limiting.
5. Antifreeze charging capability.

NOTE: *The expansion and contraction of earth loop piping may cause a 50 to 60 psig water pressure charge in system between summer to winter.*

**FIGURE 6
COMPONENTS FOR CIRCULATION SYSTEM**

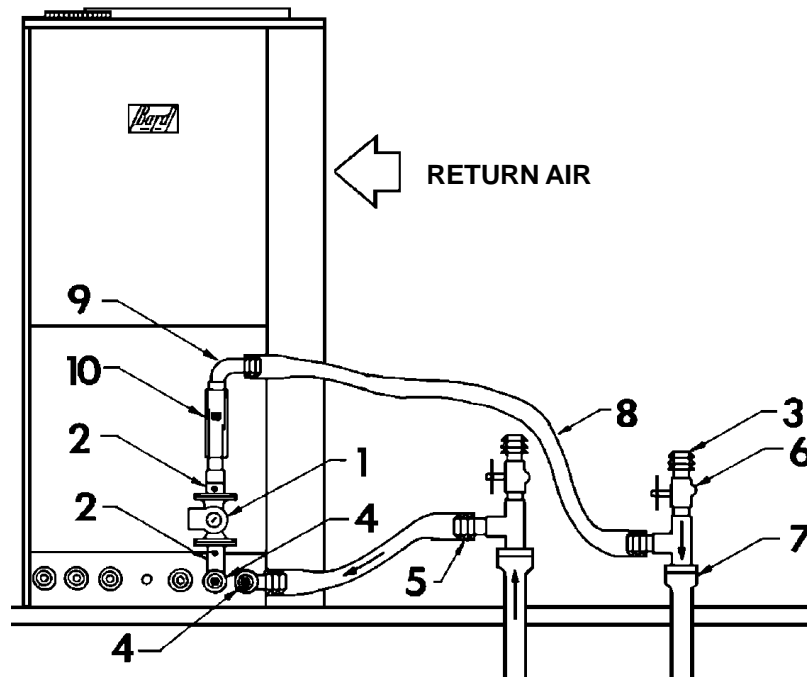

wpv4.tif

The components for a circulation system are as follows: Refer to Figure 6.

1. Circulating pump systems are *engineered for each individual system to provide the correct water flow* and overcome the friction loss of the system piping. Isolation flanges or ball valves are used to insulate pump from system piping. You need to be able to remove the pump from piping without losing the transfer fluid for repairs if ever required.

Determining pressure drop and selecting a circulation pump or pumps. It is very important in selecting the circulating pump that a very accurate pressure drop calculation be made because final pressure drop at the selected pump must pump against will to determine the actual flow rate (GPM) that is delivered to the water source heat pump, the pumping cost and efficiency of the entire system.

2. Ball valve and flange
3. Barb X MIP brass adapter
4. Brass test plugs--in order to start up and troubleshoot a closed loop system properly, water in and water out temperatures at the heat pump must be monitored. A test plug is installed on one leg of each connection line. A probe thermostat can be temporarily inserted, the temperature monitored and the thermometer removed. Use one thermometer to monitor these temperatures. Using two different thermometers to measure the temperature differential can introduce large measurement errors. They are also used to measure pressure drop to determine coil flow rate.
5. Bard X insert brass adapter
6. Two boiler drains are located on both sides of the circulator for final filling, air purging and antifreeze addition.

The top drain should be the highest point in the equipment room piping. This will help purge air out of the system during final filling at start up.

7. PE or PB pipe to fit transition
8. One inch reinforced flexible hose
9. 90° street ell (brass)
10. Flow meter (Bard part No. 8603-017)--or equivalent side to monitor water flow is recommended.

HEAT PUMP CONNECTIONS WITHOUT PUMP KIT

The units have various female connections inside on water coil. To keep losses small, all piping and components in the heat pump should be one inch copper or plastic. The transition to one inch pipe should be made at the exterior of the heat pump if 3/4 inch piping is used in small heat pump models.

Be sure to use a backup wrench when installing the adapters to the heat pump.

PIPING CONNECTIONS

Up to 12 feet of reinforced flexible hose is used. Cut hoses to the desired lengths and install with as few bends as possible. Close bends increase pipe head loss so any bends should be as wide as possible. Use the clamps to secure hoses in position.

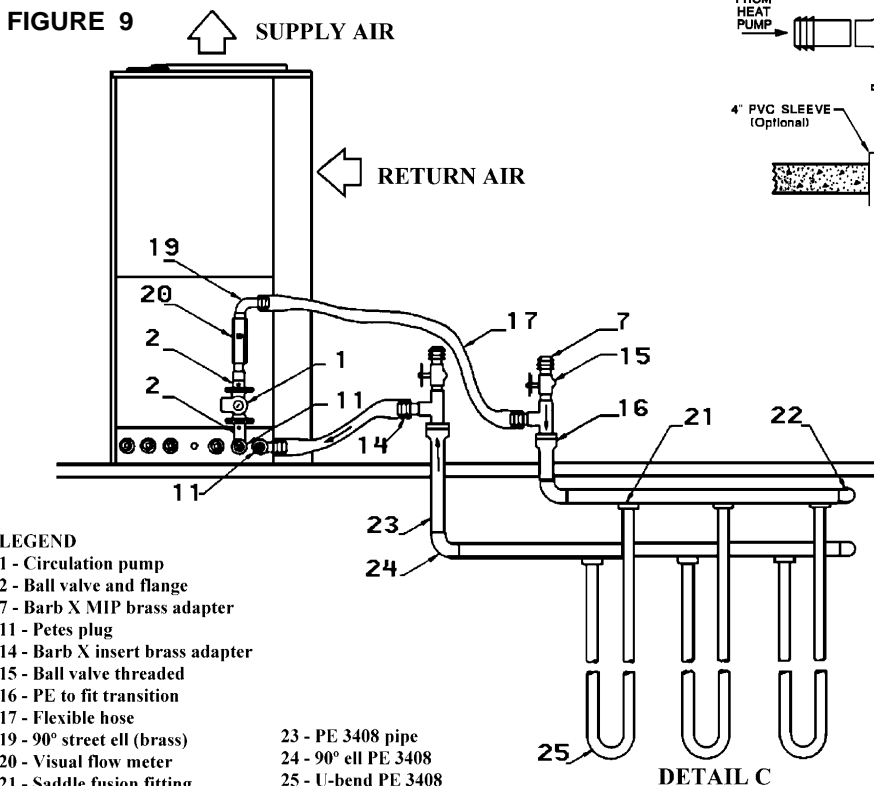
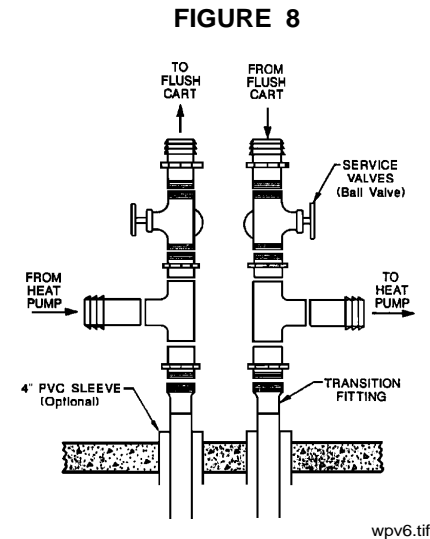
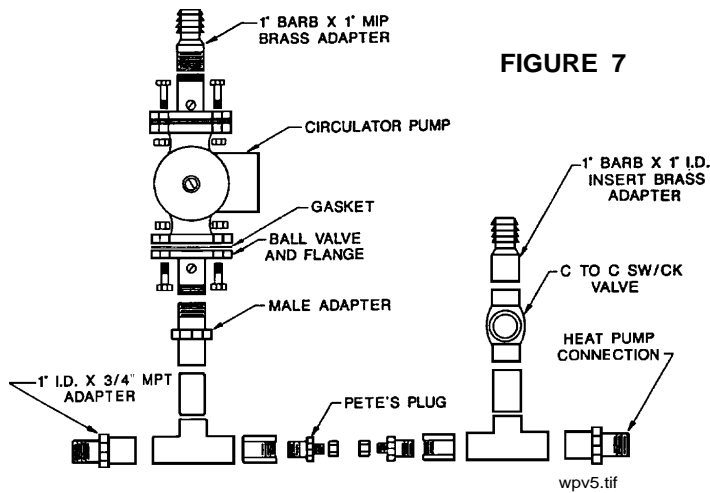

LEGEND

- 1 - Circulation pump
- 2 - Ball valve and flange
- 7 - Barb X MIP brass adapter
- 11 - Petes plug
- 14 - Barb X insert brass adapter
- 15 - Ball valve threaded
- 16 - PE to fit transition
- 17 - Flexible hose
- 19 - 90° street ell (brass)
- 20 - Visual flow meter
- 21 - Saddle fusion fitting
- 22 - End cap

- 23 - PE 3408 pipe
- 24 - 90° ell PE 3408
- 25 - U-bend PE 3408

Polybutylene may also be used in place of Polyethylene pipe shown on drawings.

Drawing courtesy of Oklahoma State University.

wpv7.tif

**FIGURE 10
PUMP MODULE HOOKUP
GPM-1 WITHOUT CABINET SHOWN**

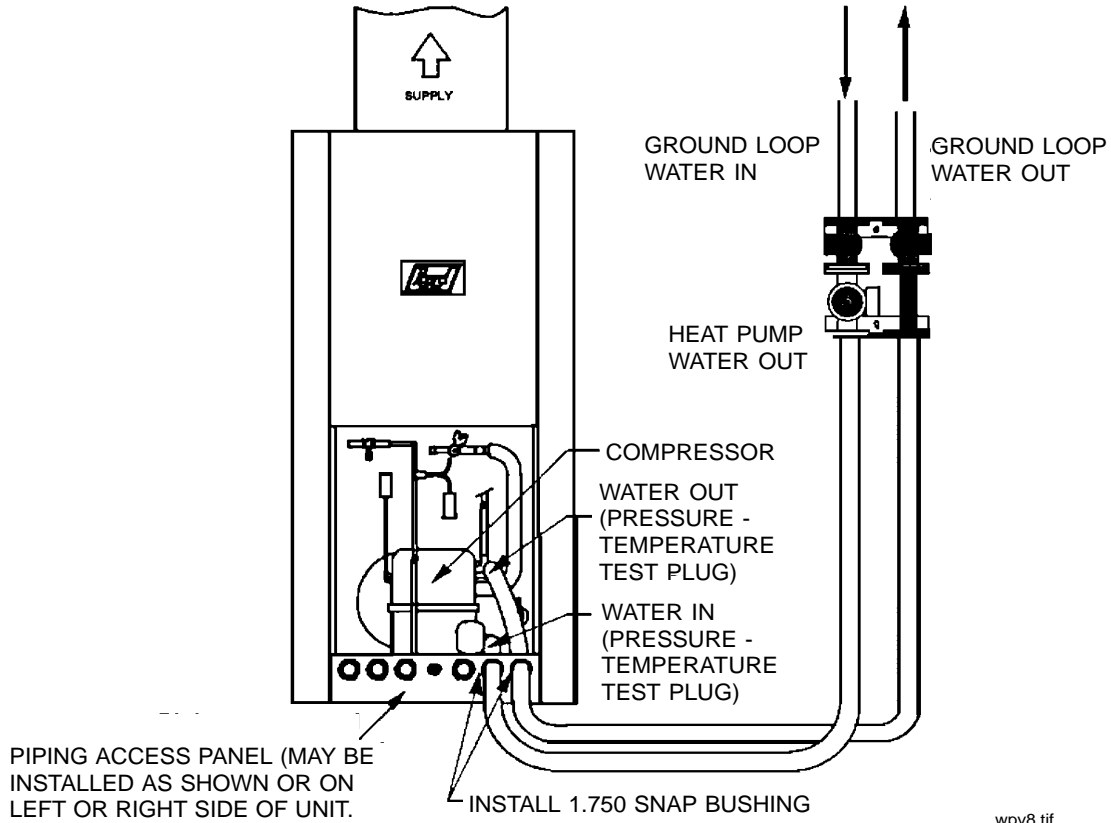

wpv8.tif

FIGURE 11

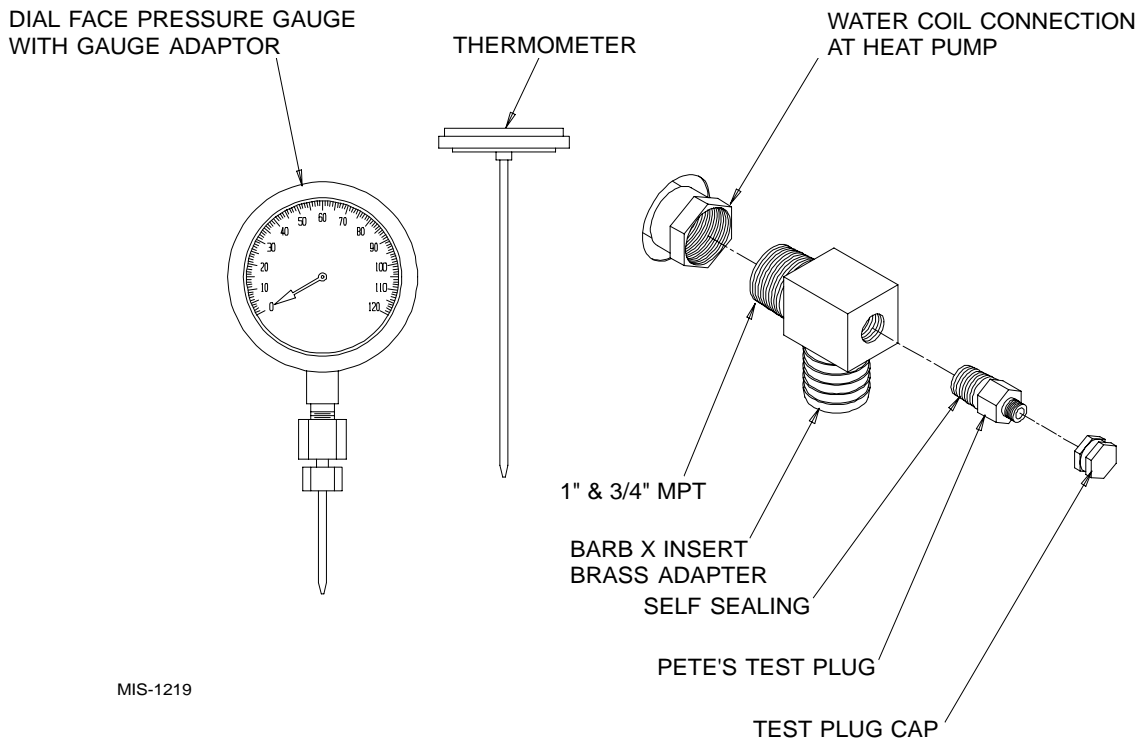

MIS-1219

**FIGURE 12
PUMP MODULE HOOKUP**

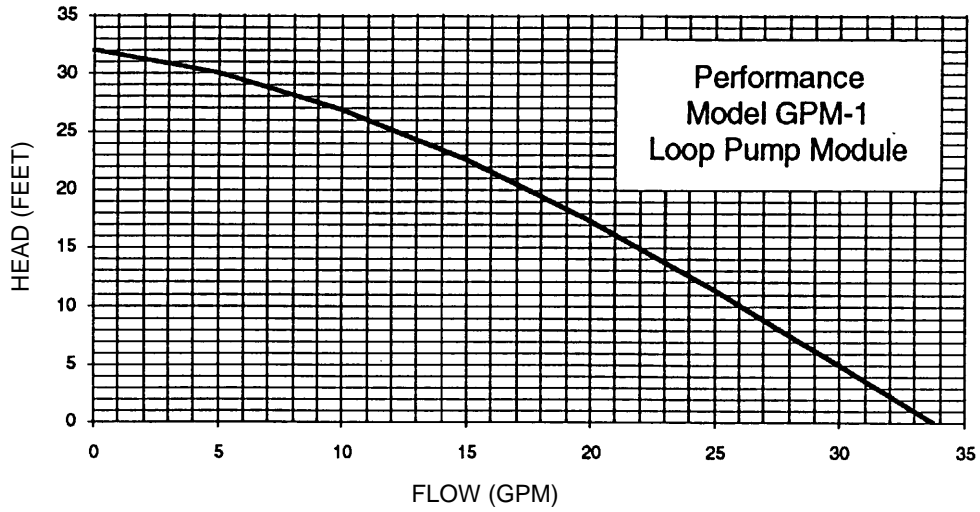

**FIGURE 13
PRESSURE AND TEMPERATURE SENSING ADAPTER AND COMPONENTS**

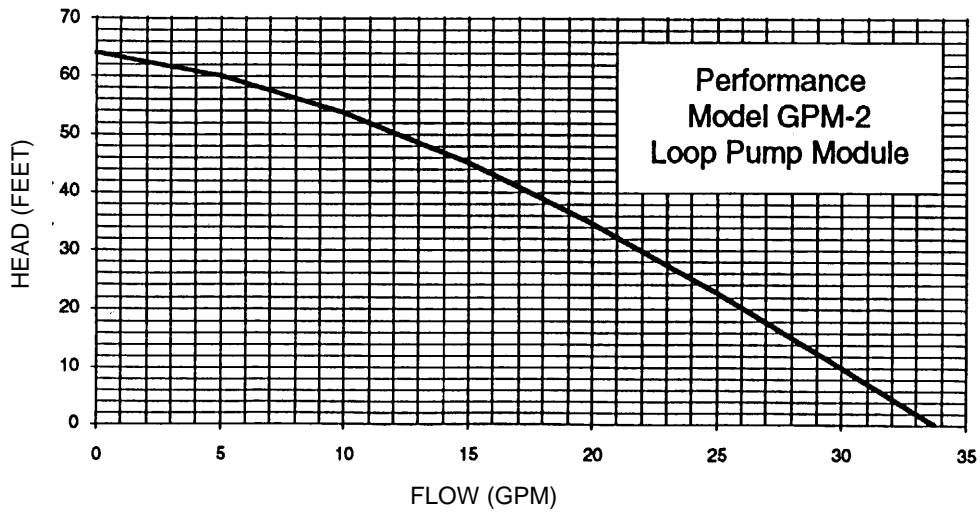

wpv20.tif

SYSTEM START UP PROCEDURE

1. Be sure main power to the unit is OFF at disconnect.
2. Set thermostat system switch to OFF, fan switch to AUTO.
3. Move main power disconnect to ON. Except as required for safety while servicing, DO NOT OPEN THE UNIT DISCONNECT SWITCH.
4. Check system air flow for obstructions.
 - A. Move thermostat fan switch to ON. Blower runs.
 - B. Be sure all registers and grilles are open.
 - C. Move thermostat fan switch to AUTO. Blower should stop.
5. Flush, fill and pressurize the closed loop system as outlined in manual 2100-099.
6. Fully open the manual inlet and outlet valves. Start the loop pump module circulator(s) and check for proper operation. If circulator(s) are not operating, turn off power and diagnose the problem.
7. Check fluid flow using a direct reading flow meter or a single water pressure gauge, measure the pressure drop at the pressure-temperature plugs across the water coil. Compare the measurement with flow versus pressure drop table to determine the actual flow rate. If the flow rate is too low, recheck the selection of the loop pump module model for sufficient capacity. If the module selection is correct, there is probably trapped air or a restriction in the piping circuit.
8. Start the unit in cooling mode. By moving the thermostat switch to cool, fan should be set for AUTO.
9. Check the system refrigerant pressures against the cooling refrigerant pressure table in the installation manual for rated water flow and entering water temperatures. If the refrigerant pressures do not match, check for air flow problem then refrigeration system problem.
10. Switch the unit to the heating mode. By moving the thermostat switch to heat, fan should be set for AUTO.
11. Check the refrigerant system pressures against the heating refrigerant pressure table in installation manual. Once again, if they do not match, check for air flow problems and then refrigeration system problems.

NOTE: If a charge problem is determined (high or low):

 - A. Check for possible refrigerant leaks.
 - B. Recover all remaining refrigerant from unit and repair leak.
 - C. Evacuate unit down to 29 inches of vacuum.
 - D. Recharge the unit with refrigerant by weight. This is the only way to insure a proper charge.

OPEN LOOP (Well System Applications)

NOTE: Low temperature thermostat factory set to 25° for open loop applications.

It is very important that an adequate supply of clean, noncorrosive water at the proper pressure be provided before the installation is made. Insufficient water, in the heating mode for example, will cause the low temperature control to trip, shutting down the heat pump. In assessing the capacity of the water system, it is advisable that the complete water system be evaluated to prevent possible lack of water or water pressure at various household fixtures whenever the heat pump turns on. All plumbing to and from the unit is to be installed in accordance with local plumbing codes. The use of plastic pipe, where permissible, is recommended to prevent electrolytic corrosion of the water pipe. Because of the relatively cold temperatures encountered with well water, it is strongly recommended that the water lines connecting the unit be insulated to prevent water droplets from condensing on the pipe surface.

Refer to piping, Figure 14. Slow closing Solenoid Valve (6) with a 24V coil provides on/off control of the water flow to the unit. Refer to the wiring diagram for correct hookup of the valve solenoid coil.

Constant Flow Valve (7) provides correct flow of water to the unit regardless of variations in water pressure. Observe the water flow direction indicated by the arrow on the side of the valve body. Following is a table showing which valve is to be installed with which heat pump.

**TABLE 5
CONSTANT FLOW VALVES**

Part No.	Min. Available Pressure PSIG	Flow Rate GPM
8603-007	15 (1)	6
8603-008	15 (1)	8
8603-010	15 (1)	4
8603-011	15 (1)	5

- (1) The pressure drop through the constant flow valve will vary depending on the available pressure ahead of the valve. Unless a minimum of 15 PSIG is available **immediately** ahead of the valve, no water will flow.

Strainer (5) installed upstream of constant flow valve (7) to collect foreign material which would clog the flow valve orifice.

Figure 14 shows the use of shut-off valves (9) and (11), on the in and out water lines to permit isolation of the unit from the plumbing system should future service work require this. Globe valves should not be used as shut-off valves because of the excessive pressure drop inherent in the valve design. Instead use gate or ball valves as shut-offs so as to minimize pressure drop.

Drain cocks (8) and (10) and tees have been included to permit acid cleaning the refrigerant-to-water coil should such cleaning be required. See *WATER CORROSION*.

Drain cock (12) provides access to the system to check water flow through the constant flow valve to insure adequate water flow through the unit. A water meter 1-10 GPM (8603-013) is used to check the water flow rate.

FIGURE 14
WATER CONNECTION COMPONENTS

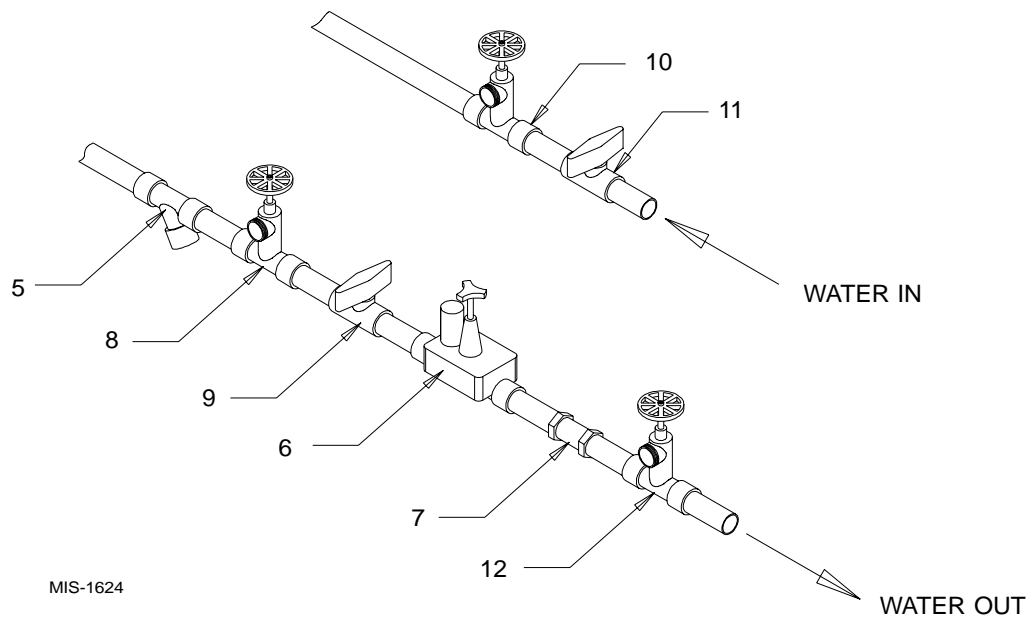

WELL PUMP SIZING

Strictly speaking, sizing the well pump is the responsibility of the well drilling contractor. It is important, however, that the HVAC contractor be familiar with the factors that determine what size pump will be required. Rule of thumb estimates will invariably lead to under or oversized well pumps. Undersizing the pump will result in inadequate water to the whole plumbing system but with especially bad results to the heat pump--NO HEAT/ NO COOL calls will result. Oversized pumps will short cycle and could cause premature pump motor or switch failures.

The well pump must be capable of supplying enough water and at an adequate pressure to meet competing demands of water fixtures. The well pump must be sized in such a way that three requirements are met:

1. Adequate flow rate in GPM
2. Adequate pressure at the fixture.
3. Able to meet the above from the depth of the well-feet of lift.

The pressure requirements put on the pump are directly affected by the diameter of pipe being used, as well as, by the water flow rate through the pipe. The worksheet included in manual 2100-078 should guarantee that the well pump has enough capacity. It should also ensure that the piping is not undersized which would create too much pressure due to friction loss. High pressure losses due to undersized pipe will reduce efficiency and require larger pumps and could also create water noise problems.

SYSTEM START UP PROCEDURE

1. Be sure main power to the unit is OFF at disconnect.
2. Set thermostat system switch to OFF, fan switch to AUTO.
3. Move main power disconnect to ON. Except as required for safety while servicing -- DO NOT OPEN THE UNIT DISCONNECT SWITCH.

4. Check system air flow for obstructions.
 - A. Move thermostat fan switch to ON. Blower runs.
 - B. Be sure all registers and grilles are open.
 - C. Move thermostat fan switch to AUTO. Blower should stop.
5. Fully open the manual inlet and outlet valves.
6. Check water flow.
 - A. Connect a water flow meter to the drain cock between the constant flow valve and the solenoid valve. Run a hose from the flow meter to a drain or sink. Open the drain cock.
 - B. Check the water flow rate through constant flow valve to be sure it is the same as the unit is rated for. (Example 4 GPM for a WPV30).
 - C. When water flow is okay, close drain cock and remove the water flow meter. The unit is now ready to start.
7. Start the unit in cooling mode. By moving the thermostat switch to cool, fan should be set for AUTO.
 - A. Check to see the solenoid valve opened.
8. Check the system refrigerant pressures against the cooling refrigerant pressure table in the installation manual for rated water flow and entering water temperatures. If the refrigerant pressures do not match, check for air flow problem then refrigeration system problem.
9. Switch the unit to the heat mode. By moving the thermostat switch to heat, fan should be set for AUTO.
 - A. Check to see the solenoid valve opened again.
10. Check the refrigerant system pressures against the heating refrigerant pressure table in installation manual. Once again, if they do not match, check for air flow problems and then refrigeration system problems.

NOTE: If a charge problem is determined (high or low):

 - A. Check for possible refrigerant loss.
 - B. Discharge all remaining refrigerant from unit.
 - C. Evacuate unit down to 29 inches of vacuum.
 - D. Recharge the unit with refrigerant by weight. This is the only way to insure a proper charge.

WATER CORROSION

Two concerns will immediately come to light when considering a water source heat pump, whether for ground water or for a closed loop application: Will there be enough water? And, how will the water quality affect the system?

Water quantity is an important consideration and one which is easily determined. The well driller must perform a pump down test on the well according to methods described by the National Well Water Association. This test, if performed correctly, will provide information on the rate of flow and on the capacity of the well. It is important to consider the overall capacity of the well when thinking about a water source heat pump because the heat pump may be required to run for extended periods of time.

The second concern, about water quality, is equally important. Generally speaking, if the water is not offensive for drinking purposes, it should pose no problem for the heat pump. The well driller or local water softening company can perform tests which will determine the chemical properties of the well water.

Water quality problems will show up in the heat pump in one or more of the following ways:

1. Decrease in water flow through the unit.
2. Decreased heat transfer of the water coil (entering to leaving water temperature difference is less).

There are four main water quality problems associated with ground water. These are:

1. Biological Growth. This is the growth of microscopic organisms in the water and will show up as a slimy deposit through out the water system. Shock treatment of the well is usually required and this is best left up to the well driller. The treatment consists of injecting chlorine into the well casing and flushing the system until all growth is removed.
2. Suspended Particles in the Water. Filtering will usually remove most suspended particles (fine sand, small gravel) from the water. The problem with suspended particles in the water is that it will erode metal parts, pumps, heat transfer coils, etc. So long as the filter is cleaned and periodically maintained, suspended particles should pose no serious problem. Consult with your well driller.
3. Corrosion of Metal. Corrosion of metal parts results from either highly corrosive water (acid water, generally not the case with ground water) or galvanic reaction between dissimilar metals in the presence of water. By using plastic plumbing or dielectric unions galvanic reaction is eliminated. The use of corrosion resistant materials (such as the Cupro Nickel coil) through the water system will reduce corrosion problems significantly.
4. Scale Formation. Of all the water problems, the formation of scale by ground water is by far the most common. Usually this scale is due to the formation of calcium carbonate by magnesium carbonate or calcium sulfate may also be present. Carbon dioxide gas (CO₂), the carbonate of calcium and magnesium carbonate, is very soluble in water. It will remain dissolved in the water until some outside factor upsets the balance. This outside influence may be a large change in water temperature or pressure. When this happens, enough carbon dioxide gas combines with dissolved calcium or magnesium in the water and falls out of solution until a new balance is reached. The change in temperature that this heat pump produces is usually not high enough to cause the dissolved gas to fall out of solution. Likewise, if pressure drops are kept to a reasonable level, no precipitation of carbon dioxide should occur.

REMEDIES OF WATER PROBLEMS

Water Treatment. Water treatment can usually be economically justified for closed loop systems. However, because of the large amounts of water involved with a ground water heat pump, water treatment is generally too expensive.

Acid Cleaning the Water Coil or Heat Pump Recovery Unit. If scaling of the coil is strongly suspected, the coil can be cleaned up with a solution of Phosphoric Acid (food grade acid). Follow the manufacturer's directions for mixing, use, etc. Refer to the "Cleaning Water Coil," Figure 15. The acid solution can be introduced into the heat pump coil through the hose bib (part 8 of Figure 15). Be sure the isolation valves (parts 9 and 11 of Figure 15) are closed to prevent contamination of the rest of the system by the coil. The acid should be pumped from a bucket into the hose bib (part 8 of Figure 15) and returned to the bucket through the other hose bib (part 10 of Figure 15). Follow the manufacturer's directions for the product used as to how long the solution is to be circulated, but it is usually circulated for a period of several hours.

**FIGURE 15
CLEANING WATER COIL**

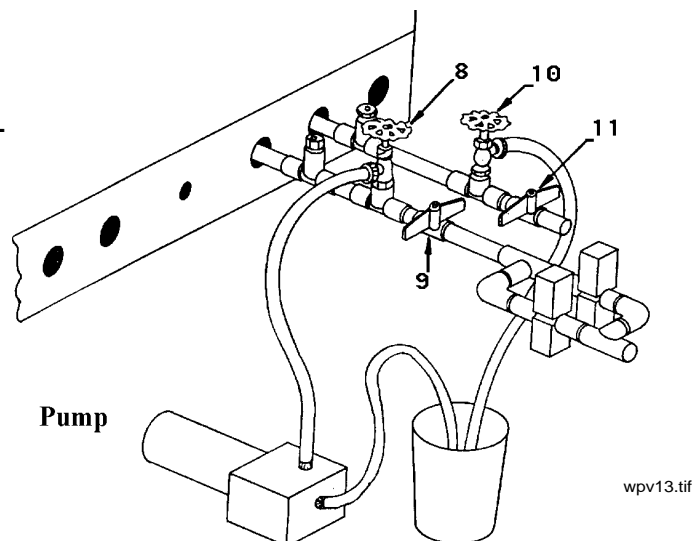

LAKE AND POND INSTALLATIONS

Lakes and ponds can provide a low cost source of water for heating and cooling with a ground water heat pump. Direct usage of the water without some filtration is not recommended as algae and turbid water can foul the water to freon heat exchanger. Instead, there have been very good results using a dry well dug next to the water line or edge. Normal procedure in installing a dry well is to backhoe a 15 to 20 foot hole adjacent to the body of water (set backhoe as close to the water's edge as possible). Once excavated, a perforated plastic casing should be installed with gravel backfill placed around the casing. The gravel bed should provide adequate filtration of the water to allow good performance of the ground water heat pump. Refer to Figure 16.

The following is a list of recommendations to following when installing this type of system:

- A. A lake or pond should be at least 1 acre (40,000 square feet) in surface area for each 50,000 BTUs of ground water heat pump capacity or have 2 times the cubic feet size of the dwelling that you are trying to heat (includes basement if heated).
- B. The average water depth should be at least 5 feet and there should be an area where the water depth is at least 12 to 15 feet deep.
- C. If possible, use a submersible pump suspended in the dry well casing. Jet pumps and other types of suction pumps normally consume more electrical energy than similarly sized submersible pumps. Pipe the unit the same as a water well system.
- D. Size the pump to provide necessary GPM for the ground water heat pump. A 12 GPM or greater water flow rate is required on all modes when used on this type system.
- E. A pressure tank should be installed in dwelling to be heated adjacent to the ground water heat pump. A pressure switch should be installed at the tank for pump control.
- F. All plumbing should be carefully sized to compensate for friction losses, etc., particularly if the pond or lake is over 200 feet from the dwelling to be heated or cooled.
- G. Keep all water lines below low water level and below the frost line.
- H. Most installers use 4 inch field tile (rigid plastic or corrugated) for water return to the lake or pond.
 - I. The drain line discharge should be located at least 100 feet from the dry well location.
 - J. The drain line should be installed with a slope of 2 inches per 10 feet of run to provide complete drainage of the line when the ground water heat pump is not operating. This gradient should also help prevent freezing of the discharge where the pipe terminates above the frost line.
- K. Locate the discharge high enough above high water level so the water will not back up and freeze inside the drain pipe.
- L. Where the local conditions prevent the use of a gravity drainage system to a lake or pond, you can instead run standard plastic piping out into the pond below the frost and low water level.



WARNING

Thin ice may result in the vicinity of the discharge line.

For complete information on water well systems and lake and pond applications, refer to Manual 2100-078 available from your distributor.

FIGURE 16
WATER WELL SYSTEM

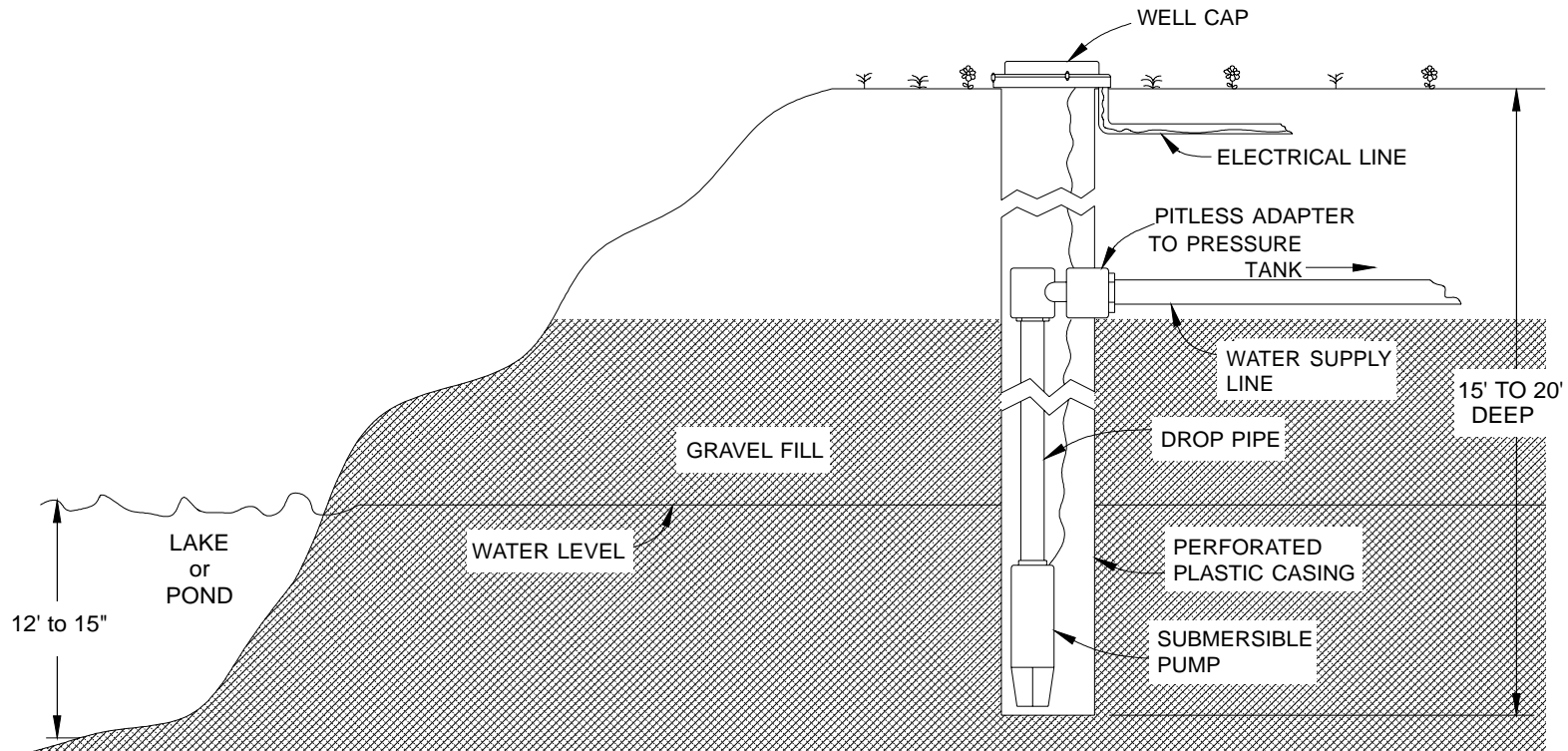

SEQUENCE OF OPERATION

1. COOLING WITH OR WITHOUT DUCT HEATERS

Whenever the system lever is moved to COOL, thermostat system switch completes a circuit R to O, energizing the reversing valve solenoid. On a call for cooling, the cooling bulb completes a circuit from R to G, energizing the blower relay coil. The blower relay contacts complete a 230 volt circuit to the blower motor and the blower operates. R to Y circuit is completed at the same time as the fan circuit and current flows from Y to terminal 4 at the lockout relay. Terminal 4 of the lockout relay provides two paths for current flow.

- A. Through the lockout relay coil which offers the resistance of the lockout relay coil.
- B. Through the normally closed contacts of the lockout relay to terminal 5 of the lockout relay and then through the high and low pressure switches to the compressor contactor coil.

If the high pressure and low temperature switches remain closed (refrigerant pressure and temperature remains normal), the path of least resistance is through these safety controls to the compressor contactor coil. The contacts of the compressor contactor complete a 230 volt circuit to the compressor and the compressor runs. If discharge pressure reaches the set point of the high pressure control, the normally closed contacts of the high pressure control open and current no longer flows to the compressor contact coil--the coil drops out. Current now can take the path of least resistance through the lockout relay coil, energizing the lockout relay coil and opening terminals 4 and 5 of the lockout relay. The lockout relay will remain energized as long as a circuit is completed between R and Y at the thermostat. In the meantime, since the compressor is operating, refrigerant pressure will equalize and the high pressure switch will automatically reset. However, the circuit to the compressor contact will not be complete until the lockout relay is de-energized by moving the thermostat system switch to OFF, breaking the circuit from R to Y dropping out the lockout relay coil and permitting terminals 4 and 5 to make. When the high pressure switch closes, a circuit is complete to L at the thermostat, energizing the signal light to indicate a malfunction. When the system switch is moved from OFF to COOL, the cycle is repeated.

2. SINGLE STAGE HEAT WITHOUT DUCT HEATERS

Compressor circuit R to Y including lockout relay and pressure controls is the same as cooling. Blower circuit R to G is the same as cooling. With system switch set to HEAT, no circuit is completed between R and O and reversing valve solenoid is not energized.

3. TWO STAGE HEAT WITH DUCT HEATERS

First stage heat is the same as single heating without duct heater. When the second stage thermostat bulb makes, a circuit is completed from C to W2, energizing the duct heater heat contactor, through the heating element and manual reset limit. C to W2 also simultaneously energizes the 24 volt coil on the interlock relay, closing the contacts, which in turn energize the low voltage coil on the blower relay to close the high voltage contacts and power the blower motor. The elements and blower remain energized as long as C to W2 are made.

4. EMERGENCY HEAT

When the system switch is moved to EMER, the compressor circuit R to Y is disconnected. Control of the electric heaters is from C to W2 and W3 through the thermostat second stage heating bulb. Blower operation is controlled by the second stage heating bulb. Operation is the same as above, "Two Stage Heat with Duct Heaters."

FIGURE 17

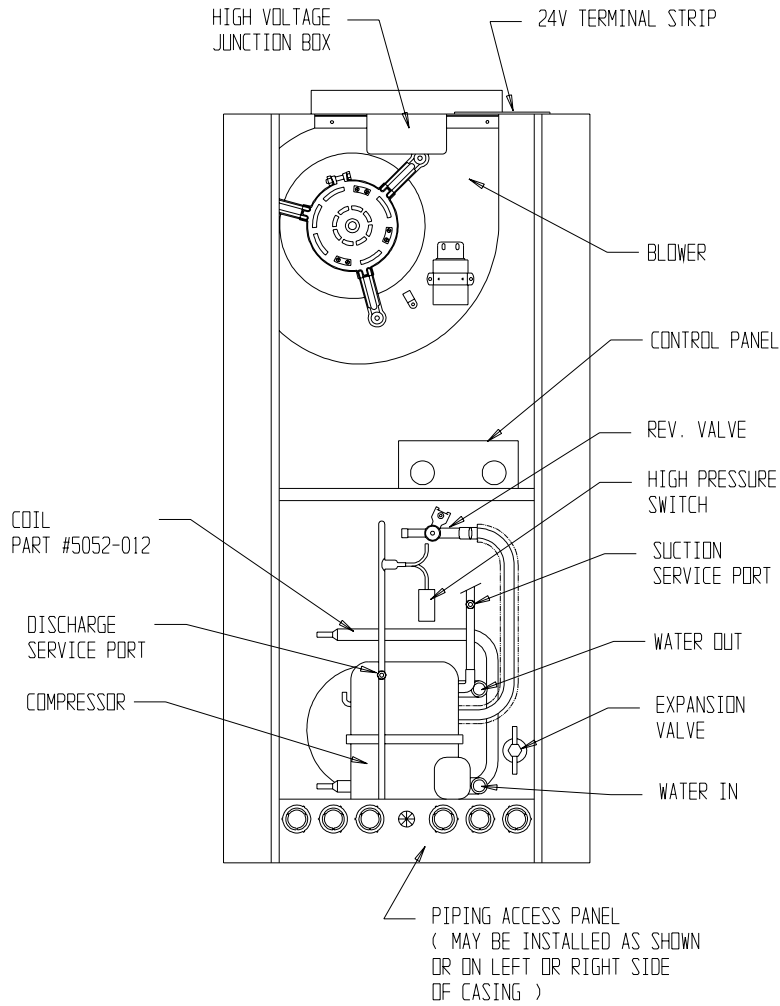

MIS-096

NOTE: IF NO RETURN AIR DUCT IS USED, APPLICABLE INSTALLATION CODES MAY LIMIT THIS CABINET TO INSTALLATION ONLY IN A SINGLE STORY STRUCTURE.

FIGURE 18

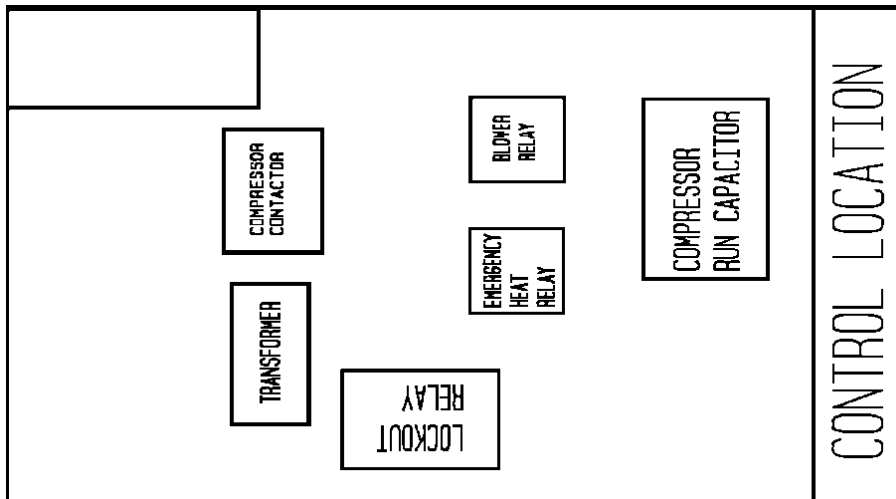

wpv13.tif

**FIGURE 19
WATER SOURCE HEAT PUMP
COOLING CYCLE**

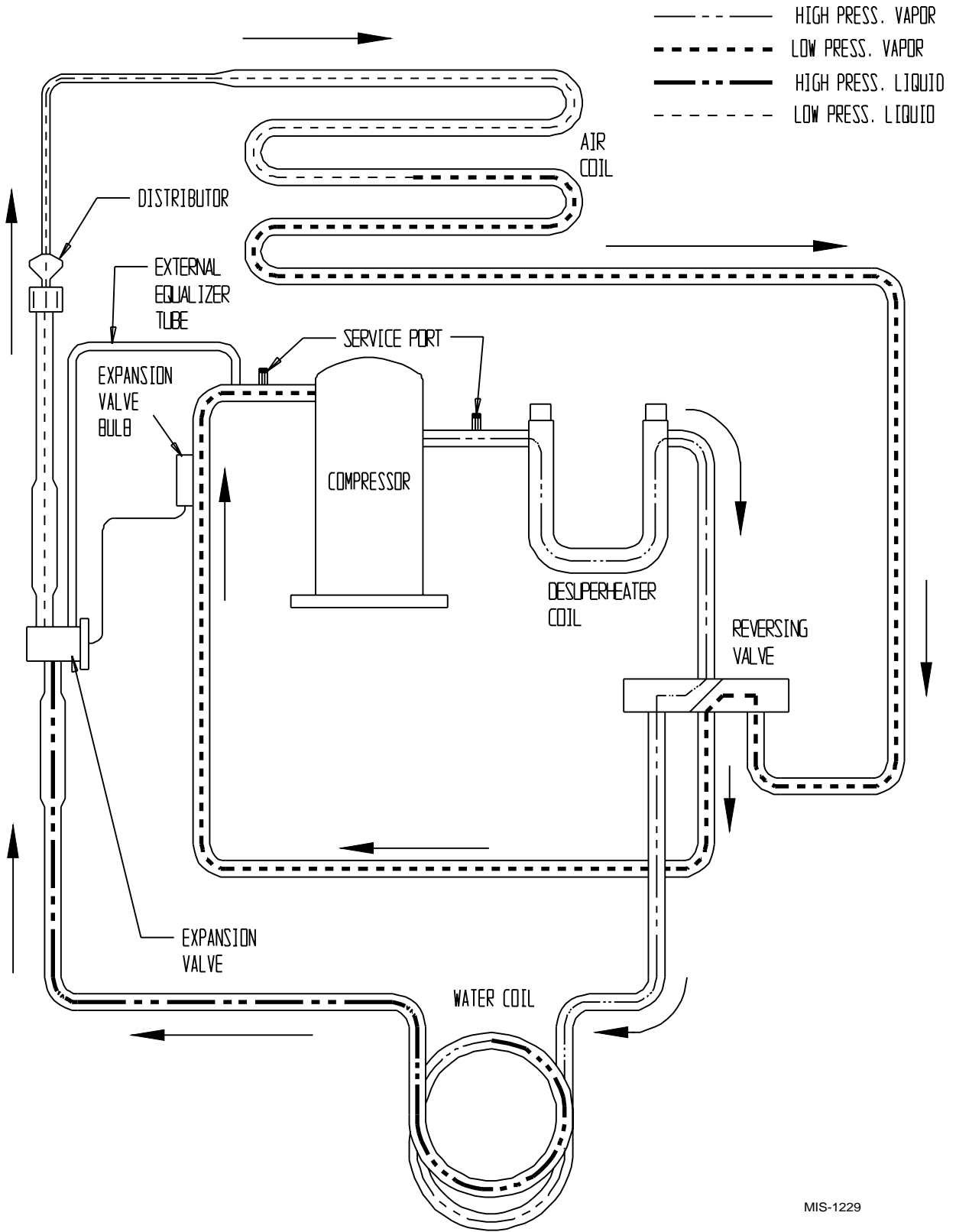

MIS-1229

**FIGURE 20
WATER SOURCE HEAT PUMP
HEATING CYCLE**

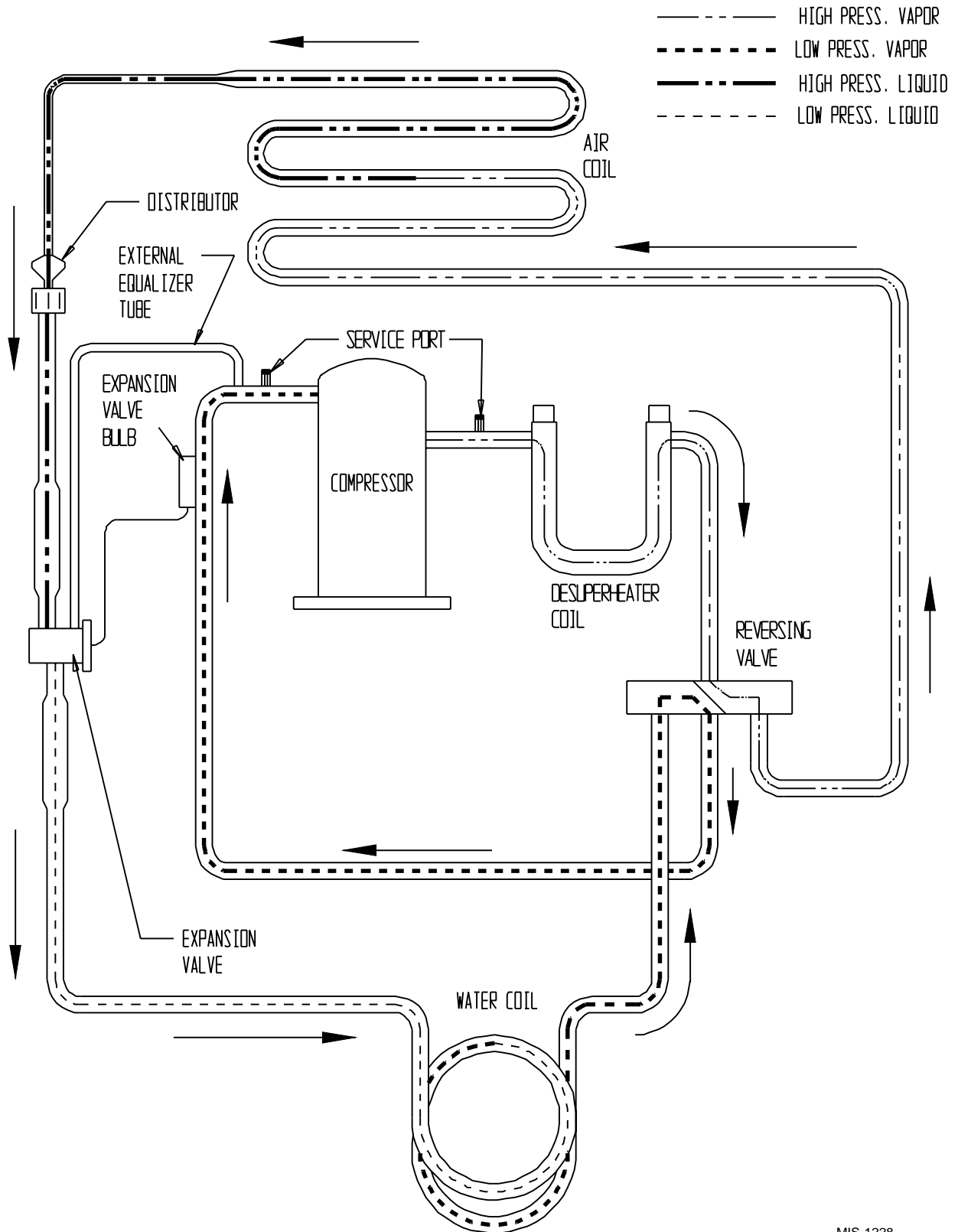

MIS-1228

**CAPACITY AND EFFICIENCY APPLICATION RATINGS
BASED ON 15% SODIUM CHLORIDE**

TABLES 6A - 6B

MODEL WPV48D 1,550 CFM 9 GPM

TABLE 6A

Dry Bulb/ Wet Bulb	Cooling Capacity	Fluid Temperature Entering Water Coil Degrees F								
		30 ②	40 ②	50	60	70	80	90	100	110
75 / 62	Total Cooling	54,467	82,378	50,290	48,201	46,112	44,023	41,934	39,845	37,756
	Sensible Cooling	37,675	36,346	35,017	33,687	32,358	31,029	29,699	28,370	27,041
	Total Heat of Rejection	62,530	61,486	60,442	59,397	58,353	57,308	56,264	55,219	54,175
	EER ①	18.97	17.43	15.89	14.34	12.80	11.26	9.71	8.17	6.63
80 / 67	Total Cooling	57,944	55,722	53,500	51,277	49,055	46,833	44,611	42,388	40,166
	Sensible Cooling	38,840	37,470	36,100	34,729	33,359	31,988	30,618	29,248	27,877
	Total Heat of Rejection	66,522	65,411	64,300	63,188	62,077	60,966	59,855	58,744	57,633
	EER ①	19.58	17.99	16.40	14.80	13.21	11.62	10.02	8.43	6.84
85 / 72	Total Cooling	63,738	61,294	58,850	56,405	53,961	51,516	49,072	46,627	44,183
	Sensible Cooling	40,782	39,343	37,905	36,466	35,027	33,588	32,149	30,710	29,271
	Total Heat of Rejection	73,174	71,952	70,730	69,507	68,285	67,063	65,841	64,618	63,396
	EER ①	20.91	19.21	17.51	15.81	14.11	12.41	10.71	9.01	7.30

Dry Bulb	Heating Capacity	Fluid Temperature Entering Water Coil Degrees F							
		25 ②	30 ②	40 ②	50	60	70	80	90
70	Total Heating	32,500	35,000	40,000	45,000	50,000	55,000	60,000	65,000
	Total Heat of Absorption	21,516	23,933	28,766	33,600	38,433	43,266	48,100	52,933
	COP ①	2.76	2.90	3.12	3.35	3.57	3.79	4.01	4.233

MODEL WPV60D 1,570 CFM 11 GPM
--

TABLE 6B

Dry Bulb/ Wet Bulb	Cooling Capacity	Fluid Temperature Entering Water Coil Degrees F								
		30 ②	40 ②	50	60	70	80	90	100	110
75 / 62	Total Cooling	58,777	57,071	55,366	53,660	51,954	50,248	48,542	46,836	45,130
	Sensible Cooling	44,972	42,759	40,546	38,332	36,119	33,906	31,693	29,480	27,267
	Total Heat of Rejection	65,511	65,232	64,954	64,675	64,396	64,118	63,839	63,561	63,282
	EER ①	19.61	18.04	16.47	14.90	13.33	11.76	10.20	8.63	7.06
80 / 67	Total Cooling	62,529	60,714	58,900	57,085	55,270	53,455	51,640	49,825	48,011
	Sensible Cooling	46,362	44,081	41,800	39,518	37,237	34,935	32,674	30,392	28,111
	Total Heat of Rejection	69,692	69,396	69,100	68,803	68,507	68,211	67,914	67,618	67,322
	EER ①	20.23	18.61	17.00	15.38	13.76	12.14	10.52	8.90	7.28
85 / 72	Total Cooling	63,738	61,294	58,850	56,405	53,961	51,516	49,072	46,627	44,183
	Sensible Cooling	40,782	39,343	37,905	36,466	35,027	33,588	32,149	30,710	29,271
	Total Heat of Rejection	73,174	71,952	70,730	69,507	68,285	67,063	65,841	64,618	63,396
	EER ①	20.91	19.21	17.51	15.81	14.11	12.41	10.71	9.01	7.30

Dry Bulb	Heating Capacity	Fluid Temperature Entering Water Coil Degrees F							
		25 ②	30 ②	40 ②	50	60	70	80	90
70	Total Heating	32,500	35,000	40,000	45,000	50,000	55,000	60,000	65,000
	Total Heat of Absorption	21,516	23,933	28,766	33,600	38,433	43,266	48,100	52,933
	COP ①	2.79	2.90	3.12	3.35	3.57	3.79	4.01	4.21

**TABLE 7
CAPACITY MULTIPLIER FACTORS**

% of Rated Air Flow	-10	Rated	10
Total Btuh	0.975	1.00	1.02
Sensible Btuh	0.950	1.00	1.05

**TABLE 8
CORRECTION FACTORS FOR PERFORMANCE
AT OTHER WATER FLOWS**

Rated Flow Plus - GPM	Heating		Cooling	
	Btuh	Watts	Btuh	Watts
2	1.00	98	1.01	1.00
4	1.01	97	1.03	1.01
6	1.02	96	1.05	1.02
8	1.02	95	1.06	1.02

**TABLE 9
FLOW RATES FOR VARIOUS FLUIDS**

* Flow Rates for Various Fluids	WPV48D	WPV60D
Flow rate required GPM fresh water	6	8
Flow rate required GPM 15% sodium chloride	9	11
Flow rate required GPM 25%GS4	9	11

**TABLES 10 & 10A
PRESSURE TABLES**

COOLING

Fluid Temperature Entering Water Coil °F

Model	Room Air Temperature	Pressure	30°	35°	40°	45°	50°	55°	60°	65°	70°	75°	80°	85°	90°	95°	100°	105°	110°	
WPV48D	75° DB 62° WB	Low Side	68	67	67	66	66	65	65	65	64	64	63	63	63	62	62	61	61	
		High Side	111	121	132	142	153	163	174	184	195	205	215	225	235	246	256	267	277	
	80° DB 67° WB	Low Side	73	72	72	71	71	70	70	70	69	69	68	68	68	68	67	67	66	66
		High Side	114	125	136	146	157	167	178	189	200	211	221	232	243	254	264	275	286	
	85° DB 72° WB	Low Side	79	78	78	77	77	76	76	75	75	74	73	73	73	72	72	71	71	
		High Side	118	129	140	151	162	173	184	195	206	217	229	240	250	262	273	284	295	
WPV60D	75° DB 62° WB	Low Side	59	60	61	62	63	64	65	66	67	68	69	70	71	72	73	75	76	
		High Side	90	101	112	123	134	145	156	167	178	189	200	211	222	233	244	255	266	
	80° DB 67° WB	Low Side	63	64	65	66	68	69	70	71	72	73	74	75	76	78	79	80	81	
		High Side	92	104	115	126	138	149	160	171	183	194	205	217	228	239	250	262	273	
	85° DB 72° WB	Low Side	68	69	70	71	73	74	75	76	77	79	80	81	82	83	85	86	87	
		High Side	96	107	119	131	142	154	166	177	189	201	212	224	236	248	259	271	283	

HEATING

Fluid Temperature Entering Water Coil °F

Model	Room Air Temperature	Pressure	25°	30°	35°	40°	45°	50°	55°	60°	65°	70°	75°	80°
WPV48D	70° DB	Low Side	28	32	36	40	43	47	51	54	57	61	65	69
		High Side	184	189	195	200	206	212	217	223	228	234	239	245
WPV60D	70° DB	Low Side	31	35	39	43	47	52	56	60	64	68	72	77
		High Side	214	219	225	230	236	242	247	253	258	264	269	275

Low side pressure ± 2 PSIG
High side pressure ± 5 PSIG

Tables are based upon rated CFM (airflow) across the evaporator coil and rated fluid flow rate through the water coil. If there is any doubt as to correct operation charge being in the system, the charge should be removed, system evacuated and recharged to serial plate specification.

THERMOSTAT DIAGRAMS

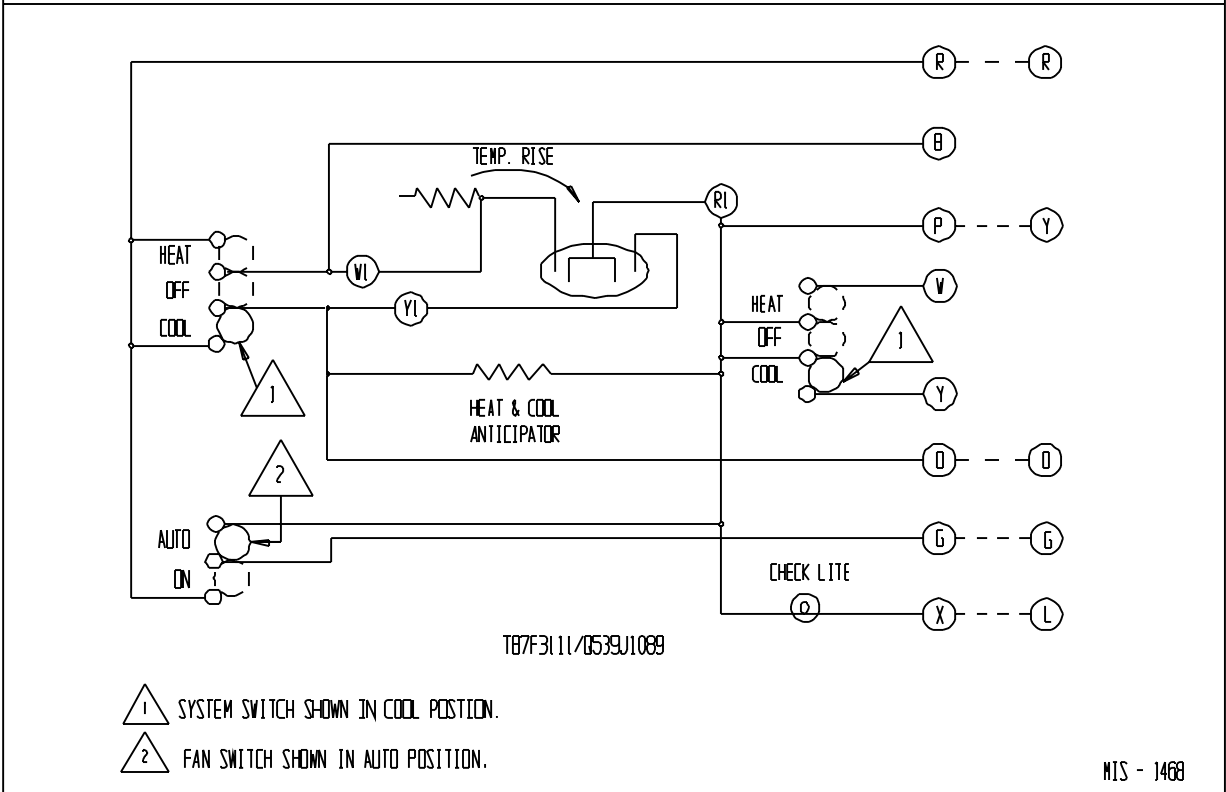
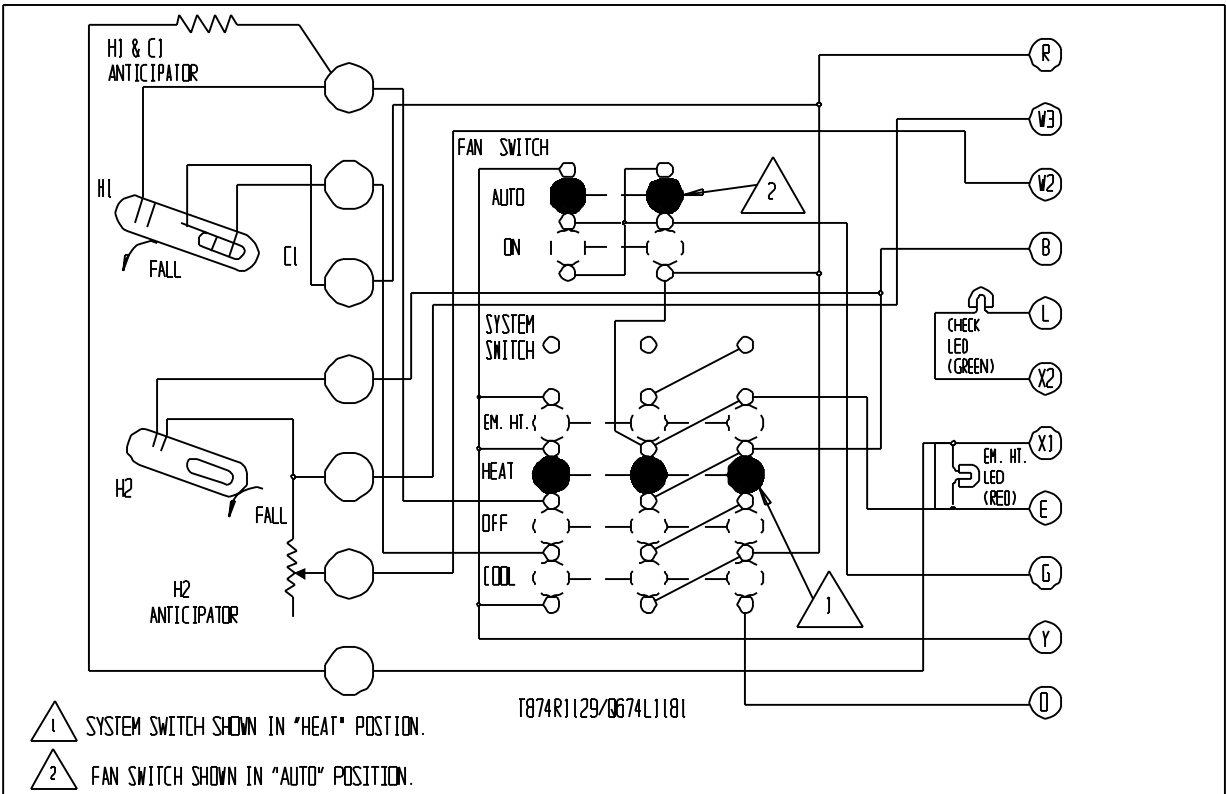

NIS - 1468

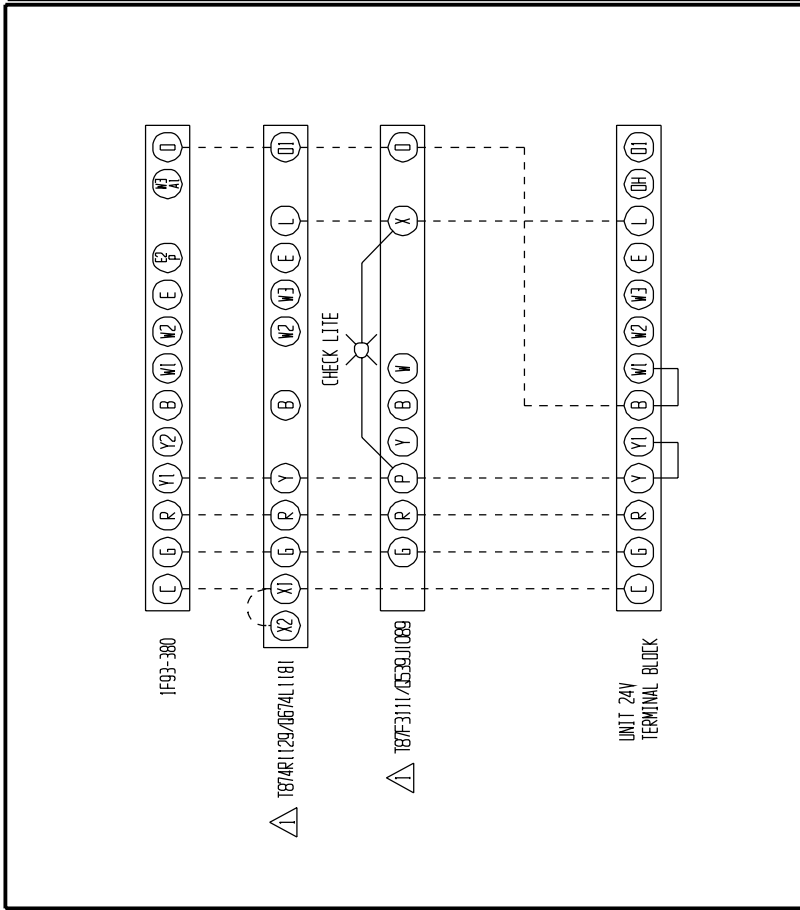

⚠ SET ADJUST HEAT ANTICIPATOR AT .45A

WATERSOURCE HEATPUMP WITHOUT
OPTIONAL DUCT HEATER

FACTORY WIRING	FIELD WIRING
LOW VOLTAGE	-----
HIGH VOLTAGE	-----

4091-810 A

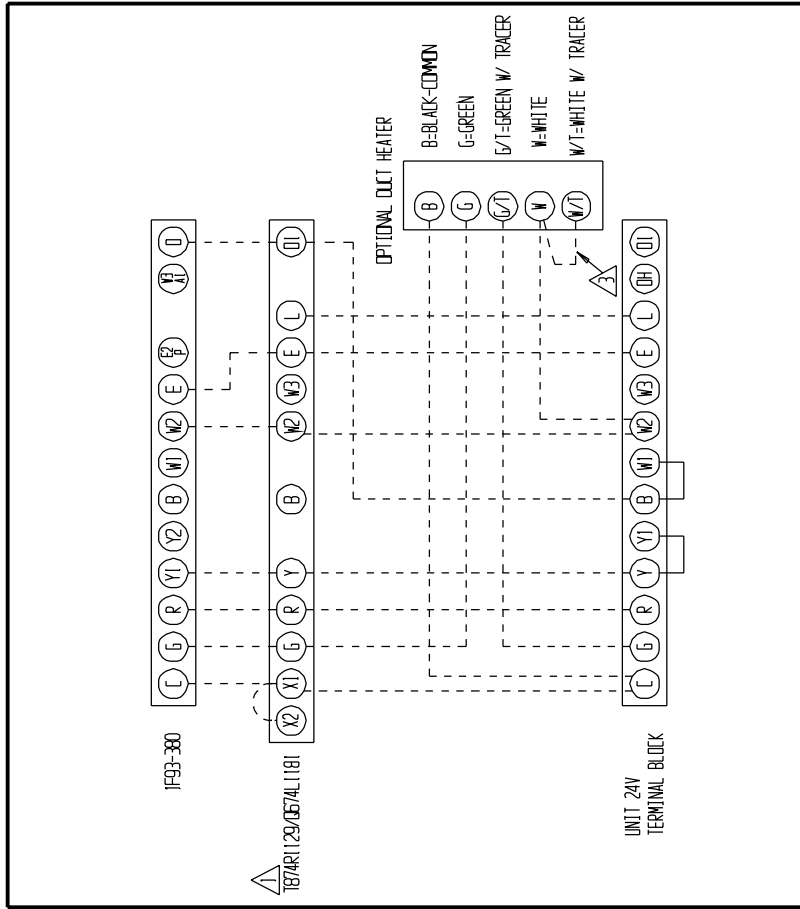

⚠ SET ADJUST HEAT ANTICIPATOR AT .45A

WATERSOURCE HEATPUMP WITH
OPTIONAL DUCT HEATER

FACTORY WIRING	FIELD WIRING
LOW VOLTAGE	-----
HIGH VOLTAGE	-----

⚠ NOT USED ON THE 5K* AND 10K* MODELS

4091-811 A

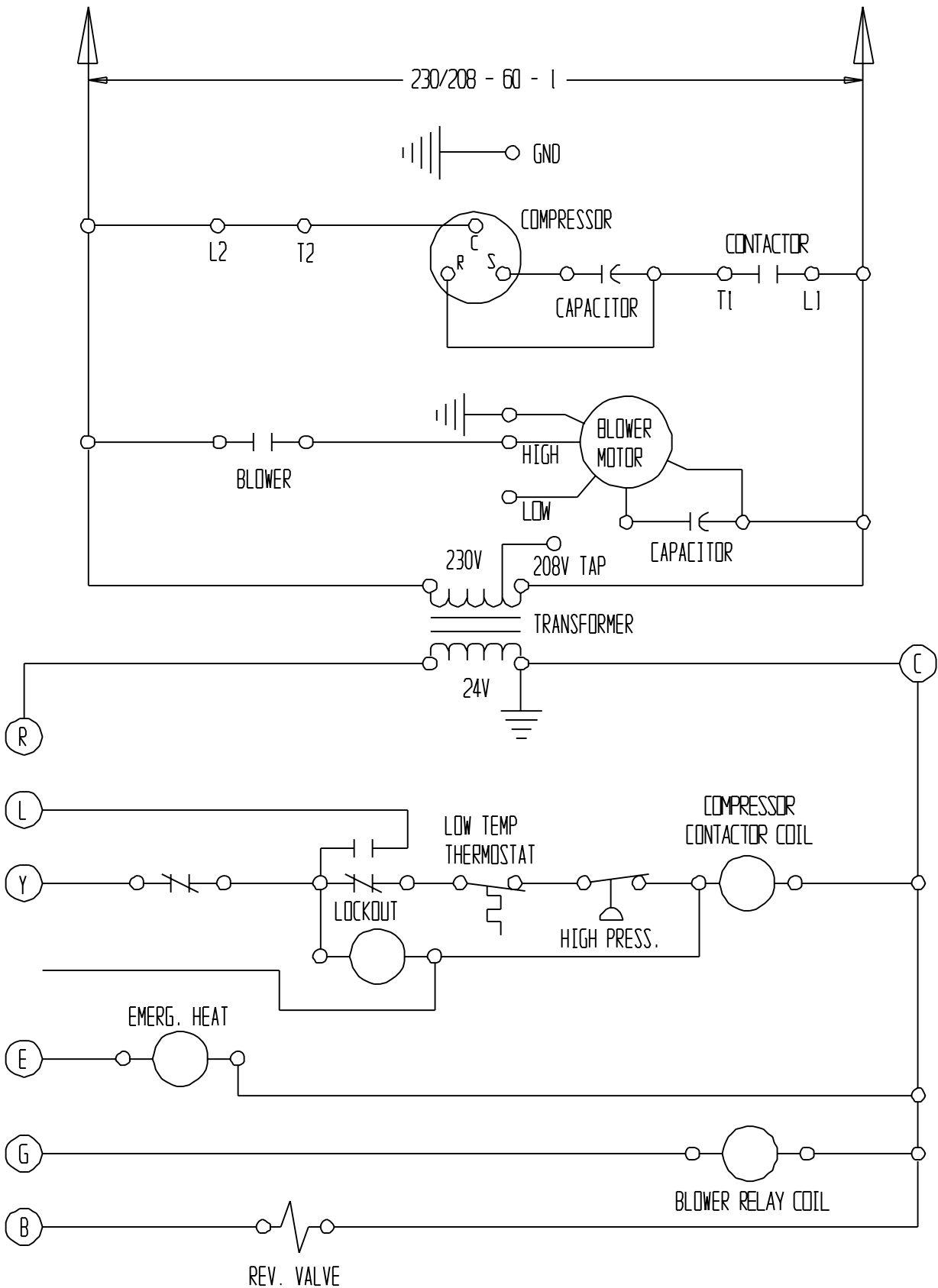

4054-813A

GROUND SOURCE HEAT PUMP PERFORMANCE REPORT

This performance check report should be filled out by installer and retained with unit.

DATE: _____ TAKEN BY: _____

1. OUTDOOR UNIT:

Mfgr. _____ Model No. _____ S/N _____

INDOOR UNIT (Split System):

Mfgr. _____ Model No. _____ S/N _____

2. Person Reporting _____

3. Company Reporting _____

4. Installed By _____ Date Installed _____

5. User's (Owner's) Name _____

Address _____

6. Unit Location _____

WATER SYSTEM INFORMATION

7. Open Loop System (Water Well) _____ Closed Loop System _____

A. If Open Loop where is water discharged? _____

8. The following questions are for Closed Loop Systems **only**

A. Closed loop system designed by: _____

B. Type of antifreeze used _____ % Solution _____

C. System type: Series _____ Parallel _____

D. Pipe Material _____ Nominal Size _____

E. Pipe Installed:

1. Horizontal _____ Total length of pipe _____ ft.

No. pipes in trench _____ Depth bottom pipe _____ ft.

2. Vertical _____ Total length of bore hole _____ ft.

THE FOLLOWING INFORMATION IS NEEDED TO CHECK PERFORMANCE OF UNIT

FLUID SIDE DATA

	Cooling	Heating	
9. Entering fluid temperature	_____	_____	F
10. Leaving fluid temperature	_____	_____	F
11. Entering fluid pressure	_____	_____	PSIG
12. Leaving fluid pressure	_____	_____	PSIG
13. Pressure drop through coil	_____	_____	PSIG
14. Gallons per minute through the water coil	_____	_____	GPM
15. Liquid or discharge line pressure	_____	_____	PSIG
16. Suction line pressure	_____	_____	PSIG
17. Voltage at compressor (unit running)	_____	_____	V
18. Amperage draw at line side of contactor	_____	_____	A
19. Amperage at compressor common terminal	_____	_____	A
20. * Suction line temperature 6" from compressor	_____	_____	F
21. * Superheat at compressor	_____	_____	F
22. * Liquid line temperature at metering device	_____	_____	F
23. * Coil Subcooling	_____	_____	F

INDOOR SIDE DATA

	Cooling	Heating	
24. Dry bulb temperature at air entering indoor coil	_____	_____	F
25. Wet bulb temperature of air entering indoor coil	_____	_____	F
26. Dry bulb temperature of air leaving indoor coil	_____	_____	F
27. Wet bulb temperature of air leaving indoor coil	_____	_____	F
28. Indoor fan motor operation voltage (split system only)	_____	_____	V
29. Indoor fan motor operating amperage	_____	_____	A
30. * Static pressure drop across indoor coil (split system only)	_____	_____	WC
31. * Supply air static pressure (packaged unit)	_____	_____	WC
32. * Return air static pressure (packaged unit)	_____	_____	WC

33. Other information about installation

* Items that are optional.