

INSTALLATION INSTRUCTIONS

TSF-80 SERIES

UPFLOW GAS FURNACES

READ ALL INSTRUCTIONS CAREFULLY BEFORE BEGINNING THE INSTALLATION.

THE INSTALLATION MUST COMPLY WITH THESE INSTRUCTIONS AND THE REQUIREMENTS OF ALL GOVERNING CODES AND ORDINANCES FOR THE INSTALLATION LOCATION.

IT IS THE RESPONSIBILITY OF INSTALLER TO KNOW AND UNDERSTAND ALL OF THESE REQUIREMENTS.

FAILURE TO DO SO COULD CREATE A HAZARD RESULTING IN PROPERTY DAMAGE, BODILY INJURY OR DEATH.

MODELS

TU044D30A TU066D36A

TU088D48A TU110D60A

TU132D60A

IMPORTANT NOTICE

THIS FURNACE IS NOT INTENDED FOR USE AS A CONSTRUCTION HEATER.

USE OF THIS FURNACE DURING CONSTRUCTION AND FINISHING PHASES OF A STRUCTURE IS CONSIDERED AS "OPERATION IN A CORROSIVE ATMOSPHERE" and "UNUSUAL, NEGLIGENT OR IMPROPER USE" AND AS SUCH ARE CONSIDERED EXCLUSIONS BY THE BARD MANUFACTURING COMPANY LIMITED WARRANTY



Manual: 2100-273A
SUPERSEDES 2100-273
FILE VOL. I, TAB 2
DATE: 04/15/96

Contents

	Page
Getting Other Information and Publications	1
1. Equipment Selection	2
2. Application	2
3. High Altitude Applications	2
4. Transportation Damage	2
5. Locating The Furnace	3
6. Duct Work	4
7. Combustion and Ventilation Air	4
8. Gas Supply and Piping	7
9. Manifold Pressure Adjustment	8
10. Checking Gas Input Rate	9
11. Derating for High Altitude	10
12. Determining Correct Orifice Size	11
13. Wiring	11
14. Flue Gas Venting	12
15. Sidewall Venting	15
16. Thermostat	16
17. Adjusting Blower Speed	20
18. Measuring Duct System Static Pressure	20
19. Measuring Air Temperature Rise	22
20. Filters	22
21. Sequence of Operation	23
22. Integrated Furnace Control (IFC)	24
23. Field Installed Electronic Air Cleaner and Humidifier	25
24. Servicing the Furnace	25
25. Maintenance Instructions	27
26. Replacement Parts	28
27. Electrical Circuit - Ladder Diagram	29
28. Wiring Diagram	30

Figures

	Page
Figure 1	4
Figure 2	5
Figure 3	6
Figure 4	6
Figure 5	6
Figure 6	7
Figure 7	8
Figure 8	14
Figure 9	14
Figure 10	14
Figure 11	14
Figure 12	15
Figure 13	16
Figure 14	17
Figure 15	18
Figure 16	19
Figure 17	21
Figure 18	23
Figure 19	23
Figure 20	26
Figure 21	26

Tables

Table 1	2
Table 2	3
Table 3	6
Table 4	7
Table 5	8
Table 6	8
Table 7	10
Table 8	11
Table 9	21
Table 10	24 & 25

Getting Other Information and Publications

These publications can help you install the furnace. You can usually find these at your local library or purchase them directly from the publisher. Be sure to consult current edition of each standard.

National Fuel Gas Code ANSI Z223.1 / NFPA 54

National Electrical Code ANSI / NFPA 70

Standard for the Installation of ANSI / NFPA 90A
Air Conditioning and Ventilating Systems

Standard for Warm Air Heating ANSI / NFPA 90B
and Air Conditioning Systems

Standard for Chimneys, Fireplaces, Vents, NFPA 211
and Solid Fuel Burning Appliances

Load Calculation for Residential ACCA Manual J
Winter and Summer Air Conditioning

Duct Design for Residential Winter ACCA Manual D
and Winter Air Conditioning and Equipment Selection

For more information, contact these publishers:

ACCA — Air Conditioning Contractors of America
1712 New Hampshire Avenue, NW
Washington, DC 20009
Telephone: (202) 483-9370

ANSI — American National Standards Institute
11 West Street, 13th Floor
New York, NY 10036
Telephone: (212) 642-4900
Fax: (212) 302-1286

**ASHRAE — American Society of Heating Refrigerating,
and Air Conditioning Engineers, Incorporated**
1791 Tullie Circle, NE.
Atlanta, GA 30329-2305
Telephone: (404) 636-8400
Fax: (404) 321-5478

NFPA — National Fire Protection Association
Batterymarch Park
P.O. Box 9101
Quincy, MA 02269-9901
Telephone: (800) 344-3555
Fax: (617) 984-7057

COPYRIGHT APRIL 1996
BARD MANUFACTURING COMPANY
BRYAN, OHIO 43506 USA

1. EQUIPMENT SELECTION

An accurate heating load calculation must be conducted using American Society of Heating, Refrigeration and Air Conditioning Engineers (ASHRAE) or Air Conditioning Contractors of America (ACCA) manuals. DO NOT add a large safety factor above the calculated value. If the calculated heating load requirement exceeds the heating capacity rating of a given model, use only the next larger size available. Never increase by any more than absolutely necessary based upon available equipment heating capacities. Always select based upon heating capacity (output), never use input capacities.

TABLE 1 – INPUT/OUTPUT CAPACITY

MODEL	INPUT BTU/HR	HEATING CAPACITY (OUTPUT) BTU/HR
TU044	44,000	35,000
TU066	66,000	53,000
TU088	88,000	70,000
TU110	110,000	88,000
TU132	132,000	106,000

2. APPLICATION

This is a fan-assisted Category I forced air gas furnace for indoor installation in building constructed on site. The furnace installation must conform with local building codes and ordinances or, in their absence with the National Fuel Gas Code ANSI Z223.1 - latest edition, and the National Electrical Code ANSI/NFPA 7- latest edition. It is the personal responsibility and obligation of the purchaser to contact a qualified installer to assure that installation is adequate and is in conformance with governing codes and ordinances.

* IMPORTANT NOTICE *

THIS FURNACE IS NOT INTENDED FOR USE AS A CONSTRUCTION HEATER.

USE OF THIS FURNACE DURING CONSTRUCTION AND FINISHING PHASES OF A STRUCTURE IS CONSIDERED AS "OPERATION IN A CORROSIVE ATMOSPHERE" AND "UNUSUAL, NEGLIGENT OR IMPROPER USE" AND AS SUCH ARE CONSIDERED EXCLUSIONS BY THE BARD MANUFACTURING COMPANY LIMITED WARRANTY.

When a furnace is used as a construction heater, it is operated under unusual and abnormal conditions that can cause condensation to occur in the furnace and/or vent system on TU series that will not condense under normal operation conditions when properly sized, installed and setup for operation.

Combined with condensation problems are the many sources of chloride that are present in high concentrations during construction phases of a structure. These chloride sources are either very reduced or the vapors have left once the construction activities are completed and the structure is ready to occupy.

Many of the more common construction sources of chlorides are listed below, and they are usually present in large quantities:

Cement/Concrete Mixtures	Tile/Counter Cements
Paint	Adhesives
Stain, Varnish	Cements and Glues
Solvents	Dust Particles
Wood Preservatives	Foam Insulation
Floor Sealers	

When this furnace is used in connection with a cooling unit, the furnace shall be installed parallel with or on the upstream side of the cooling unit to avoid condensation in the heat exchanger. In a parallel flow application, the means used to control flow of air shall be adequate to prevent chilled air from entering the furnace. If manually operated, there must be a means to prevent operation of either unit unless the control is in the full heat or cool position.

3. HIGH ALTITUDE APPLICATIONS

Ratings of gas utilization equipment are based on sea level operation and need not be changed for operation at elevations up to 2,000 feet. For operation at elevations above 2,000 feet and, in the absence of specific recommendations from the local authority having jurisdiction, equipment ratings shall be reduced at the rate of 4 percent for each 1,000 feet above sea level before selecting appropriately sized equipment. [Ref. ANSI Z223.1 (NFPA54), latest edition]. See Table 7.

4. TRANSPORTATION DAMAGE

All units are packed securely in shipping container. All units should be carefully inspected upon arrival for damage. In the event of damage, the consignee should:

1. Note on delivery receipt of any damage to container.
2. Notify carrier promptly, and request an inspection.
3. In case of concealed damage, the carrier must be notified as soon as possible within 15 days after delivery.
4. Claims for any damage, apparent or concealed, should be filed with the carrier, using the following supporting documents:
 - A. Original Bill of Lading, certified copy, or indemnity bond.

- B. Original paid freight bill of indemnity in lieu thereof.
- C. Original invoice or certified copy thereof showing trade and other discounts or deductions.
- D. Copy of the inspection report issued by carrier's representative at the time damage is reported to carrier.

The carrier is responsible for making prompt inspection of damage and for a thorough investigation of each claim.

5. LOCATING THE FURNACE

When selecting a location for the furnace, observe the following points:

1. The furnace should be set on a level floor. If the floor may become damp or wet at times, the furnace should be supported above the floor using a concrete base, bricks, patio blocks, etc., making sure adequate support is available for the furnace. Furnaces approved for installation on combustible flooring shall not be installed directly on carpeting, tile or other combustible material other than wood flooring.
2. The furnace should be as centralized as practical with respect to the air distribution system.
3. Provisions must be made for venting combustion products outdoors through an individual venting system.
4. Provide at least the minimum clearance specified in Table 2 for fire protection, proper operation and service access. These clearances must be permanently maintained. The combustion and ventilating air openings in front of the furnace must never be obstructed.
5. This furnace must be installed as to protect all electrical components from exposure to condensation and/or water.
6. Minimum service clearances must take precedence over fire protection clearances (minimum installation clearances).
7. All models are approved for a utility room or closet installation.
8. A gas-fired furnace installed in a residential garage must be installed so that the burners and ignition source are located not less than 18 inches above the floor, and the furnace must be located or protected to avoid physical damage by vehicles.

Table 2 — Minimum Clearances – Inches

Model	Minimum Installation Clearances									Minimum Service Clearances			Minimum Ventilation Openings for Confined Spaces – Square Inches of Free Area (1)
	Furnace				Plenum		Duct	Vent Pipe	Floor	Front	Back	Sides	
	Front	Back	Left Side	Right Side	Top	Sides							
TU044	6	0	0	2**	0	0	0	6*	C	24	0	0	100 (2 required)
TU066	6	0	0	0	0	0	0	6*	C	24	0	0	100 (2 required)
TU088	6	0	0	0	0	0	0	6*	C	24	0	0	100 (2 required)
TU088	6	0	0	0	0	0	0	6*	C	24	0	0	110 (2 required)
TU132	6	0	0	0	0	0	0	6*	C	24	0	0	132 (2 required)

(1) See Section 7 - Combustion & Ventilation Air for additional details

C – Floor may be combustible material

* Clearance may be 1 inch when Type B-1 vent is used

** Clearance may be 0 inch Type B-1 vent is used

6. DUCT WORK

Adequate Supply Air and/or Return Air Duct System

Short cycling because of limit control operation can be created by incorrectly designed or installed supply and/or return air duct system.

The duct systems must be designed using ASHRAE or ACCA design manuals and the equipment cfm and external static pressure ratings to insure proper air delivery capabilities.

On replacement installations, particularly if equipment is oversized, the duct systems can easily be undersized. *Modifications may be required to assure that the equipment is operating within the approved temperature rise range when under full input conditions, and that no short cycling on limit controls is occurring.*



WARNING

When a furnace is installed so that supply ducts carry air circulated by the furnace to areas outside the space containing the furnace, the return air must also be handled by a duct(s) sealed to the furnace casing and terminating outside the space containing the furnace. Failure to do this could permit hazardous combustion products being drawn into the circulation air resulting in fire, nausea, or asphyxiation. See Figure 1.

For installation of furnace *not* equipped with cooling units*, the outlet duct must be provided with a removable access panel. This opening must be accessible after the furnace is installed and shall be of such a size that the heat exchanger can be inspected for possible leaks. The access panel must be attached in a manner to prevent leakage.

* A cooling unit is an air conditioning coil, heat pump coil or chilled water coil.

7. COMBUSTION AND VENTILATION AIR

The furnace and furnace room must have an adequate supply of air for safe combustion and ventilation. The provisions necessary to assure an adequate air supply will vary depending upon differences in the tightness of house construction and in the location of the furnace. Methods of providing air from some typical situations are described on Page 5 & 6. Consult local codes and ordinances for requirements applicable to your specific furnace installation conditions and comply with them. In the absence of local codes and ordinances, comply with the National Fuel Gas Code, ANSI Z223.1 (NFPA 54), latest edition.

FIGURE 1

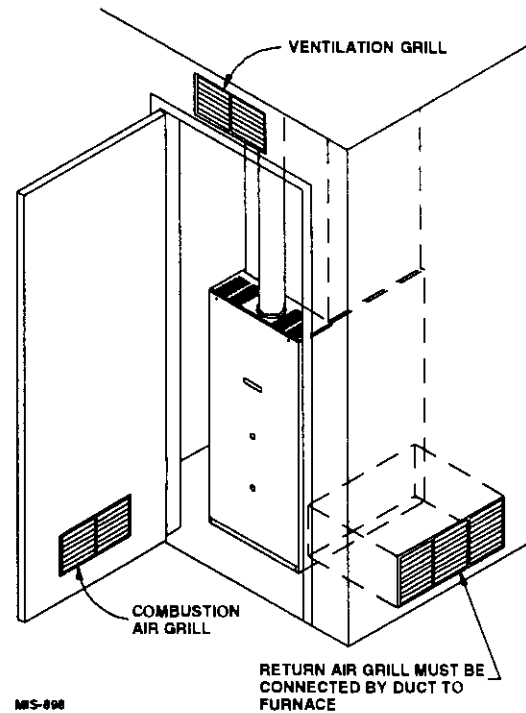

SAMPLE LISTING OF CONTAMINANTS TO BE AVOIDED

The recommended source of combustion air is to use the outdoor air supply options indicated on Page 6. However, the use of indoor air in most applications is acceptable if these guidelines are followed:

1. If the furnace is installed in a confined space, the necessary combustion air must come from the outdoors by way of attic, crawl space, air duct or direct opening.
2. If indoor combustion air option is used, there must be no exposure to the installations or substances listed below.
3. All provisions for indoor combustion air must meet the requirements for combustion air supply indicated in the National Fuel Gas Code, Z223. (NFPA 54), latest edition.
4. The following types of installation will require *OUTDOOR AIR* for combustion due to chemical exposures:
 - Commercial buildings
 - Buildings with indoor pools
 - Furnaces installed in laundry rooms
 - Furnaces installed in hobby or craft rooms
 - Furnaces installed near chemical storage areas

Exposure to the following substances in the combustion air supply will also require *OUTDOOR AIR* for combustion:

- Permanent wave solutions
- Chlorinated waxes and cleaners
- Chlorine based swimming pool chemicals
- Water softening chemicals
- Deicing salts or chemicals
- Carbon tetrachloride
- Halogen type refrigerants
- Cleaning solvents (such as perchloroethylene)
- Printing inks, paint removers, varnishes, etc.
- Hydrochloric acid
- Cements and glues
- Antistatic fabric softeners for clothes dryers
- Masonry acid washing materials
- Chlorine bleach.



WARNING

Combustion air that contains chlorine, fluorine, bromine or iodine could cause corrosion in heat exchanger or vent system, resulting in nausea or death by asphyxiation.

EQUIPMENT LOCATED IN UNCONFINED SPACES

The National Fuel Gas Code, ANSI Z223.1 / NFPA 54 does not require that you make special provisions for combustion and ventilation when furnace is in an "unconfined space" and the building is not of "unusually tight construction".

- "Unconfined spaces" have a volume of at least 50 cubic feet per 1000 Btu per hour combined input rating of all appliances installed in the space. For example: a 88,000 Btu/hr furnace and a 30,000 Btu/hr water heater would require a volume of at least $118,000 \times 50 \div 1,000$ or 5,900 cubic feet.
- "Unusually tight construction" means windows and doors are either tight fitting or are sealed construction and the walls are covered with a continuous, sealed vapor barrier and drywall or similar materials having sealed joints.

If you meet the volume requirements for unconfined space, the building is not of unusually tight construction and there are no airborne contaminants, as listed above, you may install this furnace without making special provisions for combustion and ventilation. Otherwise, follow the instructions for "confined space installation" below.

EQUIPMENT LOCATED IN CONFINED SPACES

A furnace installed in a confined space may take combustion and ventilation air from an unconfined space within the building or from outdoors. However, if the building is of unusually tight construction all combustion air must come from outdoors. Also, if return air is taken directly from a hallway or space next to furnace that communicates with furnace spaces, all combustion air must come from outdoors.



WARNING

You must provide permanent air openings to a confined furnace installation space from another area. Failure to do so could result in inadequate combustion and ventilation air.

A. All Air From Inside The Building

The confined furnace space must be provided with two permanent openings to an additional room of sufficient volume so that the combined volume of the spaces meet the criteria from page 4 for an unconfined space not of unusually tight construction. The total input of all gas appliances within the combined space must be considered in making this determination.

Each opening must have minimum free area of one square inch per 1,000 Btu per hour of the total combined input rating of all gas appliances within the confined furnace space, but not less than 100 square inches. One opening must be within 12 inches of the top of the furnace space. The shortest side of each air opening must be at least 3 inches long. See Figure 1.

For example:

- A 88,000 Btu/hr furnace and a 30,000 Btu/hr water heater would require free area openings of $118,000 \div 1,000$ or 118 square inches each.
- A 44,000 Btu/hr furnace would require free area openings of 100 square inches each.

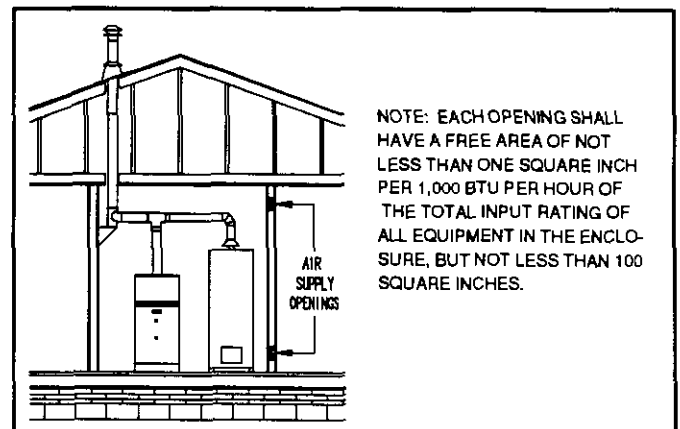

FIGURE 2 – CONFINED SPACE, ALL AIR FROM INSIDE THE BUILDING

B. All Air From Outdoors

The furnace space must be provided with two permanent air openings communicating directly, or by ducts, with the outdoors or spaces that freely access the outdoors. Well ventilated attics or crawl spaces usually satisfy this requirement. These openings will give the furnace free access to fresh air for combustion and ventilation.

You must provide air sufficient for all gas appliances within furnace space. Locate one combustion and ventilation air opening within 12 inches of top of furnace space. Locate another within 12 inches of bottom of furnace space.

Ducts which supply air from outdoors must have the same cross-sectional area as the free area of openings to which they connect.

When directly communicating with the outdoors, each opening must have a minimum free area of one square inch per 4,000 Btu per hour of total combined input rating of all gas appliances within furnace space. For example: A 100,000 Btu per hour furnace requires two openings of at least $100,000 \div 4,000$ or 25 square inches. See Figure 3 and Table 3.

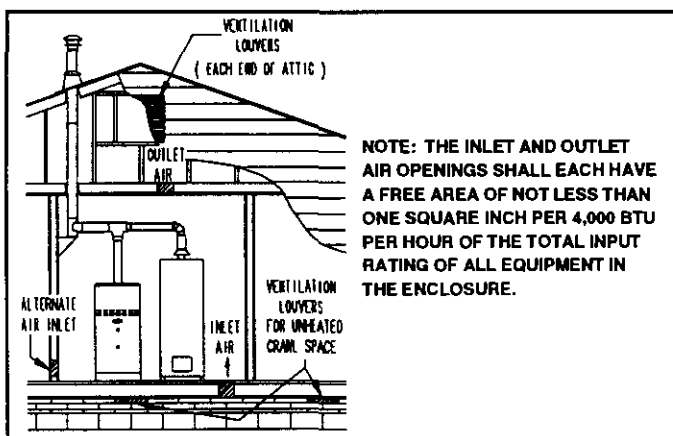

FIGURE 3 – ALL AIR DIRECTLY FROM SPACES THAT FREELY ACCESS THE OUTDOORS

When communicating with the outdoors through vertical ducts, such openings and ducts must have a minimum free area of one square inch per 4,000 Btu per hour of total combined input rating of all gas appliances within furnace space. See Figure 4 and Table 3.

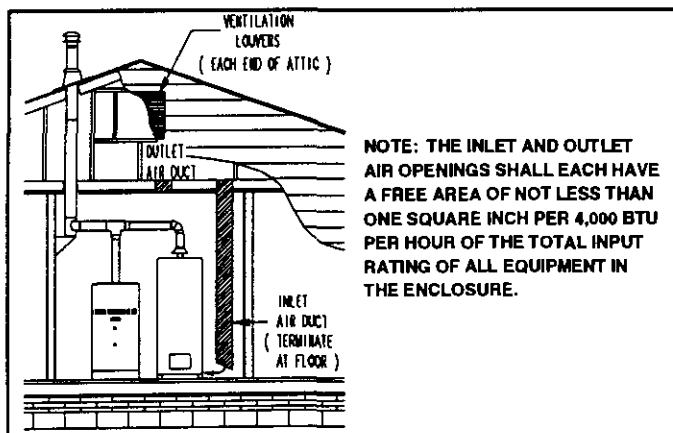

FIGURE 4 – ALL AIR THROUGH VERTICAL DUCTS FROM SPACES THAT FREELY ACCESS THE OUTDOORS

TABLE 3 – FREE OPENING AREA BASED ON ONE SQUARE INCH PER 4000 BTU/HR

Total input Btu/hr	Required Free Area per Opening (square inches)	Minimum Round Pipe (inches dia.)	Maximum Btu/hr Input For Given Pipe Diameter
40,000	10	4	50,000
60,000	15	5	78,000
80,000	20	6	113,000
100,000	25	6	113,000
120,000	30	7	153,000
140,000	35	7	153,000
160,000	40	8	201,000
180,000	45	7	201,000

When communicating with the outdoors through horizontal ducts, such openings and ducts must have a minimum free area of one square inch per 2,000 Btu per hour of total combined input rating of all gas appliances within furnace space. See Figure 5 and Table 4.

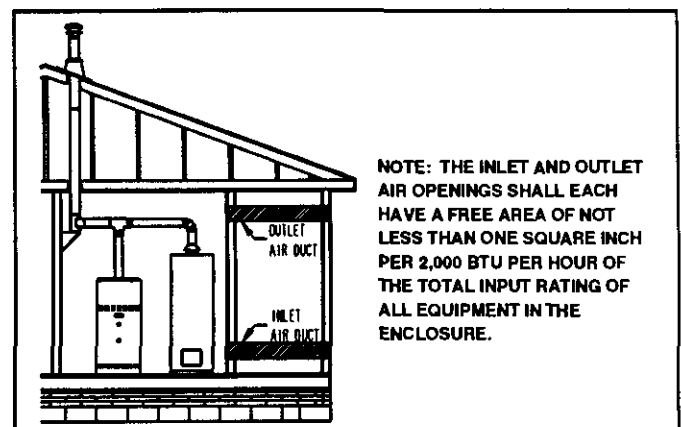

FIGURE 5 – ALL AIR FROM THE OUTDOORS THROUGH HORIZONTAL DUCTS.

TABLE 4—FREE OPENING AREA BASED ON ONE SQUARE INCH PER 2000 BTU/HR

Total Input Btu/hr	Required Free Area Per Opening (square inches)	Minimum Round Pipe (inches dia.)	Maximum Btu/hr Input for Given Pipe Diameter
40,000	20	6	56,000
60,000	30	7	76,000
80,000	40	8	100,000
100,000	50	8	100,000
120,000	60	9	127,000
140,000	70	10	157,000
160,000	80	11	190,000
180,000	90	11	190,000

Example: Furnace is 100,000 Btu per hour input and is to be installed in a confined space that contains no other gas appliances. Rectangular combustion and ventilation air ducts will run horizontally from outdoors to furnace space.

Calculate the free area required.

Because combustion and ventilation air ducts run horizontally, allow 2,000 Btu per hour.

$$\frac{\text{Furnace input (Btu/hr)}}{2000 \text{ Btu/hr per square inch}} = \text{Free area required}$$

$$\frac{100,000}{2,000} = 50 \text{ square inches}$$

LOUVERS, GRILLES AND SCREENS

If you are installing a louver, grille or screen over combustion and ventilation air openings, the free area of the louver or grille must be at least as big as the free area determined above. Louver, grille and screen manufacturers supply technical data which usually includes the "free area". If you do not know the free area, assume that wood louvers have 20 to 25% free area. Assume metal louvers and grilles have 60 to 70% free area.

You must fix combustion and ventilation air louvers and grilles in the open position or interlock them with furnace operation so that they open automatically. Do not use screen smaller than 1/4 inch mesh.

8. GAS SUPPLY AND PIPING

GENERAL RECOMMENDATIONS

1. Be sure the gas line complies with the local codes and ordinances, or in their absence with the National Fuel Gas Code, ANSI Z223.1 - latest edition.
2. A sediment trap or drip leg must be installed in the supply line to the furnace.
3. A ground joint union shall be installed in the gas line adjacent to and upstream from the gas valve and downstream from the manual shut-off valve.
4. An 1/8" NPT plugged tapping accessible for test gauge connection shall be installed immediately upstream of the gas supply connection to the furnace for the purpose of determining the supply gas pressure. This can be omitted if local codes permit use of plugged tapping in gas valve inlet.
5. Install A.G.A. listed manual shut-off valve in the supply gas line external to and immediately upstream of the furnace. See Figure 6.
6. Use steel or wrought iron pipe and fittings.
7. **DO NOT** thread pipe too far. Valve distortion or malfunction may result from excess pipe within the control. Use pipe joint compound resistant to the action of liquefied petroleum gases on male threads only. **DO NOT** use Teflon tape. See Table 5 and Figure 7.

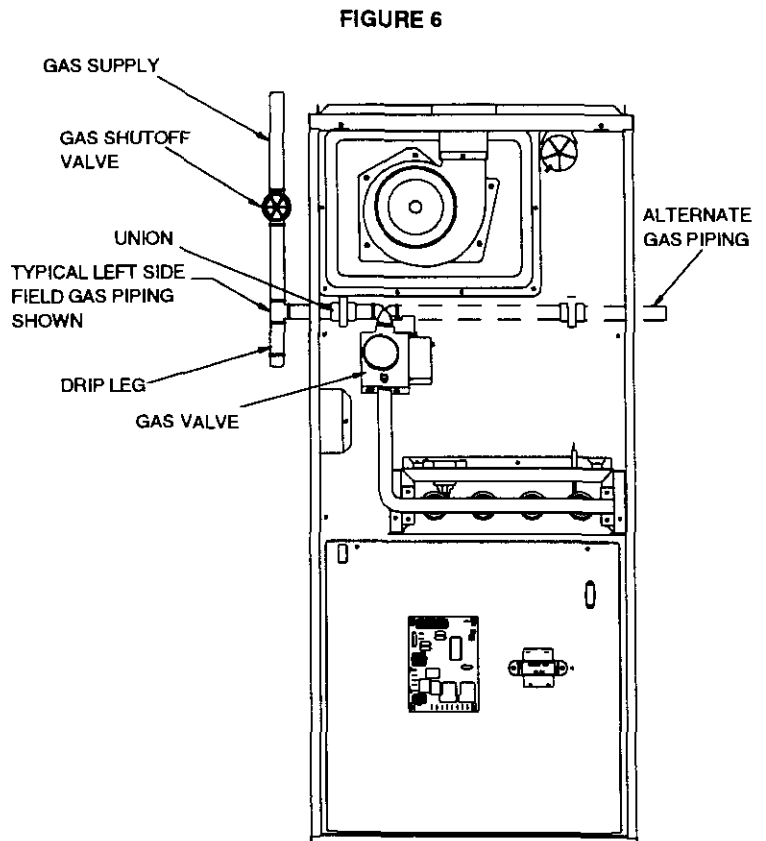

FIGURE 6

W15-952

TABLE 5 - LENGTH OF STANDARD PIPE THREADS (Inches)

Pipe Size	Effective Length of Thread	Overall Length of Thread
3/8	1/2	9/16
3/4	1/2 - 9/16	13/16
1	9/16	1

FIGURE 7

PROPER PIPING PRACTICE

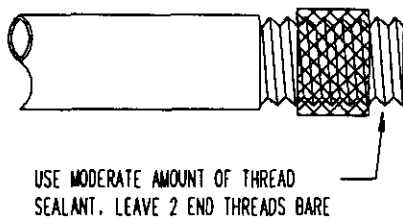

MIS-867

- Refer to Table 6 for Gas Pipe Sizes for natural gas. If more than one appliance is supplied from a single line size, capacity must equal or exceed the combined input to all appliances, and the branch lines feeding the individual appliances properly sized for each input.

TABLE 6 - GAS PIPE SIZES - NATURAL GAS

Length of Pipe - Feet	Pipe Capacity - BTU Per Hour Input Pipe Size			
	1/2"	3/4"	1"	1-1/4"
10	132,000	278,000	520,000	1,050,000
20	92,000	190,000	350,000	730,000
30	73,000	152,000	285,000	590,000
40	63,000	130,000	245,000	500,000
50	56,000	115,000	215,000	440,000
60	50,000	105,000	195,000	400,000
70	46,000	96,000	180,000	370,000
80	43,000	90,000	170,000	350,000
100	38,000	79,000	150,000	305,000

CHECKING THE GAS PIPING

Before turning gas under pressure into piping, all openings from which gas can escape should be closed. Immediately after turning on gas, the system should be checked for leaks. This can be done by watching the 1/2 cubic foot test dial and allowing 4 minutes to show any movement, and by soaping each pipe connection and watching for bubbles. If a leak is found, make the necessary repairs immediately and repeat the above test. The furnace must be isolated from the gas supply piping system by closing the manual shut-off valve on the combination gas control valve during pressure testing of the gas supply piping system at

pressures up to 1/2 PSIG. The furnace and its individual shut-off valve must be disconnected from supply piping and supply piping capped during any pressure testing of supply piping system at test pressures in excess of 1/2 PSIG.

Defective pipes or fittings should be replaced and not repaired. Never use a flame or fire in any form to locate gas leaks; use a soap solution.

After the piping and meter have been checked completely, purge the system of air. **DO NOT** bleed air inside the furnace. Be sure to check and relight all the gas pilots on other appliances that may have been extinguished because of interrupted gas supply.

9. MANIFOLD PRESSURE ADJUSTMENT

You will need a 0 to 15 inch water manometer with 0.1 inch resolution and a 1/8" NPT manual shut-off valve to measure actual manifold pressure.

WARNING

Correct manifold pressure is necessary for proper ignition and burner operation. Failure to accurately adjust pressure could cause heat exchanger failure.

- Turn off gas at equipment shut-off valve in gas supply line just ahead of furnace.
- Remove plug from outlet pressure tap in gas control.
- Install 1/8" NPT manual shut-off valve in hole vacated by plug. Make sure shut-off valve is in off position.
- Attach manometer to 1/8" NPT manual shut-off valve just installed.
- Slowly open equipment shut-off valve in gas supply line just ahead of furnace. Start furnace following "Operating Instructions" on front door.
- Slowly open 1/8" NPT manual shut-off valve leading to manometer.
- Read manifold pressure on manometer.
- Adjust manifold pressure by turning gas control regulator adjusting screw clockwise to increase pressure or turning counterclockwise to decrease pressure. Manifold pressure must be within allowable range below:

- Natural gas manifold pressure must be between 3.2 and 3.8 inches W.C.
- Propane gas (LP) manifold pressure must be between 9.7 and 10.3 inches W.C.

NOTE: For natural gas, if gas flow rate can't be properly set within these pressure ranges then you must change main burner orifices to obtain proper gas flow rate.

9. Shut off furnace. Turn off gas at equipment shut-off valve in gas supply line just ahead of furnace. Install outlet pressure tap plug in gas control. Turn on gas.
10. Check regulator adjustment cover screw and gas control plug for gas leaks. Use a commercial soap solution made for leak detection.

10. CHECKING GAS INPUT RATE

It is the installer's responsibility to see that the Btu input rate of the furnace is properly adjusted. Under-firing could cause inadequate heat, excessive condensation or ignition problems. Over-firing could cause sooting, flame impingement or overheating of heat exchanger.

 <h1 style="margin: 0; display: inline;">WARNING</h1>
<p>Failure to adjust furnace to the proper firing rate could cause heat exchanger failure.</p>

Depending on your local gas heating value and elevation, you may need to adjust manifold pressure or change orifices to get proper gas input rate. Check with your local gas supplier to determine heating value (Btu/cu. ft.) of natural gas in your area.

NOTE: If furnace is being installed at an altitude of more than 2000 feet above sea level, you must derate the furnace. See Section 11, "Derating For High Altitude".

NATURAL GAS INPUT RATE

Natural gas heating value (Btu/cu. ft.) can vary significantly. Before starting natural gas input check, obtain gas heating value at your location from local supplier. You will need a stopwatch to measure actual gas input.

1. Gas supply pressure must be between 5 and 7 inches W.C. for natural gas.
2. Turn off all other gas appliances. You may leave pilots on.
3. Start furnace following "Operating Instructions" on front door.
4. Let furnace warm up for 6 minutes.
5. Locate gas meter. Determine which dial has the least cubic feet of gas and how many cubic feet per revolution it represents. This is usually one-half, one or two cubic feet per revolution.

6. With stopwatch, measure time it takes to consume two cubic feet of gas.
 - If dial is one-half cubic foot per revolution, measure time for four revolutions.
 - If dial is one cubic foot per revolution, measure time for two revolutions.
 - If dial is two cubic feet per revolution, measure time for one revolution.
7. Divide this time by two. This gives average time for one cubic foot of gas to flow through meter. Example: If it took 58 seconds for two cubic feet to flow, it would take 29 seconds for one cubic foot to flow.
8. Calculate gas input using this formula:

$$\text{Gas input} = \frac{\text{Gas Heating Value (Btu/cu. ft.)} \times 3,600 \text{ sec/hr}}{\text{Time (Seconds for one cubic foot of gas)}} = \text{Btu/hour}$$

Example:

Assume it took 29 seconds for one cubic foot of gas to flow and heating value of 1,000 Btu/cu. ft.

$$\text{Gas input} = \frac{1,000 \times 3,600}{29} = 124,138 \text{ Btu per hour}$$

If you left no other pilots on, this is the furnace gas input.

9. If you left water heater, dryer or range pilots on, allow for them in calculating correct furnace gas input. A quick way is to allow 1,000 Btu per hour for a water heater, 500 Btu per hour for dryer and 500 Btu per hour for each range burner pilot.

Example:

If you left gas water heater, dryer, two range burner pilots and one oven pilot on, allow:

Water heater pilot	1,000 Btu per hour
Dryer pilot	500 Btu per hour
2 range burner pilots	1,000 Btu per hour
1 range oven pilot	500 Btu per hour
	3,000 Btu per hour

Subtracting 3,000 Btu per hour from 124,138 Btu per hour measured above equals 121,138 Btu per hour. This would be the correct furnace gas input after allowing for pilots left on.

10. Manifold pressure may be adjusted within the range of 3.2 inches W.C. to 3.8 inches W.C. to get rated input \pm 2 percent. See Section 9, "Manifold Pressure Adjustment". If you cannot get rated input with manifold pressure within the allowable range, you must change orifices.

PROPANE (LP) GAS INPUT RATE

⚠ WARNING

Propane (LP) gas installations do not have gas meters to double check input rate. Measure manifold pressure adjustment with an accurate manometer. Failure to accurately adjust pressure could cause heat exchanger failure, asphyxiation, fire or explosion, resulting in damage, injury or death.

1. Make sure you have main burner orifices.
2. Gas supply pressure must be between 11 and 13 inches W.C. for propane (LP) gas.
3. Start furnace following "Operating Instructions" on front door.
4. Let furnace warm up for 6 minutes.
5. Adjust manifold pressure to 10.0 W.C. ± 0.3 inches W.C. See Section 9, "Manifold Pressure Adjustment".

⚠ WARNING

Do not set Propane (LP) manifold pressure at 11.0 inches W.C. It could cause heat exchanger failure.

11. DERATING FOR HIGH ALTITUDE

At higher altitudes, the density of the air is reduced. Therefore, for proper combustion, the quantity of gas burned in the furnace must also be reduced. This is called derating. Furnaces must be derated when installed at altitudes greater than 2,000 feet above sea level.

Derating the furnace by adjusting the manifold pressure lower than the range specified in the Section 9, "Manifold Pressure Adjustment" is considered to be an improper procedure.

At elevations above 2,000 feet, the furnace must be derated 4% for each 1,000 feet above sea level. It is the installers responsibility to see that the furnace input rate is adjusted properly. Derating must be achieved by reducing the size of the main burner orifices. Choose the proper orifices for your altitude and gas heating value from Orifice Size Table 7.

TABLE 7 – ORIFICE SIZE

Gas Type	Gas Btu Content	ELEVATION, FEET ABOVE SEA LEVEL								
		0-2000	3000	4000	5000	6000	7000	8000	9000	10000
Natural	800	39	2.45	2.40	3/32	2.30	2.30	43	2.20	2.15
Natural	825	2.50	2.40	3/32	2.35	2.30	43	2.20	2.15	2.10
Natural	850	2.45	3/32	2.35	2.30	43	2.20	44	2.15	2.10
Natural	875	2.40	2.30	2.30	43	2.20	2.20	2.15	2.10	46
Natural	900	2.40	2.30	43	2.25	2.20	2.15	2.10	45	2.00
Natural	925	2.35	43	2.25	2.20	2.15	2.10	2.10	46	2.00
Natural	950	2.30	2.25	2.20	44	2.15	2.10	46	2.00	5/64
Natural	975	2.30	2.20	44	2.15	2.10	45	2.05	2.00	1.95
Natural	1000	43	44	2.15	2.10	2.10	46	2.00	1.95	48
Natural	1025	2.25	2.15	2.10	2.10	46	2.00	2.00	1.95	1.90
Natural	1050	2.20	2.10	2.10	45	2.05	2.00	1.95	48	49
Natural	1075	44	2.10	45	46	2.00	5/64	1.95	1.90	49
Natural	1100	2.15	45	46	2.00	2.00	1.95	48	49	1.80
Propane	2500	54	1.35	55	1.30	1.25	1.25	1.20	1.20	56

NOTE: Two digit numbers are Number Drills: example 44
 Three digit numbers with two decimal places are Metric Drills: example 2.30mm
 Numbers shown as fractions are Fractional Drills: example 5/64

12. DETERMINING CORRECT ORIFICE SIZE

These furnaces are shipped with fixed gas orifices for use with Natural Gas and sized for 1000 Btu/cubic foot gas. Make sure actual furnace gas input does not exceed furnace rating plate input. You may need to change orifices to get correct gas input. Whether you do or not depends on furnace input, your gas heat value at standard conditions, and elevation. Consult your local gas supplier for gas heat, value and any special derating requirements. Table 7 gives orifice specifications based upon standard conditions shown.

For propane (L.P.) gas operation, the furnace must be converted using authorized L.P. kit, CKPG-1, sold separately.

13. WIRING

WARNING

For your personal safety, turn off electric power at service entrance panel before making any electrical connections. Failure to do so could result in electric shock or fire.

All electrical work must conform with local codes and ordinances or, in their absence, with the National Electrical Code, ANSI/NFPA 70, latest edition.

ELECTRICAL POWER SUPPLY

Run a separate 120 volt AC circuit from a separate fuse or circuit breaker in the service entrance panel with an ampacity rating per Table 8. Locate a shut-off switch at the furnace. Make connections from this switch to the furnace junction box as shown in the furnace wiring diagram.

WARNING

Failure to provide an electrical power supply shut-off means could result in electric shock or fire.

ELECTRICAL GROUNDING

When installed, the furnace must be electrically grounded in accordance with local codes or in the absence of local codes, with the National Electrical Code, ANSI/NFPA 70, latest edition. Use a #14 AWG cooper wire from green ground wire on the furnace to a grounded connection in the service panel or a properly driven and electrically grounded ground rod.

WARNING

Failure to provide a proper electrical ground could result in electric shock or fire.

FIELD INSTALLED EQUIPMENT

Wiring to be done in the field between the furnace and devices not attached to the furnace, or between separate devices which are field installed and located, shall conform with the temperature limitation for Type T wire {63 degrees F rise (36 degrees C)} when installed in accordance with the manufacturer's instructions. Refer to wiring diagram on Page 30.

TABLE 8 – AMPACITY RATING

MODEL	VOLTS/HZ/PH	TOTAL AMPS	BLOWER MOTOR		INDUCER MOTOR		MINIMUM CIRCUIT AMPACITY	MAXIMUM TIME DELAY FUSE OR HACR CIRCUIT BREAKER
			HP	FLA	HP	FLA		
TU044	115/60/1	9.25	1/3	4.5	1/40	1.0	15	15AMP
TU066	115/60/1	11.3	1/3	6.5	1/40	1.0	15	15AMP
TU088	115/60/1	15.3	1/2	10.5	1/40	1.0	15	15AMP
TU110	115/60/1	17.3	3/4	12.5	1/40	1.0	16	20AMP
TU132	115/60/1	17.3	3/4	12.5	1/40	1.0	16	20AMP

14. FLUE GAS VENTING

This furnace must be connected to a venting system adequate to remove flue and vent gasses to the outside atmosphere. It must be vented in accordance with Part 7, Venting Equipment, of the National Fuel Gas Code ANSI Z223.1. It must also be vented in accordance with local building codes and vent manufacturer's instructions.

The furnaces covered by this manual are design-certified as Category I appliances. Category I appliances operate at negative vent static pressure with a vent gas temperature high enough to avoid condensation in the vent. Category I appliances rely on the buoyancy of combustion products to vent. Category I furnaces may be common vented.

In most cases, proper venting is achieved by using a conventional vertical vent or chimney. However, it is not uncommon to have an installation where venting through a sidewall becomes necessary. For information on venting through a sidewall using a mechanical (power) venter, see Section 15, "Sidewall Venting". This furnace must not be vented with plastic pipe.

To supplement national and local codes, instructions for venting as Category I are contained in this manual.

DEFINITIONS

"Vent" and "chimney" refer to open passageways which convey vent gases from the furnace, or its vent connector, to the outside. Vents and chimneys usually run vertically or nearly vertical. When they serve only one gas appliance, they are called "dedicated" vents or chimneys. When they serve multiple gas appliances, they are called "common" vents or chimneys.

"Vent Connector" refers to a pipe or duct which connects the furnace to a vent or chimney. Vent connectors usually run directly from the furnace's vent collar to the vent or chimney. Vent connectors may have vertical or horizontal runs.

"Venting System" refers to a continuous open passageway from the vent collar to the outside. Venting systems usually have a vent connector(s) and a vent or chimney. Venting systems commonly serve a single furnace or a single furnace and a water heater. Other multiple-appliance venting systems are less common.

"Fan-Assisted Combustion System" refers to an appliance equipped with an integral mechanical means to either draw or force products of combustion through the combustion chamber and/or heat exchanger. This furnace uses a draft inducer to draw combustion products through the heat exchanger and is considered to have a fan-assisted combustion system. Category I furnace with fan-assisted combustion systems must not be vented into single wall metal vents.

GENERAL DESIGN CONSIDERATIONS

These instructions are for venting this furnace as a Category I appliance. Venting system components discussed in these instructions are not appropriate for Category III or VI appliances which have positive pressure venting systems.

WARNING

Do not connect this furnace to a vent system used by other Category III or VI appliances. Do not connect it to vents with mechanical draft systems operation at positive pressure. Improper venting could allow combustion products to collect in building during use, resulting in fire, nausea or asphyxiation.

You must connect furnace to a listed chimney or vent complying with a recognized standard or suitably sized, constructed and lined masonry chimney. Chimney lining method and material must comply with local requirements. Use corrosion-resistant material meeting nationally recognized standards for vent construction.

This furnace must not vent into an unlined masonry chimney or an unlined concrete chimney and must not single appliance vent into a tile-lined chimney. However, this furnace may be common vented into a tile-lined masonry chimney provided (1) the chimney is currently serving at least one drafthood equipped appliance and (2) the vent connectors and chimney are sized in accordance with the appropriate vent table.

WARNING

Select appropriate venting materials and clearances. Inadequate vent or chimney could allow combustion products to collect in building, resulting in fire, nausea or asphyxiation.

WARNING

Do not use unlined masonry chimneys. These increase risk of condensate formation, which may cause chimney to deteriorate, allowing combustion products and condensate to collect in building.

Multistory and common venting with other Category I appliances is permitted. The venting system must be in accordance with the National Fuel Gas Code ANSI Z223.1/NFPA 54, local codes and approved engineering practices.

Vent this furnace separately from any appliance designed to burn solid fuel such as wood or coal. If a fireplace chimney flue is used to vent this appliance, the fireplace opening must be permanently sealed.

Avoid over-sizing furnace for your application. Select a furnace model with a rated heating output close to the calculated heating load. This extends the firing period, decreasing the potential for condensate formation in the vent.

The designer must consider the building's orientation, answering two questions: Will the vent terminate outside the building where its operation could be adversely affected by winds? Could any adjacent building adversely affect vent operation? Allowing for these factors can reduce the possibility of down draft conditions.

If your local experience indicates possible condensation problems, provide for draining and disposal of venting system condensate.

VENT SIZING AND INSTALLATION

Proper vent size can be determined from the instructions, the National Fuel Gas Code ANSI Z223.1/NFPA.

An undersized vent cannot adequately carry all combustion products outdoors. An oversized vent will not heat up rapidly enough to avoid condensation.

Vents and chimneys usually extend vertically with offsets not exceeding 45 degrees from vertical. Consider vent pipe runs more than 45 degrees from vertical as horizontal runs. Include their length in the total horizontal run.

Vent height must be a minimum of five feet for Category I vent systems. Minimize vent connector horizontal runs to the extent possible for best performance. Horizontal portions of the venting system must be supported at each joint using hinges, straps or equivalent to prevent sagging. Slope horizontal portions upward from furnace at least 1/4 inch per foot.

Sometimes the horizontal distance from the furnace to the vent of chimney is already given. This is known as the horizontal vent connector run. The vent or chimney height is also usually given as the Btu per hour input of the gas appliances served by the vent. Check these parameters to be sure the venting system will work. Use these instructions, Part 7 of current National Fuel Gas Code ANSI Z223.1/NFPA 54.

Install vent materials following their listing terms, manufacturer's instructions, these instructions and local codes.

A gas vent passing through a roof must extend through roof flashing, jack or thimble. It must terminate above roof surface.

Designer and installer must provide an appropriately sized common vent for all appliances connected to it. See current National Fuel Gas Code ANSI Z223.1/NFPA 54.

VENT CONNECTORS

Vent connectors must be made of listed single-wall or Type B-1 double-wall components. They must be thick enough to withstand physical damage and be readily accessible for inspection, cleaning and replacement. The clearance for B-1 vent components is one (1) inch minimum to any combustible materials.

Use Type B-1 vent connectors in or through attics, crawl spaces, or other cold areas. Install thimbles that meet local codes when vent connectors pass through walls or partitions of combustible material.

Keep vent connectors as short as possible by locating furnace as close as practical to vent of chimney. Avoid unnecessary turns or bends which create resistance to flow of vent gases. Adding an elbow adds resistance.

You may increase vent connector diameter to overcome installation limitations and obtain connector capacity equal to furnace input. Make this increase as close as possible to furnace vent collar, allowing for necessary adaptors and fittings. Do not increase vent size more than two sizes larger than vent collar. Minimum vent connector diameter from furnace to vent or chimney is same as vent collar. Minimum vent connector diameter from furnace to vent or chimney is same as vent collar.

If you join two or more vent connectors before they enter the vertical vent or chimney, use caution.

Do not connect vent connector to a chimney flue serving a fireplace unless you permanently seal fireplace flue opening.

Attach vent connector to furnace vent collar. Use minimum of three equally spaced sheet metal screws around connection. Connect all other vent pipes using three equally spaced screws at each joint. The only exceptions when you use Type B-1 vent pipe with self locking connections.

WARNING

Unsecured vent pipe connections may loosen. This can allow combustion products to collect in building which could result in injury or death.

LINED CHIMNEYS

Furnace is suitable for venting into a properly sized and lined masonry chimney. Consult National Fuel Gas Code ANSI Z223.1/NFPA 54 for construction details. Consider using chimney as a pathway for suitably sized Type B-1 vent liner. Seal all connections where vent connectors enter chimney. See Figure 8 on Page 14.

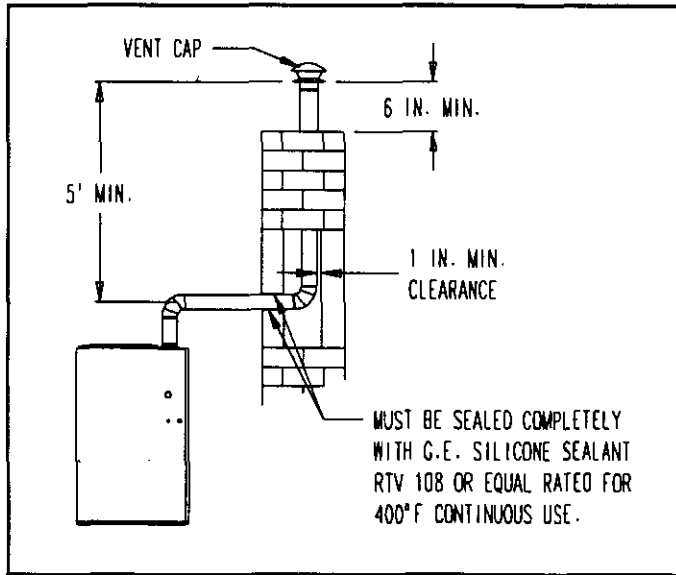

FIGURE 8 – TYPE B VENT LINER

⚠ WARNING

Provide support when using a Type B-1 vent liner in masonry chimney. Maintain at least a 1 inch clearance on all sides to reduce possibility of condensate in vent. Condensate may cause vent to deteriorate allowing combustion products to collect in building, which could result in injury or death. See Figure 9.

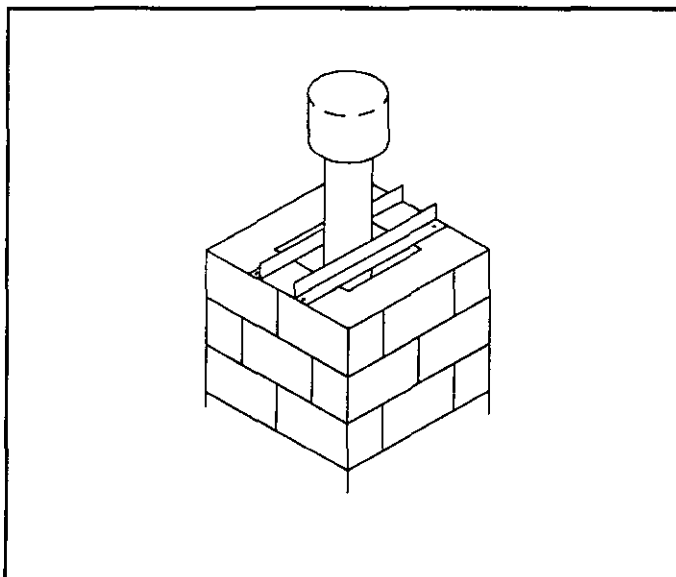

FIGURE 9 – SUPPORTING TYPE B VENT LINER

VENT TERMINATION

Terminate all vertical vents with a listed vent cap or roof assembly unless local codes require otherwise. See vent cap or roof assembly manufacturer's instructions. Locate vent termination (vent cap or roof assembly) in an area without positive wind pressures or eddy currents. Eddy currents occur when air swirls over roof peaks. They can cause down-drafts and adversely affect vent operation. See Figure 10.

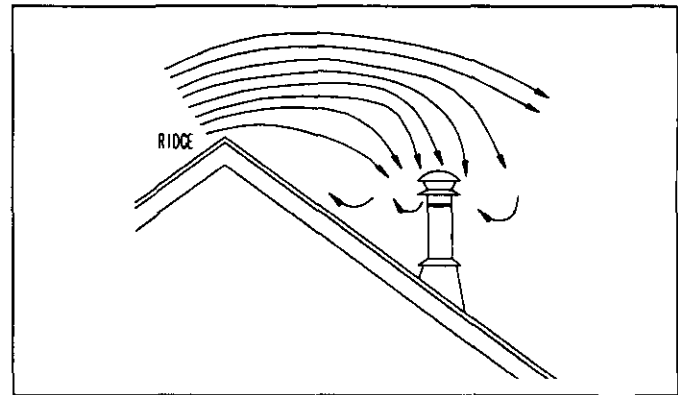

FIGURE 10 – EDDY CURRENTS AROUND TERMINATION CAP

Some vent terminations or caps protect against eddy currents and down-drafts. Consult their manufacturer's instructions. Vent terminations or caps should usually be at least the same size as the vent. They may be larger if the installation warrants.

Vent systems must end at least six feet above the highest gas appliance connection. The vent pipe must extend at least the minimum distance shown, to the bottom of the lowest discharge opening in the listed vent cap, as shown in Figure 11.

ROOF PITCH	MINIMUM HEIGHT
FLAT TO 7/12	1.0 FEET*
OVER 7/12 TO 8/12	1.5 FEET
OVER 8/12 TO 9/12	2.0 FEET
OVER 9/12 TO 10/12	2.5 FEET
OVER 10/12 TO 11/12	3.25 FEET
OVER 11/12 TO 12/12	4.0 FEET
OVER 12/12 TO 14/12	5.0 FEET
OVER 14/12 TO 16/12	6.0 FEET
OVER 16/12 TO 18/12	7.0 FEET
OVER 18/12 TO 20/12	7.5 FEET
OVER 20/12 TO 21/12	8.0 FEET
* This requirement covers most installations.	

FIGURE 11 – GAS VENT TERMINATION TABLE

WARNING

Failure to properly terminate vent or chimney systems could allow combustion products to collect in building.

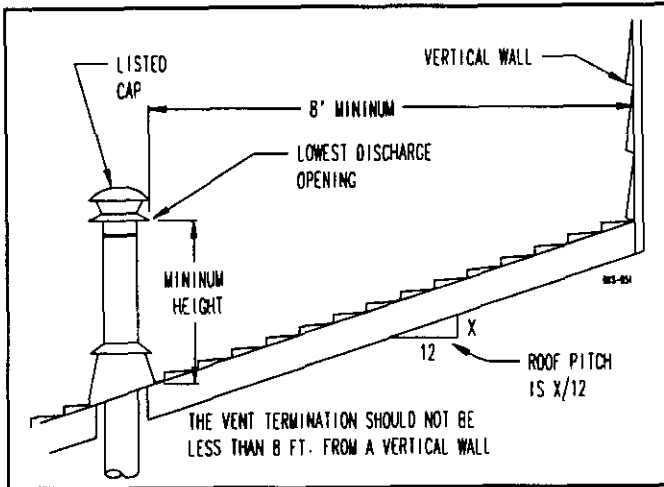

FIGURE 12 – TERMINATION NOT LESS THAN EIGHT FEET FROM A VERTICAL WALL

EXISTING VENT CONSIDERATIONS

Masonry chimneys must be lined with suitable liner. See "Lined Chimneys".

Make sure existing vent or chimney is proper size and construction for appliances that will use it. The best way to do this is to size as if it were a new installation. Compare the existing vent to your calculations and make the necessary corrections.

Examine vent or chimney clean-outs to make sure they remain tightly closed when not in use. Make sure vent chimney passageway is clear and free of obstructions. Look for evidence of condensate or deterioration in vent or chimney. Either of these means an inadequate vent.

If you find an inadequate vent or chimney, do not leave it as is. Repair or replace it. A new vent must meet these instructions and the National Fuel Gas Code ANSI Z223.1/NFPA 54.

WARNING

An inadequate vent or chimney could allow combustion products to collect in building.

When an existing furnace is removed or replaced, the venting system may no longer be properly sized to vent the attached appliances. An improperly sized venting system may promote the formation of condensate, leakage or spillage.

The following steps shall be followed with each appliance connected to the venting system placed in operation, while any

other appliance connected to the venting system are not in operation:

1. Seal any unused openings in the venting system.
2. Inspect the venting system for proper size and horizontal pitch, as required in the National Fuel Gas Code, ANSI Z223.1/NFPA 54 and these instructions. Determine that there is no blockage or restriction, leakage, corrosion and other deficiencies which could cause an unsafe condition;
3. In so far as is practical, close all building doors and windows and all doors between space in which appliance(s) connected to the venting system are located and other spaces of building.
4. Close fireplace dampers.
5. Turn on clothes dryers and any appliance not connected to the venting system. Turn on any exhaust fans, such as range hoods and bathroom exhausts, so they shall operate at maximum speed. Do not operate a summer exhaust fan.
6. Follow the lighting instructions. Place the appliance being inspected in operation. Adjust thermostat so appliance shall operate continuously.
7. Test for drafthood equipped appliance spillage at the drafthood relief opening after 5 minutes of main burner operation. Use the flame of a match or candle.
8. After it has been determined that each appliance connected to the venting system properly vents when tested as outlined above, return doors, windows, exhaust fans, fireplace dampers and any other gas-burning appliance to their previous conditions of use.
9. If improper venting is observed during any of the above tests, the venting system must be corrected. Follow the National Fuel Gas Code, ANSI Z223.1/NFPA 54 and the venting tables provided with the furnace to correct improper vent operation. Any "common vent" resizing must approach minimum size determined using the venting tables.

15. SIDEWALL VENTING

In most cases, proper venting is achieved by using a conventional vertical vent or chimney. However, it is not uncommon to have an installation where venting through a sidewall becomes necessary. This section contains information on venting through a sidewall using a mechanical (power) venter. A mechanical (power) venting system operates at negative pressure to draw the furnace flue products from the structure.

This furnace must not be vented with high temperature plastic pipe.

IN THE UNITED STATES

Any mechanical (power) venting system is acceptable as long as it has been certified by a nationally recognized testing agency and meets all state and local codes. The venter must be installed according to the mechanical (power) venter manufacturer's

installation instructions. It must be sized appropriately for the furnace and be capable of maintaining a negative vent pressure of -0.1 to -0.5 inches W.C. in the vent pipe leaving the furnace under all operating conditions. Because this system operates at negative pressure, any single wall or Type B-1 vent pipe may be used; however, Type B-1 pipe is recommended.

In addition to the venter manufacturer's instructions, the furnace manufacturer requires use of a secondary safety switch which will act to turn off the furnace in the event that the vent pressure becomes positive. These devices are available through the mechanical (power) venter manufacturer.

16. THERMOSTAT

Install the thermostat in accordance with instructions packed with it. Locate the thermostat 4-1/3 feet from the floor on an inside wall away from drafts, warm air registers, and floor or table lamps. Refer to furnace wiring diagrams for connections.

All 24 volt wall thermostats have heat anticipators to compensate the thermostat for various system controls and allow the best possible cycle rates. Some anticipators are fixed and require no adjustment. However, the majority of wall thermostats have adjustable anticipators and do require adjustment to match the current rating of the gas valve. The nominal heat anticipator setting for these furnaces is .45A.

ISOLATING RELAY FOR ELECTRONIC THERMOSTATS

Some designs of electronic thermostats are "power stealing" and operate off of the furnace controls in such a manner as to not be compatible with the Integrated Furnace Control.

Addition of an isolation relay as shown in Figure 13 will correct this compatibility problem and sometimes is a desirable solution as an alternative to replacing the thermostat.

FIGURE 13

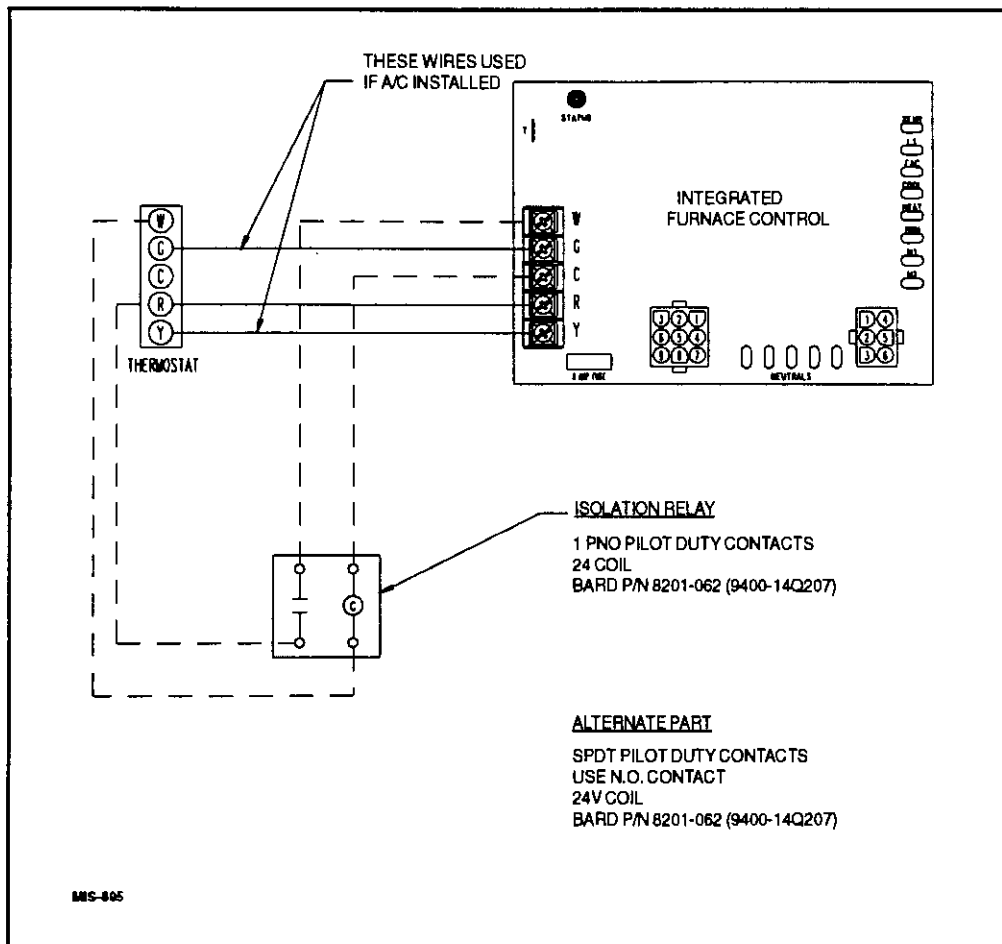

FURNACE TWINNING OPTIONS

Shown below and on pages 18 and 19 are furnace twinning options using three different types of thermostat hookups. Twinning of furnaces (two furnaces tied into a large common duct system installation) is also discussed in Section 22.

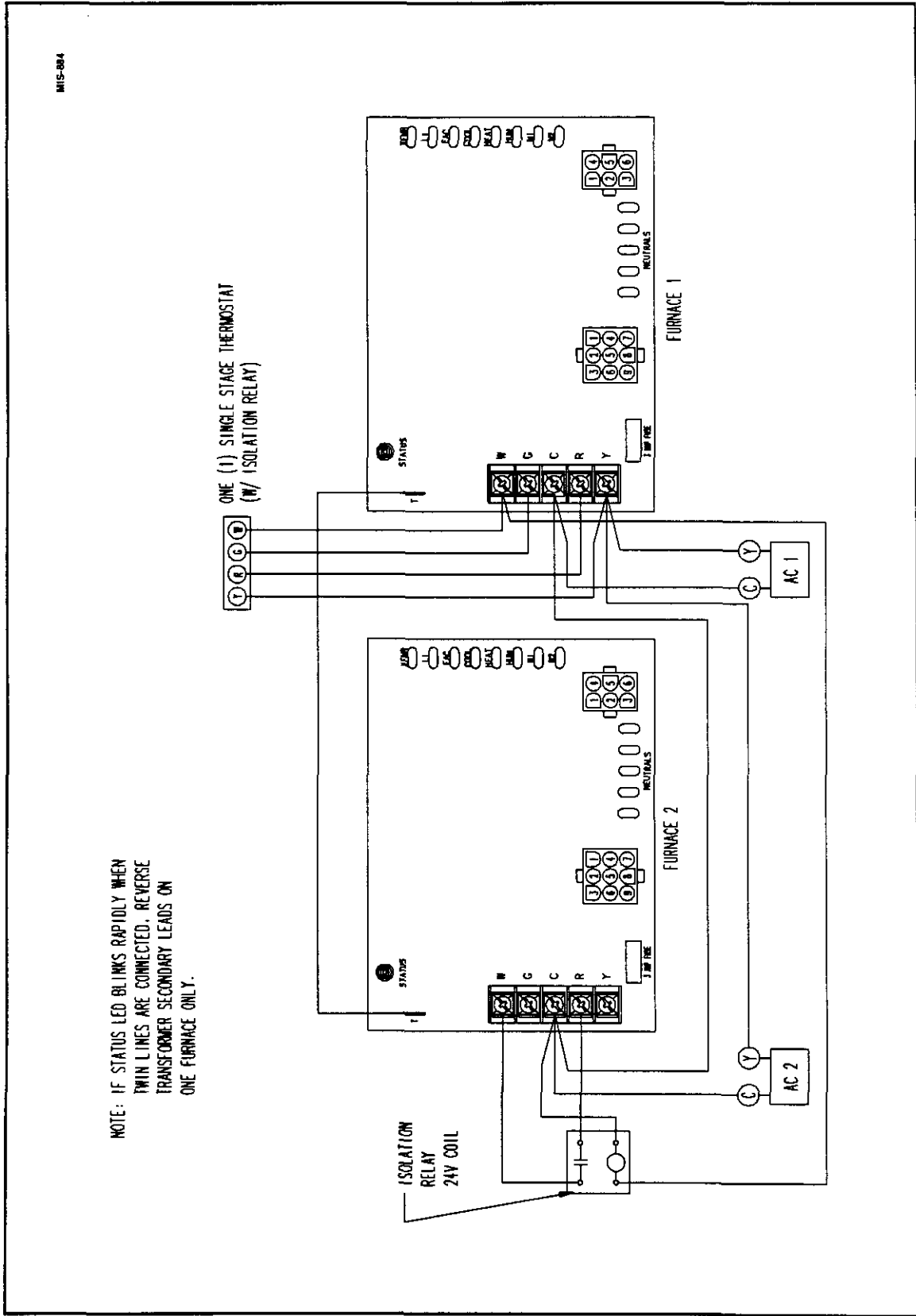

FIGURE 14 – TWINNING DIAGRAM – ONE THERMOSTAT WITH TWO FURNACES AND TWO AIR CONDITIONERS.

NOTE: IF STATUS LED BLINKS RAPIDLY WHEN TWIN LINES ARE CONNECTED, REVERSE TRANSFORMER SECONDARY LEADS ON ONE FURNACE ONLY.

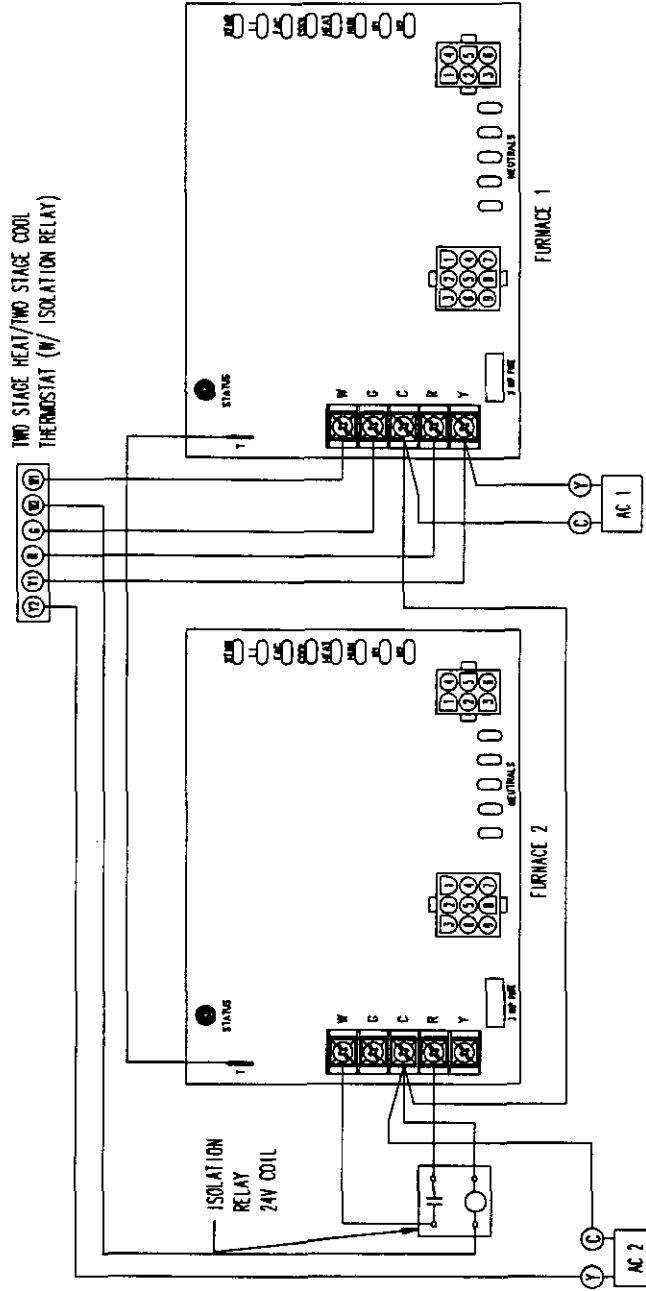

FIGURE 15 - TWINNING DIAGRAM - TWO STAGE HEAT/COOL THERMOSTAT WITH TWO FURNACES AND TWO AIR CONDITIONERS

NOTE: IF STATUS LED BLINKS RAPIDLY WHEN TWIN LINES ARE CONNECTED, REVERSE TRANSFORMER SECONDARY LEADS ON ONE FURNACE ONLY.

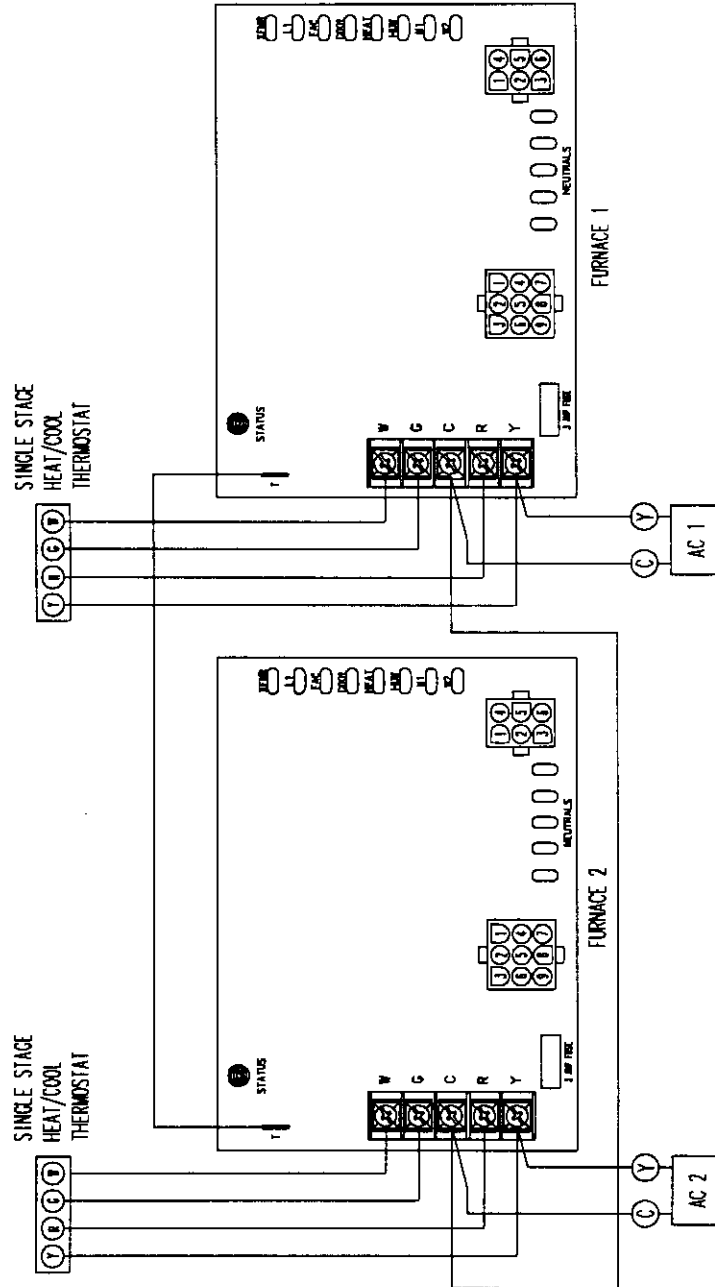

FIGURE 16 - TWINNING DIAGRAM - SEPARATE THERMOSTAT FOR EACH FURNACE AND AIR CONDITIONER

17. ADJUSTING BLOWER SPEED

Determine initial heating and cooling speeds in system design stage. See Product Data Sheet for airflow data. Depending on tests performed in following sections, you may need to change blower motor speed.



CAUTION

Heating speed tap should not be reduced below factory setting. Doing so may result in inadequate air circulation, and could cause excessive air temperature rise through furnace. This could cause high-temperature limit switch to cycle burners on and off, reducing furnace efficiency and shortening life of heat exchanger and blower motor.

Follow this procedure:

1. Turn off electricity at electrical disconnect switch located next to furnace.



WARNING

To prevent electric shock, turn off electrical power to furnace before changing blower motor speed

2. All models have three or four motor speeds:

3 SPEED	4 SPEED	COLOR
Common	Common	White
High	High	Black
Med	Med-High	Blue
	Med-Low	Orange
High	High	Red

3. To change cooling speed, move the desired motor lead to the terminal marked "COOL" on the Control Module. Initial factory setting for cooling is high speed (black wire).
4. To change the heating speed, move the desired motor lead to the terminal marked "HEAT" on the Control Module. Factory setting for heating is listed in Table 9. Heating speed should not be reduced below factory setting.

5. Connect unused motor leads to the terminals marked M1 or M2 on the Control Module.
6. If common heat and cool speed operation is required because of A/C size, connect desired speed to both COOL and HEAT terminals using a jumper wire. On 4 speed motors, the third unused speed lead will require the end securely taped off with electrical tape.



WARNING

Failure to properly terminate unused motor leads could cause electrical shock.

7. Turn on the electricity at electrical disconnect switch located next to furnace.

18. MEASURING DUCT SYSTEM STATIC PRESSURE

System airflow can be determined from the Product Data Sheet when duct system static pressure is known.

Improper airflow in heating mode may result in poor heating performance and reduced heat exchanger life. Improper airflow in cooling mode may cause poor cooling performance or air-conditioning coil freeze-up.

High duct system static pressure is an indication of an overly restrictive duct system. Static pressure in excess of 0.5 inches W.C. indicates a need for duct system redesign to ensure proper volume of air flow.

You will need a 0 to 1 inch W.C. slope gauge with 0.01 inch resolution and two pressure measurement taps.

Follow this procedure:

1. Open supply air registers and return air grilles. Make sure the registers and grilles are free of obstruction from rugs, carpets, drapes or furniture.
2. Set balancing dampers in supply duct system.
3. Check duct work for obstructions or leaks.
4. Make sure filters are clean and in place.
5. Make sure that blower speed taps are set for proper heating and cooling. Refer to Section 17, "Adjusting Blower Speed". Heating speed should be set according to Table 9. Cooling speed should be set to meet cooling equipment requirements. See Table 9 for cooling air flow capacities at 0.5 inch W.C.
6. Place slope gauge near furnace, level and adjust scale to read 0.00 inches W.C.

TABLE 9 – AIRFLOW CAPACITIES AND MOTOR SPEED INFORMATION

Model	Heating Input (Btu/hour)	Motor Size (HP)	Blower Size	Temp Rise (F)	Motor FLA (Amps)	Motor Speed Tap	Cooling @ 0.5 in WC (Tons)	AIRFLOW* vs. STATIC PRESSURE					
								(CFM)			(Inches WC)		
								0.1	0.2	0.3	0.4	0.5	0.6
TU044	44,000	1/3	10 x 6	30 - 60	4.5	HI	2.5	1255	1225	1180	1135	1105	1075
						MED	2.0	850	825	815	805	785	750
						LO	1.5	655	645	635	620	610	575
TU066	66,000	1/3	10 x 8	30 - 60	6.5	HI	3.0	1480	1435	1385	1350	1325	1300
						MED	2.5	1165	1140	1110	1090	1060	1015
						LO	2.0	890	870	865	840	805	750
TU088	88,000	1/3	10 x 10	45 - 75	10.5	HI	4.0	2110	2045	1955	1890	1810	1700
						MED-HI	3.5	1780	1745	1725	1675	1615	1550
						MED-LO	3.0	1400	1390	1385	1375	1360	1315
						LO	2.5	1035	1050	1075	1115	1100	1075
TU110	110,000	3/4	11 x 10	45 - 75	12.5	HI	5.0	2325	2285	2230	2145	2060	1970
						MED-HI	4.0	1870	1830	1805	1765	1730	1690
						MED-LO	3.5	1525	1520	1500	1470	1445	1420
						LO	3.0	1355	1345	1315	1285	1270	1225
TU132	132,000	3/4	11 x 10	45 - 75	12.5	HI**	5.0	2455	2410	2360	2315	2255	2190
						HI	5.0	2310	2190	2095	1960	1830	1665
						MED-HI	4.0	1785	1755	1710	1675	1640	1610
						MED-LO	3.5	1510	1490	1460	1435	1420	1395
						LO	3.0	1305	1295	1290	1275	1260	1225

* All airflow data shown is without filter and with on side return air opening used except as noted by **. Either side opening or the bottom opening can be used individually or in combination with one another. No filters are supplied with the furnace. Filter velocities should not exceed 400 FPM for Fiberglass (disposable) type, and 575 FPM for washable type filters. Filters should be spaced a minimum of 1 inch from the furnace side to permit full utilization of the filtering media. Bard optional filter racks FR23 (16x25x1 with 1 in. space to furnace side) and FR24 (20x25x1 with 2 in. space to furnace side) are available and supplied with durable expanded aluminum mesh washable filters.

** Airflow ratings using both side returns or the bottom return opening.

 Shaded speed is factory wired heating speed.

7. Insert one static pressure tap into supply air transition duct between furnace and cooling coil or in the supply air plenum for heating only systems. Connect this pressure tap to positive pressure side of slope gauge. See Figure 17.
8. Insert other static pressure tap in return air plenum. Connect this pressure tap to negative pressure side of gauge. See Figure 17.

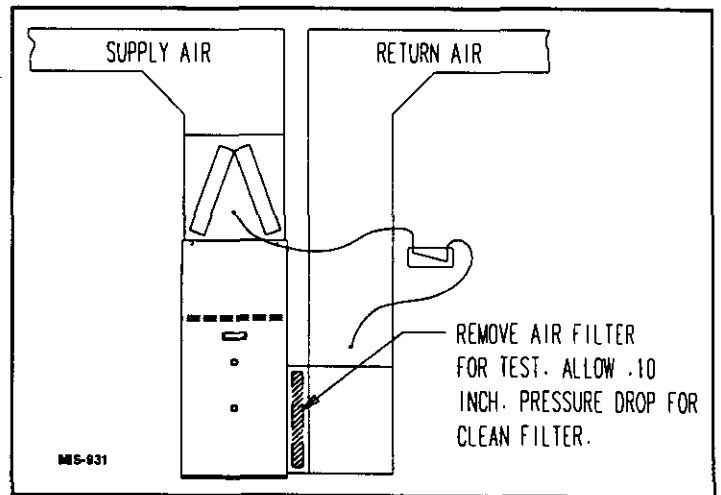

FIGURE 17 – MEASURING DUCT SYSTEM STATIC PRESSURE

19. MEASURING AIR TEMPERATURE RISE

Air temperature rise (supply air temperature minus return air temperature) must be within allowable air temperature rise range specified on furnace rating plate and in Table 9.

You will need 2 thermometers with 1 degree resolution capable of reading up to 200 degrees F. Check thermometers to make sure they agree, or compensate accordingly.

Follow this procedure:

1. Open supply air registers and return air grilles. Make sure the registers and grilles are free of obstruction from rugs, carpets, drapes or furniture.
2. Set balancing dampers in supply duct system.
3. Check duct work for obstructions or leaks.
4. Make sure filters are clean and in place.
5. Make sure that blower speed taps are set for proper heating and cooling. Refer to Section 17, "Adjusting Blower Speed". Heating speed should be set according to Table 9. Cooling speed should be set to meet cooling equipment requirements. See Table 9 for cooling air flow capacities at 0.5 inch W.C.
6. Place one thermometer in supply air plenum approximately 2 feet from furnace. Locate thermometer tip in center of plenum to ensure proper temperature measurement.
7. Place second thermometer in return air duct approximately 2 feet from furnace. Locate thermometer tip in center of duct to ensure proper temperature measurement.
8. Set room thermostat on highest temperature setting. Operate furnace 10 minutes. Record supply air and return air temperatures.
9. Calculate air temperature rise by subtracting return air temperature from supply air temperature.
 - If air temperature rise is above the temperature rise range specified on Table 9, furnace is overfired or has insufficient airflow. Check gas input following the instructions in Section 10, "Checking Gas Input Rate". If air temperature rise is still above temperature rise range specified, more heating air flow is needed. Change blower heating speed to a higher setting following instructions in Section 17, "Adjusting Blower Speed".
 - If air temperature rise is below the temperature rise range specified in Table 9, furnace is underfired or has too much airflow. Check gas input following the instructions in Section 10, "Checking Gas Input Rate". If air temperature rise is still below temperature rise range specified, less heating air flow is needed. Change blower heating speed to a lower setting following instructions in Section 17, "Adjusting Blower Speed".
 - After making adjustments, you must check air temperature rise to verify that resulting air temperature rise is within allowable range. If air temperature rise is still outside the temperature rise range specified in Table 9, check duct system design with a qualified heating engineer. It may be necessary to re-size the duct work. Recheck air temperature rise after revising duct systems.

10. Set room thermostat to desired setting.

11. Remove thermometers and seal duct work holes.

NOTE: Failure to seal holes could result in reduced system performance.

20. FILTERS

Filters are not shipped with furnace. Filter rack and filters are available through your dealer. Filter sizes of a washable type must be used per the chart below to maintain acceptable air velocity.

Model	Size	Quantity	Filter Rack
TU044	16 x 25 x 1	1	FR23
TU066	16 x 25 x 1	1	FR23
TU088	16 x 25 x 1	1	FR23
TU110	16 x 25 x 1	2 ‡	FR23
	20 x 25 x 1	1	FR24
TU132	16 x 25 x 1	2 ‡	FR23
	20 x 25 x 1	1	FR24

‡ For 5 Ton cooling applications, two 16x25x1 filters (one per return drop) are required to maintain proper flow velocities. If one return drop is used, a 20x25x1 filter and the appropriate 20x25 filter rack must be used. These items are available through your dealer.

See Figure 18 for typical installation of a 16x25x1 filter rack (Part No. FR23) centered over the 14x23 cutout. The 2 inch depth of the filter rack provides ample spacing between furnace side and leaving edge of filter for the entire filter surface to be effective.

Figure 19 shows a typical installation of a 20x25x1 filter rack (Part No. FR24). The same 14x23 cutout is required in the furnace side, and the bottom of the filter rack is aligned over the bottom of the 14x23 cutout. The top of the filter rack rises approximately 6 inches above the top of the cutout. The 3 inch depth of the filter rack provides ample spacing between furnace side and leaving edge of filter for the entire filter surface to be effective.

To remove filter from the filter rack (see Figures 18 and 19), remove the filter access cover and grasp the end of the filter.

This filter is the washable high velocity type filter which may be washed and used over and over. **DO NOT** replace it with a fiberglass disposable filter of the same size.

To replace filter, reverse the above procedure.

FIGURE 18 – TYPICAL INSTALLATION OF A FR23 FILTER RACK

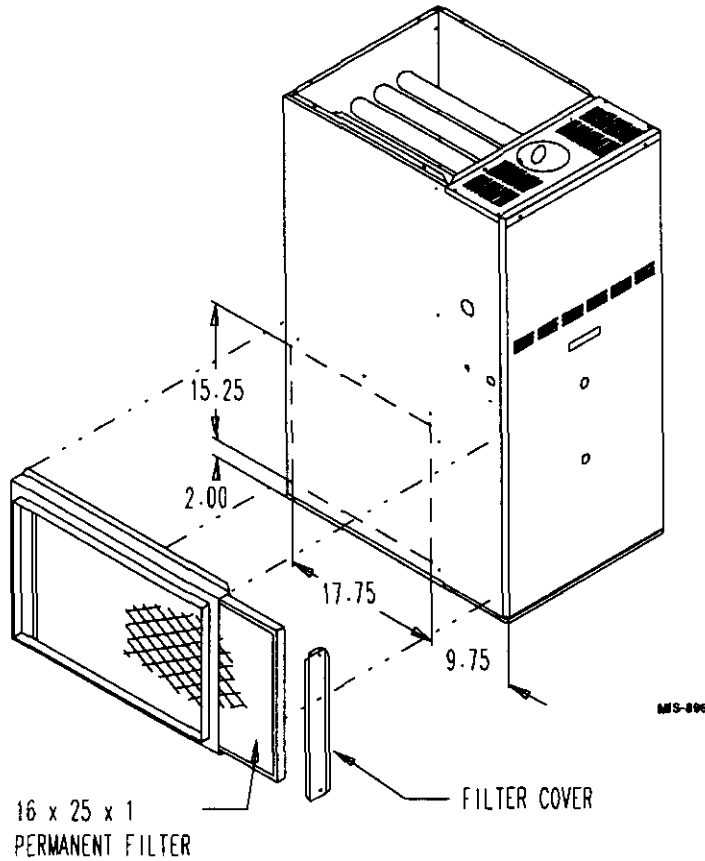
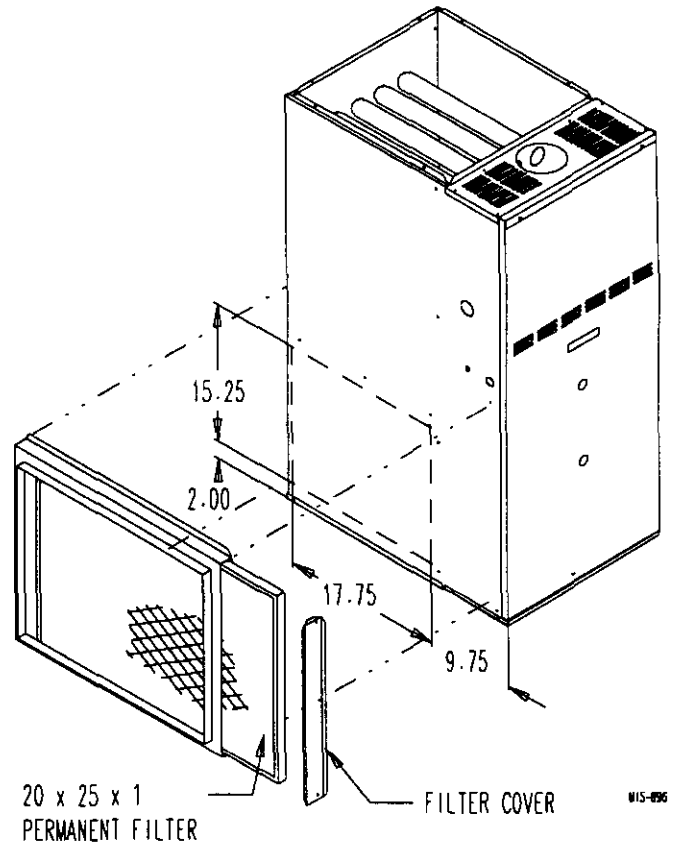

FIGURE 19 – TYPICAL INSTALLATION OF FR24 FILTER RACK



21. SEQUENCE OF OPERATION

The operation sequence shown below describes normal operation. See Section 22 for detailed explanation of Integrated Furnace Control (IFC), and explanations of normal occurrences.

1. BASIC FURNACE – HEATING CYCLE

This furnace is operated by an Integrated Furnace Control (IFC) which controls all functions of the furnace.

On a call for heat from the thermostat, the IFC first checks the pressure switch to verify contacts are open then turns on the inducer motor. The pressure switch then closes signaling the IFC to proceed with ignition function.

There is a 36 second ignitor heat-up period then the gas valve opens introducing main burner gas to be ignited by the hot surface ignitor. The ignitor turns off 6 seconds after gas valve opens, and the flame sensor must prove ignition and carryover across all burners with 9 seconds after the gas valve opens.

There is a 30 second delay after main burner is on until the comfort air blower starts on heating speed. After the thermostat is satisfied, the burners will go off as gas valve closes. The inducer will continue to run for 30 seconds, and the comfort air blower will continue to run for 120 seconds standard. This can be changed to 60, 90, or 150 seconds. See Wiring Diagram on Page 30.

** IMPORTANT **

The furnace cannot be recycled from the wall thermostat during the heating blower off delay period. A new call for heat can be initiated during this period but the system will "wait" until the blower off delay times out.

2. ACCESSORIES (OPTIONAL, FIELD INSTALLED)

The furnace and IFC are designed to accommodate both electronic air cleaner and humidifier. The electronic air cleaner circuit is powered any time the comfort air blower runs on either heating or cooling speed. The humidifier circuit is powered anytime the inducer motor is operating. See Section 16 for more information.

3. COOLING CYCLE OPERATION

If optional add-on air conditioning system is installed, the comfort air blower starts on cooling speed 6 seconds after call for cool; will run continuously during the call for cool; and will stop 60 seconds after the thermostat is satisfied.

4. **MANUAL FAN (CONTINUOUS AIRFLOW) OPERATION**

If wall thermostat is set to MANUAL (ON) position to operate comfort air blower continuously to provide air circulation throughout the building, the blower will operate on the heating speed rather than the cooling as is typical with most systems. This permits the air to circulate as desired but helps keep the operating noise level down as well as conserving energy.

When a call for heat occurs, the blower will continue to run during the ignitor heat up period.

During a call for cooling, the blower automatically shifts up to cooling speed, and remains there until 60 seconds after thermostat is satisfied than drops back to heating speed.

22. **INTEGRATED FURNACE CONTROL (IFC)**

The Integrated Furnace Control (IFC) controls all aspects of the furnace operation. Shown below are the IFC specifications covering Ignition Sequence Control, Comfort Fan Control, Accessory Control, and Diagnostics.

Specific information on TWINNING of furnaces (2 furnaces tied into a large common duct system installation) is detailed under "Thermostats" – Section 16. This twinning feature assures simultaneous starting and stopping of the comfort air blowers in each furnace which is essential to prevent air short circuiting through one of the furnaces if the blower is only running in the other furnace.

DIAGNOSTICS are provided through a light emitting diode (LED) mounted on the IFC. A clear sight glass is located in the vestibule door lining up with the LED. Therefore, the LED can be observed without removing any furnace panel to determine operating status or problem condition that might be present.

TABLE 10 –

IGNITION SEQUENCE CONTROL	
Ignition Source	115 VAC HSI (Norton 201)
Flame Sensing	Remote
Timings	
- prepurge	0 seconds
- postpurge	0 seconds (0 if cycle terminated before valve "on")
- inter-trial purge	30 seconds
- pressure switch proving period	60 seconds
- trials for ignition	3 per ignition sequence
- 1st trial heat up	36 seconds
- 2nd and 3rd trials (if needed)	46 seconds
- trial for ignition	9 seconds total time to prove flame - valve + ignitor on for 1st 6 seconds - valve only for last 3 seconds
- ignition sequence lockout	60 minutes (after 3 trials for ignition), auto reset - can be reset during the 60 minute lockout period by opening thermostat circuit for 3 seconds or more
- heat blower on-delay	30 seconds (timing starts when ignitor cycles off)
- heat blower off-delay	60 - 90 - 120 - 150 seconds selectable, factory set at 120
- cool blower on-delay	6 seconds
- cool blower off-delay	60 seconds
- manual fan operations	Operates on selected heating speed and does not cycle off during ignition or burner start-up sequence
- high limit control operation	Automatic reset, ignition sequence restart is delayed for 5 minutes after the limit resets. See Note 1.
- flame rollout switch operation	Manual reset, ignition sequence is delayed for 5 minutes after switch is manually reset. See Note 1.
<p>Note 1: After either high limit switch or flame rollout switch actuation the inducer will operate for the 30 second post purge and the comfort air blower will operate for the selected off delay. If on Manual Fan operation, the comfort air blower will continue to operate.</p>	
SAFETY INPUTS	
High Limit/Rollout	SPST in 24 volt circuit
Pressure Switch	SPST, safe start check (60 seconds proving time)

COMFORT FAN CONTROL

Heating Speed Fan

Normal Operation
– on delay

30 seconds fixed. Timing starts when ignitor de-energized. 4 selectable timings – 120 seconds standard, can be changed to 60, 90 or 150 seconds.

Limit Operation

ON when limit OPEN

OFF after OFF delay when limit CLOSES

Flame Sense

ON if flame is sensed and there is no call for heat

Cooling Speed Fan

– ON Delay
– OFF Delay

6 seconds

60 seconds

Manual Fan

ON continuously on HEATING speed. When call for cool, the fan switches to COOLING speed. Then when thermostat satisfied, the fan switches back to HEATING speed after COOLING OFF delay.

ACCESSORY CONTROL

Electronic Air Cleaner

ON/OFF with comfort fan

Humidifier

ON/OFF with combustion blower*

* Atomizing type humidifier requires use of sail switch.

FAULT CODES – LED SIGNAL

- heartbeat
- rapid flash
- steady ON
- 1 short flash
- 2 short flashes
- 3 short flashes

- 1 long, 3 short flashes

- 4 short flashes
- 5 short flashes
- OFF (out)

Standby condition (waiting for thermostat command)

Either a wrong line voltage polarity condition or twinning fault

Call for heat initiated and normal operation

Ignition sequence fault

Pressure switch normally open contacts are stuck closed

Pressure switch did not close during the 60 second proving period (Inducer, pressure switch, tubing or vent problem)

Pressure switch opened during the run cycle and did not re-close during 30 second inducer postpurge period

Safety circuit open (high limit switch or flame rollout switches)

False flame or valve energized without a call for heat

No 115V or 24V power, or Integrated Control failure. Also check 3A fuse on IFC.

23. FIELD INSTALLED ELECTRONIC AIR CLEANER AND HUMIDIFIER

An electronic air cleaner (EAC) and/or humidifier can be connected to the IFC for ease of installation. A 115V power supply output is to the two terminals on the IFC marked "HUM" and "EAC". See Wiring Diagram on Page 28.

115V Electronic Air Cleaner (EAC) – Powered whenever the comfort air blower is operating.

115V Humidifier (HUM) – Powered whenever the combustion air blower is operating.

Humidifier Notes:

1. Atomizing type humidifiers also require a sail switch to be installed in the comfort air duct system to permit humidifier operation only when comfort air fan is on. The sail switch is wired in series with the wire going to the HUM terminal on the IFC.

2. A 24V humidifier motor or solenoid will require a 115 x 24V transformer. If not included with humidifier, it will need to be supplied separately.

24. SERVICING THE FURNACE

The following procedures must be performed by a qualified dealer serviceman.



WARNING

Label all wires prior to disconnection when servicing controls. Wiring errors can cause improper and dangerous operation. Verify proper operation after servicing.

WARNING

Follow these procedures before inspecting the furnace:

- Turn room thermostat to its lowest or off position.
- Turn off manual gas shut-off valve
- Wait at least 5 minutes for furnace to cool if it was recently operating.
- Turn off furnace electrical power. Failure to do so could result in injury or death.

WARNING

Use replacement parts listed in parts list. Failure to do so could cause improper furnace operation resulting in injury or death.

CHECKING THE CIRCULATING AIR BLOWER ASSEMBLY

1. Disconnect main power to unit.
2. Unplug 3 connectors as shown. (See Figure 20)
3. Reposition wire harness setup away from front of blower door.
4. Loosen 2 blower door screws. Door will hinge back towards the front of unit.
5. While blower door is still hooked into bottom of unit, reach in and unplug comfort air blower connector from back of blower door.
6. Remove blower door.
7. Remove two screws securing blower assembly. (See Figure 21)
8. Slide blower out of unit to perform inspection and service.
9. Reassemble unit by reversing steps above.

FIGURE 20

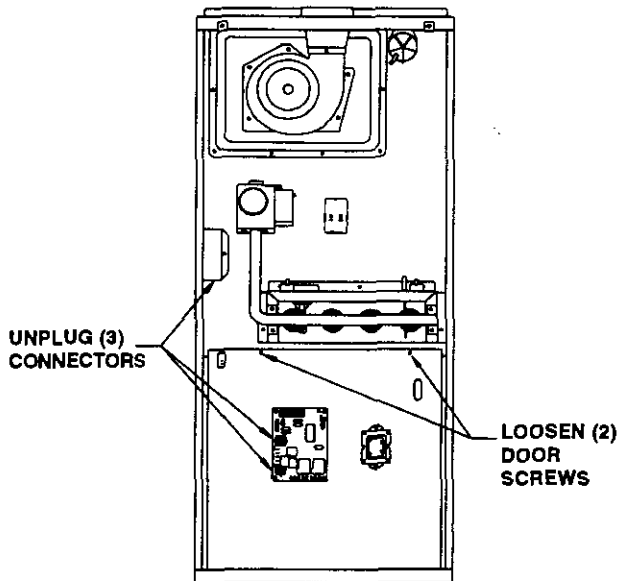
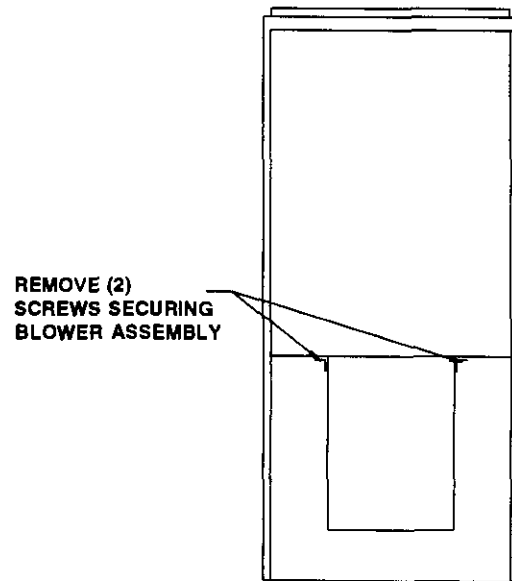

FIGURE 21



M5-809

CHECKING THE HOT SURFACE IGNITOR

1. Unplug ignitor plug from wire harness.
2. Using an ohmmeter, check the resistance of the ignitor. Cold resistance should be 45 - 250 ohm. Resistance above 250 ohms could indicate a fracture or hairline crack and ignitor should be replaced.
3. To replace ignitor carefully remove the two screws securing the ignitor to the top of the burner box. Carefully pull straight up on the ignitor until the element has cleared the top of the box.
4. Replace the ignitor by reversing the above steps.
NOTE: Be sure to install ignitor straight into the hole in the burner box and not on an angle as the ignitor element may break.

CHECKING FLAME SENSOR

1. Flame sensor current should be a minimum of 0.20 micro amps to hold in flame detection circuit.
2. If burner drops out at end of 9 second flame proving period, the flame sensor should be checked and replaced if necessary. Possible problems are sensor rod being coated with airborne foreign substance such as silicone.

CHECKING THE BURNERS

1. Inspect the burner assembly for any scaling, sooting or blockage of ports. If there are signs of this, the burner should be removed and cleaned.
2. The gas piping to gas valve will usually require disconnection to permit valve and manifold assembly to be unfastened and moved out of the way to allow burner assembly to be extracted from furnace.
3. Remove 2 screws under both left and right side of burner box, and lower burner/bracket assembly from box.
4. The burner is now free to be pulled out and examined and cleaned as outlined in Step 1 above.
5. Reinstall all parts by reversing above steps.

CHECKING THE HEAT EXCHANGER AND FLUE GAS PASSAGEWAYS

Furnaces that are properly installed and maintained will normally not require cleaning of the heat exchangers.

THE ONLY TIME it should be necessary to disassemble and clean the interior of the primary heat exchanger would be due to a sooting condition caused by abnormal combustion.

The inside of the primary heat exchanger can be examined for scale and soot using a flashlight. If soot and/or scale is evident, the heat exchanger must be cleaned as follows:

1. Remove burner assembly from inlet to heat exchanger.
2. Disconnect the 2 pin connectors for inducer motor, unplug pressure switch tubing from inducer, and carefully remove the 5 screws securing inducer housing to the flue collector box.

3. Carefully remove the inducer housing from the flue collector box.
4. Remove the flue collector box.
5. Insert vacuum cleaner suction hose into one end of heat exchanger tube. Use flexible handle brush or rag attached to end of electrical fish tape, and work into the other end of heat exchanger tube that the vacuum is attached to. Depending on type of cleaning apparatus available it may not be possible to push entirely through the heat exchange tube. If this is the case, reverse ends with the suction hose and brush/rag and clean from the other end. Repeat for all heat exchanger tubes.
6. Reinstall all parts by reversing above steps.

25. MAINTENANCE INSTRUCTIONS

 WARNING
Use replacement parts listed in parts list only. Use of incorrect parts on this furnace could cause improper furnace operation, resulting in damage, injury or death.

Inspection and cleaning by a qualified service person should be performed once before each heating season begins and once during heating season. Make sure the inspection includes each of the items listed below.

Before inspecting furnace:

1. Turn room thermostat to its lowest or off setting.
2. Turn off equipment shut-off valve.
3. Wait at least five minutes for furnace to cool if it was recently operating.
4. Turnoff furnace electrical power.

 WARNING
Failure to disconnect electrical power before servicing could result in electrical shock or death.

Inspect the following:

1. Check the condition of air filters on at least a monthly basis when the furnace is in use. Clean or replace whenever it is necessary.
2. Adjust blower speed if necessary to obtain a temperature rise within the range specified on the furnace rating plate.

3. An operation check of the entire system. Assure that the furnace is operating properly and safely.
4. Vent connector and vent pipe must be in place, slope upward at least 1/4 inch per foot and must be physically sound, without holes or excessive corrosion.
5. All venting components including vent connector, vent pipe, chimney and vent cap must be clear and free of obstructions.
6. Furnace-room or closet combustion and ventilation air openings must be clear and free.
7. Furnace combustion air openings must be clear and free.
8. Return air duct must be physically sound, sealed to the furnace casing and ending outside the space containing the furnace.
9. Supply air ducts and return air ducts must be clear and free, and without air leaks.
10. Registers and return grilles must be open and unobstructed by rug, carpet or furniture.
11. The furnace must be well supported without sagging, cracks, gaps, etc. around the base.
12. There must be no obvious signs of deterioration of the furnace. Inspection must include burners, pilot, heat exchanger, inducer pan and draft inducer.
13. Inspect all electrical wiring and connections, including electrical ground.

14. Gas pipes must be checked for leaks using a commercial soap solution made to detect leaks.
15. Main burners and pilot burner must be in good adjustment as shown in the User's Information Manual. Main burner flame must be clear blue and centered within the heat exchanger openings.
16. Check the furnace area for combustible materials, flammable liquid near the furnace, corrosive materials, insulation

26. REPLACEMENT PARTS

Replacement parts for the gas furnaces are available through local distributors.

Parts list covering all of the normally serviceable items are listed in the Replacement Parts Manual supplied with this furnace.

WHEN ORDERING PARTS OR MAKING INQUIRIES PERTAINING TO ANY OF THE FURNACES COVERED BY THESE INSTRUCTIONS, IT IS VERY IMPORTANT TO ALWAYS SUPPLY THE COMPLETE MODEL NUMBER AND SERIAL NUMBER OF THE FURNACE.

This is necessary to assure that the correct parts (or approved alternate parts) are issued to the service agency.

The replacement parts manual number is: **2110-873**

27. ELECTRICAL CIRCUIT – LADDER DIAGRAM

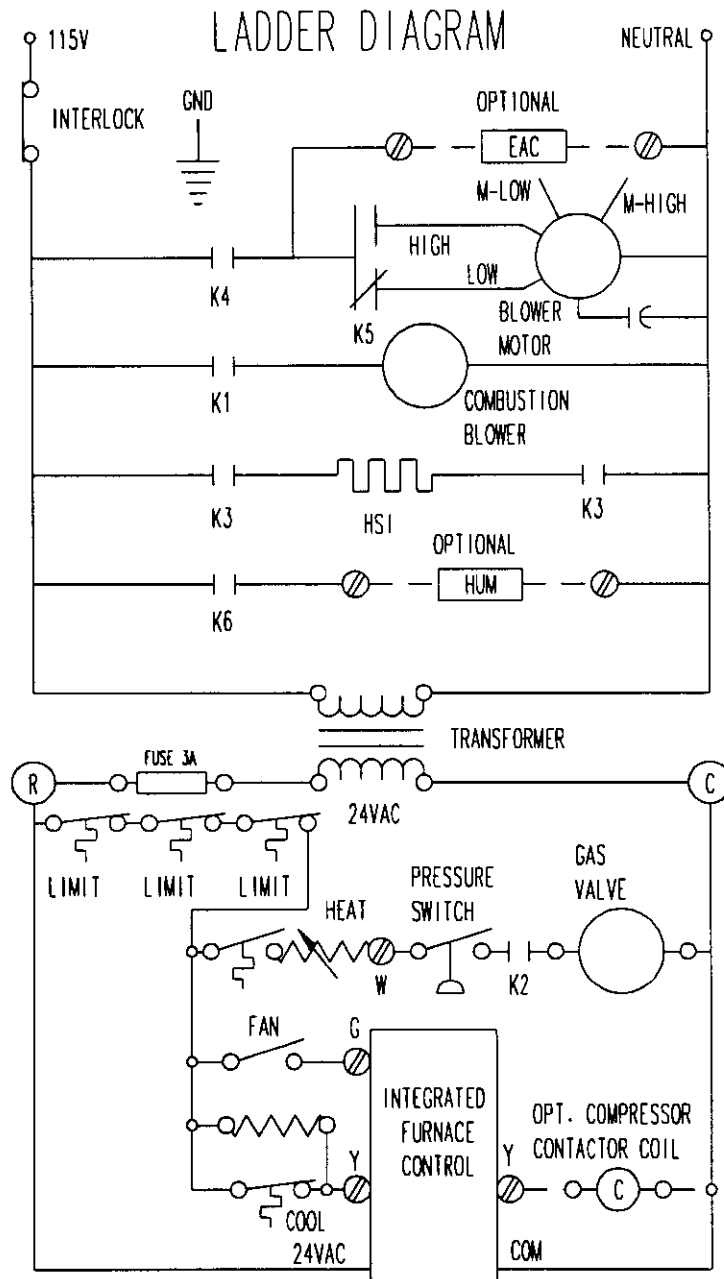

4046-151

28. WIRING DIAGRAM

