

---

# QTEC Series Packaged Heat Pump

## Installation Instructions

Models:  
QH241    QH301  
QH361    QH421  
QH481

---

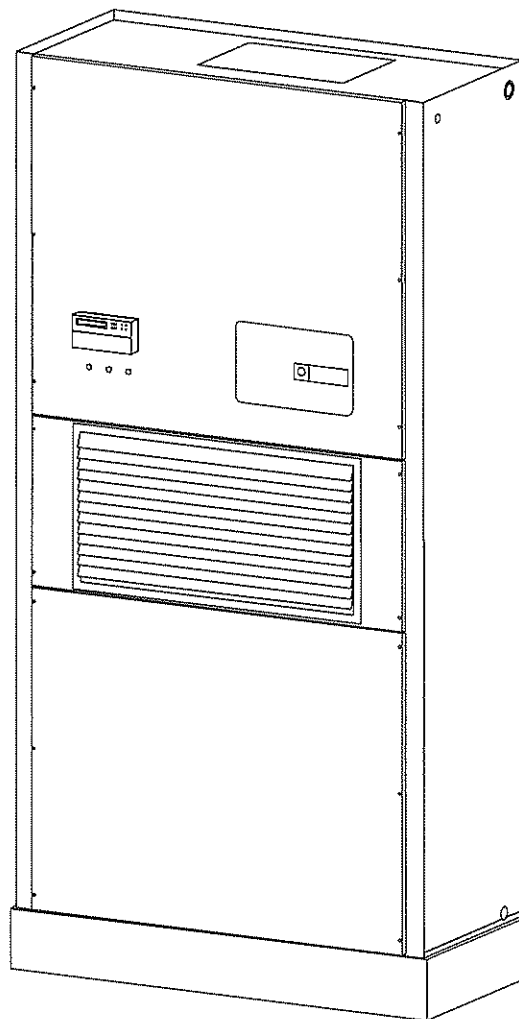

MIS-873



Bard Manufacturing Company  
Bryan, Ohio 43506

*Since 1914...Moving ahead, just as  
planned.*

Manual No.: 2100-288E  
Supersedes: 2100-288D  
File: Vol II Tab 14  
Date: 05-03-99

© Copyright 1999

# Contents

---

<b>Getting Other Information and Publications</b> .....	<b>1</b>
For more information, contact these publishers: .....	1
<b>QTEC General Information</b> .....	<b>2</b>
QTEC Model Nomenclature .....	2
Shipping Damage .....	6
Unit Removal From Skid .....	6
Handling Unit After Removal From Skid .....	7
General .....	7
Minimum Installation Height .....	7
Duct Work .....	9
Filters .....	9
Dirty Filter Switch Adjustment .....	10
Fresh Air Intake .....	10
Condensate Drain .....	10
Service Lights .....	11
<b>Installation Instructions</b> .....	<b>12</b>
Mounting the Unit .....	12
Wiring — Main Power .....	13
Wiring — Low Voltage Wiring .....	13

## Figures

Figure 1	Unit Dimensions .....	5
Figure 2	Air Seal on Bottom of Unit .....	6
Figure 3	Removal of Unit From Skid .....	6
Figure 4	Unit on Appliance Cart for Moving .....	7
Figure 5	Installation With Free Blow Plenum .....	8
Figure 6	Ducted Application .....	8
Figure 7	Supply Duct Connections .....	9
Figure 8	Filter Location .....	9
Figure 9	Side Drain .....	10
Figure 10	Optional Rear Drain .....	10
Figure 11	Rear Drain (Top View) .....	11
Figure 12	Unit Mounting .....	11
Figure 13	Unlocking Wheels of Unit .....	12
Figure 14	Component Location .....	13
Figure 15	Thermostat Plug Terminals P2 .....	14
Figure 16	Remote Thermostat Wiring Diagram .....	14
Figure 17	Wiring Diagram .....	15
Figure 18	Wiring Diagram .....	16
Figure 19	Wiring Diagram .....	17
Figure 20	Fresh Air Damper Removal .....	20
Figure 21	QERV Removal .....	21
Figure 22	Heat Pump Control Board .....	23
Figure 23	Fan Blade Setting .....	24

<b>Start Up</b> .....	<b>18</b>
Description of Standard Equipment .....	18
Optional CFM (QH361, QH421 and QH481 Only) .....	18
Important Installer Note .....	18
Three Phase Scroll Compressor Start Up Information .....	18
Service Hints .....	18
Mist Eliminator Service .....	19
Sequence of Operation .....	22
Optional Climate Controls Sequence of Operation .....	22
Pressure Service Ports .....	22
Defrost Cycle .....	23
<b>Troubleshooting</b> .....	<b>24</b>
Solid State Heat Pump Control Troubleshooting Procedure .....	24
Checking Temperature Sensor .....	25
Fan Blade Setting Dimensions .....	26
Refrigerant Charge .....	26
Pressure Charts .....	27
Optional Accessories .....	28

## Tables

Table 1	Factory Built-In Electric Heat Table .....	2
Table 2	Electrical Specifications .....	3
Table 2A	Electrical Specifications .....	4
Table 3	Operating Voltage Range .....	13
Table 4	Wall Thermostats and Subbase Combinations .....	14
Table 5	Troubleshooting .....	24
Table 6	Temperature vs Resistance of Temperature Sensor .....	25
Table 7	Fan Blade Dimensions .....	26
Table 8	Suction Line Temperatures .....	26
Table 9	Indoor Blower Performance .....	26
Table 10	Cooling Pressure .....	27
Table 11	Heating Pressure .....	28

# Getting Other Information and Publications

---

These publications can help you install the air conditioner or heat pump. You can usually find these at your local library or purchase them directly from the publisher. Be sure to consult current edition of each standard.

National Electrical Code ..... ANSI/NFPA 70

Standard for the Installation ..... ANSI/NFPA 90A  
of Air Conditioning and  
Ventilating Systems

Standard for Warm Air ..... ANSI/NFPA 90B  
Heating and Air  
Conditioning Systems

Load Calculation for ..... ACCA Manual J or  
Winter and ..... Manual N  
Summer Air Conditioning

Low Pressure, Low Velocity Duct ..... ACCA Manual D or  
System Design for Winter and ..... Manual Q  
Summer Air Conditioning

## For more information, contact these publishers:

**ACCA — Air Conditioning Contractors of America**  
1712 New Hampshire Avenue  
Washington, DC 20009  
Telephone: (202) 483-9370  
Fax: (202) 234-4721

**ANSI — American National Standards Institute**  
11 West Street, 13th Floor  
New York, NY 10036  
Telephone: (212) 642-4900  
Fax: (212) 302-1286

**ASHRAE — American Society of Heating  
Refrigerating, and  
Air Conditioning Engineers, Incorporated**  
1791 Tullie Circle, N.E.  
Atlanta, GA 30329-2305  
Telephone: (404) 636-8400  
Fax: (404) 321-5478

**NFPA — National Fire Protection Association**  
Batterymarch Park  
P.O. Box 9101  
Quincy, MA 02269-9901  
Telephone: (800) 344-3555  
Fax: (617) 984-7057

# QTec Series General Information

## QTec Model Nomenclature

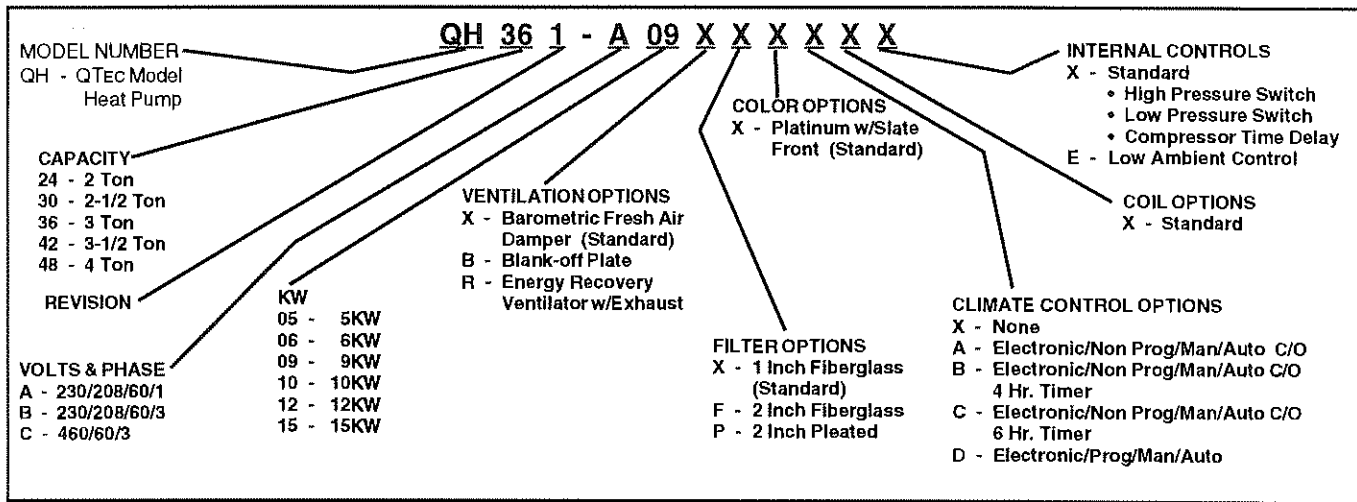

TABLE 1 – FACTORY BUILT-IN ELECTRIC HEAT TABLE

MODELS	QH241-A QH301-A		QH241-B		QH301-B		QH241-C	QH301-C	QH361-A QH421-A QH481-A		QH361-B QH421-B QH481-B		QH361-C QH421-C QH481-C
	240V-1	208V-1	240V-1	208V-1	240V-1	208V-1	480V-3	480V-3	240V-1	208V-1	240V-1	208V-1	480V-3
KW	BTUH	BTUH	BTUH	BTUH	BTUH	BTUH	BTUH	BTUH	BTUH	BTUH	BTUH	BTUH	BTUH
5.0	16,380	12,290							16,380	12,290			
6.0			20,500	15,360	20,500	15,360	20,500	20,500			20,500	15,360	20,500
9.0			30,700	23,000	30,700	23,000	30,700	30,700			30,700	23,000	30,700
10.0	32,670	24,570							32,670	24,570			
12.0					41,000	30,700		41,000					
15.0									49,150	36,860	49,150	36,860	49,150

**TABLE 2 ELECTRICAL SPECIFICATIONS**

MODEL	RATED VOLTS & PHASE	SINGLE CIRCUIT					DUAL CIRCUIT							
		NO. FIELD POWER CIRCUITS	③ MINIMUM CIRCUIT AMPACITY	① MAXIMUM EXTERNAL FUSE OR CIRCUIT BREAKER	② FIELD POWER WIRE SIZE	② GROUND WIRE SIZE	③ MINIMUM CIRCUIT AMPACITY		① MAXIMUM EXTERNAL FUSE OR CIRCUIT BREAKER		② FIELD POWER WIRE SIZE		② GROUND WIRE SIZE	
							CKT. A	CKT. B	CKT. A	CKT. B	CKT. A	CKT. B	CKT. A	CKT. B
QH241-A0Z -A05 -A10	230/208-1	1 1 1 OR 2	22 47 72	30 50 80	10 8 4	10 10 8	22	50	30	50	10	8	10	10
QH241-B0Z -B06 -B09	230/208-3	1 1 1	17 35 44	20 35 45	12 8 8	12 10 10								
QH241-C0Z -C06 -C09	460-3	1 1 1	8 17 22	15 20 25	14 12 10	14 12 10								
QH301-A0Z -A05 -A10	230/208-1	1 1 1 OR 2	24 49 74	35 50 80	8 8 4	10 10 8	24	50	30	50	10	8	10	10
QH301-B0Z -B06 -B09 -B12	230/208-3	1 1 1 1	18 36 45 54	25 40 45 60	10 8 6 6	10 10 10 10								
QH301-C0Z -C06 -C09 -C12	460-3	1 1 1 1	9 18 23 27	15 20 25 30	14 12 10 8	14 12 10 10								
QH361-A0Z -A05 -A10 ④ -A15	230/208-3	1 1 1 OR 2 1 OR 2	29 54 79 82	35 60 90 90	8 6 4 4	10 10 8 8	29 32	50 50	40 40	50 50	8 8	8 8	10 10	10 10
QH361-B0Z -B06 -B09 ⑤ -B15	230/208-3	1 1 1 1	23 41 50 52	30 45 50 60	10 8 8 6	10 10 10 10								
QH361-C0Z -C06 -C09 ⑤ -C15	460-3	1 1 1 1	11 20 24 26	15 20 30 30	14 10 10 10	14 10 10 10								

- ① Maximum size of the time delay fuse or HACR type circuit breaker for protection of field wiring conductors.
- ② Based on 75° C copper wire. All wiring must conform to the National Electrical Code and all local codes.
- ③ These "Minimum Circuit Ampacity" values are to be used for sizing the field power conductors. Refer to the National Electric Code (latest revision), article 310 for power conductor sizing. CAUTION: When more than one field power conductor circuit is run through one conduit, the conductors must be derated. Pay special attention to Note 8 of Table 310 regarding Ampacity Adjustment Factors when more than three conductors are in a raceway.
- ④ Maximum KW that can operate with heat pump on is 10KW. Other 5KW energizes during emergency heating only.
- ⑤ Maximum KW that can operate with heat pump on is 9KW. Other 6KW energizes during emergency heating only.

**ELECTRICAL SPECIFICATIONS Continued on Page 4 TABLE 2A**

TABLE 2A ELECTRICAL SPECIFICATIONS (continued from Page 3)

MODEL	RATED VOLTS & PHASE	SINGLE CIRCUIT					DUAL CIRCUIT							
		NO. FIELD POWER CIRCUITS	③ MINIMUM CIRCUIT AMPACITY	① MAXIMUM EXTERNAL FUSE OR CIRCUIT BREAKER	② FIELD POWER WIRE SIZE	② GROUND WIRE SIZE	③ MINIMUM CIRCUIT AMPACITY		① MAXIMUM EXTERNAL FUSE OR CIRCUIT BREAKER		② FIELD POWER WIRE SIZE		② GROUND WIRE SIZE	
							CKT. A	CKT. B	CKT. A	CKT. B	CKT. A	CKT. B	CKT. A	CKT. B
QH421-A0Z -A05 -A10 ④ -A15	230/208-1	1	33	50	8	10	--	--	--	--	--	--	--	--
		1	58	60	6	10	--	--	--	--	--	--	--	--
		1 OR 2	83	90	4	8	33	50	40	50	8	8	10	10
		1 OR 2	83	90	4	8	33	50	40	50	8	8	10	10
QH421-B0Z -B06 -B09 ⑤ -B15	230/208-3	1	22	30	10	10	--	--	--	--	--	--	--	--
		1	43	45	8	10	--	--	--	--	--	--	--	--
		1	52	60	6	10	--	--	--	--	--	--	--	--
		1	52	60	6	10	--	--	--	--	--	--	--	--
QH421-C0Z -C06 -C09 ⑤ -C15	460-3	1	16	20	12	12	--	--	--	--	--	--	--	--
		1	25	25	10	10	--	--	--	--	--	--	--	--
		1	30	30	10	10	--	--	--	--	--	--	--	--
		1	30	30	10	10	--	--	--	--	--	--	--	--
QH481-A0Z -A05 -A10 ④ -A15	230/208-1	1	36	60	6	10	--	--	--	--	--	--	--	--
		1	61	70	4	8	36	25	50	25	8	10	10	10
		1 OR 2	86	100	2	6	36	50	50	50	8	8	10	10
		1 OR 2	86	100	2	6	36	50	50	50	8	8	10	10
QH481-B0Z -B05 -B10 ⑤ -B15	230/208-3	1	26	40	8	10	--	--	--	--	--	--	--	--
		1	44	50	8	10	--	--	--	--	--	--	--	--
		1	53	60	6	10	--	--	--	--	--	--	--	--
		1	53	60	6	10	--	--	--	--	--	--	--	--
QH481-C0Z -C06 -C09 ⑤ -C15	460-3	1	14	15	14	14	--	--	--	--	--	--	--	--
		1	23	25	10	10	--	--	--	--	--	--	--	--
		1	27	30	10	10	--	--	--	--	--	--	--	--
		1	27	30	10	10	--	--	--	--	--	--	--	--

- ① Maximum size of the time delay fuse or HACR type circuit breaker for protection of field wiring conductors.
- ② Based on 75° C copper wire. All wiring must conform to the National Electrical Code and all local codes.
- ③ These "Minimum Circuit Ampacity" values are to be used for sizing the field power conductors. Refer to the National Electric Code (latest revision), article 310 for power conductor sizing. CAUTION: When more than one field power conductor circuit is run through one conduit, the conductors must be derated. Pay special attention to Note 8 of Table 310 regarding Ampacity Adjustment Factors when more than three conductors are in a raceway.
- ④ Maximum KW that can operate with heat pump on is 10KW. Other 5KW energizes during emergency heating only.
- ⑤ Maximum KW that can operate with heat pump on is 9KW. Other 6KW energizes during emergency heating only.

FIGURE 1 - UNIT DIMENSIONS

DIMENSION CHART					
UNIT	DIM. A	DIM. B	DIM. C	DIM. D	DIM. E
QH241					
QH301	7.625	42.000	30.000	30.000	43.000
QH361					
QH421	10.625	48.000	36.000	36.000	49.000

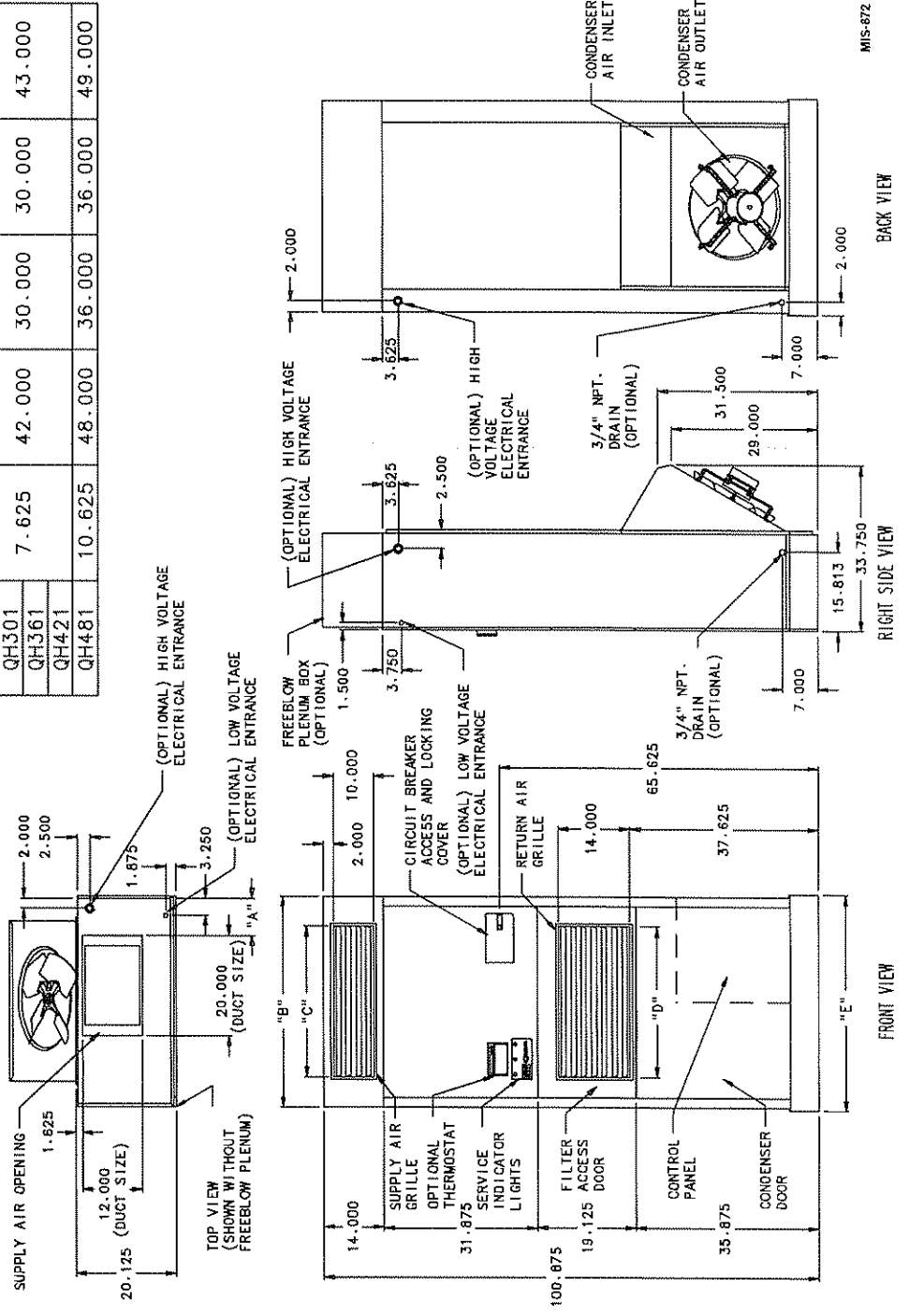

MIS-872

## SHIPPING DAMAGE

Upon receipt of equipment, the carton should be checked for external signs of shipping damage. The skid must remain attached to the unit until the unit is ready for installation. If damage is found, the receiving party must contact the last carrier immediately, preferably in writing, requesting inspection by the carrier's agent.

## UNIT REMOVAL FROM SKID

### **WARNING**

This unit is heavy and requires more than one person to handle and remove from the skid. Check unit wheels to ensure that wheels are locked before removing from skid. Extreme caution must be taken to prevent injury to personnel and damage to the unit.

It is recommended that the unit not be removed from the skid with a fork lift since the air seal under the unit could be damaged. See Figure 2.

The shipping brackets on each side of the unit must be removed and discarded. See Figure 3-A. The return air grille panel can be removed to provide a place to hold the unit. The unit can be slid forward on the skid until the front

FIGURE 2

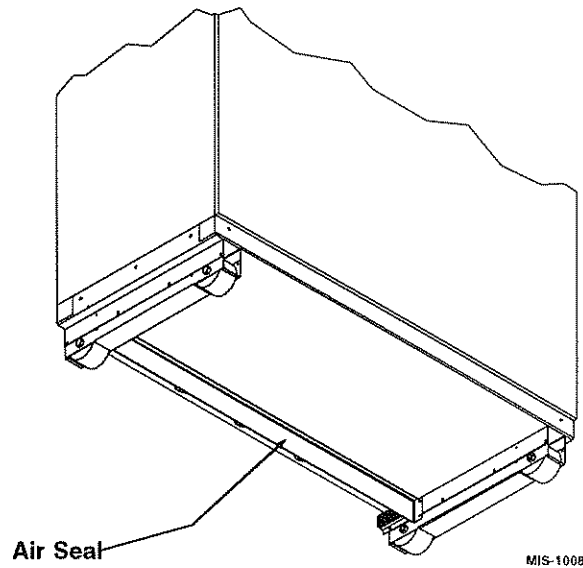

wheels hang over the edge of the skid. See Figure 3-B. The unit can be tipped forward and slid down the edge of the skid until the front wheels touch the ground. See Figure 3-C. The wheels will not roll. They are shipped from the factory locked so they will not roll. The back of the skid will have to be held down to keep it from tipping up. The skid can be slid out from under the unit. The unit can then be set upright.

FIGURE 3

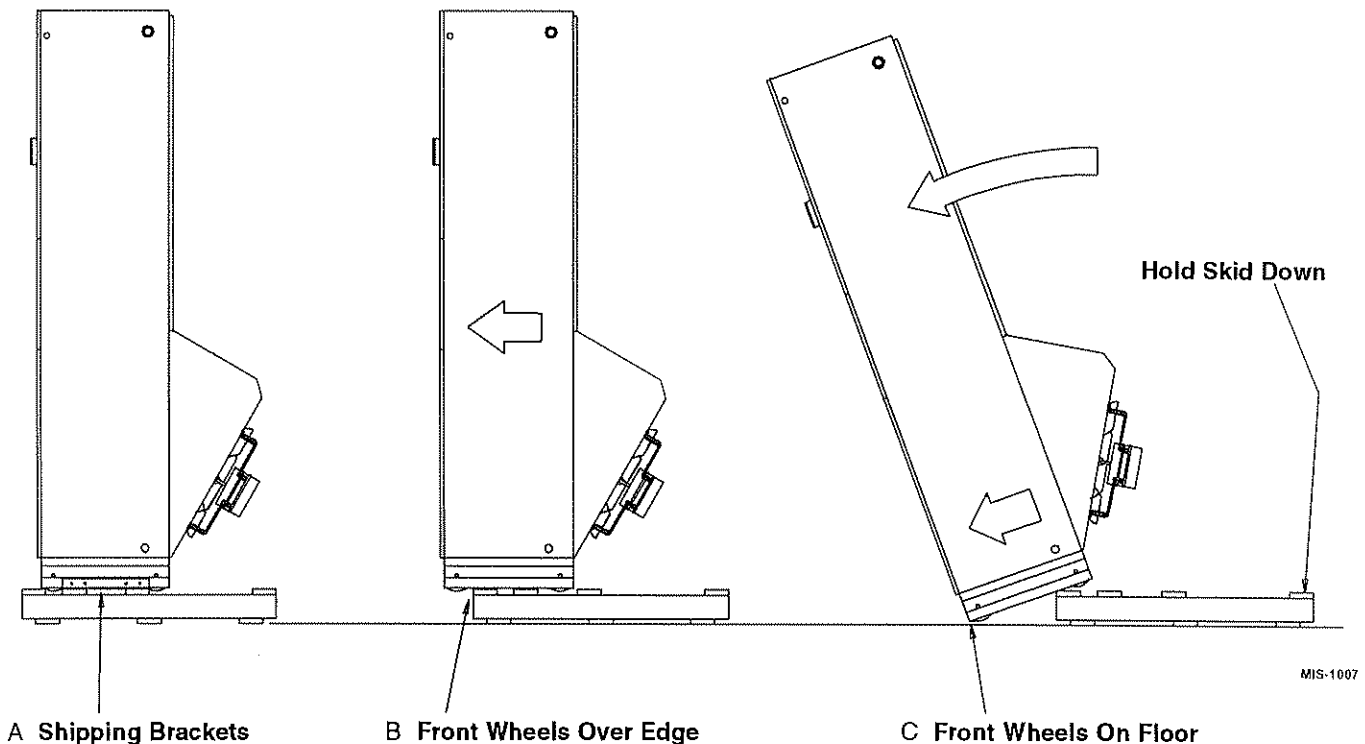



## HANDLING UNIT AFTER REMOVAL FROM SKID

### WARNING

Exercise extreme caution when pushing the unit on the rollers. Handle and push from the lower 1/3 of the unit. Insure that debris is not on the floor where the unit is to be moved on the rollers. Failure to do so could result in the unit tipping over and causing bodily injury and/or damage to the unit.

The unit will have to be turned sideways and removed from the skid to fit through a 36" doorway. If the door height allows, the unit can be slid sideways through the door.

If the unit can not be slid through the door, then the unit will have to be put on a cart and tipped down to roll through the door. It is recommended that an appliance cart be used with a strap to hold the unit on the cart. The wheels of the unit must be locked. If the wheels were allowed to roll, the unit could roll off the cart. The unit should always be carted from the left side. This is the side where the compressor is located. See Figure 4. The blade of the appliance cart should be slid under the wheels of the unit. The strap of the appliance cart should be placed around the unit and strapped tightly. Help will be required to tip the unit back onto the cart. The unit can be leaned far enough back to be rolled through the door. Be careful when setting the unit back up to keep from damaging the unit.

FIGURE 4

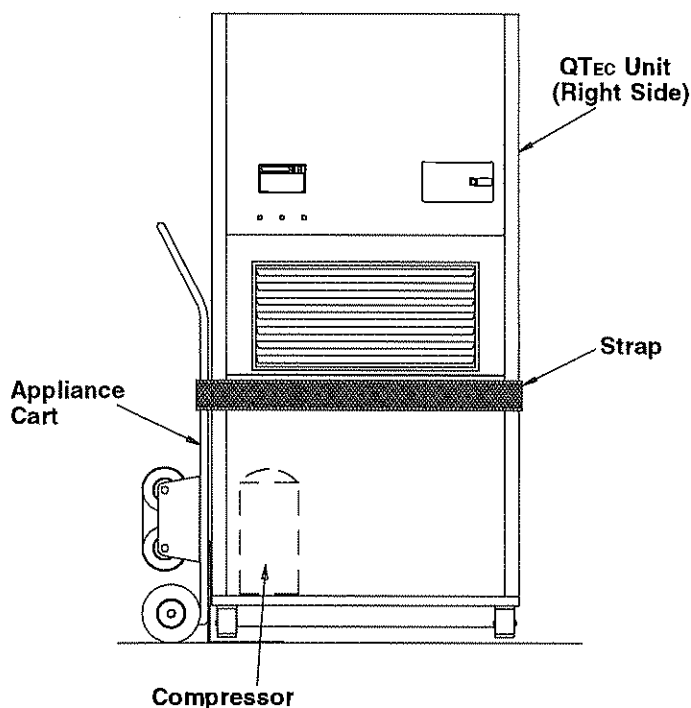

MIS-1006

## GENERAL

The equipment covered in this manual is to be installed by trained, experienced service and installation technicians.

The unit is designed for use with or without duct work. For use without duct work, Plenum Box QPB\*\* is recommended.

These instructions explain the recommended method to install the air cooled self-contained unit and the electrical wiring connections to the unit.

These instructions and any instructions packaged with any separate equipment required to make up the entire air conditioning system should be carefully read before beginning the installation. Note particularly "Start Procedure" and any tags and/or labels attached to the equipment.

While these instructions are intended as a general recommended guide, they do not supersede any national and/or local codes in any way. Authorities having jurisdiction should be consulted before the installation is made. See Page 1 for information on codes and standards.

Size of unit for a proposed installation should be based on heat loss calculation made according to methods of Air Conditioning Contractors of America (ACCA). The air duct should be installed in accordance with the Standards of the National Fire Protection Systems of Other Than Residence Type, NFPA No. 90A, and Residence Type Warm Air Heating and Air Conditioning Systems, NFPA No. 90B. Where local regulations are at a variance with instructions, installer should adhere to local codes.

## MINIMUM INSTALLATION HEIGHT

The minimum installation height of the unit with a Free Blow Plenum is 8 ft. 6 in. This provides enough clearance for the plenum to be removed. See Figure 5.

The minimum installation height for ducted applications is 8 ft. 4-1/2 in. This provides enough clearance to install the duct work. See Figure 6.

**FIGURE 5 – INSTALLATION WITH FREE BLOW PLENUM**

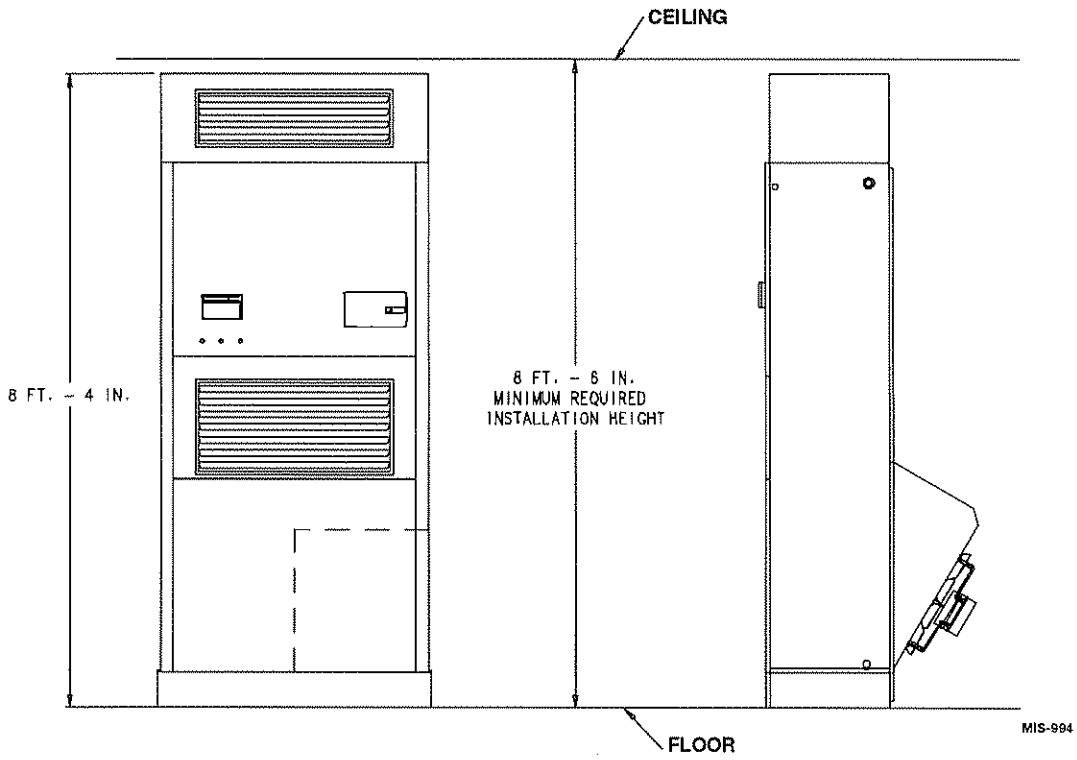

**FIGURE 6 – DUCTED APPLICATION**

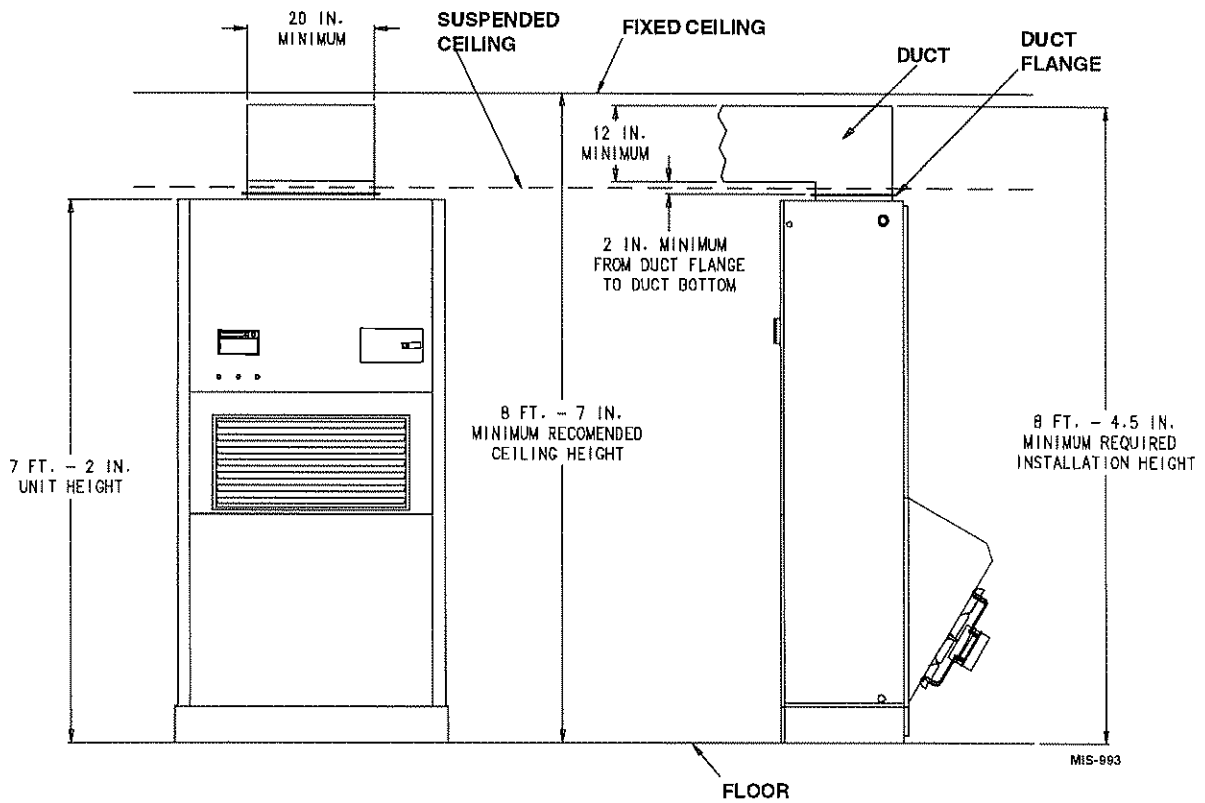

## DUCT WORK

Any heat pump is more critical of proper operating charge and an adequate duct system than a straight air conditioning unit. All duct work must be properly sized for the design air flow requirement of the equipment. Air Conditioning Contractors of America (ACCA) is an excellent guide to proper sizing. All duct work or portions thereof not in the conditioned space should be properly insulated in order to both conserve energy and prevent condensation or moisture damage. When duct runs through unheated spaces, it should be insulated with a minimum of one inch of insulation. Use insulation with a vapor barrier on the outside of the insulation. Flexible joints should be used to connect the duct work to the equipment in order to keep the noise transmission to a minimum.

The QTec series heat pump has provision to attach a supply air duct to the top of the unit. Duct connection size is 12 inches x 20 inches. The duct work is field supplied and must be attached in a manner to allow for ease of removal when it becomes necessary to slide the unit out from the wall for service. See Figure 7 for suggested attachment method.

*NOTE: Unit cabinet, supply air duct and free blow plenum are approved for "0" clearance to combustible material.*

**FIGURE 7 – SUPPLY DUCT CONNECTIONS**

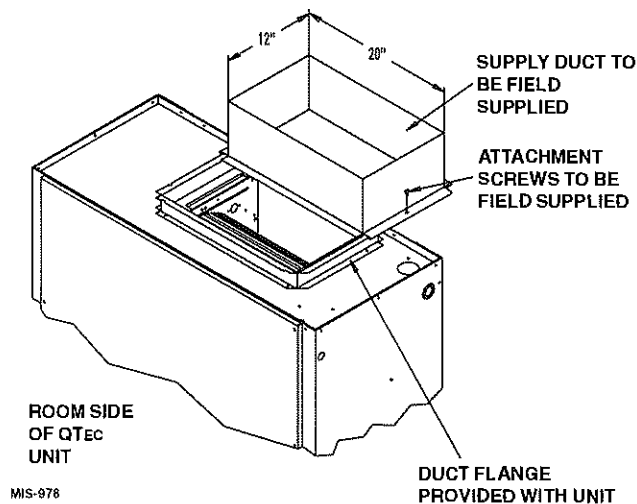

The QTec series heat pumps are designed for use with free return (non-ducted) and either free blow with the use of QPB Plenum Box or a duct supply air system.

The QPB Plenum Box mounts on top of the unit and has both vertically and horizontally adjustable louvers on the front discharge grille. See Optional Accessories, Page 25, for the correct Plenum Box model number.

When used with a ducted supply, a QCX Cabinet Extension can be used to conceal the duct work above the unit to the ceiling. This extends 20" above the unit for a total height above the floor of 10'-7/8". See Optional Accessories, Page

25, for the correct Cabinet Extension model number. The unit is equipped with a variable speed indoor blower motor which increases in speed with an increase in duct static pressure. The unit will therefore deliver proper rated air flow up to the Maximum ESP shown in Table 9. However, for quiet operation of the air system, the duct static should be kept as low as practical, within the guidelines of good duct design.

## FILTERS

Two 1 inch throw away filters are supplied with each unit. An indicator light on the front exterior panel of the unit will be lit when the filters require service. The filters fit into a rack that slides into position. Refer to Figure 8.

The filters are serviced from the inside of the building by removing the return air grille panel. This panel is attached by four (4) 1/4 turn fasteners. The return air grille panel is equipped with a door switch that will shut the unit down while the filters are being serviced.

Once the filters are replaced, the dirty filter sensor must be reset to turn the indicator light off. The sensor is located on the right side of the unit just below the filter rack. See Figure 8. The knob on the front of the sensor should be turned clockwise to reset the sensor.

The internal filter brackets are adjustable to accommodate 2 inch filters. The tabs for the 1 inch filters must be bent down to allow the 2 inch filters to slide in place.

**FIGURE 8 – FILTER LOCATION**

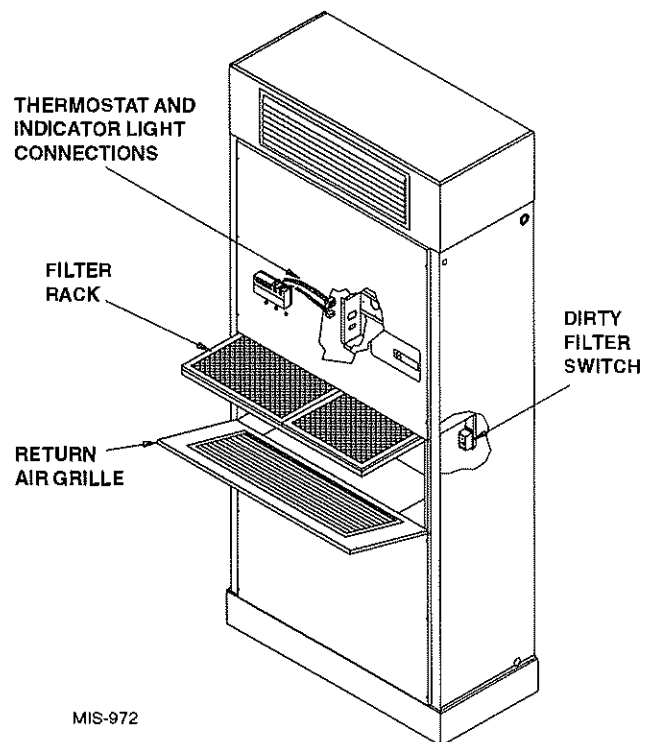

## DIRTY FILTER SWITCH ADJUSTMENT

The dirty filter switch is located on the right side of the unit below the filter rack. The dirty filter switch alerts the user to a dirty filter by turning on the light in the front panel of the unit.

The dirty filter switch can be adjusted by turning the screw on the front of the switch. This must be done with the blower running and the filters in place. The desired restriction should be placed on the filters. This can be done by placing pieces of paper on the filters until the appropriate amount of the filters are covered. The recommended restriction is 75%. If the dirty filter flag appears in the window of the filter switch, turn the screw one turn clockwise and reset the filter switch. This should be repeated until the dirty filter flag does not appear in the filter switch window after it has been reset. Slowly turn the screw counterclockwise until the dirty filter flag appears in the filter switch window. Be sure to remove the restriction before putting the unit back into service.

## FRESH AIR INTAKE

The fresh air damper assembly is standard equipment with the unit because of the variety of state or local codes requiring fresh air capability. It is shipped already attached to each unit.

All capacity, efficiency and cost of operation information as required for Department of Energy "Energyguide" Fact Sheets is based upon the fresh air blank-off plate in place and is recommended for maximum energy efficiency.

The blank-off plate is available upon request from the factory and is installed in place of the fresh air damper shipped with each unit.

On all 208/230 volt models, when G circuit is de-energized the indoor blower motor will continue to run for one minute.

For details on energy recovery ventilation see separate section.

## CONDENSATE DRAIN

There are two drain connections on the unit. The side drain is located on the bottom right side of the unit. The rear drain is an optional drain, and is located on the right lower rear panel of the unit. The rear drain is shipped with a plug installed.

The *side drain* requires a water trap for proper drainage. See Figure 9. The drain can be routed through the floor or through the wall. *If the drain is to be routed through an unconditioned space, it must be protected from freezing.* The drain line must be able to be removed from the unit if it is necessary to remove the unit from the wall.

FIGURE 9 – SIDE DRAIN (SIDE VIEW)

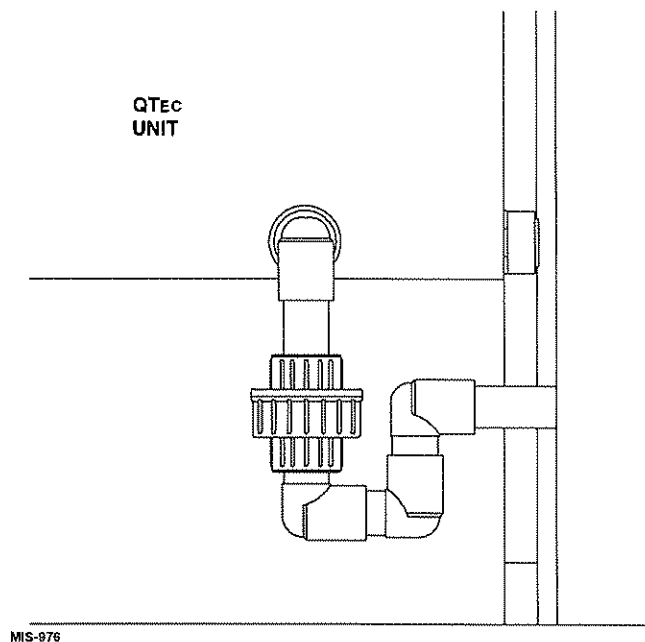

MIS-976

The *rear drain* can be used with wall thickness of up to 10 inches where a water trap can be installed between the unit and the interior wall. See Figure 10. The trap cannot extend beyond the edge of the unit or it will interfere with the wall mounting bracket. When the rear drain is used, the plug must be removed and installed in the side drain. The drain can be routed through the floor or through the wall. If the drain is routed through the wall, the drain line must be positioned such that it will not interfere with the sleeve flange or the grille. See Figure 11. *If the drain is to be routed through an unconditioned space, it must be protected from freezing.*

FIGURE 10 – OPTIONAL REAR DRAIN

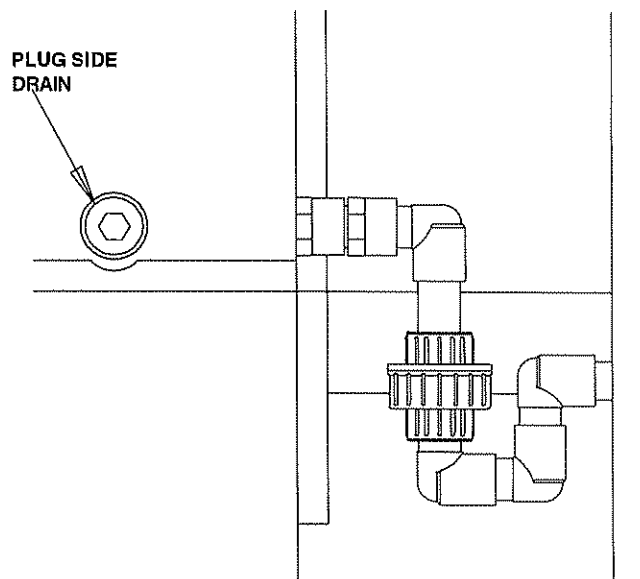

MIS-975

**FIGURE 11 – REAR DRAIN (TOP VIEW)**

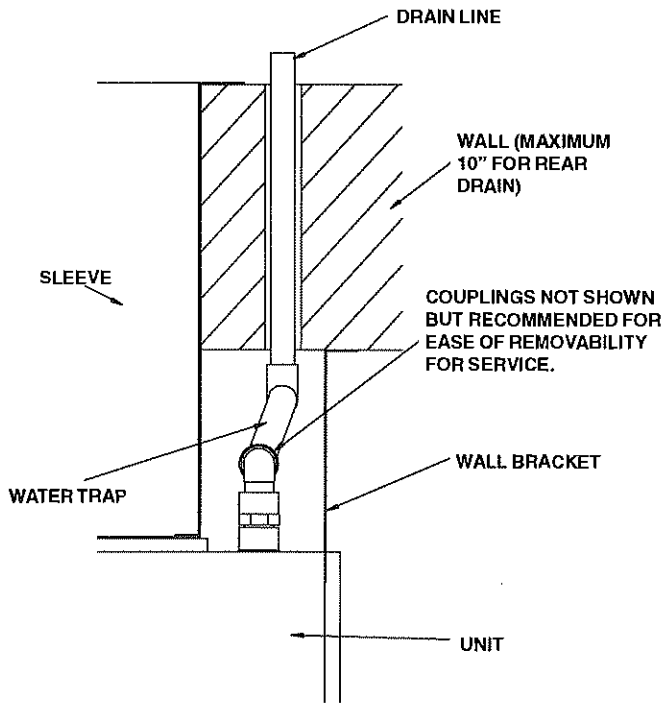

MIS-977

**SERVICE LIGHTS**

The unit is equipped with three service lights which signal the user that service is required. These lights are labeled Service Drain, Service Filter, and Service Unit. See Figure 14.

The *Service Drain* light indicates that there is water in the secondary drain pan and that the primary drain must be checked. This also shuts the unit off so that no additional water will be added which would cause the drain pan to overflow.

The *Service Filter* light indicates that the filters need to be changed. See the Filter section of this manual for service procedure.

The *Service Unit* light indicates that the unit has been shut off by a refrigerant control device. This indicates that the unit needs to be serviced.

**FIGURE 12 – UNIT MOUNTING**  
(Refer to Installation Instructions, Page 12)

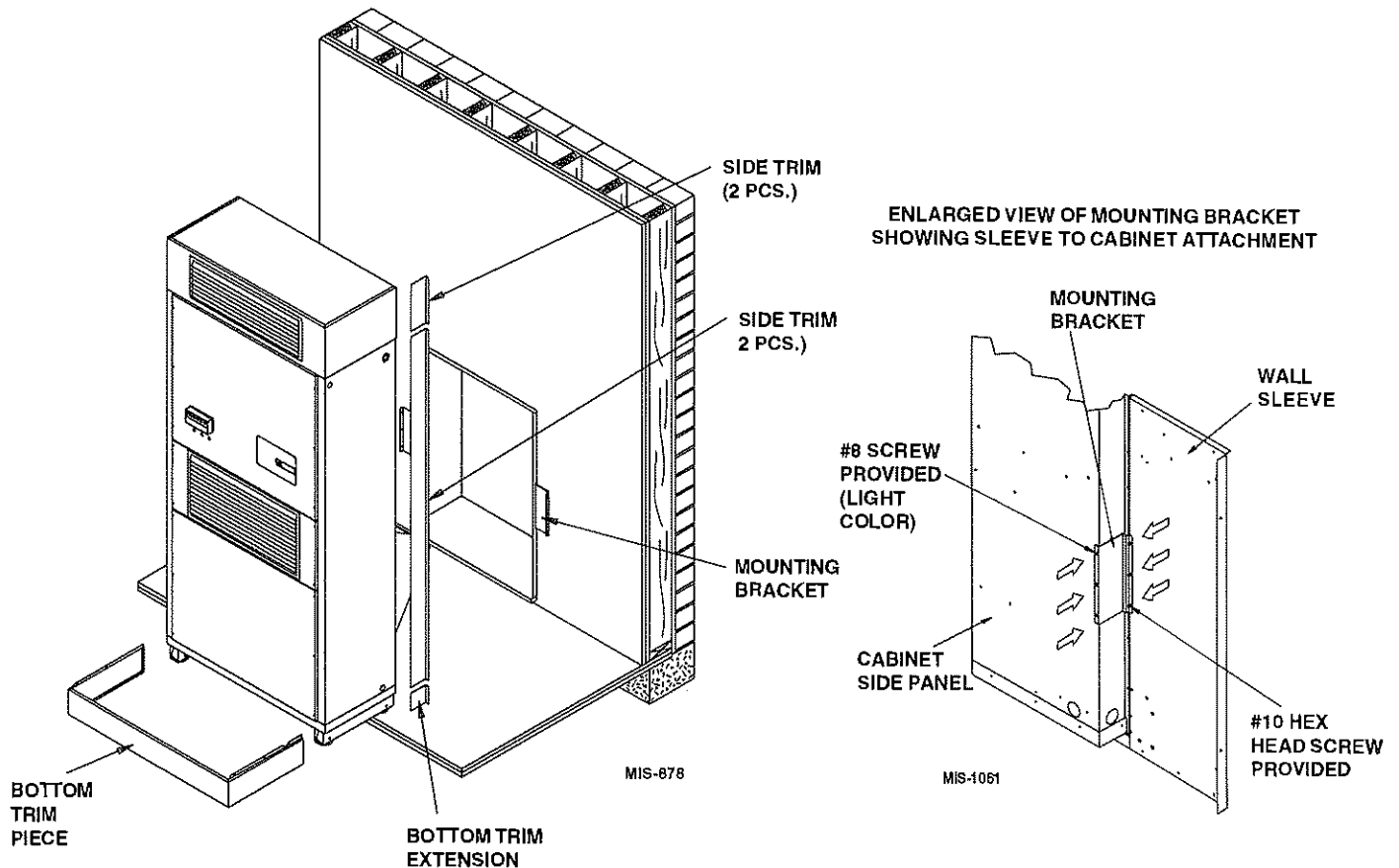

# Installation Instructions

## MOUNTING THE UNIT

When installing a QTEC unit near an interior wall on the left side, a minimum of 8 inches is required; 12 inches is preferred.

When installing a QTEC unit near an interior wall on the right side, a minimum of 12 inches is required as additional space is required to connect the side drain. If the rear condensate drain kit QCDS48 is used the minimum can be reduced to 8 inches.

This clearance is required to allow for the attachment of the unit to the sleeve and side trim pieces to the wall.

This unit is to be secured to the wall sleeve with mounting brackets provided. The unit itself, the supply duct, and the free blow plenum are suitable of "0" clearance to combustible material.

Following are the steps for mounting the QTEC, for reference see Figure 12 (page 11).

1. Attach mounting brackets to the wall sleeve with screws provided.
2. Position the unit in front of the sleeve with the condenser section toward the sleeve.
3. Remove the locking screws from the wheels. Refer to Figure 13.

4. Roll the unit into the sleeve. Make sure to check both sides of the units as it is being rolled to keep it centered in the sleeve. Also check the alignment to the mounting brackets. The unit must be level from side to side. If any adjustments are necessary, shim up under the rollers with sheets of steel or any substance that is not affected by moisture.
5. Make sure the gasket on the rear of the unit is touching the sleeve across the top and down both sides. This is a rain water seal.
6. Secure the mounting brackets to the unit with screws provided, #10 hex head sheet metal screws.
7. Bottom trim extensions are provided for use when wall is less than 14 inches but greater than 12 inches. Secure to wall with screws (not provided).
8. Attach the bottom trim piece to the unit with the screws provided (dark colored).
9. Position side trim pieces to wall and attach with field supplied screws. There are two long pieces and two short pieces supplied. The long pieces are to enclose the gap behind the unit. The short pieces are to fill the gap behind the cabinet extension or the free blow plenum box. They may be cut to suit your ceiling height or overlap the unit side trim. There is sufficient length to trim up to a 10' 2" ceiling.

*NOTE: If the exterior wall thickness is less than 12 inches, a side trim extension piece kit, model QSTX42, is available.*

FIGURE 13

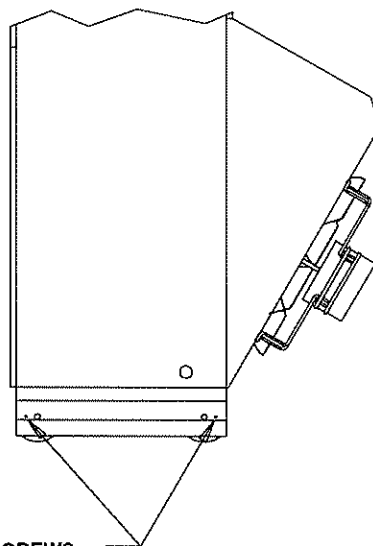

REMOVE SCREWS  
FROM WHEELS  
BEFORE ROLLING  
INTO PLACE

MIS-1018

## WIRING – MAIN POWER

Refer to the unit rating plate and/or Table 2 for wire sizing information and maximum fuse or “HACR Type” circuit breaker size. Each unit is marked with a “Minimum Circuit Ampacity”. This means that the field wiring used must be sized to carry that amount of current. Depending on the installed KW of electric heat, there may be two field power circuits required. If this is the case, the unit serial plate will so indicate. All models are suitable only for connection with copper wire. Each unit and/or wiring diagram will be marked “Use Copper Conductors Only”. These instructions **MUST BE** adhered to. Refer to the National Electrical Code (NEC) for complete current carrying capacity data on the various insulation grades of wiring material. All wiring must conform to NEC and all local codes.

The electrical data lists fuse and wire sizes (75° C copper) for all models, including the most commonly used heater sizes. Also shown are the number of field power circuits required for the various models with heaters.

The unit rating plate lists a “Maximum Time Delay Relay Fuse” or “HACR Type” circuit breaker that is to be used with the equipment. The correct size must be used for proper circuit protection, and also to assure that there will be no nuisance tripping due to the momentary high starting current of the compressor motor.

The disconnect access door on this unit may be locked to prevent unauthorized access to the disconnect.

See Start Up section for information on three phase scroll compressor start-ups.

FIGURE 14 – COMPONENT LOCATION

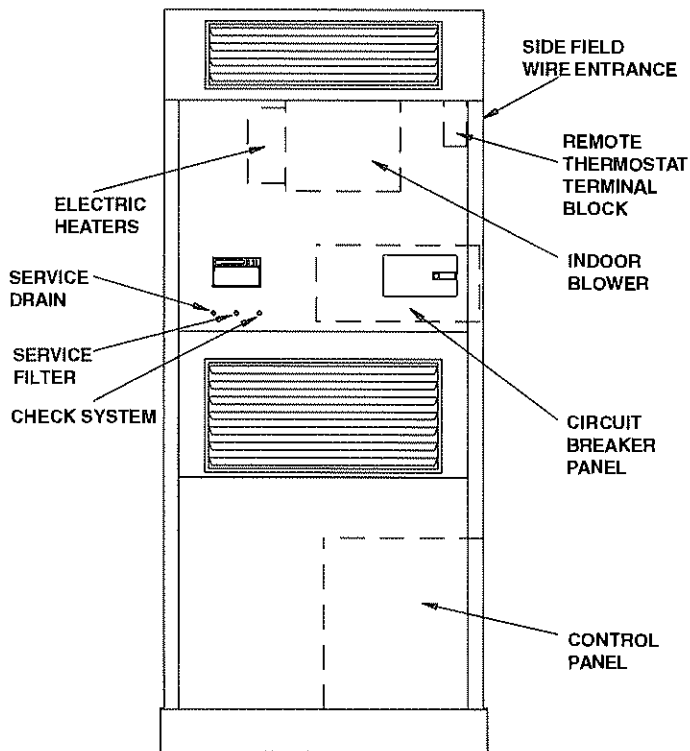

MIS-982

The field wiring connections are located behind the top panel in the circuit breaker panel. The return air panel must be removed first. This panel is equipped with a door switch which shuts the unit down when it is removed. The filter rack must be removed next. *The connections for the thermostat and the indicator lights must be disconnected before the top panel can be removed.* See Figure 14. The connections are located behind the top panel.

*The top panel should remain fastened to the unit until the connectors have been disconnected, or damage to the connectors may occur.* The locking tabs on either side of the connectors must be released. The connector can be pulled straight out of the socket. Once all the connectors have been removed, the top panel can be removed.

## WIRING – LOW VOLTAGE WIRING

### 230/208V, 1 PHASE AND 3 PHASE EQUIPMENT DUAL PRIMARY VOLTAGE TRANSFORMERS

All equipment leaves the factory wired on 240V tap. For 208V operation, reconnect from 240V to 208V tap. The acceptable operating voltage range for the 240 and 208V taps are as noted in Table 3.

TABLE 3 – OPERATING VOLTAGE RANGE

TAP	RANGE
240V	253 - 216
208V	220 - 187

**NOTE:** The voltage should be measured at the field power connection point in the unit and while the unit is operating at full load (maximum amperage operating condition).

The standard climate control option is a remote thermostat connection terminal block. See Figure 16 for wiring diagram. Compatible thermostats are listed in Table 4.

The Climate Control **Option A** is an electronic, non-programmable manual or auto change over thermostat. The sub base of the thermostat is factory wired to the front panel of the unit. Compatible for use with Bard CS2000 Controller and Energy Recovery Ventilator.

The Climate Control **Option B** is an electronic, non-programmable manual or auto change over thermostat and a four (4) hour timer. The sub base of the thermostat and the timer are factory wired to the front panel of the unit. Compatible for use with Energy Recovery Ventilator.

The Climate Control **Option C** is an electronic, non-programmable manual or auto change over thermostat and six (6) hour timer. The sub base of the thermostat and the timer are factory wired to the front panel of the unit. Compatible for use with Energy Recovery Ventilator.

The Climate Control **Option D** is an electronic, programmable thermostat. The sub base of the thermostat is factory wired to the front panel of the unit. Compatible for use with Energy Recovery Ventilator or Economizer.

FIGURE 15 -

THERMOSTAT PLUG  
TERMINALS P2 and P4

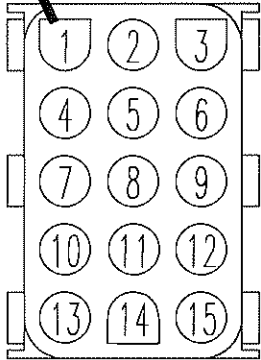

BLOWER MOTOR  
LOW VOLTAGE PLUG

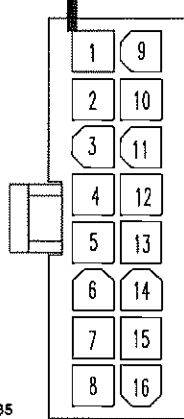

MIS-1285

TABLE 4 - WALL THERMOSTATS AND SUBBASE  
COMBINATIONS

Thermostat	Subbase	Predominant Features
8407-017 (T874R1129)	8404-009 (Q674L1181)	Heat or Cool No Auto
8403-018 (T874N2024)	8404-010 (Q6741261)	Automatic Heat/Cool Changeover Position
8403-034 (1F94-80)	N/A	Manual/Auto/Heat Cool Programmable Electronic
8403-042 (T8511G1070)	N/A	Manual/Auto/Heat/Cool Non-Programmable Electronic

FIGURE 16 - REMOTE THERMOSTAT WIRING DIAGRAM

"X" OPTION

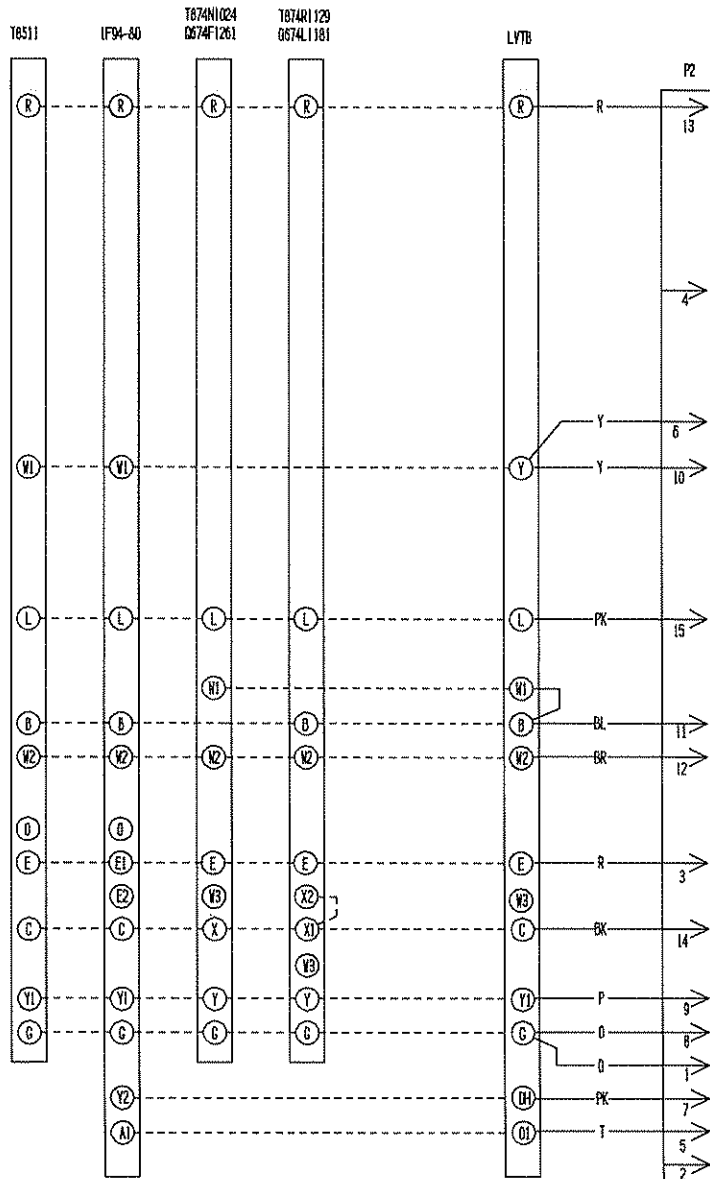

MIS-1284



**FIGURE 17 – REMOTE THERMOSTAT WIRING DIAGRAM  
“A” OPTION**

TB511

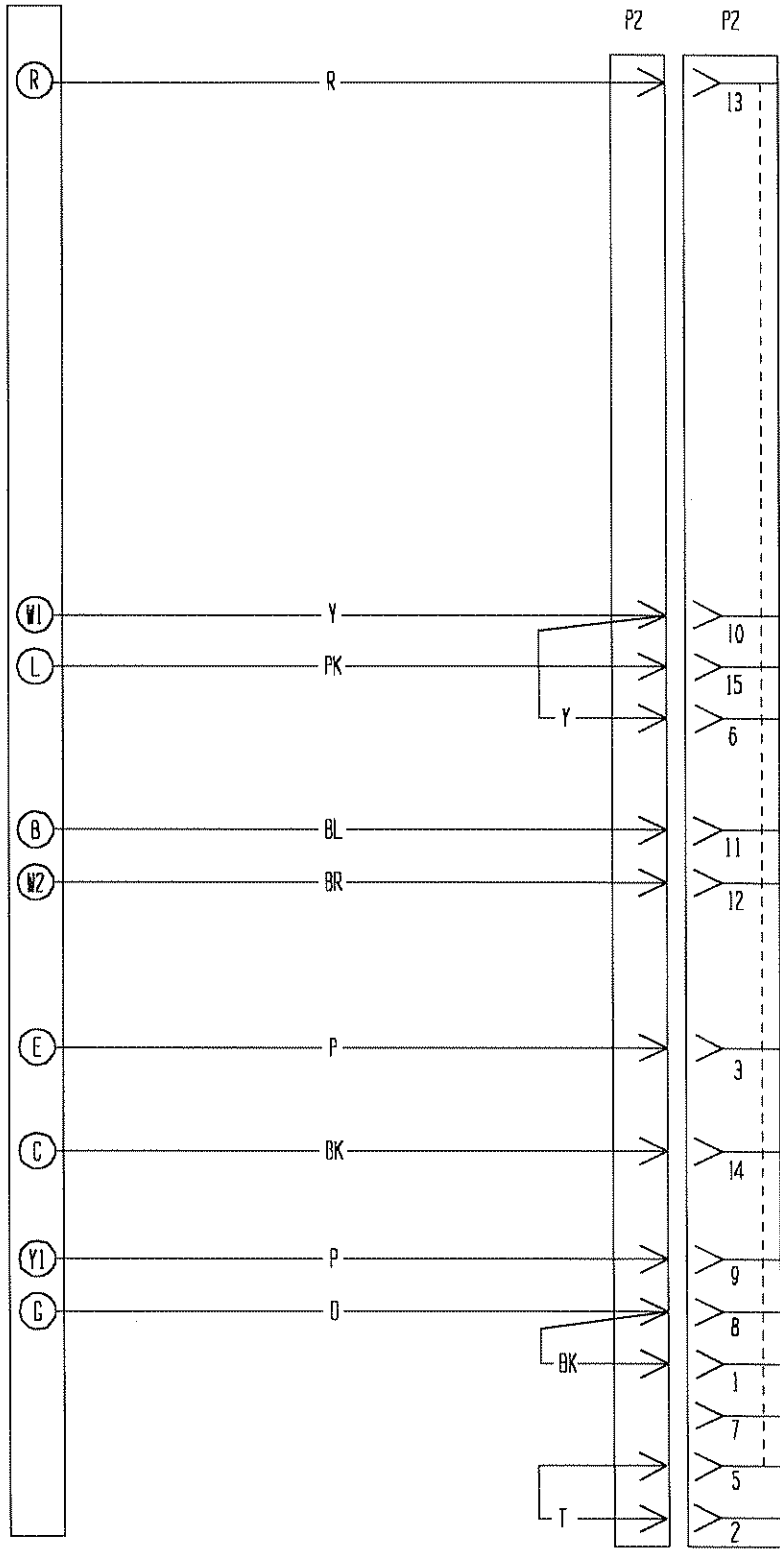

MIS-1293

**FIGURE 18 – REMOTE THERMOSTAT WIRING DIAGRAM  
“B” and “C” OPTIONS**

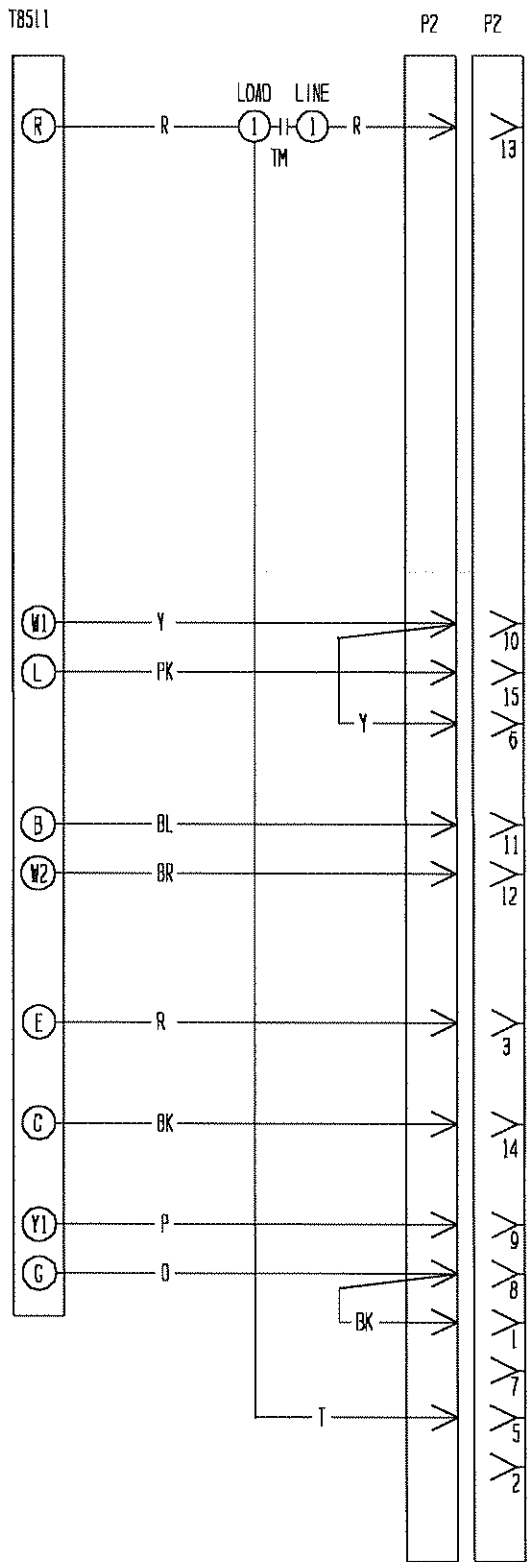

MIS-1294

**FIGURE 19 – REMOTE THERMOSTAT WIRING DIAGRAM  
“D” OPTION**

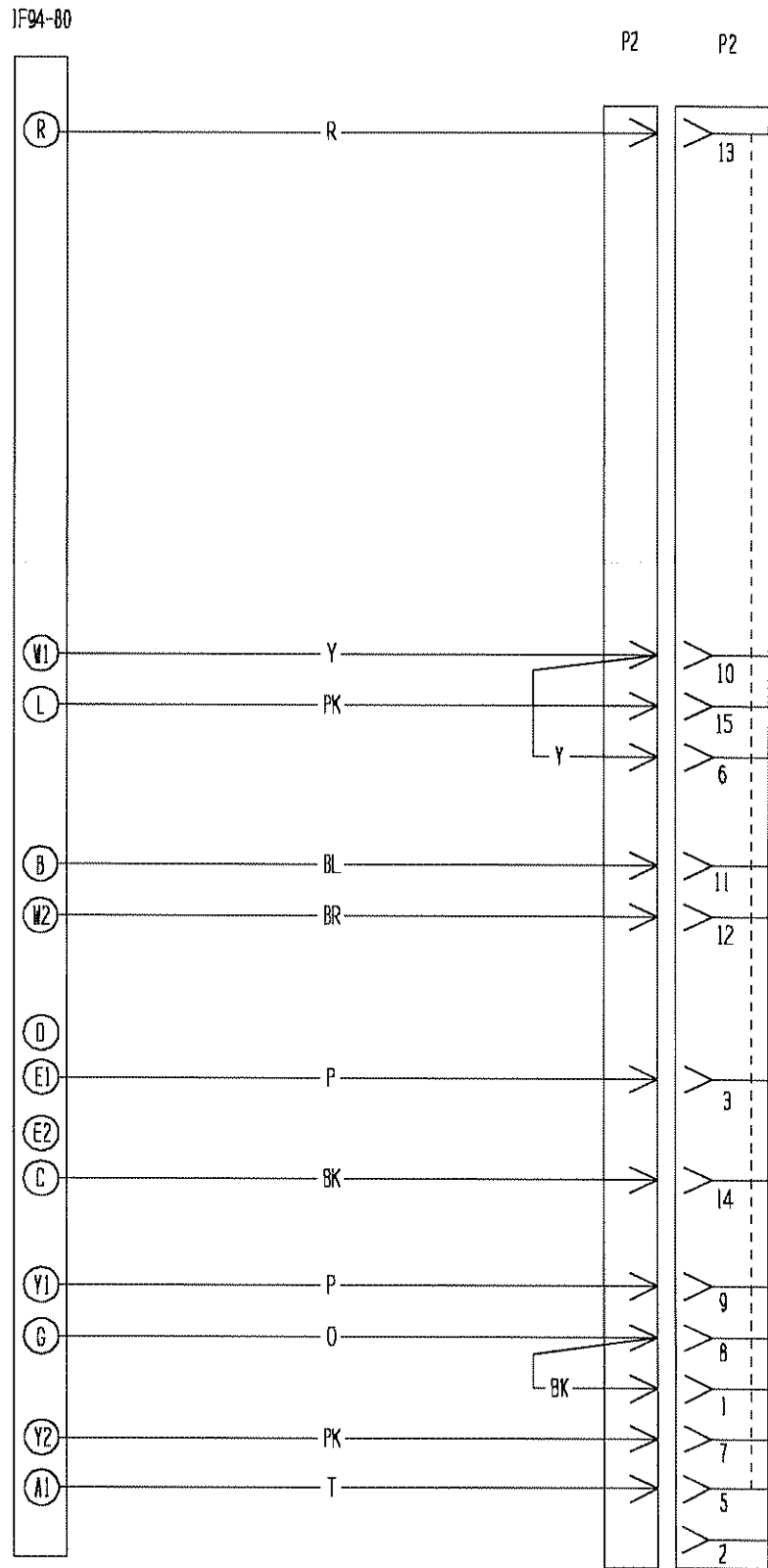

MIS-1292

# Start Up

---

## DESCRIPTION OF STANDARD EQUIPMENT

### ***Solid State Electronic Heat Pump Control***

Provides efficient 30 minute defrost cycle. A thermistor sensor and speed up terminal for service along with a 10 minute defrost override are standard on the electronic heat pump control.

### ***High / Low Pressure Switch***

Provides refrigerant circuit high pressure and loss of charge protection. Includes lockout circuit that is re-settable from room thermostat.

### ***Five Minute Compressor Time Delay***

Provides short cycle protection for the compressor which extends compressor life. Built into the electronic heat pump control as standard.

### ***Service Lights***

3 service lights indicate when service is required.

- Check System – detects high or low pressure switch operation for compressor protection.
- Service Filter – detects a dirty filter condition.
- Service Drain – detects a clogged drain by detecting water in the secondary drain system. Shuts system down until corrective action is taken.

### ***Two Speed Outdoor Motor***

Has two speeds and is controlled by an outdoor thermostat.

### ***Interlock Door Switch***

When the service door is removed, automatically shuts the unit down.

## OPTIONAL CFM (QH361, QH421 AND QH481 ONLY)

These units are shipped from the factory set to operate at the optional CFM level shown in Table 9. This provides lower operating sound levels for non-ducted, free discharge applications. This CFM level will reduce the system capacity performance by approximately 2% at the same energy efficiency.

Rated CFM is required for ducted applications for maximum performance rating. To obtain full CFM on these models, connect jumper wire as follows:

1. Disconnect all power to the unit. Failure to do so may result in damage to the motor.
2. Remove return air access panel.
3. Remove filter rack.
4. Unplug service lights and thermostat options. (See Figure 3.)
5. Remove upper door.
6. Remove inner control panel cover.
7. Add pink jumper wire (provided) to terminal 5 and 6 on the terminal board.
8. Reverse steps to reassemble.

## IMPORTANT INSTALLER NOTE

For improved start-up performance, wash the indoor coil with a dishwashing detergent.

## THREE PHASE SCROLL COMPRESSOR START UP INFORMATION

Scroll compressors, like several other types of compressors, will only compress in one rotational direction. Direction of rotation is not an issue with single phase compressors since they will always start and run in the proper direction.

However, three phase compressors will rotate in either direction depending upon phasing of the power. Since there is a 50-50 chance of connecting power in such a way as to cause rotation in the reverse direction, verification of proper rotation must be made. Verification of proper rotation direction is made by observing that suction pressure drops and discharge pressure rises when the compressor is energized. Reverse rotation also results in an elevated sound level over that with correct rotation, as well as, substantially reduced current draw compared to tabulated values.

***Verification of proper rotation must be made at the time the equipment is put into service.*** If improper rotation is corrected at this time there will be no negative impact on the durability of the compressor. However, reverse operation for over one hour may have a negative impact on the bearing due to oil pump out.

***NOTE: If compressor is allowed to run in reverse rotation for several minutes the compressor's internal protector will trip.***

All three phase scroll compressors used in the QTBC series are wired identically internally. As a result, once the correct phasing is determined for a specific system or installation, connecting properly phased power leads to the same Fusite terminal should maintain proper rotation direction. The direction of rotation of the motor may be changed by reversing any two line connections to the unit.

## SERVICE HINTS

1. Caution user to maintain clean air filters at all times. Also, not to needlessly close off supply air registers. This may reduce air flow through the system which shortens equipment service life as well as increasing operating costs and noise levels.
2. Switching to heating cycle at 75°F or higher outside temperature may cause a nuisance trip of the remote reset high pressure switch. Turn thermostat off, then on to reset the high pressure switch.
3. The heat pump wall thermostats perform multiple functions. Be sure that all function switches are correctly set for the desired operating mode before trying to diagnose any reported service problems.

4. Check all power fuses or circuit breakers to be sure they are the correct rating.
5. Periodic cleaning of the outdoor coil to permit full and unrestricted airflow circulation is essential.
6. Some service requires the need to remove the unit from the wall including replacement of the indoor coil and/or the outdoor coil. Also servicing the outdoor fan motor or fan blade installed at a height that is not easily accessible from the outside of the building.

In order to remove the unit from the wall the following procedure must be used:

- a. Turn off power to the unit at the remote location. Some units may have more than one power supply.
- b. Disconnect field wiring at unit terminal block and remove from unit.
- c. Disconnect condensate drain.
- d. Remove the lower skirting around the unit.
- e. Remove wall mounting brackets from wall on each side of the unit.
- f. If unit is attached to duct work, remove upper cabinet extension by removing the top center screw only from the cabinet side panel.
- g. Remove screws that attach the duct work to the unit flanges.

This unit is equipped with four rollers mounted to the base. For ease of pulling unit out from the wall, you may want to remove the bottom service door which requires removal of the return air panel, and grip the front flange of the base pan then pull straight out.

7. Annual maintenance is required to make sure that all of the systems are functioning properly.
  - a. Check to make sure that the drains are not obstructed in any way.
  - b. Check the water level switch operation.
  - c. Remove any debris in the condenser section of the unit.
  - d. Inspect and clean mist eliminator as necessary.
  - e. Inspect and wash outdoor coil as necessary.

## MIST ELIMINATOR SERVICE

A mist eliminator is supplied with the wall sleeve. The mist eliminator is constructed of an aluminum frame and mesh. The mist eliminator is located in the top section of the wall sleeve and can be removed from the inside of the building without removing the unit from the wall. This requires that the ventilation package must be removed.

It is recommended that the mist eliminator be inspected annually and serviced as required. The mist eliminator can be inspected from the outside of the building by looking through the outdoor grille. The mist eliminator can be

serviced from the outside by using a vacuum cleaner. The outdoor grille must be removed. Use the vacuum to remove dirt and debris from the surface of the mist eliminator. If additional cleaning is required, the mist eliminator will have to be removed from the sleeve.

The ventilation package will have to be removed to gain access to the mist eliminator. If the blank off plate option is used, it is not necessary to service the mist eliminator. The steps necessary to remove each of the vent options are listed below.

The mist eliminator can be cleaned by washing with soap and water. The excess water should be shaken off the mist eliminator before it is reinstalled.

## BAROMETRIC FRESH AIR DAMPER (Standard)

Before starting, make sure the power has been turned off. The return air grille panel must be removed. The fresh air damper assembly can be seen on the back of the unit. (Refer to Figure 20.)

1. The fresh air damper is attached to the back of the unit with one screw on either side of the assembly. Both of the screws must be removed.
2. Once the mounting screws are removed, tilt the assembly down and lift it out.

The mist eliminator can be seen through the opening. The mist eliminator must be raised up and the bottom can be pulled toward the front of the unit.

## ECONOMIZER (Option)

Before starting, make sure the power has been turned off. The return air grille panel must be removed. The economizer (ECON) can be seen after the panel has been removed.

1. The two mounting screws in the front of the ECON must be removed.
2. The power connectors for the ECON (located on the right side of the unit) must be disconnected. Squeeze the tabs on the sides of the connector and pull straight out. Unplug both of the connectors.
3. Slide the ECON straight out of the unit.

The mist eliminator can be seen through the opening in the back of the unit. The mist eliminator must be raised up and the bottom can be pulled toward the front of the unit and removed.

## COMMERCIAL ROOM VENTILATOR (Option)

Before starting, make sure the power has been turned off. The return air grille panel must be removed. The commercial room ventilator (CRV) can be seen after the panel has been removed. The CRV must be removed to gain access to the mist eliminator.

1. The two mounting screws in the front of the CRV must be removed.

2. The power connectors for the CRV (located on the right side of the unit) must be disconnected. Squeeze the tabs on the sides of the connector and pull straight out. Unplug both of the connectors.
3. Slide the CRV straight out of the unit.

The mist eliminator can be seen through the opening in the back of the unit. The mist eliminator must be raised up and the bottom can be pulled toward the front of the unit and removed.

### QTEC R ENERGY RECOVERY VENTILATOR (Option)

Before starting, make sure that the power has been turned off. The return air grille panel must be removed. The energy recovery ventilator (QERV) can be seen after the panel has been removed. To gain access to the mist eliminator, the QERV must be removed. (Refer to Figure 21.)

1. The front fill plate of the QERV must be removed. There is one screw on either side of the plate. Remove these screws and remove the plate.

**FIGURE 20  
FRESH AIR DAMPER REMOVAL**

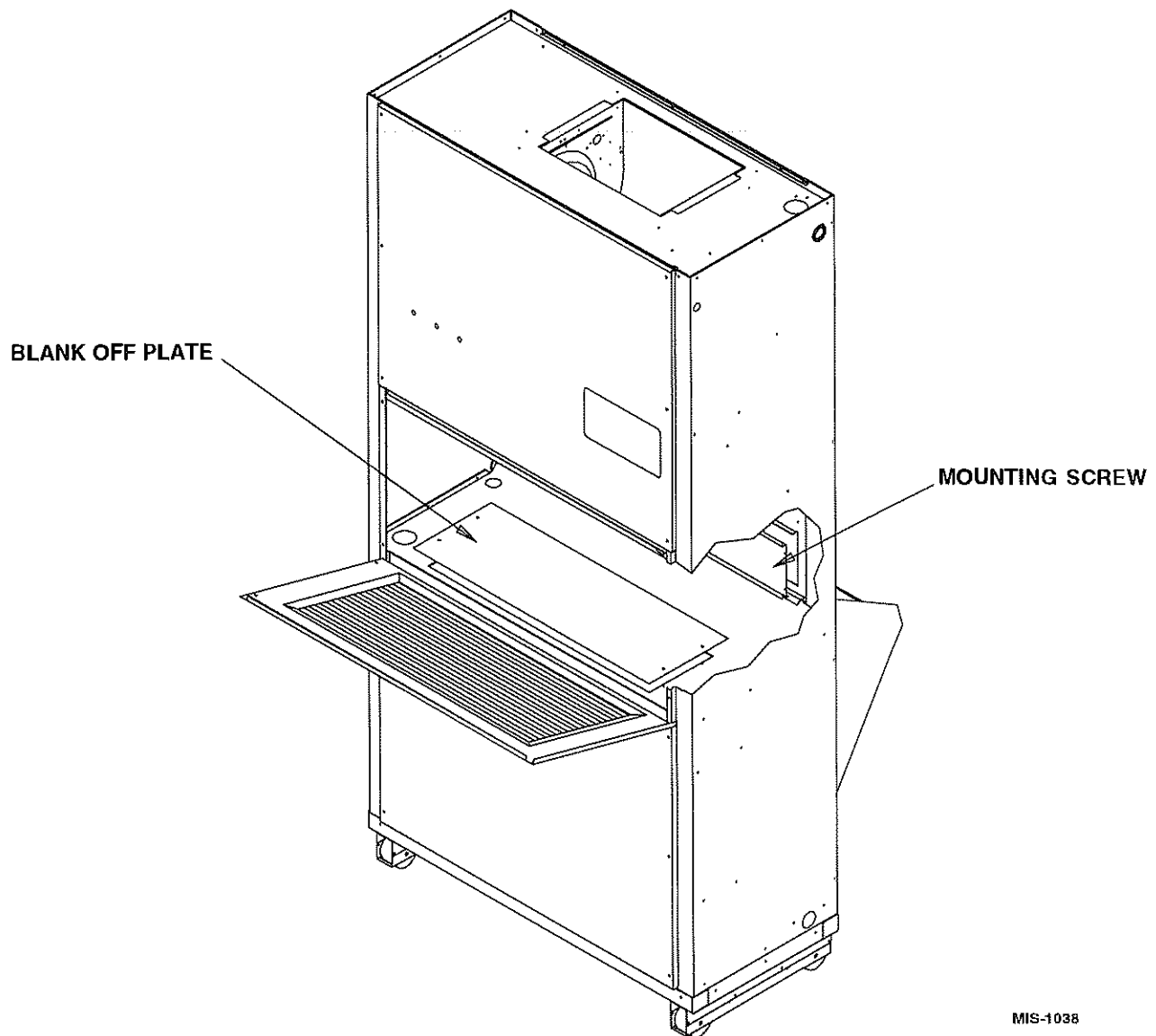

MIS-1038

2. On either side of the QERV there are mounting screws that hold the QERV in place. Remove both of these screws.
3. Underneath the heat recovery cassette there is a power connector for the lower blower assembly. To disconnect this plug, the tabs on both sides of the plug must be squeezed to release the plug. While squeezing the tabs, pull the plug out of the socket.
4. The QERV is plugged into the unit on the right side of the unit. Both of these plugs must be disconnected to remove the QERV. Squeeze the tabs on the sides of the connector and pull straight out.
5. Slide the QERV assembly straight out of the unit, being careful not to let the cassette slide out of the QERV.

The mist eliminator can be seen through the opening in the back of the unit. The mist eliminator must be raised up and the bottom can be pulled toward the front of the unit and removed.

**FIGURE 21  
QERV REMOVAL**

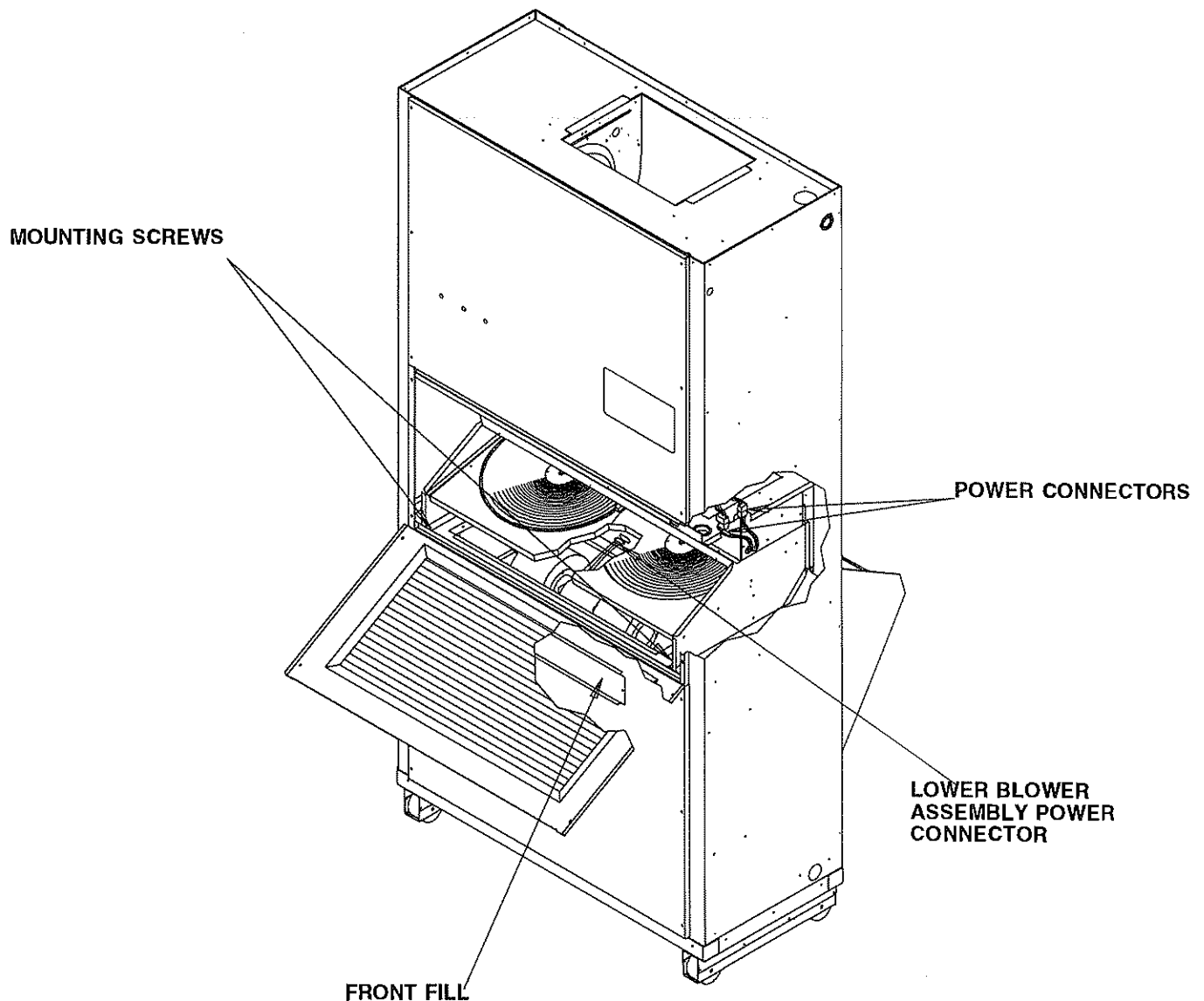

## SEQUENCE OF OPERATION

**Cooling** – Circuit R-Y makes the thermostat pull in the compressor contactor starting the compressor and outdoor motor. The G (indoor motor) circuit is automatically completed on any call for cooling operation, or can be energized by manual fan switch on subbase for constant air circulation.

**Heating** – A 24V solenoid coil on reversing valve controls heating cycle operation. Two thermostat options, one allowing “Auto” change over from cycle to cycle and the other constantly energizing solenoid coil during heating season and thus eliminating pressure equalization noise except during defrost, are to be used. On “Auto” option, a circuit is completed for R-W1 and R-Y on each heating “on” cycle, energizing reversing valve solenoid and pulling in compressor contactor starting compressor and outdoor motor. R-G also makes starting indoor blower motor. Heat pump heating cycle now in operation.

The second option has no “Auto” change over position, but instead energizes the reversing valve solenoid constantly whenever the system switch on subbase is placed in “Heat” position, the “B” terminal being constantly energized from R. A thermostat demand for heat completes R-Y circuit, pulling in compressor contactor starting compressor and outdoor motor. R-G also make starting indoor blower motor.

**High / Low Pressure Control** provides protection for the compressor. In the event the system pressures go above 350 PSI or below 15 PSI in either cooling or heating mode the compressor will be stopped. This will activate the right hand red light marked “System Service” on the front of the unit. The lockout circuit will hold compressor off line. When the system problem is corrected, the unit operation can be restored by turning the main power supply off and then back on, or reset the room thermostat. The low pressure control has a bypass to eliminate nuisance lockout on cold start up.

**Two Speed Outdoor Fan Motor** There is a thermostat located in the main electrical box that controls the switching between high and low speed. When in cooling mode and the outdoor ambient temperature is above 80 degrees, the outdoor motor will run on high speed; below 80 degrees, it will run on low speed. In heating mode the outdoor fan will always run in high speed.

**Door Interlock Switch** When the center cabinet panel (the one with the return air grille) is removed, the interlock switch will shut down the whole unit. When this panel is replaced, the unit will be able to start up. *NOTE: This panel must be removed before either of the remaining upper or lower panels can be removed.*

**Dirty Filter Switch** When the filters become dirty, the dirty filter switch will activate the center light marked “Filter Service” on the front of the cabinet. After the dirty filters have been replaced the dirty filter switch must be reset by turning the reset knob counter clockwise.

**Five Minute Compressor Time Delay** This delay is built into the electronic heat pump control. It provides short cycle protection for the compressor.

**Clogged Drain Switch** This switch is mounted in the bottom of the unit behind the lower electrical box with a probe extending above the unit base pan. In the advent the drains become clogged, this switch will shut down the unit before the water level in the unit base becomes high enough to allow water to enter the indoor side. This will activate the left hand red service light marked “Drain Service” on the front of the unit. When the clogged drain is corrected and the water level in the unit base pan is at an acceptable level, the unit will start up. The switch should be operated manually at least once a year to insure the float is free to rise in the event of high water level.

## OPTIONAL CLIMATE CONTROLS SEQUENCE OF OPERATION

The Climate Control **Option A** is an electronic, non-programmable manual or auto change over thermostat. The thermostat may be manually set to the heat or cool mode. The thermostat will maintain the temperature set on the thermostat in the mode in which it is set.

The Climate Control **Option B** is an electronic, non-programmable manual or auto change over thermostat and a four (4) hour timer. The thermostat may be manually set to the heat or cool mode. The thermostat will maintain the temperature set on the thermostat as long as the timer is on. When the set time expires, the unit will shut off and remain off until the timer is reset.

The Climate Control **Option C** is an electronic, non-programmable manual or auto change over thermostat and a six (6) hour timer. The thermostat may be manually set to the heat or cool mode. The thermostat will maintain the temperature set on the thermostat as long as the timer is on. When the set time expires, the unit will shut off and remain off until the timer is reset.

The Climate Control **Option D** is an electronic, programmable thermostat. The thermostat can be set in the heat, cool or automatic mode. When the thermostat is set in the heat mode, it can heat only to maintain the temperature set on the thermostat. When the thermostat is set in the cool mode, it can cool only to maintain the temperature set on the thermostat. When the thermostat is set in the automatic mode, the thermostat can change automatically to the heat or cool modes to maintain the temperature set on the thermostat.

## PRESSURE SERVICE PORTS

High and low pressure service ports are installed on all units so that the system operating pressures can be observed. Pressure charts can be found later in the manual covering all models on both cooling and heating cycles. It is imperative to match the correct pressure chart to the unit by model number. All service doors must be attached to obtain proper reading.



## DEFROST CYCLE

The defrost cycle is controlled by temperature and time on the solid state heat pump control.

When the outdoor temperature is in the lower 40°F temperature range or colder, the outdoor coil temperature is 32°F or below. This coil temperature is sensed by the coil sensor mounted near the bottom of the outdoor coil. Once coil temperature reaches 30°F or below, the coil sends a signal to the control logic of the heat pump control and the defrost timer will start.

After 30 minutes at 30°F or below, the heat pump control will place the system in the defrost mode.

During the defrost mode the refrigerant cycle switches back to the cooling cycle, the outdoor motor stops, electric heaters are energized, and hot gas passing through the outdoor coil melts any accumulated frost. When the temperature rises to approximately 57°F, the coil sensor will send a signal to the heat pump control which will return the system to heating operations automatically.

If some abnormal or temporary condition such as a high wind causes the heat pump to have a prolonged defrost cycle, the heat pump control will restore the system to heating operation automatically after 10 minutes.

There are three settings on the heat pump control – 30 minute, 60 minute and 90 minute. Models are shipped wired on the 30 minute setting for greatest operating economy. If special circumstances require a change to another time, remove wire connected to terminal 30 and reconnect to desired terminal. Refer to Figure 22. The manufacturer's recommendation is for 30 minute defrost cycles.

There is a cycle speed up jumper on the control. This can be used to reduce the time between defrost cycle operation without waiting for time to elapse.

There is an initial defrost jumper (sen jmp) on the control that can be used at any outdoor ambient during the heating cycle to simulate a 0° coil temperature. This can be used to check defrost operation of the unit without waiting for the outdoor ambient to fall into the defrost region.

FIGURE 22 – HEAT PUMP CONTROL BOARD

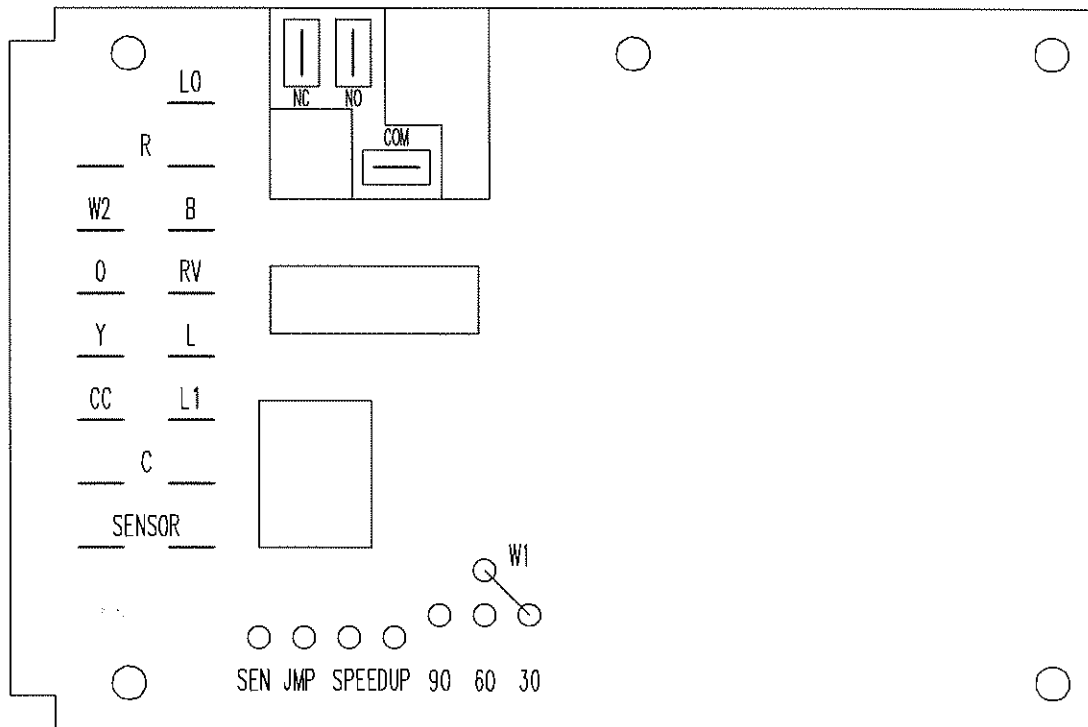

MIS-973

# Troubleshooting

## SOLID STATE HEAT PUMP CONTROL TROUBLESHOOTING PROCEDURE

1. Turn on AC power supply to indoor and outdoor units.
2. Turn thermostat blower switch to “fan on” – the indoor blower should start. (If it doesn’t, troubleshoot indoor unit and correct problem.)

3. Turn thermostat blower to “auto” position. Indoor blower should stop.
4. Set system switch to “heat” or “cool”. Adjust thermostat to call for heat or cool. The indoor blower, compressor and outdoor fan should start.

*NOTE: If there was no power to 24 volt transformer, the compressor and outdoor fan motor will not start for 5 minutes. This is because of the compressor short cycle protection.*

**TABLE 5 – TROUBLESHOOTING**

Sympton	Possible Cause	What to Check	How to Check or Repair
Compressor contactor does not energize (cooling or heating)	Control circuit wiring	Check for R connection at unit, and 24V between R-C.	Run R connection to outdoor unit to power heat pump control.
	Compressor lock out	1) Check for 24V between L1-C on heat pump control. 2) Check across high pressure switch.	1) If no voltage between L1-C turn thermostat off and on again to reset high pressure switch. 2) If high pressure switch is open and will not reset, replace high pressure switch.
	Compressor short cycle protection	Check for 24V between CC-C and Y-C on heat pump control.	If no voltage between CC-C jumper speed up terminal and within 10 seconds power should appear between CC-C. Remove speed up jumper after 10 seconds.
	Heat pump control defective	Check all other possible causes. Manual 2100-034	Replace heat pump control.
	Contactors defective	Check for open or shorted coil winding.	Replace contactor.
Fan outdoor motor does not run (cooling or heating except during defrost)	Motor defective	Check for open or shorted motor winding.	Replace motor.
	Motor capacitor defective	Check capacitor rating. Check for open or shorted capacitor.	Replace capacitor.
	Heat pump control defective	Check across fan relay on heat pump control (Com-NC)	Replace heat pump control.
Reversing valve does not energize (heating only)	Reversing valve solenoid coil defective	Check for open or shorted coil.	Replace solenoid coil.
	Heat pump control defective	Check for 24V between RV-C and B-C.	1) Check control circuit wiring. 2) Replace heat pump control
Unit will not go into defrost (heating only)	Temperature sensor or heat pump control defective	Disconnect temperature sensor from board, and jumper across speed up terminals and sen jmp terminals. This should cause the unit to go through a defrost cycle within one minute.	1) If unit goes through defrost cycle, replace temperature sensor. 2) If unit does not go through defrost cycle, replace heat pump control.
Unit will not come out of defrost (heating only)	Temperature sensor or heat pump control defective	Jumper across speed up terminals. This should cause the unit to come out of defrost within one minute.	1) If unit comes out of defrost cycle, replace temperature sensor. 2) If unit does not come out of defrost cycle, replace heat pump control.

## CHECKING TEMPERATURE SENSOR

1. Disconnect temperature sensor from board and from outdoor coil.
2. Use an ohmmeter and measure the resistance of the sensor. Also use ohmmeter to check for short or open.
3. Check resistance reading to chart of resistance use sensor ambient temperature. (Tolerance of part is  $\pm 10\%$ .)
4. If sensor resistance reads very low, then sensor is shorted and will not allow proper operation of the heat pump control.
5. If sensor is out of tolerance, shorted, open, or reads very low ohms then it should be replaced.

TABLE 6

TEMPERATURE ( F ) vs RESISTANCE ( R ) OF TEMPERATURE SENSOR									
F	R	F	R	F	R	F	R	F	R
-25.0	196871	5.0	72910	35.0	29986	65.0	13474	95.0	6531
-24.0	190099	6.0	76070	36.0	29157	66.0	13137	96.0	6383
-23.0	183585	7.0	68507	37.0	28355	67.0	12810	97.0	6239
-22.0	177318	8.0	66418	38.0	27577	68.0	12492	98.0	6098
-21.0	171289	9.0	64399	39.0	26823	69.0	12183	99.0	5961
-20.0	165487	10.0	62449	40.0	26092	70.0	11883	100.0	5827
-19.0	159904	11.0	60565	41.0	25383	71.0	11591	101.0	5697
-18.0	154529	12.0	58745	42.0	24696	72.0	11307	102.0	5570
-17.0	149355	13.0	56985	43.0	24030	73.0	11031	103.0	5446
-16.0	144374	14.0	55284	44.0	23384	74.0	10762	104.0	5326
-15.0	139576	15.0	53640	45.0	22758	75.0	10501	105.0	5208
-14.0	134956	16.0	52051	46.0	22150	76.0	10247	106.0	5094
-13.0	130506	17.0	50514	47.0	21561	77.0	10000	107.0	4982
-12.0	126219	18.0	49028	48.0	20989	78.0	9760	108.0	4873
-11.0	122089	19.0	47590	49.0	20435	79.0	9526	109.0	4767
-10.0	118108	20.0	46200	50.0	19896	80.0	9299	110.0	4663
-9.0	114272	21.0	44855	51.0	19374	81.0	9077	111.0	4562
-8.0	110575	22.0	43554	52.0	18867	82.0	8862	112.0	4464
-7.0	107010	23.0	42295	53.0	18375	83.0	8653	113.0	4367
-6.0	103574	24.0	41077	54.0	17898	84.0	8449	114.0	4274
-5.0	100260	25.0	39898	55.0	17434	85.0	8250	115.0	4182
-4.0	97064	26.0	38757	56.0	16984	86.0	8057	116.0	4093
-3.0	93981	27.0	37652	57.0	16547	87.0	7869	117.0	4006
-2.0	91008	28.0	36583	58.0	16122	88.0	7686	118.0	3921
-1.0	88139	29.0	35548	59.0	15710	89.0	7507	119.0	3838
0.0	85371	30.0	34545	60.0	15310	90.0	7334	120.0	3757
1.0	82699	31.0	33574	61.0	14921	91.0	7165	121.0	3678
2.0	80121	32.0	32634	62.0	14544	92.0	7000	122.0	3601
3.0	77632	33.0	31723	63.0	14177	93.0	6840	123.0	3526
4.0	75230	34.0	30840	64.0	13820	94.0	6683	124.0	3452

## FAN BLADE SETTING DIMENSIONS

Any service work requiring removal or adjustment in the fan and/or motor area will require that the dimensions in Table 7 be checked and blade adjusted in or out of the motor shaft accordingly.

FIGURE 23 – FAN BLADE SETTING

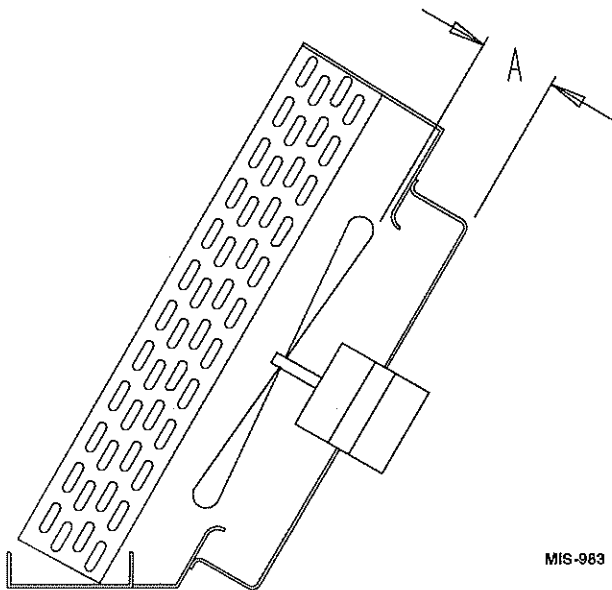

TABLE 7 – FAN BLADE DIMENSIONS

MODEL	DIMENSION A (INCHES)
QH241	.750
QH301	.750
QH361	.750
QH421	.750
QH481	.750

## REFRIGERANT CHARGE

The correct system R-22 charge is shown on the unit rating plate. Optimum unit cooling performance will occur with a refrigerant charge resulting in a Super Heat as shown in Table 8. If correct charge is in doubt, recover the refrigerant and recharge per the charge on the unit rating plate.

TABLE 8 – SUPER HEAT AT COMPRESSOR

MODEL	RATED CFM	95 F OD TEMPERATURE	82 F OD TEMPERATURE
QH241	800	16 - 18	14 - 16
QH301	1000	16 - 18	15 - 17
QH361	1200	16 - 18	14 - 16
QH421	1200	19 - 21	16 - 18
QH481	1200	23 - 25	22 - 24

TABLE 9 – INDOOR BLOWER PERFORMANCE

MODEL	RATED ESP	① MAX. ESP	② RATED CFM	③ OPTIONAL CFM	④ CONTINUOUS CFM	⑤ DEHUMIDIFICATION CFM	CFM @ MAX. ESP
QH241 ⑥	.10	0.5	800		800	500	700
QH301	.15	0.8	1000		1000	700	910
QH361	.15	0.8	1200	1000	1000	850	1175
QH421	.15	0.8	1200	1000	1000	850	1175
QH481	.15	0.8	1400	1100	1100	850	1175

**NOTE:** These units are equipped with a variable speed (ECM) indoor motor that automatically adjust itself to maintain approximately the same rate of indoor air flow in both heating and cooling, dry and wet coil conditions and at both 230/208 or 460 volts.

- ① Maximum ESP (inches WC) shown is with 1" thick disposable filter (reduced by .2 for 2" filter).
- ② **Rated CFM** for ducted applications – required for maximum performance rating. To obtain full CFM on models QH361 and QH421, connect the pink jumper wire (provided) to terminal #5 and #6 on the low voltage terminal block located in the circuit breaker box.
- ③ **Optional CFM** – the unit is shipped from the factory set to operate at the optional CFM level shown. This provides lower operating sound levels for non-ducted, free discharge applications. This reduces system capacity performance by approximately 2% at the same energy efficiency.
- ④ Continuous fan CFM is the total air being circulated during continuous fan mode.
- ⑤ Indoor air flow during periods of high humidity when system is operating under control of optional humidistat for maximum humidity reduction.
- ⑥ Models QH241 – when operating on 2nd stage heating the indoor air will increase to 1000 CFM.

## PRESSURE CHARTS

**TABLE 10 – COOLING PRESSURE – (All Temperatures in Degrees F)**

MODEL	RETURN AIR TEMP.	PRESSURE	AIR TEMPERATURE ENTERING OUTDOOR COIL								
			75 ①	80	85	90	95	100	105	110	115
QH241	75 DB	Low Side	73	73	74	76	77	79	80	81	83
	62 WB	High Side	195	199	214	229	244	259	274	289	304
	80 DB	Low Side	78	78	79	80	82	84	85	87	88
	67 WB	High Side	203	204	219	234	250	264	280	296	312
	85 DB	Low Side	84	84	85	86	88	89	91	93	94
	72 WB	High Side	121	213	228	244	259	274	290	305	320
QH301	75 DB	Low Side	75	75	76	77	78	79	80	81	82
	62 WB	High Side	226	202	242	258	273	319	303	319	335
	80 DB	Low Side	80	80	81	82	83	84	85	86	87
	67 WB	High Side	228	233	248	264	280	296	311	327	343
	85 DB	Low Side	86	86	87	88	89	90	91	92	93
	72 WB	High Side	238	240	257	273	290	306	323	339	356
QH361	75 DB	Low Side	74	74	75	76	77	78	79	80	81
	62 WB	High Side	212	215	233	251	269	287	305	323	341
	80 DB	Low Side	79	79	80	81	82	83	84	85	86
	67 WB	High Side	219	220	239	257	276	294	312	331	350
	85 DB	Low Side	85	85	86	87	88	89	90	91	92
	72 WB	High Side	223	228	247	267	286	305	324	343	363
QH421	75 DB	Low Side	71	71	72	73	74	75	76	77	79
	62 WB	High Side	246	248	264	281	299	318	339	362	385
	80 DB	Low Side	75	76	77	78	79	80	81	82	83
	67 WB	High Side	251	243	270	288	307	327	349	371	395
	85 DB	Low Side	82	82	83	84	85	86	87	88	90
	72 WB	High Side	261	262	279	298	318	330	361	384	409
QH481	75 DB	Low Side	69	71	72	72	73	74	75	75	76
	62 WB	High Side	221	237	252	270	287	305	323	343	363
	80 DB	Low Side	75	76	76	77	78	79	80	80	81
	67 WB	High Side	228	244	260	276	294	312	331	351	372
	85 DB	Low Side	81	82	82	83	84	85	86	86	87
	72 WB	High Side	237	252	269	285	304	323	342	363	385

Low side pressure  $\pm$  2 psig

High side pressure  $\pm$  5 psig

Tables are based upon rated CFM (airflow) across the evaporator coil. If there is any doubt as to correct operating charge being in the system, the charge should be removed, system evacuated and recharged to serial plate instructions.

① 75° F outdoor temperature condenser fan motor is running on low speed.

**TABLE 11 – HEATING PRESSURE – (All Temperatures in Degrees F)**

MODEL	RETURN AIR TEMP.	PRESSURE	AIR TEMPERATURE ENTERING OUTDOOR COIL													
			0	5	10	15	17	20	25	30	35	40	47	50	55	60
QH241	70	Low Side	7	12	17	23	25	28	33	39	44	50	57	60	65	71
		High Side	147	155	164	172	176	181	189	198	206	215	227	232	240	249
QH301	70	Low Side	16	20	24	28	30	33	37	41	45	49	55	58	62	67
		High Side	157	163	169	175	177	180	187	193	199	205	213	217	222	228
QH361	70	Low Side	13	17	21	25	27	30	34	38	42	46	52	55	59	63
		High Side	147	153	159	164	167	171	176	182	188	194	202	206	211	217
QH421	70	Low Side	13	18	22	26	28	31	35	39	44	48	54	57	61	65
		High Side	161	168	174	180	183	187	193	199	206	212	221	225	231	237

**OPTIONAL ACCESSORIES**

MODEL	DESCRIPTION
QLG-10	Outdoor louver grille, clear anodized aluminum for 2, 2-1/2, 3, 3-1/2 Ton QTEC Models
QLG-15	Outdoor louver grille, clear anodized aluminum for 4 Ton QTEC Models
QLG-20	Outdoor louver grille, medium bronze anodized aluminum for 2, 2-1/2, 3, 3-1/2 Ton QTEC Models
QLG-25	Outdoor louver grille, medium bronze anodized aluminum for 4 Ton QTEC Models
QLG-30	Outdoor louver grille, dark bronze anodized aluminum for 2, 2-1/2, 3, 3-1/2 Ton QTEC Models
QLG-35	Outdoor louver grille, dark bronze anodized aluminum for 4 Ton QTEC Models
QWS42	14 Inch wall sleeve for 2, 2-1/2, 3, 3-1/2 Ton QTEC Models. <i>Required for all units.</i>
QWS48	14 Inch wall sleeve for 4 Ton QTEC Models. <i>Required for all units.</i>
QSTX42	Side trim piece extension for 2, 2-1/2, 3, 3-1/2 Ton QTEC Models. Provides cabinet extension between interior wall and unit when wall thickness is between 5 inches and 12 inches.
QPB42	Free blow plenum box for 2, 2-1/2, 3, 3-1/2 Ton QTEC Models. Includes front supply grilles.
QPB48	Free blow plenum box for 4 Ton QTEC Models. Includes front supply grilles.
QCX-10	Cabinet extension for ducted applications on 2, 2-1/2, 3, 3-1/2 Ton QTEC Models. Height will be 20 inches high.
QCX-15	Cabinet extension for ducted applications on 4 Ton QTEC Models. Height will be 20 inches high.



**COMPONENT CODE**

- CB1 CIRCUIT BREAKER #1
- CC COMPRESSOR CONTACTOR
- CCP CAP COMPRESSOR
- CCM CAP MOTOR
- CCF CAP FAN CONTACTOR
- CCG CAP GEAR CONTACTOR
- CCS CAP START CONTACTOR
- CCV CAP VALVE CONTACTOR
- CCW CAP WATER CONTACTOR
- CCX CAP EXHAUST CONTACTOR
- CCY CAP YIELD CONTACTOR
- CCZ CAP ZONE CONTACTOR
- CC1 CAP #1
- CC2 CAP #2
- CC3 CAP #3
- CC4 CAP #4
- CC5 CAP #5
- CC6 CAP #6
- CC7 CAP #7
- CC8 CAP #8
- CC9 CAP #9
- CC0 CAP #0
- CC10 CAP #10
- CC11 CAP #11
- CC12 CAP #12
- CC13 CAP #13
- CC14 CAP #14
- CC15 CAP #15
- CC16 CAP #16
- CC17 CAP #17
- CC18 CAP #18
- CC19 CAP #19
- CC20 CAP #20
- CC21 CAP #21
- CC22 CAP #22
- CC23 CAP #23
- CC24 CAP #24
- CC25 CAP #25
- CC26 CAP #26
- CC27 CAP #27
- CC28 CAP #28
- CC29 CAP #29
- CC30 CAP #30
- CC31 CAP #31
- CC32 CAP #32
- CC33 CAP #33
- CC34 CAP #34
- CC35 CAP #35
- CC36 CAP #36
- CC37 CAP #37
- CC38 CAP #38
- CC39 CAP #39
- CC40 CAP #40
- CC41 CAP #41
- CC42 CAP #42
- CC43 CAP #43
- CC44 CAP #44
- CC45 CAP #45
- CC46 CAP #46
- CC47 CAP #47
- CC48 CAP #48
- CC49 CAP #49
- CC50 CAP #50
- CC51 CAP #51
- CC52 CAP #52
- CC53 CAP #53
- CC54 CAP #54
- CC55 CAP #55
- CC56 CAP #56
- CC57 CAP #57
- CC58 CAP #58
- CC59 CAP #59
- CC60 CAP #60
- CC61 CAP #61
- CC62 CAP #62
- CC63 CAP #63
- CC64 CAP #64
- CC65 CAP #65
- CC66 CAP #66
- CC67 CAP #67
- CC68 CAP #68
- CC69 CAP #69
- CC70 CAP #70
- CC71 CAP #71
- CC72 CAP #72
- CC73 CAP #73
- CC74 CAP #74
- CC75 CAP #75
- CC76 CAP #76
- CC77 CAP #77
- CC78 CAP #78
- CC79 CAP #79
- CC80 CAP #80
- CC81 CAP #81
- CC82 CAP #82
- CC83 CAP #83
- CC84 CAP #84
- CC85 CAP #85
- CC86 CAP #86
- CC87 CAP #87
- CC88 CAP #88
- CC89 CAP #89
- CC90 CAP #90
- CC91 CAP #91
- CC92 CAP #92
- CC93 CAP #93
- CC94 CAP #94
- CC95 CAP #95
- CC96 CAP #96
- CC97 CAP #97
- CC98 CAP #98
- CC99 CAP #99
- CC00 CAP #00

USE COPPER CONDUCTORS ONLY  
SUITABLE FOR AT LEAST 75°C

- A** LABELLED WIRES CORRECT IF NO OPTIONS USED.
- B** WIRE RED WIRE TO 200 Y
- C** WIRE RED WIRE TO 200 Y DESIGN
- D** WIRE RED WIRE TO 200 Y DESIGN
- E** WIRE RED WIRE TO 200 Y DESIGN

FACTORY STD.	FIELD	OPTIONAL
HIGH VOLTAGE		
LOW VOLTAGE		
ACCESSORY		

BK - BLACK	G - GREEN	T - TAN
BR - BROWN	BL - BLUE	RK - PINK
P - RED	PR - PURPLE	L - LAVENDER
O - ORANGE	GY - GREY	
Y - YELLOW	W - WHITE	

4100-102 D

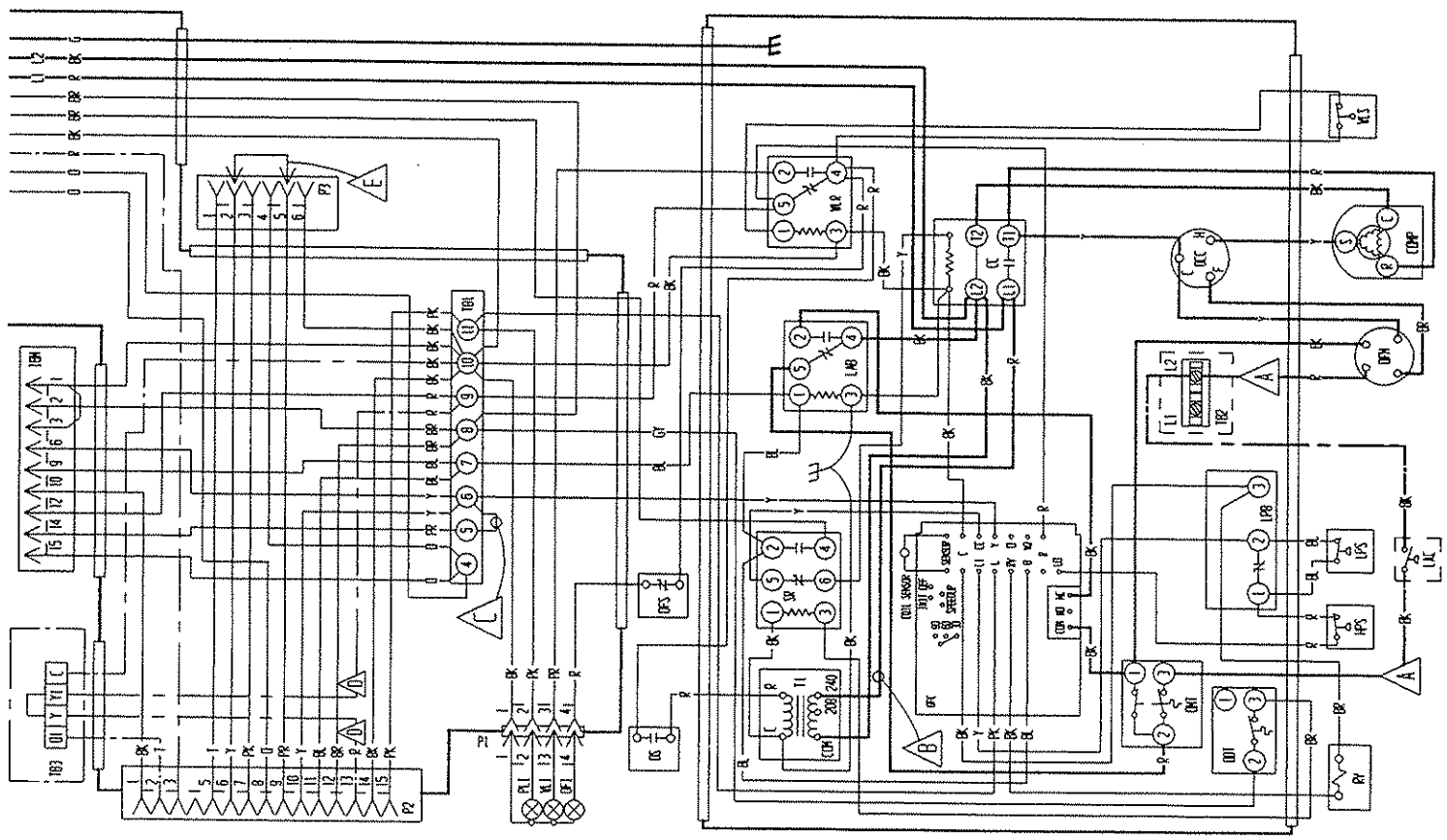
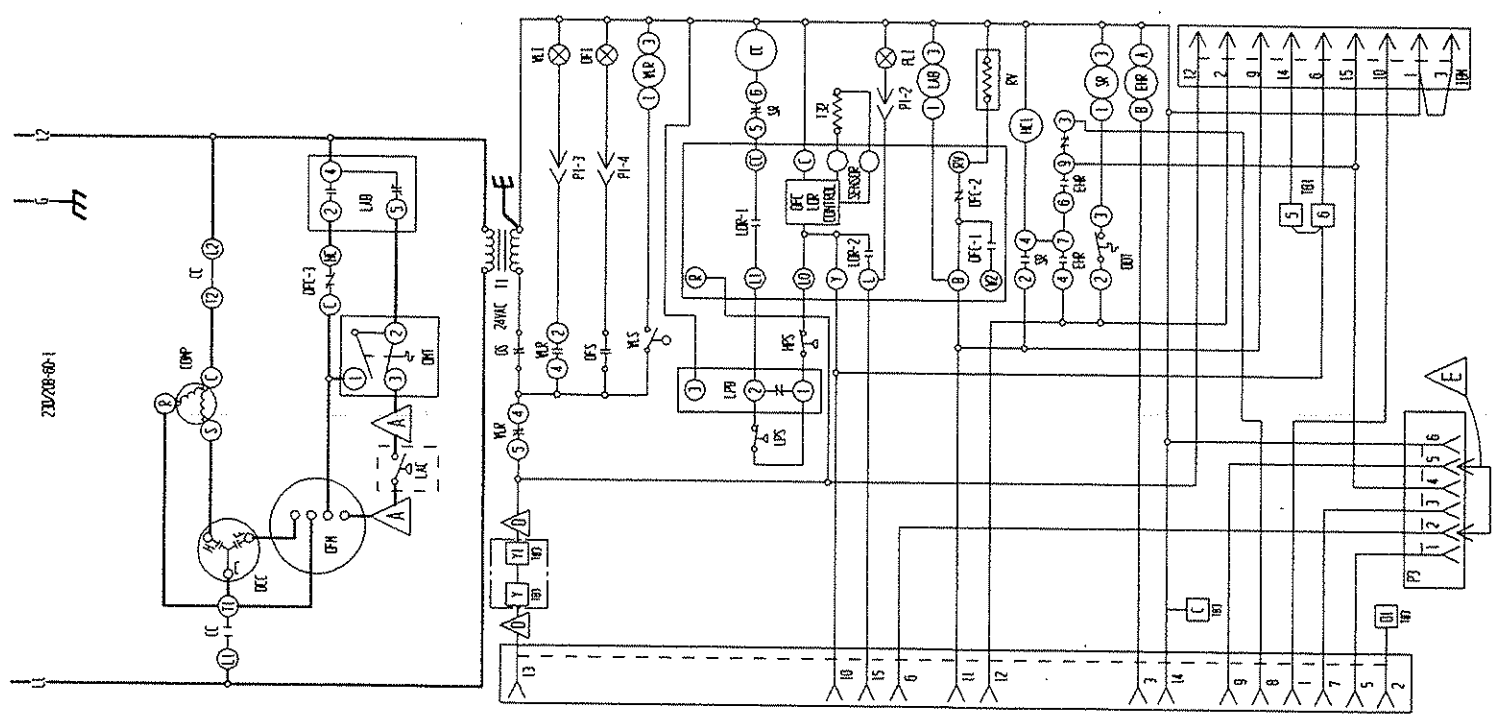



**COMPONENT CODE**

- BA CIRCUIT BREAKER A1
- BB CIRCUIT BREAKER P2
- CC COMPRESSOR CONTACTOR
- DD COMPRESSOR
- EE PRESSUR CONTROL
- FF DIRTY FILTER INDICATOR
- GG DIRTY FILTER SWITCH
- HH COOL WATER
- II EXHAUST HEAT RELAY
- JJ GRAZING
- KK HEATER CONTACTOR A1
- LL HEATER CONTACTOR P2
- MM HIGH PRESSURE SWITCH
- NN HEAT STRIP A1
- OO HEAT STRIP P2
- PP INDOOR BLOWER MOTOR
- QQ LOW AMBIGHT BRASS
- RR LOW AMBIGHT CONTROL
- SS LOW PRESSURE BRASS
- TT LOW PRESSURE SWITCH
- UU LIMIT SWITCH
- VV OUTDOOR FAN CAPACTOR
- WW OUTDOOR FAN MOTOR
- XX OUTDOOR MOTOR REVERSANT
- YY ACCESSORY PUG A2
- ZZ ACCESSORY PUG P2
- AA1 PRESSURE LOCKOUT INDICATOR
- AA2 REV. VALVE SH INDIC
- BB1 TRANSFORMER
- BB2 TERMINAL BLOCK A1
- BB3 TERMINAL BLOCK P2
- CC1 HIGH WATER LEVEL INDICATOR
- CC2 WATER LEVEL RELAY
- CC3 WATER LEVEL SWITCH

USE COPPER CONDUITS ONLY  
 SUITABLE FOR AT LEAST 75°C

A D F  
 LAGGED WIRES CONTACT  
 IF NO OPTIONS USED.

B  
 WIRE RED WIRE TO 200 V  
 TAP FOR 200 V OPERATION

C  
 INSTALL JUMPER FOR HIGH SPEED  
 BLOWER OPERATION ON MODELS 35 & 42

E  
 IF VENT OPTION IS INSTALLED, PUG  
 WITH JUMPER 2 TO 5 IS REQUIRED &  
 PUG FROM VENT OPTION INSTALLED

FACTORY STD.	FIELD	OPTIONAL
HIGH VOLTAGE		
LOW VOLTAGE		
ACCESSORY		

BK - BLACK	G - GREEN	I - TAN
BH - BROWN	B - BLUE	PK - PINK
R - RED	PR - PURPLE	L - LARKER
D - DRAB	DT - GREY	
Y - YELLOW	W - WHITE	

4100-201 C

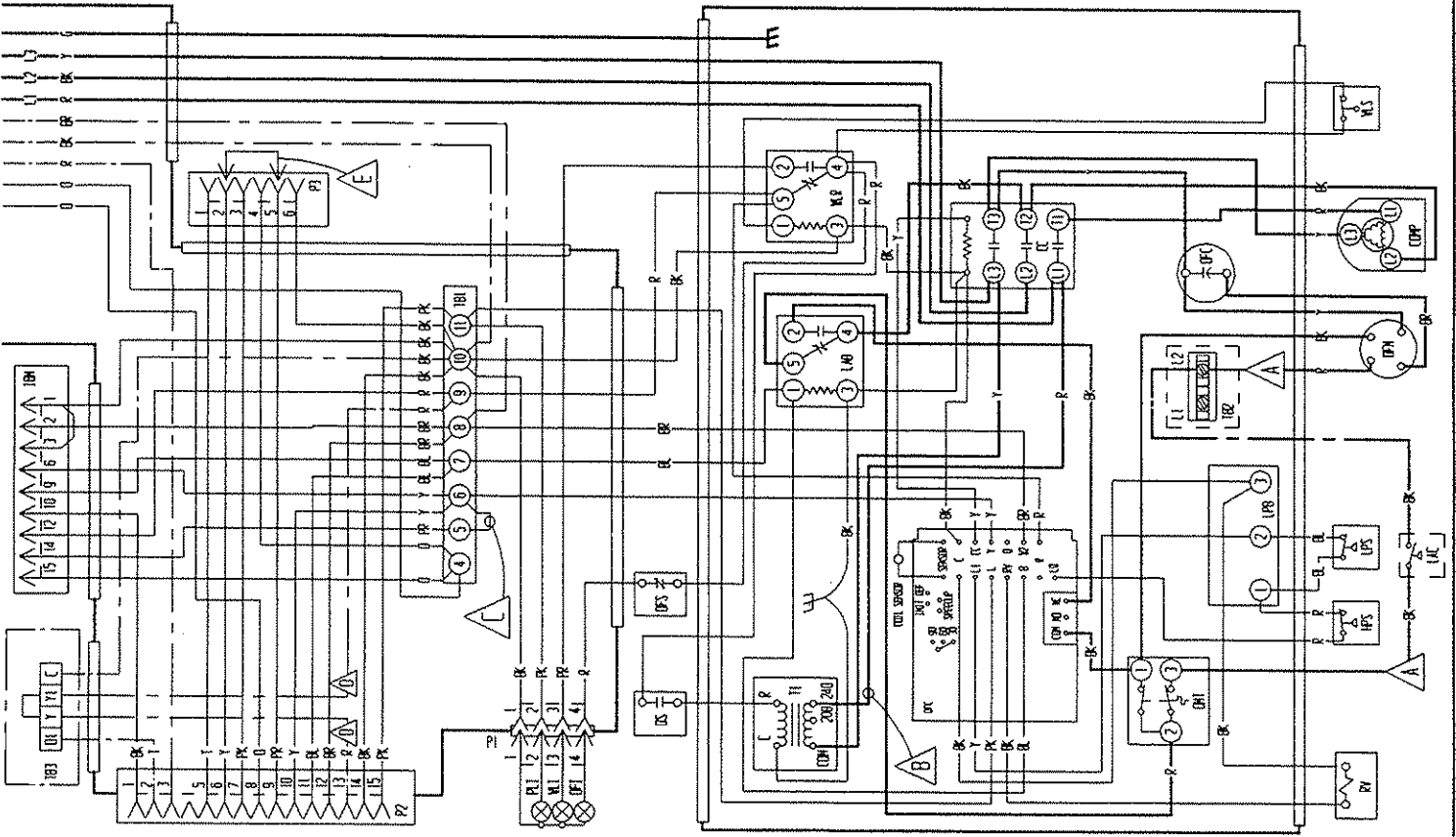
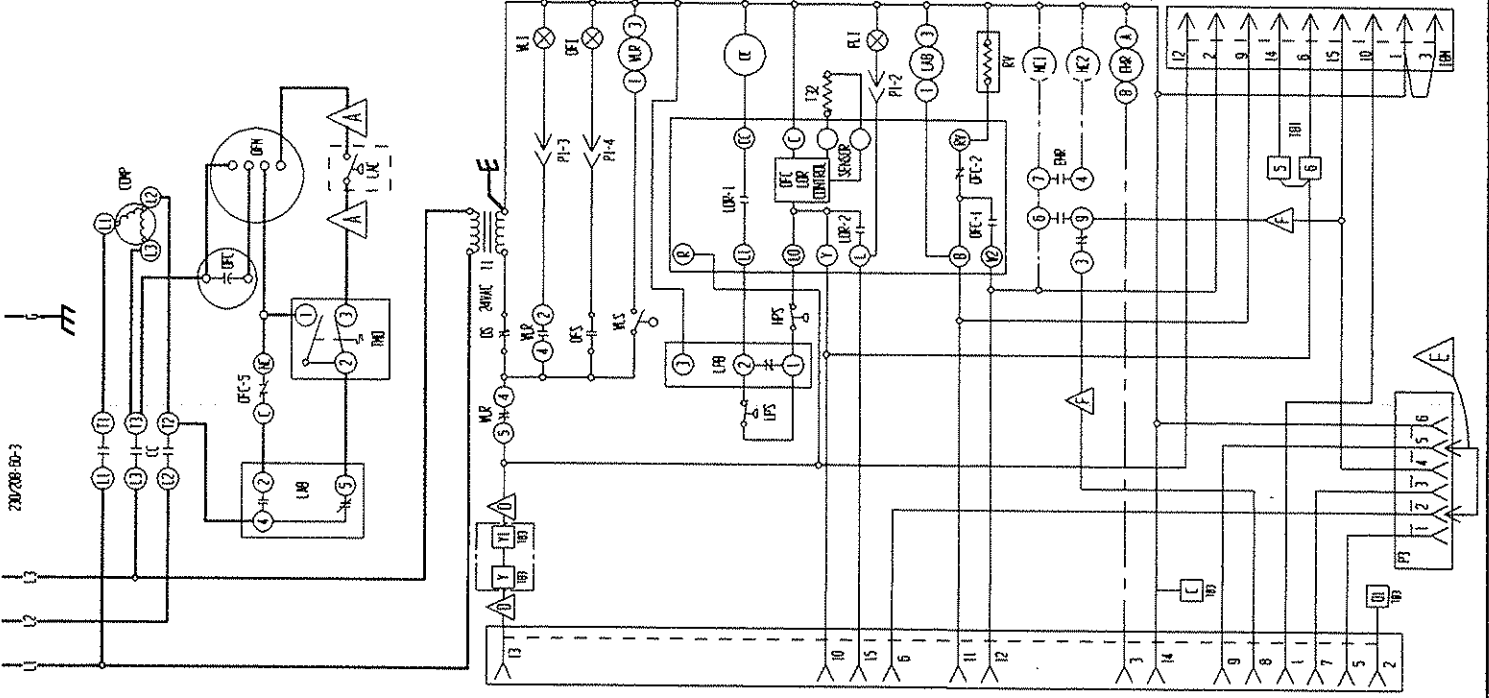

COMPONENT CODE

- BH CIRCUIT BREAKER #1
- CC COMPRESSOR CONTACTOR
- CCP COMPRESSOR
- DFC DEFROST CONTROL
- DF1 DIRTY FILTER INDICATOR
- DF5 DIRTY FILTER SWITCH
- DS DRAIN SWITCH
- DRK EMERGENCY HEAT RELAY
- DRO GROUND
- HCL HEATER CONTACTOR #1
- HPS HIGH PRESSURE SWITCH
- HST HEAT STRIP #1
- HV HEATER BLUVER MOTOR
- LAC LOW AMBIEHT CONTROL
- LPB LOW PRESSURE BRASS
- LPS LOW PRESSURE SWITCH
- LS LIMIT SWITCH
- OUT OUTDOOR THERMISTAT
- DFC OUTDOOR FAN CONTACTOR
- DF4 OUTDOOR FAN MOTOR
- DWT OUTDOOR WIND THERMISTAT
- P1 ACCESSORY PLUG #1
- P2 ACCESSORY PLUG #2
- P3 ACCESSORY PLUG #3
- PLV PRESSURE LOCKOUT SWITCH
- RY RY VALVE SOLENOID
- SR START STOP RELAY
- TI THERMISTOR
- TB1 TERMINAL BLOCK #1
- TB2 TERMINAL BLOCK #2
- TB3 TERMINAL BLOCK #3
- ML HIGH WATER LEVEL INDICATOR
- MR WATER LEVEL RELAY
- MS WATER LEVEL SWITCH

USE COPPER CONDUCTORS ONLY  
SUITABLE FOR AT LEAST 75°C

▲ Labeled wires connect if no options used.

▲ Mide pin wire to 208 Y tap for 208 Y operation

▲ Install jumper for high speed block operation on models 25 & 42

▲ If vent option is installed, plug wire jumper 2 to 5 is removed & plug from vent option inserted

FACTORY FIELD OPTIONAL

HIGH VOLTAGE	LOW VOLTAGE	ACCESSORY
BK - BLACK	G - GREEN	L - TAN
BN - BROWN	R - BLUE	PK - PINK
B - RED	PR - PURPLE	L - LAMPRED
O - ORANGE	GY - GREY	
Y - YELLOW	W - WHITE	

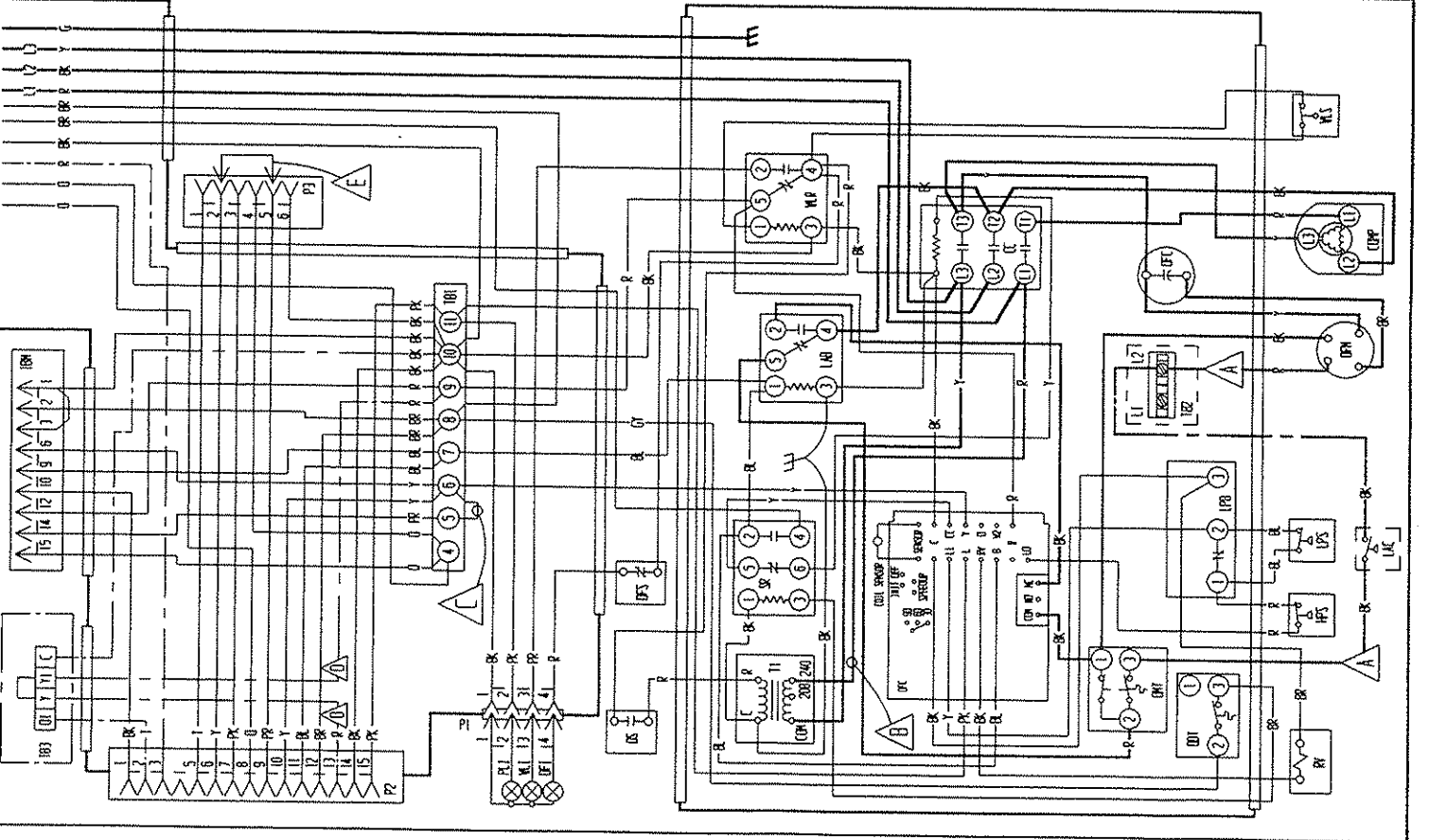
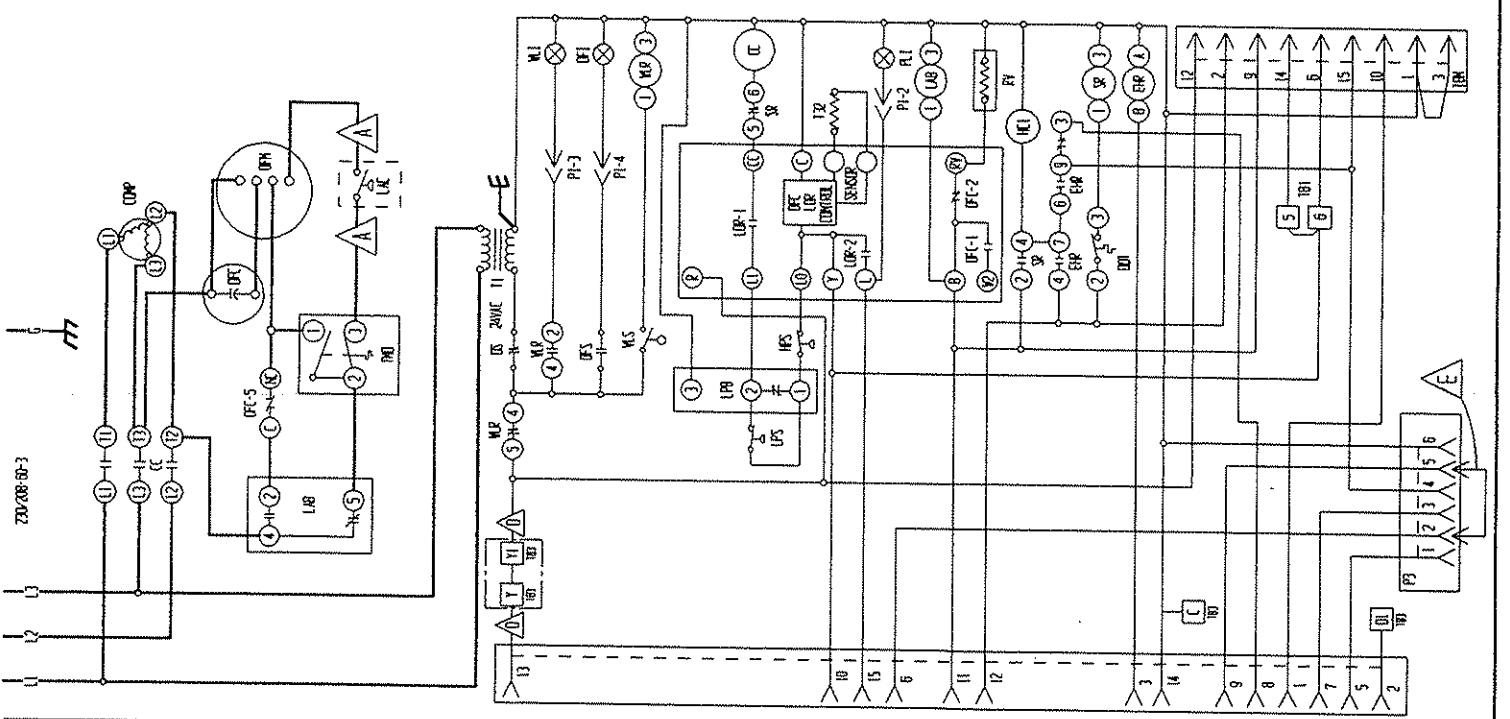

4100-202 0

**COMPONENT CODE**

- BR CIRCUIT BREAKER #1
- CR2 CIRCUIT BREAKER #2
- CC COMPRESSOR CONTACTOR
- CCP COMPRESSOR
- DFC DEFROST CONTROL
- DFI DRY FILTER INDICATOR
- DS DRY FILTER SWITCH
- DS COOP SWITCH
- DS EMERGENCY HEAT RELAY
- F FUSE CLASS (SEE DE CEN)
- GO (OPTION)
- M1 HEATER CONTACTOR #1
- M2 HEATER CONTACTOR #2
- PS HIGH PRESSURE SWITCH
- AS1 HEAT STRIP #1
- AS2 HEAT STRIP #2
- UBA INDOOR BLOWER MOTOR
- UBB LOW AMBIENT BYPASS
- UBC LOW AMBIENT CONTROL
- UBD LOW PRESSURE BYPASS
- UBE LOW PRESSURE SWITCH
- UBF LIMIT SWITCH
- UBG OUTDOOR FAN CONTACTOR
- UBH OUTDOOR FAN MOTOR
- UBI OUTDOOR MOTOR REVERSAL
- PI ACCESSORY PLUG #1
- P2 ACCESSORY PLUG #2
- P3 ACCESSORY PLUG #3
- RV REVERSE VALVE SOLINOID
- T1 TRANSFORMER #1
- T2 TRANSFORMER #2
- TR1 TERMINAL BLOCK #1
- TR2 TERMINAL BLOCK #2
- TR3 TERMINAL BLOCK #3
- TR4 TERMINAL BLOCK #4
- DR OUTDOOR MOTOR RELAY
- M1 HIGH WATER LEVEL INDICATOR
- MR WATER LEVEL RELAY
- MS WATER LEVEL SWITCH

USE COPPER CONDUCTORS ONLY  
SUITABLE FOR AT LEAST 75°C

- A** LABELLED WIRES CONNECT IF NO OPTIONS USED.
- B** WIRE PER WIRE TO 208 V
- C** TAP FOR 208 V OPERATION
- E** INSTALL JUMPER FOR HIGH SPEED BLOWER OPERATION ON MODELS 76 & 42 IF VEH1 OPTION IS INSTALLED. R.L.C. WITH JUMPER 2 TO 5 IS PROVIDED & PLUG FROM VEH1 OPTION ACCEPTED

FACTORY STD.	FIELD	OPTIONAL
HIGH VOLTAGE		
LOW VOLTAGE		
ACCESSORY		

BK - BLACK	G - GREEN	L - LAM
BR - BROWN	B - BLUE	PK - PINK
P - RED	PR - PURPLE	L - LAMP
D - DRAB	DT - DUST	
Y - YELLOW	W - WHITE	

4100-301 E

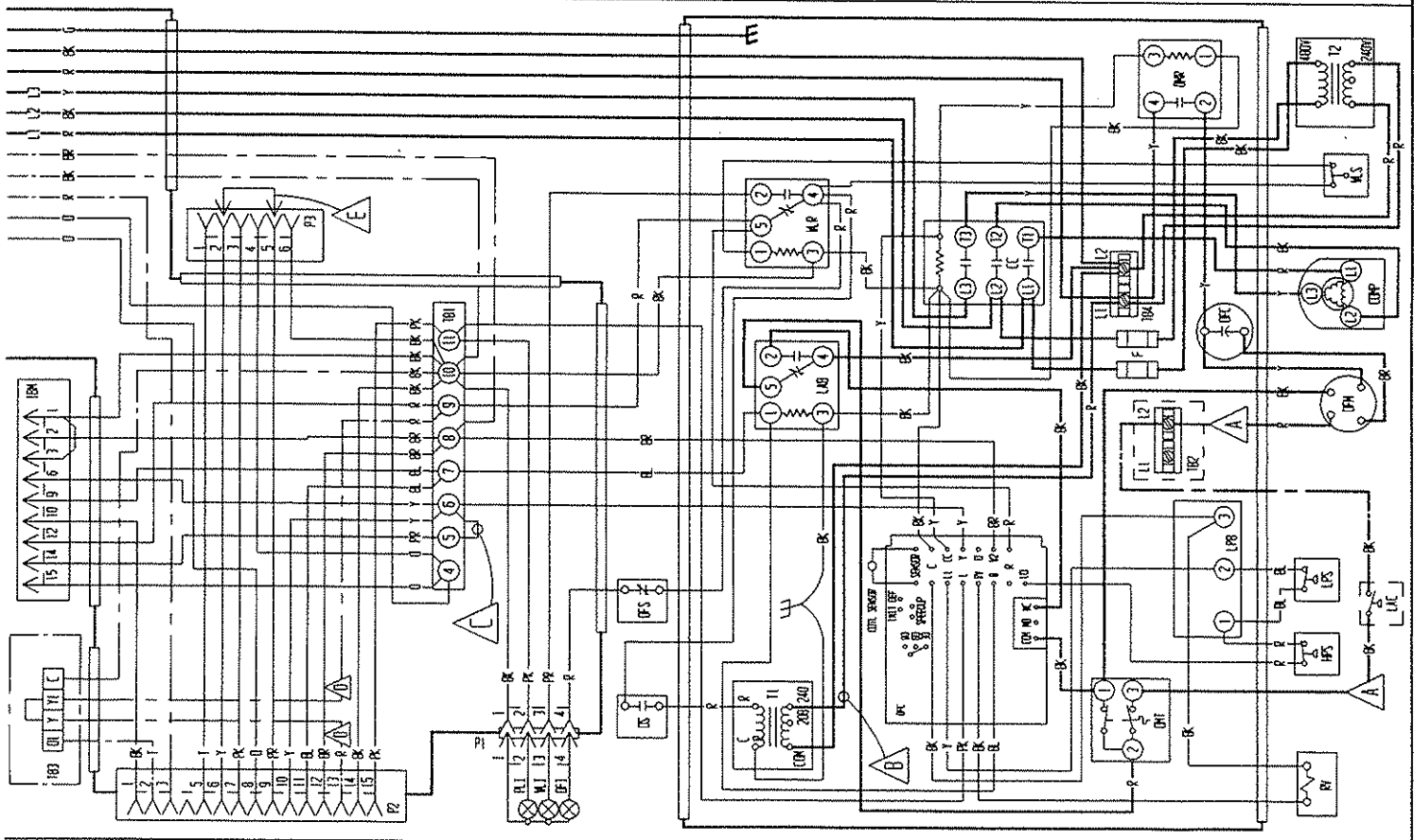
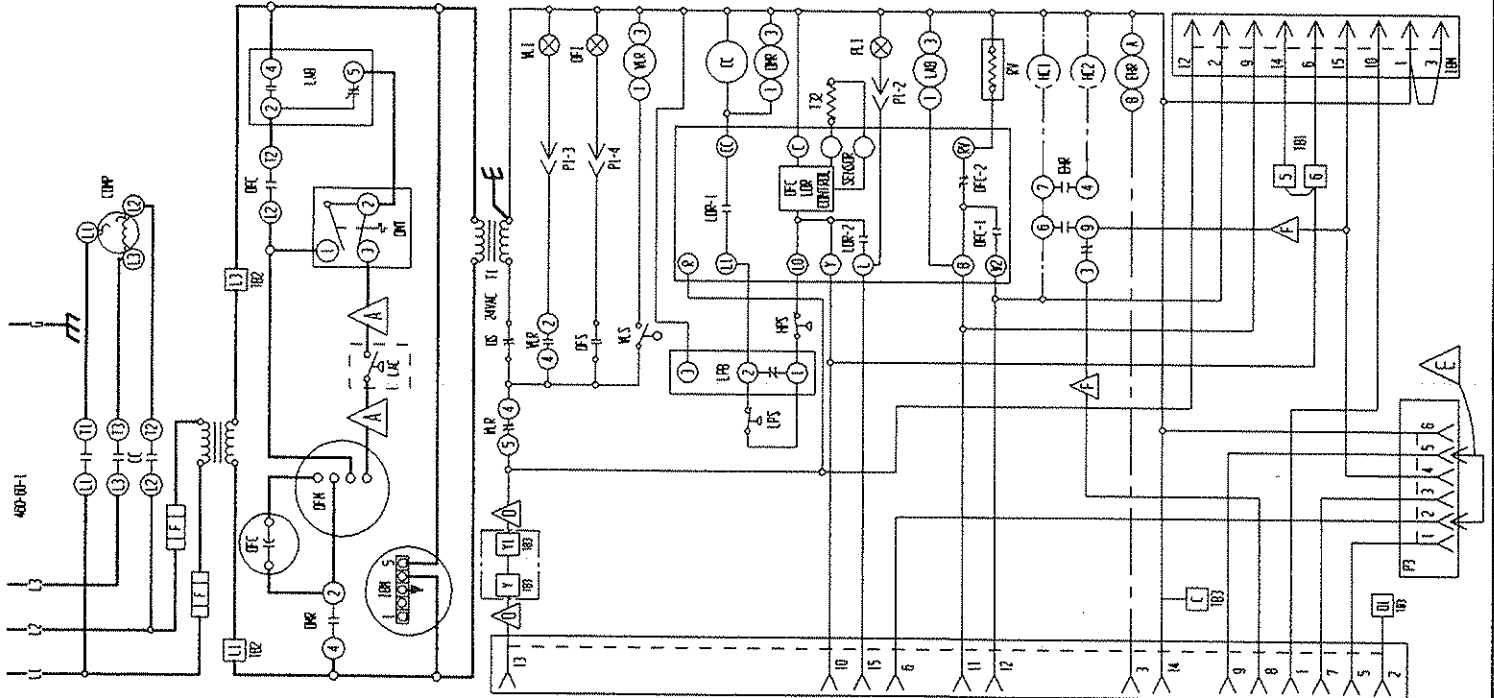

**COMPONENT CODE**

- CC COMPRESSOR CONTACTOR
- CCP COMPRESSOR
- CCF COMPRESSOR CONTACTOR
- CCU CAPACITY FILTER INDICATOR
- CCV CAPACITY FILTER SWITCH
- CCW CAPACITY SWITCH
- CCX CAPACITY SWITCH
- CCZ CAPACITY SWITCH
- CC1 CAPACITY SWITCH
- CC2 CAPACITY SWITCH
- CC3 CAPACITY SWITCH
- CC4 CAPACITY SWITCH
- CC5 CAPACITY SWITCH
- CC6 CAPACITY SWITCH
- CC7 CAPACITY SWITCH
- CC8 CAPACITY SWITCH
- CC9 CAPACITY SWITCH
- CC10 CAPACITY SWITCH
- CC11 CAPACITY SWITCH
- CC12 CAPACITY SWITCH
- CC13 CAPACITY SWITCH
- CC14 CAPACITY SWITCH
- CC15 CAPACITY SWITCH
- CC16 CAPACITY SWITCH
- CC17 CAPACITY SWITCH
- CC18 CAPACITY SWITCH
- CC19 CAPACITY SWITCH
- CC20 CAPACITY SWITCH
- CC21 CAPACITY SWITCH
- CC22 CAPACITY SWITCH
- CC23 CAPACITY SWITCH
- CC24 CAPACITY SWITCH
- CC25 CAPACITY SWITCH
- CC26 CAPACITY SWITCH
- CC27 CAPACITY SWITCH
- CC28 CAPACITY SWITCH
- CC29 CAPACITY SWITCH
- CC30 CAPACITY SWITCH
- CC31 CAPACITY SWITCH
- CC32 CAPACITY SWITCH
- CC33 CAPACITY SWITCH
- CC34 CAPACITY SWITCH
- CC35 CAPACITY SWITCH
- CC36 CAPACITY SWITCH
- CC37 CAPACITY SWITCH
- CC38 CAPACITY SWITCH
- CC39 CAPACITY SWITCH
- CC40 CAPACITY SWITCH
- CC41 CAPACITY SWITCH
- CC42 CAPACITY SWITCH
- CC43 CAPACITY SWITCH
- CC44 CAPACITY SWITCH
- CC45 CAPACITY SWITCH
- CC46 CAPACITY SWITCH
- CC47 CAPACITY SWITCH
- CC48 CAPACITY SWITCH
- CC49 CAPACITY SWITCH
- CC50 CAPACITY SWITCH

USE COPPER CONDUCTORS ONLY  
SUITABLE FOR AT LEAST 75°C

A
D
B
C
E

LABELED WIRES CONNECT  
IF NO OPTIONS USED.

MAKE RED WIRE TO 230 V  
TAP FOR 230 V OPERATION

INSTALL JUMPER FOR HIGH SPEED  
BLOWER OPERATION ON MODELS 31 A & Q  
BY NEXT OPTION IS INSTALLED, FLAG  
WITH JUMPER 2 TO 5 IS BARRING &  
FLUO FROM NEXT OPTION ASSEMBLED

FACTORY FIELD OPTIONAL

HIGH VOLTAGE			
LOW VOLTAGE			
ACCESSORY			

CK - BLACK	G - GREEN	T - TAN
BN - BROWN	R - BLUE	PK - PINK
BL - BLUE	RR - RED	L - LAMP/RED
W - WHITE	Y - YELLOW	OP - OIL
		V - VOLTAGE

4100-302 G

