



# OPERATION INSTRUCTIONS

---

**MODEL: QERV-A4A**

**ENERGY RECOVERY VENTILATOR  
WITH EXHAUST**

**FOR USE WITH BARD  
2 THRU 3-1/2 TON  
QH SERIES HEAT PUMPS**

---

**BARD MANUFACTURING COMPANY  
Bryan, Ohio 43506**

*Since 1914...Moving ahead, just as planned.*

Manual:	2100-293
Supersedes:	
File:	Volume II, Tab 14
Date:	February 14, 1997

# Contents

---

QERV Model Nomenclature .....	1
Electrical Specifications .....	1
General Description of QERV .....	1
Control Requirements .....	1
Recommended Control Sequences .....	1
Ventilation Air Flow .....	2
Performance and Application Data .....	3
Maintenance Procedures – Monthly .....	4
Maintenance Procedures – Semi Annually .....	4

## Figures

Figure 1 .....	5
----------------	---

## Tables

Table 1 .....	2
---------------	---

## Model Nomenclature

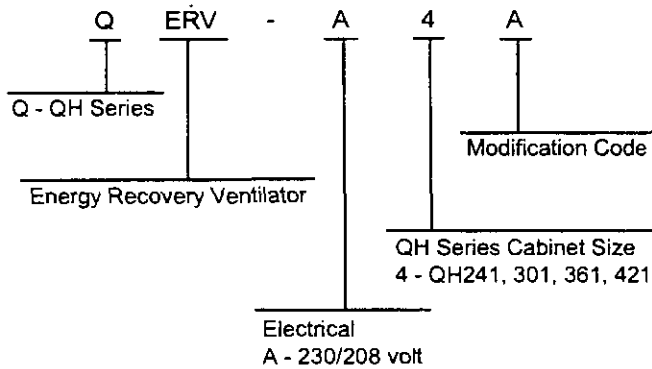

Model	For Use With Following Units	Electrical
QERV-A4A	QH241-A, B	230/208 - 1 or 3 Phase
	QH301-A, B	
	QH361-A, B	
	QH421-A, B	
	QH241-C	460 - 3 Phase
	QH301-C	
	QH361-C	
QH421-C		

## ELECTRICAL SPECIFICATIONS

Model	Voltage	Amps	Control Voltage
QERV-A4A	230/208	2.2	24V

## GENERAL DESCRIPTION

The Energy Recovery Ventilator was designed to provide energy efficient, cost effective ventilation to meet I. A. Q. (Indoor Air Quality) requirements while still maintaining good indoor comfort and humidity control for a variety of applications such as schools, classrooms, lounges, conference rooms, beauty salons and others. It provides a constant supply of fresh air for control of airborne pollutants including CO<sub>2</sub>, smoke radon, formaldehyde, excess moisture, virus and bacteria.

The ventilator incorporates patented rotary heat exchange state-of-the-art technology to remove both heat and moisture.

It is designed as a single package which is factory installed. The package consists of a unique rotary Energy Recovery Cassette that can be easily removed for cleaning or maintenance. It has two 15 inch diameter heat transfer wheels for efficient heat transfer. The heat transfer wheels use a permanently bonded dry desiccant coating for total heat recovery.

Ventilation is accomplished with 2 blower/motor assemblies each consisting of a drive motor and dual blowers for maximum ventilation at low sound levels. Air is exhausted at the same rate that fresh air is brought into the structure thus not pressuring the building. The rotating energy wheels provide the heat transfer effectively during both summer and winter conditions. Provides required ventilation to meet the requirements of ASHRAE 62-1989 standard.

**NOTE:** Operation is not recommended below 5 degrees F outdoor temperature because freezing of moisture in the heat transfer wheel can occur.

## CONTROL REQUIREMENTS

- Indoor blower motor must be run when ever the QERV is run.
- Select the correct motor speed on the QERV. Using Table 1 of the QERV Installation Instructions determine the motor speed needed to get the desired amount of ventilation air needed. For instance, do not use the high speed tap on a QERV-A4A if only 200 CFM of ventilation air is needed. Use the low speed tap. Using the high speed tap would serve no useful purpose and would effect the overall efficiency of the air conditioning system. System operation costs would also increase.
- Run the QERV only during periods when the conditioned space is occupied. Running the QERV during unoccupied periods wastes energy, decreases the expected life of the QERV, and can result in a large moisture buildup in the structure. The QERV removes 60 to 70% of the moisture in the incoming air, not 100% of it. Running the QERV when the structure is unoccupied allows moisture to build up in the structure because there is little or no cooling load. Thus, the air conditioner is not running enough to remove the excess moisture being brought in. Use a control system that in some way can control the system based on occupancy.



## IMPORTANT

Operating the QERV during unoccupied periods can result in a build up of moisture in the classroom.

## RECOMMENDED CONTROL SEQUENCES

Several possible control scenarios are listed below:

- Use a programmable electronic thermostat with auxiliary terminal to control the QERV based on daily programmed occupancy periods. Bard markets and recommends the the White-Rodgers 1F94-80 (Bard Part No. 8403-034), programmable electronic thermostat for heat pump applications.

2. Use a motion sensor in conjunction with a mechanical thermostat to determine occupancy in the classroom. Bard markets the CS2000 for this use.
3. Use a DDC control system to control the QERV based on a room occupancy schedule to control the QERV.
4. Tie the operation of the QERV into the light switch. The lights in a room are usually on only when occupied.
5. Use a manual timer that the occupants turn to energize the QERV for a specific number of hours.
6. Use a programmable mechanical timer to energize the QERV and indoor blower during occupied periods of the day.

## VENTILATION AIR FLOW

The QERV-A4A is equipped with a 3 speed motor to provide the capability of adjusting the ventilation rates to the requirements of the specific application by simply changing motor speeds.

**TABLE 1**

VENTILATION AIR (CFM)			
	High Speed (Black)	Medium Speed (Blue)	Low Speed (Red)
CFM	450	375	300

The units are wired from the factory on low speed. The speed can be changed by rotating the speed switch on the front of the QERV to the desired speed.

# PERFORMANCE AND APPLICATION DATA

## Summer Cooling Performance (Indoor Design Conditions 75° DB / 62° WB)

Ambient O.D.	VENTILATION RATE --- 450 CFM 65% Efficiency						VENTILATION RATE --- 375 CFM 66% Efficiency						VENTILATION RATE --- 300 CFM 67% Efficiency							
	DB/ WB°F	VLT	VLS	VLL	HRT	HRS	HRL	VLT	VLS	VLL	HRT	HRS	HRL	VLT	VLS	VLL	HRT	HRS	HRL	
75	21465	14580	6884	13952	9477	4475	17887	12150	5737	11805	8018	3786	14310	9720	4590	9587	6512	3075		
	105	70	14580	14580	0	9477	9477	0	12150	12150	0	8018	8018	0	9720	9720	0	6512	6512	0
	65	14580	14580	0	9477	9477	0	12150	12150	0	2018	8018	0	9720	9720	0	6512	6512	0	
100	80	31590	12150	19440	20533	7897	12635	26325	12125	16200	17374	6682	10692	21060	9720	12960	14110	5427	8683	
	75	21465	12150	9314	13952	7897	6054	17887	10125	7762	11805	6682	5123	14310	8100	6210	9587	5427	4160	
	70	12352	12150	202	8029	7897	131	10293	10125	168	6793	6682	111	8235	8100	135	5517	5427	90	
	65	12150	12150	0	7897	7897	0	10125	10125	0	6682	6682	0	8100	8100	0	5427	5427	0	
	60	12150	12150	0	7897	7897	0	10125	10125	0	6682	6682	0	8100	8100	0	5427	5427	0	
95	80	31590	97290	21870	20533	6318	14215	26325	8100	18225	17374	5345	12028	21060	6480	14580	14110	4341	9768	
	75	21465	97290	11744	13952	6318	7634	17887	8100	9787	11805	5345	6459	14310	6480	7830	9587	4341	5246	
	70	12352	97290	2632	8029	6318	1711	10293	8100	2193	6793	5345	1447	8235	6480	1755	5517	4341	1175	
	65	9720	97290	0	6318	6318	0	8100	8100	0	5345	5345	0	6480	6480	0	4341	4341	0	
	60	9720	97290	0	6318	6318	0	8100	8100	0	5345	5345	0	6480	6480	0	4341	4341	0	
90	80	31590	7290	24300	20533	4738	15794	26325	6075	20250	17374	4009	13365	21060	4860	16200	14110	3256	10854	
	75	21465	7290	14175	13952	4738	9213	17887	6075	11812	11805	4009	7796	14310	4860	9450	9587	3256	6331	
	70	12352	7290	5062	8029	4738	3290	10293	6075	4218	6793	4009	2784	8235	4860	3375	5517	3256	2261	
	65	7290	7290	0	4738	4738	0	6075	6075	0	4009	4009	0	4860	4860	0	3256	3256	0	
	60	7290	7290	0	4738	4738	0	6075	6075	0	4009	4009	0	4860	4860	0	3256	3256	0	
85	80	31590	4860	26730	20533	3159	17374	26325	4050	22275	17374	2672	14701	21060	3240	17820	14110	2170	11939	
	75	21465	4860	16605	13952	3159	10793	17887	4050	13837	11805	2672	9132	14310	3240	11070	9857	2170	7416	
	70	12352	4860	7492	8029	3159	4870	10293	4050	6243	6793	2672	4120	8235	3240	4995	5517	2170	3346	
	65	4860	4860	0	3159	3159	0	4050	4050	0	2672	2672	0	3240	3240	0	2170	2170	0	
	60	4860	4860	0	3159	3159	0	4050	4050	0	2672	2672	0	3240	3240	0	2170	2170	0	
80	75	21465	2430	19035	13952	1579	12372	17887	2025	15862	11805	1336	10469	14310	1620	12690	9587	1085	8502	
	70	12352	2430	9922	8029	1579	6449	10293	2025	8268	6793	1336	5457	8235	1620	6615	5517	1085	4432	
	65	4252	2430	1822	2764	1579	1184	3543	2025	1518	2338	1336	1002	2835	1620	1215	1899	1085	814	
	60	2430	2430	0	1579	1579	0	2025	2025	0	1336	1336	0	1620	1620	0	1085	1085	0	
75	70	12352	0	12352	8029	0	8029	10293	0	10293	6793	0	6793	8235	0	8235	5517	0	5517	
	65	4252	0	4252	2764	0	2764	3543	0	3543	2338	0	2338	2835	0	2835	1899	0	1899	
	60	0	0	0	0	0	0	0	0	0	0	0	0	0	0	0	0	0	0	

### LEGEND

VLT = Ventilation Load - Total

VLS = Ventilation Load - Sensible

VLL = Ventilation Load - Latent

HRT = Heat Recovery - Total

HRS = Heat Recovery - Sensible

HRL = Heat Recovery - Latent

**Winter Heating Performance**  
(Indoor Design Conditions 70° F DB)

Ambient O.D. DB° F	VENTILATION RATE					
	450 CFM 80% Eff		375 CFM 81% Eff		300 CFM 82% Eff	
	WVL	WHR	WVL	WHR	WVL	WHR
65	2430	1944	2025	1640	1620	1328
60	4860	3888	4050	3280	3240	2656
55	7290	5832	6075	4920	4860	3985
50	9720	7776	8100	6561	6480	5313
45	12150	9720	10125	8201	8100	6642
40	14580	11664	12150	9841	9720	7970
35	17010	13608	14175	11481	11340	9298
30	19440	15552	16200	13122	12960	10627
25	21870	17496	18225	14762	14580	11955
20	24300	19440	20250	16402	16200	13284
15	26730	21384	22275	18042	17820	14612

LEGEND  
WVL = Winter Ventilation Load  
WHR = Winter Heat Recovery

NOTE: Sensible performance only is shown for winter application.

**BARD QH SERIES**  
**WITH ENERGY RECOVERY VENTILATOR**  
**MAINTENANCE PROCEDURES**

**MONTHLY**

1. Inspect mist eliminator prefilter and clean if necessary. This filter is located in the fresh air intake hood on the wall sleeve. This is an aluminum mesh filter and can be cleaned with water and any detergent not harmful to aluminum. To gain access to the prefilter, remove the QERV from the unit and slide filter out of wall sleeve.
2. Inspect unit filter and clean or replace as necessary. This filter is located in the unit. It can be accessed by removing the middle service door on the front of the unit.  
  
Washable filter should be cleaned with dish washing soap and water. Shake off excess water and reinstall. Replace if the washable media becomes uncleanable or starts to deteriorate.  
  
Throw away filter should be replaced after they become dirty and is dependent on the application.
3. Inspect energy recovery ventilator for proper wheel rotation and dirt buildup. This can be done in conjunction with Item 2 above. Energize the energy recovery ventilator after inspecting the filter and observe for proper rotation and/or dirt buildup.

Clean as necessary. Clean as follows: Disconnect all power to unit. Remove the middle service door of the unit to gain access to the energy recovery ventilator. Remove the front access panel on the ventilator. Unplug Amp connectors to cassette motors. Slide energy recovery cassette out of ventilator. Use a shop vacuum with brush attachment to clean both sides of the energy recover wheels.

NOTE: Discoloration and staining of the wheel does not affect its performance. Only excessive buildup of foreign material needs to be removed.

**SEMIANNUALLY**

1. Inspect condenser coil for dirt and clean if necessary. Clean all loose dirt, plant matter, cobwebs, and/or insects from both sides of the coil with a shop vacuum. Take care not to damage or bend coil fins. For grease or tough dirt a commercial foaming coil cleaner suitable for use on aluminum fins should be used. Follow instructions on the coil cleaner. *Do not* use a high pressure hose or power cleaner.

# HUB ASSEMBLY WITH SLEEVE BEARING

FIGURE 1

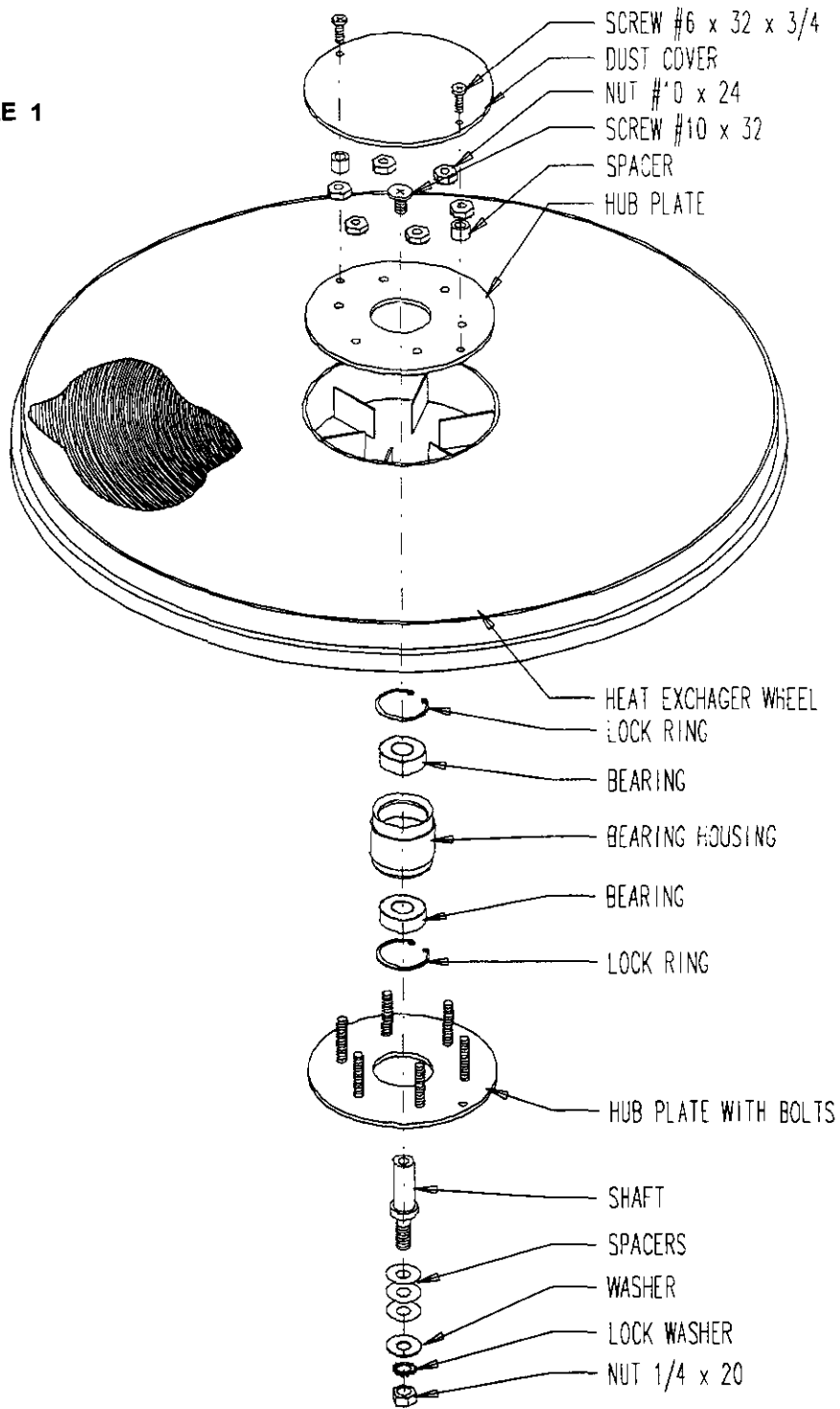

MIS-845

MIS-845

