

INSTALLATION AND OPERATING INSTRUCTIONS FOR OIL-FIRED FORCED AIR FURNACES

SOF-SERIES OIL HORIZONTALS

CAUTION:

Read and carefully follow all installation, start-up, operation and maintenance instructions. This installation must conform to all state and local codes, which may differ from this manual.

WARNING:

RISK OF EXPLOSION OR FIRE

FOR YOUR SAFETY

DO NOT STORE OR USE GASOLINE OR OTHER FLAMMABLE LIQUIDS OR VAPORS IN THE VICINITY OF THIS OR ANY OTHER APPLIANCE.

DO NOT ATTEMPT TO USE ANY FUEL OTHER THAN #1 OR #2 OIL WITH THIS FURNACE.

IMPORTANT:

The following instruments must be used to adjust the burner on start-up. Failure to use instrument will void the warranty.

Carbon dioxide (CO₂) tester,

Bacharach model 10-5000
Dwyer Model 1101
or equivalent.

- or -

Oxygen (O₂) tester,

R.W. Beckett model C-5
or equivalent.

Draft gauge,

Bacharach model 13-3000
Dwyer model 172
or equivalent.

Smoke tester,

Bacharach model 21-7006
Dwyer model 920
or equivalent

Thermometer,

Bacharach model 12-7014
Dwyer model 920
or equivalent

Oil pressure gauge

Sid Harvey model P116
or equivalent

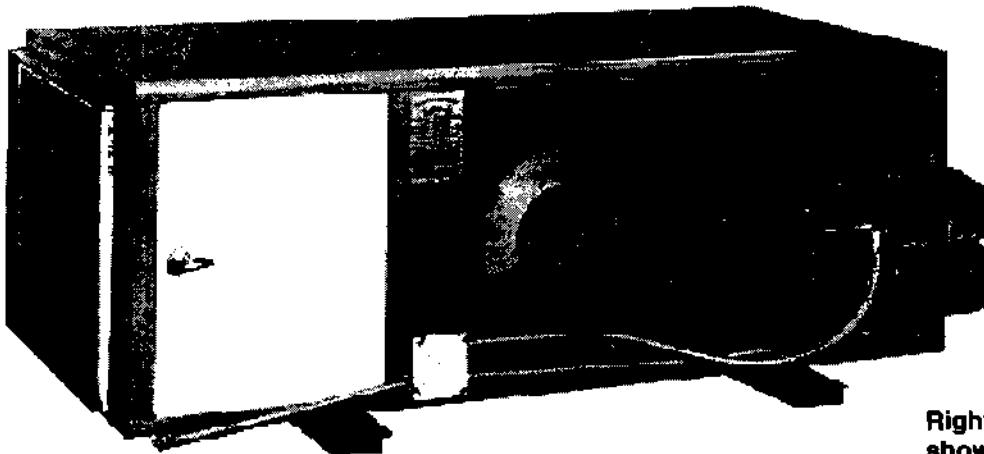

Right hand discharge as shown is standard from the factory. See instructions for converting to left hand discharge.

INSTALLER: Give this booklet to the user.

USER: Keep this booklet for future reference.

To the best knowledge of the manufacturer the information in this manual is correct at time of publication. Specifications subject to change without notice.

Manual: 2100-299A
Rev.
Issue: 01-12-98
File: Tab 3

INDEX:

Air for combustion and ventilation	5
Air filters	4
Burner adjustment	6
Burner installation	6
Converting horizontal to LH discharge	6
Cooling coils	4
Draft-O-Stat™ installation	6
Ductwork installation	4
Emergency shutoff	3
Fan and limit installation	4
Flue connection	5
Fuel	3
Fuel booster pumps	5
Fuel piping	5
Installation clearances	3
Installation standards	2
Lighting and shutdown instructions	6
Location and placement of furnace	3
Rate plate information	2
Room thermostat	4
Seasonal maintenance	7
Wiring	3

RATE PLATE INFORMATION:

Record the following information for your convenience:

Model number _____
Serial number _____
Nozzle size _____ GPH _____ ° _____
Date installed _____
Installer/service co. _____
Address _____
City/state/ZIP _____
Phone _____

The model number, serial number and nozzle size information is on the furnace rating plate, which is attached to the furnace cabinet near the oil burner.

GENERAL:

The warnings shown on the front cover of this manual and the information on the following pages is important and should be completely read and understood by the operator of this equipment. Please take the few minutes necessary to read these instructions, and if you have any questions ask your installer to answer them.

Your new furnace has been manufactured and tested with utmost care and will give years of trouble free service when properly installed. These instructions are intended for the use of qualified individuals specifically trained and experienced in the installation of oil fired equipment. Some localities require that installation and service persons be licensed. Persons who are not qualified or licensed should not attempt to install this equipment or interpret these instructions. Please note that an improperly done installation can result in unsatisfactory performance of the furnace and may also cause property damage or bodily injury. The installation must conform with state and local building codes, or in the absence of local codes with the current edition of the following national standards:

1. Installation of Oil Burning Equipment, NFPA #31¹.
2. National Electric Code, NFPA #70.
3. Chimneys, Fireplaces, Vents and Solid Fuel Burning Appliances, NFPA #211.
4. Installation of Air Conditioning and Ventilating Systems, NFPA #90A.
5. Load Calculation-Residential, ACCA manual J; (commercial-ACCA manual N).²
6. Duct Design-Residential, ACCA manual D; (commercial, SMACNA HAVC Systems-Duct Design).³

To be sure that the furnace is large enough to heat the building that it is to be installed in heat loss calculations should be done. It is recommended that the calculations follow the procedure outlined in ACCA manual J or N.

¹National Fire Protection Association, Batterymarch Park, Quincy, MA 02269

²Air Conditioning Contractors of America, 1228 17th St. NW, Washington, DC 20036

³Sheet Metal & Air Conditioning Contractor's National Association, P.O. Box 70, Merrifield, VA 22116

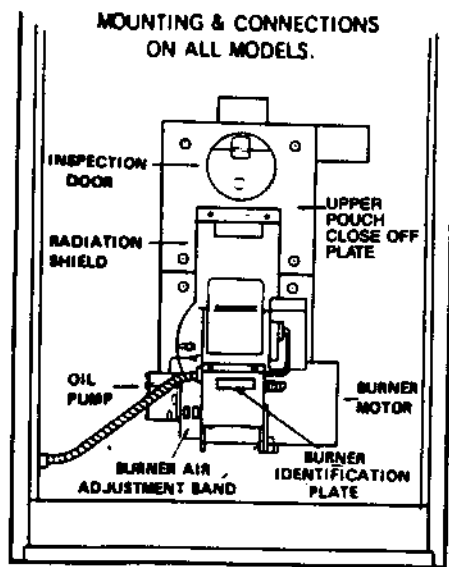
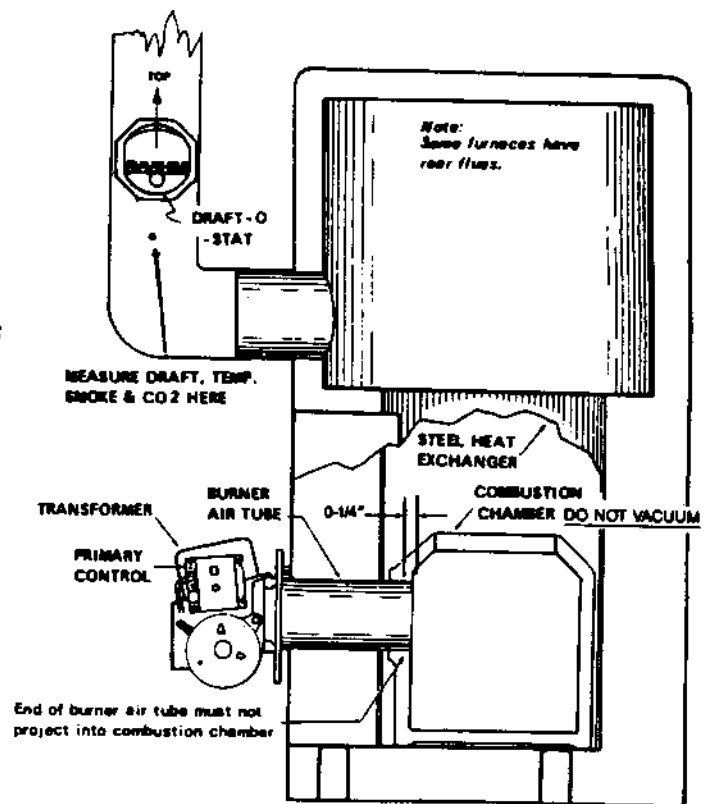

FIGURE C



FUEL:

This furnace is designed for use with No. 1 or No. 2 fuel oil as specified in ASTM D396. **DO NOT ATTEMPT TO USE GASOLINE, WASTE OIL OR ANY FUEL OTHER THAN No. 1 OR No. 2 OIL.** Use of any other fuel may result in an explosion, personal injury or property damage and will void the warranty.

EMERGENCY SHUTOFF OF FURNACE:

If there is an emergency you **MUST** know how to turn off the fuel and electricity. Find out how to do this before the emergency happens. Have a qualified installer, service agency or fuel supplier show you the location and operation of the fuel and electrical shutoff devices. In the event of an emergency try to shut off the fuel supply before shutting off the electricity.

PACKAGING FOR SHIPMENT:

All UFO and ACO series furnaces (except ACO 350) are shipped in one carton. All ACO 350, ACOV, OCF and SO furnaces are shipped in two cartons.

LOCATION AND PLACEMENT OF UNIT:

This furnace may be installed in a building constructed on site or a manufactured building completed on site. It is not designed or intended for use outdoors or in a mobile home, trailer or recreational vehicle. In choosing a location for the unit observe these important points:

1. The furnace should be located to provide a flue connection that is as short as possible.
2. Clearances as shown on the furnace rating plate and in this manual must be maintained, and adequate clearance must be provided for easy service of the burner, blower and controls.
3. A furnace installed in a garage must be located so that the burner and ignition source are located at least 18 inches above the floor, and the furnace must be protected to prevent physical damage from vehicles.

If possible the unit should be left in the carton until it is moved to the final installation location. When removing the carton care should be taken to avoid scratching or marring the cabinet. All loose parts should be checked against the packing list.

The unit must be set on a firm level foundation. If necessary place shims under the furnace base to level the unit. If the furnace will be subject to wet floors or extreme dampness it is recommended that the unit be placed on a concrete base 2 or 3 inches high and approximately 2 inches longer and wider than the furnace.

INSTALLATION CLEARANCES:

There are certain minimum installation clearances from the furnace cabinet and the plenum on top of the furnace to any combustible materials. It is the installer's responsibility to see that these clearances are allowed for during the installation. It is the user's responsibility to make sure that these clearances are always maintained after the installation is complete.

Be sure to observe the following:

1. **DO NOT STORE OR USE FLAMMABLE LIQUIDS OR VAPORS (THESE INCLUDE BUT ARE NOT LIMITED TO GASOLINE, PAINT AND SOLVENTS) IN THE FURNACE AREA.** Gasoline and many other flammable vapors are heavier than air and can travel great distances along floors.
2. Do not allow any combustible materials (these include but are not limited to paper, wood, clothing and plastics) to be placed or stored within the minimum clearances.

Minimum clearance (distance) to combustible materials:

MODEL TOP FRONT SIDES REAR FLUE TYPE FLOORING

SOF	6	24	6	6	18	Noncombustible
-----	---	----	---	---	----	----------------

*Be sure to leave service clearance for the blower.

**May be installed on combustible flooring with special insulating base kit.

Please note that a 30" service clearance should be allowed for in front of the furnace. This clearance should be present after opening the door of an alcove or closet installation.

ELECTRIC WIRING:

CAUTION: For your personal safety turn off electricity at the service entrance panel before making any electrical connections. All electric wiring and connections made in the field must be in conformance with local codes and NFPA #70. The electric supply must be 120 volts, 60 hertz, and should be made to a separate fused circuit using approved wire, 12 gauge minimum. A service shut-off switch should be installed in the circuit within easy reach of the furnace. The furnace is factory wired with type AWM 105° C thermoplastic wire. Replacement wiring must be done with equivalent type and gauge wire.

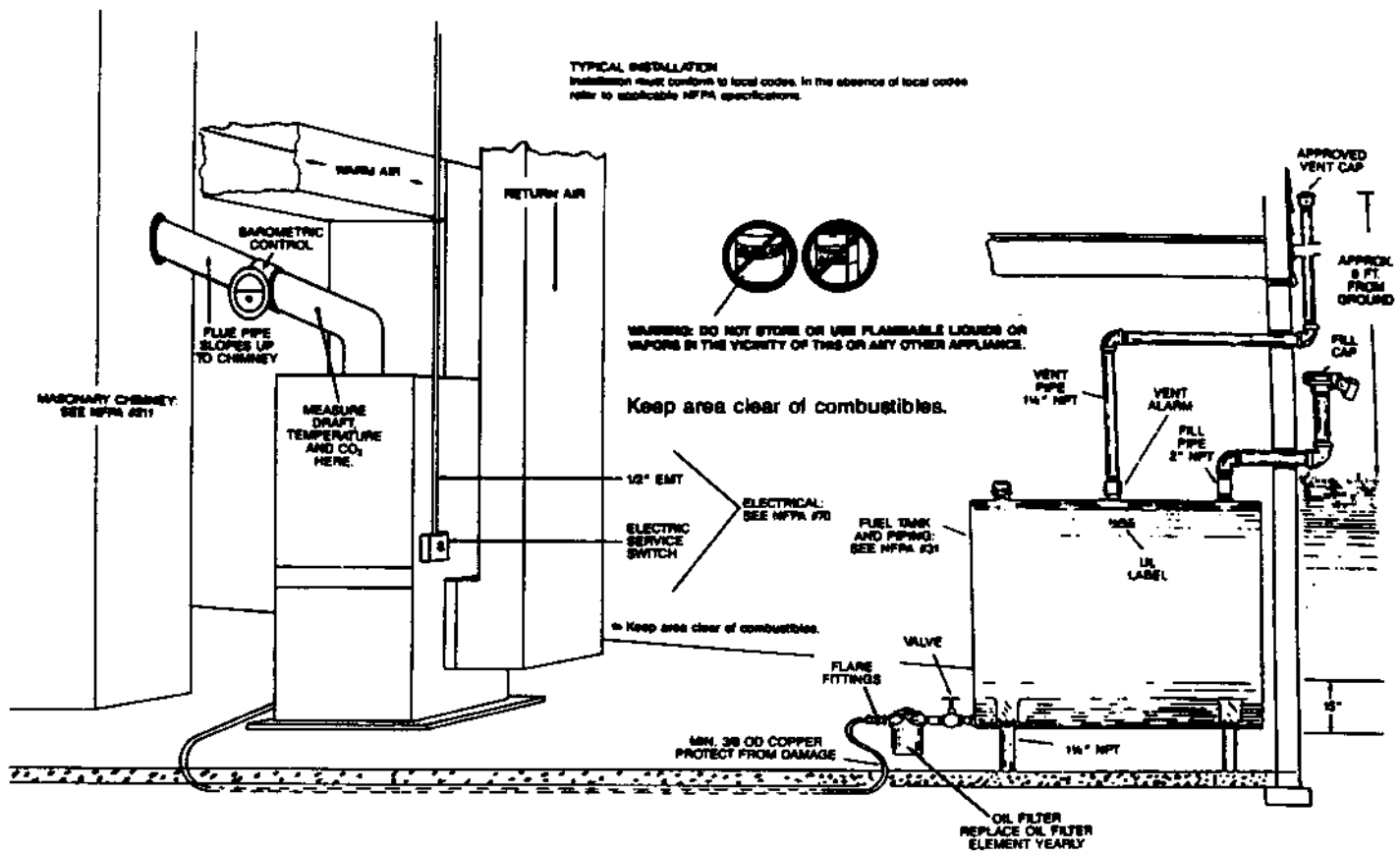

FIGURE D

FAN & LIMIT:

Install the fan and limit at the point designated by the label on the furnace. (On models ACOV 175, ACOV 350 and ACO 350 install the fan and limit in the plenum 6 inches above the top of the furnace and 6 inches in from the left side.) Air conditioning coils must always be installed above the fan and limit control. For the most economical operation set the fan "off" temperature at the lowest setting consistent with the occupants' comfort, usually 100° F. Set the fan "on" temperature 25-30 higher than the fan "off". The limit setting is fixed at the factory, DO NOT ATTEMPT TO ADJUST.

DUCTWORK:

These furnaces are not designed to operate without ductwork. No furnace will operate or heat properly if the ductwork it is attached to is not sized and installed correctly. All ductwork must be designed and installed in accordance with local codes and the current edition of NFPA #90A and ACCA manual D or SMACNA HVAC Systems-Duct Design. All warm air runs should have dampers installed so the system may be balanced room by room. Dampers should be adjusted to provide a minimum 0.20 and a maximum 0.50 inches water column external static pressure in the warm air plenum. The temperature rise in the furnace must also be checked, and the motor speed adjusted to obtain a temperature rise within the range specified on the rating plate.

When a furnace is installed so that the supply ducts carry air circulated by the furnace to areas outside the space containing the furnace, the return air must also be connected by a duct(s) sealed to the furnace and terminating outside of the space containing the furnace.

AIR FILTERS:

Air filters are necessary to keep the blower wheel, blower motor and air conditioning coil (if used) clean. Dirt accumulation on any of these components can significantly reduce efficiencies. Filters should be checked monthly and cleaned or replaced as needed. When replacing filters always use filters rated for a minimum air velocity of 600 FPM.

Furnace model	BTU Input	Filter size table	
		Filter size	Qty
SOF075, 100	90,000-120,000	20 x 20 x 1	1
SOF120, 140	140,000-175,000	20 x 25 x 1	1
SOF175	230,000	16 x 25 x 1	2
SOF265	350,000	16 x 16 x 1	4

COOLING COILS:

When cooling coils are used in conjunction with the furnace the following should be observed:

The furnace must be installed in parallel with or on the upstream side of the cooling unit to prevent condensation in the heating element. With a parallel flow arrangement the dampers or other means used to control the flow of air must be adequate to prevent chilled air from entering the furnace. If dampers are manually operated they must be equipped with a means to prevent the operation of either unit unless the dampers are in the full heat or cool position.

To keep airflow at maximum, low pressure drop coils should be used. Be sure the coil drain pan is adequate to catch the condensation. The pan must slope toward the drain hole so that condensate does not drip on and rust the heat exchanger. Heat exchanger damage from condensate is not covered under the warranty. In upflow furnaces coils must always be installed above the fan and limit control.

THERMOSTAT:

The thermostat should be installed on an inside wall and located in the natural circulating path of the room air. Locations which would expose the thermostat to cold air, drafts from windows, doors or other openings leading to the outside, or to air currents from warm

TYPICAL CHIMNEY CONDITIONS APT TO RESULT IN BACK-DRAFTS

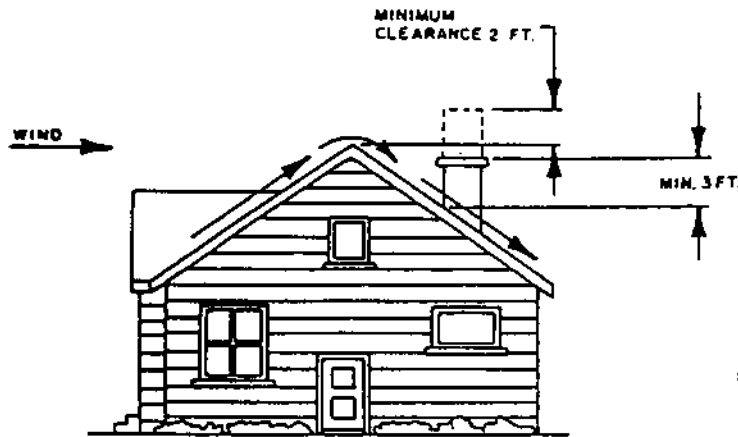

FIGURE E

or cold air registers should be avoided. Do not locate the thermostat in an area exposed to direct sunlight. The hole in the wall that the thermostat wires pass through should be sealed to prevent drafts that could affect the thermostat. Set the thermostat heat anticipator to the thermostat current draw rating listed on the burner primary control.

COMBUSTION AND VENTILATION AIR:

Adequate flow of combustion and ventilation air must not be prevented from reaching the furnace. A furnace installed in a confined space, tightly constructed building or a building with exhaust fans must have provisions made for combustion/ventilation air. When the air supply from the furnace room or nearby area is inadequate, an opening in the outside wall shall be provided and furnished with properly screened metal sleeves. The opening must have a minimum of one square inch per 1,000 BTU/hour of output rating and must never have less than 100 square inches of free area. See figure B. Furnaces installed in closets or small utility rooms should have an air inlet near the top and bottom of the room. Each of these openings should have a minimum of one square inch per 1,000 BTU/hour of input rating, and each must never have less than 100 square inches of free area. Refer to NFPA #31 for more detailed information.

FUEL PIPING:

All fuel piping must be in conformance with local codes, or in the absence of local codes refer to NFPA #31. A manual shut-off valve and fuel filter must be installed in the supply line. The fuel filter must be capable of filtering particles 50 microns or smaller. A safety valve (equivalent to a Webster OSV series) that allows fuel to flow only when there is a sustained vacuum on the burner side of the valve should be installed in the fuel line. Fuel lines must not be smaller than 3/8" OD copper tubing. To eliminate air leakage fuel lines should be a continuous length from the tank to the burner, and flare fittings must be used at all connections. On threaded connections use pipe dope that is resistant to fuel oil (Rectorseal #5, Permatex or equivalent). DO NOT USE TFE JOINT TAPE. Keep in mind that 95% of all pump and burner troubles are caused by three factors; air leaks in the fuel lines, improperly sized fuel lines and dirty fuel. Refer to figure D on page 4 and pump installation data on page 8.

BOOSTER PUMPS:

If it is necessary to use a booster pump in the oil supply line the pump must be installed in accordance with the manufacturer's instructions and NFPA #31. THE FUEL PRESSURE AT THE BURNER PUMP INLET MUST NEVER EXCEED 3 PSI. A safety valve as described in the Fuel Piping section must be installed in the fuel line when using a booster pump.

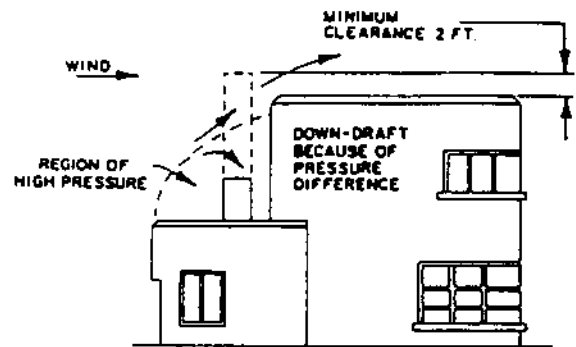

COMMON CHIMNEY TROUBLES

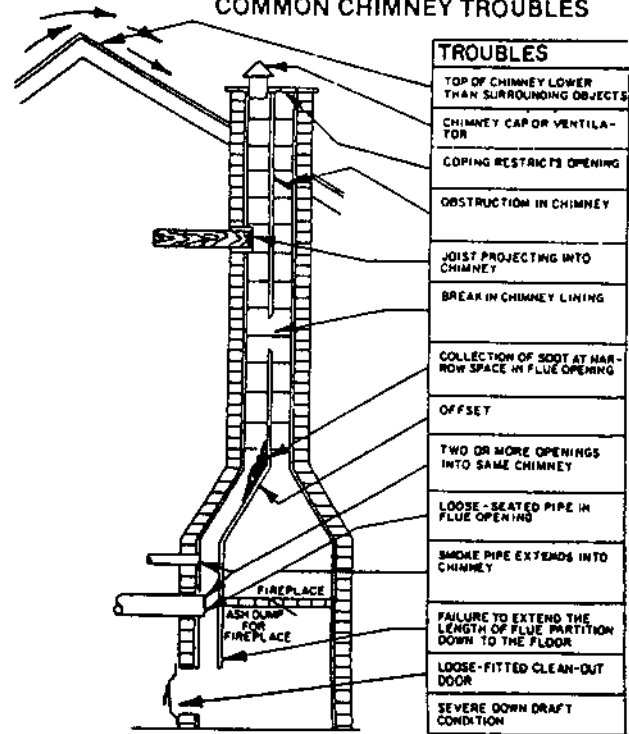

FLUE CONNECTION:

It is important that a good vent connection be made to all furnaces to minimize possible spillage of flue gasses into the building. The vent connection must be made in conformance with local codes, or in the absence of local codes refer to NFPA #211. The furnace must be connected to a masonry chimney conforming to NFPA #211 or a prefabricated "all fuel" chimney conforming to UL103/108HT. The chimney must be in good condition and adequately sized. The flue pipe to the chimney must be the same size as the outlet of the flue connection of the furnace. Never put a reducer in the flue pipe. Install the Draft-O-Stat packed with the furnace in the flue pipe. Flue pipe should slope upward to the chimney at the minimum rate of 1/4 inch per foot. The flue connection should be as short and straight as possible and should not have more than 3 elbows. The horizontal run of the flue pipe must not exceed 2/3 the height of the vent or chimney. All flue pipe joints must be secured using three metal screws spaced at equal intervals around each joint, and horizontal portions of the flue pipe must be supported at three foot intervals using wire or sheet metal hangers.

WARNING: DO NOT CONNECT THE FURNACE FLUE PIPE TO A VENT OR CHIMNEY IN CONJUNCTION WITH AN APPLIANCE THAT USES A MECHANICAL DRAFT SYSTEM OPERATING AT POSITIVE PRESSURE.

Sidewall venting of this furnace is not permitted unless a power sidewall vent kit is used. Two manufacturers of these kits are Tjernlund Products and Field Controls. The sidewall venter must be installed in accordance with the manufacturer's instructions and adjusted to obtain a 0.02" WC overfire draft. **CAUTION: IF THE BURNER FIRES POORLY AND PRODUCES A SOOTY FLAME IT IS POSSIBLE THAT THE WALL OF THE STRUCTURE WILL BE SOOTED WHEN USING A SIDEWALL VENT KIT.**

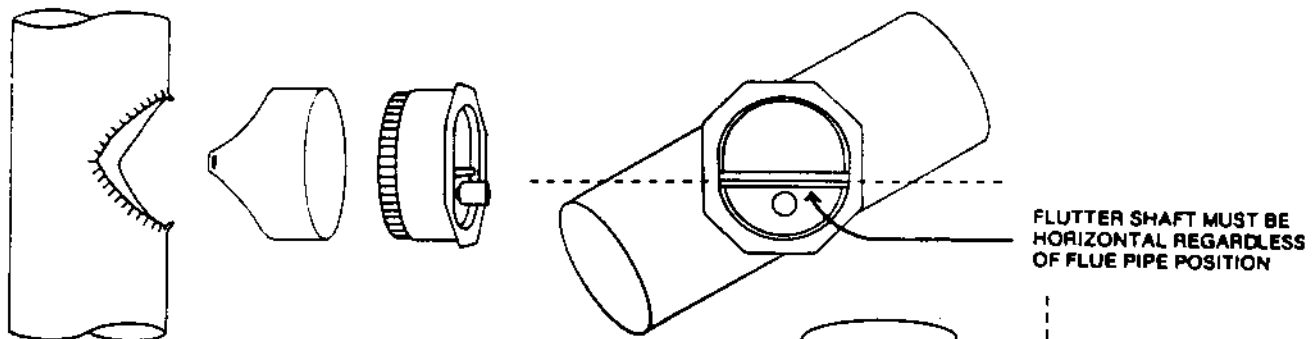

FIGURE F

DRAFT-O-STAT INSTALLATION:

The Draft-O-Stat™ barometric control is used to maintain a constant amount of draft through the furnace, allowing the burner to be adjusted for maximum efficiency. Install the control in the flue pipe 12 to 18 inches from the furnace cabinet. Place the thimble (saddle) on the flue pipe, making sure the face of the thimble is vertical (plumb). Mark around the outside edge of the thimble using a scribe or marker. Remove the thimble and draw another line about 1/2" inside the first. Cut out the flue pipe along the inner line. Cut notches about 3/8" apart around the edge of the hole to form tabs. At the twelve, three, six and nine o'clock positions bend up one tab. Place the 'Z' clip in one slot on the tail of the thimble and attach the metal strap to the clip using the 1/4-20 screw and nut.

Place the thimble on the flue pipe over the upright tabs and run the strap behind the flue pipe to the open slot on the thimble. Run the strap between the flue pipe and the thimble tail and through the slot, pull the strap tight and bend the strap back against itself. Tighten the screw on the 'Z' clip and bend the rest of the tabs up against the inside of the thimble. Mount the Draft-O-Stat in the thimble, making sure the face of the control is vertical (plumb) and the flutter shaft is horizontal. Secure the Draft-O-Stat to the thimble using metal screws through the side of the thimble. Be sure that the screws do not interfere with the action of the flutter. Start the furnace and make the preliminary burner adjustments, then adjust the balance weight on the flutter to obtain an over-fire draft of 0.02" WC. Perform the final burner adjustments after adjusting the over-fire draft. Refer to figure F.

OIL BURNER INSTALLATION:

Proper installation of the oil burner is important to prevent damage to the furnace and burner. Remove the upper pouch close-off plate, then install the burner in the mounting hole in the lower plate. See figure C. Be sure the burner air tube is properly aligned in the combustion chamber entry hole. THE END OF THE BURNER AIR TUBE MUST NOT PROJECT PAST THE INNER FACE OF THE COMBUSTION CHAMBER. Replace the upper pouch close-off plate. If a two pipe fuel supply system is used, insert the bypass plug in the fuel pump. Refer to figure C.

BURNER ADJUSTMENT:

IT IS NOT POSSIBLE TO ADJUST AN OIL BURNER WITHOUT USING THE PROPER INSTRUMENTS. An improperly adjusted oil burner will cause inefficient and troublesome operation and may damage the furnace or cause personal injury. Failure to follow the adjustment procedure outlined below will void the warranty. Burner adjustments should be made by an experienced service contractor.

The following instruments are needed:

Carbon dioxide tester (CO₂); Bacharach model 10-5000, Dwyer model 1101, or equivalent. -OR-

Oxygen (O₂) tester, Beckett model C-5 or equivalent.

Draft gauge; Bacharach model 13-3000, Dwyer model 172, or equivalent.

Smoke tester; Bacharach model 21-7006, Dwyer model 920, or equivalent.

Oil pressure gauge; Sid Harvey model P116 or equivalent.

1. Start the burner and let it run for 15 minutes. Adjust the air band to obtain a flame without smoky tips. Adjust the fuel pump pressure to 140 PSI.
2. Adjust the barometric draft damper (Draft-O-Stat) to obtain an overfire draft of 0.01 to 0.02" water column.
3. Adjust the combustion air band at the side of the burner to obtain the highest CO₂ (lowest O₂) with a zero to a trace of smoke reading. The smoke reading must never exceed a trace and the CO₂ should be minimum of 9%. (O₂ maximum of 8.5%)
4. Record the net stack temperature (net = actual flue gas temperature minus the room air temperature). Record the CO₂ and overfire draft readings.

Net stack temperature _____ °F. Smoke reading _____

Overfire draft _____ "WC. CO₂ _____ % O₂ _____ %

All temperature, CO₂, smoke and draft measurements (except overfire draft) must be made in the flue pipe between the flue outlet and barometric control. See figure C.

CONVERTING HORIZONTALS TO LEFT HAND DISCHARGE:

Oil horizontals are normally shipped as right hand discharge units. To convert to a left hand discharge:

1. Remove the blower and blower division panel, rotate both 180° and reinstall in the cabinet (belt drive units only).
2. Drill a 1" diameter hole in the front panel of the cabinet on the side opposite the standard location for the fan and limit control.
3. Relocate the wiring harness to the opposite side of the cabinet.
4. Place the 5/16-18 burner mounting screws in the correct holes on the burner mounting plate so that the burner can be mounted upright.

See Figure G on page 12.

LIGHTING AND SHUTDOWN INSTRUCTIONS:

WARNING: SHOULD OVERHEATING OCCUR, OR THE SUPPLY FAIL TO SHUT OFF, SHUT OFF THE MANUAL VALVE BEFORE SHUTTING OFF THE ELECTRICAL SUPPLY.

To light the burner:

1. DO NOT ATTEMPT TO LIGHT THE BURNER USING A MATCH OR ANY OTHER MANUAL METHOD.

- Turn the room thermostat to the lowest setting. Make sure all safety lockouts have been reset. Make sure the control and blower doors are in place.
- Make sure there is fuel in the tank and the fuel supply valve is turned on. Make sure the electric supply is turned on.
- Set the room thermostat to the desired temperature.
- If the burner does not light repeat steps 2 through 4. If the burner does not light after 4 tries shut down the furnace and call a qualified service person.

To shut down the furnace:

- Set the room thermostat to its lowest setting.
- Shut off the manual fuel valve and the electrical supply.

SEASONAL MAINTENANCE REQUIREMENTS:

WARNING: THE AREA AROUND THE FURNACE MUST BE KEPT FREE AND CLEAR OF FLAMMABLE LIQUIDS AND VAPORS (GASOLINE, PAINT, PAINT THINNER, SOLVENTS, ETC.) AND COMBUSTIBLE MATERIALS (WOOD, PAPER, CLOTHING, PLASTICS, ETC.).

CAUTION: SHUT OFF THE ELECTRICAL SUPPLY BEFORE PERFORMING ANY SERVICE. AT THE BEGINNING OF EACH HEATING SEASON:

- Check the air filters. Dirty air filters should be washed if they are a washable type and replaced if they are a disposable

type. Always replace filters with the same size and type. Also check the air filter frequently during the heating season and clean or replace as necessary.

- If the furnace has a direct drive blower the motor is permanently lubricated. Oil belt drive motors with 2 or 3 drops of lightweight nondetergent oil in each oil cup. Do not over oil.
- On belt drive units check the belt for cracks or wear and replace if needed. Do not over-tighten the belt. It should be possible to deflect the belt 1/2 inch at the mid-point between the pulleys. Check to see that the pulley sheaves are clean and that they are aligned with each other. Check the blower shaft bearings for wear and replace if needed.
- Lubricate the burner motor with 2 or 3 drops of lightweight oil. Do not over oil.
- Inspect the burner air inlet end squirrel cage and clean if needed.
- Replace the fuel filter element.
- Check to see that the flutter on the barometric control swings freely.
- Inspect the flue pipe for rust-through or scale and replace if needed.
- Inspect the chimney for obstructions or defects and repair as needed.

To insure safe and dependable operation of this furnace it is recommended that a qualified service company inspect the furnace periodically.

**EFFICIENCY CHART FOR NO. 2 FUEL OIL
NET STACK TEMP. (degrees F°)**

	300°	350°	400°	450°	500°	550°	600°	650°	700°	750°	800°	850°	900°
15	87½	86½	85½	84½	83½	82	81	79¾	78¾	77½	76½	75½	74½
	87½	86¼	85	84	83	81¾	80¾	79¼	78½	77¼	76	75	73¾
14	87¼	86	84¾	83¾	82¾	81½	80¼	79	78	76¾	75½	74½	73
	87	85¾	84½	83½	82½	81¼	80	78¾	77½	76¼	75¼	74	72¾
13	86¾	85½	84¼	83¼	82	80¾	79½	78¼	77	75¾	74½	73½	71¾
	86½	85¼	84	83	81¼	80¼	79	77¾	76½	75¼	73¾	72¾	71
12	86¼	85	83¾	82½	81¼	79¾	78½	77¼	75¾	74½	73	71½	70¼
	86	84¾	83½	82	80¾	79¼	78	76½	75¼	73¾	72¾	70¾	69½
11	85¾	84½	83	81½	80¼	78¾	77¼	75¾	74½	73	71½	70	68½
	85½	84	82½	81	79½	78	76½	75	73¾	72	70½	69	67½
10	85	83¾	82	80½	78¾	77¼	75¾	74¼	72¾	71	69½	68	66¼
	84½	83	81½	79¾	78	76½	75	73¾	71¼	70	68¼	66¾	65
9	84	82¼	80¾	79	77¼	75¾	74	72¼	70¾	68¾	67	65¼	63¼
	83½	81¾	80	78¼	76½	74¾	73	71¼	69½	67½	65½	63¾	62
8	83	81	79¾	77½	75½	73¾	71¾	70	68	66	64	62	60
	82¼	80¼	78½	76½	74½	72½	70½	68½	66½	64¼	62¼	60	58
7	81¾	79¾	77¼	75¼	73¼	71	69	67	64¾	62½	60¼	57¾	55½
	80¾	78½	76¼	74	71¾	69½	67¼	65	62¾	60¾	57¾	55½	53
6	79¾	77¼	75	72½	70	67¾	65¾	62¾	60¾	57½	55	52½	50
	78½	76	73½	71	68	65½	63	60¾	57½	54½	51¾	49	46½
5	77¼	74½	71¾	69	65¾	63	60	57	54	51	48	45½	42¼
	75¾	72½	69	66¼	63	60	56¾	53½	50¼	47	43¾	40¼	36¾
4	73¾	69¾	66¾	62¾	59¼	55¾	52	48½	45	41¼	37½	33¾	30

PUMP INSTALLATION INFORMATION

**FOR A-7000 SINGLE STAGE AND B-8000 TWO-STAGE FUEL UNITS
MODELS A1 & B1 FOR 1725 RPM, BLACK LABEL
MODELS A2 & B2 FOR 3450 RPM, WHITE LABEL**

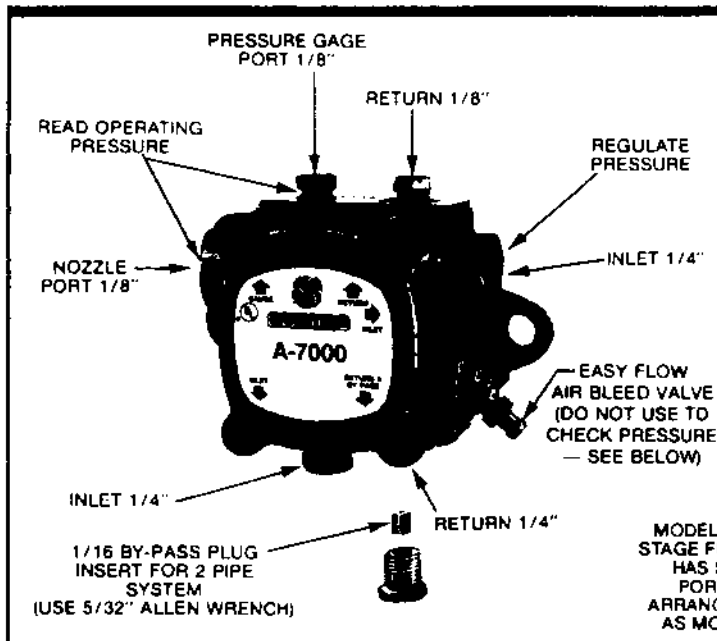

FIGURE 1

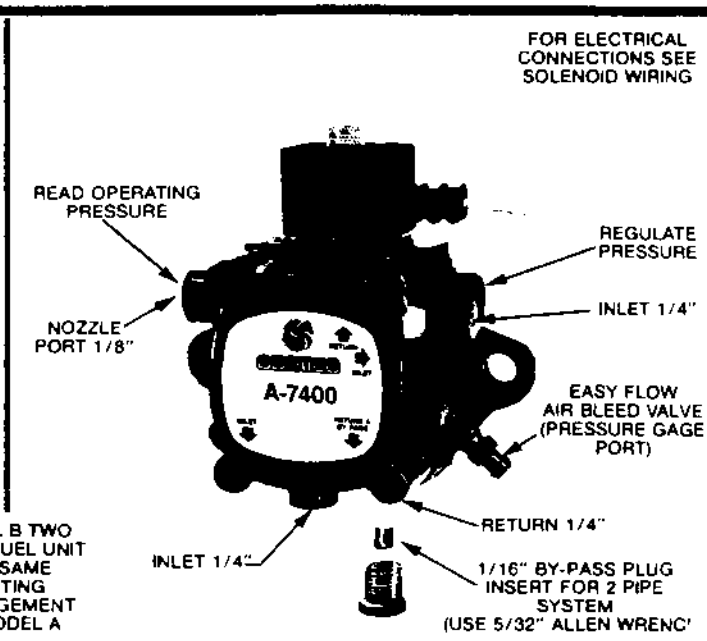

FIGURE 2

ONE-PIPE SYSTEM

DO NOT INSTALL BY-PASS PLUG! Connect inlet line to pump inlet. Start burner. Arrange primary burner control for continuous operation during purging. Open easy flow bleed valve 1 turn CCW. Bleed unit until all air bubbles disappear — **HURRIED BLEEDING WILL IMPAIR EFFICIENT OPERATION OF UNIT.** Tighten easy flow bleed valve securely. (Figure 4)

TWO-PIPE SYSTEM

REMOVE 1/16" BY-PASS PLUG FROM PLASTIC BAG ATTACHED TO UNIT. Remove 1/4" plug from return port. Insert by-pass plug (See Figure 1 or 2). Attach return and inlet lines. Start burner — Air bleeding is automatic. Opening Easy Flow Air Bleed Valve will allow a faster bleed if desired. Return line must terminate 3-4" above supply line inlet (See Figure 5). Failure to do this may introduce air into the system and could result in loss of prime.

SOLENOID WIRING

DISCONNECT POWER SUPPLY BEFORE WIRING TO PREVENT ELECTRICAL SHOCK OR EQUIPMENT DAMAGE. Lead wires on these devices are long enough to reach the junction box on most burner installations. Wire solenoid in parallel with burner motor (See Figure 3). All electrical work should be done according to local and national codes. (Solenoid 115V, 0.1A, 60 Hz)



FIGURE 3

GENERAL INFORMATION • ALL SYSTEMS

IMPORTANT INFORMATION Long or oversized inlet lines may require the pump to operate dry during initial bleeding period. In such cases, the priming may be assisted by injecting fuel oil into the pump gearset. Under lift conditions, oil lines and fittings must be air tight. To assure this, "Pipe Dope" may be applied to both the used and unused inlet and both return fittings. **DO NOT USE TEFLON TAPE!! DO NOT USE COMPRESSION FITTINGS!!**

MOUNTING POSITION Model "A" Single Stage Fuel Unit may be mounted in any position. Model "B" Two Stage Fuel Unit may be mounted in any position except upside down (1/8" ports pointed down).

VACUUM CHECK A Vacuum Gage may be installed in either of the 1/4" inlet ports or in the 1/8" return port (on single pipe installations), whichever is most convenient. The Model "A" pump should be used where the vacuum does not exceed 6" hg. single pipe and 10" hg. two pipe. The Model "B" should be used where vacuum does not exceed 15" hg. Remember, running vacuum is the total of all pressure drops (ΔP) in the system from tank to inlet of pump.

PRESSURE CHECK If a pressure check is made use GAGE PORT OR NOZZLE PORT. **DO NOT USE EASY FLOW BLEED VALVE PORT FOR THE 7000 SERIES.** The Easy Flow Bleed Valve Port contains pressure higher than operating pressure. Setting pump pressure with gage in the Easy Flow Bleed Valve Port results in **WRONG** operating pressure. The 7400 is an exception (See Figure 2).

CUTOFF PRESSURE Average cutoff pressure for A and B fuel units is 80 psig. To check cutoff pressure, install pressure gage in nozzle port. Run burner for short period of time. Shut burner off. Gage shows cutoff pressure.

CAUTION

Pressurized or gravity feed installations must not exceed 10 P.S.I. on inlet line or return line at the pump. A pressure greater than 10 P.S.I. may cause damage to the shaft seal.

ONE-PIPE SYSTEM • MODEL A

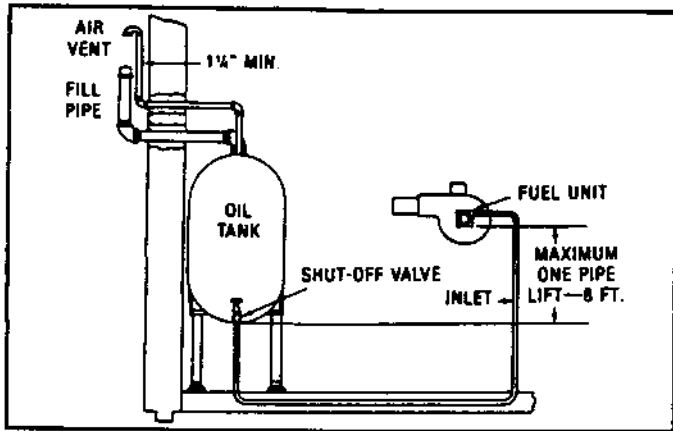

FIGURE 4

The SUNTEC MODEL "A"-70 FUEL UNIT may be installed ONE-PIPE with Gravity Feed or Lift.

The maximum allowable lift is 8 ft. — See Figure 4.

IMPORTANT: One-pipe installations must be absolutely air tight or leaks or loss of prime may result. Bleed line and fuel unit completely. Bleed for 15 seconds after last air is seen from easy flow to be certain lines are air free.

L = Line Length in Feet H = Head in Feet O = Firing Rate in GPH

$3/8"$ line L = $6 - .75H$
 .0086 O

$1/2"$ line L = $6 - .75H$
 .00218 O

If tank is above pump change - to +. Fittings, valves, and filters will reduce total length allowed.

TWO-PIPE SYSTEM • MODEL A AND B

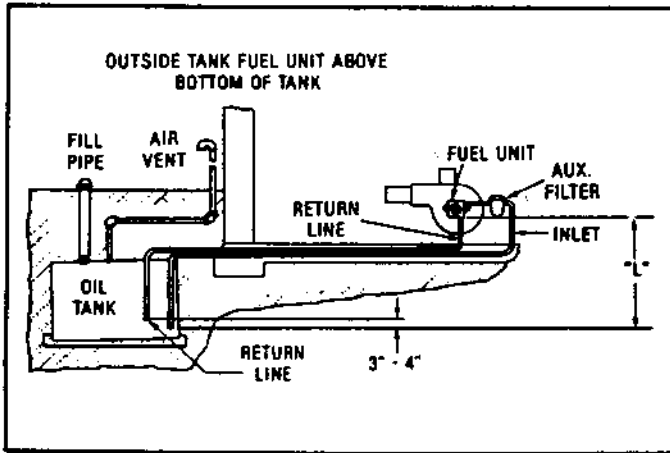
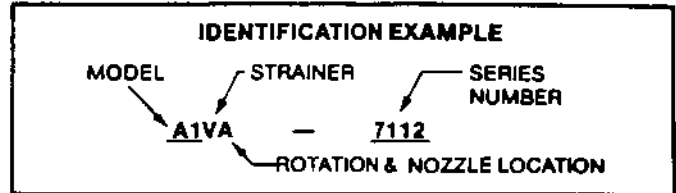

FIGURE 5

Always terminate return line as shown in Figure 5. Line lengths include both vertical and horizontal lengths.

PUMP USAGE IDENTIFICATION



A		
MODEL	MAX NOZZLE CAPACITY (GPH) AT 100 PSI	RPM
A1V-7100	3	1725
A2V-7100	3	3450
A2V-7400	3	3450
A1Y-7900	7	1725
A2Y-7900	7	3450

B		
MODEL	MAX NOZZLE CAPACITY (GPH) AT 100 PSI	RPM
B1V-8200	3	1725
B2V-8200	3	3450
B1Y-8900	7	1725
B1Y-8900	7	3450

STRAINER TYPE	UL Strainer Rating (GPH)* #2 Fuel Oil
V	3
Y	7
T	16

DESIGNATOR	Rotation/Nozzle Location
A	RH/RH
B	RH/LH
C	LH/LH
D	LH/RH

*Max. firing rate not to exceed max. nozzle capacity or strainer rating whichever is Less. A greater firing rate requires a suitable external strainer.

ALL INSTALLATIONS SHOULD BE MADE IN ACCORDANCE WITH LOCAL AND NATIONAL CODES

A SINGLE STAGE • TWO PIPE				
Lift "L" Fig 5	1725 RPM		3450 RPM	
	3/8" OD Tubing	1/2" OD Tubing	3/8" OD Tubing	1/2" OD Tubing
0'	65'	100'	53'	100'
1'	60'	100'	49'	100'
2'	54'	100'	45'	100'
3'	50'	100'	41'	100'
4'	45'	100'	37'	100'
5'	40'	100'	33'	100'
6'	35'	100'	29'	100'
7'	30'	100'	25'	98'
8'	25'	100'	21'	83'
9'	20'	83'	17'	68'
10'	16'	64'	13'	52'

B TWO-STAGE • TWO PIPE				
Lift "L" Fig 5	1725 RPM		3450 RPM	
	3/8" OD Tubing	1/2" OD Tubing	3/8" OD Tubing	1/2" OD Tubing
0'	100'	100'	68'	100'
2'	92'	100'	63'	100'
4'	85'	100'	58'	100'
6'	78'	100'	53'	100'
8'	70'	100'	48'	100'
10'	63'	100'	42'	100'
12'	56'	100'	37'	100'
14'	48'	100'	32'	100'
16'	40'	100'	27'	100'
18'	33'	100'	22'	88'

CAUTION

It is important, when servicing these oil burners, that the gun (drawer) assembly locknut be securely wrench tightened. Wrench tightening will assure proper nozzle centering. The two upper Electrode Support legs must contact the inner surface of the Air Tube firmly. This can be confirmed visually, by viewing the Electrode Support through transformer opening while tightening locknut. The spring located on the lower Electrode Support leg is designed to force the upper locating legs against the Air Tube. Wrench tightening will insure proper positioning.

Improper nozzle centering in relation to Air Cone can result in poor combustion due to flame impingement.

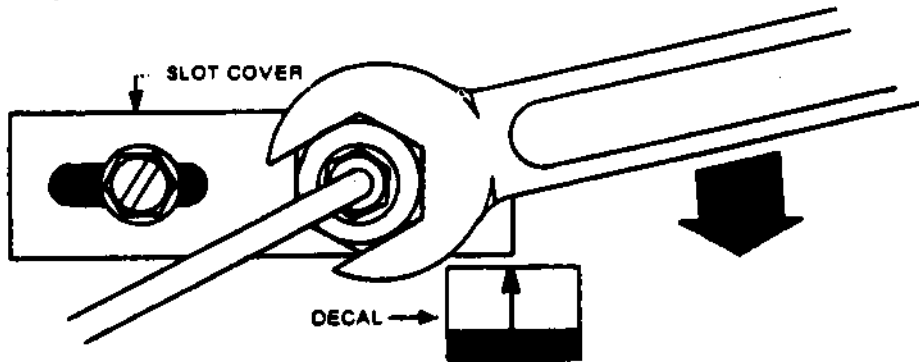

ELECTRODES

Spacing of Electrodes: The electrodes should be spaced $1/8$ inch apart. They should extend $1/8$ inch beyond the end and $1/2$ inch above the center of the nozzle tip as shown in drawing below.

ELECTRODE SETTINGS MSR BURNER

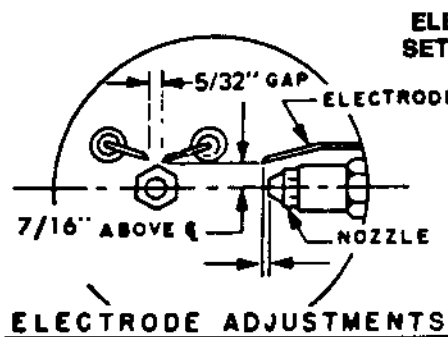
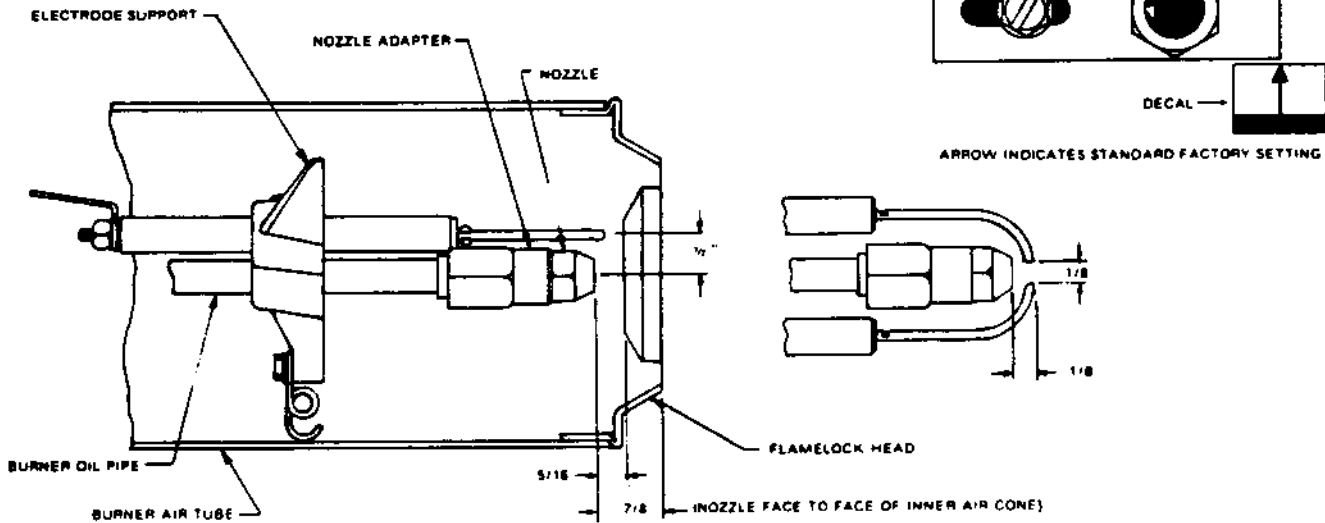

**ELECTRODE POSITION
AHEAD OF NOZZLE.**

MODELS	DIMENSION
F0 thru F31 heads	$1/16$ "

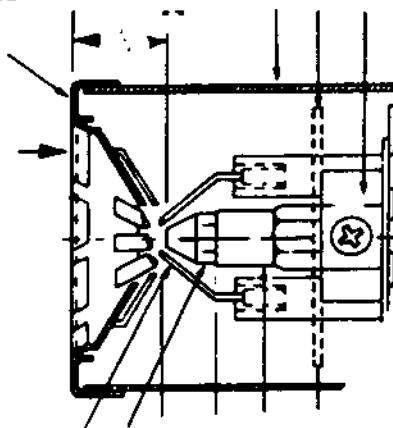

ELECTRODE SETTINGS HS OIL BURNER

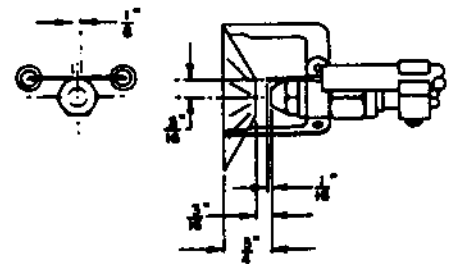

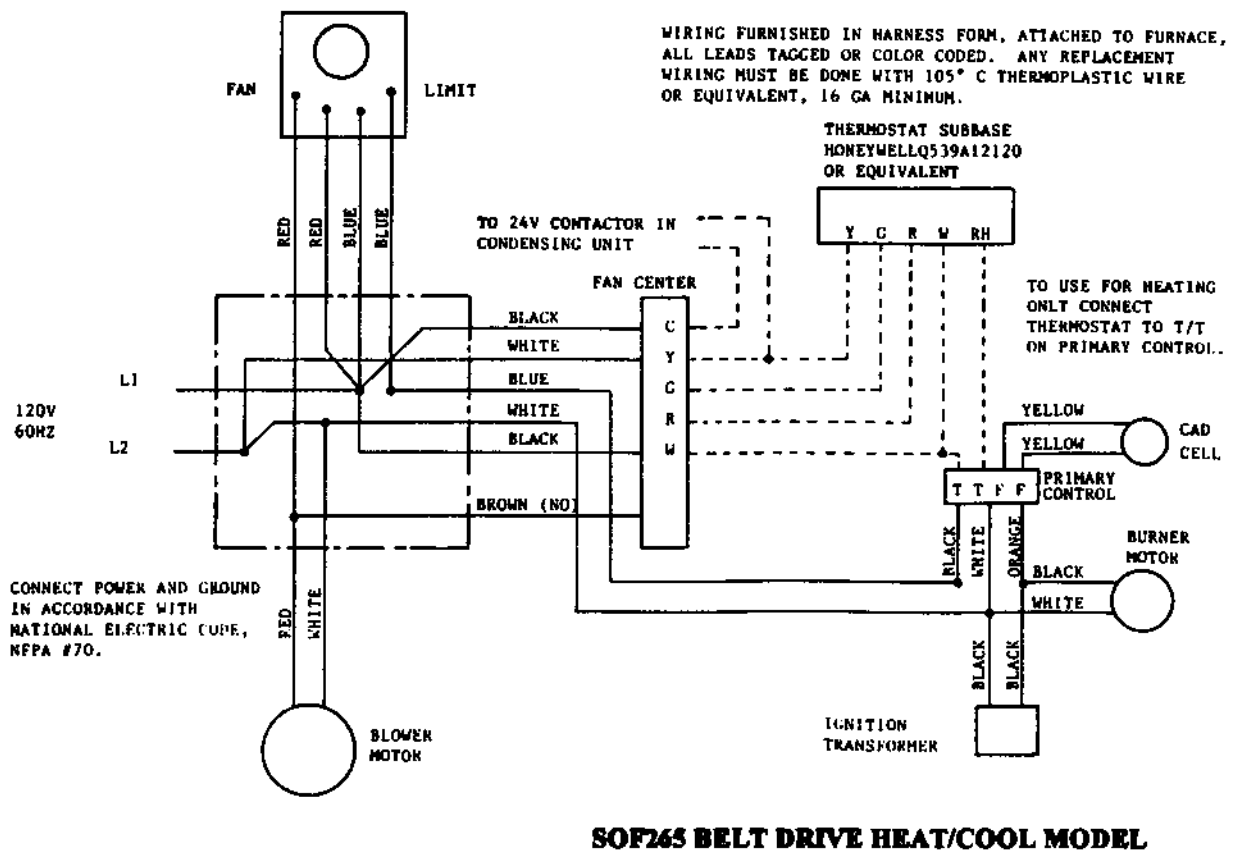
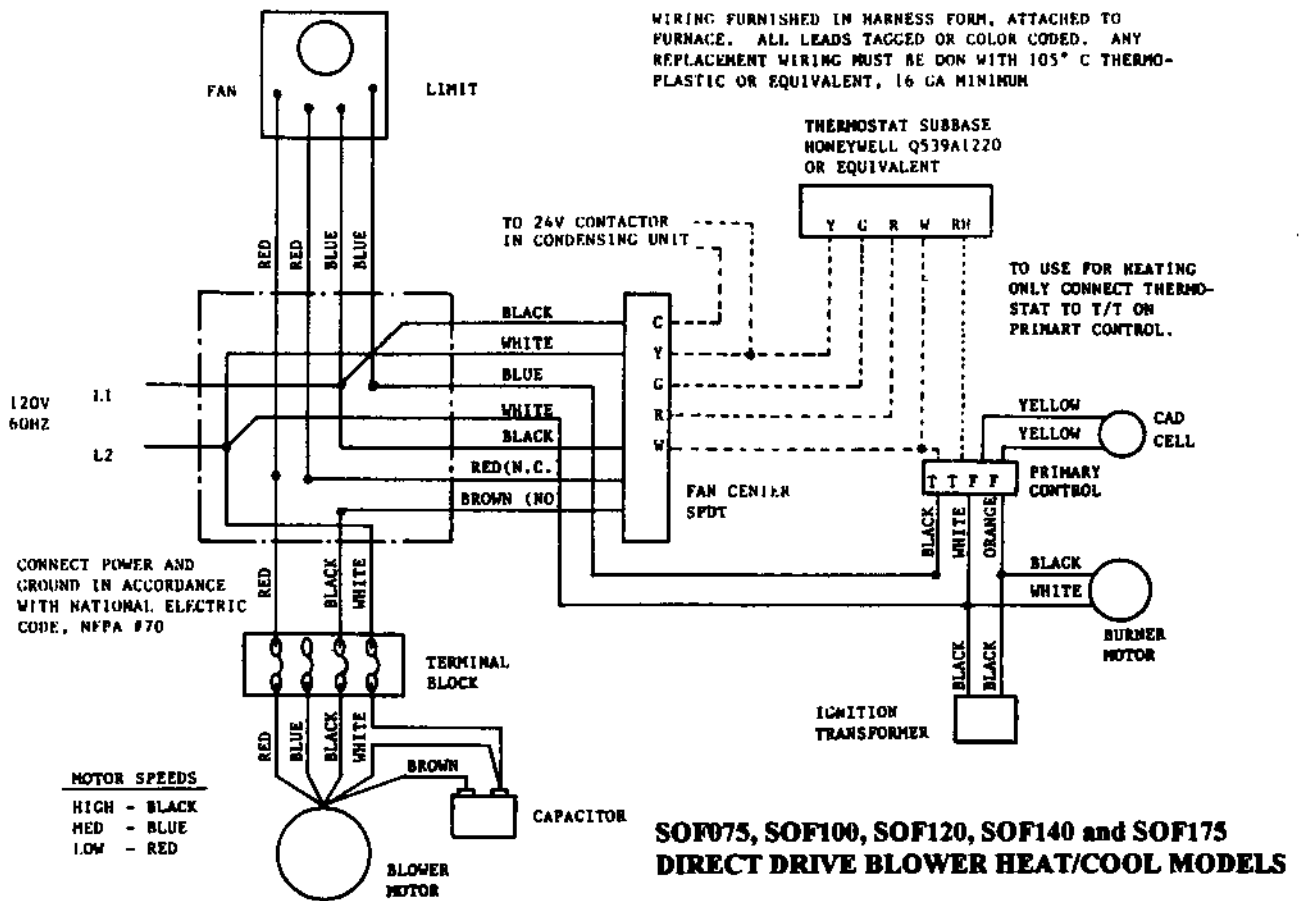
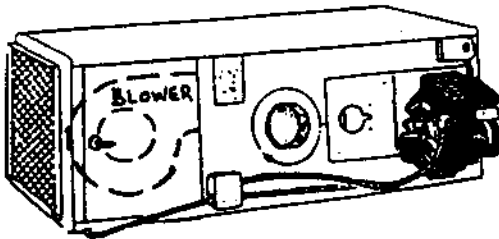

FIGURE G

SOF-SERIES OIL HORIZONTALS

INSTRUCTIONS FOR FIELD CONVERSION FROM RH DISCHARGE TO LH DISCHARGE



TIP UNIT OVER (END OVER END)

ST'D. RH DISCHARGE
FURNACE

LH DISCHARGE
FURNACE

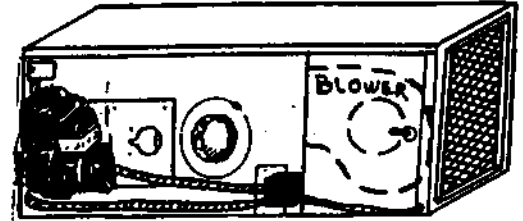

Rotate blower and blower division panel 180°.

Rotate blower and wiring harness as shown.

Punch new holes for fan and limit control.

Install a small piece of metal over old holes left when fan and limit, etc. are relocated.

The fan/limit control must end up the same location from end of furnace and from top edge of furnace after furnace is converted.

LIMIT LOCATIONS AND SETTINGS

LOCATION: Limits to be inserted into the location shown by label on furnace. All limits are 11-1/2" long insertion.

LIMIT SETTINGS:	Model		
	SOF075		200F
	SOF100		200F
	SOF125		180F
	SOF140		180F
	SOF175		180F
	SOF265		180F

BELT ADJUSTMENT OF BELT DRIVEN BLOWER:

Proper belt tension is important and may be checked when blower is not operating and electrical power to unit is turned off. Exert slight pressure on belt with thumb. Belt should depress approximately one inch. Belt tension may be adjusted by turning adjustment screw attached to motor base to raise or lower motor.

CARE OF YOUR FORCED AIR FURNACE

1. Change or clean the air filters when they become dirty. Under normal servicing the permanent filter should be done every (3) three or (4) times a year and the disposable ones replaced at least (3) three times a year. If conditions warrant, then replace more often.
2. Have the furnace serviced at least once a year by a competent service technician. Improper care may result in poor efficiency or possible soot fire.
3. Clean the furnace jacket occasionally with a soft cloth and mild soap solution. Also remove blower access door. Use a vacuum cleaner and soft cloth to clean both the blower assembly and compartment.
4. Complete and return warranty registration card.