INSTALLATION INSTRUCTIONS

MODELS
ERVR-A3B
ERVR-C3B

RETROFIT ENERGY RECOVERY VENTILATOR

**For Use with Bard 2-1/2 And 3 Ton Wall Mount
Air Conditioners and Heat Pumps, 2 Thru 5
Ton "P" Series Air Conditioners and Heat
Pumps, and "WAG" Series Wall Mount Gas
Electric Units**



Bard Manufacturing Company
Bryan, Ohio 43506

*Since 1914...Moving ahead, just as
planned.*

Manual : 2100-309A
Rev.: 2100-309
File: Volume III Tab 19
Date: 10-31-97

© Copyright 1997

Contents

Electrical Specifications	1
General Description	1
Unit Compatibility	1
Performance and Application Data	2
General Information	3
Unpacking	3
Basic Installation (Field Installation)	3
WA, WH Series Installation Steps	4
"P" Series Installation Instructions – 3 1/2 thru 5 Ton Cabinet (Old Style)	7
"P" Series Installation Instructions – 3 1/2 thru 5 Ton Cabinet (New Style)	12
"P" Series Installation Instructions – 2 thru 3 Ton Cabinet	17
WAG Series Installation Instructions	21
Ventilator Checkout	25
Control Options	25
Ventilation Air Flow	25
Servicing the ERVR System	25
Energy Transfer Wheel	25

Figures

Figure 1	4
Figure 2	5
Figure 3	6
Figure 4	6
Figure 5	7
Figure 6	8
Figure 7	9
Figure 8	10
Figure 9	11
Figure 10	12
Figure 11	13
Figure 12	14
Figure 13	15
Figure 14	16
Figure 15	17
Figure 16	18
Figure 17	19
Figure 18	20
Figure 19	21
Figure 20	22
Figure 21	23
Figure 22	24
Figure 23	26
Figure 24	27

Tables

Table 1	1
Table 2	1
Table 3	25

ELECTRICAL SPECIFICATIONS

TABLE 1

Model	Voltage	Amps	Control Voltage
ERVR-A3B	230/208 1 PH or 3 PH	2.2	24V
ERVR-C3B	460 3 PH	1.2	24V

NOTE: The power supply and wiring to an existing unit must be reviewed for adequacy to handle the additional amperage of the ERVR in accordance with all local and national electrical codes.

GENERAL DESCRIPTION

The Bard Energy recovery ventilator was designed to provide energy efficient, cost effective ventilation to meet I.A.Q. (Indoor Air Quality) requirements while still maintaining good indoor comfort and humidity control for a variety of applications such as schools, classrooms,

lounges, conference rooms, beauty salons and others. It provides a constant supply of fresh air for control of airborne pollutants including CO₂, smoke, radon, formaldehyde, excess moisture, virus and bacteria.

The ventilator incorporates patented rotary heat exchanger technology to remove both heat and moisture.

It is designed as a single package which can be easily field installed for new installations or retrofit to the old Bard WA and WH series wall mounted units. The package consists of a unique rotary Energy Recovery Cassette that can be easily removed for cleaning or maintenance. The ERVR has two 13 inch diameter heat transfer wheels. The heat transfer wheels use a permanently bonded dry desiccant coating for total heat recovery.

Ventilation is accomplished with (2) blower/motor assemblies each consisting of a drive motor and dual blowers for maximum ventilation at low sound levels. Air is exhausted at the same rate that fresh air is brought into the structure thus not pressuring the building. The rotating energy wheels provide the heat transfer effectively during both summer and winter conditions. The ERVR provides required ventilation to meet the requirements of ASHRAE 62-1989 standard.

NOTE: During operation below 4 degrees F outdoor temperature, freezing of moisture in the heat transfer wheel can occur. Consult the factory if this possibility exists.

UNIT COMPATIBILITY CHART

The ERVR can be retrofitted to the following units with additional panel kit as indicated.

TABLE 2

MODEL	REQUIRED PANEL KIT	INSTALLATION STEPS
30WA, 36WA, 30 WH, 36WH	None	WA, WH Series Page 4
P24, P25, P30, P36, P1024, P1030, P1036, P1124, P1130, P1136 PH24, PH25, PH31, PH36, PH1124, PH1130, PH1136 With RHE36 Roof Hood	8620-107	"P" Series 2 3 Ton Page17
P48, P60, P72, P1045, P1142A1, PH42, PH48, PH60 PH1142 With RHE60 Roof Hood	8620-107	"P" Series 3-1/2 5 Ton Old Style Page 7
WAG30, WAG36, WAG40	8620-108	"WAG" Series Page21
PH1421, PH1060, PH1048, P1148, P1142A2, P1060 With RHE60 Roof Hood	8620-109	"P" Series 3-1/2 5 Ton New Style Page12

PERFORMANCE AND APPLICATION DATA — ERVR-A3B and ERVR-C3B

**Summer Cooling Performance
(Indoor Design Conditions 75° DB / 62° WB)**

Ambient O.D.	VENTILATION RATE 400 CFM 63% Efficiency						VENTILATION RATE 325 CFM 64% Efficiency						VENTILATION RATE 250 CFM 65% Efficiency						
	DB/WB F	VLT	VLS	VLL	HRT	TRS	HRL	VLT	VLS	VLL	HRT	HRS	HRL	VLT	VLS	VLL	HRT	HRS	HRL
105	75	19080		6120	12020		3855	15502		4972	9921		3182	11925		3825	7751		2486
	70	12960	12960	0	8164	8164	0	10530	10530	0	6739	6739	0	8100	8100	0	5265	5265	0
	65	12960		0	8164		0	10530		0	6739		0	8100		0	5265		0
100	80	28080		17280	17690		10886	22815		14040	14601		8985	17550		10800	11407		7019
	75	19080		8280	12020		5216	15502		6727	9921		4305	11925		5175	7751		3363
	70	10980	10800	180	6717	6804	113	8921	8775	146	5709	5616	93	6862	6750	112	4460	4387	73
	65	10800		0	6804		0	8775		0	5616		0	6750		0	4387		0
	60	10800		0	6804		0	8775		0	5616		0	6750		0	4387		0
95	80	28080		19440	17690		12247	22815		15795	14601		10108	17550		12150	11407		7897
	75	19080		10440	12020		6577	15502		8482	9921		5428	11925		6525	7751		4241
	70	10980	8640	2340	6917	5443	1474	8921	7020	1901	5709	4492	1216	6862	5400	1462	4460	3510	950
	65	8640		0	5443		0	7020		0	4492		0	5400		0	3510		0
	60	8640		0	5443		0	7020		0	4492		0	5400		0	3510		0
90	80	28080		21600	17690		13608	22815		17550	14601		11232	17550		13500	11407		8774
	75	19080		12600	12020		7938	15502		10237	9921		6552	11925		7875	7751		5118
	70	10980	6480	4500	6917	4082	2835	8921	5265	3656	5709	3369	2340	6862	4050	2812	4460	2632	1828
	65	6480		0	4082		0	5265		0	3369		0	4050		0	2632		0
	60	6480		0	4082		0	5265		0	3369		0	4050		0	2632		0
85	80	28080		23760	17690		14968	22815		19305	14601		12355	17550		14850	11407		9652
	75	19080		14760	12020		9298	15502		11992	9921		7675	11925		9225	7751		5996
	70	10980	4320	6660	6917	2721	4195	8921	3510	5411	5709	2246	3463	6862	2700	4162	4460	1755	2705
	65	4320		0	2721		0	3510		0	2246		0	2700		0	1755		0
	60	4320		0	2721		0	3510		0	2246		0	2700		0	1755		0
80	75	19080		16920	12020		10659	15502		13747	9921		8798	11925		10575	7751		6873
	70	10980		8820	6917		5556	8921		7166	5709		4586	6862		5512	4460		3583
	65	3780	2160	1620	2381	1360	1020	3071	1755	1316	1965	1123	842	2362	1350	1012	1535	877	658
	60	2160		0	1360		0	1755		0	1123		0	1350		0	877		0
75	70	10980		10980	6917		6917	8921		8921	5709		5709	6862		6862	4460		4460
	65	3780	000	3780	2381	000	2380	3071	000	3071	1965	000	1965	2362	000	2362	1535	000	1535
	60	0		0	0		0	0		0	0		0	0		0	0		0

**Winter Heating Performance
(Indoor Design Conditions 70° F DB)**

Ambient O.D.	VENTILATION RATE					
	400 CFM 75% Eff		325 CFM 76% Eff		250 CFM 77% Eff	
DB F	WVL	WHR	WVL	WHR	WVL	WHR
65	2160	1620	1755	1333	1350	1039
60	4320	3240	3510	2667	2700	2079
55	6480	4860	5265	4001	4050	3118
50	8640	6480	7020	5335	5400	4158
45	10800	8100	8775	6669	6750	5197
40	12960	9720	10530	8002	8100	6237
35	15120	11340	12285	9336	9450	7276
30	17280	12960	14040	10670	10800	8316
25	19440	14580	15795	12004	12150	9355
20	21600	16200	17550	13338	13500	10395
15	23760	17820	19305	14671	14850	11434

LEGEND:

- VLT = Ventilation Load – Total
- VLS = Ventilation Load – Sensible
- VLL = Ventilation Load – Latent
- HRT = Heat Recover – Total
- HRS = Heat Recovery – Sensible
- HRL = Heat Recovery – Latent
- WVL = Winter Ventilation Load
- WHR = Winter Heat Recovery

GENERAL INFORMATION

The ventilator should only be installed by a trained heating and air conditioning technician. These instructions serve as a guide to the technician installing the ventilator package. They are not intended as a step by step procedure with which the mechanically inclined owner can install the package.

The ventilator housing is shipped in one carton which contains the following:

1. Energy Recovery Ventilator
2. Service Door and Upper Door
3. Installation Instructions

For retrofit to "P" series or "WAG" series units see Table 2 for panel kit required.

UNPACKING

Upon receipt of the equipment, be sure to compare the model number found on the shipping label with the accessory identification information on the ordering and shipping document to verify that the correct accessory has been shipped.

Inspect the carton housing of each ventilator as it is received, and before signing the freight bill verify that all items have been received and that there is no visible damage. Note any shortages or damage on all copies of the freight bill. The receiving party must contact the last carrier immediately, preferably in writing, requesting inspection by the carrier's agent. Concealed damage not discovered until after loading must be reported to the carrier within 15 days of its receipt.

BASIC INSTALLATION (Field Installation)

Unpack the ventilator assembly which includes the integral ventilator with attached electrical harnesses and miscellaneous hardware.



WARNING

Open and lock unit disconnect switch before installing this accessory to prevent injury or death due to electrical shock or contact with moving parts. Turn thermostat to OFF.



CAUTION

Be sure the correct model and voltage Energy Recovery Ventilator is used with the correct air conditioner or heat pump to insure correct voltage compatibility.

WA, WH SERIES INSTALLATION STEPS

1. Remove the existing exterior blower access and service access panels on the Bard Wall Mount™ units and discard. (See Figure 1.)
2. Install wire harnesses (in hardware bag) from control panel to above blower partition. See wiring diagram for wiring information. (See Figures 2 and 23 or 24.)
3. Install new lower access door supplied with ERVR. (See Figure 3.)
4. Remove top from ERVR and install ERVR above lower access door with six self-drilling screws provided. (See Figure 3.)
5. Plug wiring harnesses into back of ERVR. (See Figure 4.) Plug mating half of connector from ERVR into back of ERVR.
6. Install upper panel above ERVR. (See Figure 3.)
7. Go to Ventilator Checkout on Page 25.

FIGURE 1

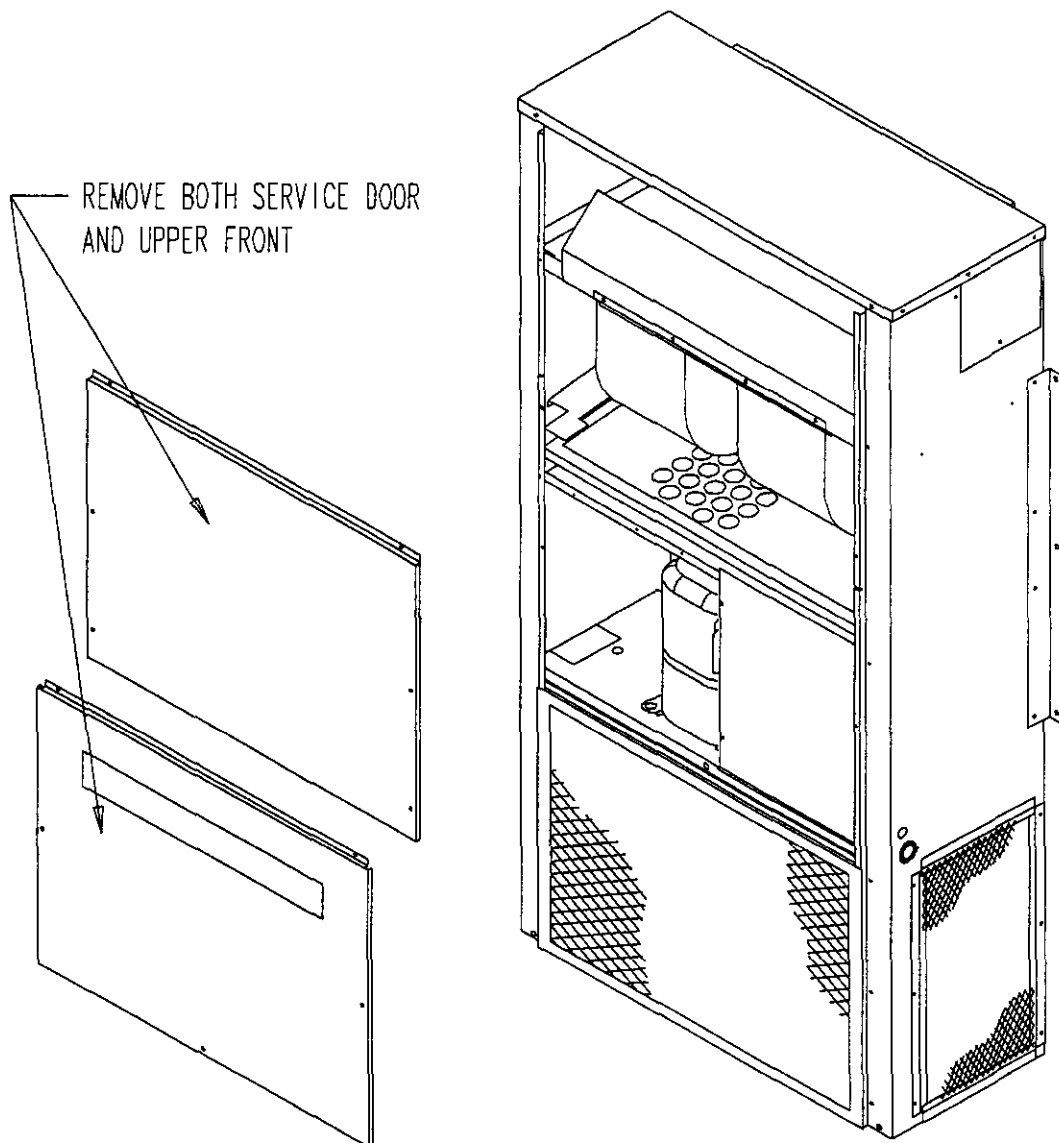

MIS-667

FIGURE 2

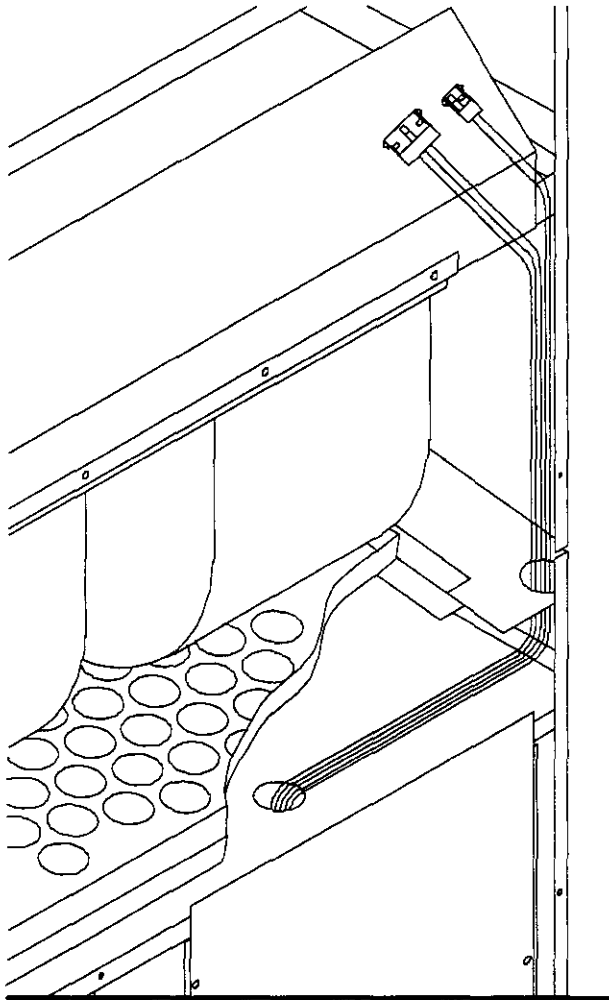

ROUTE WIRES FROM QUICK-LOCK
PLUGS DOWN THROUGH FILTER BRACKET
AND THROUGH HOLE IN COMPRESSOR BASE
INTO CONTROL PANEL

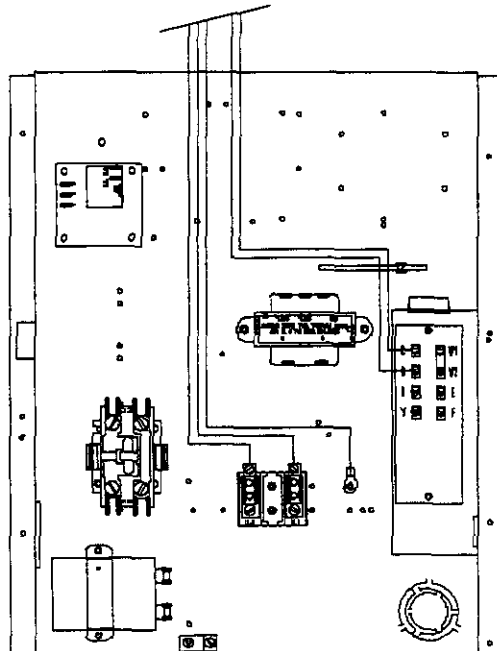

REFER TO WIRING DIAGRAM
FOR CORRECT WIRE PLACEMENT

MIS-668

FIGURE 3

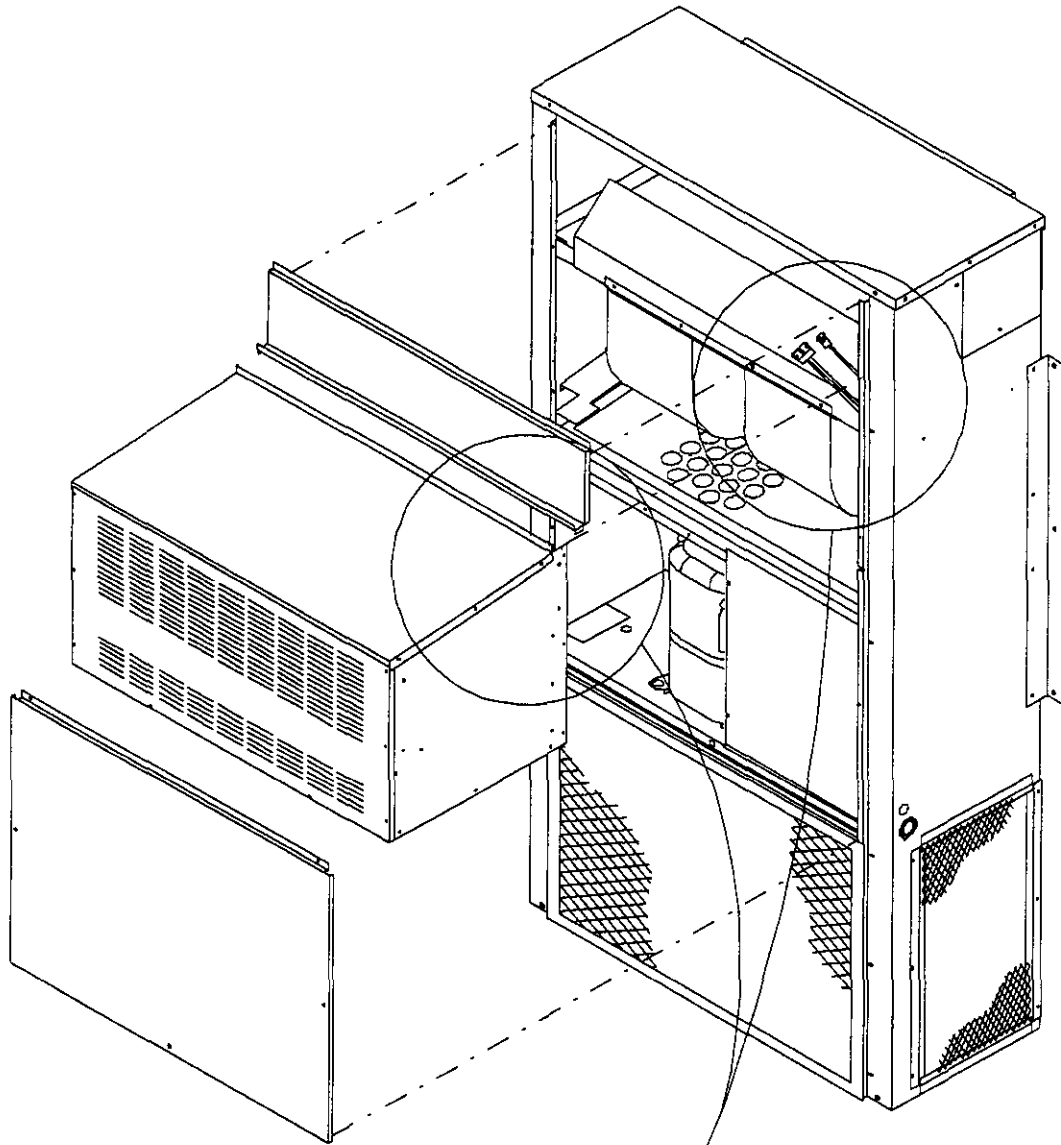
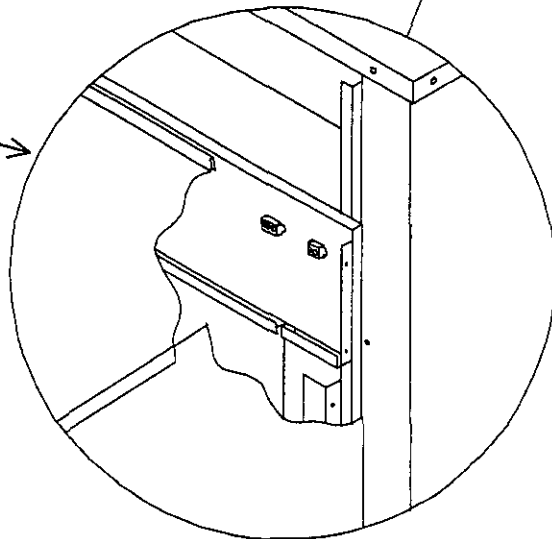

FIGURE 4 - INSET



MIS-669

"P" SERIES INSTALLATION STEPS – 3-1/2 THRU 5 TON CABINET (OLD STYLE)

1. Lock fresh air damper blade closed. Remove plastic clip and reposition as shown in Figure 5.
2. Remove blank off plate or economizer and control panel access door and discard. (See Figure 6.)
3. Install small panel on left side of opening from 8620-107 kit. Install 1-3/4 inch bushing from hardware kit in small panel. Install Wiring harnesses per wiring diagram. (See Figures 7 and 23 or 24.)
4. Install lower blank off plate on RHE60 hood. (Figure 7.)
5. Attach mounting angles to ERVR. (See Figure 8.)
6. Install wiring harness caps into back of ERVR. Install right side screws in ERVR using pre-punched holes in small panel installed in Step 3. (See Figure 8.)
7. Level ERVR and screw left side fast using self drilling screws provided in hardware kit.
8. Remove top of ERVR and plug ERVR into wiring harness. (See Figure 9)
9. Install "J" channel as shown in Figure 9.
10. Caulk back of offset angle and secure to RHE60. (See Figure 9.)
11. Go to Ventilator Checkout on Page 25.

FIGURE 5

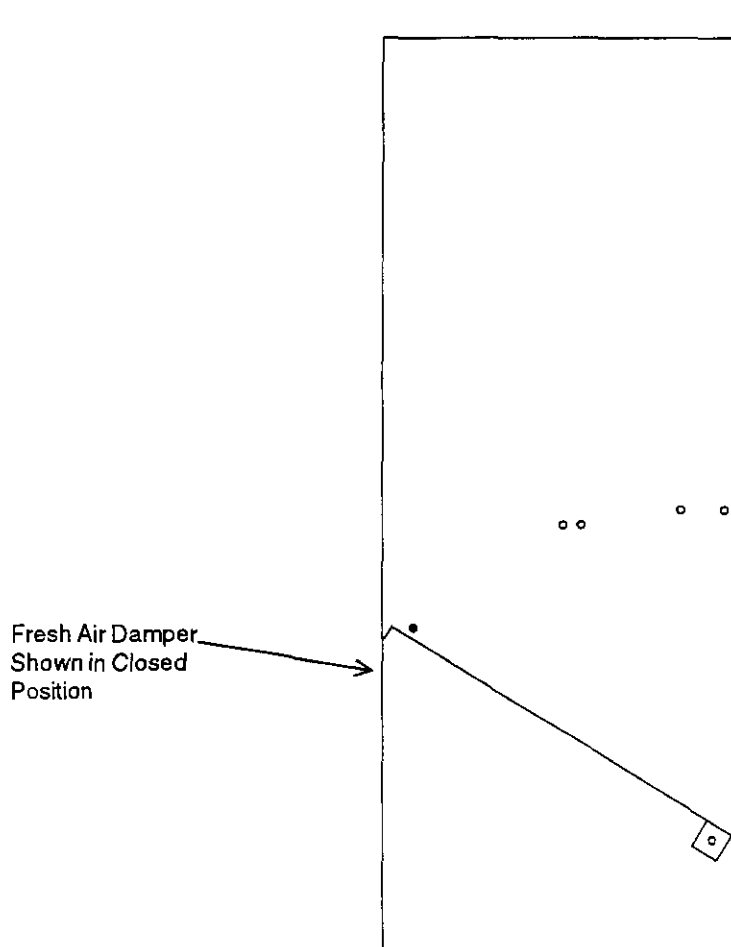

MIS-237

FIGURE 6

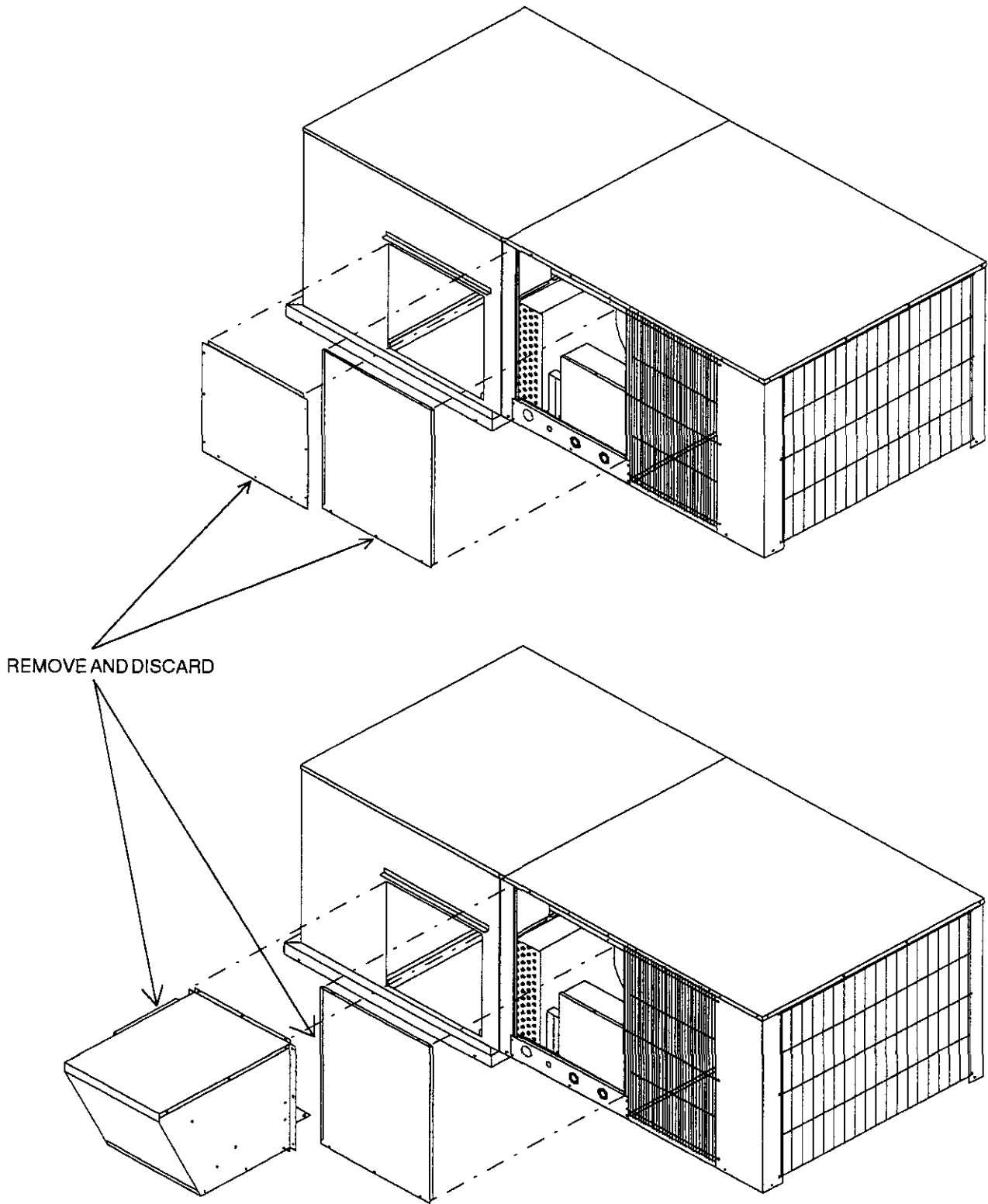

FIGURE 7

MIS-674

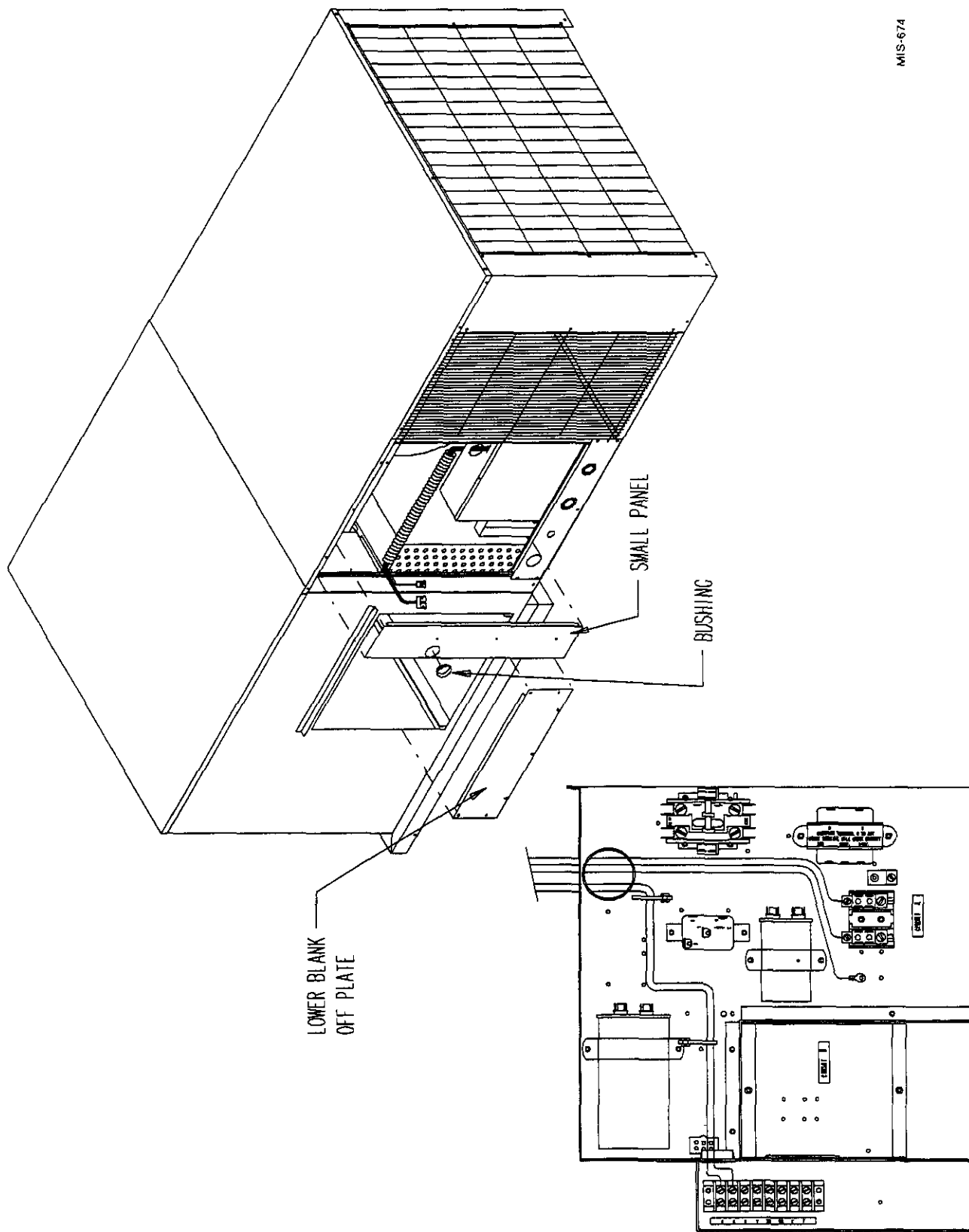
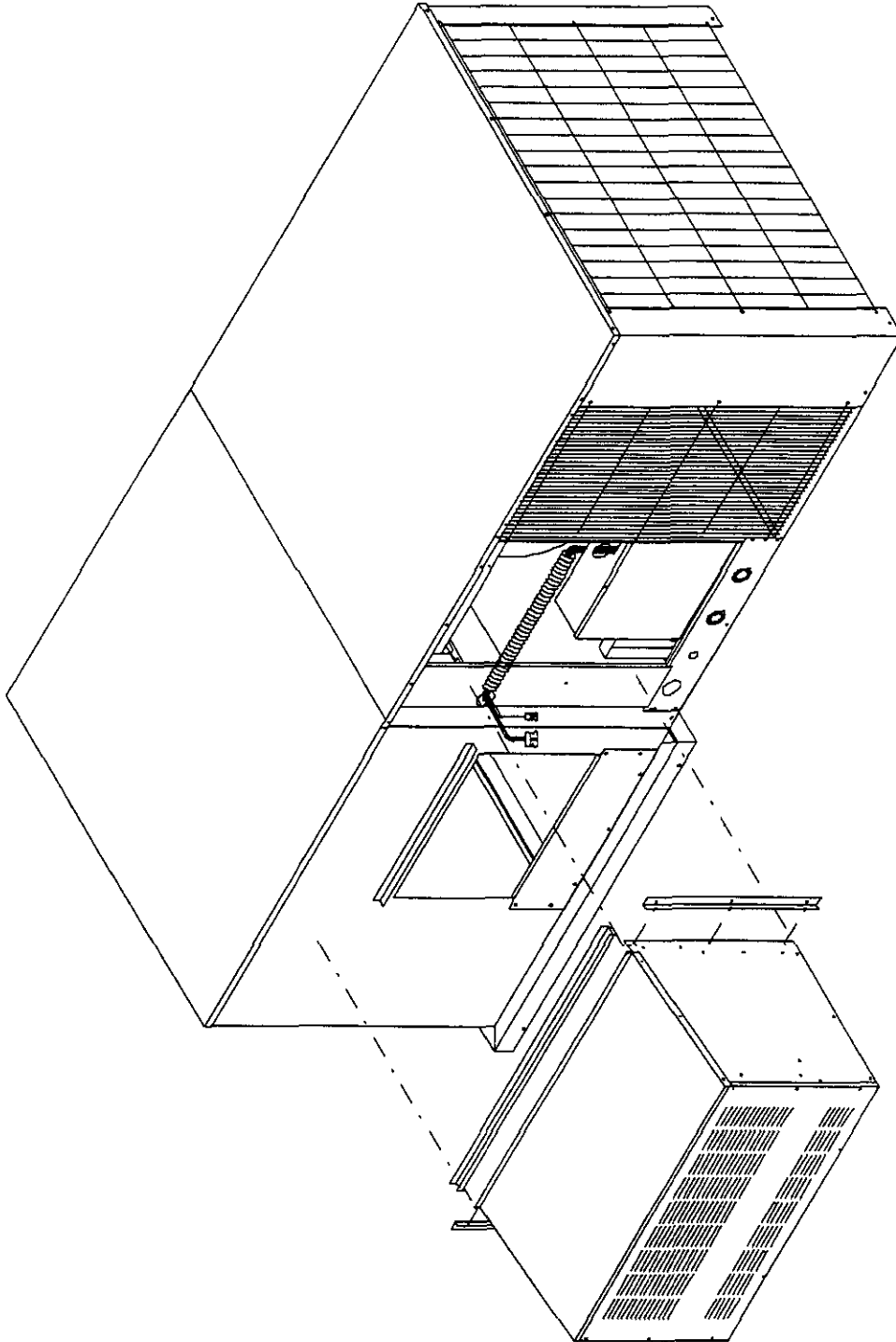

FIGURE 8



MIS-675

FIGURE 9

MIS-676

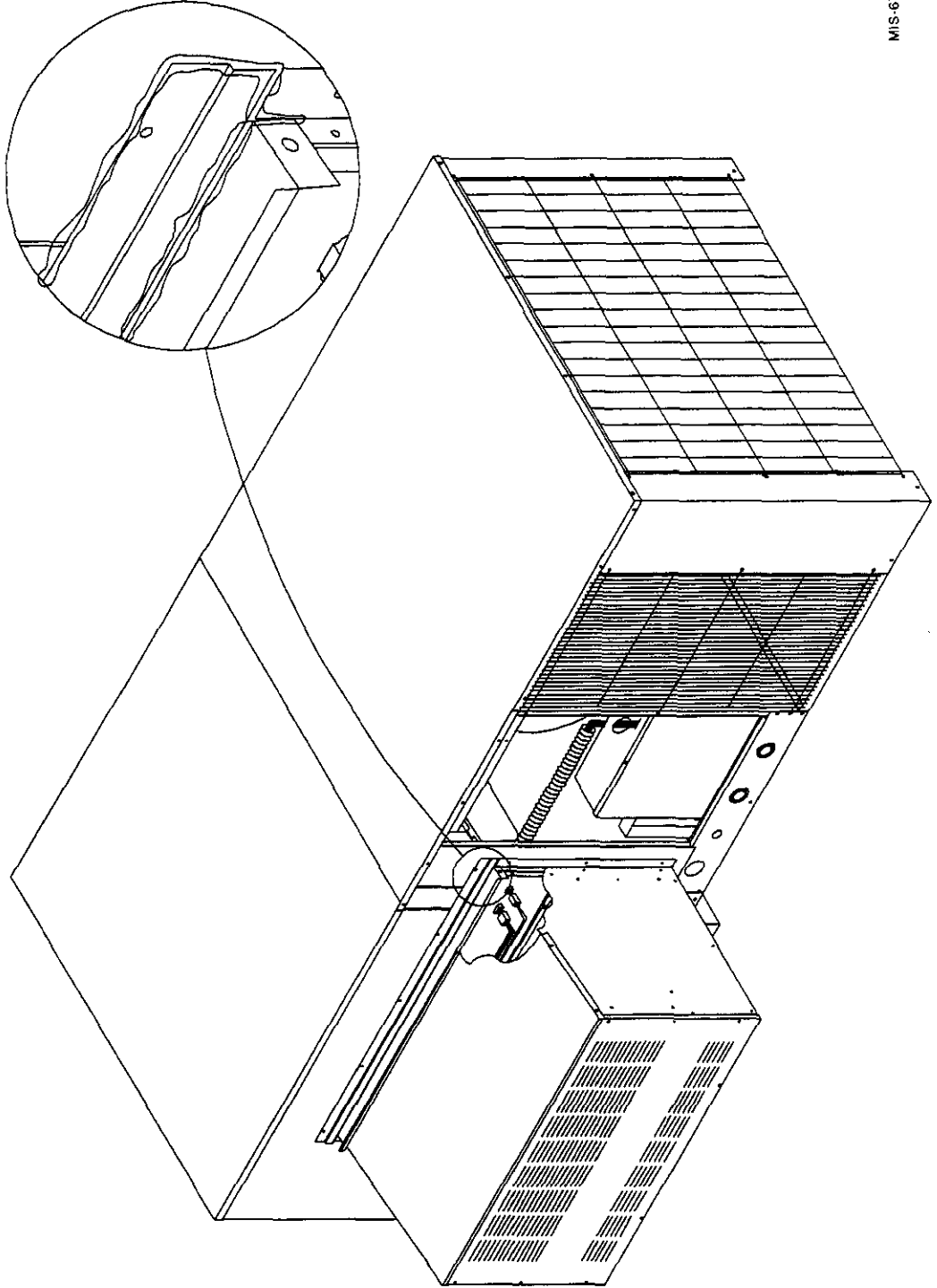

"P" SERIES INSTALLATION STEPS – 3-1/2 THRU 5 TON CABINET (NEW STYLE)

1. Lock fresh air damper blade closed. Remove plastic clip and reposition as shown in Figure 5.
2. Remove blank off plate or economizer from RHE60 and discard. Remove left and right side panels. (See Figure 10.)
3. Drill 1-3/4 inch hole and three 1/8 inch holes in the left front corner of the unit per Figure 11.
4. Insert 1-3/4 inch bushing from hardware kit. Install wiring harness. (See Figures 12 and 23 or 24.)
5. Install BOP supplied with 8620-109 kit.
6. Install mounting angles on ERVR using pre-punched holes. (See Figure 13.)
7. Install wiring harness caps into back of ERVR.
8. Secure right side to holes drilled in Step 3.
9. Level ERVR and secure left side to RHE60 with self drilling screws provided. (See Figure 14.)
10. Remove top of ERVR and plug ERVR into wiring harness. (See Figure 14.)
11. Attach "J" channel as shown in Figure 14.
12. Caulk back of offset angle and secure to RHE60. (See Figure 14.)
13. Go to Ventilator Checkout on Page 25.

FIGURE 10

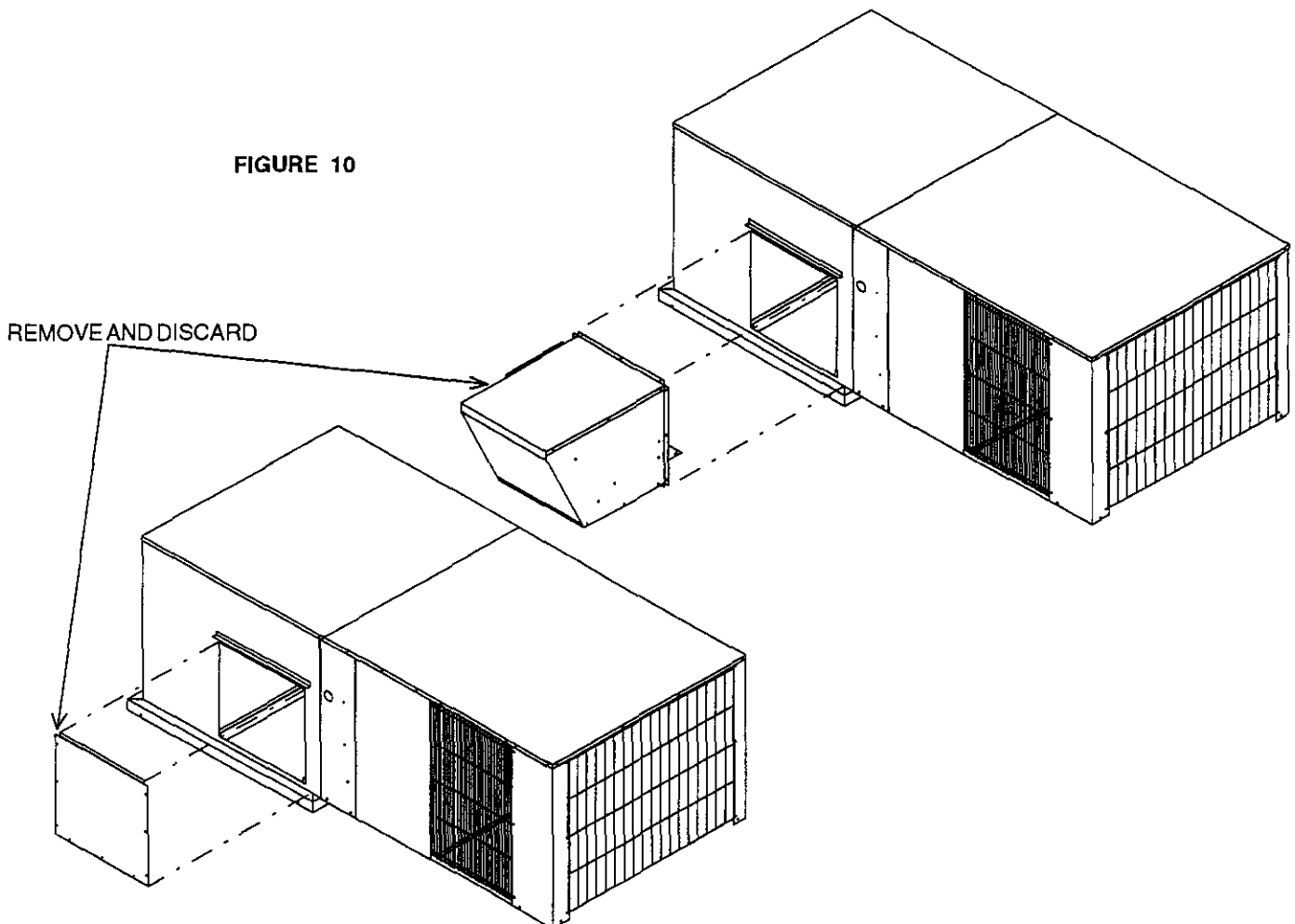

MIS-680

FIGURE 11

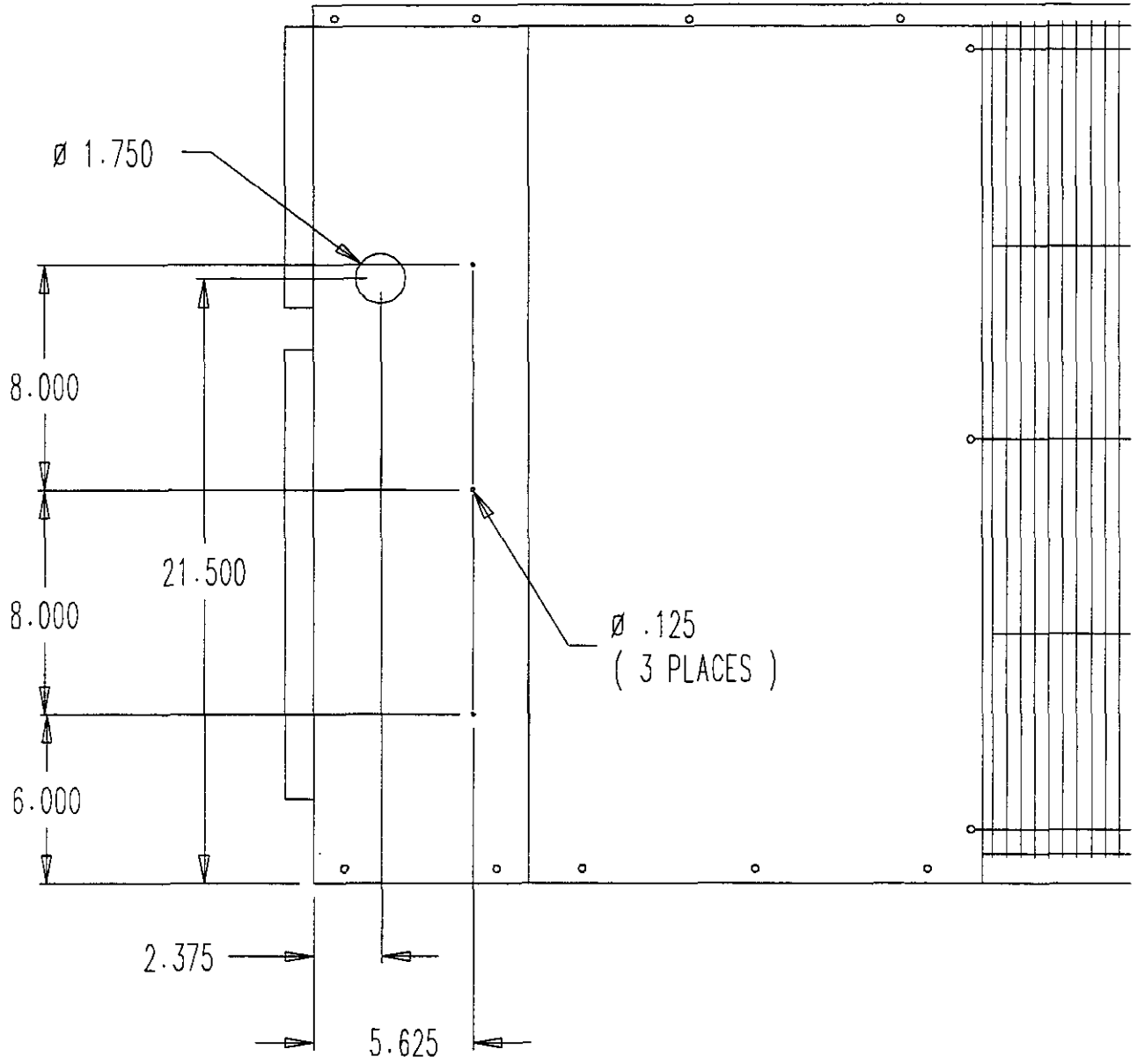

MIS-679

FIGURE 12

MIS-681

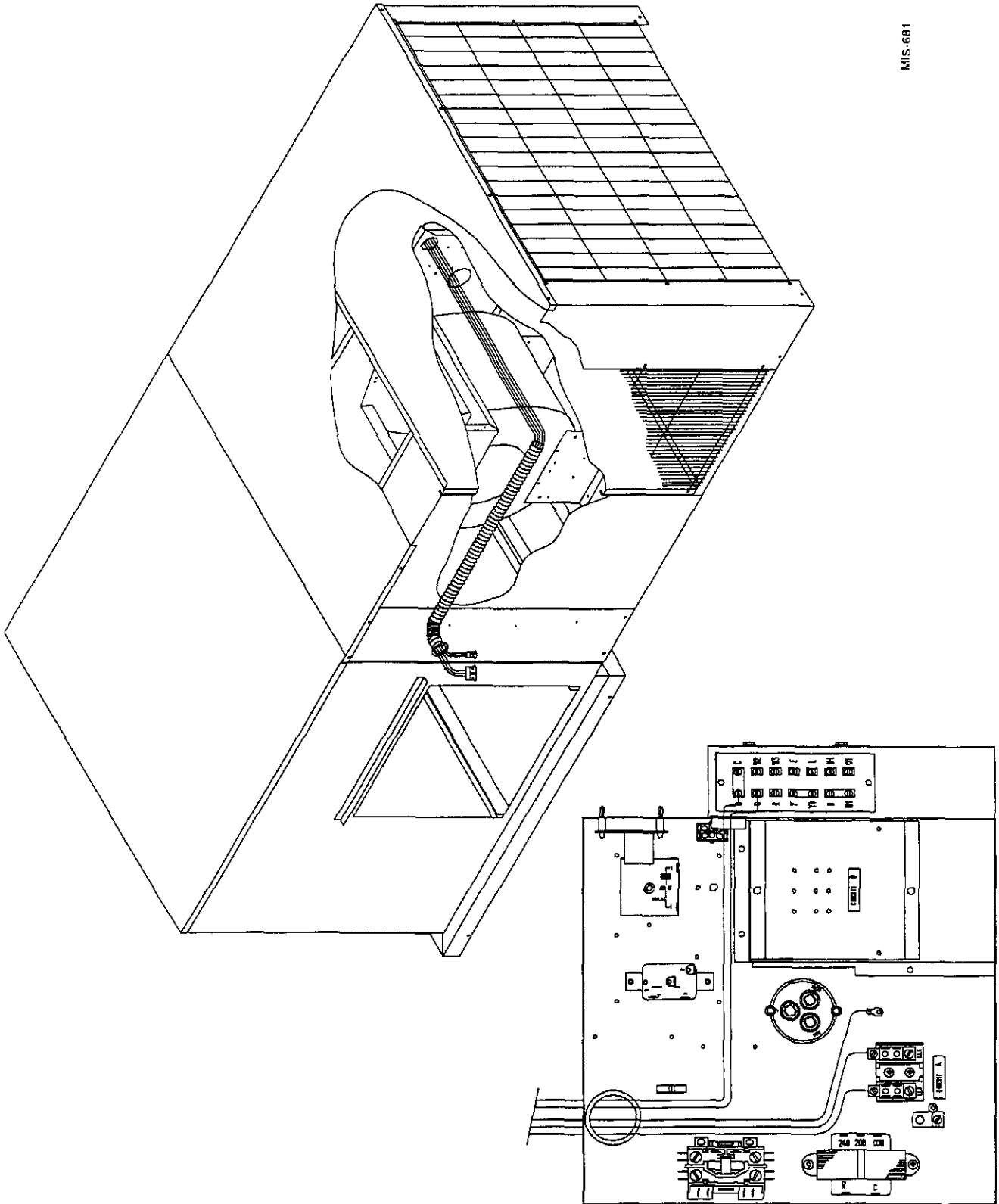
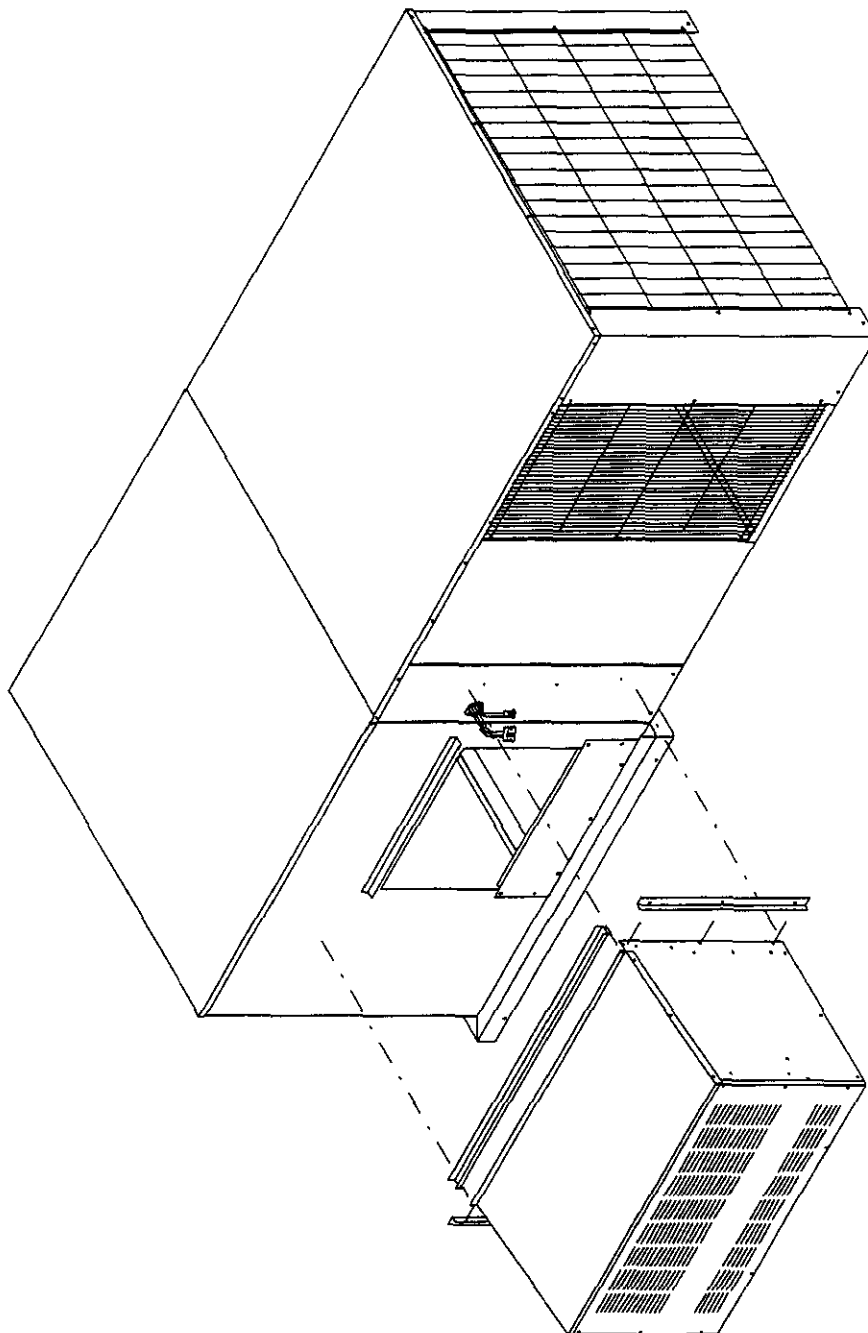
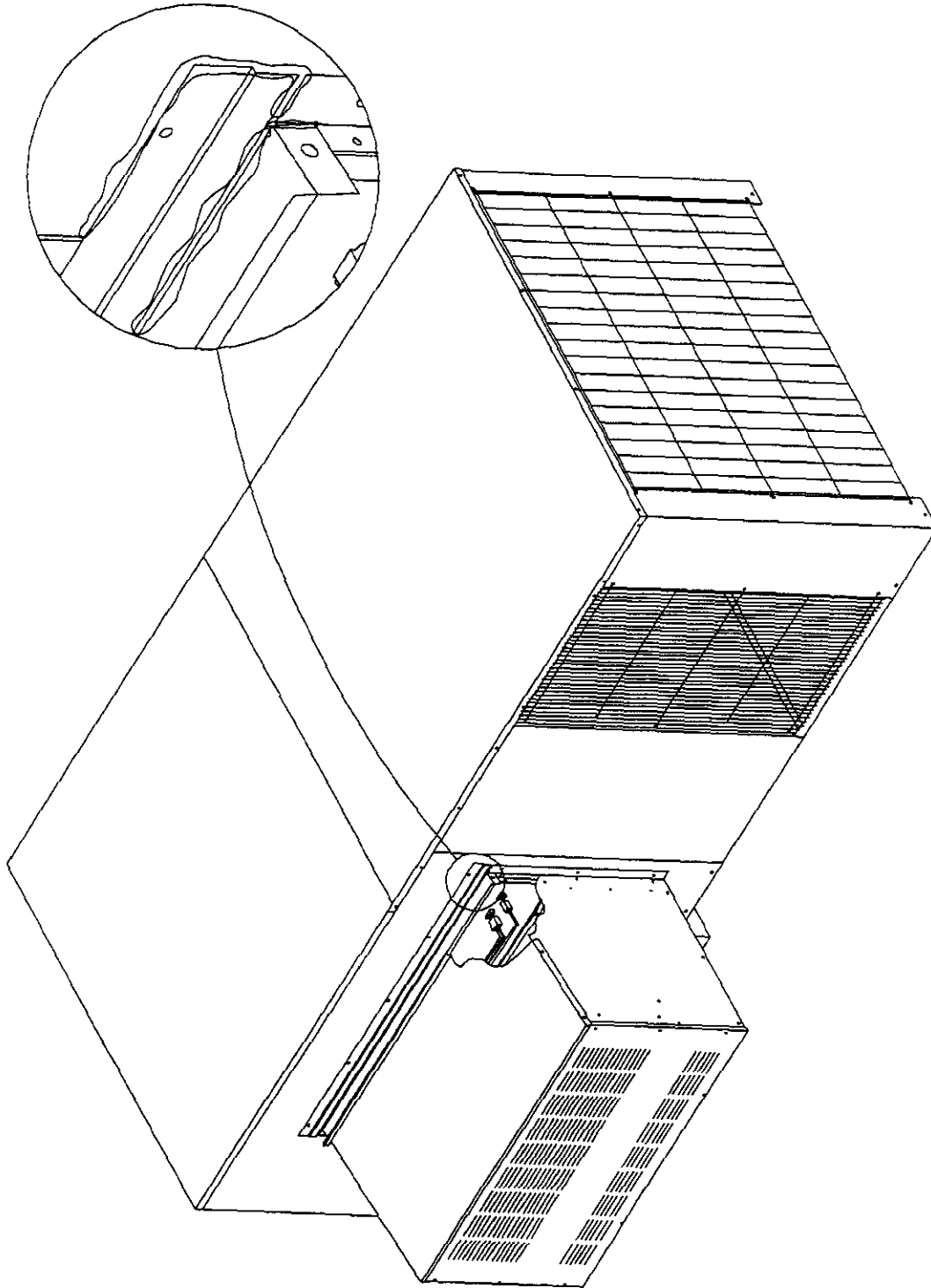

FIGURE 13



MIS-682

FIGURE 14



MIS-683

"P" SERIES INSTALLATION STEPS – 2 AND 3 TON CABINET

1. Lock fresh air damper blade closed. Remove plastic clip and reposition as shown in Figure 5.
2. Remove blank off plate or economizer and control panel access door and discard. (See Figure 15.)
3. Install small panel on right side of opening from 8620-107 kit. Install 1-3/4 inch bushing from hardware kit in small panel. Install wiring harnesses per wiring diagram. (See Figures 16 and 23 or 24.)
4. Install "J" channel and lower blank off plate on RHE36 hood. (See Figure 17.)
5. Attach mounting angles to ERVR. (See Figure 17.)
6. Install wiring harness caps into back of ERVR.
7. Secure left side of ERVR to RHE36 using pre-punched holes in small panel installed in Step 3.
8. Level ERVR and screw right side fast using self drilling screws provided in hardware kit. (See Figure 18.)
9. Remove ERVR top and plug wiring harness into back of ERVR.
10. Caulk between top and "J" channel. (See Figure 18.)
11. Go to Ventilator Checkout on Page 25.

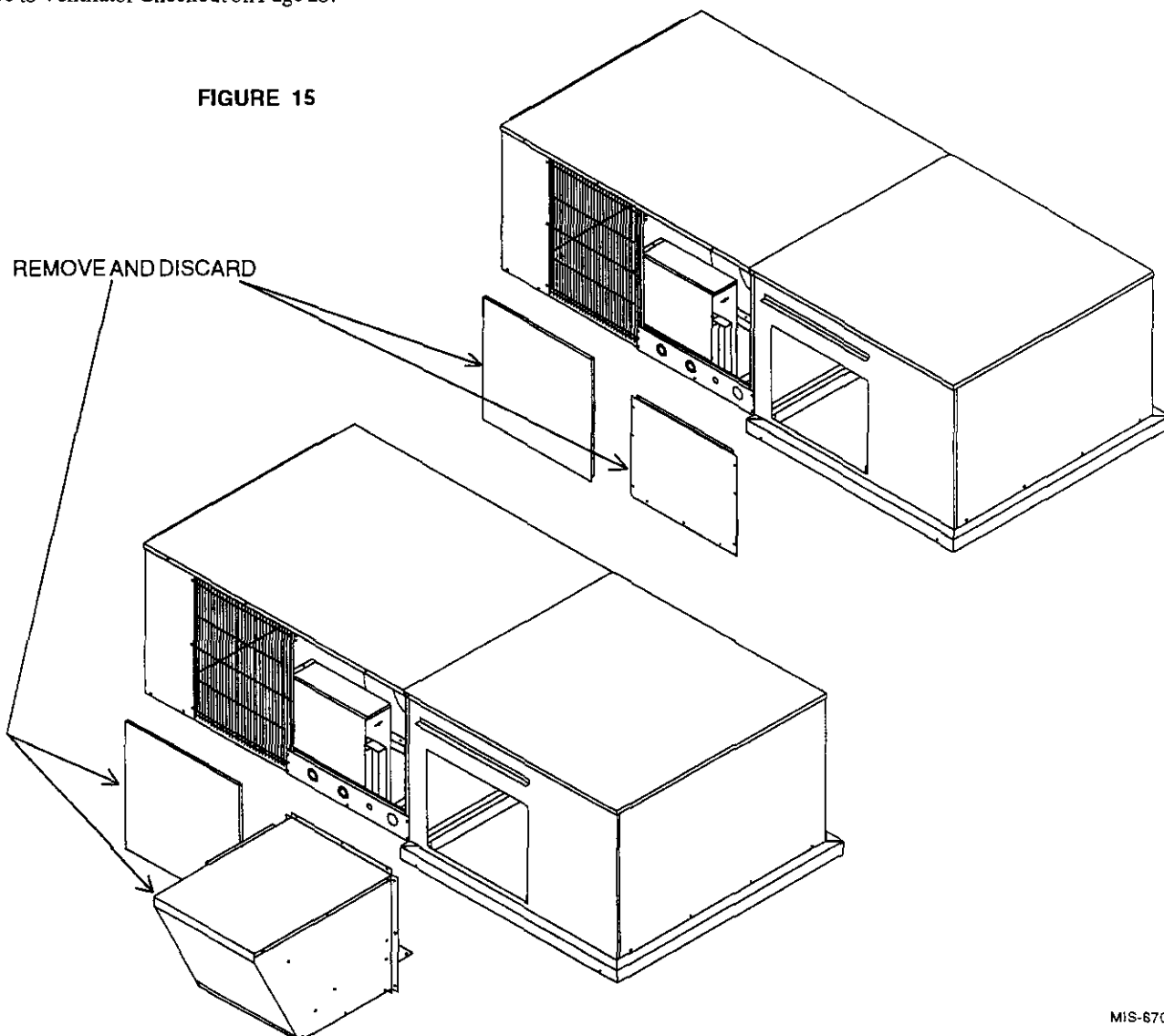

MIS-670

FIGURE 16

MIS-671

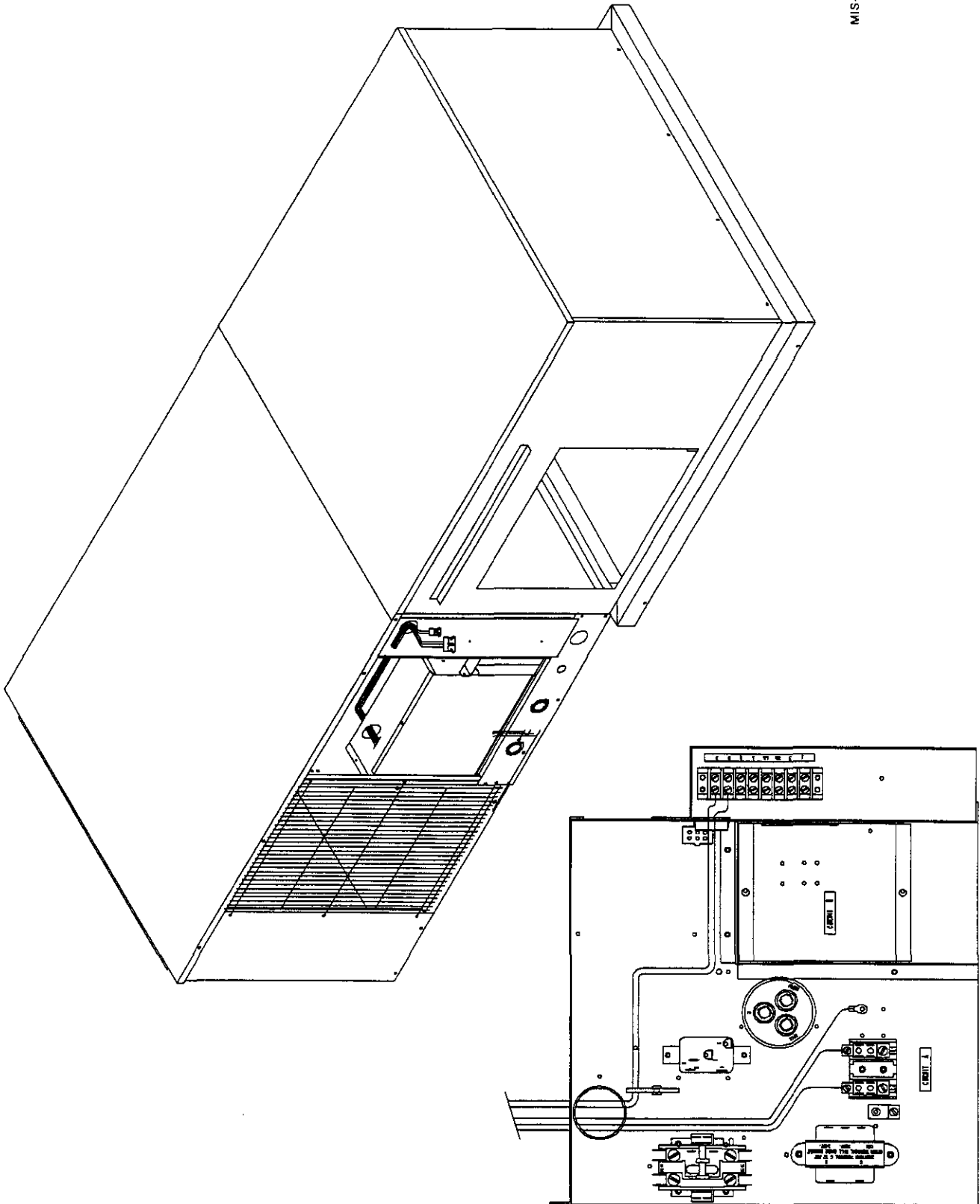
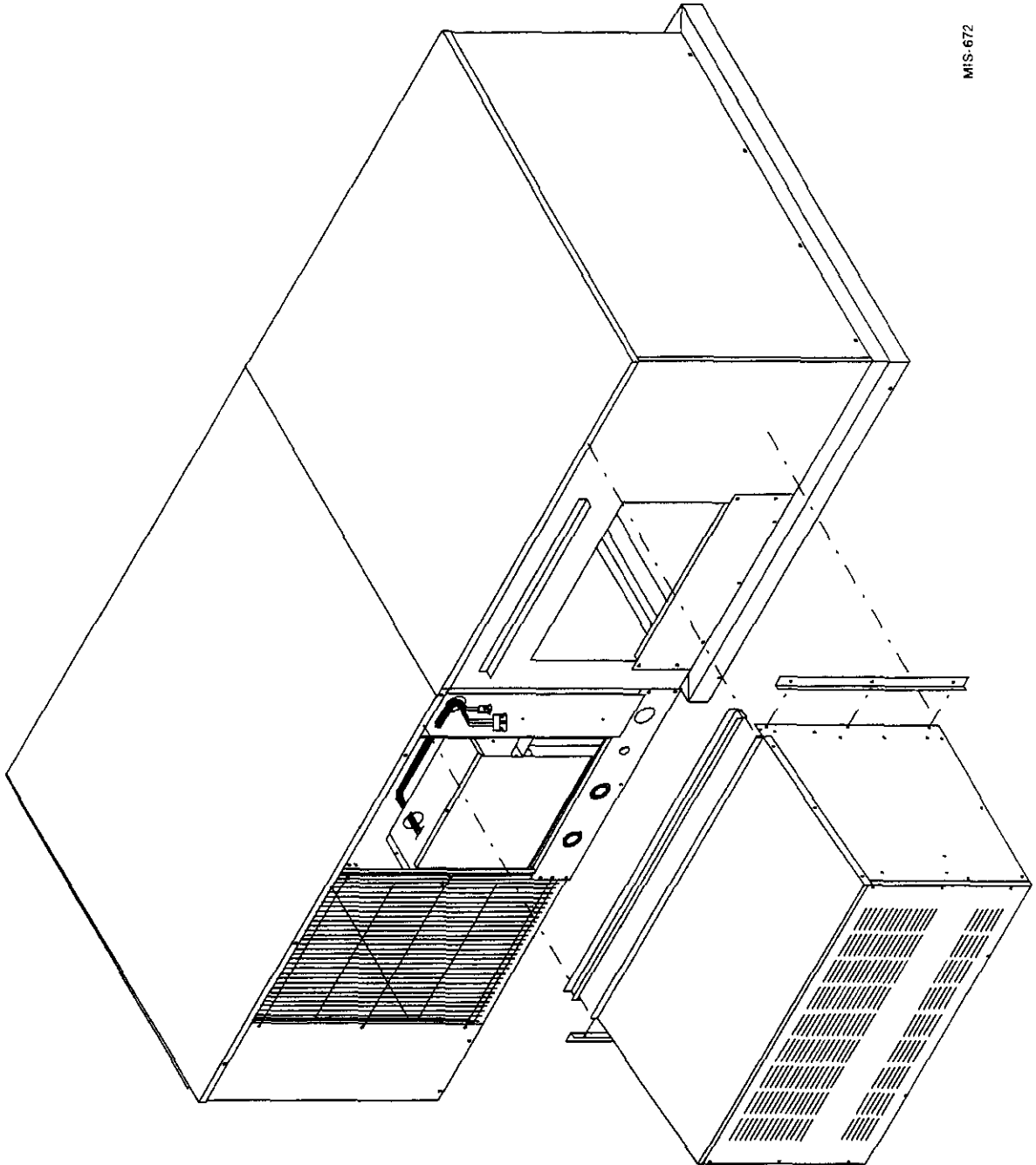
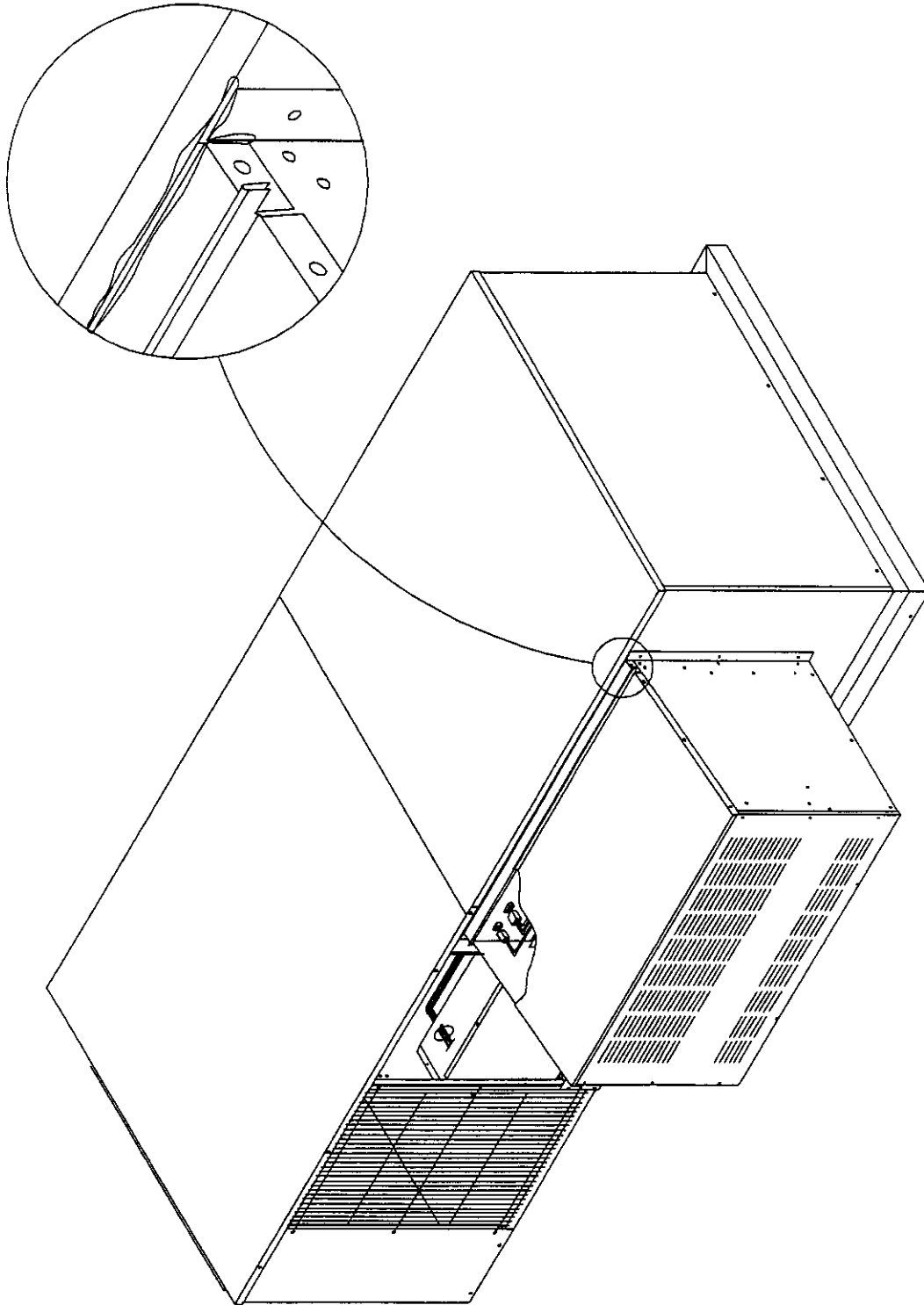

FIGURE 17



MIS-672

FIGURE 18



MIS-678

WAG SERIES INSTALLATION INSTRUCTIONS

1. Remove vent terminal and save. Remove upper and lower service doors and discard. (See Figure 19.)
2. Install wiring harness and wire per wiring diagram. (See Figures 20 and 23 or 24.)
3. Install ERVR on WAG and secure with self-drilling screws provided. (See Figure 21.)
4. Plug wiring harness into back of ERVR. (See Figure 21.)
5. Remove ERVR top and plug in ERVR to harness.
6. Install new lower and upper doors from 8620-108 kit. Reattach vent terminal. (See Figure 22.)
7. Go to Ventilator Checkout on Page 25.

FIGURE 19

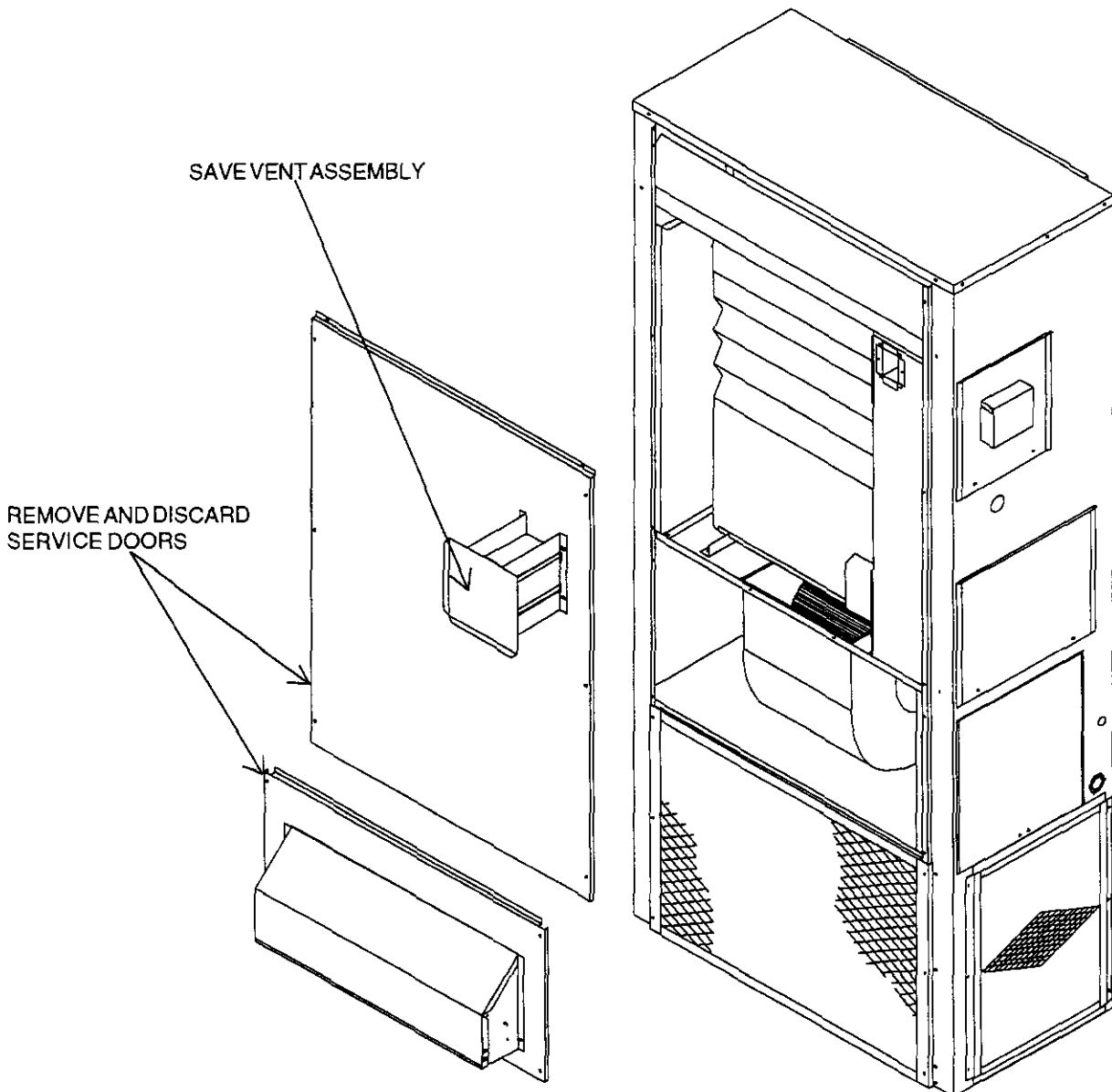

MIS-684

FIGURE 20

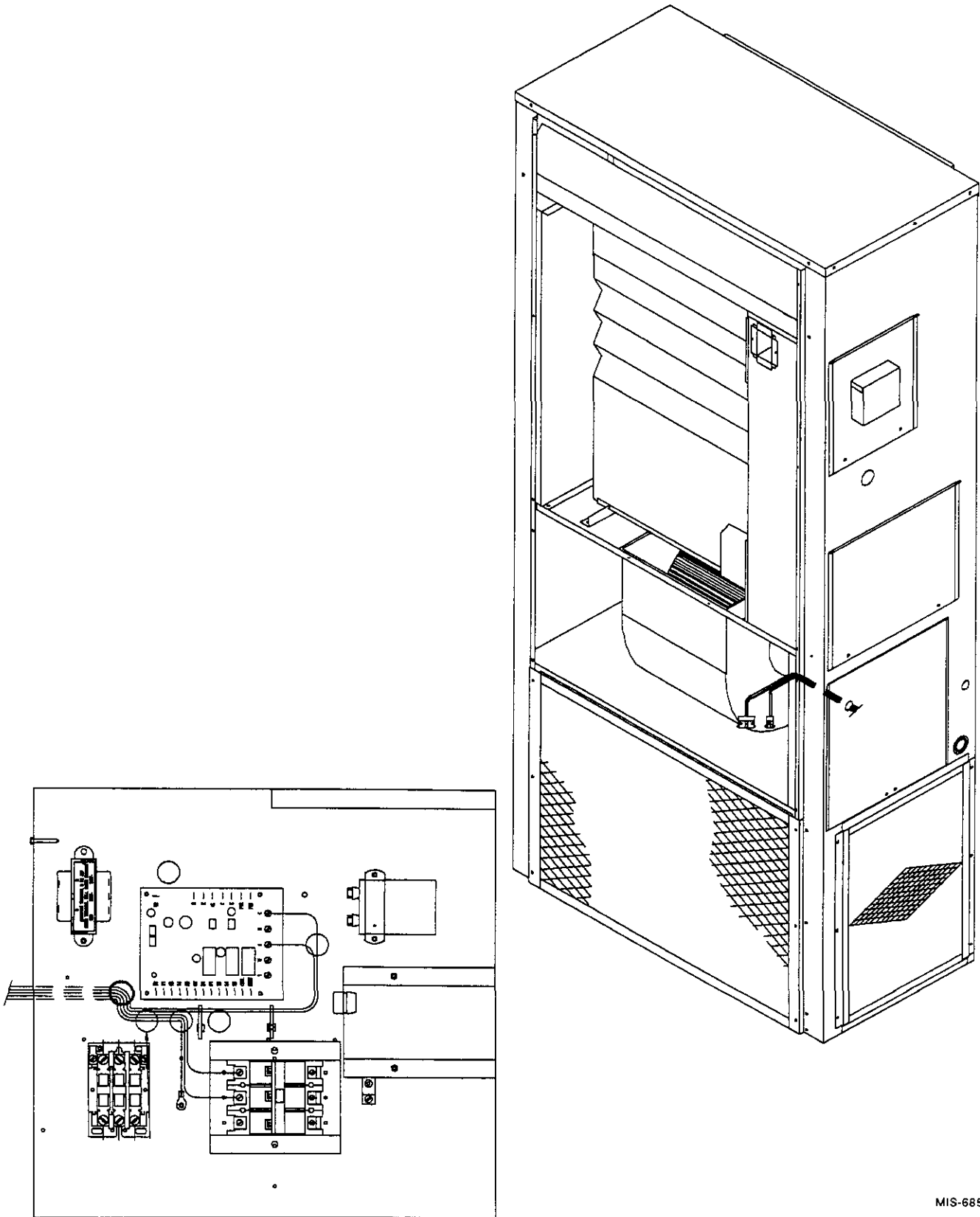

MIS-685

FIGURE 21

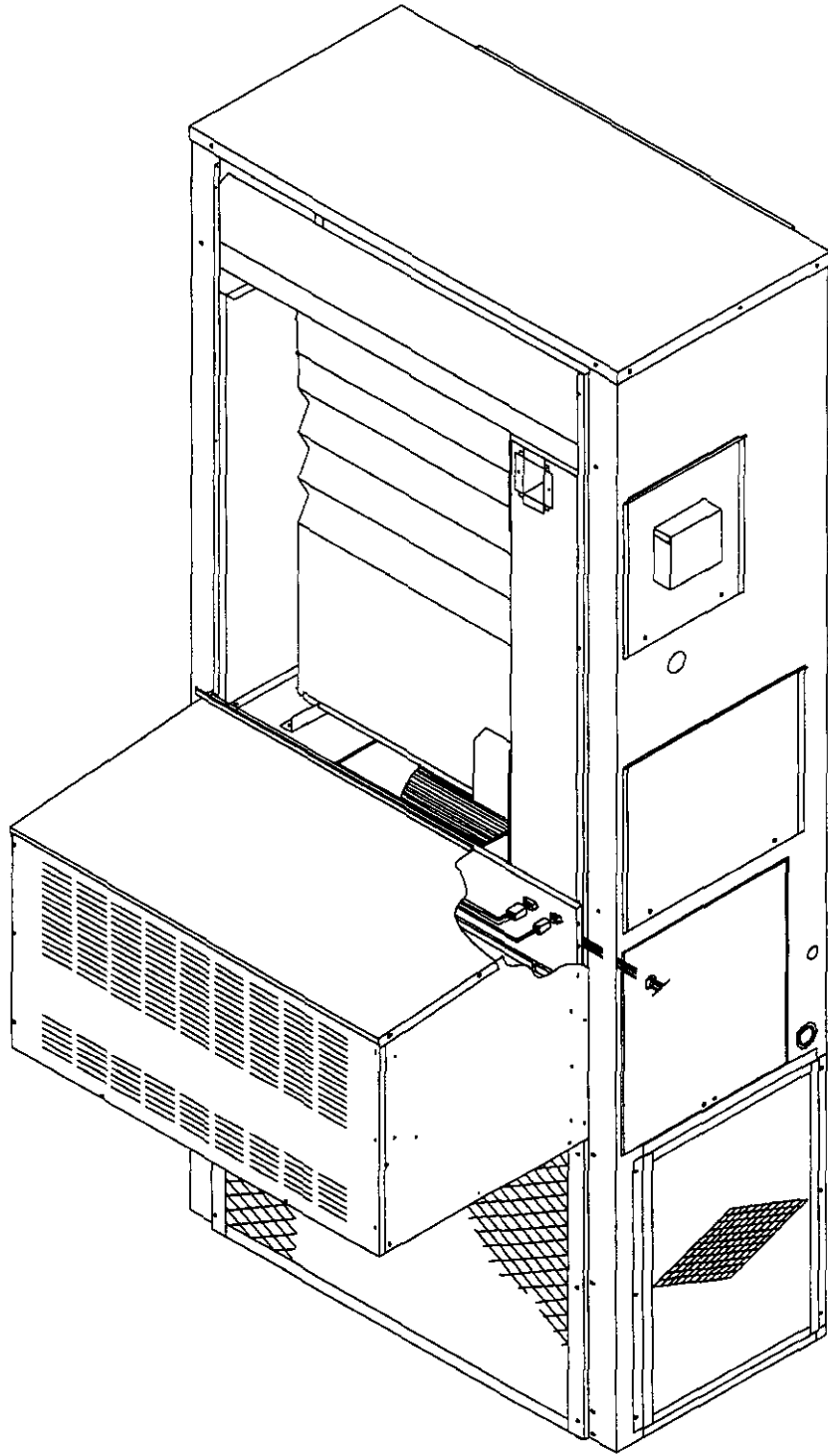

MIS-686

FIGURE 22

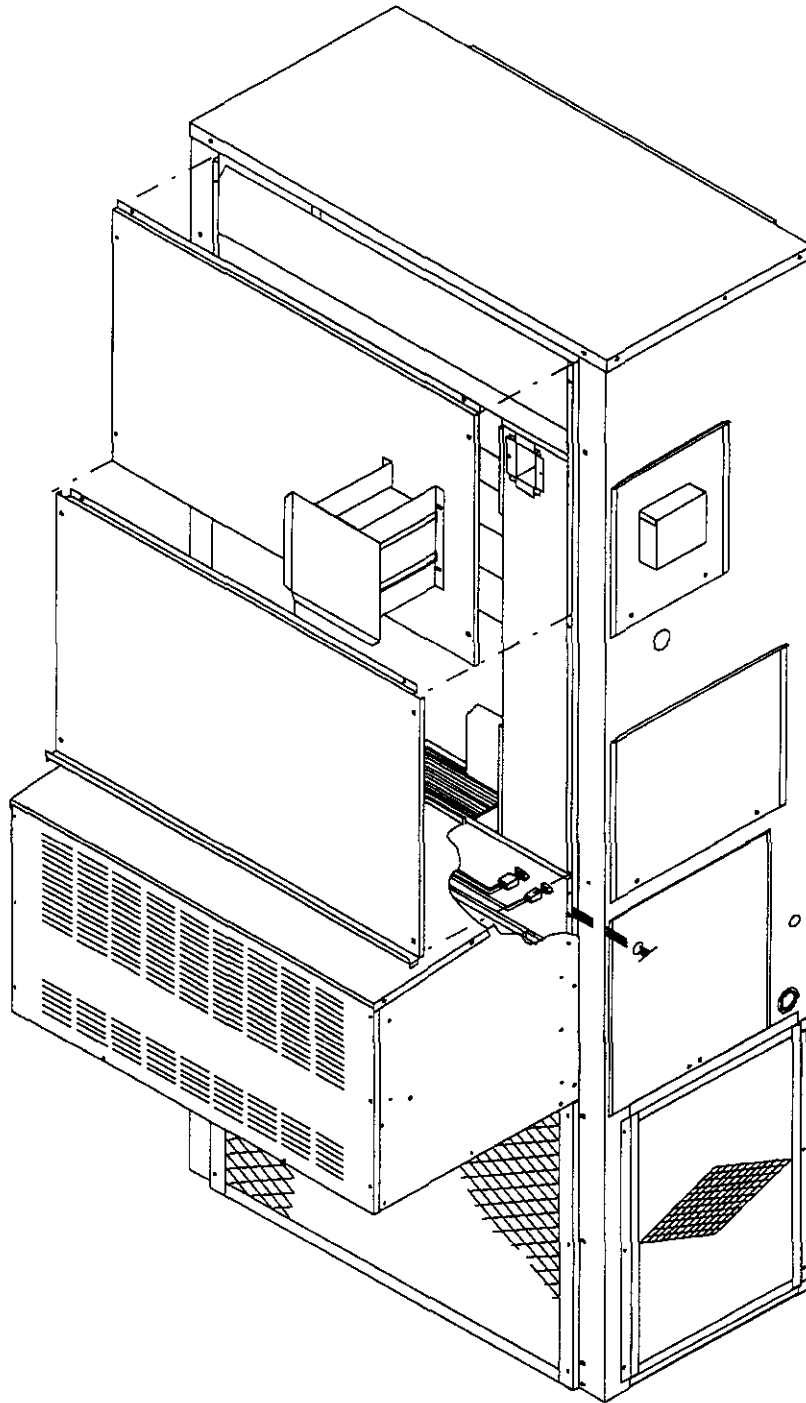

MIS-687

VENTILATOR CHECKOUT

1. Resupply power to unit.
2. Energize the evaporator blower by switching thermostat to the manual fan position with Heat/Cool in OFF position.
3. Ventilator heat transfer wheels should rotate slowly. (49 RPM). Intake and exhaust blowers should run.
4. De-energized evaporator blower. Energy recovery heat transfer wheels and fresh air exhaust air blowers should stop.
5. Reinstall top on ERVR.
6. This completes ventilator checkout.

CONTROL OPTIONS

The unit comes from the factory wired to provide ventilation whenever the indoor blower of the air conditioner or heat pump is operating. Continuous ventilation can be obtained by setting the wall thermostat on continuous fan.

For many applications such as schools, it may be more desirable and will reduce the operating cost, to shut the ventilation system off during periods of time when the building or room is not occupied.

This can be accomplished by providing a means to interrupt the orange wire from control relay CR1 (see wiring diagram) to "G" on the unit 24 volt terminal block. This can be accomplished with a manual switch, timer, programmable thermostat, Bard CS2000, or separate energy management system.

VENTILATION AIR FLOW

The ERVR is equipped with a 3 speed motor to provide the capability of adjusting the ventilation rates to the requirements of the specific application by simply changing motor speeds.

TABLE 3

VENTILATION AIR (CFM)			
Model	High Speed (Black)	Medium Speed (Blue)	Low Speed (Red)
ERVR	400	325	250

The units are wired from the factory on high speed. The speed can be changed by disconnecting the black wire and reconnecting the blue or red wire on the intake or exhaust blower motor. If desired, the fresh air motor can be wired on one speed and the exhaust motor on another if needed for a specific requirement.



WARNING

Open disconnect to shut all power off before changing wiring to change motor speed. Failure to do so could result in injury or death due to electrical shock.

SERVICING THE ERVR SYSTEM

1. Room air filters in the air conditioner should be cleaned or replaced periodically to maintain an adequate amount of total circulated air through the air conditioning system. The frequency of changing or cleaning is dependent on the application.
2. Fresh air filter. The unit is equipped with a fresh air filter and mist eliminator located in the ERVR. (See Figure 5.) This can be removed by removing the top from the ERVR and removing the filters from the top of the assembly. This filter is constructed of an aluminum frame and mesh and can be cleaned by washing periodically. The frequency is determined by the amount of dust, pollen and other outdoor airborne particles in the area. A periodic visual inspection is recommended to insure it is clean and free of dust, debris, leaves, snow etc.

ENERGY TRANSFER WHEEL

NOTE: Discoloration and staining of the wheel does not affect its performance. Only excessive build up of foreign material needs to be removed.

If the wheels appear excessively dirty, they should be cleaned to insure maximum efficiency. To clean the wheels, remove the service access panel. (See Figure 1.) Remove the sheet metal access panel on the front of the Energy Recovery Ventilator. Unplug the (2) wheel drive motors at the plug-in connectors located below the heat transfer wheels. (Squeeze the side tabs on the connector and pull gently. Do not pull on the wires.) Remove the heat transfer cassette by grasping the tray and sliding out of the unit. Remove the wheels from the cassette assembly. Grasp the wheel by the rim and thoroughly spray the wheel windings with a household spray cleaner such as Fantastic or the equivalent. Gently rinse with warm water and use a soft brush (such as a paint brush) to remove any heavy accumulation. Shake the excess water from the wheel and reinstall in reverse order. Operate the unit to confirm proper operation.

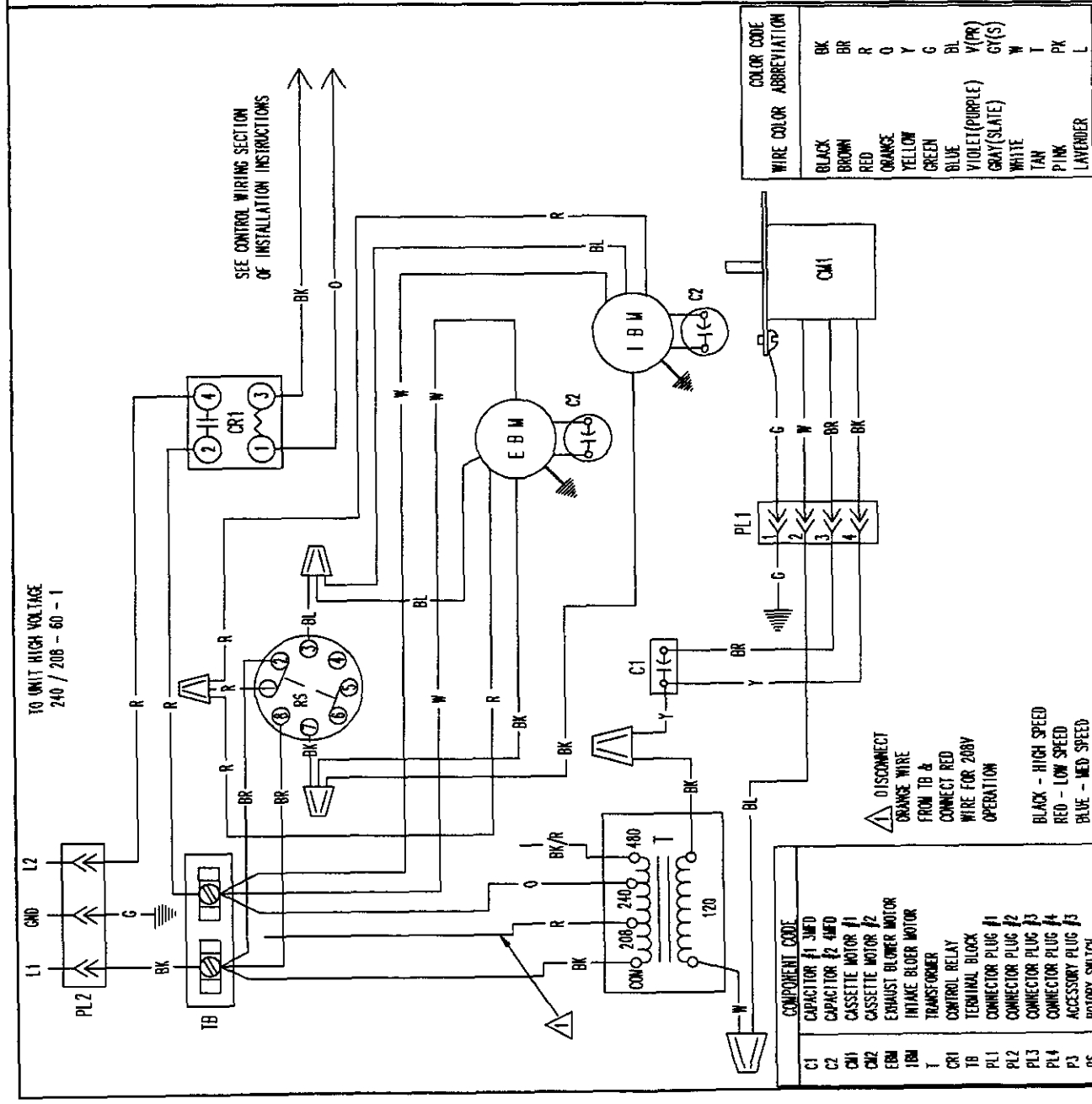
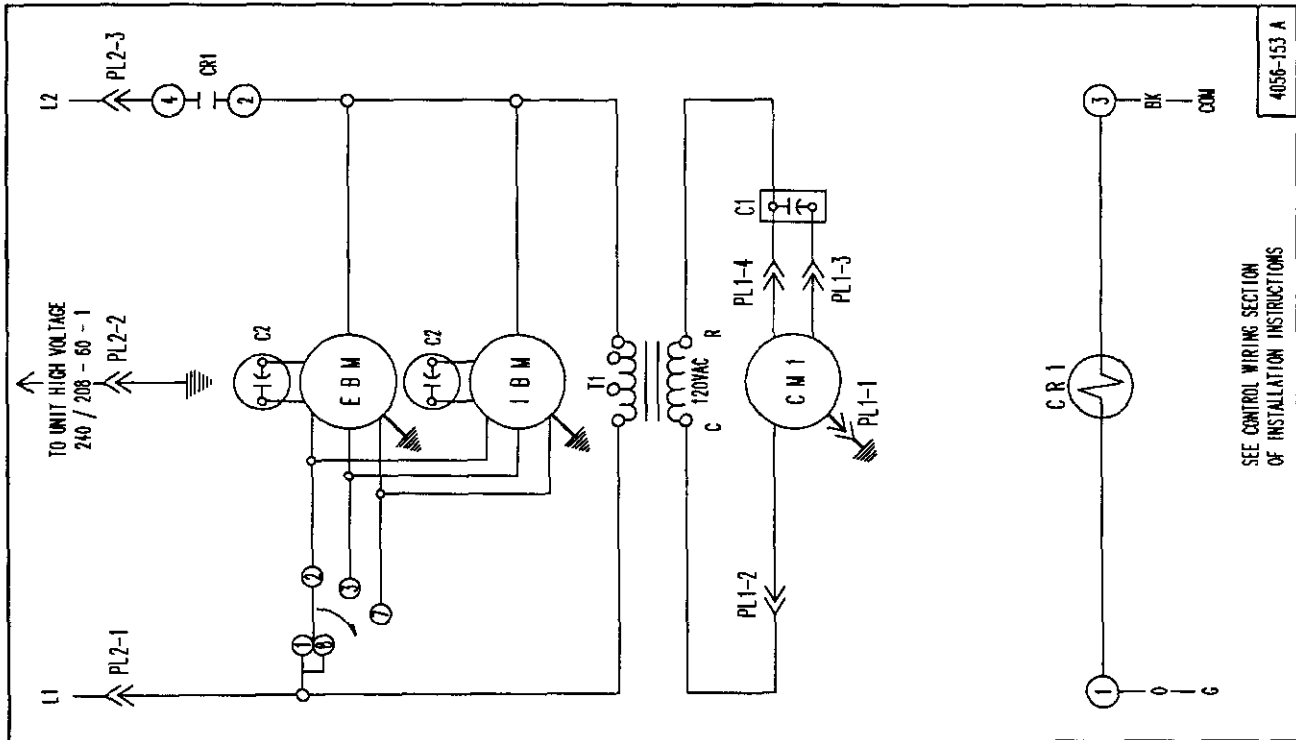

WIRE COLOR	COLOR CODE ABBREVIATION
BLACK	BK
BROWN	BR
RED	R
ORANGE	O
YELLOW	Y
GREEN	G
BLUE	BL
VIOLET (PURPLE)	V(PR)
GRAY (SLATE)	GY(S)
WHITE	W
TAN	T
PINK	PK
LAVERGER	L

COMPONENT CODE	DESCRIPTION
C1	CAPACITOR #1 5MFD
C2	CAPACITOR #2 4MFD
CM1	CASSETTE MOTOR #1
CM2	CASSETTE MOTOR #2
EBM	EXHAUST BLOWER MOTOR
IBM	INTAKE BLOWER MOTOR
T	TRANSFORMER
CR1	CONTROL RELAY
TB	TERMINAL BLOCK
PL1	CONNECTOR PLUG #1
PL2	CONNECTOR PLUG #2
PL3	CONNECTOR PLUG #3
PL4	CONNECTOR PLUG #4
P3	ACCESSORY PLUG #3
RS	ROTOR SWITCH

△ DISCONNECT ORANGE WIRE FROM TB & CONNECT RED WIRE FOR 208V OPERATION
 BLACK - HIGH SPEED
 RED - LOW SPEED
 BLUE - MED SPEED

SEE CONTROL WIRING SECTION OF INSTALLATION INSTRUCTIONS

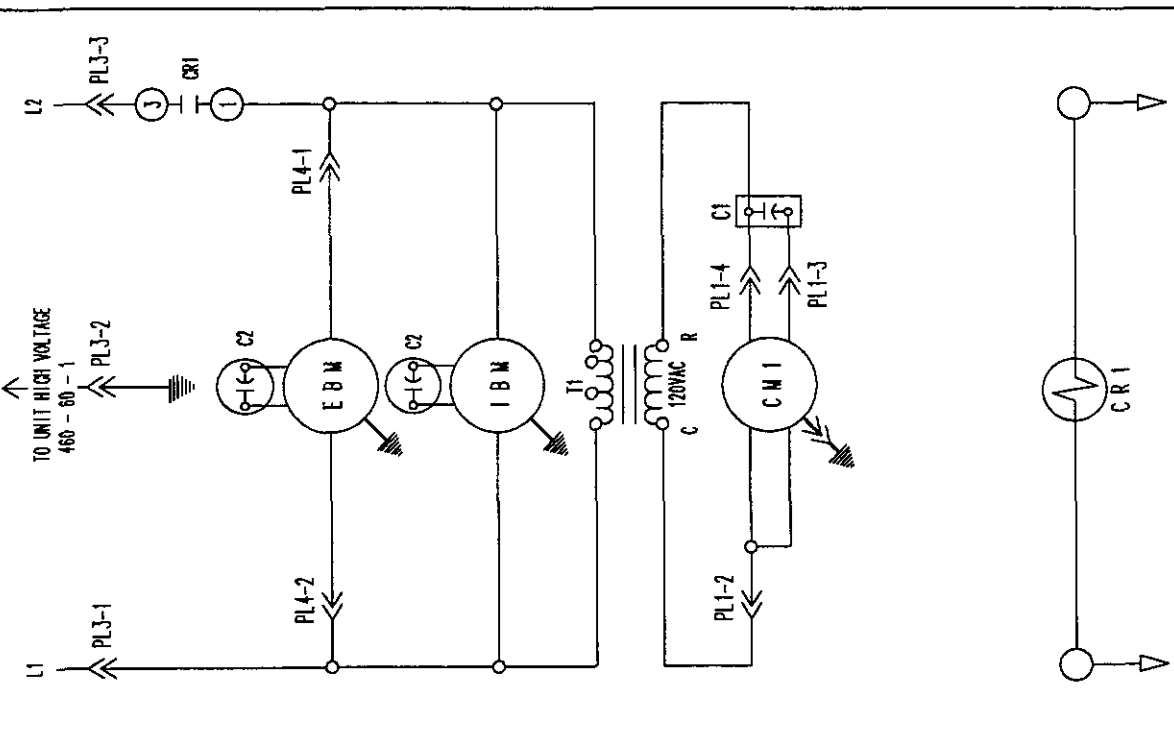
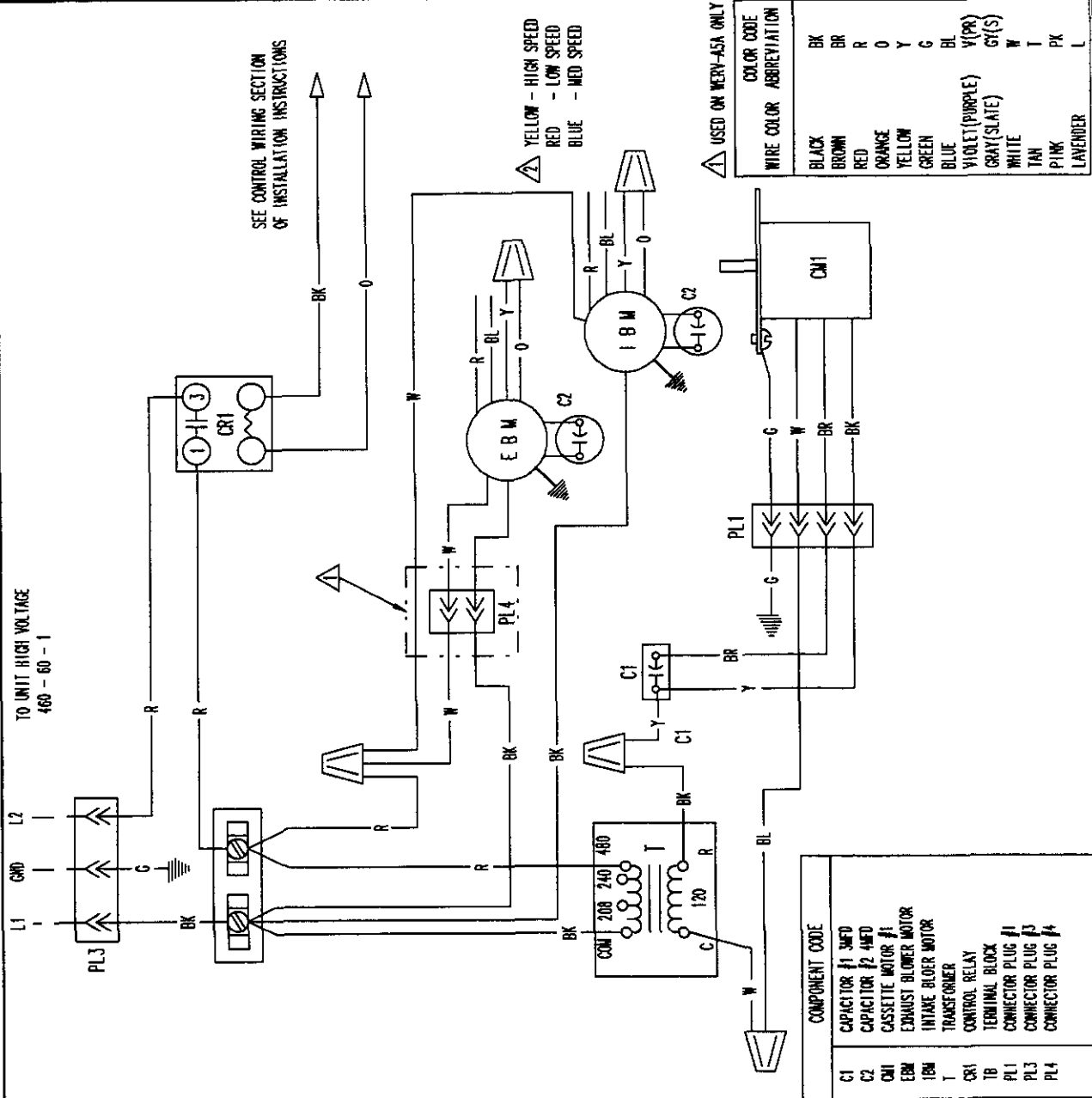

SEE CONTROL WIRING SECTION
OF INSTALLATION INSTRUCTIONS

