



# OPERATION INSTRUCTIONS

---

**MODEL: QEFM-4**

**ECONOMIZER WITH EXHAUST**

**FOR USE WITH BARD  
2 THRU 4 TON  
QTEC SERIES HEAT PUMPS**

---

**BARD MANUFACTURING COMPANY**  
**Bryan, Ohio 43506**

*Since 1914...Moving ahead, just as planned.*

Manual:	2100-311
Supersedes:	
File:	Volume II, Tab 14
Date:	10-31-97

# Contents

---

## Contents

General Information .....	1
Description .....	1
Economizer Adjustment .....	1
Economizer – QTec Series Features .....	2
Economizer Sequence of Operation .....	2

## Figures

Figure 1 – Economizer Operation Chart .....	3
Figure 2 – Damper Motor .....	4
Figure 3 – Mechanical Cooling Operation .....	5
Figure 4 – Economizer Operation .....	6
Figure 5 – Economizer Wiring Diagram .....	7

**COPYRIGHT OCTOBER 1997  
BARD MANUFACTURING COMPANY  
BRYAN, OHIO USA 43506**

## GENERAL INFORMATION

The Economizer is supplied as a pre-wired factory installed option. Every QTac unit equipped with an economizer must have a low ambient control installed. This control can be factory installed or field installed. If field installed, use kit CMH-7 for heat pump models.

## DESCRIPTION

The QEFM-4 economizer is designed to be used with Bard 2 thru 4 ton QTac series heat pumps equipped with low ambient fan cycling controls. They are electromechanical economizer systems designed to provide "free" cooling where the outdoor air temperature is cool enough to provide the needed cooling without running the compressor. When cooling is needed, the system automatically takes advantage of the cold outdoor air when available and uses it for first stage cooling. This then reduces the need to run the air conditioning compressor providing lower operating costs and increasing the service life of the equipment. If the outdoor air gets too warm or humid to be helpful, the enthalpy control detects the condition and automatically closes the outdoor air and exhaust damper, opens the return air damper and switches to the compressor operation. This is all done automatically to achieve maximum savings without attention from the user. See Figure 1 on Page 3 for a block diagram of the economizer operation logic flow. The unit is equipped with a full modulating type damper motor which controls the damper position to a factory set minimum supply air temperature.

MODEL	FOR USE WITH THE FOLLOWING UNITS
QEFM-4	QH241 QH301 QH361 QH421 QH481

## ECONOMIZER ADJUSTMENT

1. Remove filter service door. Locate the minimum position potentiometer. (See Figure 2.)
2. Energize the evaporator blower by switching the thermostat to the manual fan position with the heat/cool switch in the OFF position.
3. Cycle the minimum position potentiometer (factory set for 0% fresh air) to full open. (See Figure 2.) Throughout checkout procedure observe operation of damper to insure there is free, unobstructed operation through the entire angle of damper travel. Then adjust the damper minimum open position to meet local codes or application requirements. (See example following.)

### EXAMPLE:

- a. Measure return air temperature (RAT) – (assume 75° F for example)
- b. Measure outdoor air temperature (OAT) – (assume 60° F for example)

- c. Calculate the mixed air temperature (MAT) which will result from the desired combination of OAT (10 percent) and RAT (90 percent).  
 $.1 \text{ OAT} + .9 \text{ RAT} = \text{MAT}$  or substituting example values  
 $.1 (60^\circ \text{ F}) + .9 (75^\circ \text{ F}) = 73.5^\circ \text{ F}$
  - d. Adjust the minimum position potentiometer knob until proper mixed air temperature as calculated above is reached. Care should be taken to insure thermometer is sensing air that is well mixed.
  - e. Mark correct setting on dial of minimum position potentiometer for future reference.
4. Adjust the enthalpy control to position A, B, C, or D to achieve the maximum combination of temperature and humidity acceptable for the installation as per the chart below. (The suggested setting is between A and B 70° DB @ 55 percent RH. It is further recommended to always set the control at C or above.) See Figure 2.

	Dial Setting	20% RH	50% RH	80% RH
Enthalpy Control Setting	A	78° F (26° C)	73° F (23° C)	68° F (20° C)
	B	73° F (23° C)	68° F (20° C)	63° F (17° C)
	C	68° F (20° C)	63° F (17° C)	59° F (15° C)
	D	63° F (17° C)	59° F (15° C)	53° F (12° C)

5. Switch the thermostat fan control to automatic and position the heat/cool switch to COOL. Adjust the thermostat temperature to engage the first stage of cooling only (Y). This will cause the dampers to modulate to achieve mixed air temperature of 55° provided outside air enthalpy is sufficiently low. If enthalpy is too high for economizing, low enthalpy can be simulated by temporarily jumping terminals S<sub>0</sub> and + of damper motor together. This will also cause the economizer damper to modulate away from minimum position. (Be sure to properly reconnect leads at end of checkout procedure.)
6. Readjust temperature on the thermostat to engage the second stage of cooling (Y2). The damper motor should return to previously set minimum positions.
7. Switch thermostat to OFF fan and OFF heat/cool positions to de-energize unit. Economizer damper should return to full closed (100 percent return air) position. Check out is complete.
8. Replace filter service door.

## **ECONOMIZER – QTec SERIES**

### **FEATURES:**

- One piece construction – easy to install with no mechanical linkage adjustment required.
- Exhaust air damper – built in with positive closed position. Provides exhaust air capability to prevent pressurization of tight buildings.
- Actuator motor – 24 volt, power open, spring return with built in torque limiting switch.
- Proportioning type control – for maximum "Free Cooling" economy and comfort with up to 50% outside air.
- Moisture eliminator and prefilter – permanent, washable aluminum construction.
- Enthalpy sensor to monitor outdoor temperature and humidity – adjustable.
- Minimum position potentiometer – adjustable to control minimum damper blade position.
- Mixed air sensor to monitor outdoor and return air to automatically modulate damper position.

### **ECONOMIZER SEQUENCE OF OPERATION**

#### **Condition A – Cool Outdoors**

First stage cooling closes and powers the economizer dampers to economizer mode and the indoor blower starts. Mixed air sensor senses a mixture of return air and outdoor air and modulates the dampers accordingly. Compressor operation is inhibited. (See Figure 3.)

If second stage closes on the thermostat, the dampers return to the closed or minimum position setting and the compressor starts for mechanical cooling.

#### **Condition B – Warm Outdoors**

First stage cooling cycles the compressor and dampers remain in the mechanical cooling mode. (See Figure 4.)

FIGURE 1 – ECONOMIZER OPERATION FOR SINGLE-COMPRESSOR UNITS.

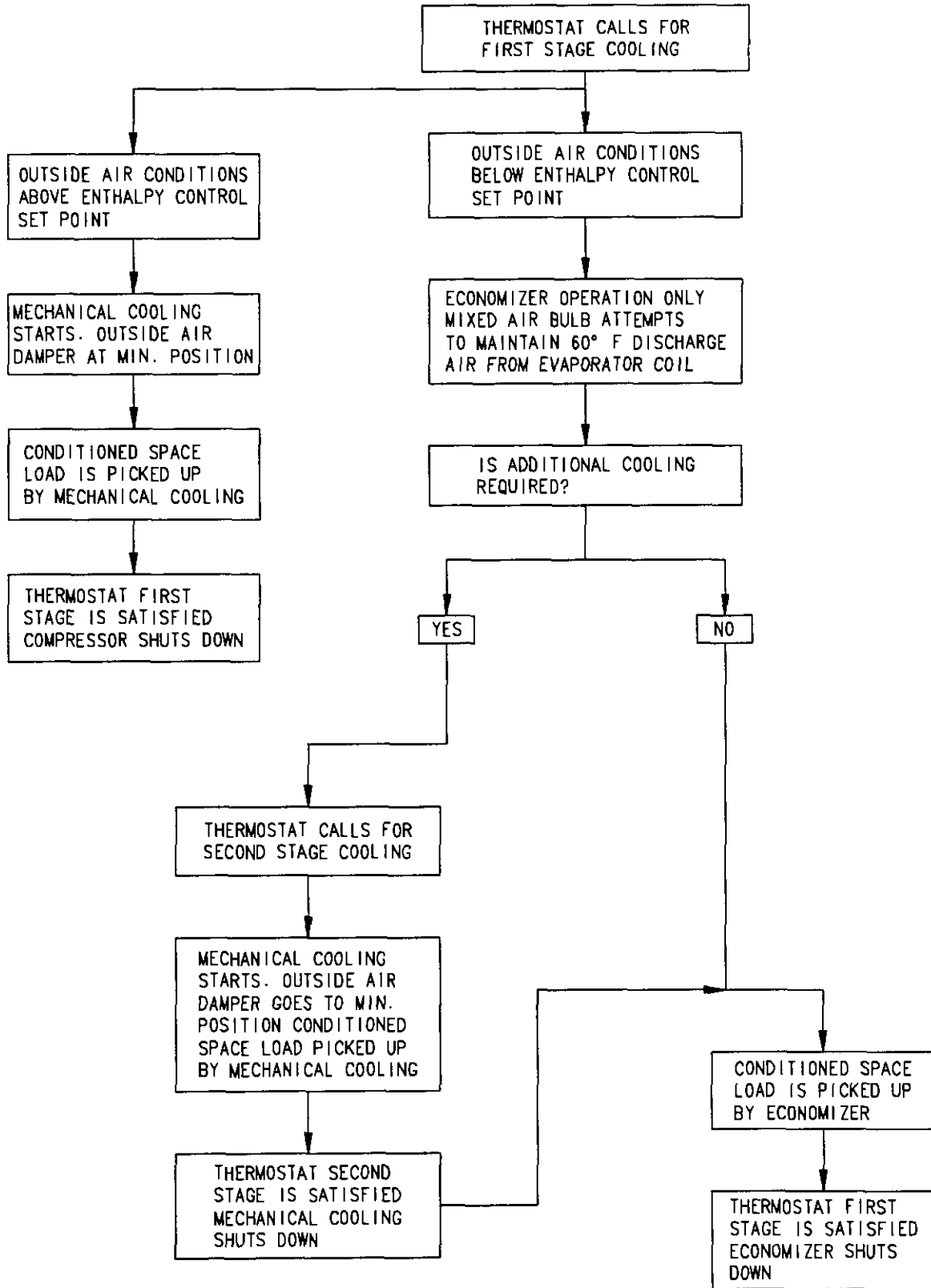

MIS-1147

FIGURE 2 - FRONT VIEW OF DAMPER MOTOR

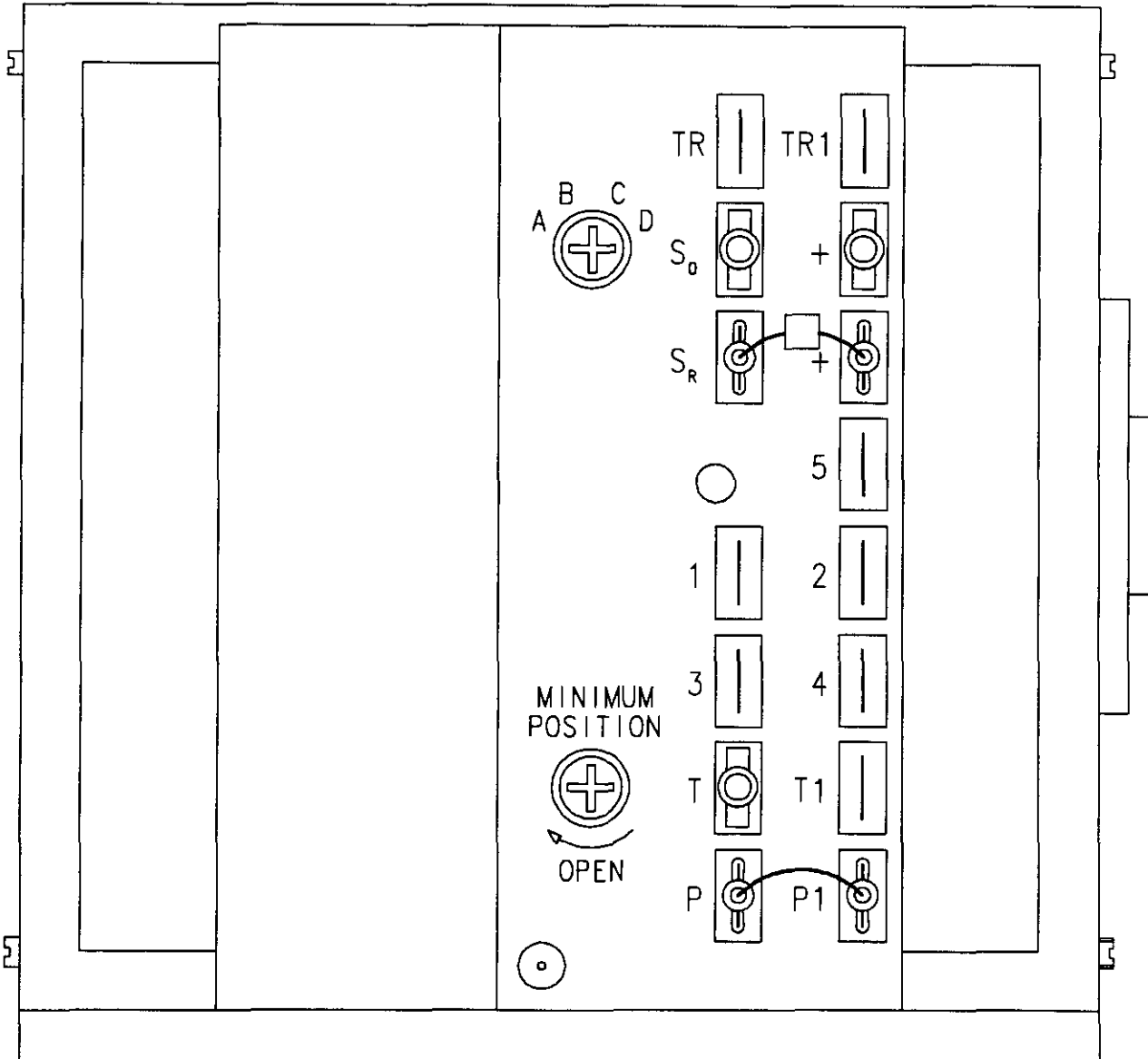

MIS-1146

FIGURE 3 - MECHANICAL COOLING OPERATION

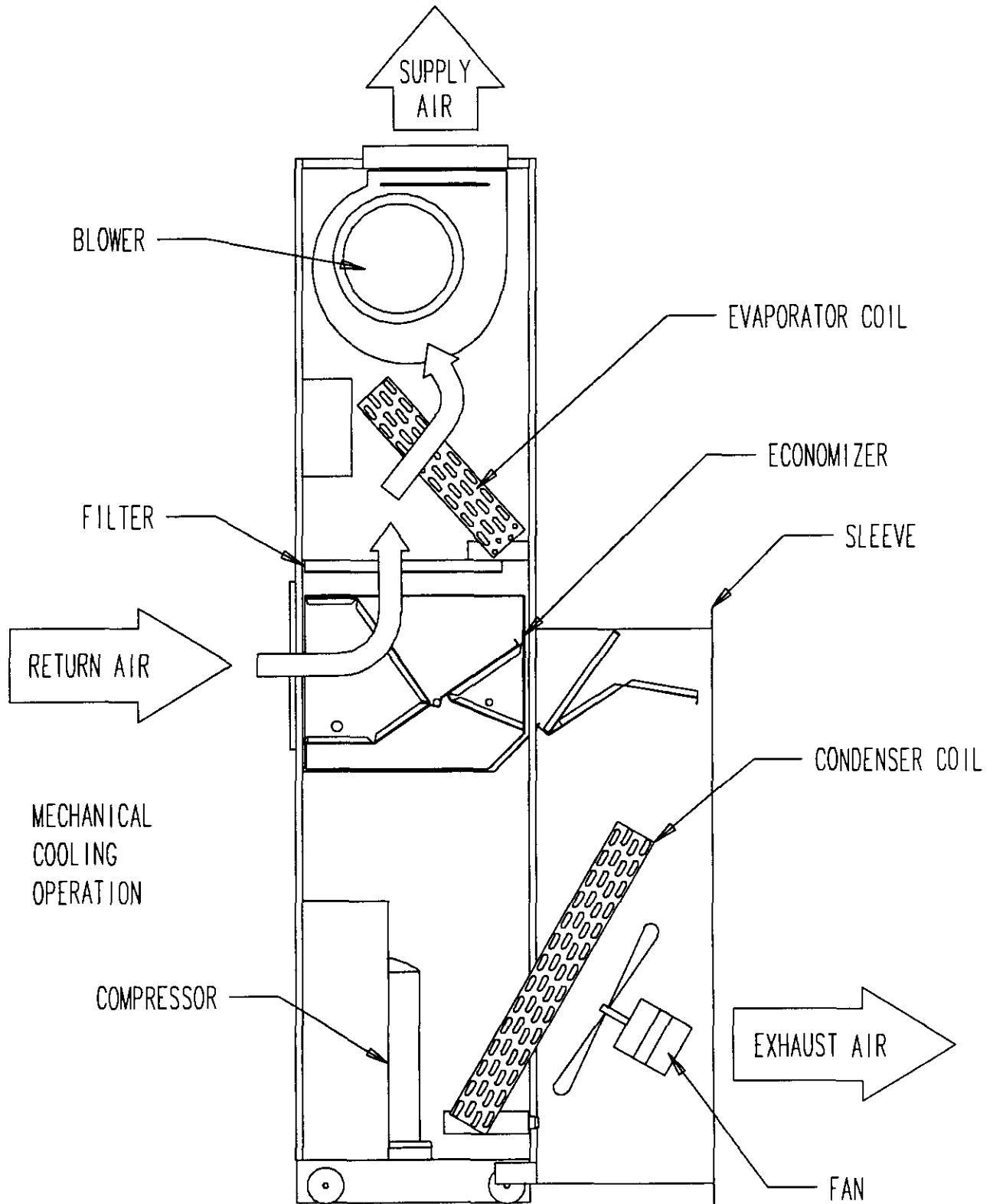

MIS-1144

FIGURE 4 - ECONOMIZER OPERATION

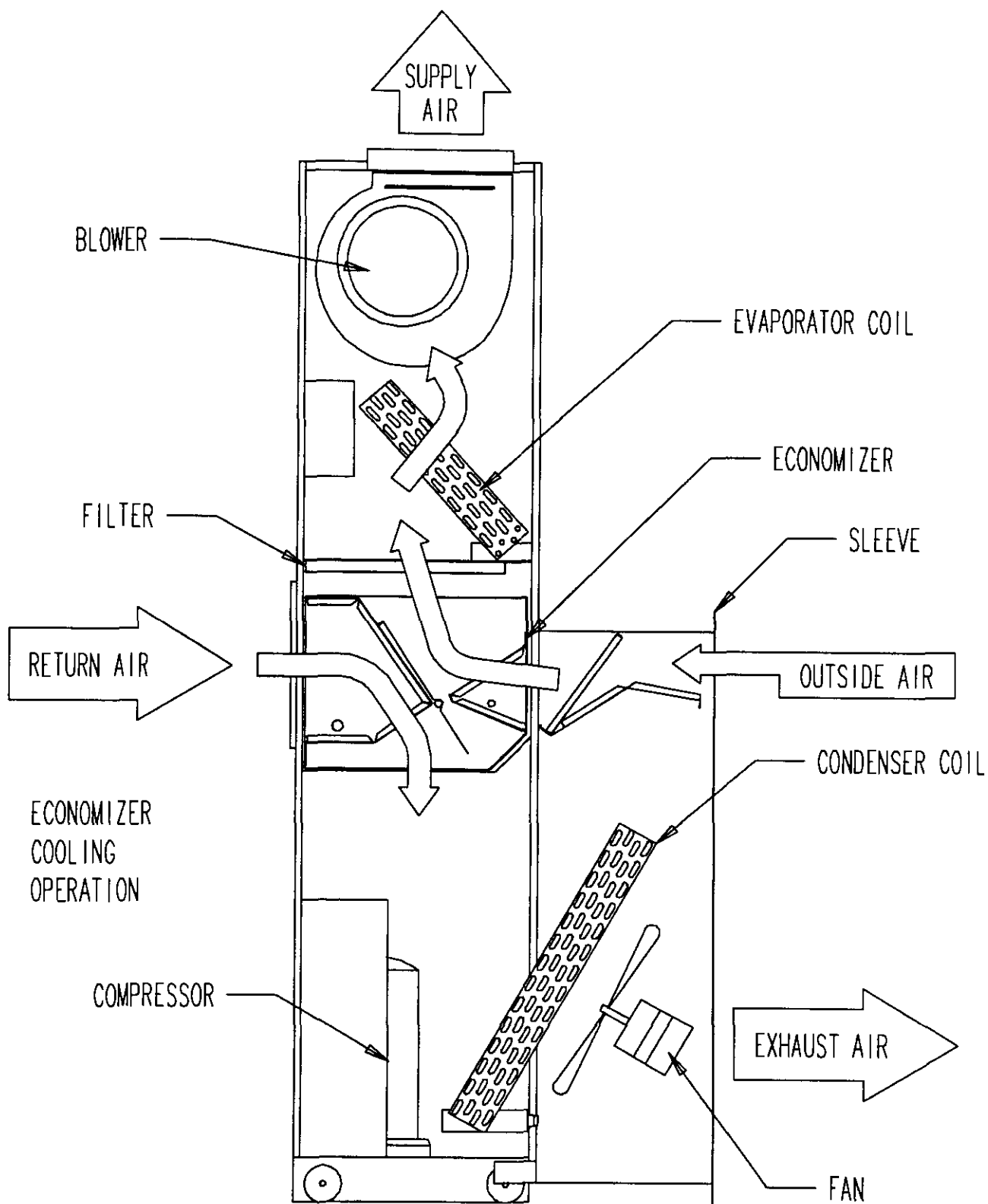

MIS-1145



FIGURE 5 - ECONOMIZER WIRING DIAGRAM

