



INSTALLATION INSTRUCTIONS

WALL MOUNTED CABINET AIR CONDITIONER

**MODEL:
CT241**

BARD MANUFACTURING COMPANY
Bryan, Ohio 43506

Since 1914...Moving ahead, just as planned.

Manual: 2100-314C
Supersedes: 2100-314B
File: Volume II, Tab 15
Date: 08-31-98

Contents

GETTING OTHER INFORMATION AND PUBLICATIONS	1
GENERAL INFORMATION	2
CT Model Nomenclature	2
Shipping Damage	4
General	4
Duct Work	4
Installation Clearances	4
Filters	4
Condensate Drain	4
INSTALLATION INSTRUCTIONS	5
Wall Mounting Information	5
Mounting the Unit	5
Wiring – Main Power	5
Wiring – Low Voltage Wiring	5
How to Set an Adjustable Anticipator	11
Additional Information for Electric Heat or Heat Pump Applications	11
START-UP	12
Important Installer Note	12
Service Hints	12
Sequence of Operation	12
Compressor Safeguard Control	12
Pressure Service Ports	12
TROUBLE SHOOTING	13
Fan Blade Setting Dimensions	13
WIRING DIAGRAMS	15

FIGURES	
Figure 1 Unit Dimensions	3
Figure 2 Mounting Instructions	6
Figure 3 Mounting Instructions Using Optional MBC-2 Side Mounting Brackets	7
Figure 4 Common Wall Mounting Installations	8
Figure 5 Low Voltage Wiring	10
Figure 6 Setting Anticipator	11
Figure 7 Amprobe	11
Figure 8 Fan Blade Setting Dimensions	13

TABLES	
Table 1 Electric Heat Table	2
Table 2	2
Table 3 Thermostat Wire Size	9
Table 4 Wall Thermostat and Subbase Combinations	9
Table 5 Fan Blade Setting Dimensions	13
Table 6 Indoor Blower Performance	13
Table 7 Maximum ESP of Operation (Electric Heat Only)	13
Table 8 Pressure Table	14

Getting Other Information and Publications

These publications can help you install the air conditioner or heat pump. You can usually find these at your local library or purchase them directly from the publisher. Be sure to consult current edition of each standard.

- National Electrical Code ANSI/NFPA 70
- Standard for the Installation ANSI/NFPA 90A
of Air Conditioning and
Ventilating Systems
- Standard for Warm Air ANSI/NFPA 90B
Heating and Air
Conditioning Systems
- Load Calculation for Residential ACCA Manual J
Winter and Summer
Air Conditioning
- Duct Design for Residential ACCA Manual D
Winter and Summer Air Conditioning
and Equipment Selection

For more information, contact these publishers:

ACCA — Air Conditioning Contractors of America
1712 New Hampshire Avenue
Washington, DC 20009
Telephone: (202) 483-9370
Fax: (202) 234-4721

ANSI — American National Standards Institute
11 West Street, 13th Floor
New York, NY 10036
Telephone: (212) 642-4900
Fax: (212) 302-1286

**ASHRAE — American Society of Heating Refrigerating, and
Air Conditioning Engineers, Incorporated**
1791 Tullie Circle, N.E.
Atlanta, GA 30329-2305
Telephone: (404) 636-8400
Fax: (404) 321-5478

NFPA — National Fire Protection Association
Batterymarch Park
P.O. Box 9101
Quincy, MA 02269-9901
Telephone: (800) 344-3555
Fax: (617) 984-7057

CT Series General Information

CT Model Nomenclature

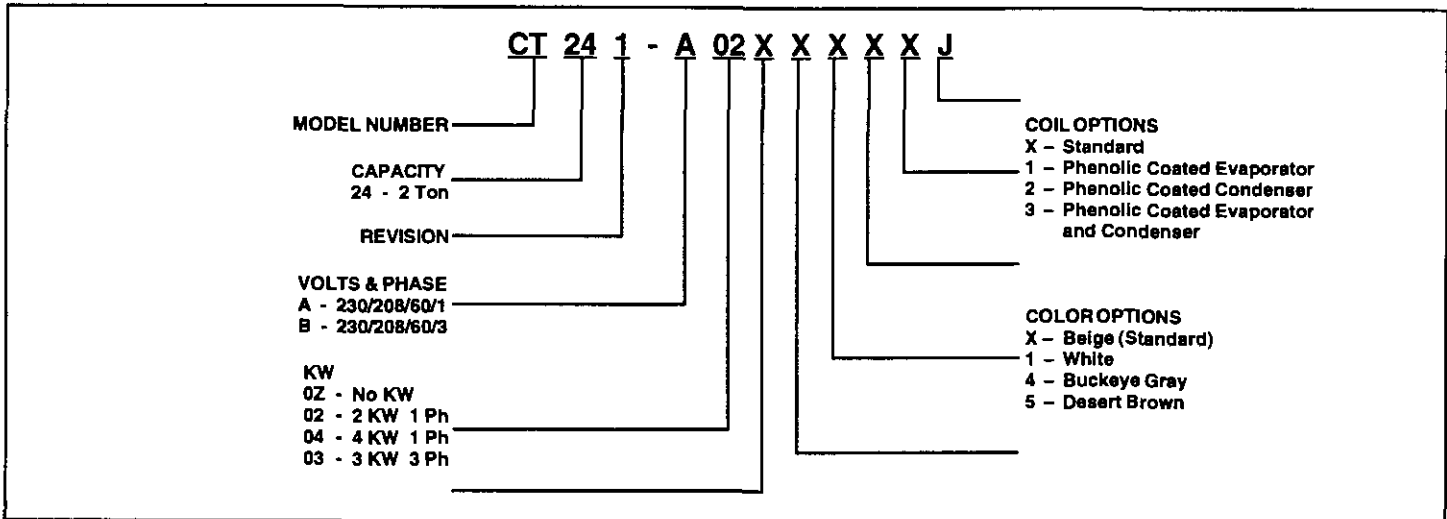

TABLE 1 - ELECTRIC HEAT TABLE

Models	CT241-A				CT241-B				
	240-1		208-1		240-1		208-1		
	KW	A	BTU	A	BTU	A	BTU	A	BTU
	2	8.3	6800	7.2	5100				
	4	16.7	13650	14.4	10230				
	3					7.2	10240	6.3	7650

TABLE 2

SINGLE CIRCUIT							
Model	Rated Volts and Phase	No. Field Power Circuits	(3) Minimum Circuit Ampacity	(1) Maximum External Fuse or Circuit Breaker	(2) Field Power Wire Size	(2) Ground Wire Size	Unit Wiring Diagram
CT241-A0Z	230/208-1	1	19	30	12	12	4104-100
A02		1	19	30	12	12	4104-110
A04		1	24	30	10	10	4104-120
CT241-B0Z	230-208-3	1	14	20	14	12	4104-200
B03		1	14	20	14	12	4104-210

- (1) Maximum size of the time delay fuse or HACR type circuit breaker for protection of fieldwiring conductors.
- (2) Based on 75°C copper wire. All wiring must conform to NEC and all local codes.
- (3) These "Minimum Circuit Ampacity" values are to be used for sizing the field power conductors. Refer to the National Electrical Code (latest revision), Article 310 for power conductor sizing. **CAUTION: When more than one field power conductor circuit is run through one conduit, the conductors must be derated. Pay special attention to Note 8 of Table 310 regarding Ampacity Adjustment Factors when more than 3 conductors are in a raceway.**

FIGURE 1 - UNIT DIMENSIONS

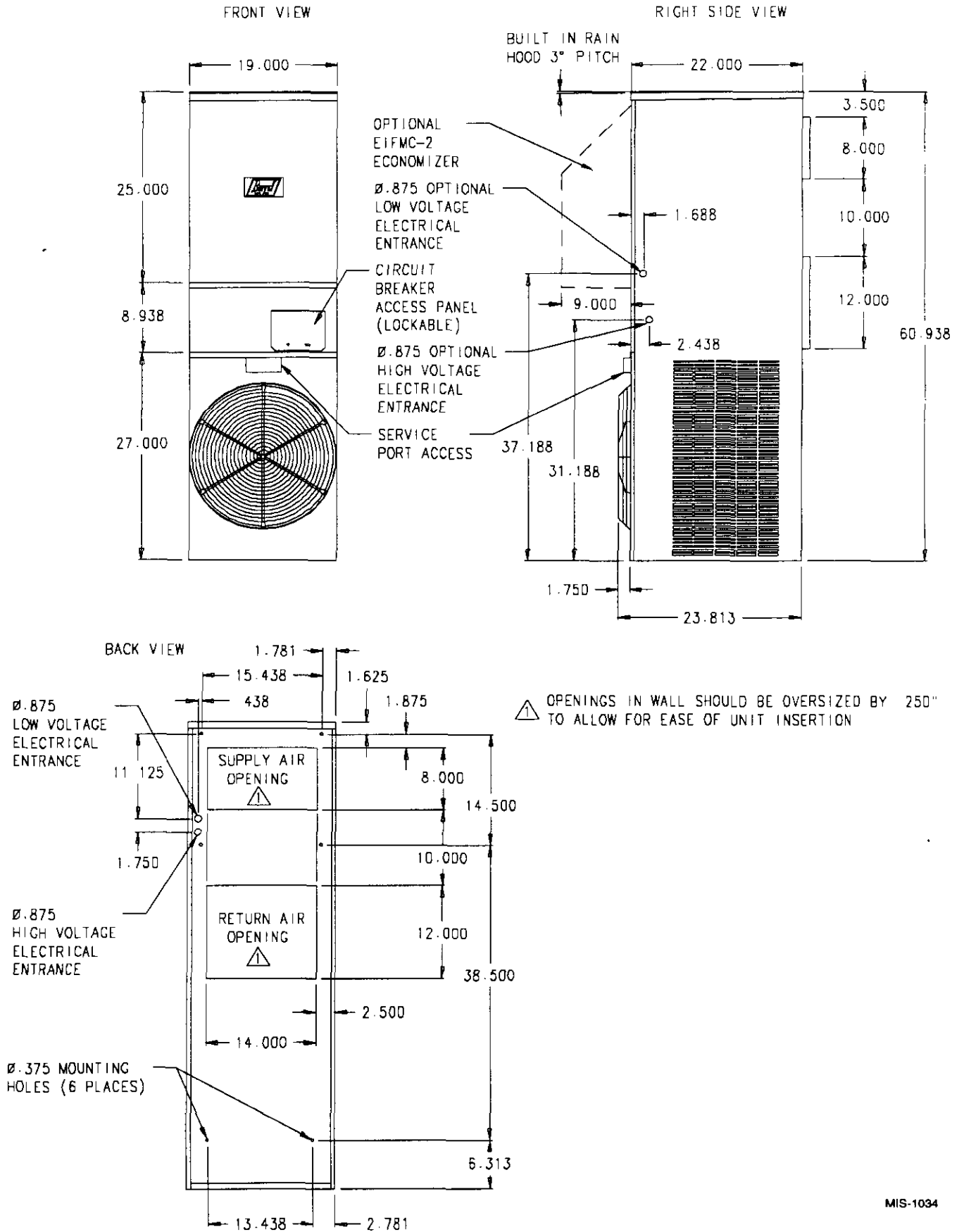

MIS-1034

GENERAL INFORMATION

SHIPPING DAMAGE

Upon receipt of equipment, the carton should be checked for external signs of shipping damage. If damage is found, the receiving party must contact the last carrier immediately, preferably in writing, requesting inspection by the carrier's agent.

GENERAL

The equipment covered in this manual is to be installed by trained, experienced service and installation technicians.

The refrigerant system is completely assembled and charged. All internal wiring is complete.

The unit is designed for use with or without duct work. Flanges are provided for attaching the supply and return ducts.

These instructions explain the recommended method to install the air cooled self-contained unit and the electrical wiring connections to the unit.

These instructions and any instructions packaged with any separate equipment required to make up the entire air conditioning system should be carefully read before beginning the installation. Note particularly "Starting Procedure" and any tags and/or labels attached to the equipment.

While these instructions are intended as a general recommended guide, they do not supersede any nation and/or local codes in any way. Authorities having jurisdiction should be consulted before the installation is made. See Page 1 for information on codes and standards.

Size of unit for a proposed installation should be based on heat loss calculation made according to methods of Air Conditioning Contractors of America (ACCA). The air duct should be installed in accordance with the Standards of the National Fire Protection Association for the Installation of Air Conditioning and Ventilating systems of Other Than Residence Type, NFPA No. 90A, and Residence Type Warm Air Heating and Air Conditioning Systems, NFPA No. 90B. Where local regulations are at a variance with instructions, installer should adhere to local codes.

DUCT WORK

All duct work, supply and return, must be properly sized for the design air flow requirement of the equipment. Air Conditioning Contractors of America (ACCA) is an excellent guide to proper sizing. All duct work or portions thereof not in the conditioned space should be properly insulated in order to both conserve energy and prevent condensation or moisture damage.

Refer to Table 6 for maximum static pressure available for duct design.

Design the duct work according to methods given by the Air Conditioning Contractors of America (ACCA). When duct runs through unheated spaces, it should be insulated with a minimum of one inch of insulation. Use insulation with a vapor barrier on the outside of the insulation. Flexible joints should be used to connect the duct work to the equipment in order to keep the noise transmission to a minimum.

Ducts through the walls must be insulated and all joints taped or sealed to prevent air or moisture entering the wall cavity.

Duct work, if used is approved for zero (0) inches to combustibles.

INSTALLATION CLEARANCES

Basic unit is approved for zero (0) inches to combustible to the rear of the unit.

The basic unit is approved for three (3) inches clearance on the left and right sides. The basic unit is approved for thirty-Six (36) inches clearances to front of unit.

FILTERS

No filter is supplied with unit. A return filter grille is required (Bard Return Filter Grille RFGC-2) must be installed with a one inch washable filter (Bard Filter 7003-048). Both parts must be ordered separately.

CONDENSATE DRAIN

A plastic drain hose extends from the drain pan at the top of the unit down to the unit base. There are openings in the unit base for the drain hose to pass through. In the event the drain hose is connected to a drain system of some type, it must be an open or vented type system to assure proper drainage.

INSTALLATION INSTRUCTIONS

WALL MOUNTING INFORMATION

1. These units are secured by mounting the unit to the outside wall surface from inside the unit. Field installed mounting brackets which secure the unit externally from both sides are available as accessory items.
2. On wood frame walls, the wall construction must be strong and rigid enough to carry the weight of the unit without transmitting any unit vibration. On wood frame walls, unit requires supply and return air sleeve.
3. Concrete block walls must be thoroughly inspected to insure that they are capable of carrying the weight of the unit to be installed.

MOUNTING THE UNIT

1. Two holes for the supply and return air openings, must be cut through the wall as shown in Figure 2 on Page 6.
2. Locate and mark lag bolt locations and bottom mounting bracket location, if desired. (See Figure 2.)
3. Mount bottom mounting bracket if used. (Optional)
4. Hook top rain flashing under back bend of top. Top rain flashing is shipped attached to the back of the unit on the right side. (See Figure 2.)
5. Position unit in opening and secure with 5/16 lag bolts. Use 5/16 inch diameter flat washers on the lag bolts.
6. Secure rain flashing to wall and caulk across entire length of top. (See Figure 2.)
7. For additional mounting rigidity, the return air and supply air frames or collars can be drilled and screwed or welded to the structural wall itself (depending upon wall construction).

NOTE: Approved for 0 inches clearance to combustible surfaces.

8. On side by side installations, maintain a minimum of 3 inches clearance on side to allow proper airflow to outdoor coil.

Figure 4 on Page 8 illustrates some common wall mounting installations.

NOTE: Optional side mounting brackets can be used. Secure brackets to cabinet using common side screws. Secure brackets to wall with 5/16 inch lag bolts and 5/16 inch diameter washers. (See Figure 3 on Page 7.)

WIRING – MAIN POWER

Refer to the unit rating plate for wire sizing information and maximum fuse of "HACR Type" circuit breaker size. Each outdoor unit is marked with a "Minimum Circuit Ampacity". This means that the field wiring used must be sized to carry that amount of current. All models are suitable only for connection with copper wire. Each unit and/or wiring diagram will be marked "Use Copper Conductors Only". These instructions *MUST* be adhered to. Refer to the National Electrical Code (NEC) for complete current carrying capacity data on the various insulation grades of wiring material. All wiring must conform to NEC and all local codes.

The electrical data lists fuse and wire sizes (75°C copper) for all models including the most commonly used heater sizes.

The unit rating plate lists a "Maximum Time Delay Relay Fuse" or "HACR Type" circuit breaker that is to be used with the equipment. The correct size must be used for proper circuit protection and also to assure that there will be no nuisance tripping due to the momentary high starting current of the compressor motor.

The disconnect access door on this unit may be locked to prevent unauthorized access to the disconnect. To convert for the locking capability, bend the tab located in the bottom left hand corner of the disconnect opening under the disconnect access panel straight out. This tab will now line up with the slot in the door. When shut a padlock may be placed through the hole in the tab preventing entry.

WIRING – LOW VOLTAGE WIRING

All models are equipped with dual primary voltage transformers. All equipment leaves the factory wired on 240V tap. For 208V operation, reconnect from 240V to 208V tap. The acceptable operating voltage range for the 240V and 208V taps are:

TAP	RANGE
240	253 -- 216
208	220 -- 187

NOTE: The voltage should be measured at the field power connection point in the unit and while the unit is operating at full load (maximum amperage operating condition).

FIGURE 2 - MOUNTING INSTRUCTIONS

NOTE: IT IS RECOMMENDED THAT A BEAD OF SILICONE BE APPLIED ALONG SIDES OF UNIT AND UNDER RAIN FLASHING

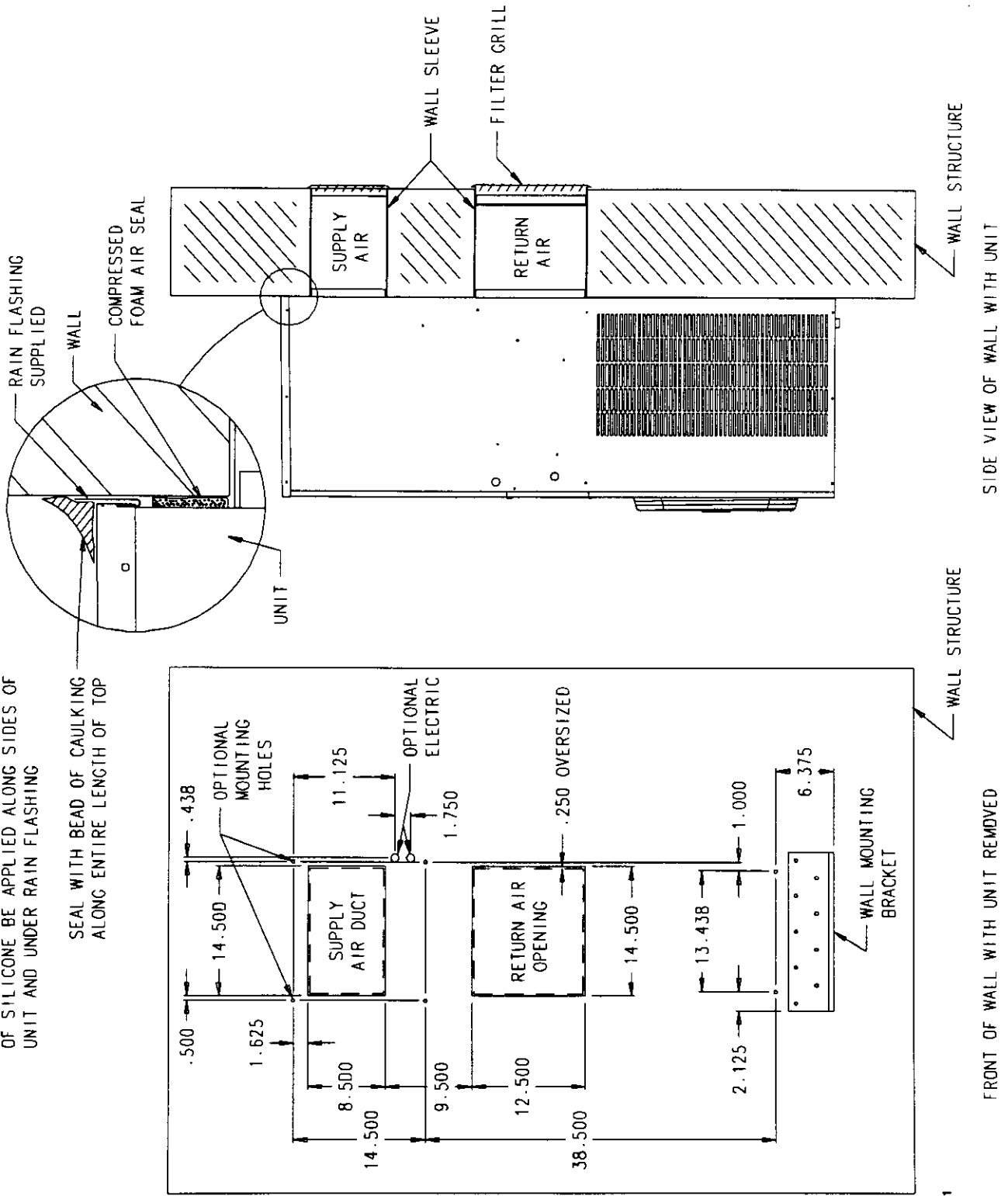

MIS-1151

FIGURE 3 - MOUNTING INSTRUCTIONS USING OPTIONAL MBC-2 SIDE MOUNTING BRACKETS

NOTE: IT IS RECOMMENDED THAT A BEAD OF SILICONE BE APPLIED BEHIND SIDE MOUNTING ANGLES AND UNDER RAIN FLASHING

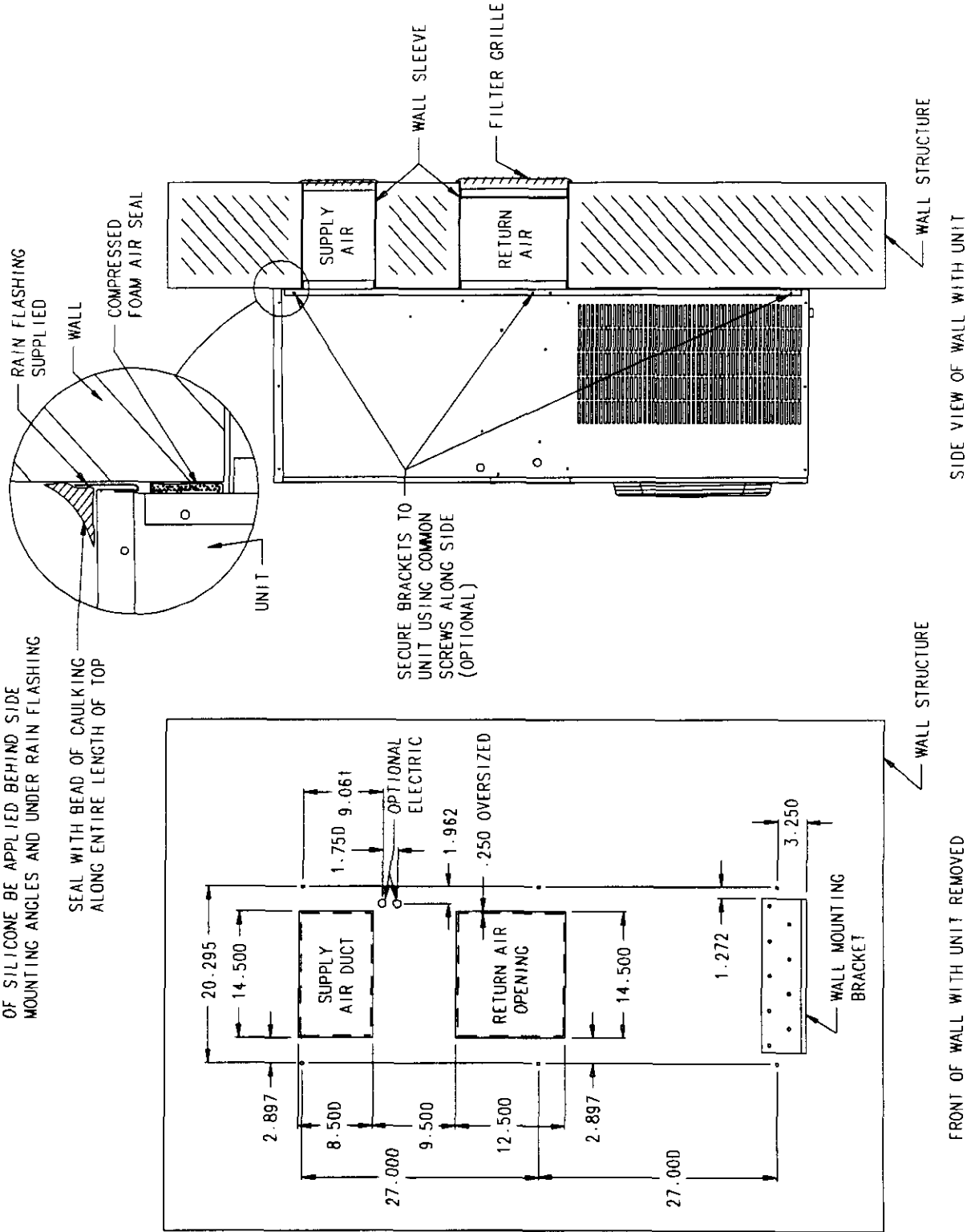

MIS-1163

FIGURE 4 - COMMON WALL MOUNTING INSTALLATIONS

FREE AIR FLOW, NO DUCT

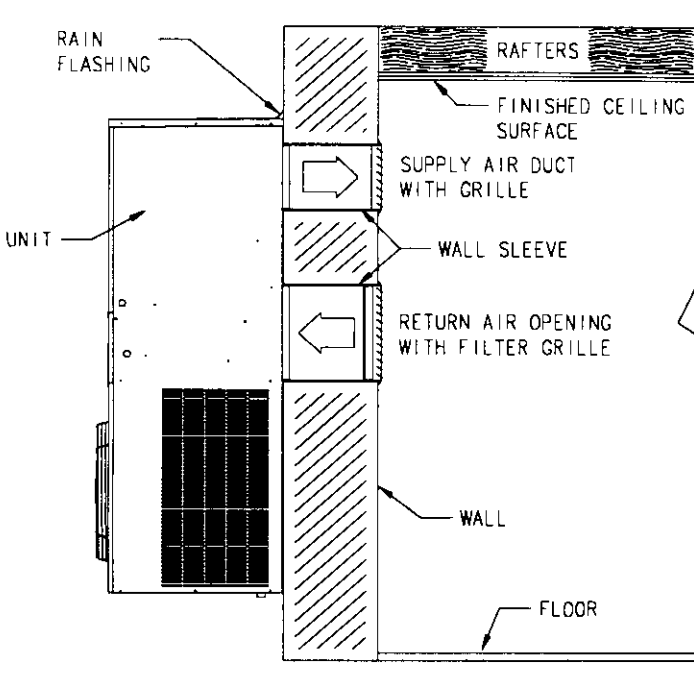

MIS-1152

DUCTED SUPPLY WITH RETURN AT UNIT

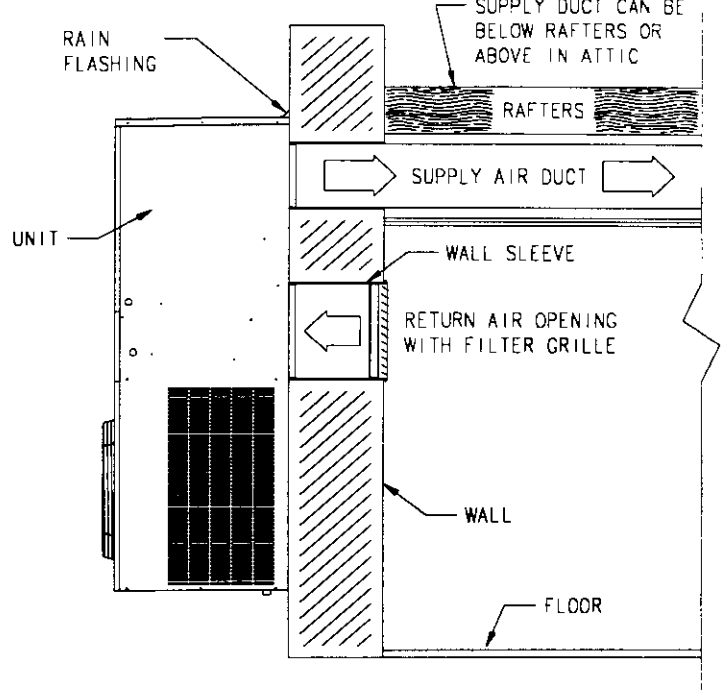

MIS-1153

FALSE WALL INSTALLATION

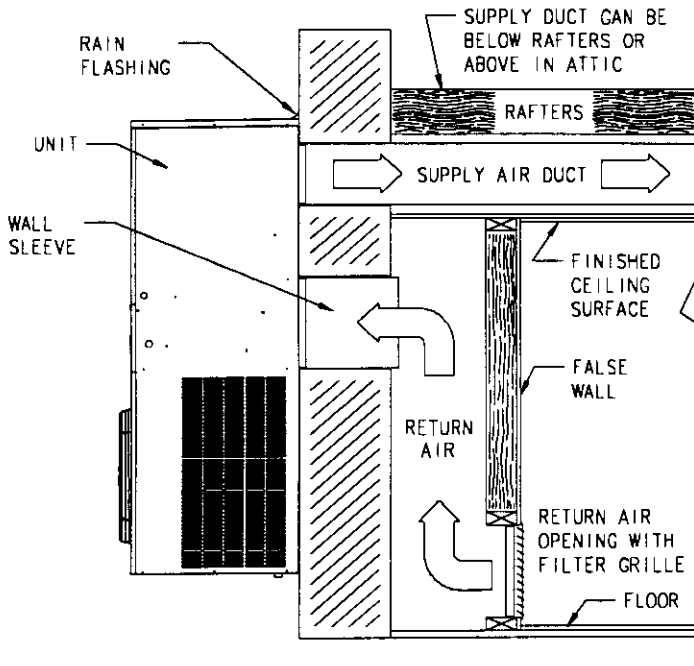

MIS-1154

CLOSET INSTALLATION

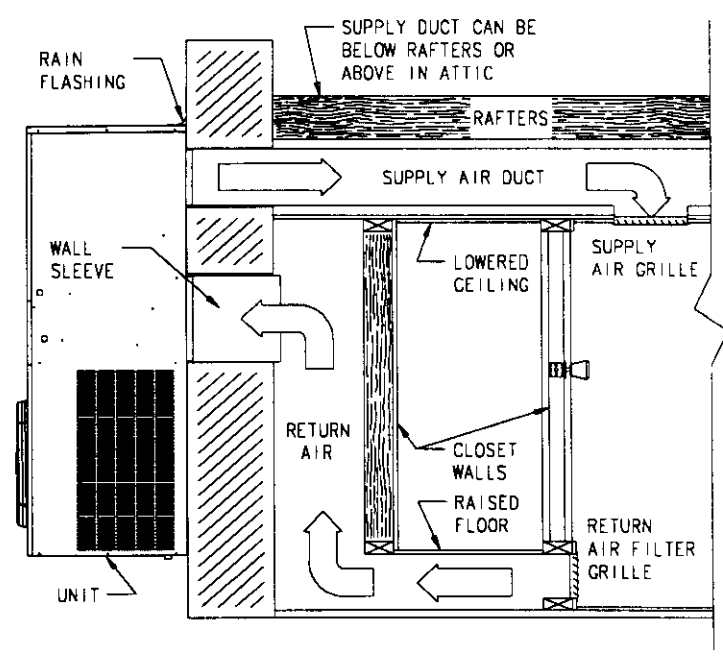

MIS-1155

Four (4) wires should be run from thermostat subbase to the 24V terminal board in the unit. A four conductor, 18 gauge copper, color coded thermostat cable is recommended. The connection points are shown in Figure 5 on Page 10.

TABLE 3 – THERMOSTAT WIRE SIZE

Transformer VA	FLA	Wire Gauge	Maximum Distance In Feet
55	2.3	20 gauge	45
		18 gauge	60
		16 gauge	100
		14 gauge	160
		12 gauge	250

TABLE 4 – WALL THERMOSTAT AND SUBBASE COMBINATIONS

Thermostat	Subbase	Predominate Features
8403-002 T87F311	8404-003 Q539A1220	1 stage heat, 1 stage cool; Mercury System: heat-off-cool Fan: on-auto
8403-041 T8034-C	---	1 stage heat, 1 stage cool; Mercury System: heat-off-cool Fan: on-auto
8403-035 1F95-80	---	2 stage heat, 2 stage cool Programmable Electronic
8403-042 T8511G	---	2 stage heat, 1 stage cool System: heat-off-auto-cool Fan: on-auto Electronic
8403-043 CM200	---	1 stage heat, 1 stage cool System: heat-off-cool Fan: on-auto Snap Action

FIGURE 5 - LOW VOLTAGE WIRING

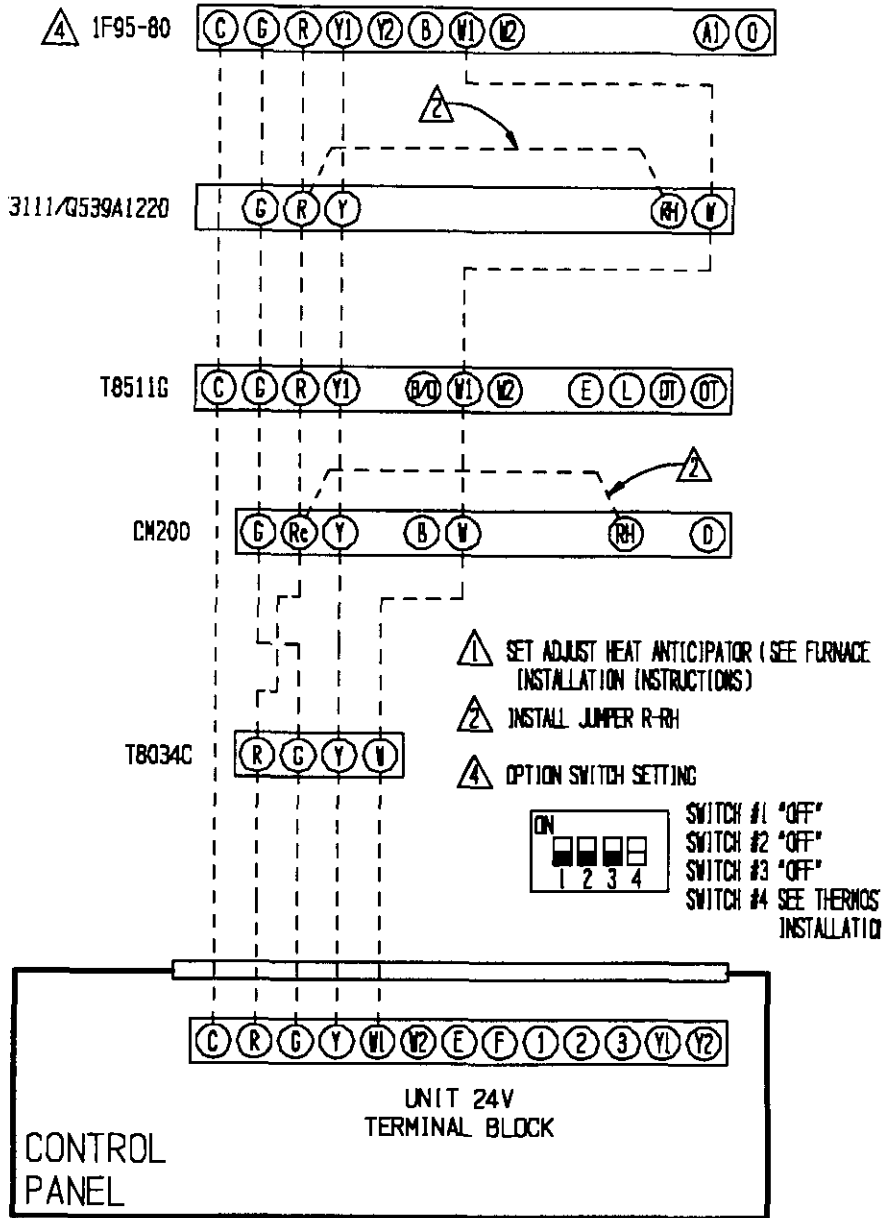

HOW TO SET AN ADJUSTABLE ANTICIPATOR

The primary purpose of the adjustable anticipator thermostat is to provide a single thermostat to match almost any type of primary control in the field today. Refer to thermostat instructions for details on thermostat set up.

The adjustable heat anticipator has a slide wire adjustment with the point scale marked in tenths of an ampere. This is used to set the anticipator to agree with the control amp draw of the control system in use. Refer to Figure 6.

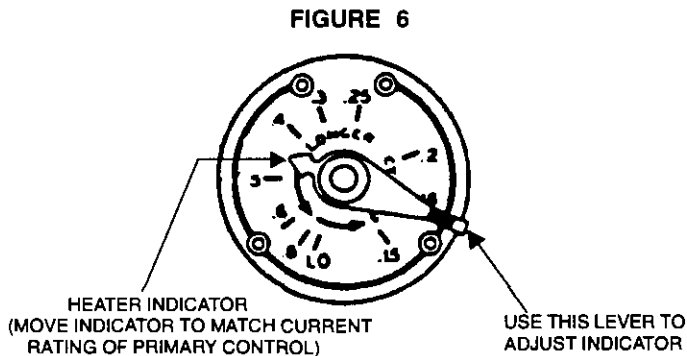

OR

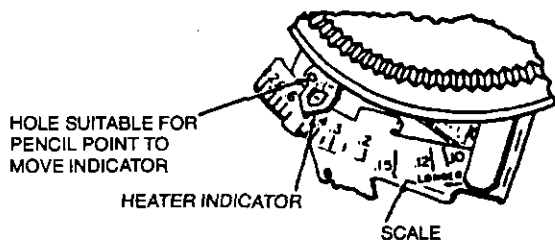

If the primary control nameplate has no rating or if further adjustment is necessary, use the following procedure to determine the current draw of each stage:

The current draw of each heating stage must be measured with the thermostat removed and the power on.

1. Connect an AC ammeter of appropriate range between the heating terminals of the subbase.
 Stage 1 – between W1 and RH or R
 Stage 2 – between W2 and RH or R
2. Move the system switch to *HEAT* or *AUTO*.
3. After one minute, read the ammeter and record the reading.
4. After mounting the thermostat, set the adjustable heat anticipator(s) to match the respective reading(s) measured in Step 3.

If you want to change the cycle of the heating system you can make a simple adjustment on the anticipator to do this.

Additional adjustment, if necessary, may be made as follows:

Heater cycles too short – set adjustable heater to a slightly higher dial setting (1/2 division).

Heater cycles too long – set adjustable heater to a slightly lower dial setting (1/2 division).

Occasionally you may find a system where longer or shorter cycles of the primary control are desirable. If the primary control draws .45 amps and you want a longer cycle, set the anticipator to .5 or .6 amps. This puts *less* resistance in the circuit. With less resistance, but the same current (from the primary control), you will generate less “false” heat and get a longer cycle of the primary control.

If a setting .45 amps on the adjustable anticipator gives a cycle that is longer than desired, reset the indicator to .3 or .25 amps. This will put *more* resistance in the circuit and thus generate more “false” heat for shorter cycle.

ADDITIONAL INFORMATION FOR ELECTRIC HEAT OR HEAT PUMP APPLICATIONS

Adjust heat anticipator to match current rating of heating relay for W1 (and W2 if 2 stage). Move indicator on the scale to correspond with this current rating.

If the current rating is not given, proceed as follows:

1. Wrap exactly 10 loops of thermostat wire (W1) around the prongs of an Amprobe. (See Figure 7.)
2. Let the heating system operate for one minute before reading the W1 or W2 current draw.
3. Divide the reading obtained in Step 2 by 10.
4. Use the value calculated in Step 3 to set the heat.
5. Repeat the procedure for W2 if 2 stage heat anticipator.

Example: $\frac{6.0 \text{ Amp}}{10 \text{ loops}} = .6A$

FIGURE 7

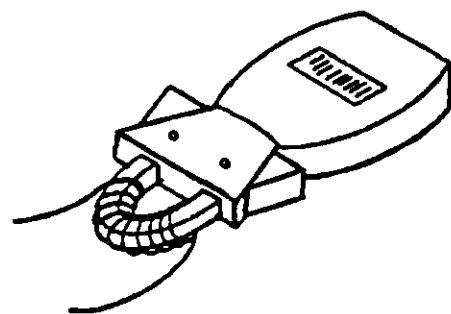

NOTE: Cooling anticipators on all thermostat are fixed and do not require setting.

START-UP

IMPORTANT INSTALLER NOTE

For improved start-up performance, wash the indoor coil with a dish detergent.

SERVICE HINTS

1. Caution building owner/operator to maintain clean air filters at all times; also not to needlessly close off supply and return air registers. This reduces air flow through the system which shortens equipment service life as well as increasing operating costs.
2. Check all power fuses or circuit breakers to be sure they are the correct rating.
3. Periodic cleaning of the outdoor coil to permit full and unrestricted airflow circulation is essential.

SEQUENCE OF OPERATION

COOLING

Circuit R-Y makes at thermostat pulling in compressor contactor, starting the compressor and outdoor motor. The G (indoor motor) circuit is automatically completed on any call for cooling operation or can be energized by manual fan switch on subbase for constant air circulation. On a call for heating, circuit R-W1 make at the thermostat pulling in heat contact for the strip heat and blower operation.

All models are equipped with a two speed outdoor fan which is controlled by an outdoor thermostat. When the outdoor conditions are above 90° F, the fan will run on high speed. Below 90° F the fan will run on low speed.

COMPRESSOR CONTROL MODULE

All models are equipped with a compressor control module. This control is an anti-short cycle/lockout timer with high and low pressure switch monitoring and alarm relay output.

MODE OF OPERATION

Delay on Make Timer

- On a call for cooling the delay on make period begins (adjustable from 30-180 seconds).
- When the delay on make is complete, and the high pressure switch is closed, the compressor contactor is energized.

High Pressure Switch and Lockout Sequence

- If the high pressure switch opens, the compressor contactor will de-energize immediately. The lockout timer will go into a soft lockout and stay in soft lockout until the high pressure switch closes and the delay on make time has expired.
- If the high pressure switch opens again in this same operating cycle the unit will go into manual lockout condition and the alarm relay circuit will energize.
- Recycling the wall thermostat resets the manual lockout.

Low Pressure Switch, Bypass and Lockout Sequence

- If the low pressure switch opens for more than 120 seconds, the compressor contactor will de-energize and go into a soft lockout.
- Regardless the state of the low pressure switch, the contactor will re-energize after the delay on make time delay has expired.
- If the low pressure switch remains open, or opens again for longer than 120 seconds the unit will go into manual lockout condition and the alarm relay circuit will energize.
- Recycling the wall thermostat resets the manual lockout.

NOTE: Both high and low pressure switch controls are inherently automatic reset devices. The high pressure switch opens at 425 and closes at 325 psig, and the low pressure switch opens at 14 and closes at 30 psig. The lockout features, both soft and manual, are a function of the Compressor Safeguard Control.

All models are equipped with a low ambient fan cycling control for low ambient operation. Down to 0° F, the fan cycling control will turn on the fan at 280 psig discharge pressure and turn off the fan at 180 psig discharge pressure.

PRESSURE SERVICE PORTS

High and low pressure service ports are installed on all units so that the system operating pressures can be observed. Pressure curves can be found later in the manual covering all models. It is imperative to match the correct pressure curve to the unit by model number.

TROUBLE SHOOTING

FAN BLADE SETTING DIMENSIONS

Shown in the drawing below are correct fan blade setting dimensions for proper air delivery across the outdoor coil.

Any service work requiring removal or adjustment in the fan and/or motor area will require that the dimensions below be checked and blade adjusted in or out on the motor shaft accordingly.

FIGURE 8 – FAN BLADE SETTING DIMENSIONS

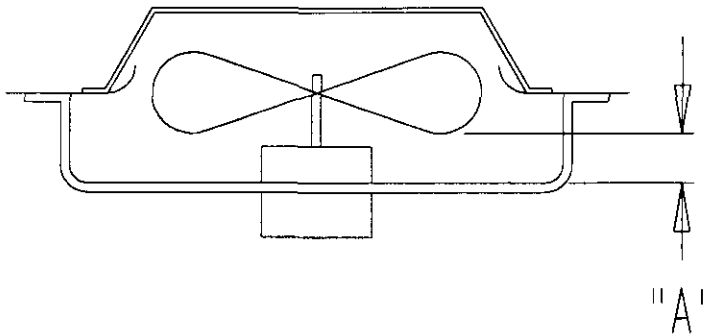

TABLE 5

Model	Dimension A
CT241	1.00

TABLE 6

INDOOR BLOWER PERFORMANCE – CFM @ 230V

No return filter grille or filter				
E.S.P.	Medium Speed Dry	Medium Speed Wet	High Speed Dry	High Speed Wet
0.0.	1,012	980	1,070	1,038
0.1	925	893	982	950
0.2	859	827	924	892
0.3	794	763	855	823
0.4	722	690	775	743
0.5	642	610	694	662
0.6	537	505	598	566
With return filter grille and 1" washable filter				
E.S.P.	Medium Speed Dry	Medium Speed Wet	High Speed Dry	High Speed Wet
0.0.	847	815	880	848
0.1	760	728	792	760
0.2	694	662	734	702
0.3	629	597	665	633
0.4	557	525	585	553
0.5	477	445	504	472
0.6	372	340	408	376

NOTE: Reduce airflow by 30 CFM for 208V operation.

TABLE 7

MAXIMUM ESP OF OPERATION ELECTRIC HEAT ONLY

Model	ESP
ALL	.60

TABLE 8

COOLING

Air Temperature Entering Outdoor Coil Degree °F

Model	Return Air Temperature	Pressure	75	80	85	90	95	100	105	110	115
CT241	75 deg. DB 62 deg. WB	Low Side	70	71	73	74	75	76	77	78	79
		High Side	215	230	246	262	281	300	320	342	364
	80 deg. DB 67 deg. WB	Low Side	75	76	77	78	79	80	81	82	83
		High Side	220	235	252	269	288	307	328	350	373
	85 deg. DB 72 deg. WB	Low Side	81	82	83	84	85	86	87	88	89
		High Side	229	244	261	279	298	318	340	362	386

Low side pressure ± 2 PSIG
High side pressure ± 5 PSIG

Tables are based upon rated CFM (airflow) across the evaporator coil. If there is any doubt as to correct operating charge being in the system, the charge should be removed, system evacuated, and recharged to serial plate instructions.

240/208-60-1

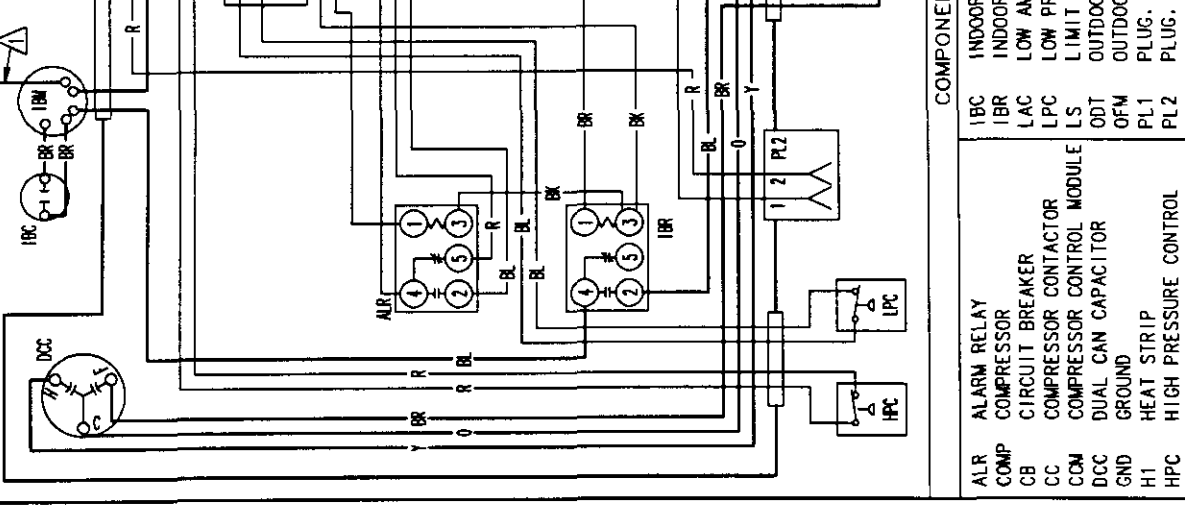
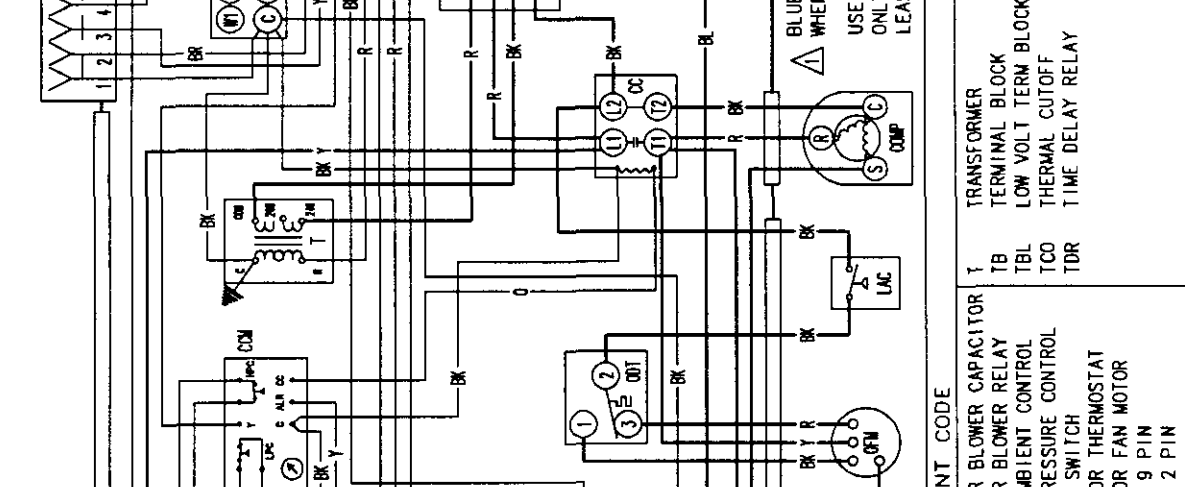
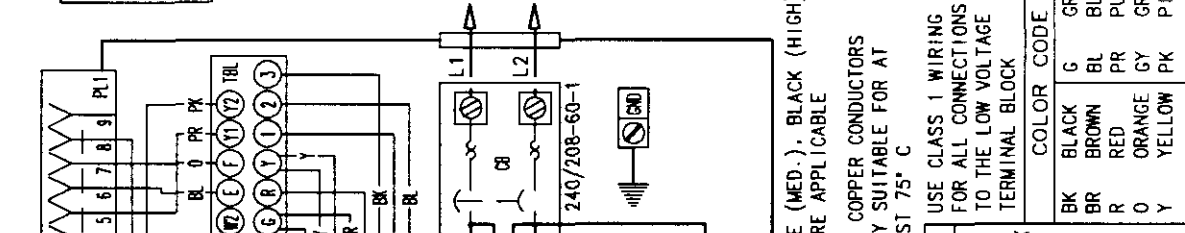
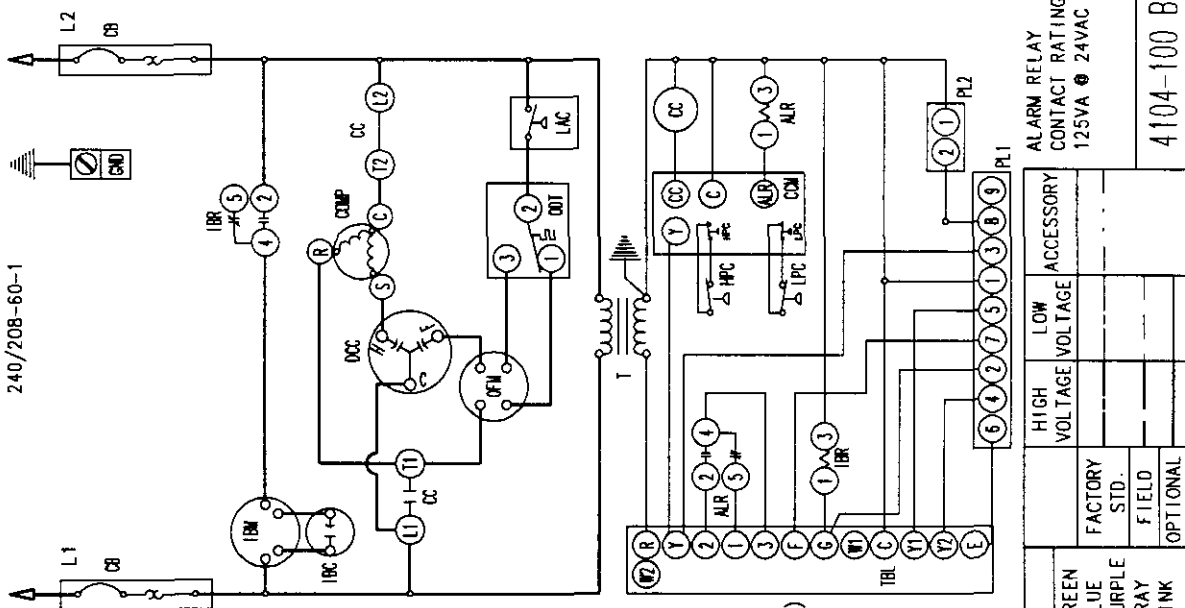

COMPONENT CODE	
ALR	ALARM RELAY
COMP	COMPRESSOR
CB	CIRCUIT BREAKER
CC	COMPRESSOR CONTROL
CCM	COMPRESSOR CONTROL MODULE
DCC	DUAL CAN CAPACITOR
GND	GROUND
H1	HEAT STRIP
HPC	HIGH PRESSURE CONTROL
IBC	INDOOR BLOWER CAPACITOR
IBR	INDOOR BLOWER RELAY
LAC	LOW AMBIENT CONTROL
LPC	LOW PRESSURE CONTROL
LS	LIMIT SWITCH
ODT	OUTDOOR THERMOSTAT
OFM	OUTDOOR FAN MOTOR
PL1	PLUG, 9 PIN
PL2	PLUG, 2 PIN
T	TRANSFORMER
TB	TERMINAL BLOCK
TCC	LOW VOLT TERM BLOCK
TDR	THERMAL CUTOFF
TDR	TIME DELAY RELAY

USE CLASS 1 WIRING FOR ALL CONNECTIONS TO THE LOW VOLTAGE TERMINAL BLOCK

COLOR CODE	HIGH VOLTAGE	LOW VOLTAGE	ACCESSORY
BK	BLACK	BLACK	
BR	BROWN	BROWN	
R	RED	RED	
O	ORANGE	ORANGE	
Y	YELLOW	YELLOW	
G	GREEN	GREEN	
BL	BLUE	BLUE	
PR	PURPLE	PURPLE	
GY	GRAY	GRAY	
PK	PINK	PINK	

BLUE (MED.), BLACK (HIGH) WHERE APPLICABLE

USE COPPER CONDUCTORS ONLY SUITABLE FOR AT LEAST 75° C

ALARM RELAY CONTACT RATINGS
125VA @ 24VAC

4104-100 B

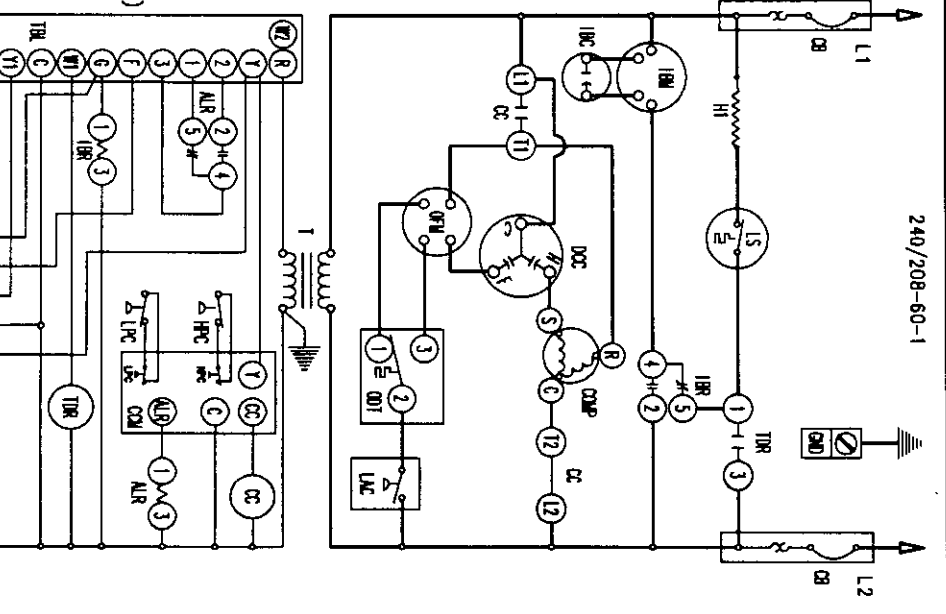
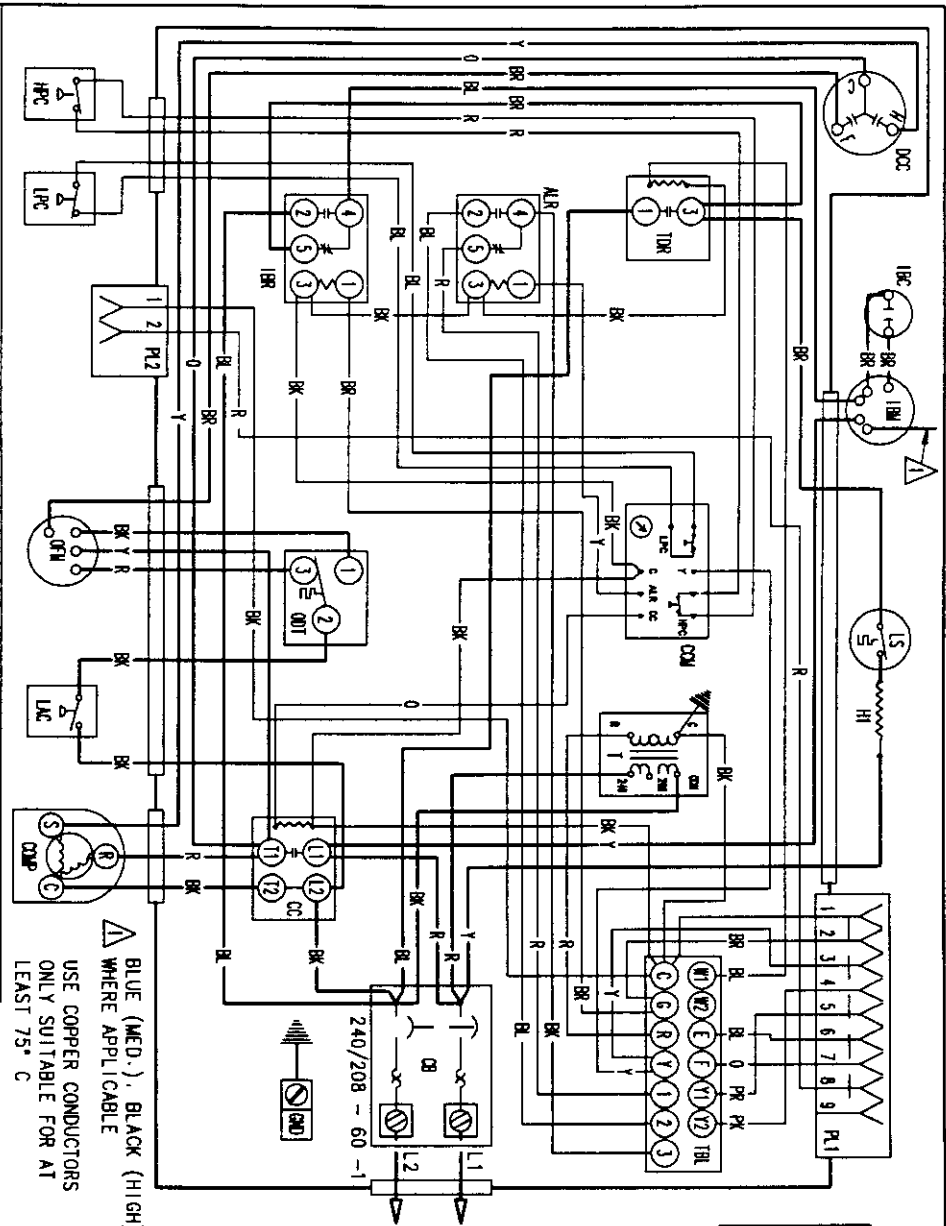

COMPONENT CODE		COLOR CODE		ALARM RELAY CONTACT RATINGS	
ALR	ALARM RELAY	BK	BLACK	HIGH	125VA
COMP	COMPRESSOR	BR	BROWN	LOW	24VAC
CB	CIRCUIT BREAKER	R	RED	ACCESSORY	
CC	COMPRESSOR CONTACTOR	GY	GRAY		
CCM	COMPRESSOR CONTROL MODULE	PK	PINK		
DCC	DUAL CAN CAPACITOR				
GND	GROUND				
H1	HEAT STRIP				
HPC	HIGH PRESSURE CONTROL				
IBC	INDOOR BLOWER CAPACITOR				
IBR	INDOOR BLOWER RELAY				
LAC	LOW AMBIENT CONTROL				
LPC	LOW PRESSURE CONTROL				
LS	LIMIT SWITCH				
OFM	OUTDOOR FAN MOTOR				
ODT	OUTDOOR THERMOSTAT				
PL1	PLUG, 9 PIN				
PL2	PLUG, 2 PIN				
T	TRANSFORMER				
TB	TERMINAL BLOCK				
TBL	LOW VOLT TERM BLOCK				
TCC	THERMAL CUTOFF				
TDR	TIME DELAY RELAY				

USE CLASS 1 WIRING FOR ALL CONNECTIONS TO THE LOW VOLTAGE TERMINAL BLOCK

USE COPPER CONDUCTORS ONLY SUITABLE FOR AT LEAST 75° C

BLUE (MED.), BLACK (HIGH) WHERE APPLICABLE

4104-110 B

240/208-60-1

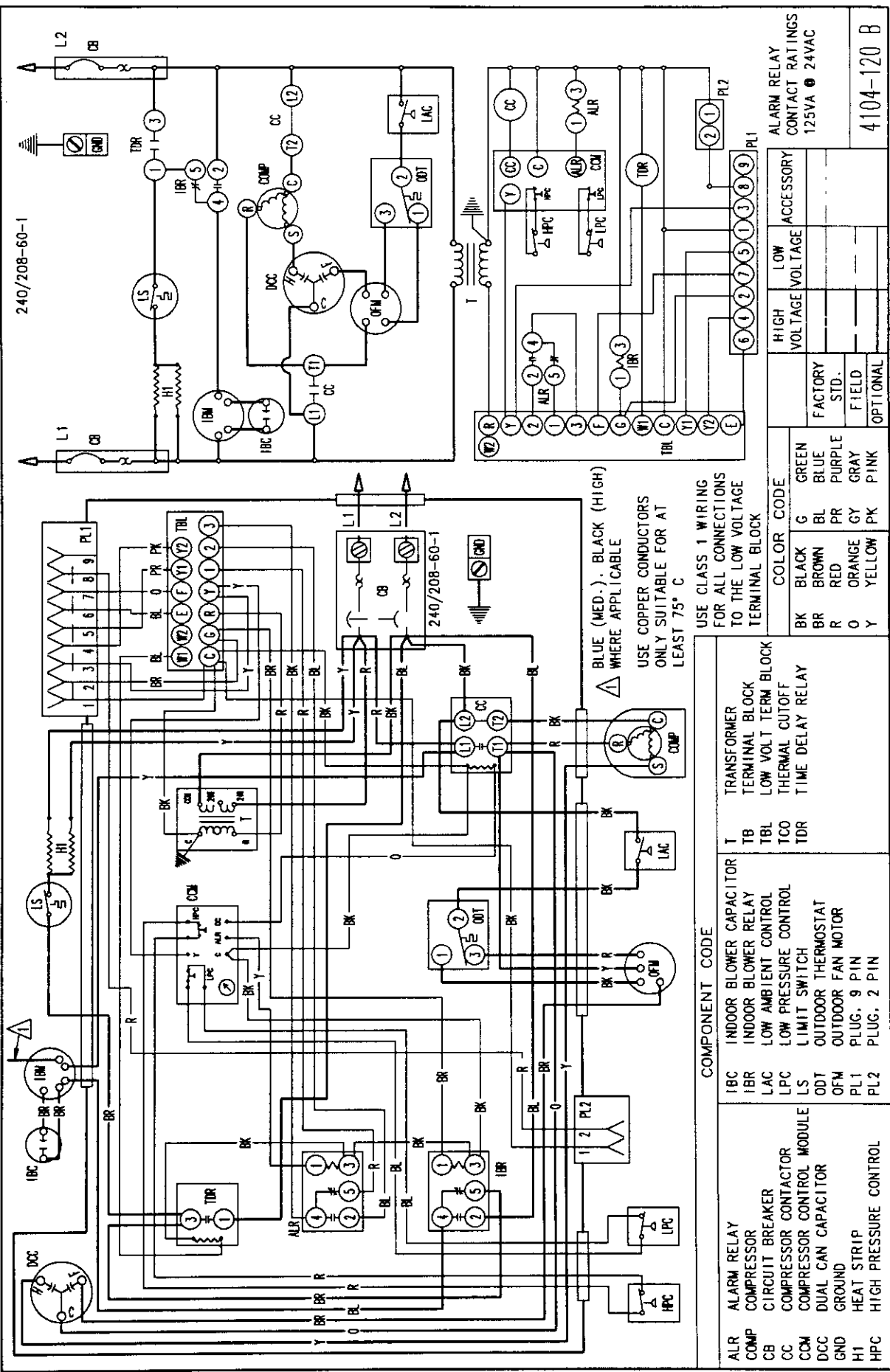

BLUE (MED.), BLACK (HIGH)
WHERE APPLICABLE
USE COPPER CONDUCTORS
ONLY SUITABLE FOR AT
LEAST 75° C

USE CLASS 1 WIRING
FOR ALL CONNECTIONS
TO THE LOW VOLTAGE
TERMINAL BLOCK

COMPONENT CODE		COLOR CODE	
ALR	ALARM RELAY	BK	BLACK
COMP	COMPRESSOR	BR	BROWN
CB	CIRCUIT BREAKER	R	RED
CC	COMPRESSOR CONTACTOR	O	ORANGE
CCM	COMPRESSOR CONTROL MODULE	Y	YELLOW
DCC	DUAL CAN CAPACITOR	G	GREEN
GND	GROUND	BL	BLUE
H1	HEAT STRIP	PR	PURPLE
HPC	HIGH PRESSURE CONTROL	GY	GRAY
IBC	INDOOR BLOWER CAPACITOR	PK	PINK
IBR	INDOOR BLOWER RELAY		
LAC	LOW AMBIENT CONTROL		
LPC	LOW PRESSURE CONTROL		
LS	LIMIT SWITCH		
ODT	OUTDOOR THERMOSTAT		
OFM	OUTDOOR FAN MOTOR		
PL1	PLUG, 9 PIN		
PL2	PLUG, 2 PIN		
T	TRANSFORMER		
TB	TERMINAL BLOCK		
TBL	LOW VOLT TERM BLOCK		
TCC	THERMAL CUTOFF		
TDR	TIME DELAY RELAY		

HIGH VOLTAGE	LOW VOLTAGE	ACCESSORY
1	1	1
2	2	2
3	3	3
4	4	4
5	5	5
6	6	6
7	7	7
8	8	8
9	9	9

ALARM RELAY CONTACT RATINGS
125VA @ 24VAC
4104-120 B

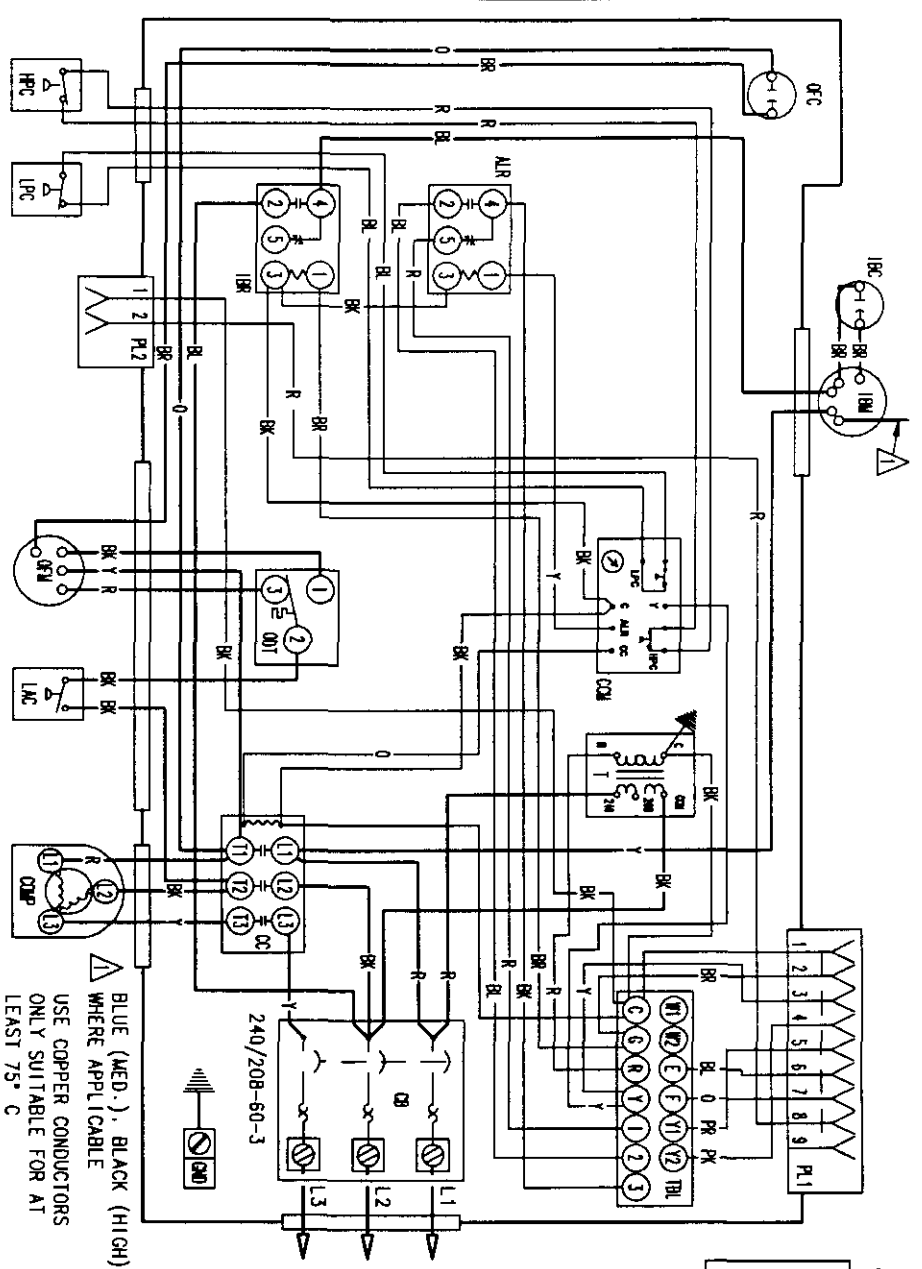

COMPONENT CODE

ALR	ALARM RELAY	IBC	INDOOR BLOWER CAPACITOR	T	TRANSFORMER
COMP	COMPRESSOR	IBR	INDOOR BLOWER RELAY	TB	TERMINAL BLOCK
CB	CIRCUIT BREAKER	LAC	LOW AMBIENT CONTROL	TBL	LOW VOLT TERM BLOCK
CC	COMPRESSOR CONTROL	LPC	LOW PRESSURE CONTROL	TCO	THERMAL CUTOFF
CCM	COMPRESSOR CONTROL MODULE	LS	LIMIT SWITCH	TDR	TIME DELAY RELAY
DCC	DUAL CAN CAPACITOR	ODT	OUTDOOR THERMOSTAT		
GND	GROUND	OFM	OUTDOOR FAN MOTOR		
H1	HEAT STRIP	PL1	PLUG, 9 PIN		
HPC	HIGH PRESSURE CONTROL	PL2	PLUG, 2 PIN		

BLUE (MED.), BLACK (HIGH)
WHERE APPLICABLE
USE COPPER CONDUCTORS
ONLY SUITABLE FOR AT
LEAST 75° C

USE CLASS 1 WIRING
FOR ALL CONNECTIONS
TO THE LOW VOLTAGE
TERMINAL BLOCK

COLOR CODE	
BK	BLACK
BR	BROWN
R	RED
O	ORANGE
Y	YELLOW
G	GREEN
BL	BLUE
PR	PURPLE
GY	GRAY
PK	PINK

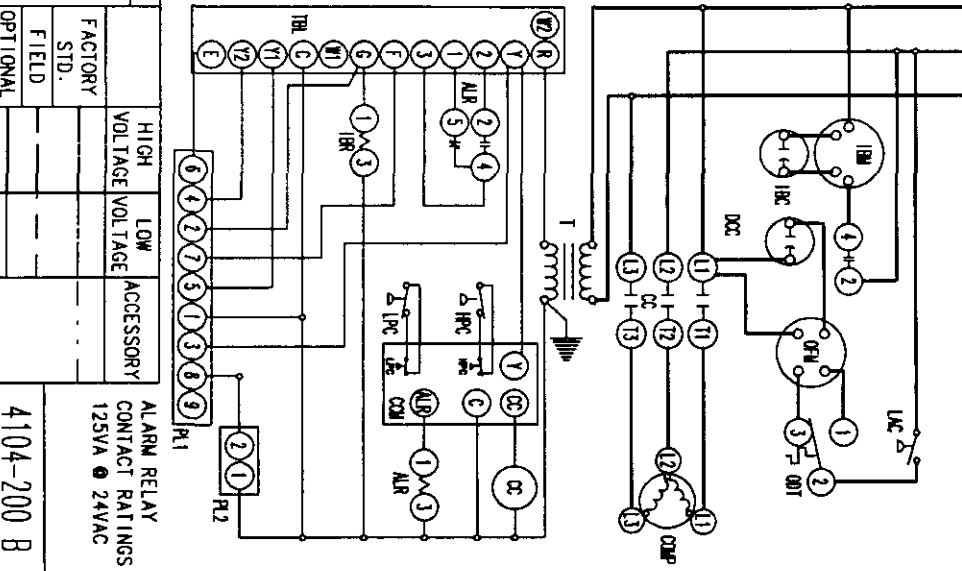
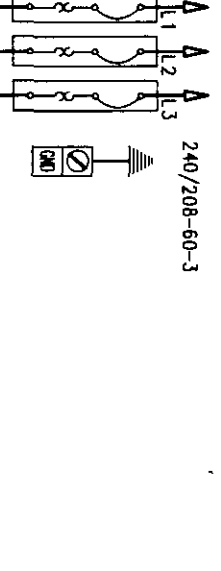

FACTORY		ACCESSORY	
VOLTAGE		VOLTAGE	
HIGH	LOW	HIGH	LOW
240	208	240	208
60	60	60	60
3	3	3	3
ALARM RELAY CONTACT RATINGS		ALARM RELAY CONTACT RATINGS	
125VA @ 24VAC		125VA @ 24VAC	

4104-200 B

240/208-60-3

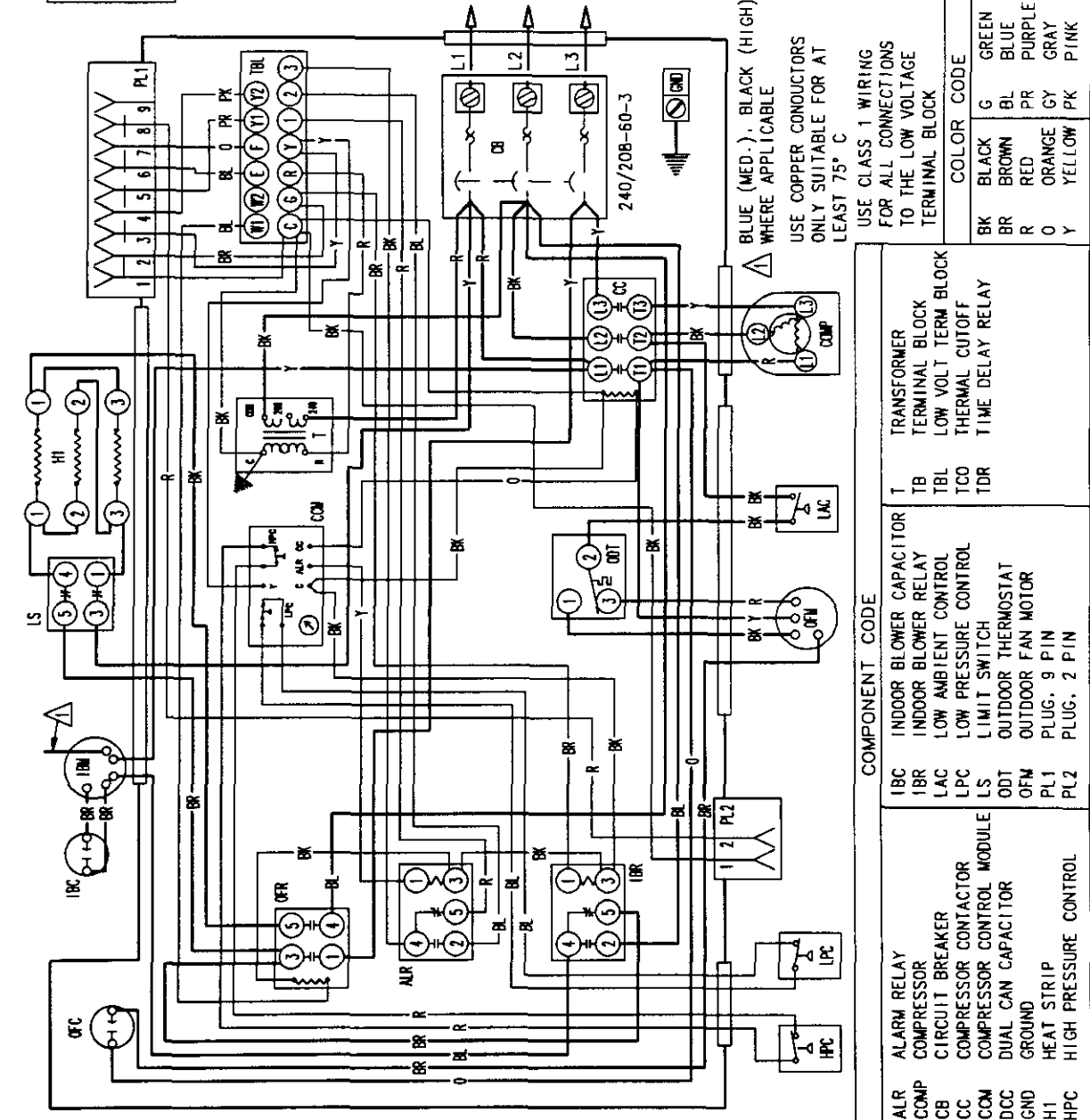
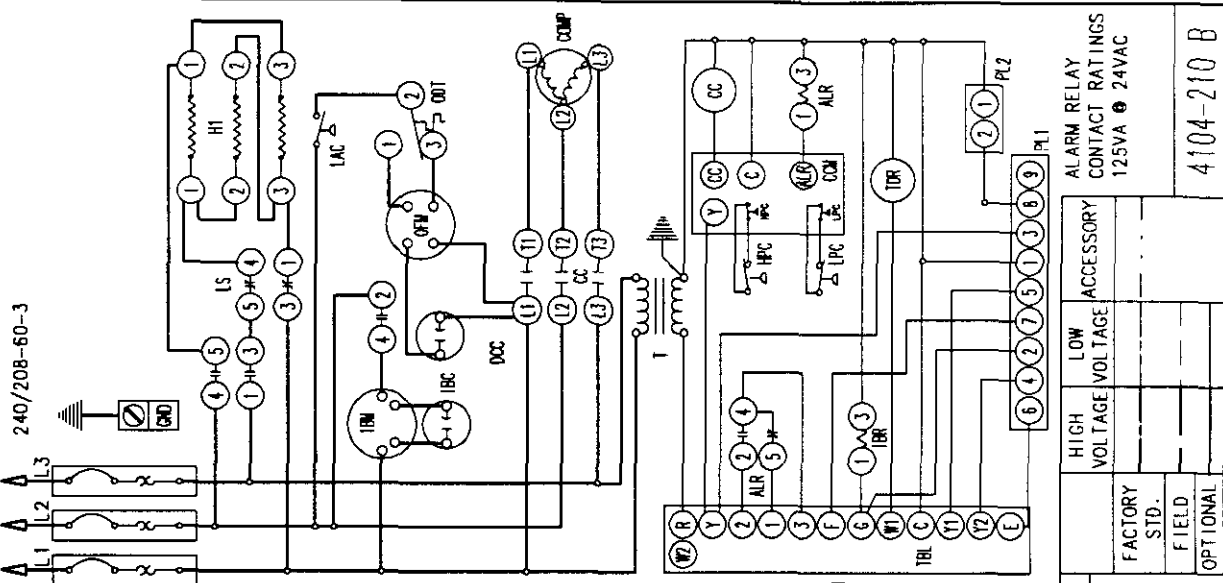

BLUE (MED.), BLACK (HIGH)
WHERE APPLICABLE
USE COPPER CONDUCTORS
ONLY SUITABLE FOR AT
LEAST 75° C

USE CLASS 1 WIRING
FOR ALL CONNECTIONS
TO THE LOW VOLTAGE
TERMINAL BLOCK

COLOR CODE	
BK	BLACK
BR	BROWN
R	RED
O	ORANGE
Y	YELLOW
G	GREEN
BL	BLUE
PR	PURPLE
GY	GRAY
PK	PINK

COMPONENT CODE	
IBR	INDOOR BLOWER RELAY
IBR	INDOOR BLOWER RELAY
LAC	LOW AMBIENT CONTROL
LPC	LOW PRESSURE CONTROL
LS	LIMIT SWITCH
ODT	OUTDOOR THERMOSTAT
OFM	OUTDOOR FAN MOTOR
PL1	PLUG, 9 P IN
PL2	PLUG, 2 P IN

COMPONENT CODE	
ALR	ALARM RELAY
COMP	COMPRESSOR
CB	CIRCUIT BREAKER
CC	COMPRESSOR CONTACTOR
CCM	COMPRESSOR CONTROL MODULE
DCC	DUAL CAN CAPACITOR
GND	GROUND
H1	HEAT STRIP
HPC	HIGH PRESSURE CONTROL

HIGH VOLTAGE	LOW VOLTAGE	ACCESSORY

FACTORY STD.	FIELD	OPTIONAL

ALARM RELAY CONTACT RATINGS
125VA @ 24VAC

4104-210 B

