

INSTALLATION INSTRUCTIONS

WATER SOURCE HEAT PUMPS

MODELS: **GSVS241-A, GSVS301A
GSVS361-A, GSVS421-A**

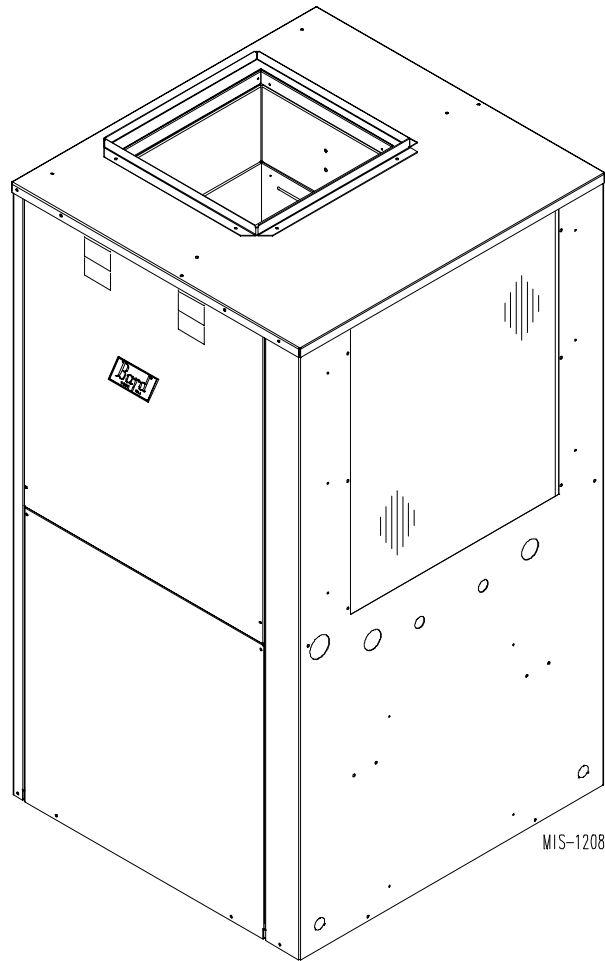

**Earth Loop Fluid
Temperatures 25° - 110°
Ground Water Temperatures 45° - 75°**



BARD MANUFACTURING COMPANY

Bryan, Ohio 43506

Since 1914...Moving ahead, just as planned.

Manual: 2100-317B
Supersedes: 2100-317A
File: Volume I, Tab 8
Date: 02-10-2000

Contents

Getting Other Informations and Publications	1	Open Loop (Well System Applications)	
General Information		Note	20
Water Source Nomenclature	2	Water Connection	20
Heater Package Nomenclature	5	Well Pump Sizing	20
Application and Location		Start Up Prodecure for Open Loop System	22
General	6	Water Corrosion	22
Shipping Damage	6	Remedies of Water Problems	23
Application	6	Lake and/or Pond Installations	24
Location	6	Sequence of Operation	
Ductwork	6	Cooling	25
Filters	8	Heating Without Electric Heat	25
Condensate Drain	8	Heating With Electric Heat	25
Piping Access to Unit	8	Emergency Heat	25
Wiring Instructions		Lockout Circuits	25
General	9	Pressure Service Ports	25
Control Circuit Wiring	9	System Start Up	25
Wall Thermostats	9	Pressure Tables	28
Thermostat Indicator Lamps	10	Quick Reference Troubleshooting Chart	29
Emergency Heat Position	10	Service	
Blower Control Setup	10	Service Hints	30
Humidity Control	10	Unbrazing System Components	30
CFM Light	10	Troubleshooting ECM Blower Motors	31-32
Wiring Diagrams	12-16	Accessories	
Closed Loop (Earth Coupled Groung Loop Applications)		Add-On DPM26A Pump Module Kit	33
Note	17	General	33
Circulation System Design	17	Installation	33
Start Up Procedure for Closed Loop System	18	Ground Source Heat Pump Performance Report	34-35
		Wiring Diagram	36

Figures

Figure 1 Unit Dimensions	4
Figure 2 Field-Conversion to Left Hand Return	7
Figure 3 Filter Components	8
Figure 4 Piping Access	8
Figure 5 Blower Control Board	11
Figure 6 Circulation System Design	17
Figure 7	18
Figure 8 Performance Model GPM-1 Loop Pump Module	19
Figure 9 Performance Model GPM-2 Loop Pump Module	19
Figure 10 Water Connection Components	21
Figure 11 Cleaning Water Coil	22
Figure 12 Lake or Pond Installation	24
Figure 13	26
Figure 14 Control Board	26
Figure 15	27
Figure 16 Pressure Tables	28
Figure 17 DPM26A Pump and GSVS Unit	33

Tables

Table 1 Specifications	2
Table 2 Indoor Blower Performance	3
Table 2A Flow Rates for Various Fluids	3
Table 3 Water Coil Pressure Drop	3
Table 4 Electrical Specifications Optional Field Installed Heater Package	5
Table 5 Control Circuit Wiring	9
Table 6 Wall Thermostat and Subbase Combinations	9
Table 7 Proper Location of Taps	10
Table 8 Constant Flow Valves	20

Getting Other Information and Publications

These publications can help you install the air conditioner or heat pump. You can usually find these at your local library or purchase them directly from the publisher. Be sure to consult current edition of each standard.

National Electrical Code ANSI/NFPA 70

Standard for the Installation ANSI/NFPA 90A
of Air Conditioning and
Ventilating Systems

Standard for Warm Air ANSI/NFPA 90B
Heating and Air
Conditioning Systems

Load Calculation for Residential ACCA Manual J
Winter and Summer
Air Conditioning

Duct Design for Residential ACCA Manual D
Winter and Summer Air Conditioning
and Equipment Selection

Closed-Loop/Ground Source Heat Pump IGSHPA
Systems Installation Guide

Grouting Procedures for Ground-Source IGSHPA
Heat Pump Systems

Soil and Rock Classification for the Design IGSHPA
of Ground-Coupled Heat Pump Systems

Ground Source Installation Standards IGSHPA

Closed-Loop Geothermal Systems – Slinky IGSHPA
Installation Guide

For more information, contact these publishers:

ACCA **Air Conditioning Contractors of America**
1712 New Hampshire Avenue
Washington, DC 20009
Telephone: (202) 483-9370
Fax: (202) 234-4721

ANSI **American National Standards Institute**
11 West Street, 13th Floor
New York, NY 10036
Telephone: (212) 642-4900
Fax: (212) 302-1286

ASHRAE **American Society of Heating Refrigerating,
and Air Conditioning Engineers, Inc.**
1791 Tullie Circle, N.E.
Atlanta, GA 30329-2305
Telephone: (404) 636-8400
Fax: (404) 321-5478

NFPA **National Fire Protection Association**
Batterymarch Park
P.O. Box 9101
Quincy, MA 02269-9901
Telephone: (800) 344-3555
Fax: (617) 984-7057

IGSHPA **International Ground Source
Heat Pump Association**
490 Cordell South
Stillwater, OK 74078-8018

WATER SOURCE PRODUCT LINE NOMENCLATURE

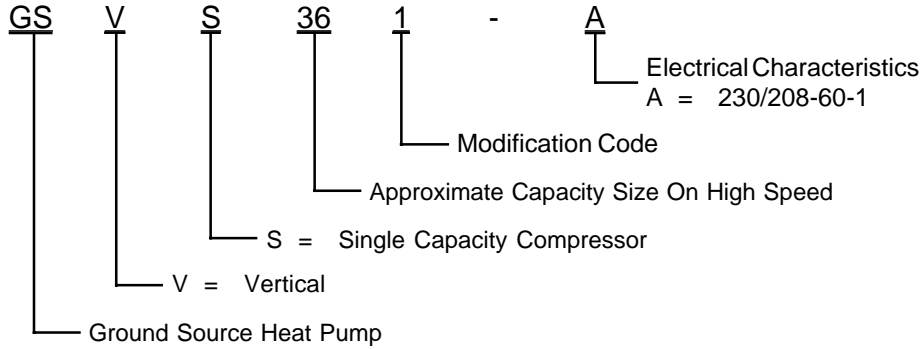

**TABLE 1
SPECIFICATIONS**

MODEL	GSVS241-A	GSVS301-A	GSVS361-A	GSVS421-A
Electrical Rating (60Z/VPH)	230/208-1	230/208-1	230/208-1	230/208-1
Operating Voltage Range	253-197	253-197	253-197	253-197
Minimum Circuit Ampacity	13.0	16.0	20.0	24.0
+ Field Wire Size	#14	#14	#12	#10
++ Delay Fuse Max or Circuit Breaker	20	25	30	35
Total Unit Amps 230/208	8.2 / 9.4	11.0 / 12.0	13.9 / 14.5	17.7 / 19.1
COMPRESSOR				
Volts	230/208	230/208	230/208	230/208
Rated Load Amps 230/208	6.6 / 7.8	8.7 / 9.7	11.0 / 11.6	14.2/15.6
Branch Circuit Selection Current	8.4	10.3	13.5	16.0
Lock Rotor Amps 230/208	17 / 47	56 / 56	72.5 / 72.5	88 / 88
BLOWER MOTOR and EVAPORATOR				
Blower Motor HP / Spd.	1/2 / Variable			
Blower Motor Amps / CFM	1.6 / 800	2.3 / 1000	2.9 / 1200	3.5 / 1250
Face Area Sq. Ft./Rows/Fins Per Inch	3.16 / 3 / 15	3.16 / 3 / 15	3.16 / 4 / 11	3.16 / 4 / 11

+ 75°C copper wire

++ HACR type circuit breaker

**TABLE 2
INDOOR PLOWER PERFORMANCE (CFM)**

Model	GSVS241-A	GSVS301-A	GSVS361-A	GSVS421-A
ESP Inches WC				
.00	800	1000	1200	1250
.10	800	1000	1200	1250
.20	800	1000	1200	1250
.30	800	1000	1200	1250
.40	800	1000	1200	1250
.50	800	1000	1200	1250
.60	800	1000	1200	1250

ESP = External Static Pressure (Inches of water)

**TABLE 2A
FLOW RATES FOR VARIOUS FLUIDS**

VARIOUS FLUIDS	MODELS			
	GSVS241-A	GSVS301-A	GSVS361-A	GSVS421-A
Flow rate required GPM fresh water	3	4	5	5
Flow rate required GPM 15% Sodium Chloride	5	6	7	8
Flow rate required GPM 25% GS4	5	6	7	8

**TABLE 3
WATER COIL PRESSURE DROP**

Model	GSVS241		GSVS301		GSVS361, GSVS421	
	GPM	PSIG	Ft. Hd.	PSIG	Ft. Hd.	PSIG
3	1.00	2.31	---	---	---	---
4	1.42	3.28	1.00	2.31	---	---
5	1.83	4.22	1.43	3.30	1.80	4.15
6	2.24	5.17	1.86	4.29	3.28	7.57
7	2.66	6.14	2.30	5.31	4.77	11.01
8	---	---	2.73	6.30	6.26	14.46
9	---	---	---	---	7.75	17.90
10	---	---	---	---	9.24	21.34
11	---	---	---	---	---	---
12	---	---	---	---	---	---
13	---	---	---	---	---	---
14	---	---	---	---	---	---
15	---	---	---	---	---	---

FIGURE 1 – UNIT DIMENSIONS

Units	Width A	Depth B	Height C	Supply		Return		H	I	J
				Duct D	Flange E	Width F	Height G			
ALL	27"	26"	48"	13 7/8"	13 7/8"	22 1/2"	22 1/4"	6"	4 1/4"	1 1/2"

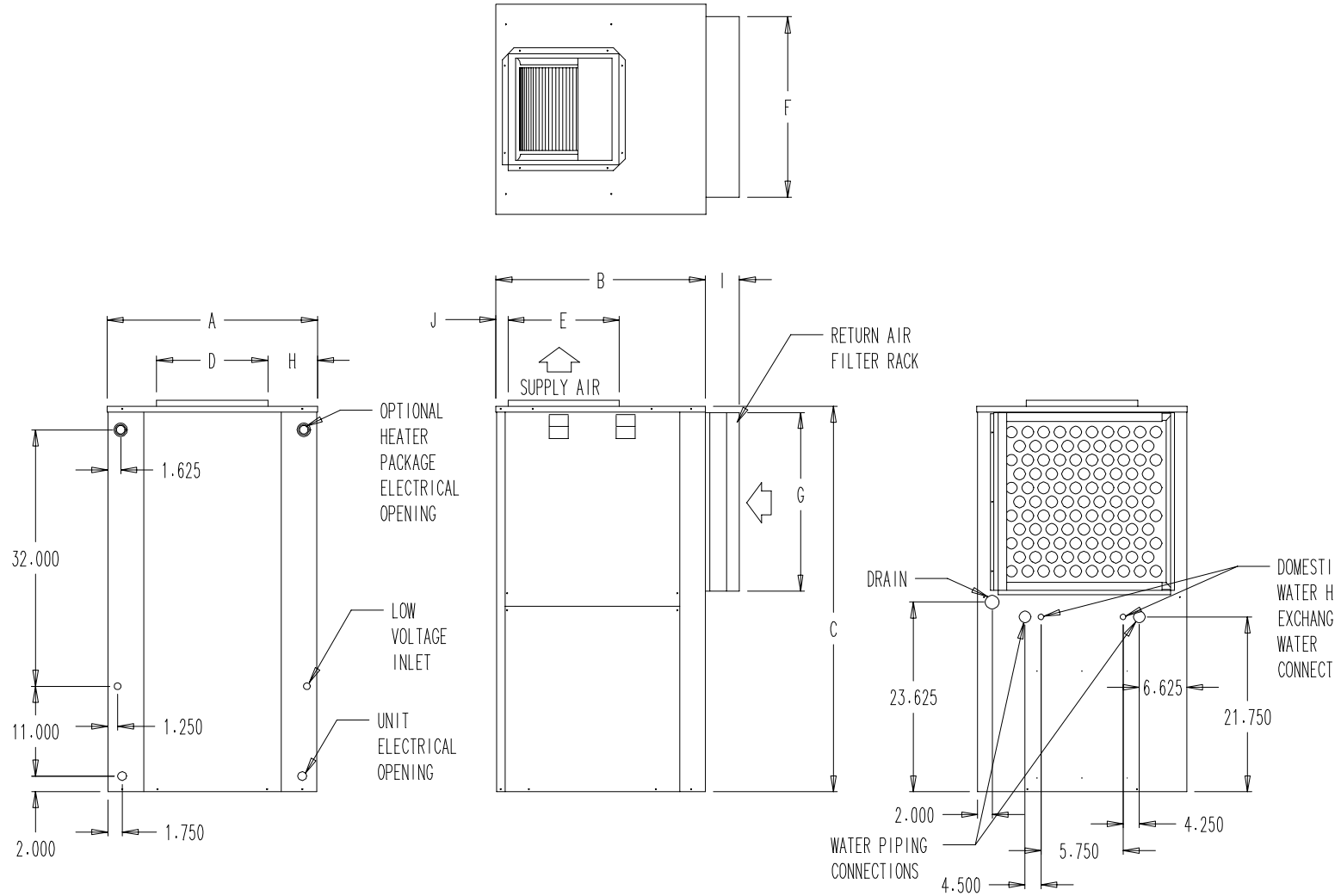

HEATER PACKAGE NOMENCLATURE

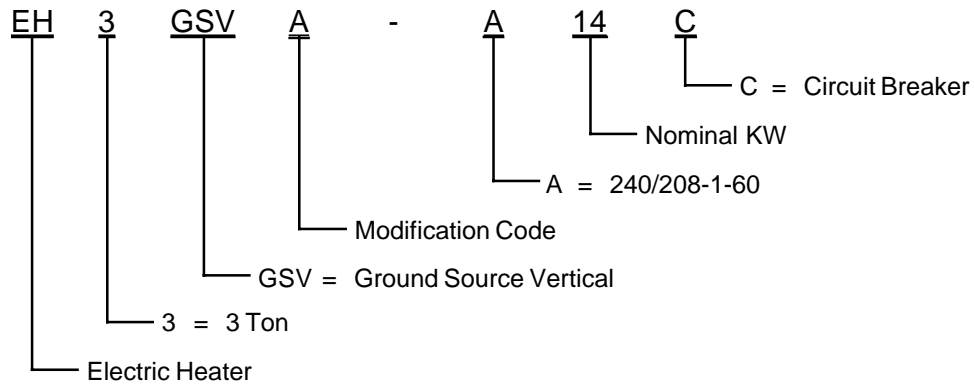

**TABLE 4
ELECTRICAL SPECIFICATIONS
OPTIONAL FIELD-INSTALLED HEATER PACKAGES**

Heater Package Model No.	Heater Package Volts/Phase 60HZ	Heater Amps, KW and Capacity @ 240 Volts			Heater Amps, KW and Capacity @ 208 Volts			Minimum Circuit Ampacity	Maximum Circuit Breaker		Field Wire Size
		AMPS	KW	BTU	AMPS	KW	BTU		HACR	Non-HACR	
EH3GSVA-A05C	240/208-1	18.8	4.5	15,345	16.3	3.38	11,525	23.5	25		10
EH3GSVA-A09C	240/208-1	37.5	9.0	30,690	32.5	6.75	23,018	46.9	50		6
EH3GSVA-A14C	240/208-1	56.3	13.5	46,035	48.7	10.13	34,543	70.4		80	3

APPLICATION AND LOCATION

GENERAL

Units are shipped completely assembled and internally wired, requiring only duct connections, thermostat wiring, 230/208 volt AC power wiring, and water piping. The equipment covered in this manual is to be installed by trained, experienced service and installation technicians. Any heat pump is more critical of proper refrigerant charge and an adequate duct system than a cooling only air conditioning unit.

These instructions and any instructions packaged with any separate equipment required to make up the entire heat pump system should be carefully read before beginning the installation. Note particularly any tags and/or labels attached to the equipment.

While these instructions are intended as a general recommended guide, they do not in any way supersede any national and/or local codes. Authorities having jurisdiction should be consulted before the installation is made.

SHIPPING DAMAGE

Upon receipt of the equipment, the carton should be checked for external signs of shipping damage. If damage is found, the receiving party must contact the last carrier immediately, preferably in writing, requesting inspection by the carrier's agent.

APPLICATION

Capacity of the unit for a proposed installation should be based on heat loss calculations made in accordance with methods of the Air Conditioning Contractors of America, formerly National Warm Air Heating and Air Conditioning Association. The air duct system should be sized and installed in accordance with Standards of the National Fire Protection Association for the Installation of Air Conditioning and Venting systems of Other than Residence Type NFPA No. 90A, and residence Type Warm Air Heating and Air Conditioning Systems, NFPA No. 90B.

LOCATION

The unit may be installed in a basement, closet, or utility room provided adequate service access is insured. The unit is shipped from the factory as a right hand return and requires access clearance of two feet minimum to the access panels on this side of the unit. If unit is to be field

converted to left hand return the opposite side will require access clearance of two feet minimum.

Unit may be field converted to left hand return by removing four (4) screws that secure the control panel cover, removing two (2) screws that hold the control panel in place, sliding the control panel through the compressor compartment and re-securing the control panel on the opposite side of the water coil. (See Figure 2.) The two (2) access doors from the right hand return can be transferred to the left-hand return side and the one (1) left hand panel can be transferred to the right hand side.

Unit casing suitable for 0 inch clearance with 1 inch duct clearance for at least the first 4 feet of duct. These units are not approved for outdoor installation and therefore must be installed inside the structure being conditioned.

Do not locate in areas subject to freezing in the winter or subject to sweating in the summer.

Before setting the unit, consider ease of piping, drain and electrical connections for the unit. Also, for units which will be used with a field installed heat recovery unit, consider the proximity of the unit to the water heater or storage tank. Place the unit on a solid base, preferably concrete, to minimize undesirable noise and vibration. ***DO NOT*** elevate the base pan on rubber or cork vibration eliminator pads as this will permit the unit base to act like a drum, transmitting objectionable noise.

DUCTWORK

If the unit is to be installed in a closet or utility room which does not have a floor drain, a secondary drain pan under the entire unit is highly recommended.

DO NOT install the unit in such a way that a direct path exists between any return grille and the unit. Rather, insure that the air entering the return grille will make at least one turn before entering the unit or coil. This will reduce possible objectionable compressor and air noise from entering the occupied space.

Design the ductwork according to methods given by the Air Conditioning Contractors of America. When duct runs through unconditioned spaces, it should be insulated with vapor barrier. It is recommended that flexible connections be used to connect the ductwork to the unit in order to keep the noise transmission to a minimum.

FIGURE 2
FIELD-CONVERSION TO LEFT HAND RETURN

REMOVE SINGLE AND
 DOUBLE DOORS

- ① REMOVE 4 SCREWS SECURING COVER
- ② REMOVE 2 SCREWS HOLDING CONTROL BOX TO CORNER PANEL
- ③ PASS CONTROL PANEL THROUGH COMPRESSOR SECTION
- ④ RE-SECURE CONTROL PANEL ON OPPOSITE SIDE IN SAME MANNER AS ORIGINALLY ATTACHED

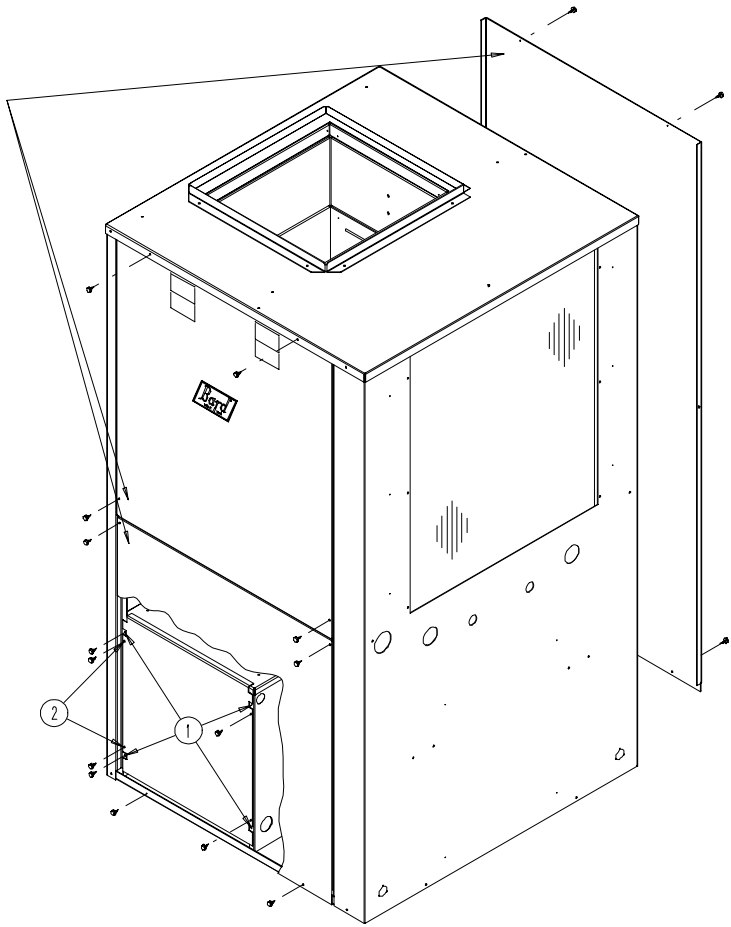

REPOSITION DOORS SO DOUBLE
 DOORS ARE ON CONTROL PANEL
 SIDE, AND SINGLE DOOR ON
 OPPOSITE SIDE

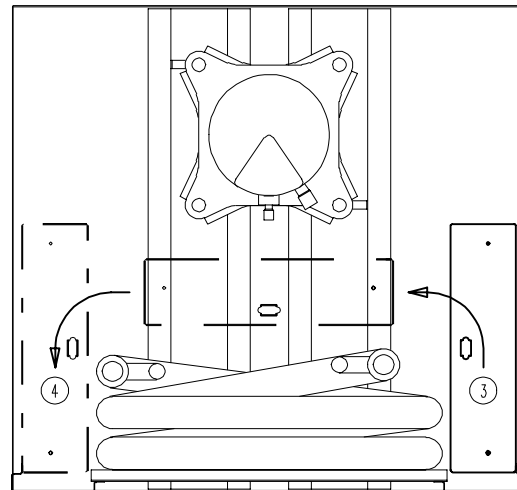

TOP VIEW

FILTER

This unit must not be operated without a filter. It comes equipped with a disposable filter which should be checked often and replaced if dirty. Insufficient air flow due to undersized duct systems or dirty filters can result in nuisance tripping of the high or low pressure control. Refer to Table 2 for correct air flow and static pressure requirements. (See Figure 3.)

CONDENSATE DRAIN

Determine where the drain line will run. This drain line contains cold water and must be insulated to avoid droplets of water from condensing on the pipe and dripping on finished floors or the ceiling under the unit.

FIGURE 3

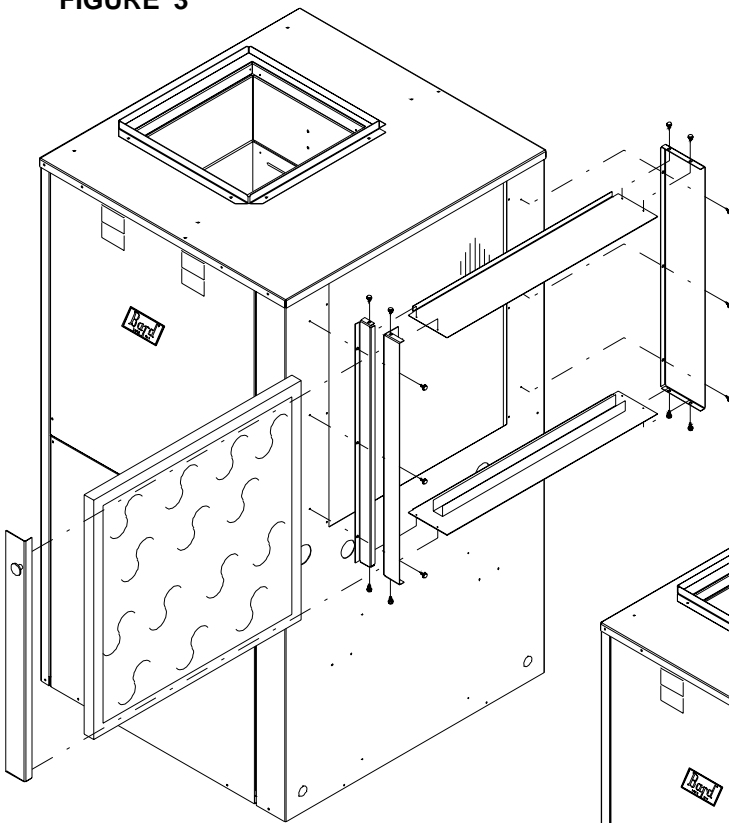

MIS-1212

A trap *MUST BE* installed in the drain line and the trap filled with water prior to start up. The use of plugged tees in place of elbows to facilitate cleaning is highly recommended.

Drain lines must be installed according to local plumbing codes. It is not recommended that any condensate drain line be connected to a sewer main. The drain line enters the unit through the FPT coupling on the coil side of the unit.

PIPING ACCESS TO UNIT

Water piping to and from the unit enters the unit casing from the coil side of the unit under the return air filter rack. Piping connections are made directly to the unit and are 3/4" FPT. (See Figure 4.)

FIGURE 4

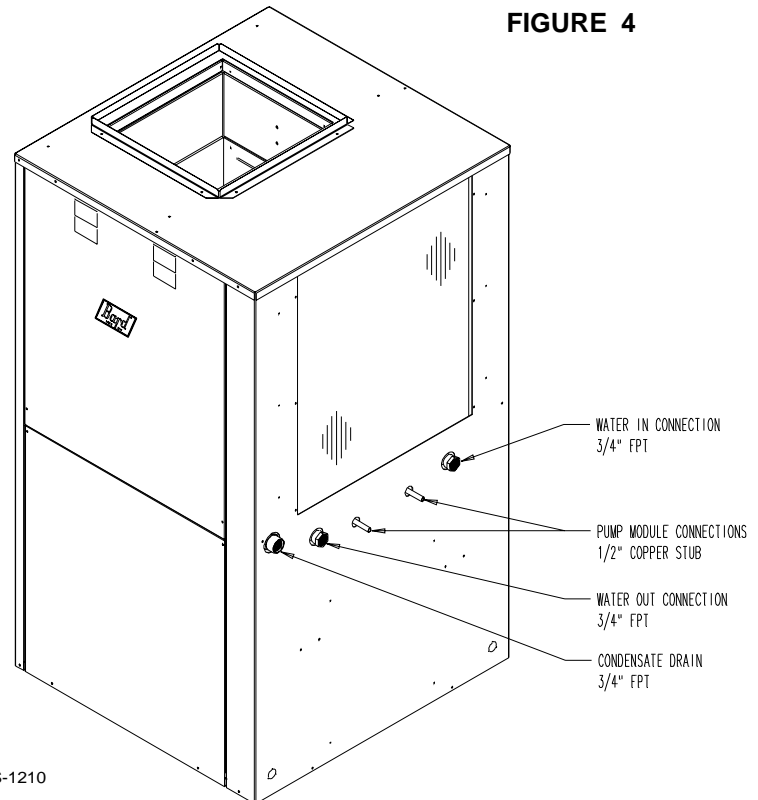

MIS-1210

WIRING INSTRUCTIONS

GENERAL

All wiring must be installed in accordance with the National Electrical Code and local codes. In Canada, all wiring must be installed in accordance with the Canadian Electrical Code and in accordance with the regulations of the authorities having jurisdiction. Power supply voltage must conform to the voltage shown on the unit serial plate. A wiring diagram of the unit is attached to the inside of the electrical cover. The power supply shall be sized and fused according to the specifications supplied. A ground lug is supplied in the control compartment for equipment ground.

The unit rating plate lists a Maximum Time Delay Fuse” or “HACR” type circuit breaker that is to be used with the equipment. The correct size must be used for proper circuit protection and also to assure that there will be no nuisance tripping due to the momentary high starting current of the compressor motor.

CONTROL CIRCUIT WIRING

The minimum control circuit wiring gauge needed to insure proper operation of all controls in the unit will depend on two factors.

1. The rated VA of the control circuit transformer.
2. The maximum total distance of the control circuit wiring.

Table 5 should be used to determine proper gauge of control circuit wiring required.

**TABLE 5
CONTROL CIRCUIT WIRING**

Rated VA of Control Circuit Transformer	Transformer Secondary FLA @ 24V	Maximum Total Distance of Control Circuit Wiring in Feet
50	2.1	20 gauge - 45 18 gauge - 60 16 gauge - 100 14 gauge - 160 12 gauge - 250

Example: 1. Control Circuit transformer rated at 50 VA
2. Maximum total distance of control circuit wiring 85 feet.

From Table 5, minimum of 16 gauge wire should be used in the control circuit wiring.

WALL THERMOSTATS

The following all thermostats and subbases should be used as indicated, depending on the application.

**TABLE 6
WALL THERMOSTAT AND SUBBASE COMBINATIONS**

Part No.	Model No.	Description	Control Diagram
8403-017	T874R1129	Thermostat 1 stage cool, 2 stage heat	4091-500
8404-009	Q674L1181	Subbase 1st stage fixed, 2nd stage heat anticipators System switch: Em. Heat - Heat - Off - Cool Fan switch: On - Off	
8403-027	1F923-71	Thermostat 2 stage cool, 3 stage heat Electronic manual or automatic changeover 2 set-up / set - back periods 5 or 7 day programming	4091-501
8403-035	1F94-80	Thermostat 2 stage cool, 2 stage heat Electronic manual or automatic changeover 1 set-up / set - back period 7 day programming	4091-502
8403-042	T8511G	Thermostat 1 stage cool, 2 stage heat Electronic manual or automatic changeover	4091-503
8403-045	T841A1761	Thermostat 1 stage cool, 2 stage heat 1 stage fixed, 2nd stage adjustable Heat anticipators System Switch: Em. Heat - Heat - Off - Cool Fan Switch: On - Off	4091-504

THERMOSTAT INDICATOR LAMPS

STANDARD INDICATOR LAMPS

The lamp marked “EM” or “EMER.” comes on and stays on whenever the system switch is placed in the emergency heat position.

The lamp marked “CHECK” or “MALF.” will *flash* if the *high pressure switch* opens and locks out compressor operation. The “CHECK” or “MALF.” lamp will *come on and stay on* if the *low pressure switch* closes and locks out compressor operation. To reset either the high or low pressure switch, place the thermostat in the off position then back to the on position.

OPTIONAL INDICATOR LAMPS

The lamp marked “PUMP” comes on and stays on anytime the compressor is on.

The lamp marked “AUX” comes on and stays on anytime electric heaters are on.

EMERGENCY HEAT POSITION

The operator of the equipment must manually place the system switch in this position. This is done when there is a known problem with the unit, or when the “CHECK” or “MALF.” lamp comes on indicating a problem.

BLOWER CONTROL SETUP

Due to the unique functions that the ECM blower motor is able to perform each installation requires that the jumpers on the blower control board be checked and possibly moved based on the final installation. (See Figure 5.) Check

Table 7 to verify the ADJUST, HEAT, COOL, and DELAY taps are set in the proper location for the installation.

HUMIDITY CONTROL

With the use of optional humidistat 8403-038 cut jumper on blower control board marked “cut to enable” (refer to ⑤ on Figure 5) to allow the humidistat to reduce the blower airflow in the dehumidify mode. By reducing the airflow the air coil runs colder and thus extracts more moisture. This can increase latent capacity from 5 to 13% based on the R/H conditions of the structure being conditioned. Refer to control circuit diagram for wiring of humidistat.

CFM LIGHT

The light marked CFM on the blower control board (refer to ⑥ on Figure 5) alternates between blinking 1 second per approximately 100 CFM of air delivered by the blower, and a solid light with 1 second off period between modes.

TABLE 7

1. Adjust	<ul style="list-style-type: none"> Norm - Unit shipped with jumper in this position (+) - Jumper in this position increases airflow 15% (-) - Jumper in this position decreases airflow 15% Test - Not used in this application.
2. Heat	<ul style="list-style-type: none"> A. - 0 kW unit shipped with jumper in this position B. - 4.5 kW heater package installed jumper in this position C. - 9 kW heater package installed jumper in this position D. - 14kW heater package installed jumper in this position
3. Cool	<ul style="list-style-type: none"> A. - Unit shipped with jumper in this position B. - Jumper in this position when any heater package installed C. - Not used in this application D. - Not used in this application
4. Delay	<ul style="list-style-type: none"> A. - No delay unit shipped with jumper in this position B. - 1 min. blower delay on shut down with 56% airflow C. - 2 1/2 min. short run on start with 75% airflow plus tap B delay D. - 1 min. pre-run on start with 38% airflow plus tap B and C delay

FIGURE 5

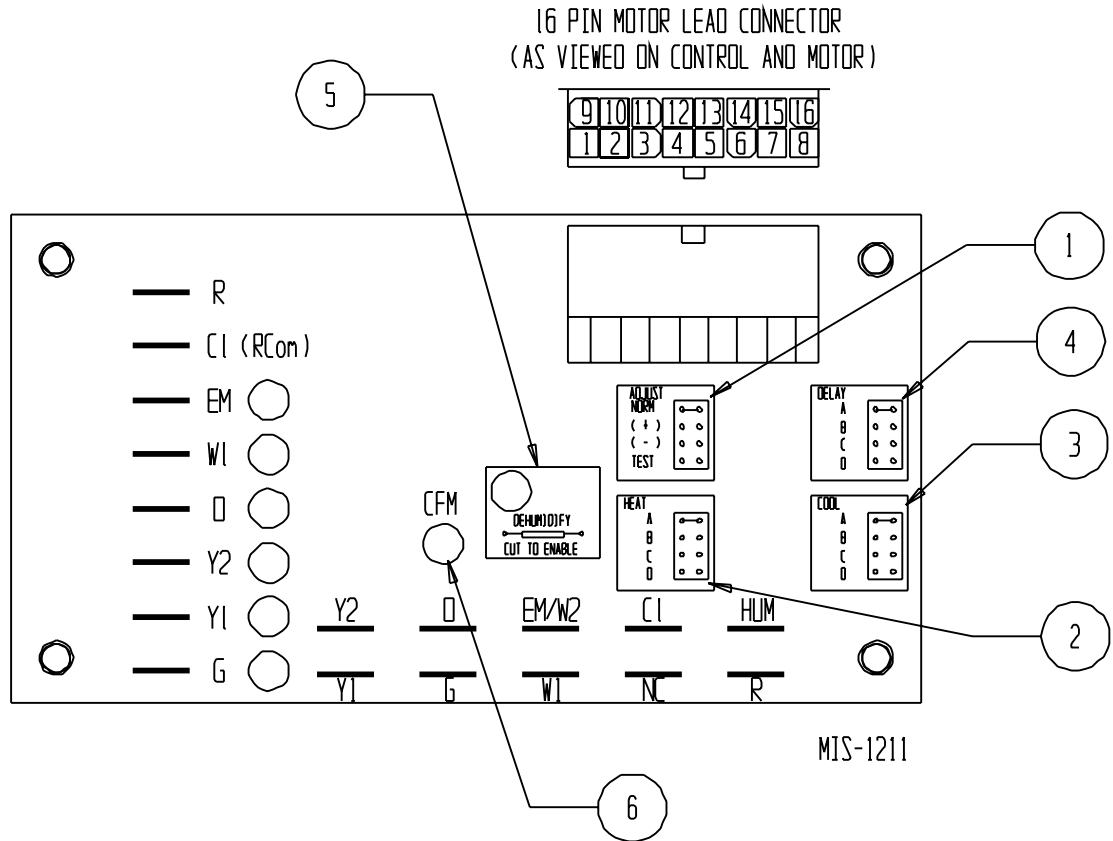

MOTOR LEAD CONNECTOR INFORMATION

PIN	DESCRIPTION	WIRE COLOR
1	C1	BLACK
2	W1	BLUE
3	C2	BLACK
4	DELAY	WHITE
5	COOL	PURPLE
6	Y1	YELLOW
7	ADJUST	TAN
8	OUT-	BLACK
9	O	BROWN
10	BK/PWM	GREEN
11	HEAT	PURPLE
12	R	RED
13	EM/W2	PINK
14	Y2	YELLOW
15	G	ORANGE
16	OUT+	BLACK

16 PIN MOTOR LEAD CONNECTOR
(AS VIEWED FROM PIN END OF CONNECTOR LEADS)

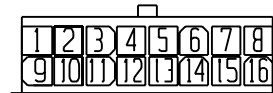

MIS-1211

⚠ THERMOSTAT/SUBBASE
T874R1129/G674L1181

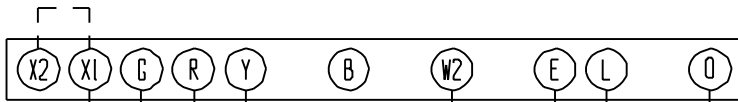

UNIT 24V
TERMINAL BLOCK

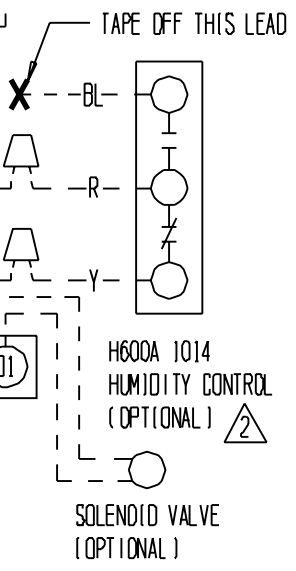
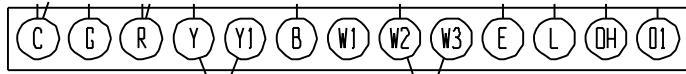

- ⚠ SET ADJUST HEAT ANTICIPATOR AT .45A
- ⚠ REFER TO SECTION "HUMIDITY CONTROL" FOR SET UP

	FACTORY WIRING	FIELD WIRING
LOW VOLTAGE	—	- - - -
HIGH VOLTAGE	—	- - - -

4091-500 A

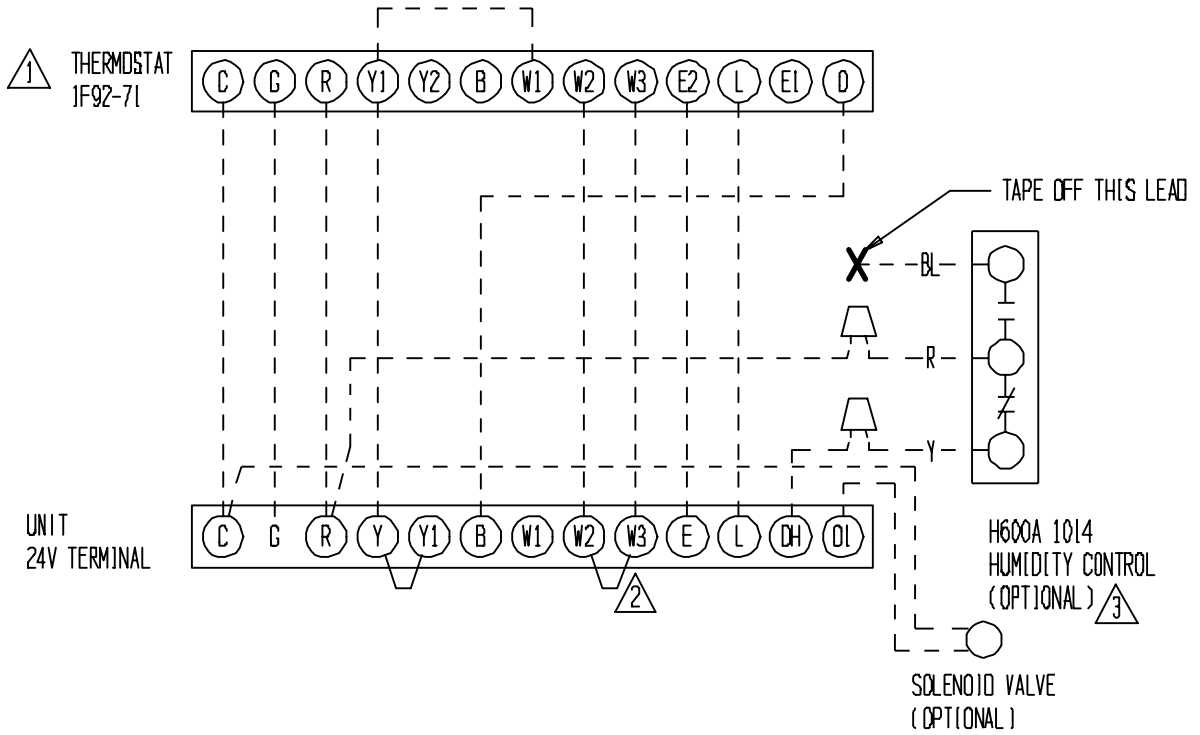

1 OPTION SWITCH SETTING

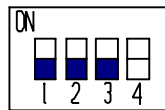

SWITCH #1 "OFF"
 SWITCH #2 "OFF"
 SWITCH #3 "OFF"
 SWITCH #4 SEE THERMOSTAT
 INSTALLATION INSTRUCTIONS

2 REMOVE JUMPER "W2" "W3"

3 REFER TO SECTION "HUMIDITY CONTROL" FOR SET UP

	FACTORY WIRING	FIELD WIRING
LOW VOLTAGE	_____	-----
HIGH VOLTAGE	—————	-----

4091-501 A

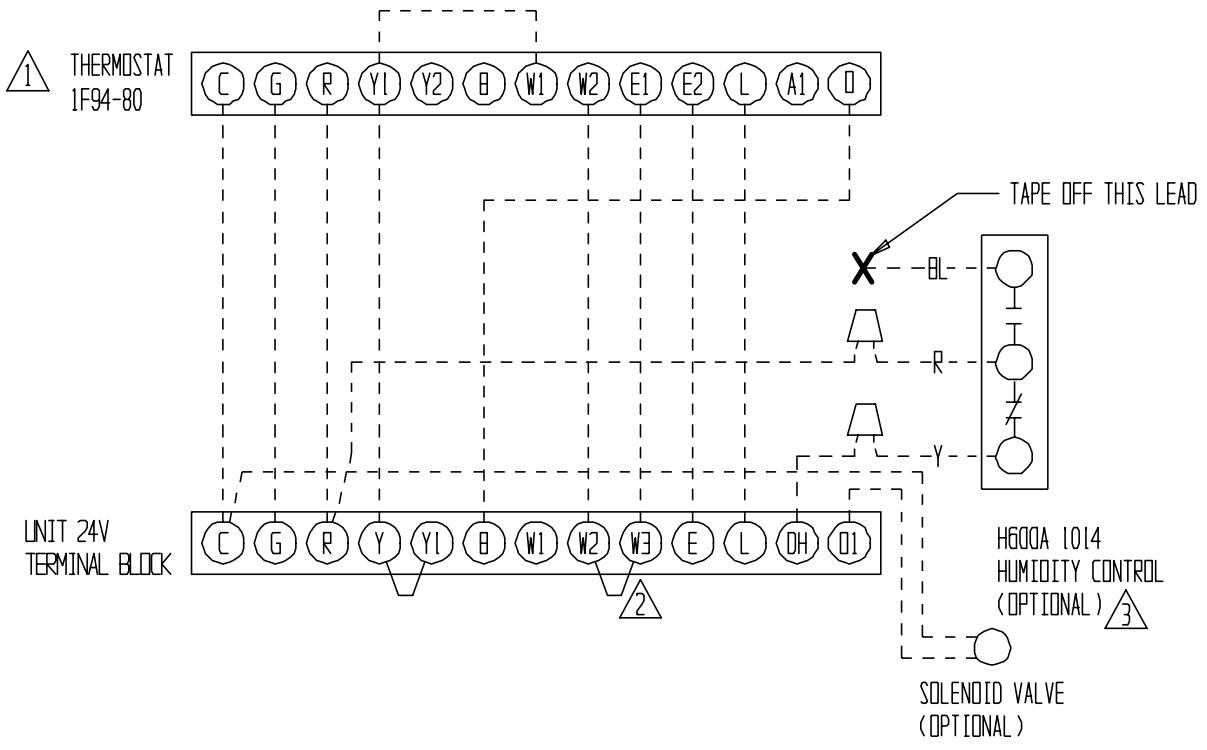

1 OPTION SWITCH SETTING

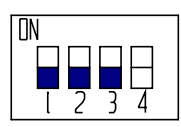

- SWITCH #1 "OFF"
- SWITCH #2 "OFF"
- SWITCH #3 "OFF"
- SWITCH #4 SEE THERMOSTAT INSTALLATION INSTRUCTIONS

2 REMOVE JUMPER "W2" "W3"

3 REFER TO SECTION "HUMIDITY CONTROL" FOR SET UP

	FACTORY WIRING	FIELD WIRING
LOW VOLTAGE	_____	-----
HIGH VOLTAGE	—————	-----

4091-502 A



THERMOSTAT T8511G

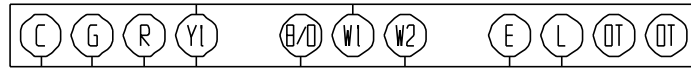

UNIT 24V
TERMINAL BLOCK

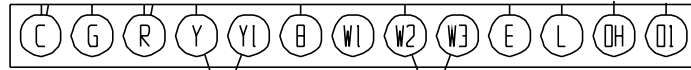

TAPE OFF THIS LEAD

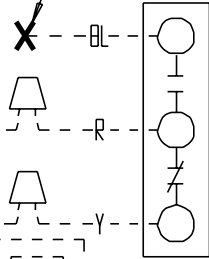

H600A 1014
HUMIDITY CONTROL
(OPTIONAL)

SOLENOID VALVE
(OPTIONAL)



SEE THERMOSTAT INSTALLATION INSTRUCTIONS FOR SET UP



REFER TO SECTION "HUMIDITY CONTROL" FOR SET UP

	FACTORY WIRING	FIELD WIRING
LOW VOLTAGE	_____	-----
HIGH VOLTAGE	—————	-----

4091-503 A

⚠ THERMOSTAT T841A1761

UNIT 24V
TERMINAL BLOCK

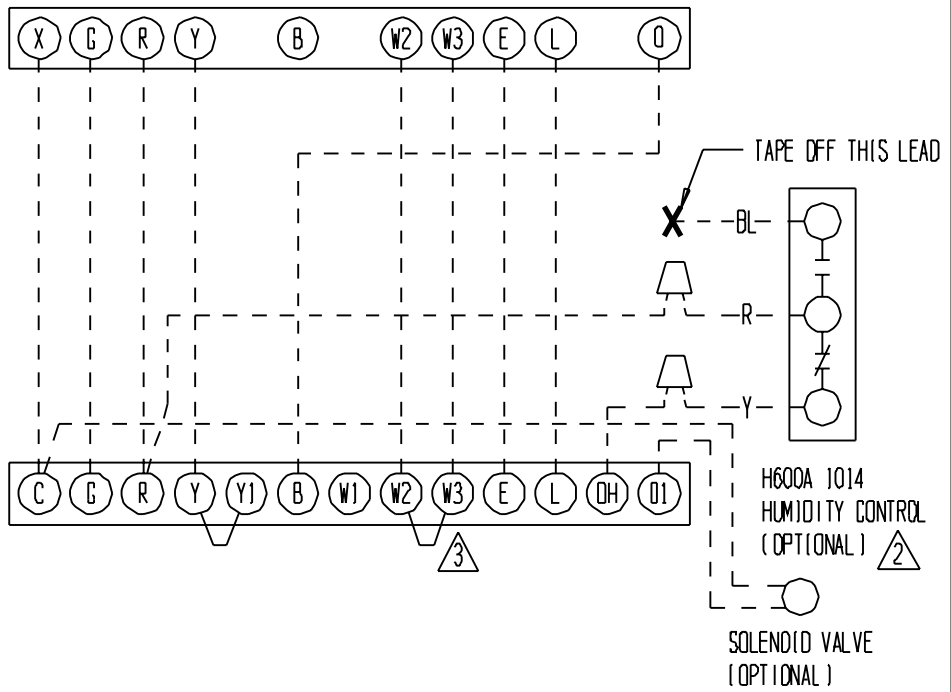

- ⚠ SET ADJUST HEAT ANTICIPATOR AT .45A
- ⚠ REFER TO SECTION "HUMIDITY CONTROL" FOR SET UP
- ⚠ REMOVE JUMPER "W2" & "W3"

	FACTORY WIRING	FIELD WIRING
LOW VOLTAGE	_____	-----
HIGH VOLTAGE	—————	-----

4091-504

CLOSED LOOP (Earth Coupled Ground Loop Applications)

NOTE:

Unit shipped from factory with 27 PSIG low pressure switch wired into control circuit and must be rewired to 15 PSIG low pressure switch for closed loop applications. This unit is designed to work on earth coupled ground loop systems, however, these systems operate at entering water (without antifreeze) temperature with pressures well below the pressures normally experienced in water well systems.

THE CIRCULATION SYSTEM DESIGN

Equipment room piping design is based on years of experience with earth coupled heat pump systems. The design eliminates most causes of system failure.

Surprisingly, the heat pump itself is rarely the cause. Most problems occur because designers and installers forget that a closed loop earth coupled heat pump system is NOT like a household plumbing system.

Most household water systems have more than enough water pressure either from the well pump or the municipal water system to overcome the pressure of head loss in 1/2 inch or 3/4 inch household plumbing. A closed loop earth coupled heat pump system, however, is separated from the pressure of the household supply and relies on a small, low wattage pump to circulate the water and antifreeze solution through the earth coupling, heat pump and equipment room components.

The small circulator keeps the operating costs of the system to a minimum. However, the performance of the circulator MUST be closely matched with the pressure of head loss of the entire system in order to provide the required flow through the heat pump. Insufficient flow through the heat exchanger is one of the most common causes of system failure. Proper system piping design and circulator selection will eliminate this problem.

Bard supplies a worksheet to simplify head loss calculations and circulator selection. Refer to "Circulating Pump Worksheet" section in manual 2100-099.

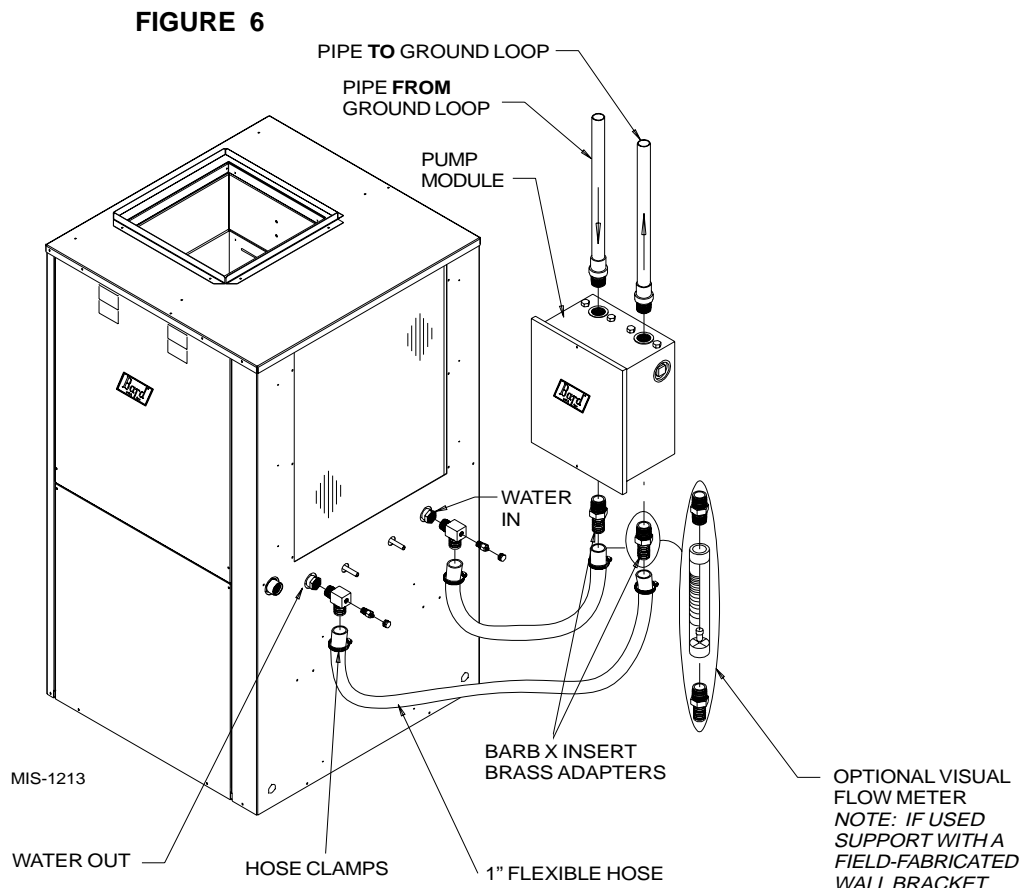

START UP PROCEDURE FOR CLOSED LOOP SYSTEM

1. Be sure main power to the unit is OFF at disconnect.
 2. Set thermostat system switch to OFF, fan switch to AUTO.
 3. Move main power disconnect to ON. Except as required for safety while servicing, *DO NOT OPEN THE UNIT DISCONNECT SWITCH.*
 4. Check system air flow for obstructions.
 - A. Move thermostat fan switch to ON. Blower runs.
 - B. Be sure all registers and grilles are open.
 - C. Move thermostat fan switch to AUTO. Blowing should stop.
 5. Flush, fill and pressurize the closed loop system as outlined in manual 2100-099.
 6. Fully open the manual inlet and outlet valves. Start the loop pump module circulator(s) and check for proper operation. If circulator(s) are not operating, turn off power and diagnose the problem.
 7. Check fluid flow using a direct reading flow meter or a single water pressure gauge, measure the pressure drop at the pressure/temperature plugs across the water coil. Compare the measurement with flow versus pressure drop table to determine the actual flow rate. If the flow rate is too low, recheck the selection of the loop pump module model for sufficient capacity. If the module selection is correct, there is probably trapped air or a restriction in the piping circuit.
 8. Start the unit in cooling mode. By moving the thermostat switch to cool, fan should be set for AUTO.
 9. Check the system refrigerant pressures against the cooling refrigerant pressure table in the installation manual for rated water flow and entering water temperatures. If the refrigerant pressures do not match, check for air flow problem then refrigeration system problem.
 10. Switch the unit to the heating mode. By moving the thermostat switch to heat, fan should be set for AUTO.
 11. Check the refrigerant system pressures against the heating refrigerant pressure table in installation manual. Once again, if they do not match, check for air flow problems and then refrigeration system problems.
- NOTE:* If a charge problem is determined (high or low):
- A. Check for possible refrigerant leaks.
 - B. Recover all remaining refrigerant from unit and repair leak.
 - C. Evacuate unit down to 29 inches of vacuum
 - D. Recharge the unit with refrigerant by weight. This is the only way to insure a proper charge.

FIGURE 7

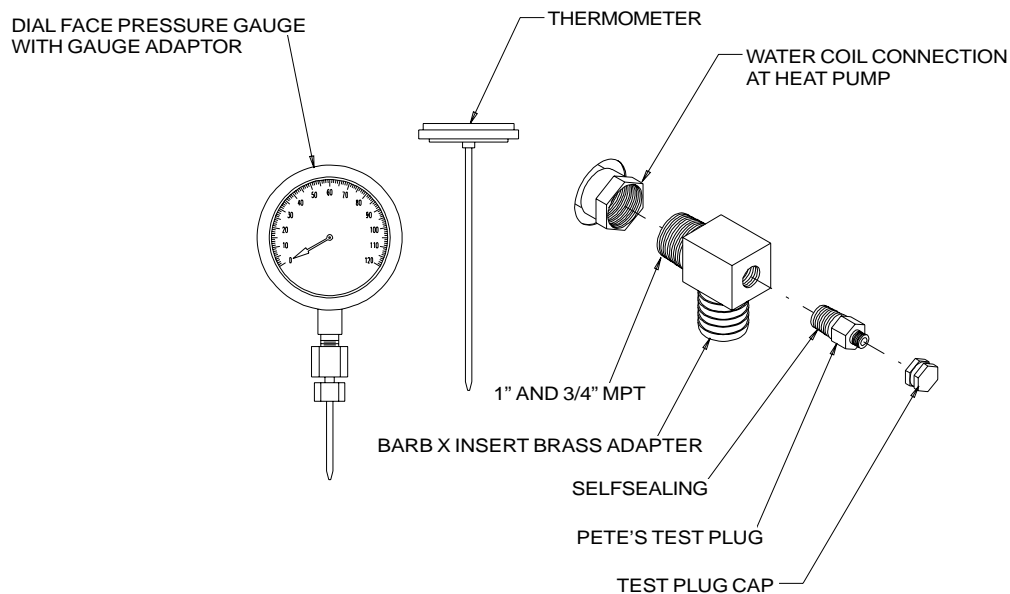

FIGURE 8
PERFORMANCE MODEL GPM-1 LOOP PUMP MODULE

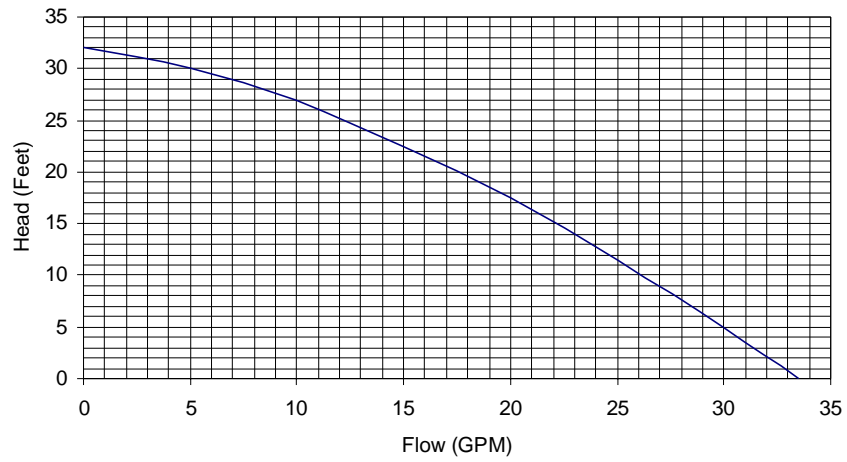
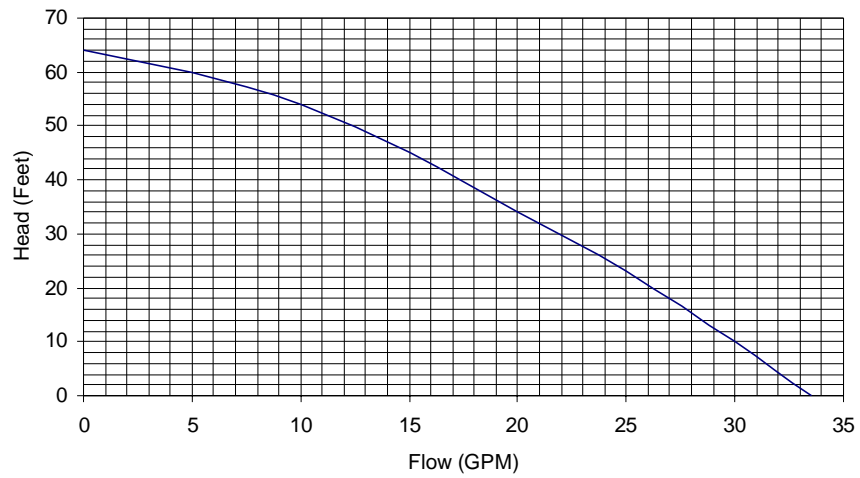

FIGURE 9
PERFORMANCE MODEL GPM-2 LOOP PUMP MODULE



OPEN LOOP (Well System Applications)

NOTE:

Unit shipped from factory with 27 PSIG low pressure switch wired into control circuit for open loop applications.

WATER CONNECTIONS

It is very important that an adequate supply of clean, noncorrosive water at the proper pressure be provided before the installation is made. Insufficient water, in the heating mode for example, will cause the low pressure switch to trip, shutting down the heat pump. In assessing the capacity of the water system, it is advisable that the complete water system be evaluated to prevent possible lack of water or water pressure at various household fixtures whenever the heat pump turns on. All plumbing to and from the unit is to be installed in accordance with local plumbing codes. The use of plastic pipe, where permissible, is recommended to prevent electrolytic corrosion of the water pipe. Because of the relatively cold temperatures encountered with well water, it is strongly recommended that the water lines connecting the unit be insulated to prevent water droplets from condensing on the pipe surface.

Refer to piping, Figure 10. Slow closing *Solenoid Valve (6)* with a 24 V coil provides on/off control of the water flow to the unit. Refer to the wiring diagram for correct hookup of the valve solenoid coil.

Constant Flow Valve (7) provides correct flow of water to the unit regardless of variations in water pressure. Observe the water flow direction indicated by the arrow on the side of the valve body. Following is a table showing which valve is to be installed with which heat pump.

**TABLE 8
CONSTANT FLOW VALVES**

Part No.	Min. Available Pressure PSIG	Flow Rate GPM
8603-007	15 (1)	6
8603-008	15 (1)	8
8603-010	15 (1)	4
8603-011	15 (1)	5
8603-019	15 (1)	3

(1) The pressure drop through the constant flow valve will vary depending on the available pressure ahead of the valve. Unless minimum of 15 psig is available **immediately** ahead of the valve, no water will flow.

Strainer (5) installed upstream of *constant flow valve (7)* to collect foreign material which would clog the flow valve orifice.

The figure shows the use of *shutoff valves (9)* and *(11)*, on the in and out water lines to permit isolation of the unit from the plumbing system should future service work require this. Globe valves should not be used as shutoff valves because of the excessive pressure drop inherent in the valve design. Instead use gate or ball valves as shutoffs so as to minimize pressure drop.

Drain cock (8) and *(10)*, and tees have been included to permit acid cleaning the refrigerant-to-water coil should such cleaning be required. See WATER CORROSION.

Drain cock (12) provides access to the system to check water flow through the constant flow valve to insure adequate water flow through the unit. A water meter is used to check the water flow rate.

WELL PUMP SIZING

Strictly speaking, sizing the well pump is the responsibility of the well drilling contractor. It is important, however, that the HVAC contractor be familiar with the factors that determine what size pump will be required. Rule of thumb estimates will invariably lead to under or oversized well pumps. Undersizing the pump will result in inadequate water to the whole plumbing system but with especially bad results to the heat pump – NO HEAT / NO COOL calls will result. Oversized pumps will short cycle and could cause premature pump motor or switch failures.

The well pump must be capable of supplying enough water and at an adequate pressure to meet competing demands of water fixtures. The well pump must be sized in such a way that three requirements are met:

1. Adequate flow rate in GPM.
2. Adequate pressure at the fixture.
3. Able to meet the above from the depth of the well-feet of lift.

The pressure requirements put on the pump are directly affected by the diameter of pipe being used, as well as, by the water flow rate through the pipe. The worksheet included in manual 2110-078 should guarantee that the well pump has enough capacity. It should also ensure that the piping is not undersized which would create too much pressure due to friction loss. High pressure losses due to undersized pipe will reduce efficiency and require larger pumps and could also create water noise problems.

FIGURE 10
WATER CONNECTION COMPONENTS

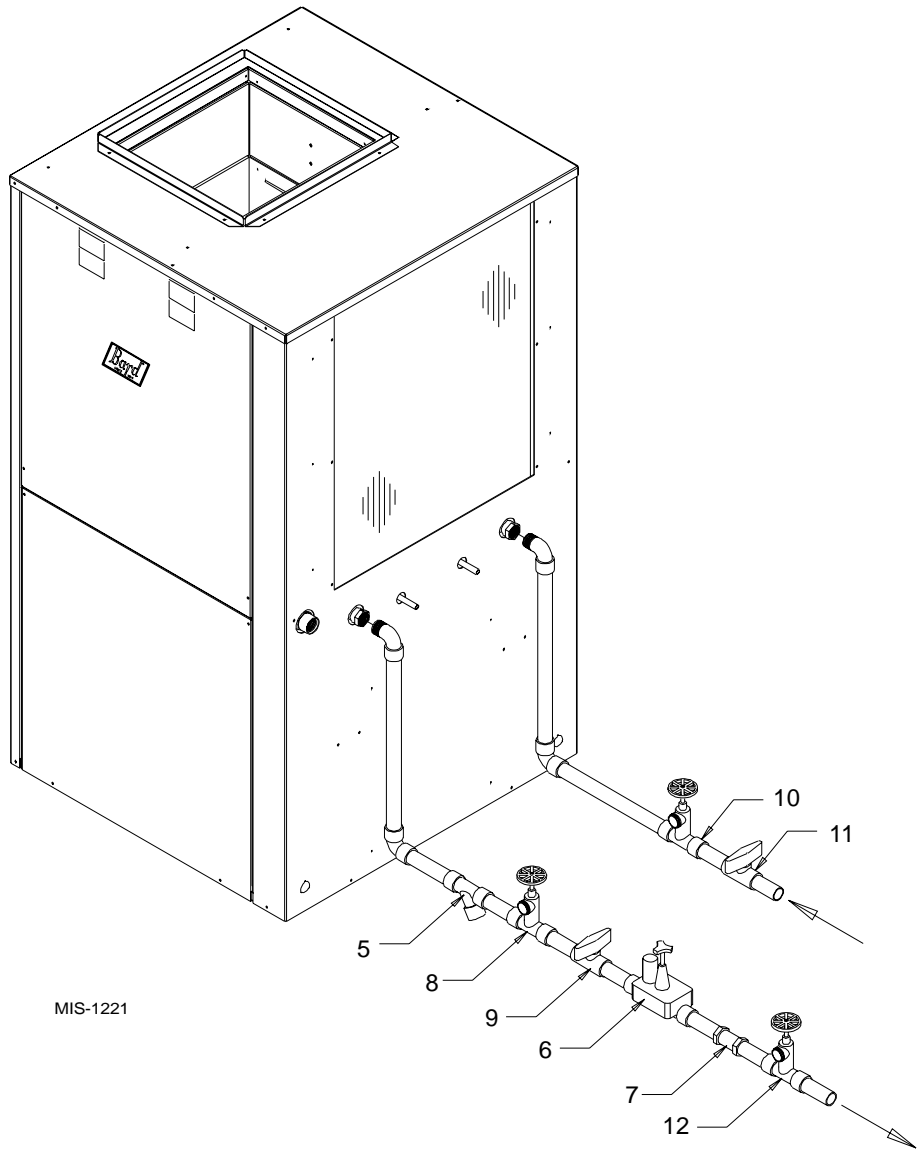

MIS-1221

SYSTEM START UP PROCEDURE FOR OPEN LOOP APPLICATIONS

1. Be sure main power to the unit is OFF at disconnect.
2. Set thermostat system switch to OFF, fan switch to AUTO.
3. Move main power disconnect to ON. Except as required for safety while servicing – *DO NOT OPEN THE UNIT DISCONNECT SWITCH.*
4. Check system air low for obstructions.
 - A. Move thermostat fan switch to ON. Blower runs.
 - B. Be sure all registers and grilles are open.
 - C. Move thermostat fan switch to AUTO. Blower should stop.
5. Fully open the manual inlet and outlet valves.
6. Check water flow.
 - A. Connect a water flow meter to the drain cock between the constant flow valve and the solenoid valve. Run a hose from the flow meter to a drain or sink. Open the drain cock.
 - B. Check the water flow rate through constant flow valve to be sure it is the same as the unit is rated for. (Example: 4 GPM for a GSVS301-A.)
 - C. When water flow is okay, close drain cock and remove the water flow meter. the unit is now ready to start.
7. Start the unit in cooling mode. By moving the thermostat switch to cool, fan should be set for AUTO.
 - A. Check to see the solenoid valve opened.
8. Check the system refrigerant pressures against the cooling refrigerant pressure table in the installation manual for rated water flow and entering water temperatures. If the refrigerant pressures do not match, check for air flow problem that refrigeration system problem.
9. Switch the unit to the heat mode. By moving the thermostat switch to heat, fan should be set for AUTO.
 - A. Check to see the solenoid valve opened again.
10. Check the refrigerant system pressures against the heating refrigerant pressure table in installation manual. Once again, if they do not match, check for air flow problems and then refrigeration system problems.

NOTE: If a charge problem is determined (high or low):

 - A. Check for possible refrigerant loss.
 - B. Discharge all remaining refrigerant from unit.
 - C. Evacuate unit down to 29 inches of vacuum.
 - D. Recharge the unit with refrigerant by weight.
This is the only way to insure proper charge.

WATER CORROSION

Two concerns will immediately come to light when considering a water source heat pump, whether for ground water or for a closed loop application: Will there be enough water? And, how will the water quality affect the system?

Water quantity is an important consideration and one which is easily determined. The well driller must perform a pump down test on the well according to methods described by the Nation Well Water Association. This test, if performed correctly, will provide information on the rate of low and on the capacity of the well. It is important to consider the overall capacity of the well when thinking about a water source heat pump because the heat pump may be required to run for extended periods of time.

The second concern, about water quality, is equally important. Generally speaking, if the water is not offensive for drinking purposes, it should pose no problem for the heat pump. The well driller or local water softening company can perform tests which will determine the chemical properties of the well water.

Water quality problems will show up in the heat pump in one of more of the following ways:

1. Decrease in water flow through the unit.
2. Decreased heat transfer of the water coil (entering to leaving water temperature difference is less).

There are four main water quality problems associated with ground water. These are:

1. **Biological Growth.** This is the growth of microscopic organisms in the water and will show up as a slimy deposit throughout the water system. Shock treatment of the well is usually required and this is best left up to the well driller. The treatment consists of injecting chlorine into the well casing and flushing the system until all growth is removed.
2. **Suspended Particles in the Water.** Filtering will usually remove most suspended particles (fine sand, small gravel) from the water. The problem with suspended particles in the water is that it will erode metal parts, pumps, heat transfer coils, etc. So long as the filter is cleaned and periodically maintained, suspended particles should pose no serious problem. Consult with your well driller.
3. **Corrosion of Metal.** Corrosion of metal parts results from either highly corrosive water (acid water, generally not the case with ground water) or galvanic reaction between dissimilar metals in the presence of water. By using plastic plumbing or dielectric unions galvanic reaction is eliminated. The use of corrosion resistant materials such as the Cupro nickel coil through the water system will reduce corrosion problems significantly.

4. **Scale Formation.** Of all the water problems, the formation of scale by ground water is by far the most common. Usually this scale is due to the formation of calcium carbonate by magnesium carbonate or calcium sulfate may also be present. Carbon dioxide gas (CO₂), the carbonate of calcium and magnesium carbonate, is very soluble in water. It will remain dissolved in the water until some outside factor upsets the balance. This outside influence may be a large change in water temperature or pressure. When this happens, enough carbon dioxide gas combines with dissolved calcium or magnesium in the water and falls out of solution until a new balance is reached. The change in temperature that this heat pump produces is usually not high enough to cause the dissolved gas to fall out of solution. Likewise, if pressure drops are kept to a reasonable level, no precipitation of carbon dioxide should occur.

REMEDIES OF WATER PROBLEMS

Water Treatment. Water treatment can usually be economically justified for close loop systems. However, because of the large amounts of water involved with a ground water heat pump, water treatment is generally too expensive.

Acid Cleaning the Water Coil or Heat Pump

Recovery Unit. If scaling of the coil is strongly suspected, the coil can be cleaned up with a solution of Phosphoric Acid (food grade acid). Follow the manufacturer's directions for mixing, use, etc. Refer to the "Cleaning Water Coil", Figure 12. The acid solution can be introduced into the heat pump coil through the hose bib A. Be sure the isolation valves are closed to prevent contamination of the rest of the system by the coil. The acid should be pumped from a bucket into the hose bib and returned to

the bucket through the other hose bib B. Follow the manufacturer's directions for the product used as to how long the solution is to be circulated, but it is usually circulated for a period of several hours.

LAKE AND POND INSTALLATIONS

Lakes and ponds can provide a low cost source of water for heating and cooling with a ground water heat pump. Direct usage of the water without some filtration is not recommended as algae and turbid water can foul the water to freon heat exchanger. Instead, there have been very good results using a dry well dug next to the water line or edge. Normal procedure in installing a dry well is to backhoe a 15 to 20 foot hole adjacent to the body of water (set backhoe as close to the water's edge as possible). Once excavated, a perforated plastic casing should be installed with gravel backfill placed around the casing. The gravel bed should provide adequate filtration of the water to allow good performance of the ground water heat pump.

The following is a list of recommendations to follow when installing this type of system:

- A. A lake or pond should be at least 1 acre (40,000 square feet) in surface area for each 50,000 BTUs of ground water heat pump capacity or have 2 times the cubic feet size of the dwelling that you are trying to heat (includes basement if heated).
- B. The average water depth should be at least 4 feet and there should be an area where the water depth is at least 12 to 15 feet deep.
- C. If possible, use a submersible pump suspended in the dry well casing. Jet pumps and other types of suction pumps normally consume more electrical energy than similarly sized submersible pumps. Pipe the unit the same as a water well system.

**FIGURE 11
CLEANING WATER COIL**

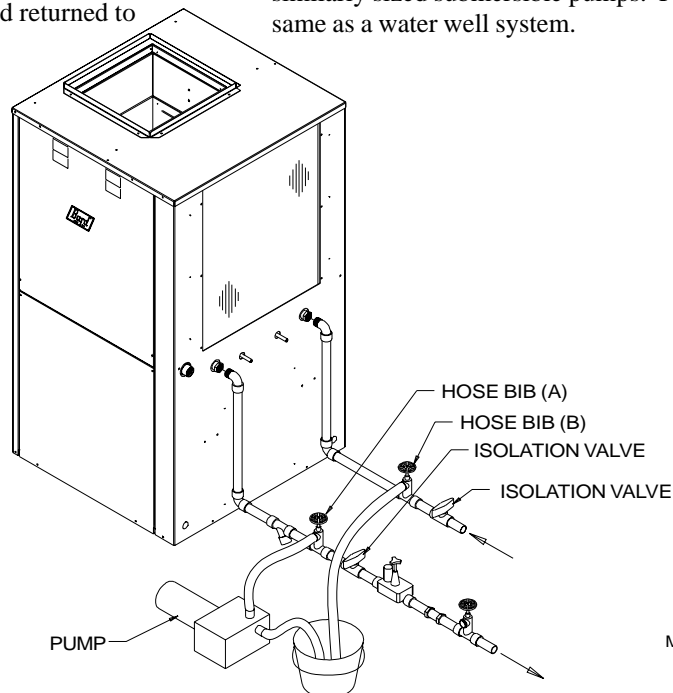

MIS-1222

- D. Size the pump to provide necessary GPM for the ground water heat pump. A 12 GPM or greater water flow rate is required on all modes when used on this type system.
- E. A pressure tank should be installed in dwelling to be heated adjacent to the ground water heat pump. A pressure switch should be installed at the tank for pump control.
- F. All plumbing should be carefully sized to compensate for friction losses, etc., particularly if the pond or lake is over 200 feet from the dwelling to be heated or cooled.
- G. Keep all water lines below low water level and below the frost line.
- H. Most installers use 4 inch filed tile (rigid plastic or corrugated) for water return to the lake or pond.
- I. The drain line discharge should be located at least 100 feet from the dry well location.
- J. The drain line should be installed with a slope of 2 inches per 10 feet of run to provide complete drainage of the line when the ground water heat pump is not operating. This gradient should also help prevent freezing of the discharge where the pipe terminates above the frost line.

- K. Locate the discharge high enough above high water level so the water will not back up and freeze inside the drain pipe.
- L. Where the local conditions prevent the use of a gravity drainage system to a lake or pond, you can instead run standard plastic piping out into the pond below the frost and low water level.

 WARNING
Thin ice may result in the vicinity of the discharge line.

For complete information on water well systems and lake and pond applications, refer to Manual 2100-078 available from your distributor.

**FIGURE 12
LAKE OR POND INSTALLATION**

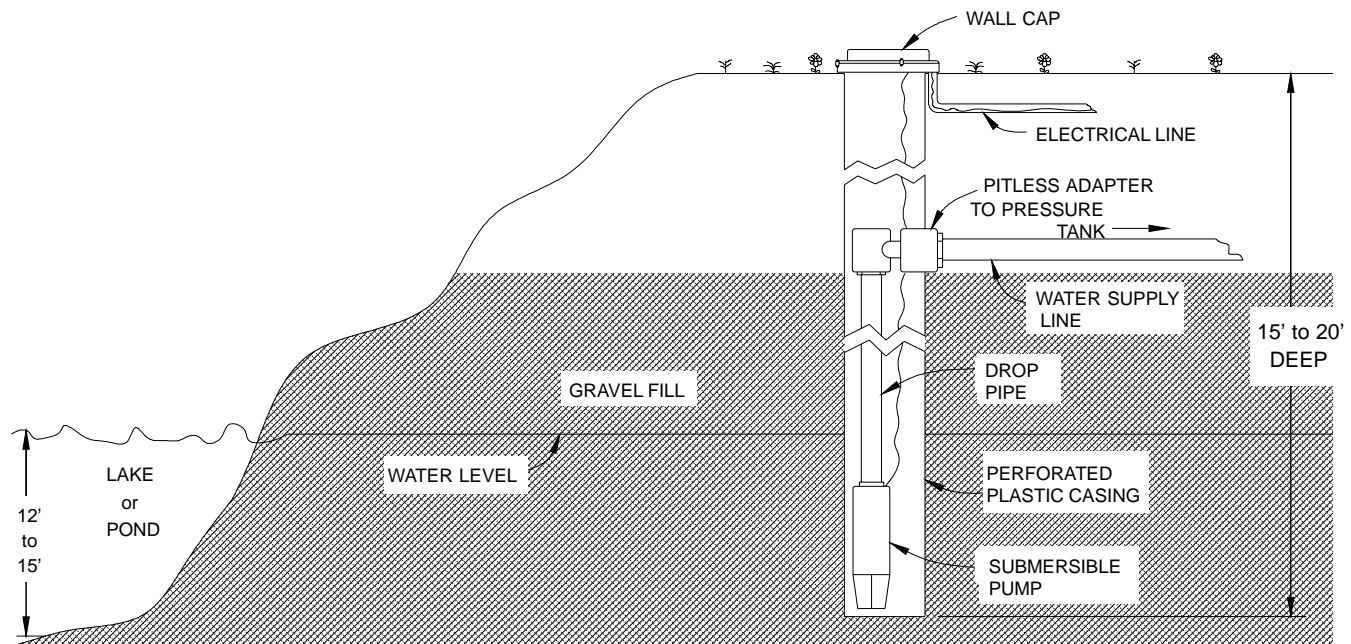

MIS-1607

SEQUENCE OF OPERATION

COOLING

When thermostat system switch is placed in COOL it completes a circuit from “R” to “O”, energizing the reversing valve solenoid. On a call for cooling, the cooling bulb completes a circuit from “R” to “Y”, energizing the compressor contactor starting the compressor. The “R” to “G” circuit for blower operation is automatically completed on any call for cooling operation, or can be energized by manual fan switch on subbase for constant air circulation.

HEATING WITHOUT ELECTRIC HEAT

When thermostat system switch is placed in HEAT it opens the circuit from “R” to “O”, de-energizing the reversing valve solenoid. On a call for heating, it completes a circuit from “R” to “Y”, energizing the compressor contactor starting the compressor. The “R” to “G” circuit for blower operation is automatically completed on any call for heating operation, or can be energized by manual fan switch on subbase for constant air circulation.

HEATING WITH ELECTRIC HEAT

The first stage of heating is the same as heating without electric heat. When the second stage thermostat bulb makes, a circuit is completed between “R” to “W1”, energizing the heater package time delay relay(s). The electric heater elements will remain energized until the second stage bulb is satisfied at which time the circuit between “R” to “W1” will open de-energizing the heat package time delay relay(s).

EMERGENCY HEAT

When thermostat system switch is placed in EMER, the compressor circuit “R” to “Y” is locked out. Control of the electric heaters is from “R” to “W1” through the thermostat second stage heating bulb. Blower operation is controlled by an interlock circuit with the electric heater time delay relay and the blower control. The electric heater elements will remain energized until the second stage bulb is satisfied at which time the circuit between “R” and “W1” will open de-energizing the heat package time delay relay (s) and the blower.

LOCKOUT CIRCUITS

Each unit has two separate lockout circuits, one for the high pressure switch and one for the low pressure switch. Lockout circuits operate the same in either cooling or heating operation.

High pressure lockout circuit: Consists of a normally closed switch and an impedance circuit. As long as the switch is closed the circuit “R” to “Y” which controls the compressor contactor is complete. If the pressure rises above the set point of the switch (approximately 355 PSIG) the switch will open and the impedance circuit will lockout the circuit even after the pressure drops below the set point and switch closes. The circuit will remain in lockout until the thermostat system switch is set in the OFF position and all low voltage to the control circuit is off.

Low pressure lockout circuit: Consists of a normally open switch and a relay used in a latching circuit. As long as the switch is open the circuit “R” to “Y” which controls the compressor contactor is complete. If the pressure drops below the set point of the switch (approximately 15 to 27 PSIG) the switch will *close* and the relay will lockout the circuit even after the pressure rises above the set point and switch opens. The circuit will remain in lockout until the thermostat system switch is set in the OFF position and all low voltage to the control circuit is off.

PRESSURE SERVICE PORTS

High and low pressure service ports are installed on all units so that the system operating pressures can be observed. Pressure tables can be found later in the manual covering all models. It is imperative to match the correct pressure table to the unit by model number.

SYSTEM START-UP

- Step 1 – Close disconnect switch(es) and set the thermostat to cool and the temperature to the highest setting.
- Step 2 – Check for proper airflow across the indoor coil.
- Step 3 – Connect the service gauges and allow the unit to run for at least 10 minutes or until pressures are stable. Check pressures to the system pressure table attached to the unit service panel.
- Step 4 – Fill out Ground Source Heat Pump Performance Report.

FIGURE 13

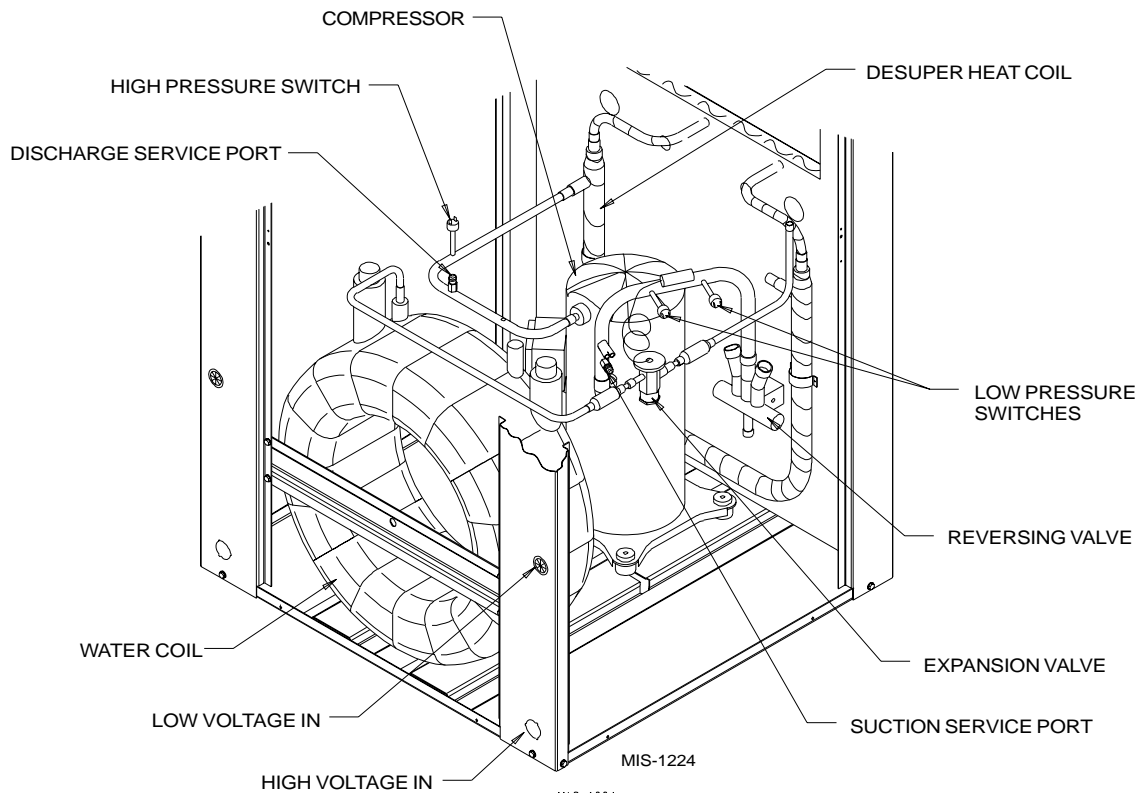

**FIGURE 14
CONTROL PANEL**

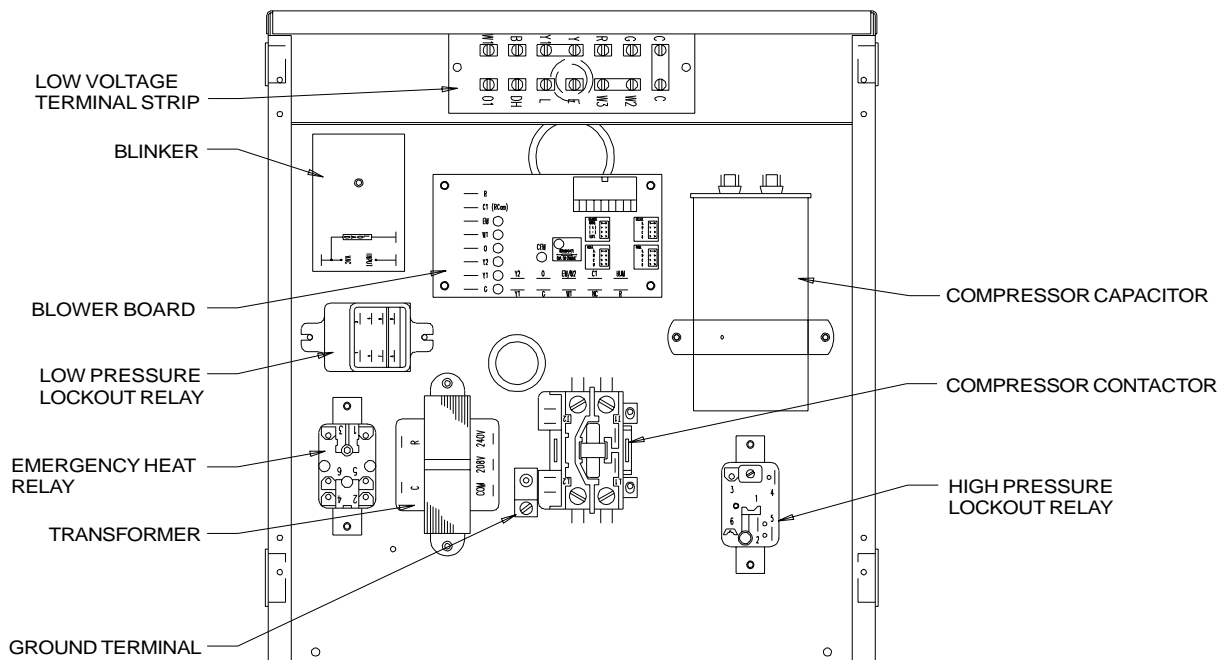
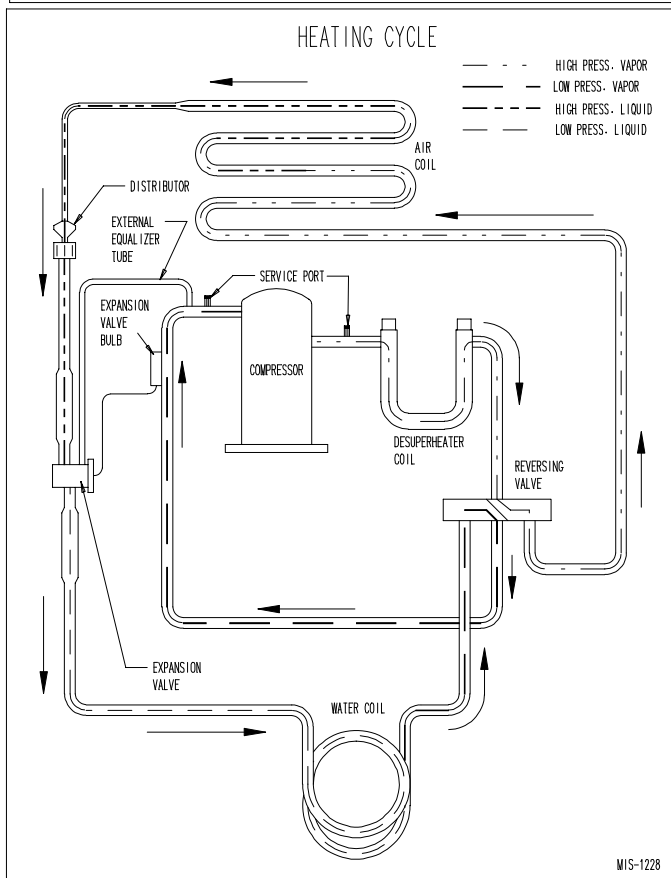
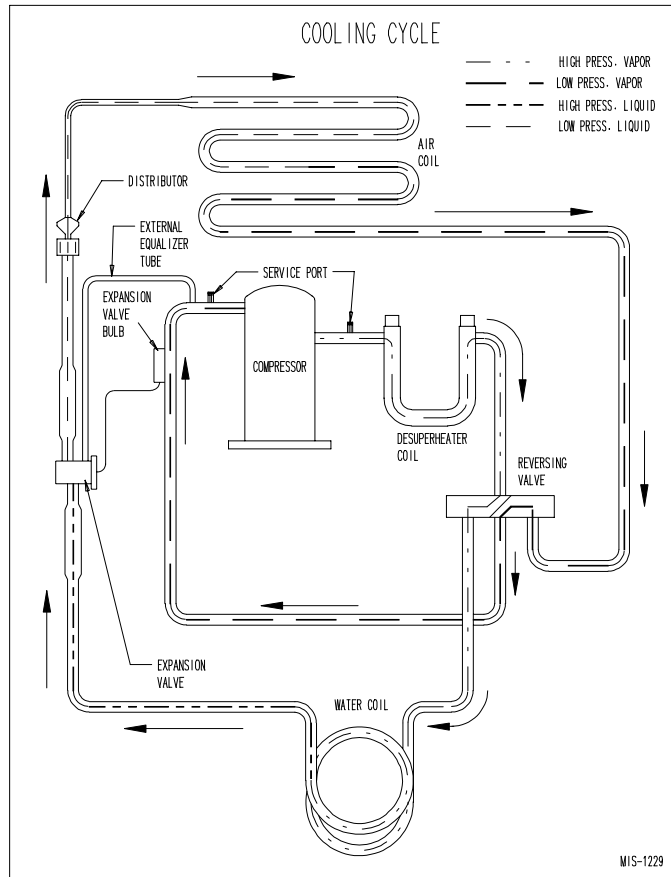

FIGURE 15



**FIGURE 16
PRESSURE TABLES**

COOLING

Fluid Temperature Entering Water Coil Degree F

Model	Return Air Temperature	Pressure	45	50	55	60	65	70	75	80	85	90	95	100	105	110
GSVS241-A	75 deg. DB 62 deg. WB	Low Side	74	75	76	77	78	79	80	81	82	83	84	85	86	87
		High Side	116	128	140	151	163	175	186	198	210	221	233	245	256	268
	80 deg. DB 67 deg. WB	Low Side	79	80	81	82	83	84	85	87	88	89	90	91	92	93
		High Side	119	131	143	155	167	179	191	203	215	227	239	251	263	275
	85 deg. DB 72 deg. WB	Low Side	85	86	87	88	89	90	91	93	94	95	96	97	98	99
		High Side	124	136	148	161	173	186	198	210	223	235	248	260	273	285
GSVS301-A	75 deg. DB 62 deg. WB	Low Side	72	73	74	75	76	77	78	79	80	81	82	83	84	85
		High Side	114	125	136	146	157	168	179	189	200	211	222	232	243	254
	80 deg. DB 67 deg. WB	Low Side	77	78	79	80	81	82	83	84	85	86	87	88	89	90
		High Side	117	128	139	150	161	172	184	195	206	217	228	239	250	261
	85 deg. DB 72 deg. WB	Low Side	83	84	85	86	87	88	89	90	91	92	93	94	95	96
		High Side	120	132	144	155	167	179	190	202	214	225	237	249	260	272
GSVS361-A	75 deg. DB 62 deg. WB	Low Side	69	70	71	72	73	74	75	77	78	79	80	81	82	83
		High Side	112	123	134	145	156	167	179	189	201	212	223	234	245	256
	80 deg. DB 67 deg. WB	Low Side	74	75	76	77	78	79	80	81	82	83	84	85	86	87
		High Side	115	126	137	149	160	172	183	195	206	218	229	241	252	264
	85 deg. DB 72 deg. WB	Low Side	80	81	82	83	84	85	86	87	88	89	90	91	92	93
		High Side	118	130	142	154	166	178	190	202	214	226	238	250	262	274
GSVS421-A	75 deg. DB 62 deg. WB	Low Side	69	70	71	72	73	74	75	76	77	78	79	80	81	82
		High Side	126	137	148	159	170	181	193	204	215	226	237	248	259	270
	80 deg. DB 67 deg. WB	Low Side	74	75	76	77	78	79	80	81	82	83	84	85	86	87
		High Side	129	140	151	163	174	186	197	209	220	232	243	255	266	278
	85 deg. DB 72 deg. WB	Low Side	80	81	82	83	84	85	86	87	88	89	90	91	92	93
		High Side	133	145	157	169	181	192	204	216	228	240	252	264	275	287

HEATING

Fluid Temperature Entering Water Coil Degree F

Model	Return Air Temperature	Pressure	25	30	35	40	45	50	55	60	65	70	75	80
GSVS241-A	70 deg. DB	Low Side	38	43	48	53	58	63	68	73	78	83	88	93
		High Side	169	175	180	186	191	197	203	208	214	219	225	230
GSVS301-A	70 deg. DB	Low Side	35	40	45	50	56	61	66	72	77	82	87	93
		High Side	181	187	194	201	207	214	221	227	234	241	247	254
GSVS361-A	70 deg. DB	Low Side	33	38	43	48	53	58	63	68	73	78	83	88
		High Side	177	183	189	196	202	208	214	220	226	232	239	245
GSVS421-A	70 deg. DB	Low Side	30	35	40	45	50	55	60	65	70	75	80	85
		High Side	192	199	205	211	217	223	229	235	241	247	254	260

7960-406

QUICK REFERENCE TROUBLESHOOTING CHART FOR WATER TO AIR HEAT PUMP

● Denotes common cause
 ✕ Denotes occasional cause

	POWER SUPPLY														WATER COIL SECTION													INDOOR SECTION		AUX.																										
	Line Voltage							Control Circuit							Compressor			Refrigerant System						Water Solenoid	Rev. Valve	Water Coil					Indoor Blower Motor and Coil		Heat	Gen.																						
	Power Failure	Blown Fuse or Tripped Breaker	Faulty Wiring	Loose Terminals	Low Voltage	Defective Contacts in Contactor	Compressor Overload	Potential Relay	Run Capacitor	Start Capacitor	Faulty Wiring	Loose Terminals	Control Transformer	Low Voltage	Thermostat	Contactor Coil	Pressure Controls (High or Low)	Indoor Blower Relay	Discharge Line Hitting Inside of Shell	Bearings Defective	Seized	Valve Defective	Motor Windings Defective	Refrigerant Charge Low	Refrigerant Overcharge	High Head Pressure	Low Head Pressure	High Suction Pressure	Low Suction Pressure	Non-Condensables	Unequalized Pressures	Solenoid Valve Stuck Closed (Htg)	Solenoid Valve Stuck Closed (Clg)	Solenoid Valve Stuck Open (Htg or Clg)	Leaking	Defective Valve or Coil	Plugged or Restricted Metering Device (Htg)	Scaled or Plugged Coil (Htg)	Scaled or Plugged Coil (Clg)	Water Volume Low (Htg)	Water Volume Low (Clg)	Low Water Temperature (Htg)	Plugged or Restricted Metering Device (Clg)	Fins Dirty or Plugged	Motor Winding Defective	Air Volume Low	Air Filters Dirty	Undersized or Restricted Ductwork	Auxiliary Heat Upstream of Coil							
Heating or Cooling Cycles	Compressor Will Not Run	●	●	●	●	+	+			●	●	●	+	+	●	●																																								
	No Power at Contactor	●	●	●	●																																																			
	Compressor Will Not Run Power at Contactor			●	●	●			●	●	●									+	●		●																																	
	Compressor "Hums" But Will Not Start			●	●	+			●	●	●										●	●	●																																	
	Compressor Cycles on Overload			●	●	+	●		●	●	●											+	+	●	●	+	+	●																												
	Thermostat Check Light Lite-Lockout Relay																●																																							
	Compressor Off on High Pressure Control																+	●							●																															
	Compressor Off on Low Pressure Control																+							●																																
	Compressor Noisy																			+	+	●																																		
	Head Pressure Too High																								●																															
	Head Pressure Too Low																						●																																	
	Suction Pressure Too High																						●																																	
	Suction Pressure Too Low																								●																															
	I.D. Blower Will Not Start	●	●	●	●						●	●	●	+	+		●																																							
I.D. Coil Frosting or Icing																							●																																	
High Compressor Amps				●				●													●	●	+	●	●	●	●	●																												
Excessive Water Usage																																																								
Cooling Cycle	Compressor Runs Continuously - No Cooling																				●		●																																	
	Liquid Refrigerant Flooding Back To Compressor																							●	●																															
Heating Cycle	Compressor Runs Continuously - No Heating																				●		●																																	
	Reversing Valve Does Not Shift			●	●																			+																																
	Liquid Refrigerant Flooding Back To Compressor																								●	●																														
	Aux. Heat on I.D. Blower Off			●	●						●	●		+			●																																							
Excessive Operation Costs			+	+									+											●	●																															
Ice in Water Coil			+	+																				●																																

SERVICE

SERVICE HINTS

1. Caution homeowner to maintain clean air filters at all times. Also, not to needlessly close off supply and return air registers. This reduces air flow through the system, which shortens equipment service life as well as increasing operating costs.
2. Check all power fuses or circuit breakers to be sure that they are the correct rating.

UNBRAZING SYSTEM COMPONENTS

If the refrigerant charge is removed from a scroll equipped unit by bleeding the high side only, it is sometimes possible for the scrolls to seal, preventing pressure equalization through the compressor. This may leave low side shell and suction line tubing pressurized. If the brazing torch is then applied to the low side while the low side shell and suction line contains pressure, the pressurized refrigerant and oil mixture could ignite when it escapes and contacts the brazing flame. To prevent this occurrence, it is important to check both the high and low side with manifold gauges before unbrazing.

WARNING

Both the high and low side of the scroll compressor must be checked with manifold gauges before unbrazing system components. Failure to do so could cause pressurized refrigerant and oil mixture to ignite if it escapes and contacts the brazing flame causing property damage, bodily harm or death.

TROUBLESHOOTING ECM BLOWER MOTORS



CAUTION

Disconnect power from unit before removing or replacing connectors, or servicing motor. Wait at least 5 minutes after disconnection power before opening motor.

SYMPTOM

Motor rocks slightly when starting.

Motor won't start

- No movement

- Motor rocks, but won't start

Motor oscillates up and down while being tested off of blower

- Noisy blower of cabinet

- "Hunts" or "puffs" at high CFM (speed)

Evidence of Moisture

- Motor failure or malfunction has occurred and moisture is present
- Evidence of moisture present inside air mover

DO

- Check out motor, controls, wiring and connections thoroughly before replacing motor
- Orient connectors down so water can't get in; install "drip loops"
- Use authorized motor and control model numbers for replacement
- Keep static pressure to a minimum:
 - Recommend high efficiency, low static filters
 - Recommend keeping filters clean
 - Design duct work for minimum static, maximum comfort
 - Look for and recommend duct work improvement, where necessary, in replacement.

CAUSE / PROCEDURE

- This is normal start-up for ICM

- Check power at motor
- Check low voltage (24 VAC R to C) at motor
- Check low voltage connections (G, Y, W, R, C) at motor
- Check for unseated pins in connectors on motor harness
- Test with a temporary jumper between R - G
- Check motor for tight shaft
- Run **Mositure Check**
- Check for loose or compliant motor mount
- Make sure blower wheel is tight on shaft

- It is normal for motor to oscillate with no load on shaft.
- Check for loose blower housing, panels, etc.
- High static creating high blower speed?
 - Check for air whistling through seams in ducts, cabinets or panels.
 - Check for cabinet / duct deformation
- Does removing panel or filter reduce "puffing"?
 - Reduce restriction
 - Reduce maximum airflow

- Replace motor and perform **Moisture Check**

- Perform Moisture Check

DON'T

- Automatically assume the motor is bad
- Locate connectors above 7 and 4 o'clock positions
- Replace one motor of control model number with another (unless an authorized replacement)
- Use high pressure drop filters. Some have 1/2" H₂O drop!
- Use restricted returns

SYMPTOM

Motor starts but runs erratically

- Varies up and down or intermittent
- "Hunts" or puffs" at high CRM (speed)
- Stays at low CFM despite system call for cool or heat CFM
- Stays at high CFM
- Blower won't shut off

SYMPTOM

Excessive noise

- Air Noise

DO

- Size the equipment wisely
- Check orientation before inserting motor connectors

MOISTURE CHECK PROCEDURE

- Connectors are oriented "down"
- Arrange harnesses with "drip loop" under motor
- Condensate drain plugged?
- Check for low airflow (too much latent capacity)
- Check for undercharged condition
- Check and plug leaks in return ducts and cabinet

CAUSE / PROCEDURE

- Check line voltage for variation or "sag"
- Check low voltage connections (G, Y, W, R, C) at motor; unseated pins in motor harness connectors
- Check "Bk" for erratic CFM command (in variable speed applications)
- Check out system controls - thermostat?
- Perform **Moisture Check**
- Does removing panel or filter reduce "puffing"?
 - Reduce restriction
 - Reduce maximum airflow
- Check low voltage (thermostat) wires and connections
- Verify fan is not in delay mode - wait until delay is complete
- "R" missing / not connected at motor
Perform motor / control replacement check
- "R" missing / not connected at motor
- Is fan in delay mode? - wait until delay time complete
- Current leakage from controls into G, Y or W?
 - Check for Triac switched thermostat or solid state relay

CAUSE / PROCEDURE

- Determine if it is air noise, cabinet, duct or motor noise . Interview customer if necessary.
- High static creating high blower speed?
 - Is airflow set properly?
 - Does removing filter cause blower to slow down?
Check / replace filter
 - Use low pressure drop filter
 - Check / correct duct restrictions

DON'T

- Oversize system then compensate with low airflow
- Plug in power connector backwards
- Force plugs

COMFORT CHECK PROCEDURE

- Check proper airflow settings
- Low static pressure for lowest noise
- Set low continuous fan CFM
- Use humidistat and 2-speed cooling units
- Use zoning controls designed for ICM that regulate CFM
- Thermostat in bad location?

ADD-ON DPM26A PUMP MODULE KIT

NOTE: This section applies only if a DPM26A Pump Module is added. Refer to DPM26A instructions for complete installation details.

GENERAL

This high efficiency water source heat pump series was designed with a refrigerant to water heat exchanger commonly known as a desuperheater coil factory-installed for ease in installing optional DPMA pump module kit. The addition of this optional kit allows for heat recovery for hot water heating when connected to a home water heater. The amount of annual hot water supplied and thus additional energy cost savings will depend on the amount of hot water usage and the number of hours the heat pump operates. This pump kit is suitable for potable water.

INSTALLATION

1. Follow all local, state, and national codes applicable to the installation of the pump module kit.
2. Follow the installation instructions received with the DPM26A pump module kit.
3. Connect the water lines between the unit, pump module kit, and the water heater.

FIGURE 17

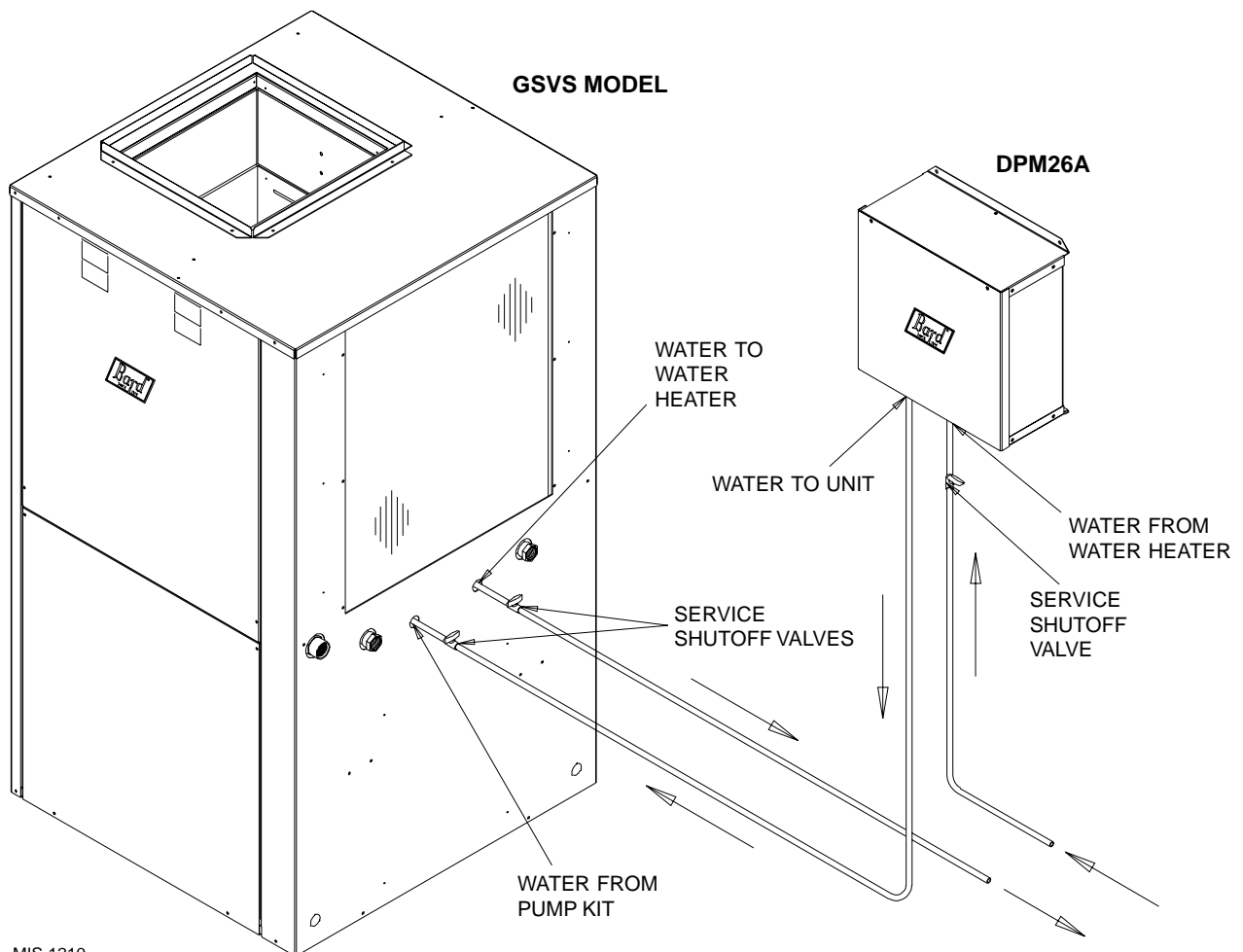

MIS-1210

GROUND SOURCE HEAT PUMP PERFORMANCE REPORT

This performance check report should be filled out by installer and retained with unit.

DATE _____ TAKEN BY: _____

1. UNIT:
Mfgr _____ Model No. _____ S/N _____

THERMOSTAT:
Mfgr _____ Model No. _____ P/N _____

2. Person Reporting _____

3. Company Reporting _____

4. Installed By _____ Date Installed _____

5. User's (Owner's) Name _____
Address _____

6. Unit Location _____

WATER SYSTEM INFORMATION

7. Open Loop System (Water Well) _____ Closed Loop System _____

A. If Open Loop where is water discharged? _____

8. The following questions are for **Closed Loop systems only**

A. Closed loop system designed by _____

B. Type of antifreeze used _____ % Solution _____

C. System type: Series _____ Parallel _____

D. Pipe material _____ Nominal Size _____

E. Pipe Installed:

1. Horizontal _____ Total length of pipe _____ ft

No. pipes in trench _____ Depth bottom pipe _____ ft

2. Vertical _____ Total length of bore hole _____ ft

THE FOLLOWING INFORMATION IS NEEDED TO CHECK PERFORMANCE OF UNIT.

	Cooling	** Heating	
FLUID SIDE DATA			
9. Entering fluid temperature	_____	_____	F
10. Leaving fluid temperature	_____	_____	F
11. Entering fluid pressure	_____	_____	PSIG
12. Leaving fluid pressure	_____	_____	PSIG
13. Pressure drop through coil	_____	_____	PSIG
14. Gallons per minute through the water coil	_____	_____	GPM
15. Liquid or discharge line pressure	_____	_____	PSIG
16. Suction line pressure	_____	_____	PSIG
17. Voltage at compressor (unit running)	_____	_____	V
18. Amperage draw at line side of contactor	_____	_____	A
19. Amperage at compressor common terminal	_____	_____	A
20. * Suction line temperature 6" from compressor	_____	_____	F
21. * Superheat at compressor	_____	_____	F
22. * Liquid line temperature at metering device	_____	_____	F
23. * Coil subcooling	_____	_____	F
 INDOOR SIDE DATA			
24. Dry bulb temperature at air entering indoor coil	_____	_____	F
25. Wet bulb temperature of air entering indoor coil	_____	_____	F
26. Dry bulb temperature of air leaving indoor coil	_____	_____	F
27. Wet bulb temperature of air leaving indoor coil	_____	_____	F
28. * Supply air static pressure (packaged unit)	_____	_____	WC
29. * Return air static pressure (packaged unit)	_____	_____	WC
30. Other information about installation			
	_____	_____	
	_____	_____	
	_____	_____	
	_____	_____	
	_____	_____	
	_____	_____	
	_____	_____	

** When performing a heating test insure that 2nd stage heat is not activated
 * Items that are optional

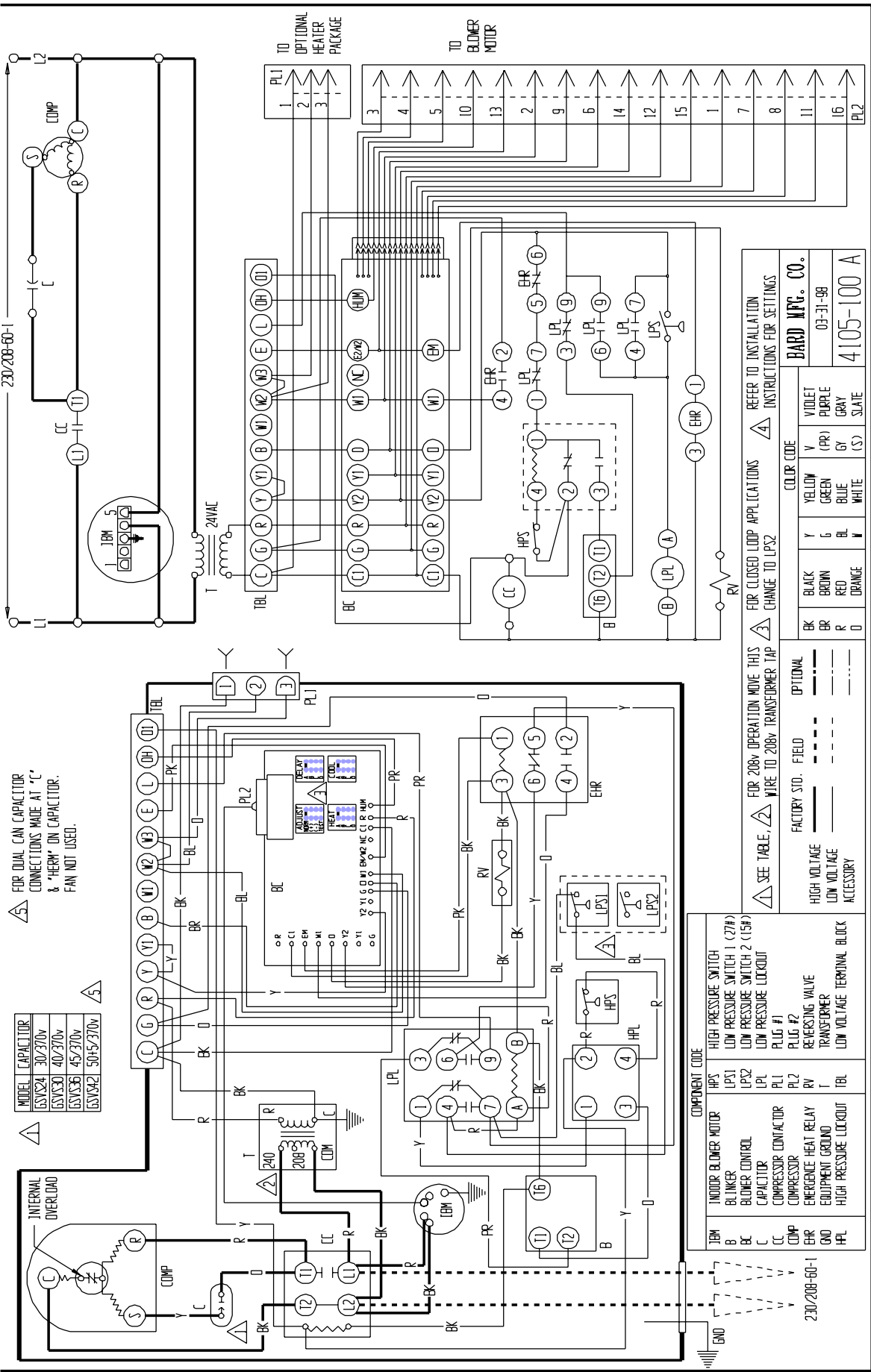

FOR DUAL CAN CAPACITOR CONNECTIONS MADE AT 'C' & 'HERM' ON CAPACITOR. FAN NOT USED.

MODEL	CAPACITOR
GSV24	30/370v
GSV30	40/370v
GSV36	45/370v
GSV42	50+5/370v

COMPONENT CODE	DESCRIPTION
JBM	INDOOR BLOWER MOTOR
B	HIGH PRESSURE SWITCH 1 (27#)
BC	LOW PRESSURE SWITCH 2 (15#)
C	LOW PRESSURE LOCKOUT
CC	COMPRESSOR CONTACTOR
COMP	COMPRESSOR
EHR	EMERGENCY HEAT RELAY
END	REVERSING VALVE
HPL	TRANSFERMER
	LOW VOLTAGE TERMINAL BLOCK

FOR CLOSED LOOP APPLICATIONS	FOR 208v OPERATION MOVE THIS WIRE TO 208v TRANSFORMER TAP	FOR 208v TRANSFORMER TAP	FOR CLOSED LOOP APPLICATIONS CHANGE TO LPS2	REFER TO INSTALLATION INSTRUCTIONS FOR SETTINGS
△	△	△	△	△

COMPONENT CODE	COLOR CODE
BK	BLACK
BR	BROWN
R	RED
O	ORANGE
Y	YELLOW
G	GREEN
BL	BLUE
W	WHITE
PR	PURPLE
VI	VIOLET
GR	GRAY
SL	SLATE

FACTORY STD.	FIELD	OPTIONAL
---	---	---
---	---	---
---	---	---
---	---	---

COMPONENT CODE	DESCRIPTION
HPS	HIGH PRESSURE SWITCH
LPS1	LOW PRESSURE SWITCH 1 (27#)
LPS2	LOW PRESSURE SWITCH 2 (15#)
LPL	LOW PRESSURE LOCKOUT
PL1	PLUG #1
PL2	PLUG #2
RV	REVERSING VALVE
T	TRANSFERMER
TBL	LOW VOLTAGE TERMINAL BLOCK

230/208-60-1