

INSTALLATION INSTRUCTIONS

WATER SOURCE HEAT PUMPS

Models: **GSVS242-A, GSVS302-A**
GSVS361-A, GSVS421-A
GSVS481-A, GSVS601-A

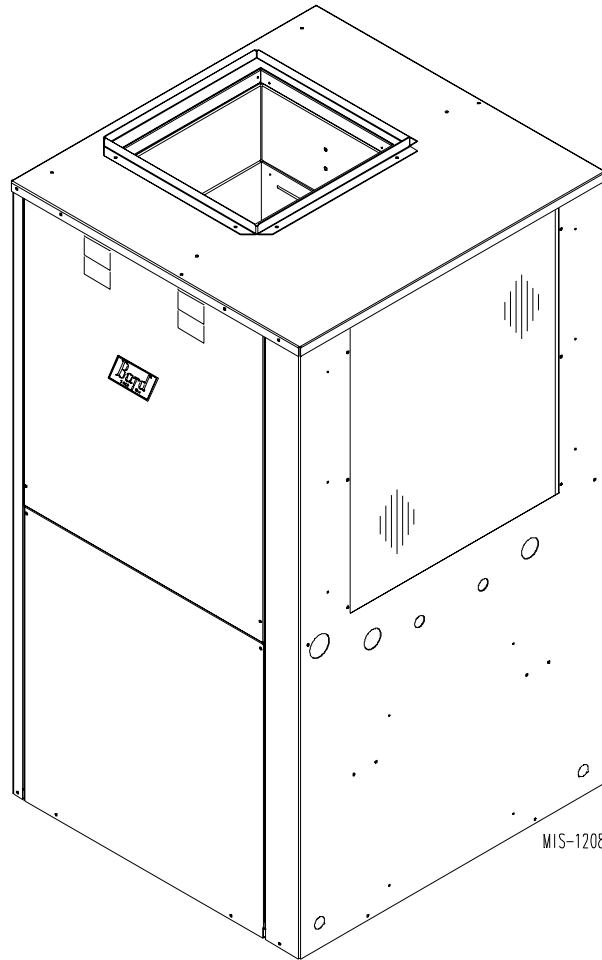

Earth Loop Fluid
Temperatures 25° - 110°
Ground Water Temperatures 45° - 75°



CLIMATE CONTROL SOLUTIONS

Bard Manufacturing Company, Inc.
Bryan, Ohio 43506
Since 1914...Moving ahead, just as planned.

Manual: 2100-317H
Supersedes: 2100-317G
File: Volume I, Tab 8
Date: 12-20-06

CONTENTS

Getting Other Informations and Publications 3

General Information

| | |
|-----------------------------------|---|
| Water Source Nomenclature | 4 |
| Heater Package Nomenclature | 8 |

Application and Location

| | |
|-----------------------------|----|
| General | 9 |
| Shipping Damage | 9 |
| Application | 9 |
| Location | 9 |
| Ductwork | 9 |
| Filters | 11 |
| Condensate Drain | 11 |
| Piping Access to Unit | 11 |

Wiring Instructions

| | |
|------------------------------|---------|
| General | 13 |
| Control Circuit Wiring | 13 |
| Wall Thermostats | 13 |
| Thermostat Indicators | 14 |
| Emergency Heat Mode | 14 |
| Blower Control Setup | 14 |
| Humidity Control | 14 |
| CFM Light | 14 |
| Wiring Diagrams | 16 & 17 |

Closed Loop (Earth Coupled Ground Loop Applications)

| | |
|---|----|
| Note | 18 |
| Circulation System Design | 18 |
| Start Up Procedure for Closed Loop System | 19 |

Open Loop (Well System Applications)

| | |
|---|---------|
| Note | 21 |
| Water Connection | 21 |
| Well Pump Sizing | 21 & 22 |
| Start Up Procedure for Open Loop System | 23 |
| Water Corrosion | 23 & 24 |
| Remedies of Water Problems | 24 |
| Lake and/or Pond Installations | 24 & 25 |

Sequence of Operation

| | |
|---|-------|
| Blower | 26 |
| Cooling | 26 |
| Heating Without Electric Heat | 26 |
| Heating With Electric Heat | 26 |
| Emergency Heat | 26 |
| Lockout Circuits | 26 |
| Pressure Service Ports | 26 |
| System Start Up | 26 |
| Pressure Tables | 29-30 |
| Quick Reference Troubleshooting Chart | 31 |

Service

| | |
|--------------------------------------|---------|
| Service Hints | 32 |
| Unbrazing System Components | 32 |
| Troubleshooting GE ECM™ Motors | 33 & 34 |

Accessories

| | |
|-------------------------------------|----|
| Add-On DPM26A Pump Module Kit | 35 |
| General | 35 |
| Installation | 35 |

Ground Source Heat Pump

Performance Report 36-37

Wiring Diagrams 38-39

Figures

| | |
|--|----|
| Figure 1 Unit Dimensions | 7 |
| Figure 2 Field-Conversion to Left Hand Return .. | 10 |
| Figure 3A Filter Components GSVS24-42 Models . | 11 |
| Figure 3B Filter Components GSVS48-60 Models . | 11 |
| Figure 4 Piping Access | 12 |
| Figure 5 Blower Control Board | 15 |
| Figure 6 Circulation System Design | 18 |
| Figure 7 | 20 |
| Figure 8 Model GPM-1 Loop Pump Module | 20 |
| Figure 9 Model GPM-2 Loop Pump Module | 20 |
| Figure 10 Water Connection Components | 22 |
| Figure 11 Cleaning Water Coil | 24 |
| Figure 12 Lake or Pond Installation | 25 |
| Figure 13 | 27 |
| Figure 14 Control Panel | 27 |
| Figure 15 | 28 |
| Figure 16 Pressure Table Cooling | 29 |
| Figure 16A Pressure Table Heating | 30 |
| Figure 17 Control Disassembly | 34 |
| Figure 18 Winding Test | 34 |
| Figure 19 Drip Loop | 34 |
| Figure 20 Typical Pump Kit Connection (DPM26A) | 35 |

Tables

| | |
|--|----|
| Table 1 Indoor Blower Performance | 4 |
| Table 2 Flow Rates for Various Fluids | 5 |
| Table 3 Specifications | 5 |
| Table 4 Water Coil Pressure Drop | 6 |
| Table 5 Electrical Specifications Optional Field Installed Heater Package | 8 |
| Table 6 Control Circuit Wiring | 13 |
| Table 7 Wall Thermostat | 13 |
| Table 8 Blower Control Setup | 14 |
| Table 9 Constant Flow Valves | 21 |

GETTING OTHER INFORMATION AND PUBLICATIONS

These publications can help you install the air conditioner or heat pump. You can usually find these at your local library or purchase them directly from the publisher. Be sure to consult current edition of each standard.

National Electrical Code ANSI/NFPA 70

Standard for the Installation ANSI/NFPA 90A
of Air Conditioning and Ventilating Systems

Standard for Warm Air ANSI/NFPA 90B
Heating and Air Conditioning Systems

Load Calculation for Residential ACCA Manual J
Winter and Summer Air Conditioning

Duct Design for Residential ACCA Manual D
Winter and Summer Air Conditioning and Equipment
Selection

Closed-Loop/Ground Source Heat Pump IGSHPA
Systems Installation Guide

Grouting Procedures for Ground-Source IGSHPA
Heat Pump Systems

Soil and Rock Classification for IGSHPA
the Design of Ground-Coupled Heat Pump Systems

Ground Source Installation Standards IGSHPA

Closed-Loop Geothermal Systems IGSHPA
– Slinky Installation Guide

FOR MORE INFORMATION, CONTACT THESE PUBLISHERS:

ACCA Air Conditioning Contractors of America
1712 New Hampshire Avenue
Washington, DC 20009
Telephone: (202) 483-9370
Fax: (202) 234-4721

ANSI American National Standards Institute
11 West Street, 13th Floor
New York, NY 10036
Telephone: (212) 642-4900
Fax: (212) 302-1286

**ASHRAE American Society of Heating Refrigerating,
and Air Conditioning Engineers, Inc.**
1791 Tullie Circle, N.E.
Atlanta, GA 30329-2305
Telephone: (404) 636-8400
Fax: (404) 321-5478

NFPA National Fire Protection Association
Batterymarch Park
P.O. Box 9101
Quincy, MA 02269-9901
Telephone: (800) 344-3555
Fax: (617) 984-7057

**IGSHPA International Ground Source
Heat Pump Association**
490 Cordell South
Stillwater, OK 74078-8018

WATER SOURCE PRODUCT LINE NOMENCLATURE

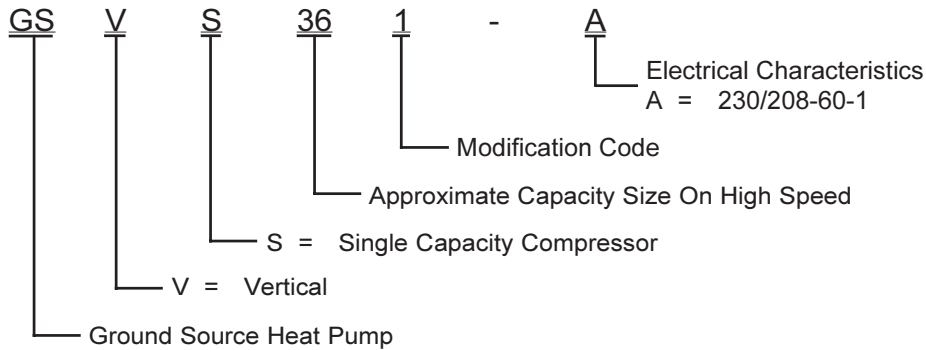

TABLE 1 ①
INDOOR BLOWER PERFORMANCE (RATED CFM)

| MODEL | Rated ESP | MAX EXP | ② Continuous Airflow | ③ Rated Cooling CFM | ④ Rated Heating CFM | Electric Heat CFM |
|---------|-----------|---------|----------------------|---------------------|---------------------|-------------------|
| GSVS242 | 0.10 | 0.60 | 500 | 800 | 800 | 1000 |
| GSVS301 | 0.15 | 0.60 | 550 | 1000 | 1000 | 1000 |
| GSVS361 | 0.15 | 0.60 | 625 | 1200 | 1200 | 1250 |
| GSVS421 | 0.20 | 0.60 | 675 | 1250 | 1250 | 1250 |
| GSVS481 | 0.20 | 0.60 | 800 | 1400 | 1400 | 1900 |
| GSVS601 | 0.20 | 0.60 | 900 | 1600 | 1600 | 1900 |

- ① Motor will deliver consistent CFM through voltage supply range with no deterioration (197-253V for all 230/208V models).
- ② Continuous CFM is the total air being circulated during continuous (manual fan) mode.
- ③ Will occur automatically with a call for “Y” for cooling mode operation.
- ④ Will occur automatically with a call for “W1” for heating mode operation.

EXCEPTION: The rated CFM maybe adjusted +/- 15%, see Table 8. The CFM light on the Blower Control Board can also be used to “count” the CFM of delivered air, see section on CFM light.

**TABLE 2
FLOW RATES FOR VARIOUS FLUIDS**

| VARIOUS FLUIDS | MODELS | | | | | | | |
|--|-----------|-----------|-----------|-----------|-----------|-----------|--|--|
| | GSVS242-A | GSVS302-A | GSVS361-A | GSVS421-A | GSVS481-A | GSVS601-A | | |
| Flow rate required GPM fresh water | 3 | 4 | 5 | 5 | 6 | 8 | | |
| Flow rate required GPM 15% Sodium Chloride | 5 | 6 | 7 | 8 | 9 | 12 | | |
| Flow rate required GPM 25% GS4 | 5 | 6 | 7 | 8 | 9 | 12 | | |

**TABLE 3
SPECIFICATIONS**

| MODEL | GSVS242-A | GSVS302-A | GSVS361-A | GSVS421-A | GSVS481-A | GSVS601-A |
|--------------------------------------|----------------|---------------|---------------|---------------|---------------|----------------|
| Electrical Rating (60ZVPH) | 230/208-1 | 230/208-1 | 230/208-1 | 230/208-1 | 230/208-1 | 230/208-1 |
| Operating Voltage Range | 253-197 | 253-197 | 253-197 | 253-197 | 253-197 | 253-197 |
| Minimum Circuit Ampacity | 15.0 | 17.0 | 20.0 | 24.0 | 26.0 | 35.0 |
| + Field Wire Size | #14 | #14 | #12 | #10 | #10 | #8 |
| ++ Delay Fuse Max or Circuit Breaker | 20 | 25 | 30 | 35 | 40 | 55 |
| Total Unit Amps 230/208 | 8.1 / 9.1 | 10.8 / 11.8 | 13.9 / 14.5 | 17.7 / 19.1 | 20 / 21 | 27 / 28 |
| COMPRESSOR | | | | | | |
| Volts | 230/208 | 230/208 | 230/208 | 230/208 | 230/208 | 230/208 |
| Rated Load Amps 230/208 | 6.5 / 7.5 | 8.5 / 9.5 | 11.0 / 11.6 | 14.2/15.6 | 17.5/18.5 | 23.5/24.6 |
| Branch Circuit Selection Current | 10.0 | 11.0 | 13.5 | 16.0 | 18.5 | 25.0 |
| Lock Rotor Amps 230/208 | 45 / 45 | 54 / 54 | 72.5 / 72.5 | 88 / 88 | 109 / 109 | 169 / 169 |
| BLOWER MOTOR and EVAPORATOR | | | | | | |
| Blower Motor – HP / Spd. | 1/2 / Variable | | | | | 3/4 / Variable |
| Blower Motor – Amps / CFM | 1.6 / 800 | 2.3 / 1000 | 2.9 / 1200 | 3.5 / 1250 | 2.5 / 1400 | 3.5 / 1600 |
| Face Area Sq. Ft./Rows/Fins Per Inch | 3.16 / 3 / 15 | 3.16 / 3 / 15 | 3.16 / 4 / 11 | 3.16 / 4 / 11 | 5.33 / 3 / 11 | 5.33 / 4 / 11 |

+ 75°C copper wire

++ HACR type circuit breaker

**TABLE 4
WATER COIL PRESSURE DROP**

| Model | GSVS242 | | GSVS302 | | GSVS361, GSVS421 | | GSVS481 | | GSVS601 | | |
|-------|---------|------|---------|------|---------------------|-------|---------|-------|---------|-------|---------|
| | GPM | PSIG | Ft. Hd. | PSIG | Ft. Hd. | PSIG | Ft. Hd. | PSIG | Ft. Hd. | PSIG | Ft. Hd. |
| 3 | 1.00 | 2.31 | --- | --- | --- | --- | --- | --- | --- | --- | --- |
| 4 | 1.42 | 3.28 | 1.00 | 2.31 | --- | --- | --- | --- | --- | --- | --- |
| 5 | 1.83 | 4.22 | 1.43 | 3.30 | 1.80 | 4.15 | --- | --- | --- | --- | --- |
| 6 | 2.24 | 5.17 | 1.86 | 4.29 | 3.28 | 7.57 | 2.87 | 6.62 | --- | --- | --- |
| 7 | 2.66 | 6.14 | 2.30 | 5.31 | 4.77 | 11.01 | 4.33 | 10.00 | --- | --- | --- |
| 8 | --- | --- | 2.73 | 6.30 | 6.26 | 14.46 | 5.75 | 13.28 | --- | --- | --- |
| 9 | --- | --- | --- | --- | 7.75 | 17.90 | 7.12 | 16.44 | 3.85 | 8.89 | --- |
| 10 | --- | --- | --- | --- | 9.24 | 21.34 | 8.44 | 19.50 | 4.77 | 11.01 | --- |
| 11 | --- | --- | --- | --- | --- | --- | 9.72 | 22.45 | 5.69 | 13.14 | --- |
| 12 | --- | --- | --- | --- | --- | --- | 10.95 | 25.29 | 6.61 | 15.26 | --- |
| 13 | --- | --- | --- | --- | --- | --- | --- | --- | 7.52 | 17.37 | --- |
| 14 | --- | --- | --- | --- | --- | --- | --- | --- | 8.43 | 19.47 | --- |
| 15 | --- | --- | --- | --- | --- | --- | --- | --- | 9.34 | 21.57 | --- |

FIGURE 1 – UNIT DIMENSIONS

| Units | Width | | Depth | | Supply | | Return | |
|--------------------|--------|----|--------|--------|--------|--------|--------|-------|
| | A | B | C | D | E | F | G | H |
| GSVS24 - 42 | 27-5/8 | 26 | 48 | 13-7/8 | 13-7/8 | 22-1/2 | 22-1/4 | 6-7/8 |
| GSVS48 - 60 | 32-5/8 | 27 | 55-5/8 | 17-7/8 | 17-7/8 | 25-1/4 | 30-1/4 | 7 |

| I | J | K | L | M | N | O | P | Q | R | S | T | U | V | W |
|-------|-------|--------|--------|-------|-------|-------|---|--------|--------|--------|-------|-------|-------|--------|
| 4-1/4 | 1-1/2 | 32 | 11-1/4 | 1-5/8 | 1-1/4 | 1-3/4 | 2 | 23-5/8 | 21-3/4 | 21 | 6-5/8 | 4-1/4 | 5-3/4 | 1-7/8 |
| 4-1/4 | 1-1/2 | 39-1/4 | 11-1/4 | 1-5/8 | 1-1/4 | 1-3/4 | 2 | 23-3/4 | 22 | 21-1/4 | 9-1/8 | 4-1/4 | 5-3/4 | 2-1/16 |

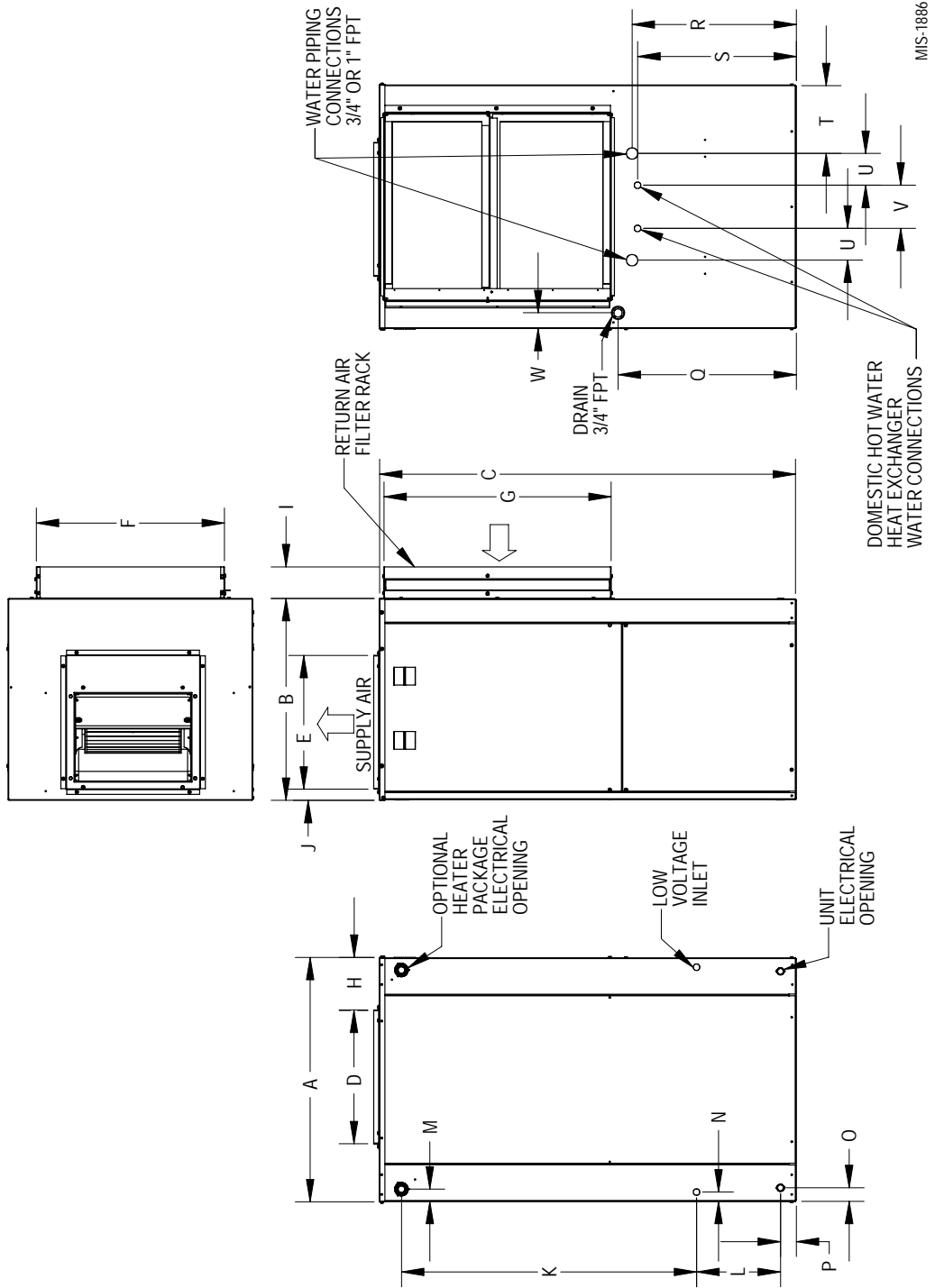

HEATER PACKAGE NOMENCLATURE

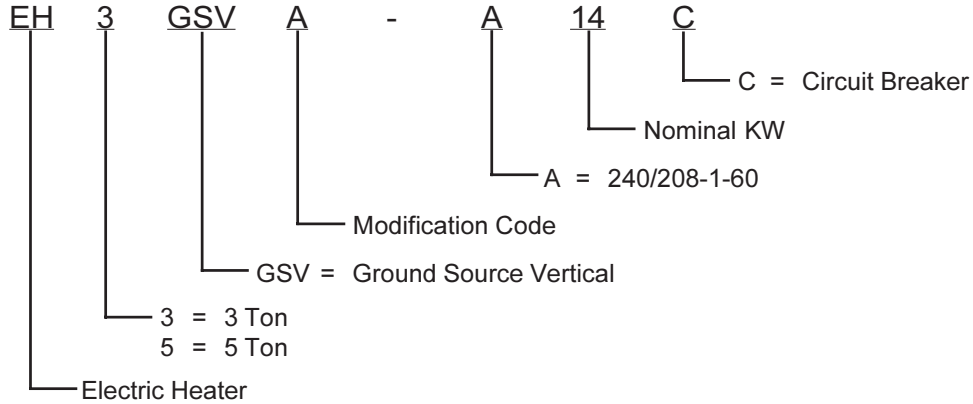

**TABLE 5
ELECTRICAL SPECIFICATIONS**

| Electrical Specifications - Optional Field-Installed Heater Packages (GSVS24-30-36-42 Only) | | | | | | | | | | | |
|---|--------------------------|----------------------------------|--|------|--------|--|-------|--------|--------------------------|------------------------------|------------------|
| For Use with GSVS Models | Heater Package Model No. | Heater Package Volts/Phase 60 HZ | Heater Amps, KW and Capacity @ 240 Volts | | | Heater Amps, KW and Capacity @ 208 Volts | | | Minimum Circuit Ampacity | Maximum HACR Circuit Breaker | Field Wire Size+ |
| | | | AMPS | KW | BTU | AMPS | KW | BTU | | | |
| GSVS24-A, 30-A, 36-A and 42-A | EH3GSVA-A05C | 240/208-1 | 18.8 | 4.5 | 15,345 | 16.3 | 3.38 | 11,525 | 23.5 | 25 | 10 |
| | EH3GSVA-A09C | 240/208-1 | 37.5 | 9.0 | 30,690 | 32.5 | 6.75 | 23,018 | 46.9 | 50 | 8 |
| | EH3GSVA-A14C | 240/208-1 | 56.3 | 13.5 | 46,035 | 48.7 | 10.13 | 34,543 | 70.4 | 80 | 4 |

| Electrical Specifications - Optional Field-Installed Heater Packages (GSVS48-60 Only) | | | | | | | | | | | |
|---|--------------------------|----------------------------------|--|------|--------|--|-------|--------|--------------------------|------------------------------|------------------|
| For Use with GSVS Models | Heater Package Model No. | Heater Package Volts/Phase 60 HZ | Heater Amps, KW and Capacity @ 240 Volts | | | Heater Amps, KW and Capacity @ 208 Volts | | | Minimum Circuit Ampacity | Maximum HACR Circuit Breaker | Field Wire Size+ |
| | | | AMPS | KW | BTU | AMPS | KW | BTU | | | |
| GSVS48-A and 60-A | EH5GSVA-A05C | 240/208-1 | 18.8 | 4.5 | 15,345 | 16.3 | 3.38 | 11,525 | 23.5 | 25 | 10 |
| | EH5GSVA-A09C | 240/208-1 | 37.5 | 9.0 | 30,690 | 32.5 | 6.75 | 23,018 | 46.9 | 50 | 8 |
| | EH5GSVA-A14C | 240/208-1 | 56.3 | 13.5 | 46,035 | 48.7 | 10.13 | 34,543 | 70.4 | 80 | 4 |
| | EH5GSVA-A18C | 240/208-1 | 75.0 | 18.0 | 61,380 | 64.9 | 13.5 | 46,035 | 98.3 | 100 | 3 |

+ Based on 75F copper wire. All wiring must conform to National Electrical Code (latest edition) and all local codes.

APPLICATION AND LOCATION

GENERAL

Units are shipped completely assembled and internally wired, requiring only duct connections, thermostat wiring, 230/208 volt AC power wiring, and water piping. The equipment covered in this manual is to be installed by trained, experienced service and installation technicians. Any heat pump is more critical of proper refrigerant charge and an adequate duct system than a cooling only air conditioning unit.

These instructions and any instructions packaged with any separate equipment required to make up the entire heat pump system should be carefully read before beginning the installation. Note particularly any tags and/or labels attached to the equipment.

While these instructions are intended as a general recommended guide, they do not in any way supersede any national and/or local codes. Authorities having jurisdiction should be consulted before the installation is made.

SHIPPING DAMAGE

Upon receipt of the equipment, the carton should be checked for external signs of shipping damage. If damage is found, the receiving party must contact the last carrier immediately, preferably in writing, requesting inspection by the carrier's agent.

APPLICATION

Capacity of the unit for a proposed installation should be based on heat loss calculations made in accordance with methods of the Air Conditioning Contractors of America, formerly National Warm Air Heating and Air Conditioning Association. The air duct system should be sized and installed in accordance with Standards of the National Fire Protection Association for the Installation of Air Conditioning and Venting systems of Other than Residence Type NFPA No. 90A, and residence Type Warm Air Heating and Air Conditioning Systems, NFPA No. 90B.

LOCATION

The unit may be installed in a basement, closet, or utility room provided adequate service access is insured. The unit is shipped from the factory as a right hand return and requires **access clearance of two feet minimum to the access panels on this side of the unit.** If unit is to be field converted to left hand return the opposite side will require access clearance of two feet minimum.

Unit may be field converted to left hand return by removing four (4) screws that secure the control panel cover, removing two (2) screws that hold the control panel in place, sliding the control panel through the

compressor compartment and re-securing the control panel on the opposite side of the water coil. (See Figure 2.) The two (2) access doors from the right hand return can be transferred to the left-hand return side and the one (1) left hand panel can be transferred to the right hand side.

Unit casing suitable for 0 inch clearance with 1-inch duct clearance for at least the first 4 feet of duct. These units are not approved for outdoor installation and therefore must be installed inside the structure being conditioned. ***Do not locate in areas subject to freezing in the winter or subject to sweating in the summer.***

Before setting the unit, consider ease of piping, drain and electrical connections for the unit. Also, for units which will be used with a field installed heat recovery unit, consider the proximity of the unit to the water heater or storage tank. Place the unit on a solid base, preferably concrete, to minimize undesirable noise and vibration. ***DO NOT*** elevate the base pan on rubber or cork vibration eliminator pads as this will permit the unit base to act like a drum, transmitting objectionable noise.

DUCTWORK

If the unit is to be installed in a closet or utility room which does not have a floor drain, a secondary drain pan under the entire unit is highly recommended.

DO NOT install the unit in such a way that a direct path exists between any return grille and the unit. Rather, insure that the air entering the return grille will make at least one turn before entering the unit or coil. This will reduce possible objectionable compressor and air noise from entering the occupied space.

Design the ductwork according to methods given by the Air Conditioning Contractors of America. When duct runs through unconditioned spaces, it should be insulated with vapor barrier. It is recommended that flexible connections be used to connect the ductwork to the unit in order to keep the noise transmission to a minimum.

WARNING

Failure to provide the 1-inch clearance between the supply duct and a combustible surface for the first 3 feet of duct can result in a fire.

FIGURE 2
FIELD-CONVERSION TO LEFT HAND RETURN

REMOVE SINGLE AND
 DOUBLE DOORS

- ① REMOVE 4 SCREWS SECURING COVER
- ② REMOVE 2 SCREWS HOLDING CONTROL BOX TO CORNER PANEL
 REMOVE 2 SCREWS SECURING PANEL TO BASE.
- ③ PASS CONTROL PANEL THROUGH COMPRESSOR SECTION
- ④ RE-SECURE CONTROL PANEL ON OPPOSITE SIDE IN SAME MANNER AS ORIGINALLY ATTACHED

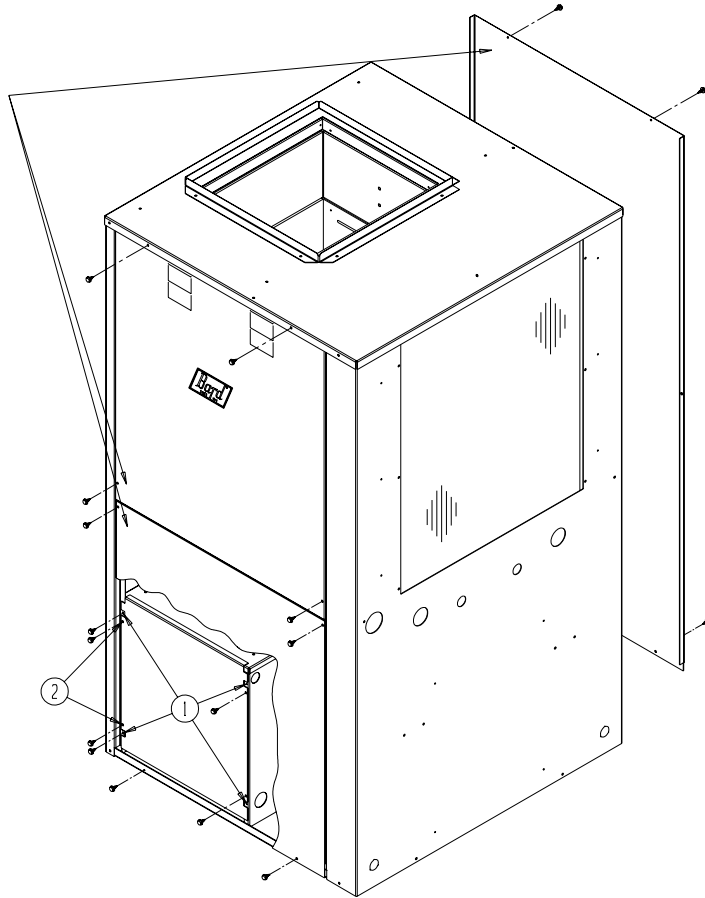

REPOSITION DOORS SO DOUBLE DOORS
 ARE ON CONTROL PANEL SIDE, AND
 SINGLE DOOR ON OPPOSITE SIDE

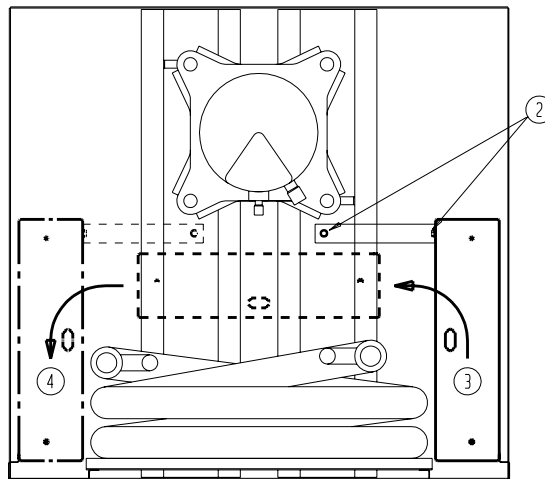

TOP VIEW

MIS-1209

FILTER

This unit must not be operated without a filter. It comes equipped with disposable filters, which should be checked often and replaced if dirty. Insufficient airflow due to undersized duct systems or dirty filters can result in nuisance tripping of the high or low pressure control. Refer to Table 2 for correct airflow and static pressure requirements. (See Figures 3A & 3B.)

CONDENSATE DRAIN

Determine where the drain line will run. This drain line contains cold water and must be insulated to avoid droplets of water from condensing on the pipe and dripping on finished floors or the ceiling under the unit. A trap *MUST BE* installed in the drain line and the trap

filled with water prior to start up. The use of plugged tees in place of elbows to facilitate cleaning is highly recommended.

Drain lines must be installed according to local plumbing codes. It is not recommended that any condensate drain line be connected to a sewer main. The drain line enters the unit through the 3/4" FPT coupling on the coil side of the unit.

PIPING ACCESS TO UNIT

Water piping to and from the unit enters the unit casing from the coil side of the unit under the return air filter rack. Piping connections are made directly to the unit and are 3/4" FPT for models 24 - 42, and 1" FPT for models 48-60. (See Figure 4.)

**FIGURE 3A
GSVS24 - 42 MODELS**

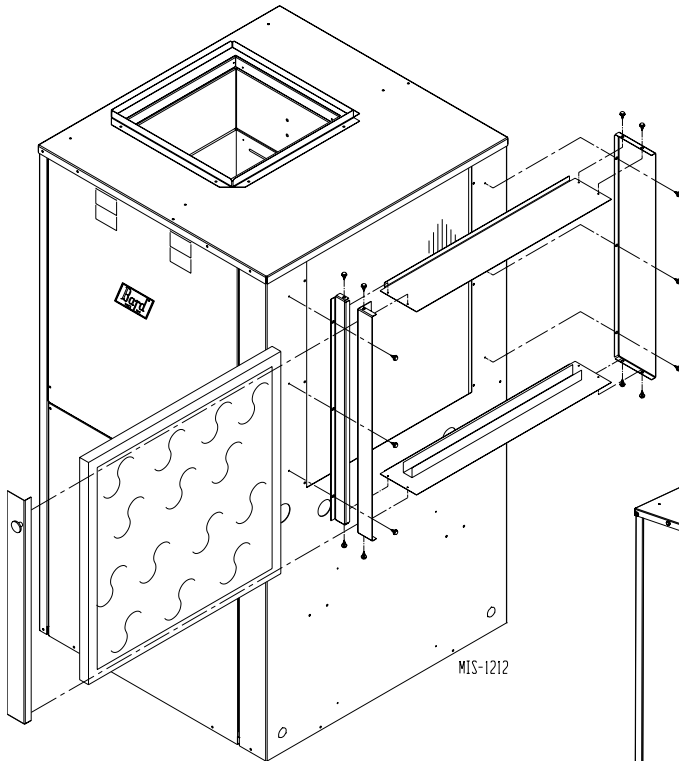

**FIGURE 3B
GSVS48 - 60 MODELS**

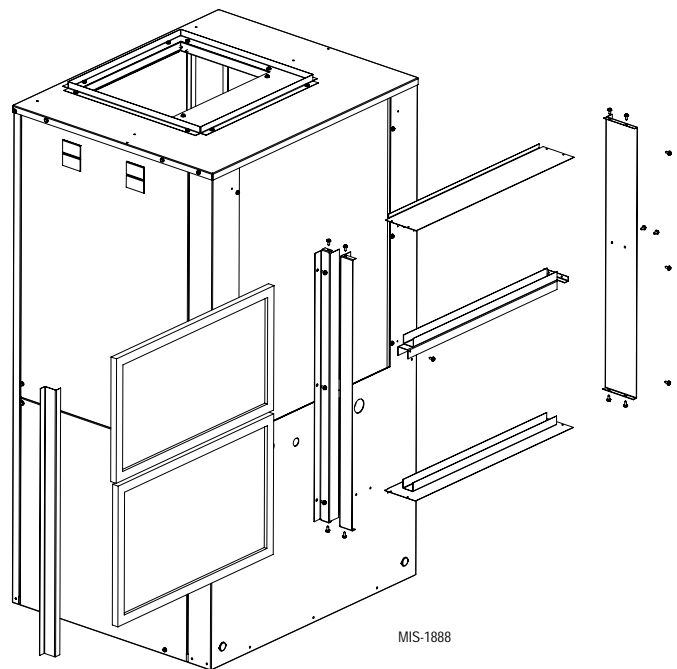

**FIGURE 4
PIPING ACCESS TO UNIT**

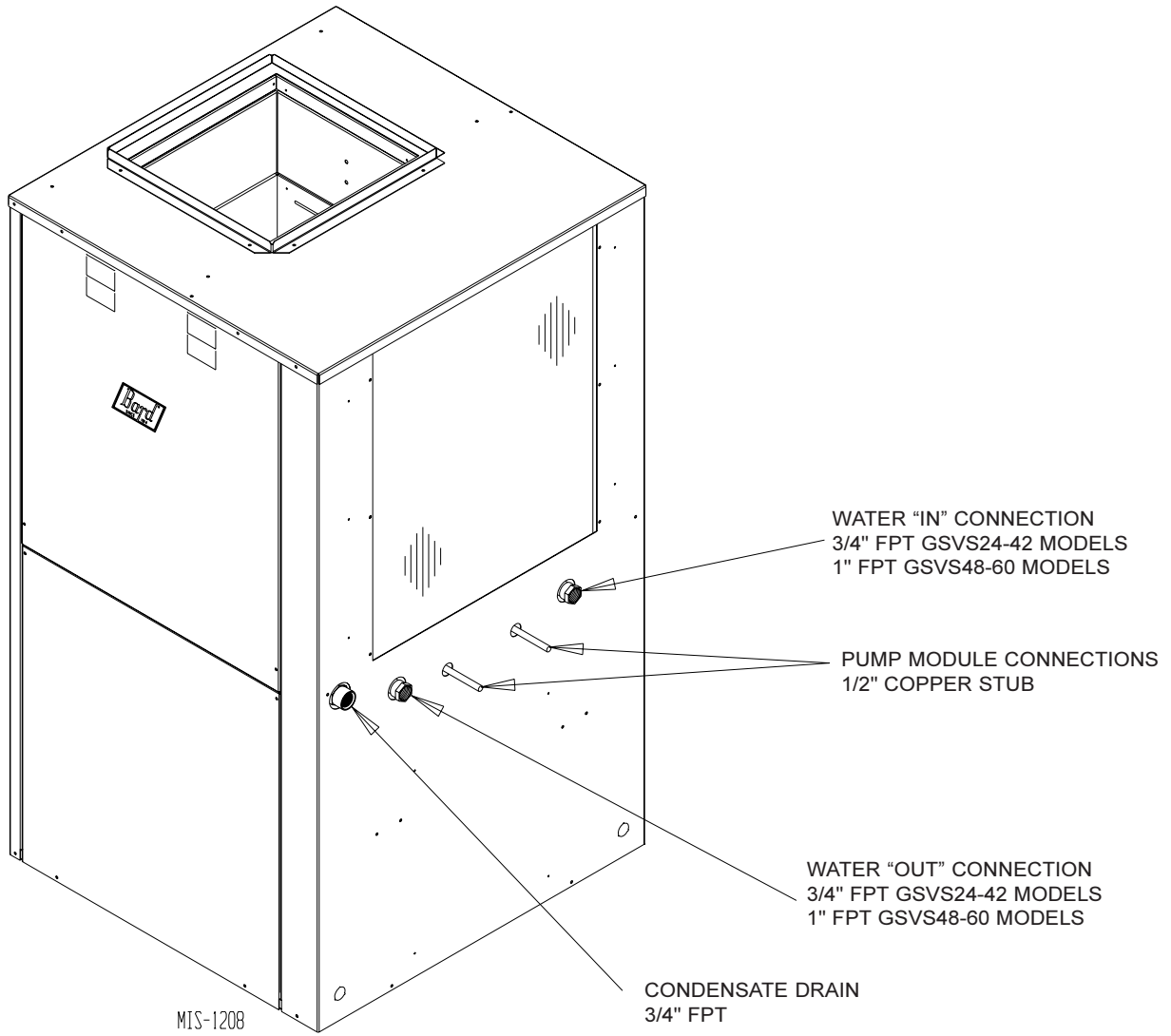

WIRING INSTRUCTIONS

GENERAL

All wiring must be installed in accordance with the National Electrical Code and local codes. In Canada, all wiring must be installed in accordance with the Canadian Electrical Code and in accordance with the regulations of the authorities having jurisdiction. Power supply voltage must conform to the voltage shown on the unit serial plate. A wiring diagram of the unit is attached to the inside of the electrical cover. The power supply shall be sized and fused according to the specifications supplied. A ground lug is supplied in the control compartment for equipment ground.

The unit rating plate lists a Maximum Time Delay Fuse” or “HACR” type circuit breaker that is to be used with the equipment. The correct size must be used for proper circuit protection and also to assure that there will be no nuisance tripping due to the momentary high starting current of the compressor motor.

CONTROL CIRCUIT WIRING

The minimum control circuit wiring gauge needed to insure proper operation of all controls in the unit will depend on two factors.

1. The rated VA of the control circuit transformer.
2. The maximum total distance of the control circuit wiring.

Table 6 should be used to determine proper gauge of control circuit wiring required.

**TABLE 6
CONTROL CIRCUIT WIRING**

| Rated VA of Control Circuit Transformer | Transformer Secondary FLA @ 24V | Maximum Total Distance of Control Circuit Wiring in Feet |
|---|---------------------------------|--|
| 50 | 2.1 | 20 gauge - 45 18 gauge - 60 16 gauge - 100 14 gauge - 160 12 gauge - 250 |

Example: 1. Control Circuit transformer rated at 50 VA
2. Maximum total distance of control circuit wiring 85 feet.

From Table 6 minimum of 16 gauge wire should be used in the control circuit wiring.

WALL THERMOSTATS

The following wall thermostats and subbases should be used as indicated, depending on the application.

**TABLE 7
WALL THERMOSTAT**

| Thermostat | Predominant Features |
|---------------------------|--|
| 8403-049 (1F93-380) | 2 stage Cool; 2 stage Heat Programmable Electronic Auto or Manual changeover |
| 8403-058 (TH5220D1151) | 2 stage Cool; 2 stage Heat Electronic Non-Programmable Auto or Manual changeover |

THERMOSTAT INDICATORS

8403-049 (1F93-380) Thermostat:

In heating and cooling, the LED will illuminate green for first stage and yellow for second stage. The same LED will illuminate red for Emergency heating mode and will flash red if there is a malfunction in the system. The Malfunction indicator is accomplished by a relay output from the heat pump control board. A condition such as loss of charge or high head pressure that will prevent the compressor from operation will cause the flashing red light to activate. This is a signal to the operator of the equipment to place system in the emergency position.

8403-058 (TH5220D1151) Thermostat:

Thermostat will display on the screen “Em Heat” when the thermostat is set on emergency heat.

EMERGENCY HEAT MODE

The operator of the equipment must manually place the system switch in this mode. This is done when there is a known problem with the unit.

BLOWER CONTROL SETUP

Due to the unique functions that the ECM blower motor is able to perform each installation requires that the jumpers on the blower control board be checked and possibly moved based on the final installation. (See Figure 5.) Check Table 8 to verify the ADJUST, HEAT, COOL, and DELAY taps are set in the proper location for the installation.

HUMIDITY CONTROL

With the use of optional humidistat 8403-038 cut jumper on blower control board marked “cut to enable” (refer to ⑤ on Figure 5) to allow the humidistat to reduce the blower airflow in the dehumidify mode. By reducing the airflow about 15% the air coil runs colder and thus extracts more moisture. This can increase latent capacity from 5 to 13% based on the R/H conditions of the structure being conditioned. Refer to control circuit diagram for wiring of humidistat.

CFM LIGHT

The light marked CFM on the blower control board (refer to ⑥ on Figure 5) alternates between blinking 1 second per approximately 100 CFM of air delivered by the blower, and a solid light with 1 second off period between modes.

**TABLE 8
BLOWER CONTROL SETUP**

| | |
|------------------|---|
| 1. Adjust | <ul style="list-style-type: none"> Norm - Unit shipped with jumper in this position (+) - Jumper in this position increases airflow 15% (-) - Jumper in this position decreases airflow 15% Test - Not used in this application. |
| 2. Heat | <ul style="list-style-type: none"> A. - 0 kW unit shipped with jumper in this position B. - 4.5 kW heater package installed jumper in this position C. - 9 kW heater package installed jumper in this position D. - 14kW heater package installed jumper in this position |
| 3. Cool | <ul style="list-style-type: none"> A. - Unit shipped with jumper in this position B. - Jumper in this position when any heater package installed C. - Not used in this application D. - Not used in this application |
| 4. Delay | <ul style="list-style-type: none"> A. - No delay unit shipped with jumper in this position B. - 1 min. blower delay on shut down with 56% airflow C. - 2 1/2 min. short run on start with 75% airflow plus tap B delay D. - 1 min. pre-run on start with 38% airflow plus tap B and C delay |

**FIGURE 5
BLOWER CONTROL BOARD**

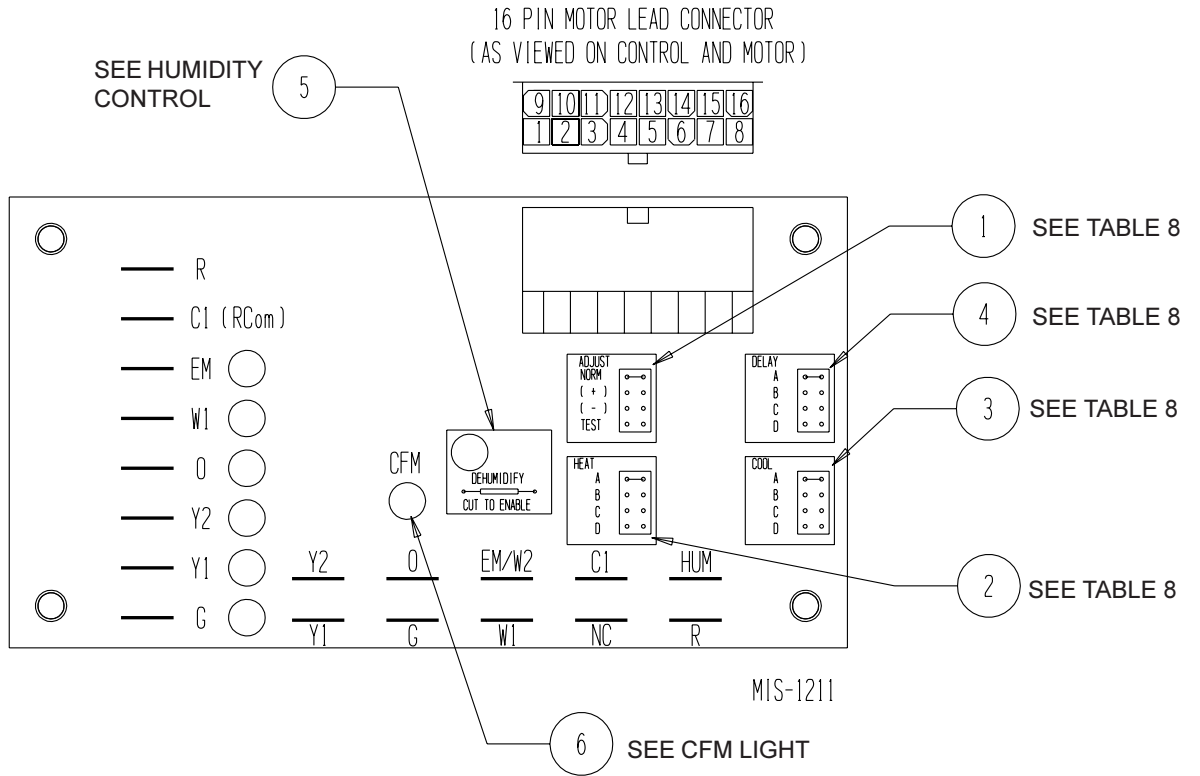

MOTOR LEAD CONNECTOR INFORMATION

| PIN | DESCRIPTION | WIRE COLOR |
|-----|-------------|------------|
| 1 | C1 | BLACK |
| 2 | W1 | BLUE |
| 3 | C2 | BLACK |
| 4 | DELAY | WHITE |
| 5 | COOL | PURPLE |
| 6 | Y1 | YELLOW |
| 7 | ADJUST | TAN |
| 8 | OUT- | BLACK |
| 9 | O | BROWN |
| 10 | BK/PWM | GREEN |
| 11 | HEAT | PURPLE |
| 12 | R | RED |
| 13 | EM/W2 | PINK |
| 14 | Y2 | YELLOW |
| 15 | G | ORANGE |
| 16 | OUT+ | BLACK |

16 PIN MOTOR LEAD CONNECTOR
(AS VIEWED FROM PIN END OF CONNECTOR LEADS)

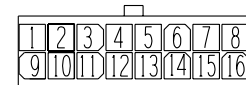

THERMOSTAT
1F93-380

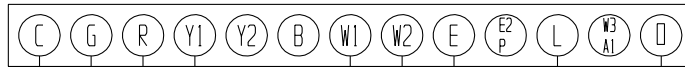

UNIT 24V
TERMINAL BLOCK



TAPE OFF THIS LEAD

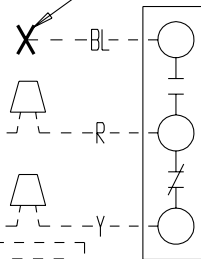

H600A 1014
HUMIDITY CONTROL
(OPTIONAL)

SOLENOID VALVE
(OPTIONAL)

- REMOVE JUMPER "W2" "W3"
- REFER TO SECTION "HUMIDITY CONTROL" FOR SET UP

| | FACTORY WIRING | FIELD WIRING |
|--------------|-------------------|-----------------|
| LOW VOLTAGE | _____ | ----- |
| HIGH VOLTAGE | ————— | ----- |

4091-505

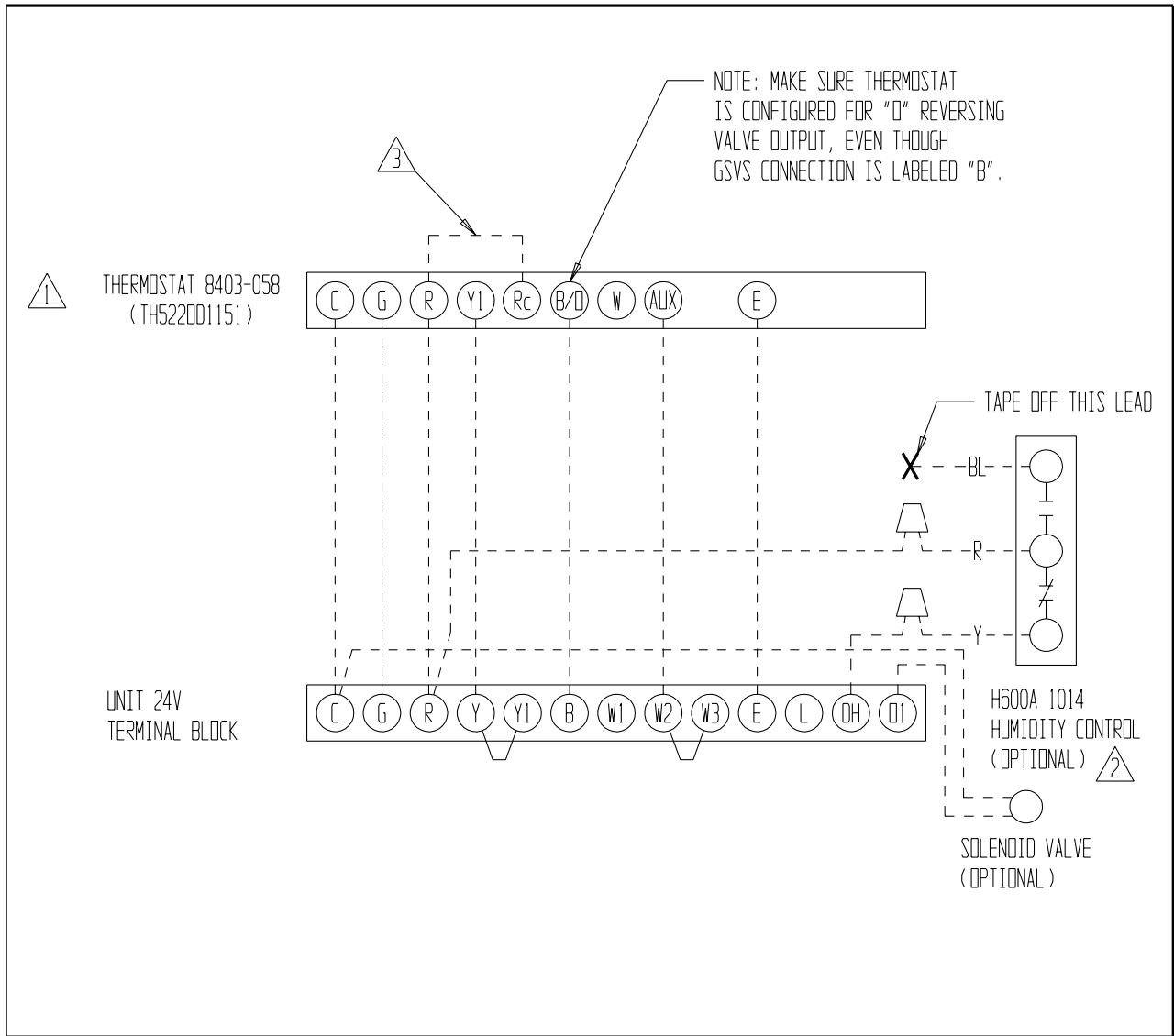

- 1 SEE THERMOSTAT INSTALLATION INSTRUCTIONS FOR SET UP
- 2 REFER TO SECTION "HUMIDITY CONTROL" FOR SET UP
- 3 FACTORY INSTALLED JUMPER

| | FACTORY WIRING | FIELD WIRING |
|--------------|----------------|--------------|
| LOW VOLTAGE | — | - - - - |
| HIGH VOLTAGE | — | - - - - |

4091-503 B

CLOSED LOOP (EARTH COUPLED GROUND LOOP APPLICATIONS)

NOTE:

Unit shipped from factory with 27 PSIG low pressure switch wired into control circuit and must be rewired to 15 PSIG low pressure switch for closed loop applications. This unit is designed to work on earth coupled ground loop systems, however, these systems operate at entering water (without antifreeze) temperature with pressures well below the pressures normally experienced in water well systems.

THE CIRCULATION SYSTEM DESIGN

Equipment room piping design is based on years of experience with earth coupled heat pump systems. The design eliminates most causes of system failure.

Surprisingly, the heat pump itself is rarely the cause. Most problems occur because designers and installers forget that a closed loop earth coupled heat pump system is NOT like a household plumbing system.

Most household water systems have more than enough water pressure either from the well pump of the

municipal water system to overcome the pressure of head loss in 1/2 inch or 3/4 inch household plumbing. A closed loop earth coupled heat pump system, however, is separated from the pressure of the household supply and relies on a small, low wattage pump to circulate the water and antifreeze solution through the earth coupling, heat pump and equipment room components.

The small circulator keeps the operating costs of the system to a minimum. However, the performance of the circulator MUST be closely matched with the pressure of head loss of the entire system in order to provide the required flow through the heat pump. Insufficient flow through the heat exchanger is one of the most common causes of system failure. Proper system piping design and circulator selection will eliminate this problem

Bard supplies a work sheet to simplify head loss calculations and circulator selection. Refer to “Circulating Pump Worksheet” section in manual 2100-099.

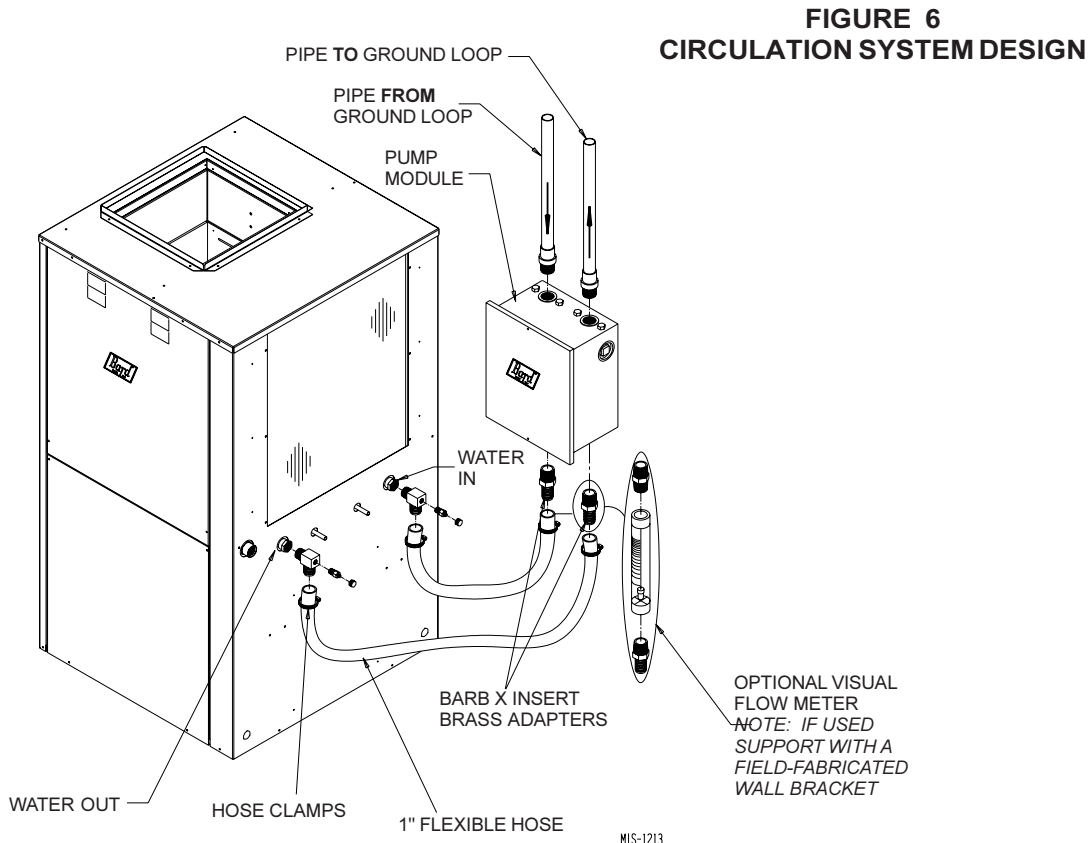

**FIGURE 6
CIRCULATION SYSTEM DESIGN**

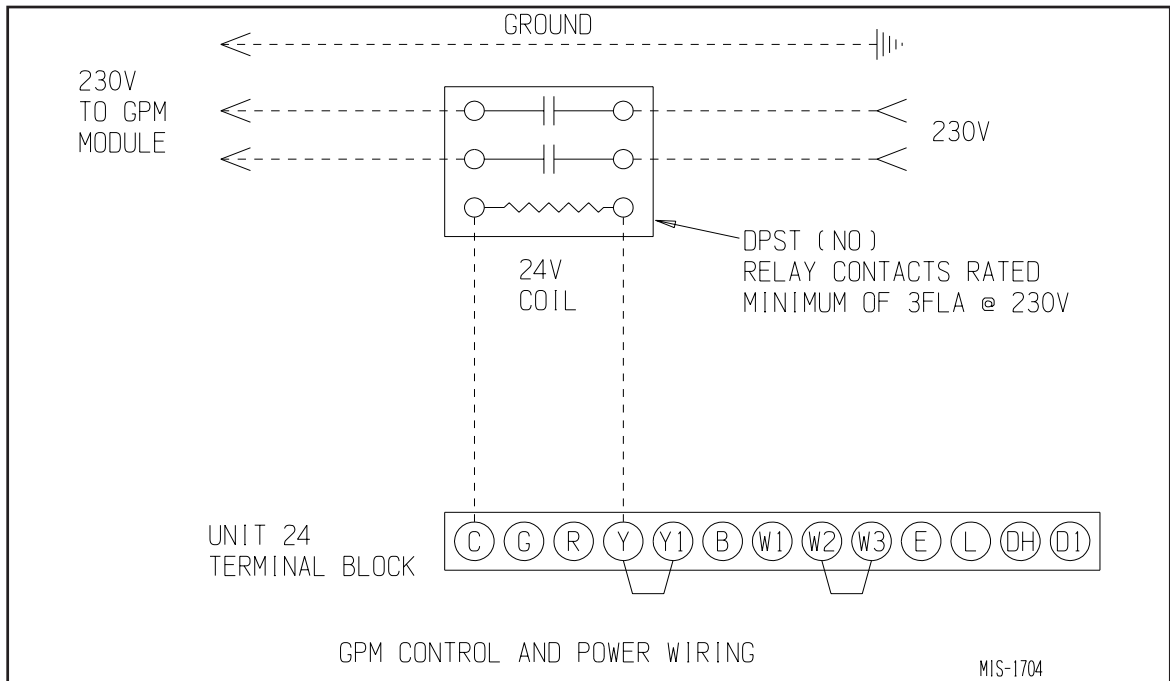

START UP PROCEDURE FOR CLOSED LOOP SYSTEM

1. Be sure main power to the unit is OFF at disconnect.
 2. Set thermostat system switch to OFF, fan switch to AUTO.
 3. Move main power disconnect to ON. Except as required for safety while servicing, *DO NOT OPEN THE UNIT DISCONNECT SWITCH.*
 4. Check system airflow for obstructions.
 - A. Move thermostat fan switch to ON. Blower runs.
 - B. Be sure all registers and grilles are open.
 - C. Move thermostat fan switch to AUTO. Blowing should stop.
 5. Flush, fill and pressurize the closed loop system as outlined in manual 2100-099.
 6. Fully open the manual inlet and outlet valves. Start the loop pump module circulator(s) and check for proper operation. If circulator(s) are not operating, turn off power and diagnose the problem.
 7. Check fluid flow using a direct reading flow meter or a single water pressure gauge, measure the pressure drop at the pressure/temperature plugs across the water coil. Compare the measurement with flow versus pressure drop table to determine the actual flow rate. If the flow rate is too low,
 8. Start the unit in cooling mode. By moving the thermostat switch to cool, fan should be set for AUTO.
 9. Check the system refrigerant pressures against the cooling refrigerant pressure table in the installation manual for rated water flow and entering water temperatures. If the refrigerant pressures do not match, check for airflow problem then refrigeration system problem.
 10. Switch the unit to the heating mode. By moving the thermostat switch to heat, fan should be set for AUTO.
 11. Check the refrigerant system pressures against the heating refrigerant pressure table in installation manual. Once again, if they do not match, check for airflow problems and then refrigeration system problems.
- NOTE:* If a charge problem is determined (high or low):
- A. Check for possible refrigerant leaks.
 - B. Recover all remaining refrigerant from unit and repair leak.
 - C. Evacuate unit down to 29 inches of vacuum
 - D. Recharge the unit with refrigerant by weight. This is the only way to insure a proper charge.

FIGURE 7

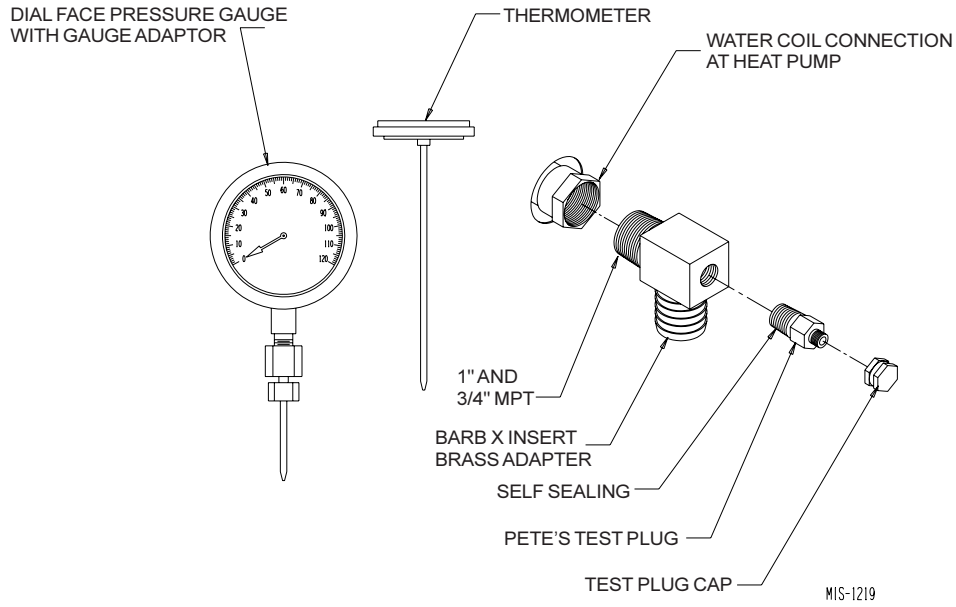

**FIGURE 8
PERFORMANCE MODEL GPM-1 LOOP PUMP MODULE**

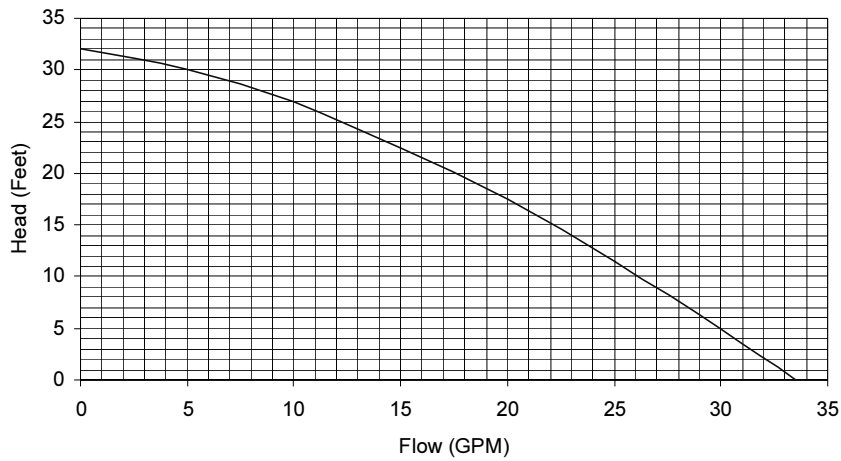

**FIGURE 9
PERFORMANCE MODEL GPM-2 LOOP PUMP MODULE**

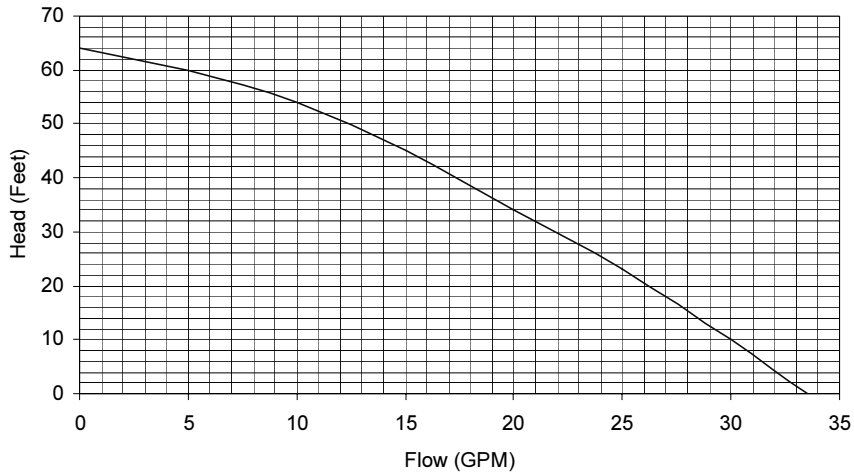

OPEN LOOP (WELL SYSTEM APPLICATIONS)

NOTE:

Unit shipped from factory with 27 PSIG low pressure switch wired into control circuit for open loop applications.

WATER CONNECTIONS

It is very important that an adequate supply of clean, noncorrosive water at the proper pressure be provided before the installation is made. Insufficient water, in the heating mode for example, will cause the low pressure switch to trip, shutting down the heat pump. In assessing the capacity of the water system, it is advisable that the complete water system be evaluated to prevent possible lack of water or water pressure at various household fixtures whenever the heat pump turns on. All plumbing to and from the unit is to be installed in accordance with local plumbing codes. The use of plastic pipe, where permissible, is recommended to prevent electrolytic corrosion of the water pipe. Because of the relatively cold temperatures encountered with well water, it is strongly recommended that the water lines connecting the unit be insulated to prevent water droplets form condensing on the pipe surface.

Refer to piping, Figure 10. Slow closing **Solenoid Valve (6)** with a 24 V coil provides on/off control of the water flow to the unit. Refer to the wiring diagram for correct hookup of the valve solenoid coil.

Constant Flow Valve (7) provides correct flow of water to the unit regardless of variations in water pressure. Observe the water flow direction indicated by the arrow on the side of the valve body. Following is a table showing which valve is to be installed with which heat pump.

**TABLE 9
CONSTANT FLOW VALVES**

| Part No. | Min. Available Pressure PSIG | Flow Rate GPM |
|----------|------------------------------|---------------|
| 8603-007 | 15 (1) | 6 |
| 8603-008 | 15 (1) | 8 |
| 8603-010 | 15 (1) | 4 |
| 8603-011 | 15 (1) | 5 |
| 8603-019 | 15 (1) | 3 |

(1) The pressure drop through the constant flow valve will vary depending on the available pressure ahead of the valve. Unless minimum of 15 psig is available **immediately** ahead of the valve, no water will flow.

Strainer (5) installed upstream of **constant flow valve (7)** to collect foreign material which would clog the flow valve orifice.

The figure shows the use of **shutoff valves (9)** and **(11)**, on the in and out water lines to permit isolation of the unit from the plumbing system should future service work require this. Globe valves should not be used as shutoff valves because of the excessive pressure drop inherent in the valve design. Instead use gate or ball valves as shutoffs, so as to minimize pressure drop.

Drain cock (8) and **(10)**, and tees have been included to permit acid cleaning the refrigerant-to-water coil should such cleaning be required. See WATER CORROSION.

Drain cock (12) provides access to the system to check water flow through the constant flow valve to insure adequate water flow through the unit. A water meter is used to check the water flow rate.

WELL PUMP SIZING

Strictly speaking, sizing the well pump is the responsibility of the well drilling contractor. It is important, however, that the HVAC contractor be familiar with the factors that determine what size pump will be required. Rule of thumb estimates will invariably lead to under or oversized well pumps. Undersizing the pump will result in inadequate water to the whole plumbing system, but with especially bad results to the heat pump – NO HEAT / NO COOL calls will result. Oversized pumps will short cycle and could cause premature pump motor or switch failures.

The well pump must be capable of supplying enough water and at an adequate pressure to meet competing demands of water fixtures. The well pump must be sized in such a way that three requirements are met:

1. Adequate flow rate in GPM.
2. Adequate pressure at the fixture.
3. Able to meet the above from the depth of the well-feet of lift.

The pressure requirements put on the pump are directly affected by the diameter of pipe being used, as well as, by the water flow rate through the pipe. The worksheet included in manual 2110-078 should guarantee that the well pump has enough capacity. It should also ensure

that the piping is not undersized, which would create too much pressure due to friction loss. High pressure losses due to undersized pipe will reduce efficiency and require larger pumps and could also create water noise problems.

FIGURE 10
WATER CONNECTION COMPONENTS

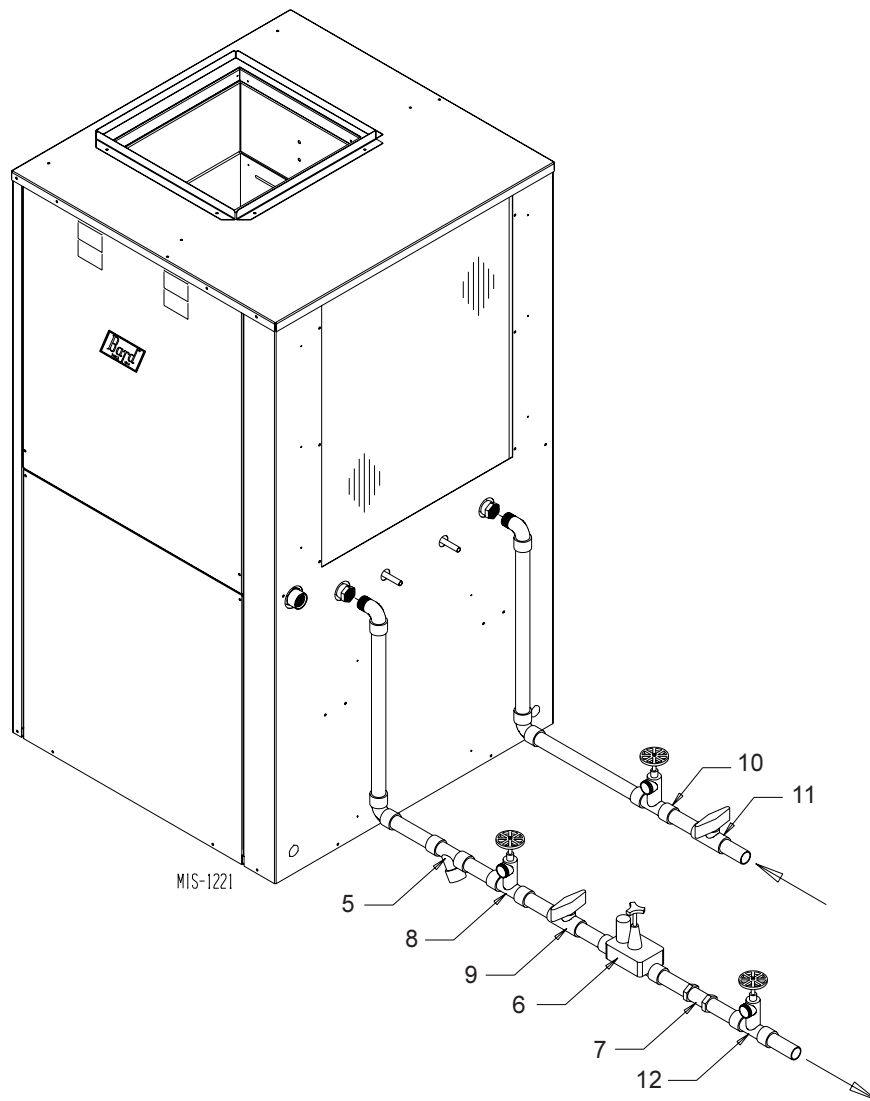

SYSTEM START UP PROCEDURE FOR OPEN LOOP APPLICATIONS

1. Be sure main power to the unit is OFF at disconnect.
2. Set thermostat system switch to OFF, fan switch to AUTO.
3. Move main power disconnect to ON. Except as required for safety while servicing – *DO NOT OPEN THE UNIT DISCONNECT SWITCH.*
4. Check system airflow for obstructions.
 - A. Move thermostat fan switch to ON. Blower runs.
 - B. Be sure all registers and grilles are open.
 - C. Move thermostat fan switch to AUTO. Blower should stop.
5. Fully open the manual inlet and outlet valves.
6. Check water flow.
 - A. Connect a water flow meter to the drain cock between the constant flow valve and the solenoid valve. Run a hose from the flow meter to a drain or sink. Open the drain cock.
 - B. Check the water flow rate through constant flow valve to be sure it is the same as the unit is rated for. (Example: 4 GPM for a GSVS302-A.)
 - C. When water flow is okay, close drain cock and remove the water flow meter. The unit is now ready to start.
7. Start the unit in cooling mode. By moving the thermostat switch to cool, fan should be set for AUTO.
 - A. Check to see the solenoid valve opened.
8. Check the system refrigerant pressures against the cooling refrigerant pressure table in the installation manual for rated water flow and entering water temperatures. If the refrigerant pressures do not match, check for airflow problem that refrigeration system problem.
9. Switch the unit to the heat mode. By moving the thermostat switch to heat, fan should be set for AUTO.
 - A. Check to see the solenoid valve opened again.
10. Check the refrigerant system pressures against the heating refrigerant pressure table in installation manual. Once again, if they do not match, check for airflow problems and then refrigeration system problems.

NOTE: If a charge problem is determined (high or low):

- A. Check for possible refrigerant loss.
- B. Discharge all remaining refrigerant from unit.
- C. Evacuate unit down to 29 inches of vacuum.
- D. Recharge the unit with refrigerant by weight. This is the only way to insure proper charge.

WATER CORROSION

Two concerns will immediately come to light when considering a water source heat pump, whether for ground water or for a closed loop application: Will there be enough water? And, how will the water quality affect the system?

Water quantity is an important consideration and one which is easily determined. The well driller must perform a pump down test on the well according to methods described by the Nation Well Water Association. This test, if performed correctly, will provide information on the rate of flow and on the capacity of the well. It is important to consider the overall capacity of the well when thinking about a water source heat pump because the heat pump may be required to run for extended periods of time.

The second concern, about water quality, is equally important. Generally speaking, if the water is not offensive for drinking purposes, it should pose no problem for the heat pump. The well driller or local water softening company can perform tests which will determine the chemical properties of the well water.

Water quality problems will show up in the heat pump in one of more of the following ways:

1. Decrease in water flow through the unit.
2. Decreased heat transfer of the water coil (entering to leaving water temperature difference is less).

There are four main water quality problems associated with ground water. These are:

1. **Biological Growth.** This is the growth of microscopic organisms in the water and will show up as a slimy deposit throughout the water system. Shock treatment of the well is usually required and this is best left up to the well driller. The treatment consists of injecting chlorine into the well casing and flushing the system until all growth is removed.
2. **Suspended Particles in the Water.** Filtering will usually remove most suspended particles (fine sand, small gravel) from the water. The problem with suspended particles in the water is that it will erode metal parts, pumps, heat transfer coils, etc. So long as the filter is cleaned and periodically maintained, suspended particles should pose no serious problem. Consult with your well driller.
3. **Corrosion of Metal.** Corrosion of metal parts results from either highly corrosive water (acid water, generally not the case with ground water) or galvanic reaction between dissimilar metals in the presence of water. By using plastic plumbing or dielectric unions, galvanic reaction is eliminated. The use of corrosion resistant materials such as the Cupronickel coil) through the water system will reduce corrosion problems significantly.

4. **Scale Formation.** Of all the water problems, the formation of scale by ground water is by far the most common. Usually this scale is due to the formation of calcium carbonate by magnesium carbonate or calcium sulfate may also be present. Carbon dioxide gas (CO₂), the carbonate of calcium and magnesium carbonate, is very soluble in water. It will remain dissolved in the water until some outside factor upsets the balance. This outside influence may be a large change in water temperature or pressure. When this happens, enough carbon dioxide gas combines with dissolved calcium or magnesium in the water and falls out of solution until a new balance is reached. The change in temperature that this heat pump produces is usually not high enough to cause the dissolved gas to fall out of solution. Likewise, if pressure drops are kept to a reasonable level, no precipitation of carbon dioxide should occur.

REMEDIES OF WATER PROBLEMS

Water Treatment. Water treatment can usually be economically justified for close loop systems. However, because of the large amounts of water involved with a ground water heat pump, water treatment is generally too expensive.

Acid Cleaning the Water Coil or Heat Pump Recovery Unit. If scaling of the coil is strongly suspected, the coil can be cleaned up with a solution of Phosphoric Acid (food grade acid). Follow the manufacturer's directions for mixing, use, etc. Refer to the "Cleaning Water Coil", Figure 11. The acid solution can be introduced into the heat pump coil through the hose bib A. Be sure the isolation valves are closed to prevent contamination of the rest of the system by the coil. The acid should be pumped from a bucket into the hose bib and returned to the bucket through the other hose bib B. Follow the manufacturer's directions

for the product used as to how long the solutions to be circulated, but it is usually circulated for a period of several hours.

LAKE AND POND INSTALLATIONS

Lakes and ponds can provide a low cost source of water for heating and cooling with a ground water heat pump. Direct usage of the water without some filtration is not recommended as algae and turbid water can foul the water to freon heat exchanger. Instead, there have been very good results using a dry well dug next to the water line or edge. Normal procedure in installing a dry well is to backhoe a 15 to 20 foot hole adjacent to the body of water (set backhoe as close to the water's edge as possible). Once excavated, a perforated plastic casing should be installed with gravel backfill placed around the casing. The gravel bed should provide adequate filtration of the water to allow good performance of the ground water heat pump.

The following is a list of recommendations to follow when installing this type of system:

- A. A lake or pond should be at least 1 acre (40,000 a square feet) in surface area for each 50,000 BTUs of ground water heat pump capacity or have 2 times the cubic feet size of the dwelling that you are trying to heat (includes basement if heated).
- B. The average water depth should be a least 4 feet and there should be an area where the water depth is at least 12 to 15 feet deep.
- C. If possible, use a submersible pump suspended in the dry well casing. Jet pumps and other types of suction pumps normally consume more electrical energy than similarly sized submersible pumps. Pipe the unit the same as a water well system.

**FIGURE 11
CLEANING WATER COIL**

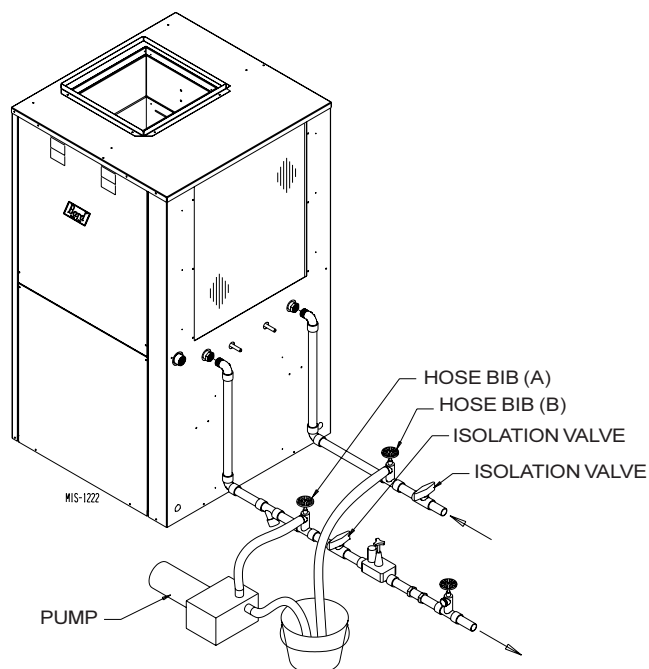

- D. Size the pump to provide necessary GPM for the ground water heat pump. A 12 GPM or greater water flow rate is required on all modes when used on this type system.
- E. A pressure tank should be installed in dwelling to be heated adjacent to the ground water heat pump. A pressure switch should be installed at the tank for pump control.
- F. All plumbing should be carefully sized to compensate for friction losses, etc., particularly if the pond or lake is over 200 feet from the dwelling to be heated or cooled.
- G. Keep all water lines below low water level and below the frost line.
- H. Most installers use 4-inch field tile (rigid plastic or corrugated) for water return to the lake or pond.
- I. The drain line discharge should be located at least 100 feet from the dry well location.
- J. The drain line should be installed with a slope of 2 inches per 10 feet of run to provide complete drainage of the line when the ground water heat pump is not operating. This gradient should also help prevent freezing of the discharge where the pipe terminates above the frost line.
- K. Locate the discharge high enough above high water level so the water will not back up and freeze inside the drain pipe.
- L. Where the local conditions prevent the use of a gravity drainage system to a lake or pond, you can instead run standard plastic piping out into the pond below the frost and low water level.



WARNING

Thin ice may result in the vicinity of the discharge line.

For complete information on water well systems and lake and pond applications, refer to Manual 2100-078 available from your distributor.

**FIGURE 12
LAKE OR POND INSTALLATION**

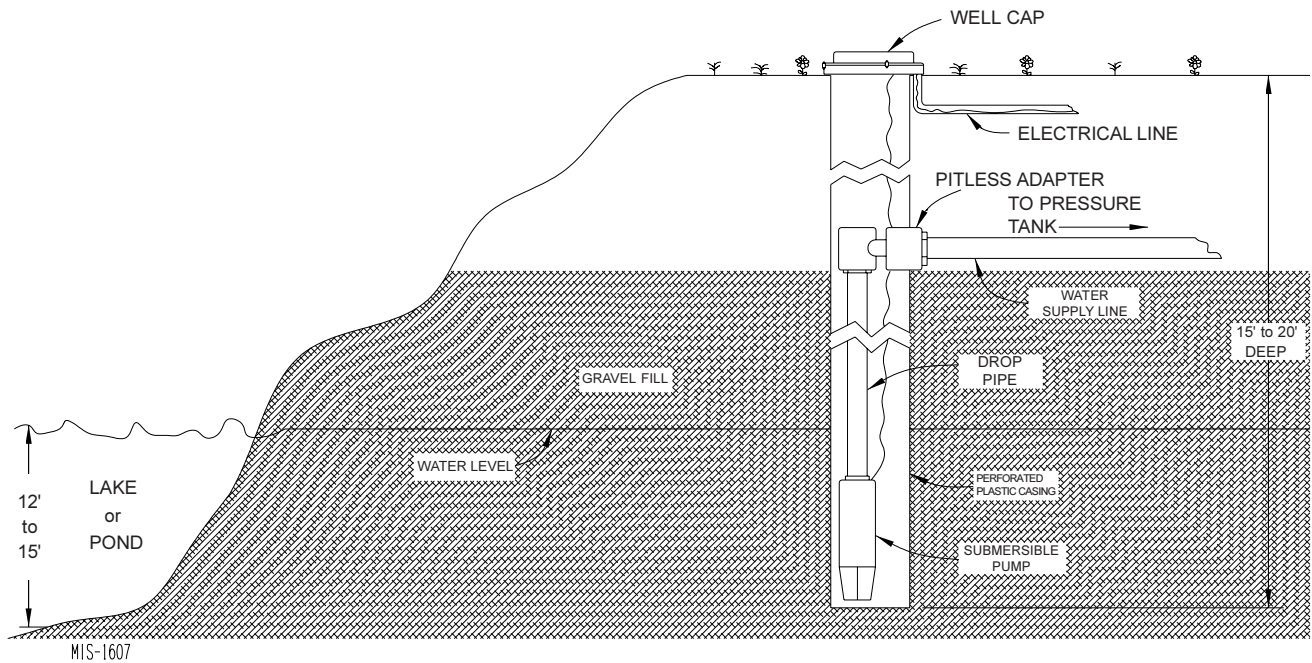

SEQUENCE OF OPERATION

BLOWER

The blower on/off actuation will depend upon “Delay” selection settings on Blower Control Board, see Blower Control Setup section. If thermostat is set to “Manual” or “On” for continuous operation the CFM will drop to 400 anytime the system is not actually heating or cooling (compressor or heaters ON). If setup for “Dehumidification Mode”, the blower will operate at reduced CFM during dehumidification cycle. During cooling, heat pump heating or electric heat operation the blower will operate at Rated CFM. (See Table 1 and also Table 8.)

COOLING

When thermostat system switch is placed in COOL it completes a circuit from “R” to “O”, energizing the reversing valve solenoid. On a call for cooling, the cooling bulb completes a circuit from “R” to “Y”, energizing the compressor contactor starting the compressor. The “R” to “G” circuit for blower operation is automatically completed on any call for cooling operation, or can be energized by manual fan switch on subbase for constant air circulation.

HEATING WITHOUT ELECTRIC HEAT

When thermostat system switch is placed in HEAT it opens the circuit from “R” to “O”, de-energizing the reversing valve solenoid. On a call for heating, it completes a circuit from “R” to “Y”, energizing the compressor contactor starting the compressor. The “R” to “G” circuit for blower operation is automatically completed on any call for heating operation, or can be energized by manual fan switch on subbase for constant air circulation.

HEATING WITH ELECTRIC HEAT

The first stage of heating is the same as heating without electric heat. When the second stage thermostat bulb makes, a circuit is completed between “R” to “W1”, energizing the heater package time delay relay(s). The electric heater elements will remain energized until the second stage bulb is satisfied at which time the circuit between “R” to “W1” will open de-energizing the heat package time delay relay(s).

EMERGENCY HEAT

When thermostat system switch is placed in EMER, the compressor circuit “R” to “Y” is locked out. Control of the electric heaters is from “R” to “W1” through the thermostat second stage heating bulb. Blower operation is controlled by an interlock circuit with the electric heater time delay relay and the blower control. The electric heater elements will remain energized until the second stage bulb is satisfied at which time the circuit

between “R” and “W1” will open de-energizing the heat package time delay relay (s) and the blower.

LOCKOUT CIRCUITS

Each unit has two separate lockout circuits, one for the high pressure switch and one for the low pressure switch. Lockout circuits operate the same in either cooling or heating operation.

High pressure lockout circuit: Consists of a normally closed switch and an impedance circuit. As long as the switch is closed, the circuit “R” to “Y” which controls the compressor contactor is complete. If the pressure rises above the set point of the switch (approximately 355 PSIG) the switch will open and the impedance circuit will lockout the circuit even after the pressure drops below the set point and switch closes. The circuit will remain in lockout until the thermostat system switch is set in the OFF position and all low voltage to the control circuit is off.

Low pressure lockout circuit: Consists of a normally open switch and a relay used in a latching circuit. As long as the switch is open, the circuit “R” to “Y” which controls the compressor contactor is complete. If the pressure drops below the set point of the switch (approximately 15 or 27 PSIG depending on switch connected) the switch will *close* and the relay will lockout the circuit even after the pressure rises above the set point and switch opens. The circuit will remain in lockout until the thermostat system switch is set in the OFF position and all low voltage to the control circuit is off.

PRESSURE SERVICE PORTS

High and low pressure service ports are installed on all units so that the system operating pressures can be observed. Pressure tables can be found later in the manual covering all models. It is imperative to match the correct pressure table to the unit by model number.

SYSTEM START-UP

- Step 1 – Close disconnect switch(es) and set the thermostat to cool and the temperature to the highest setting.
- Step 2 – Check for proper airflow across the indoor coil.
- Step 3 – Connect the service gauges and allow the unit to run for at least 10 minutes or until pressures are stable. Check pressures to the system pressure table attached to the unit service panel.
- Step 4 – Fill out Ground Source Heat Pump Performance Report.

FIGURE 13

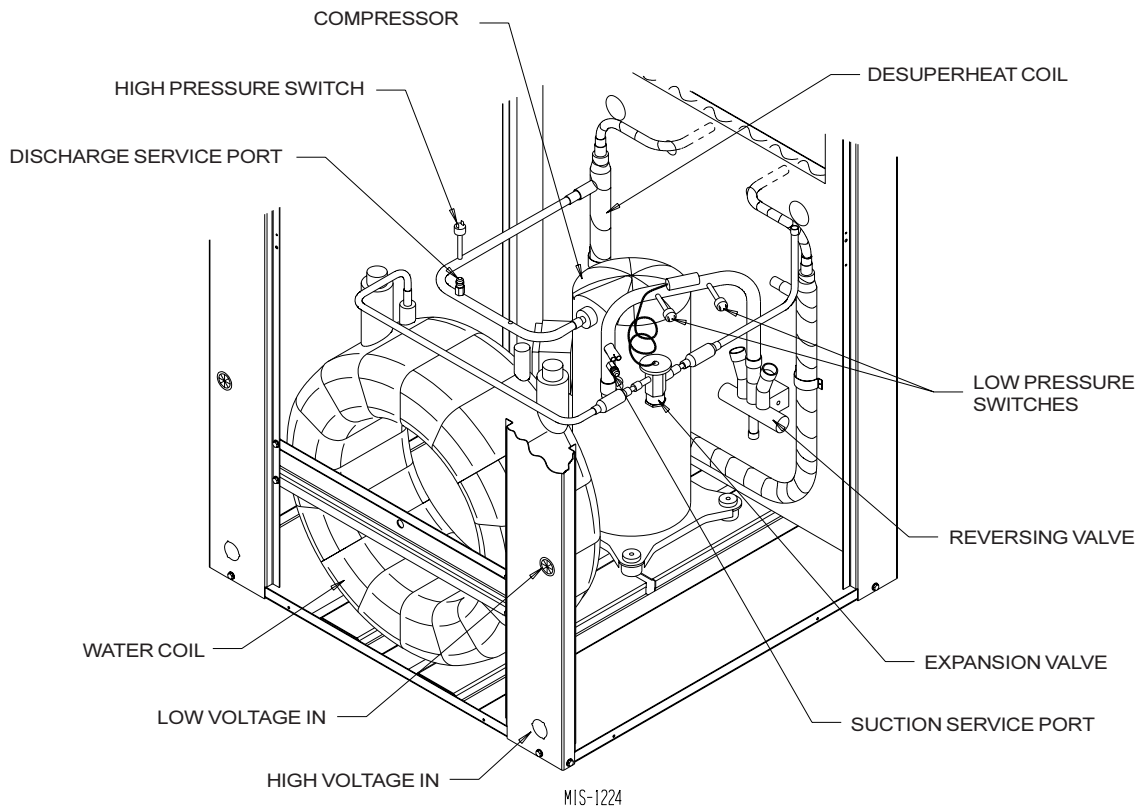

**FIGURE 14
 CONTROL PANEL**

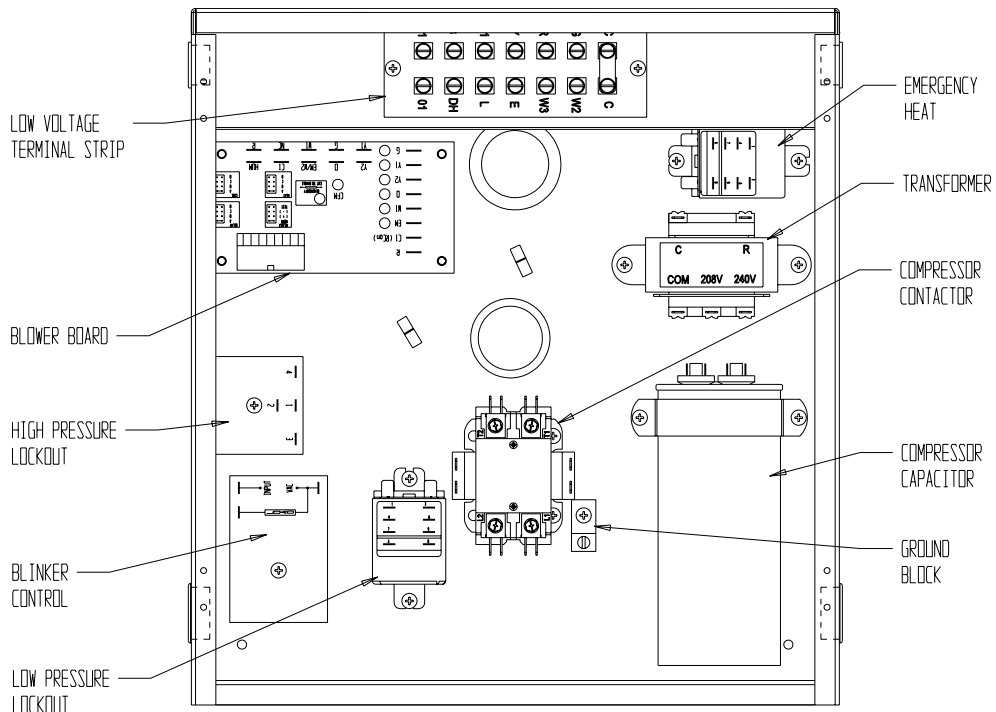

MIS-1889

FIGURE 15

COOLING CYCLE

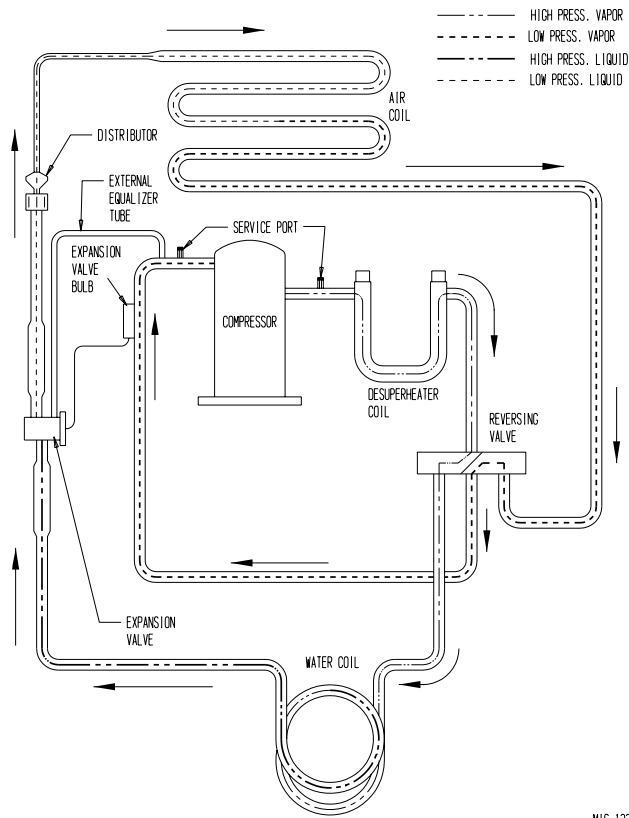

MIS-1229

HEATING CYCLE

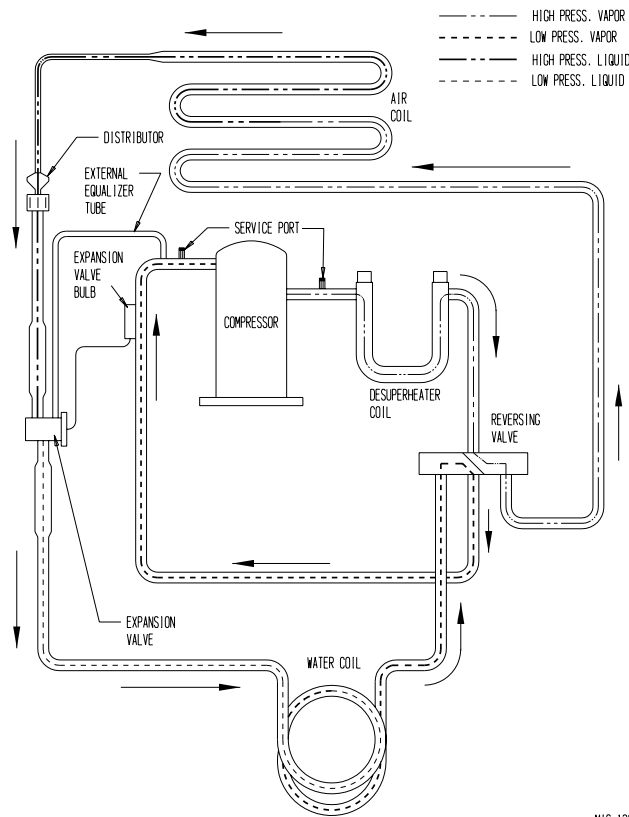

MIS-1228

**FIGURE 16
PRESSURE TABLE**

COOLING

Fluid Temperature Entering Water Coil Degree F

| Model | Return Air Temperature | Pressure | 45 | 50 | 55 | 60 | 65 | 70 | 75 | 80 | 85 | 90 | 95 | 100 | 105 | 110 |
|--------------|-------------------------------|-----------------|-----------|-----------|-----------|-----------|-----------|-----------|-----------|-----------|-----------|-----------|-----------|------------|------------|------------|
| GSVS242-A | 75 deg. DB | Low Side | 74 | 75 | 76 | 77 | 78 | 79 | 80 | 81 | 82 | 83 | 84 | 85 | 86 | 87 |
| | 62 deg. WB | High Side | 116 | 128 | 140 | 151 | 163 | 175 | 186 | 198 | 210 | 221 | 233 | 245 | 256 | 268 |
| | 80 deg. DB | Low Side | 79 | 80 | 81 | 82 | 83 | 84 | 85 | 87 | 88 | 89 | 90 | 91 | 92 | 93 |
| GSVS302-A | 67 deg. WB | High Side | 119 | 131 | 143 | 155 | 167 | 179 | 191 | 203 | 215 | 227 | 239 | 251 | 263 | 275 |
| | 85 deg. DB | Low Side | 85 | 86 | 87 | 88 | 89 | 90 | 91 | 93 | 94 | 95 | 96 | 97 | 98 | 99 |
| | 72 deg. WB | High Side | 124 | 136 | 148 | 161 | 173 | 186 | 198 | 210 | 223 | 235 | 248 | 260 | 273 | 285 |
| GSVS361-A | 75 deg. DB | Low Side | 72 | 73 | 74 | 75 | 76 | 77 | 78 | 79 | 80 | 81 | 82 | 83 | 84 | 85 |
| | 62 deg. WB | High Side | 114 | 125 | 136 | 146 | 157 | 168 | 179 | 189 | 200 | 211 | 222 | 232 | 243 | 254 |
| | 80 deg. DB | Low Side | 77 | 78 | 79 | 80 | 81 | 82 | 83 | 84 | 85 | 86 | 87 | 88 | 89 | 91 |
| GSVS421-A | 67 deg. WB | High Side | 117 | 128 | 139 | 150 | 161 | 172 | 184 | 195 | 206 | 217 | 228 | 239 | 250 | 261 |
| | 85 deg. DB | Low Side | 83 | 84 | 84 | 86 | 87 | 88 | 89 | 90 | 91 | 92 | 93 | 94 | 95 | 96 |
| | 72 deg. WB | High Side | 120 | 132 | 144 | 155 | 167 | 179 | 190 | 202 | 214 | 225 | 237 | 249 | 260 | 272 |
| GSVS361-A | 75 deg. DB | Low Side | 69 | 80 | 71 | 72 | 73 | 74 | 75 | 77 | 78 | 79 | 80 | 81 | 82 | 83 |
| | 62 deg. WB | High Side | 112 | 123 | 134 | 145 | 156 | 167 | 179 | 189 | 201 | 212 | 223 | 234 | 245 | 256 |
| | 80 deg. DB | Low Side | 74 | 75 | 76 | 77 | 78 | 79 | 80 | 81 | 82 | 83 | 84 | 85 | 86 | 87 |
| GSVS421-A | 67 deg. WB | High Side | 115 | 126 | 137 | 149 | 160 | 172 | 183 | 195 | 206 | 218 | 229 | 241 | 252 | 264 |
| | 85 deg. DB | Low Side | 80 | 81 | 82 | 83 | 84 | 85 | 86 | 87 | 88 | 89 | 90 | 91 | 92 | 93 |
| | 72 deg. WB | High Side | 118 | 130 | 142 | 154 | 166 | 178 | 190 | 202 | 214 | 226 | 238 | 250 | 262 | 274 |
| GSVS421-A | 75 deg. DB | Low Side | 69 | 70 | 71 | 72 | 73 | 74 | 75 | 76 | 77 | 78 | 79 | 80 | 81 | 82 |
| | 62 deg. WB | High Side | 126 | 137 | 148 | 159 | 170 | 181 | 193 | 204 | 215 | 226 | 237 | 248 | 259 | 270 |
| | 80 deg. DB | Low Side | 74 | 75 | 76 | 77 | 78 | 79 | 80 | 81 | 82 | 83 | 84 | 85 | 86 | 87 |
| GSVS421-A | 67 deg. WB | High Side | 129 | 140 | 151 | 163 | 174 | 186 | 197 | 209 | 220 | 232 | 243 | 255 | 266 | 278 |
| | 85 deg. DB | Low Side | 80 | 81 | 82 | 83 | 84 | 85 | 86 | 87 | 88 | 89 | 90 | 91 | 92 | 93 |
| | 72 deg. WB | High Side | 133 | 145 | 157 | 169 | 181 | 192 | 204 | 216 | 228 | 240 | 252 | 264 | 275 | 287 |

**FIGURE 16A
PRESSURE TABLE**

HEATING

Fluid Temperature Entering Water Coil Degree F

| Model | Return Air Temperature | Pressure | 45 | 50 | 55 | 60 | 65 | 70 | 75 | 80 | 85 | 90 | 95 | 100 |
|--------------|-------------------------------|-----------------|-----------|-----------|-----------|-----------|-----------|-----------|-----------|-----------|-----------|-----------|-----------|------------|
| GSVS242-A | 70 deg. DB | Low Side | 38 | 73 | 48 | 53 | 58 | 63 | 68 | 73 | 78 | 83 | 88 | 93 |
| | | High Side | 169 | 175 | 180 | 186 | 191 | 197 | 203 | 208 | 214 | 219 | 225 | 230 |
| GSVS302-A | 70 deg. DB | Low Side | 35 | 40 | 45 | 50 | 56 | 61 | 66 | 72 | 77 | 82 | 87 | 93 |
| | | High Side | 181 | 187 | 194 | 201 | 207 | 214 | 221 | 227 | 234 | 241 | 247 | 254 |
| GSVS361-A | 70 deg. DB | Low Side | 33 | 38 | 43 | 48 | 53 | 58 | 63 | 68 | 73 | 78 | 83 | 88 |
| | | High Side | 177 | 173 | 189 | 196 | 202 | 208 | 214 | 220 | 226 | 232 | 239 | 245 |
| GSVS421-A | 70 deg. DB | Low Side | 30 | 35 | 40 | 45 | 50 | 55 | 60 | 65 | 70 | 75 | 80 | 85 |
| | | High Side | 192 | 199 | 205 | 211 | 217 | 223 | 229 | 235 | 241 | 247 | 254 | 260 |

SERVICE

SERVICE HINTS

1. Caution homeowner to maintain clean air filters at all times. Also, not to needlessly close off supply and return air registers. This reduces airflow through the system, which shortens equipment service life as well as increasing operating costs.
2. Check all power fuses or circuit breakers to be sure that they are the correct rating.

UNBRAZING SYSTEM COMPONENTS

If the refrigerant charge is removed from a scroll equipped unit by bleeding the high side only, it is sometimes possible for the scrolls to seal, preventing pressure equalization through the compressor. This may leave low side shell and suction line tubing pressurized. If the brazing torch is then applied to the low side while the low side shell and suction line contains pressure, the pressurized refrigerant and oil mixture could ignite when it escapes and contacts the brazing flame. To prevent this occurrence, it is important to check both the high and low side with manifold gauges before unbrazing.

This unit is equipped with a variable speed ECM motor. The motor is designed to maintain rated airflow up to the maximum static allowed. It is important that the blower motor plugs are not plugged in or unplugged while the power is on. Failure to remove power prior to unplugging or plugging in the motor could result in motor failure.



CAUTION

Do not plug in or unplug blower motor connectors while the power is on. Failure to do so may result in motor failure.



WARNING

Both the high and low side of the scroll compressor must be checked with manifold gauges before unbrazing system components. Failure to do so could cause pressurized refrigerant and oil mixture to ignite if it escapes and contacts the brazing flame causing property damage, bodily harm or death.

TROUBLESHOOTING GE ECM™ MOTORS

CAUTION:

Disconnect power from unit before removing or replacing connectors, or servicing motor. To avoid electric shock from the motor's capacitors, disconnect power and wait at least 5 minutes before opening motor.

Symptom

Motor rocks slightly when starting

Cause/Procedure

- This is normal start-up for ECM

Motor won't start

- No movement

- Check blower turns by hand
- Check power at motor
- Check low voltage (24 Vac R to C) at motor
- Check low voltage connections (G, Y, W, R, C) at motor
- Check for unseated pins in connectors on motor harness
- Test with a temporary jumper between R - G
- Check motor for tight shaft
- Perform motor/control replacement check
- **Perform Moisture Check**

- Motor rocks, but won't start

- Check for loose or compliant motor mount
- Make sure blower wheel is tight on shaft
- Perform motor/control replacement check

Motor oscillates up & down while being tested off of blower

- It is normal for motor to oscillate with no load on shaft

Motor starts, but runs erratically

- Varies up and down or intermittent

- Check line voltage for variation or "sag"
- Check low voltage connections (G, Y, W, R, C) at motor, unseated pins in motor harness connectors
- Check "Bk" for erratic CFM command (in variable-speed applications)
- Check out system controls, Thermostat
- **Perform Moisture Check**

- "Hunts" or "puffs" at high CFM (speed)

- Does removing panel or filter reduce "puffing"?
 - Reduce restriction
 - Reduce max airflow

- Stays at low CFM despite system call for cool or heat CFM

- Check low voltage (Thermostat) wires and connections
- Verify fan is not in delay mode; wait until delay complete
- "R" missing/not connected at motor
- Perform motor/control replacement check

- Stays at high CFM

- "R" missing/not connected at motor
- Is fan in delay mode? - wait until delay time complete
- Perform motor/control replacement check

- Blower won't shut off

- Current leakage from controls into G, Y or W? Check for Triac switched thermostat or solid-state relay

Excessive noise

- Air noise

- Determine if it's air noise, cabinet, duct or motor noise; interview customer, if necessary
- High static creating high blower speed?
 - Is airflow set properly?
 - Does removing filter cause blower to slow down? Check filter
 - Use low-pressure drop filter
 - Check/correct duct restrictions

Symptom

- Noisy blower or cabinet

Cause/Procedure

- Check for loose blower housing, panels, etc.
- High static creating high blower speed?
 - Check for air whistling through seams in ducts, cabinets or panels
 - Check for cabinet/duct deformation

- "Hunts" or "puffs" at high CFM (speed)

- Does removing panel or filter reduce "puffing"?
 - Reduce restriction
 - Reduce max. airflow

Evidence of Moisture

- Motor failure or malfunction has occurred and moisture is present
- Evidence of moisture present inside air mover

- Replace motor and **Perform Moisture Check**

- **Perform Moisture Check**

Do

- Check out motor, controls, wiring and connections thoroughly before replacing motor
- Orient connectors down so water can't get in
 - Install "drip loops"
- Use authorized motor and model #'s for replacement
- Keep static pressure to a minimum:
 - Recommend high efficiency, low static filters
 - Recommend keeping filters clean.
 - Design ductwork for min. static, max. comfort
 - Look for and recommend ductwork improvement, where necessary

Don't

- Automatically assume the motor is bad.
- Locate connectors above 7 and 4 o'clock positions
- Replace one motor or control model # with another (unless an authorized replacement)
- Use high pressure drop filters some have ½" H2O drop!
- Use restricted returns
- Oversize system, then compensate with low airflow
- Plug in power connector backwards
- Force plugs

- Size the equipment wisely

- Check orientation before inserting motor connectors

Moisture Check

- Connectors are oriented "down" (or as recommended by equipment manufacturer)
- Arrange harness with "drip loop" under motor
- Is condensate drain plugged?
- Check for low airflow (too much latent capacity)
- Check for undercharged condition
- Check and plug leaks in return ducts, cabinet

Comfort Check

- Check proper airflow settings
- Low static pressure for lowest noise
- Set low continuous-fan CFM
- Use humidistat and 2-speed cooling units
- Use zoning controls designed for ECM that regulate CFM
- Thermostat in bad location?

TROUBLESHOOTING GE ECM™ MOTORS CONT'D.

Replacing ECM Control Module

To replace the control module for the GE variable-speed indoor blower motor you need to take the following steps:

1. You **MUST** have the correct replacement module. The controls are factory programmed for specific operating modes. Even though they look alike, different modules may have completely different functionality.

USING THE WRONG CONTROL MODULE VOIDS ALL PRODUCT WARRANTIES AND MAY PRODUCE UNEXPECTED RESULTS.

2. Begin by removing AC power from the furnace or air handler being serviced. **DO NOT WORK ON THE MOTOR WITH AC POWER APPLIED.** To avoid electric shock from the motor's capacitors, disconnect power and wait at least 5 minutes before opening motor.

3. It is usually not necessary to remove the motor from the blower assembly. However, it is recommended that the whole blower assembly, with the motor, be removed from the furnace/air handler. (Follow the manufacturer's procedures). Unplug the two cable connectors to the motor. There are latches on each connector. **DO NOT PULL ON THE WIRES.** The plugs remove easily when properly released.

4. Locate the two standard 1/4" hex head bolts at the rear of the control housing (at the back end of the control opposite the shaft end). Refer to *Figure 17*. Remove these two bolts from the motor and control assembly while holding the motor in a way that will prevent the motor or control from falling when the bolts are removed. If an ECM2.0 control is being replaced (recognized by an aluminum casting rather than a deep-drawn black steel case housing the electronics), remove only the hex-head bolts. **DO NOT REMOVE THE TORX-HEAD SCREWS.**

5. The control module is now free of mechanical attachment to the motor endshield but is still connected by a plug and three wires inside the control. Carefully rotate the control to gain access to the plug at the control end of the wires. With thumb and forefinger, reach the latch holding the plug to the control and release it by squeezing the latch tab and the opposite side of the connector plug and gently pulling the plug out of the connector socket in the control. **DO NOT PULL ON THE WIRES. GRIP THE PLUG ONLY.**

6. The control module is now completely detached from the motor. Verify with a standard ohmmeter that the resistance from each motor lead (in the motor plug just removed) to the motor shell is >100K ohms. Refer to *Figure 18*. (Measure to unpainted motor end plate.) If any motor lead fails this test, do not proceed to install the control module. **THE MOTOR IS DEFECTIVE AND MUST BE REPLACED.** Installing the new control module will cause it to fail also.

7. Verify that the replacement control is correct for your application. Refer to the manufacturer's authorized replacement list. **USING THE WRONG CONTROL WILL RESULT IN IMPROPER OR NO BLOWER OPERATION.** Orient the control module so that the 3-wire motor plug can be inserted into the socket in the control. Carefully insert the plug and press it into the socket until it latches. **A SLIGHT CLICK WILL BE HEARD WHEN PROPERLY INSERTED.** Finish installing the replacement control per one of the three following paragraphs, 8a, 8b or 8c.

8a. **IF REPLACING AN ECM 2.0 CONTROL** (control in cast aluminum can with air vents on the back of the can) **WITH AN ECM 2.3 CONTROL** (control containing black potting for water protection in black deep-drawn steel case with no vents in the bottom of the can), locate the two through-bolts and plastic tab that are packed with the replacement control. Insert the plastic tab into the slot at the perimeter of the open end of the can so that the pin is located on the inside of the perimeter of the can. Rotate the can so that the tab inserts into the tab locator hole in the endshield of the motor. Using the two through-bolts provided with the replacement control, reattach the can to the motor.

THE TWO THROUGH-BOLTS PROVIDED WITH THE REPLACEMENT ECM 2.3 CONTROL ARE SHORTER THAN THE BOLTS ORIGINALLY REMOVED FROM THE ECM 2.0 CONTROL AND MUST BE USED IF SECURE ATTACHMENT OF THE CONTROL TO THE MOTOR IS TO BE ACHIEVED. DO NOT OVERTIGHTEN THE BOLTS.

8b. **IF REPLACING AN ECM 2.3 CONTROL WITH AN ECM 2.3 CONTROL**, the plastic tab and shorter through-bolts are not needed. The control can be oriented in two positions 180° apart. **MAKE SURE THE ORIENTATION YOU SELECT FOR REPLACING THE CONTROL ASSURES THE CONTROL'S CABLE CONNECTORS WILL BE LOCATED DOWNWARD IN THE APPLICATION SO THAT WATER CANNOT RUN DOWN THE CABLES AND INTO THE CONTROL.** Simply orient the new control to the motor's endshield, insert bolts, and tighten. **DO NOT OVERTIGHTEN THE BOLTS.**

8c. **IF REPLACING AN ECM 2.0 CONTROL WITH AN ECM 2.0 CONTROL** (It is recommended that ECM 2.3 controls be used for all replacements), the new control must be attached to the motor using through bolts identical to those removed with the original control. **DO NOT OVERTIGHTEN THE BOLTS.**

9. Reinstall the blower/motor assembly into the HVAC equipment. Follow the manufacturer's suggested procedures.

10. Plug the 16-pin control plug into the motor. The plug is keyed. Make sure the connector is properly seated and latched.

11. Plug the 5-pin power connector into the motor. Even though the plug is keyed, **OBSERVE THE PROPER ORIENTATION. DO NOT FORCE THE CONNECTOR.** It plugs in very easily when properly oriented. **REVERSING THIS PLUG WILL CAUSE IMMEDIATE FAILURE OF THE CONTROL MODULE.**

12. Final installation check. Make sure the motor is installed as follows:
- Unit is as far INTO the blower housing as possible.
 - Belly bands are not on the control module or covering vent holes.
 - Motor connectors should be oriented between the 4 o'clock and 8 o'clock positions when the blower is positioned in its final location and orientation.
 - Add a drip loop to the cables so that water cannot enter the motor by draining down the cables. Refer to *Figure 19*.

The installation is now complete. Reapply the AC power to the HVAC equipment and verify that the new motor control module is working properly. Follow the manufacturer's procedures for disposition of the old control module.

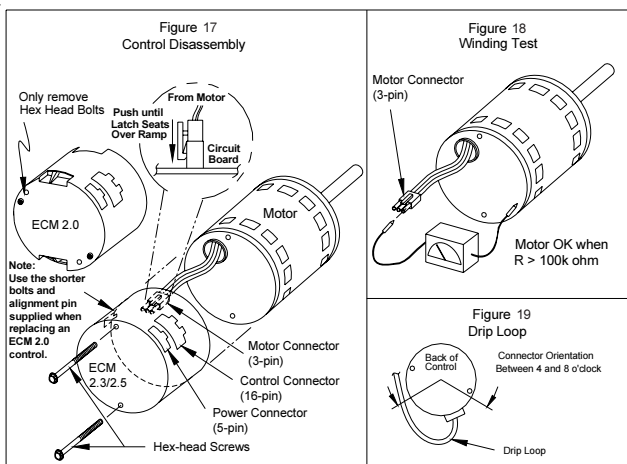

ADD-ON DPM26A PUMP MODULE KIT

NOTE: This section applies only if a DPM26A Pump Module is added. Refer to DPM26A instructions for complete installation details.

GENERAL

This high efficiency water source heat pump series was designed with a refrigerant to water heat exchanger commonly known as a desuperheater coil factory-installed for ease in installing optional DPMA pump module kit. The addition of this optional kit allows for heat recovery for hot water heating when connected to a home water heater. The amount of annual hot water supplied and thus additional energy cost savings will depend on the amount of hot water usage and the number of hours the heat pump operates. This pump kit is suitable for potable water.

INSTALLATION

1. Follow all local, state, and national codes applicable to the installation of the pump module kit.
2. Follow the installation instructions received with the DPM26A pump module kit.
3. Connect the water lines between the unit, pump module kit, and the water heater.

FIGURE 20
TYPICAL PUMP KIT CONNECTION TO UNIT
GSVS MODEL

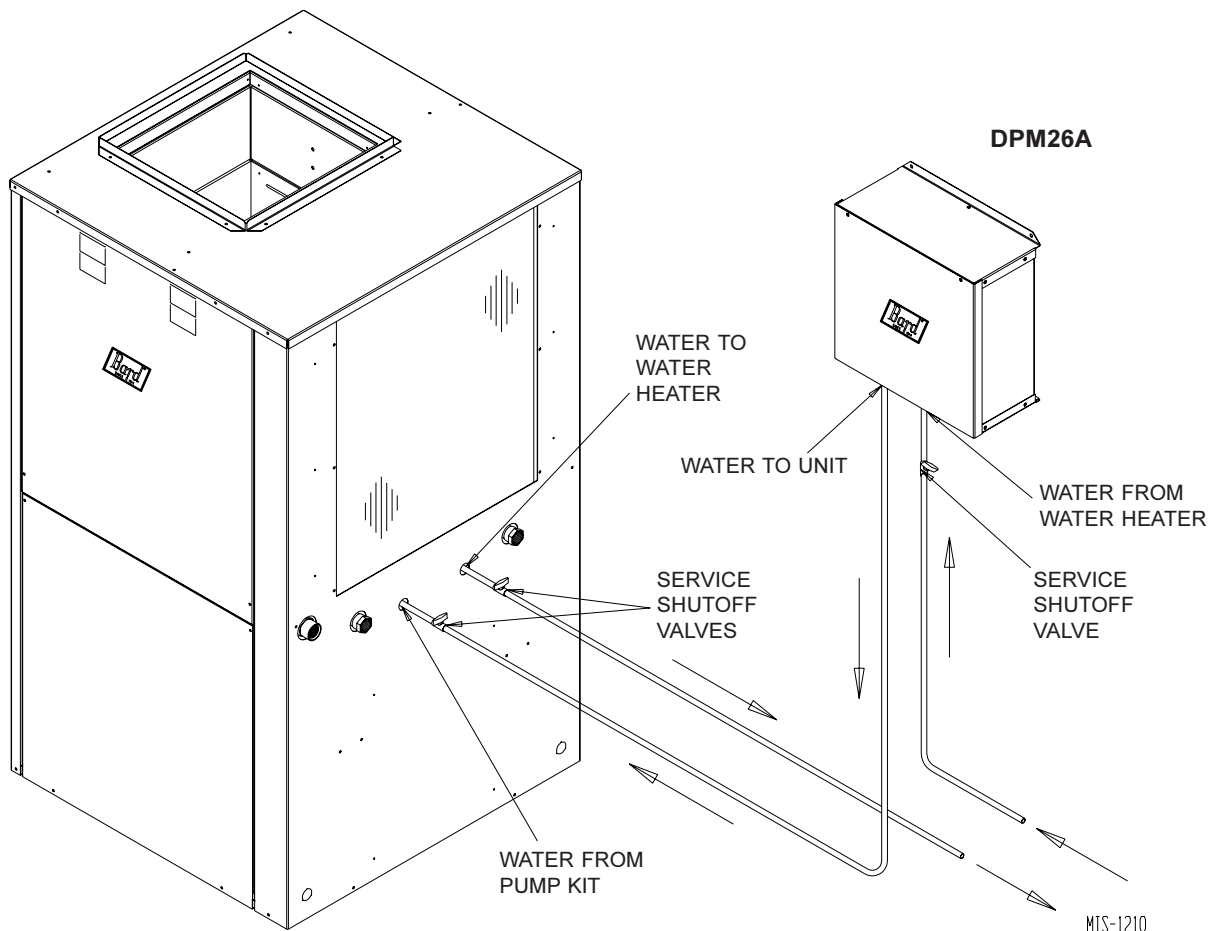

GROUND SOURCE HEAT PUMP PERFORMANCE REPORT

This performance check report should be filled out by installer and retained with unit.

DATE _____ TAKEN BY: _____

1. UNIT:
Mfgr _____ Model No. _____ S/N _____

THERMOSTAT:
Mfgr _____ Model No. _____ P/N _____

2. Person Reporting _____

3. Company Reporting _____

4. Installed By _____ Date Installed _____

5. User's (Owner's) Name _____
Address _____

6. Unit Location _____

WATER SYSTEM INFORMATION

7. Open Loop System (Water Well) _____ Closed Loop System _____

A. If Open Loop where is water discharged? _____

8. The following questions are for **Closed Loop systems only**

A. Closed loop system designed by _____

B. Type of antifreeze used _____ % Solution _____

C. System type: Series _____ Parallel _____

D. Pipe material _____ Nominal Size _____

E. Pipe Installed:

1. Horizontal _____ Total length of pipe _____ ft

No. pipes in trench _____ Depth bottom pipe _____ ft

2. Vertical _____ Total length of bore hole _____ ft

THE FOLLOWING INFORMATION IS NEEDED TO CHECK PERFORMANCE OF UNIT.

| | Cooling | ** Heating | |
|--|---------|------------|------|
| FLUID SIDE DATA | | | |
| 9. Entering fluid temperature | _____ | _____ | F |
| 10. Leaving fluid temperature | _____ | _____ | F |
| 11. Entering fluid pressure | _____ | _____ | PSIG |
| 12. Leaving fluid pressure | _____ | _____ | PSIG |
| 13. Pressure drop through coil | _____ | _____ | PSIG |
| 14. Gallons per minute through the water coil | _____ | _____ | GPM |
| 15. Liquid or discharge line pressure | _____ | _____ | PSIG |
| 16. Suction line pressure | _____ | _____ | PSIG |
| 17. Voltage at compressor (unit running) | _____ | _____ | V |
| 18. Amperage draw at line side of contactor | _____ | _____ | A |
| 19. Amperage at compressor common terminal | _____ | _____ | A |
| 20. * Suction line temperature 6" from compressor | _____ | _____ | F |
| 21. * Superheat at compressor | _____ | _____ | F |
| 22. * Liquid line temperature at metering device | _____ | _____ | F |
| 23. * Coil subcooling | _____ | _____ | F |
| INDOOR SIDE DATA | | | |
| 24. Dry bulb temperature at air entering indoor coil | _____ | _____ | F |
| 25. Wet bulb temperature of air entering indoor coil | _____ | _____ | F |
| 26. Dry bulb temperature of air leaving indoor coil | _____ | _____ | F |
| 27. Wet bulb temperature of air leaving indoor coil | _____ | _____ | F |
| 28. * Supply air static pressure (packaged unit) | _____ | _____ | WC |
| 29. * Return air static pressure (packaged unit) | _____ | _____ | WC |
| 30. Other information about installation | | | |
| | | | |
| | | | |
| | | | |
| | | | |
| | | | |
| | | | |
| | | | |

** When performing a heating test insure that 2nd stage heat is not activated
 * Items that are optional

