

QTEC Wall Sleeve

INSTALLATION INSTRUCTIONS

Models: **QWS48A**
QWS48A-16
QWS48A-19
QWS48A-23

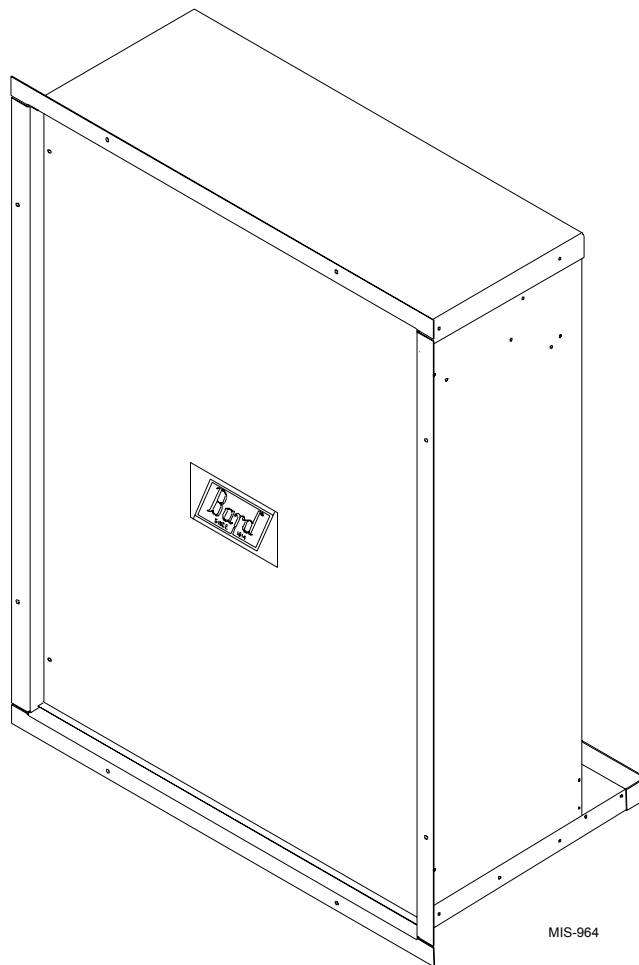

CLIMATE CONTROL SOLUTIONS

Bard Manufacturing Company
Bryan, Ohio 43506

*Since 1914 . . . Moving ahead just as
planned.*

Manual No.: 2100-319D
Supersedes: 2110-319C
File: Vol. II Tab 14
Date: 09-16-04

CONTENTS

Getting Other Information and Publications	1
QTEC Wall Sleeve General Information	
Shipping Damage	2
General	2
Installation Instructions	
Installation Wood Framed Walls	2 & 4
Installation Masonry Construction Walls	4 & 5
Accessory Item – QCDS48	
Condensate Disposal System	7
Attachment of Wall Sleeve to QTEC Unit	8

Figures		
Figure 1	Wood Framed Installation	2
Figure 2	Applicaton of Sealant to 2 x 6 Plate	3
Figure 3	Application of Sealant to Flanges	3
Figure 4	Masonry Construction Installation	4
Figure 5	Typical Installation With 14" Maximum Wall Thickness	5
Figure 6	Condenser Fill Plate Application	6
Figure 7	QCDS48 Condensate Disposal System	7
Figure 8	Attaching Base Assembly to Sleeve Showing Caulking	8

Getting Other Information and Publications

These publications can help you install the air conditioner or heat pump. You can usually find these at your local library or purchase them directly from the publisher. Be sure to consult current edition of each standard.

Standard for the Installation ofANSI/NFPA 90A
Air Conditioning and
Ventilating Systems

Standard for Warm Air Heating ANSI/NFPA 90B
Air Conditioning Systems

QTEC Installation Instruction Manual Bard/2100-288

FOR MORE INFORMATION, CONTACT THESE PUBLISHERS:

ACCA **Air Conditioning Contractors of America**
1712 New Hampshire Avenue, NW
Washington, DC 20009
Telephone: (202) 483-9370
Fax: (202) 234-4721

ANSI **American National Standards Institute**
11 West Street, 13th Floor
New York, NY 10036
Telephone: (212) 642-4900
Fax: (212) 302-1286

ASHRAE **American Society of Heating Refrigerating,
& Air Conditioning Engineers, Inc.**
1791 Tullie Circle, N.E.
Atlanta, GA 30329-2305
Telephone: (404) 636-8400
Fax: (404) 321-5478

BARD **Bard Manufacturing Company**
1914 Randolph Drive
Bryan, OH 43506
Telephone: (419) 636-1194
Fax: (419) 636-2640

SHIPPING DAMAGE

Upon receipt of equipment, the carton should be checked for external signs of shipping damage. If damage is found, the receiving party must contact the last carrier immediately, preferably in writing requesting inspection by the carrier's agent.

GENERAL

The QWS48A series is designed for use with the QTEC Series Air Conditioners and Air Source Heat Pumps. The QWS48A is for use with wall thickness of 5 to 14 inches. One QWS48A series wall sleeve is required for each QTEC Model to be installed.

The equipment covered in this manual is to be installed by trained service and installation technicians.

These instructions explain the recommended method to install the wall sleeve.

These instructions and any instructions packaged with any separate equipment required to make the entire air conditioning system should be carefully read before beginning the installation.

While these instructions are intended as a general recommended guide, they do not supersede any national and/or local codes in any way. Authorities having jurisdiction should be consulted before the installation is made.

INSTALLATION – WOOD FRAMED WALLS

For wood frame construction walls, the dimensions of the opening must be 48 inches tall by 43 inches wide. A 2 x 6 header will be required for the opening. The sides of the opening must have trimmer studs to support the header, and to provide a structural member on which to fasten the sleeve. (See Figure 1.) All of the dimensions are referenced from the finished floor height.

After the opening is framed in, a treated 2 x 6 bottom support and seal plate must be cut to fit in the bottom of the opening. Construction adhesive should be applied to the 2 x 6 before it is put in place. (See Figure 2.) This will help hold the plate in place and provide an additional seal for the bottom of the opening. The treated 2 x 6 must be fastened to the bottom of the opening flush to the finished surface of the outside wall. The 2 x 6 must be sealed to the outside wall with construction adhesive. Any gaps between the sides of the 2 x 6 plate and the opening must also be sealed. See Figure 2. *NOTE: The actual thickness of 2 x 6 must be 1-1/2".*

Once the opening is framed, the sheathing can be installed, the sheathing material must not extend into the opening.

The sleeve should be test fit into the opening to make sure of the dimensions. The sleeve must be inserted into the opening from the outside of the building. The bottom of the sleeve must be level from side to side, and the sleeve must be square in the opening. A slope is built into the bottom of the sleeve from the inside to the outside. This will allow any water that gets into the sleeve to drain out. Once the test fit is completed, the sleeve must be removed from the opening, and two 1/4 inch beads of sealant must be applied to the mounting flanges of the sleeve. (See Figure 3.)

**FIGURE 1
WOOD FRAMED INSTALLATION**

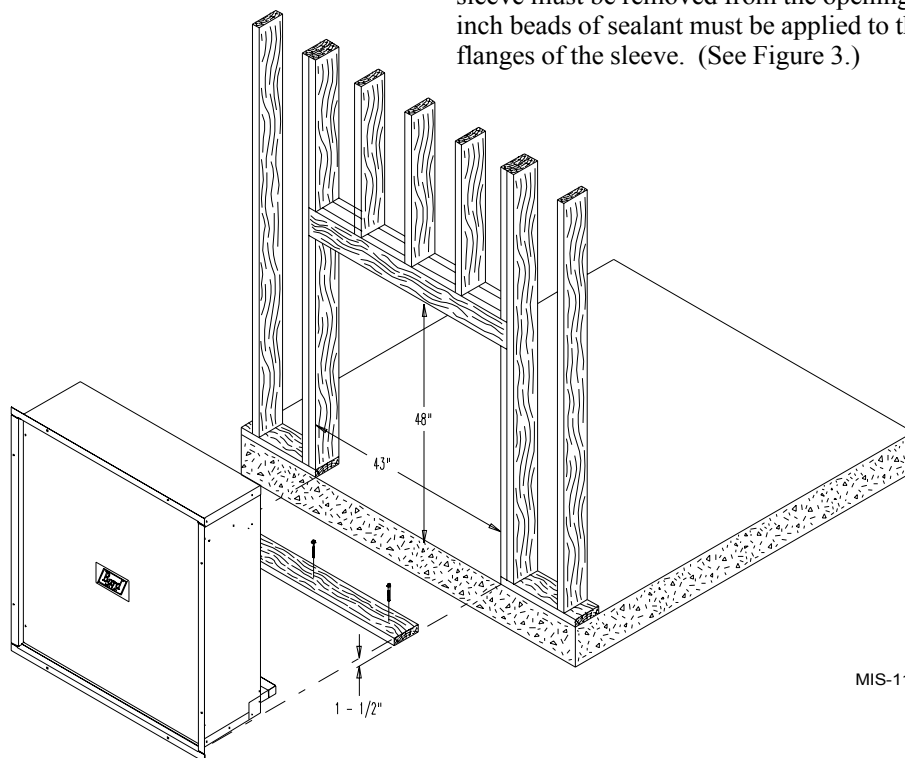

MIS-1164

FIGURE 2
APPLICATION OF SEALANT TO 2 X 6 PLATE

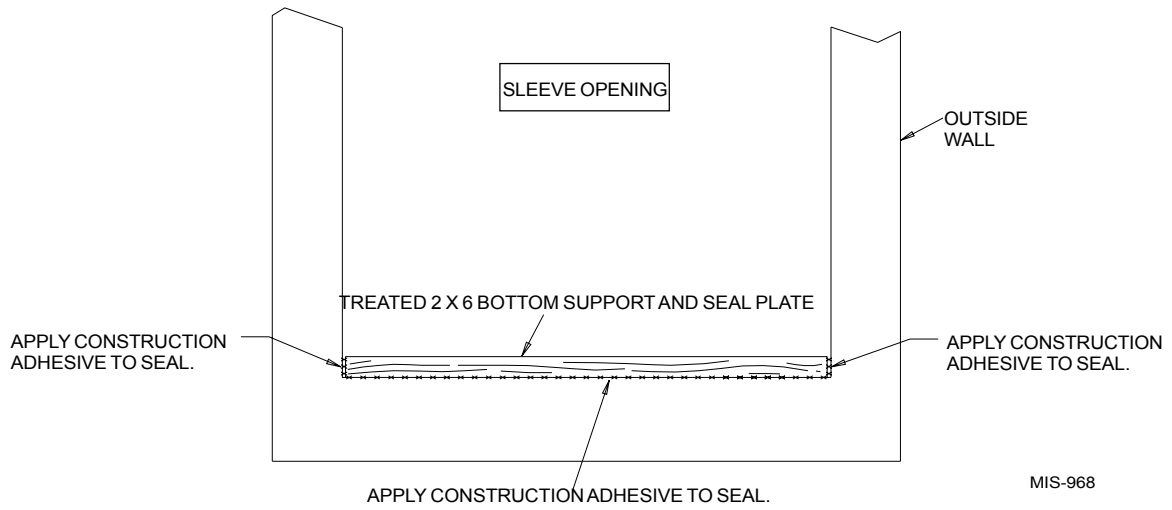

FRONT VIEW

FIGURE 3
APPLICATION OF SEALANT TO FLANGES

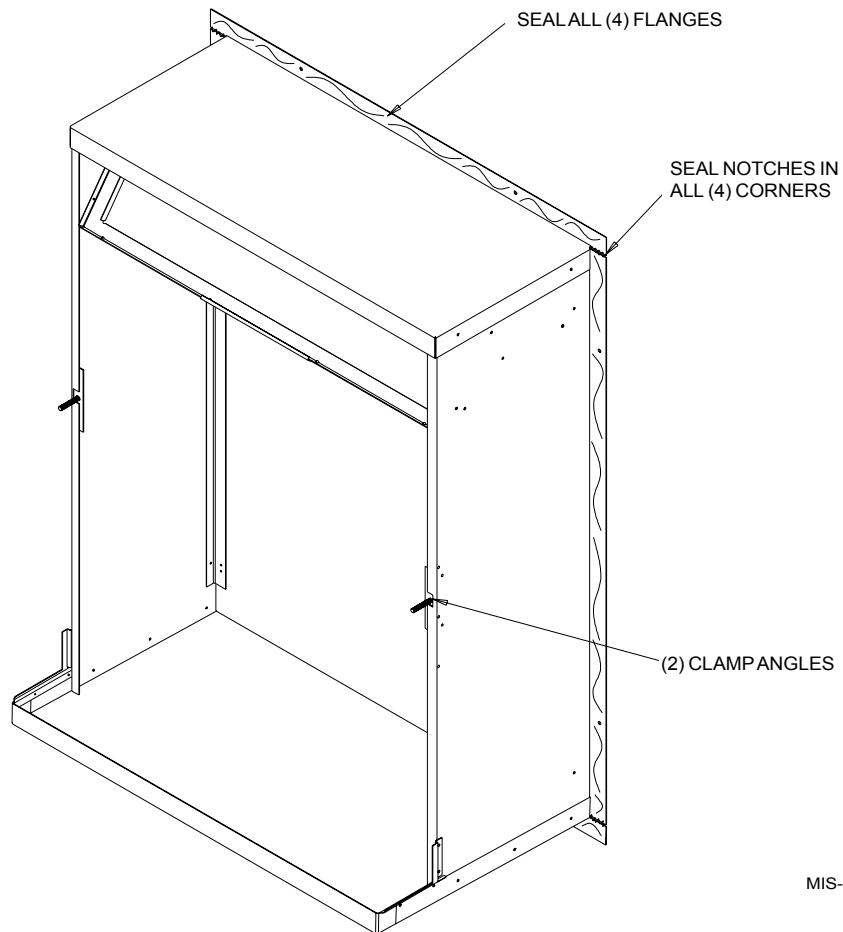

MIS-959

The sleeve is then reinserted into the prepared opening from the outside of the building. All of the mounting flanges must contact the exterior wall. Check to see that there is enough sealant to make this joint watertight. Additional sealant must be applied as necessary. The sleeve must be centered in the opening, and the bottom of the sleeve must be checked to make certain that it is level from side to side. The bottom flange should be secured to the wall by using two screws through the holes in the bottom mounting flange of the sleeve. The sleeve must be checked to make sure that it is square in the opening. Once the sleeve is square, the side and top mounting flanges of the sleeve must be secured to the wall with screws through the holes in the flanges. The gaps between the side flanges, and the top and bottom flanges must be filled with additional sealant.

On the inside of the building, the gaps between the sleeve and the opening must be filled with insulation. This will help insulate the sleeve and prevent any unwanted outdoor air. See Figure 5.

If the QTEC unit will be drained through the wall, the drain line must be installed through the wall. Information for the drain installation is contained in the QTEC Installation Instructions.

INSTALLATION – MASONRY CONSTRUCTION WALLS

For masonry construction walls, the dimensions for the opening will be 48-1/4 inches tall by 43-1/4 inches wide. These dimensions are plus or minus 1/4 inch and are measured from the finished floor height. See Figure 4. These will be the finish dimensions of the opening.

A 1-1/2 inch spacer needs to be installed in the bottom of the opening to raise the sleeve off the floor. Masonry blocks 1 inch thick, minimum of 6 inches wide, with 1/2 inch mortar between the block and floor will provide the required spacing. These blocks are to be laid flush with the outside wall, and must provide a water tight seal to the floor and to the opening sides. See Figure 2.

The sleeve should be test fit in the opening before final preparations are made. The sleeve will be installed into the opening from the outside of the building in. The sleeve must be centered in the opening from side to side. The mounting flanges of the sleeve must contact the outside wall all around the opening. The side and top mounting flanges must have the mounting holes drilled into the outside wall for the concrete anchors which will hold the sleeve in the wall. The holes should

FIGURE 4
MASONRY CONSTRUCTION INSTALLATION

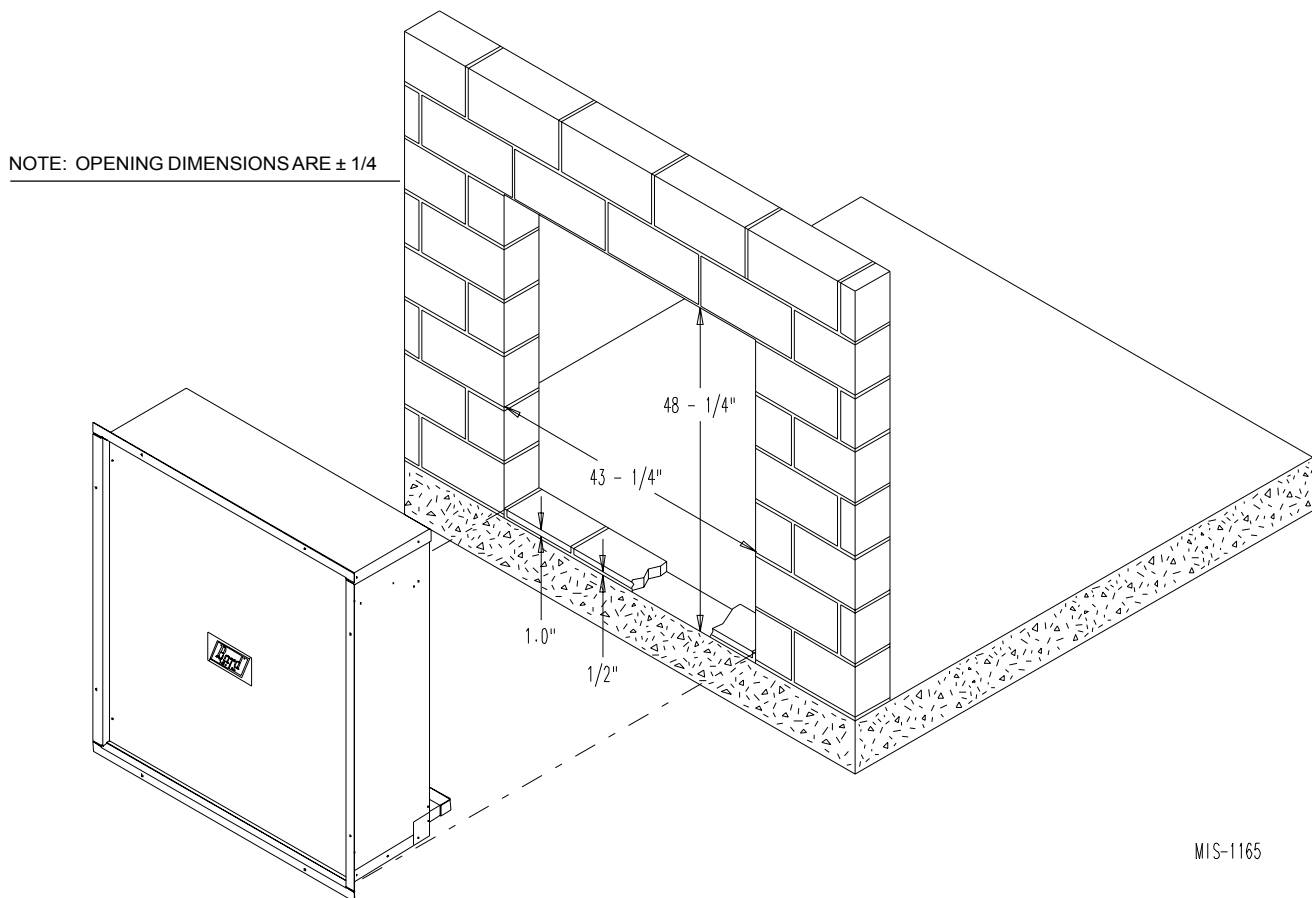

MIS-1165

be drilled through the holes in the sleeve with the sleeve level and square in the opening. A slope is built into the bottom of the sleeve from the inside to the outside. This will allow any water that gets into the sleeve to drain out. Once the test fitting has been checked out, the sleeve should be removed from the wall.

With the sleeve removed, two 1/4 inch beads of sealant must be applied to the flanges that contact the outside wall. See Figure 3

The sleeve must be installed back in the wall making sure that the predrilled holes in the wall line up with the holes in the mounting flanges of the sleeve. Check to make sure that there is enough sealant between the wall and the flanges to make the joint watertight. Additional

sealant must be applied as required. The sleeve must be anchored to the wall. All four mounting flanges must be fastened with two fasteners each to the outside wall. The gaps between the side flanges, and the top and bottom flanges must be sealed to the wall.

On the inside of the building, the gaps between the sleeve and the opening must be filled with insulation. This will help insulate the sleeve and prevent infiltration of any unwanted outdoor air. See Figure 5.

If the QTEC unit will be drained through the wall, the drain line must be installed through the wall. Information for the drain installation is contained in the QTEC Installation Instructions.

FIGURE 5
TYPICAL INSTALLATION WITH 14" MAX. WALL THICKNESS

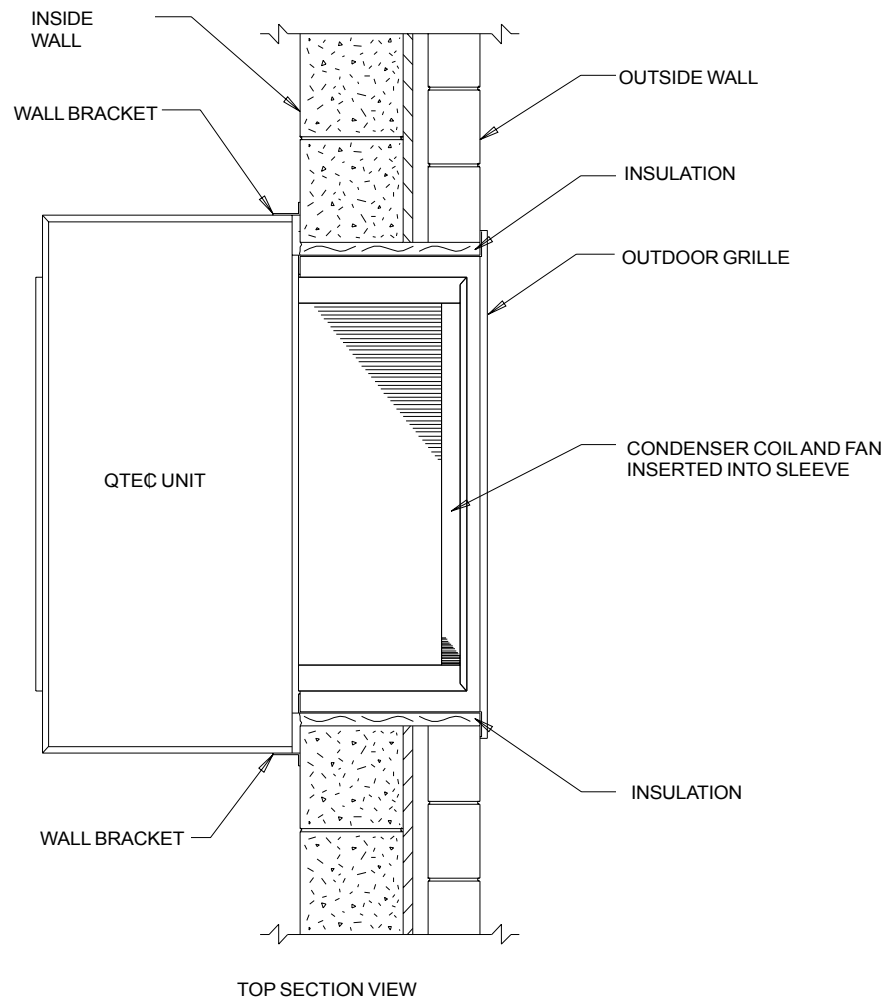

INSTALLATION WITH 16" THICK WALLS

When an application is required on a building with 16" wall, a Wall Sleeve model number QWS42A-16 is required.

The installation of the QWS42A-16 is similar to the QWS42A with one exception. A condenser fill plate is supplied with QWS42A-16, and is to be attached to the top of the outdoor coil housing on the QTEC unit. See Figure 6. To attach fill plate, remove the three screws on top of coil section, place condenser fill plate and secure with the three screws.

INSTALLATION WITH 19" THICK WALLS

When an application is required on a building with 19" wall, a Wall Sleeve model number QWS42A-19 is required.

The installation of the QWS42A-19 is similar to the QWS42A with one exception. A condenser fill plate is supplied with QWS42A-19, and is to be attached to the top of the outdoor coil housing on the QTEC unit. See Figure 6. To attach fill plate, remove the three screws on top of coil section, place condenser fill plate and secure with the three screws.

INSTALLATION WITH 23" THICK WALLS

When an application is required on a building with 23" wall, a Wall Sleeve model number QWS42A-23 is required.

The installation of the QWS42A-23 is similar to the QWS42A with one exception. A condenser fill plate is supplied with QWS42A-23, and is to be attached to the top of the outdoor coil housing on the QTEC unit. See Figure 6. To attach fill plate, remove the three screws on top of coil section, place condenser fill plate and secure with the three screws.

FIGURE 6
INSTALLATION OF CONDENSER FILL PLATE IN QWS42A-16, QWS42A-19 and QWS42-23 APPLICATION

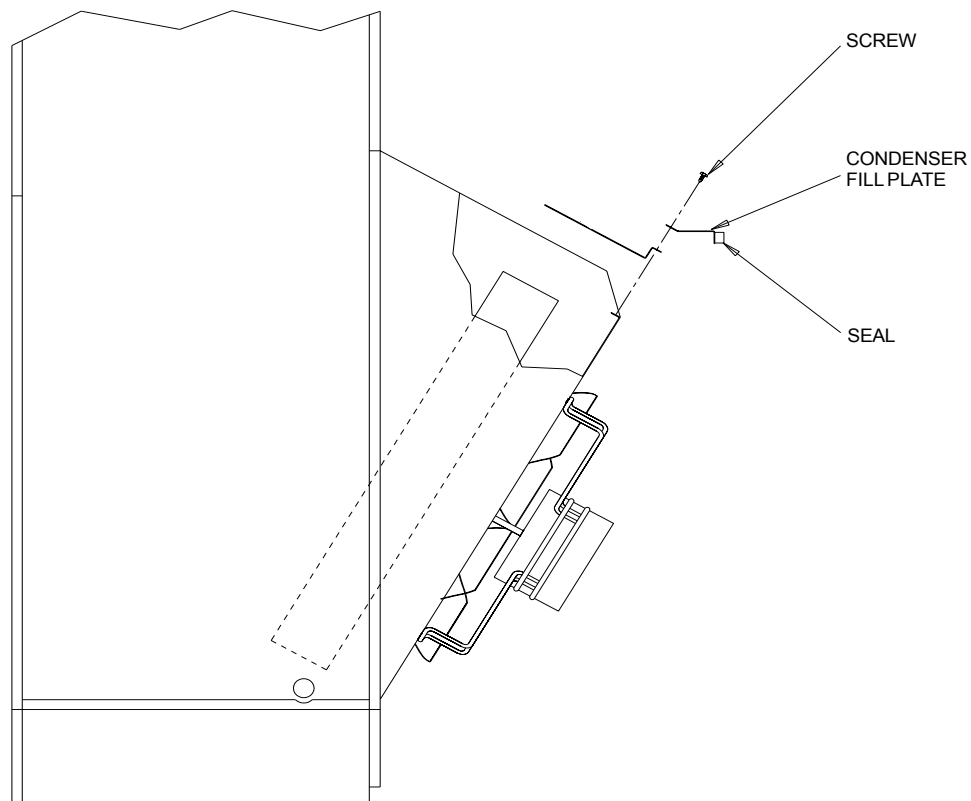

MIS-1023

ACCESSORY ITEM

The QCDS48 is a condensate disposal system for use on all QTEC models. The system consists of a drain box and a drain trap. The drain attaches to the side of the sleeve. The drain box has a rear drain and an overflow. The drain trap installs in the rear drain of the QTEC.

This system allows the QTEC unit to be installed or removed from the sleeve without connecting or disconnecting the drain line.

The installation of the QCDS48 requires that a recessed area next to the sleeve opening be built. See Figure 7 for dimensions of the recess for the drain box.

**FIGURE 7
QCDS48 CONDENSATE DISPOSAL SYSTEM**

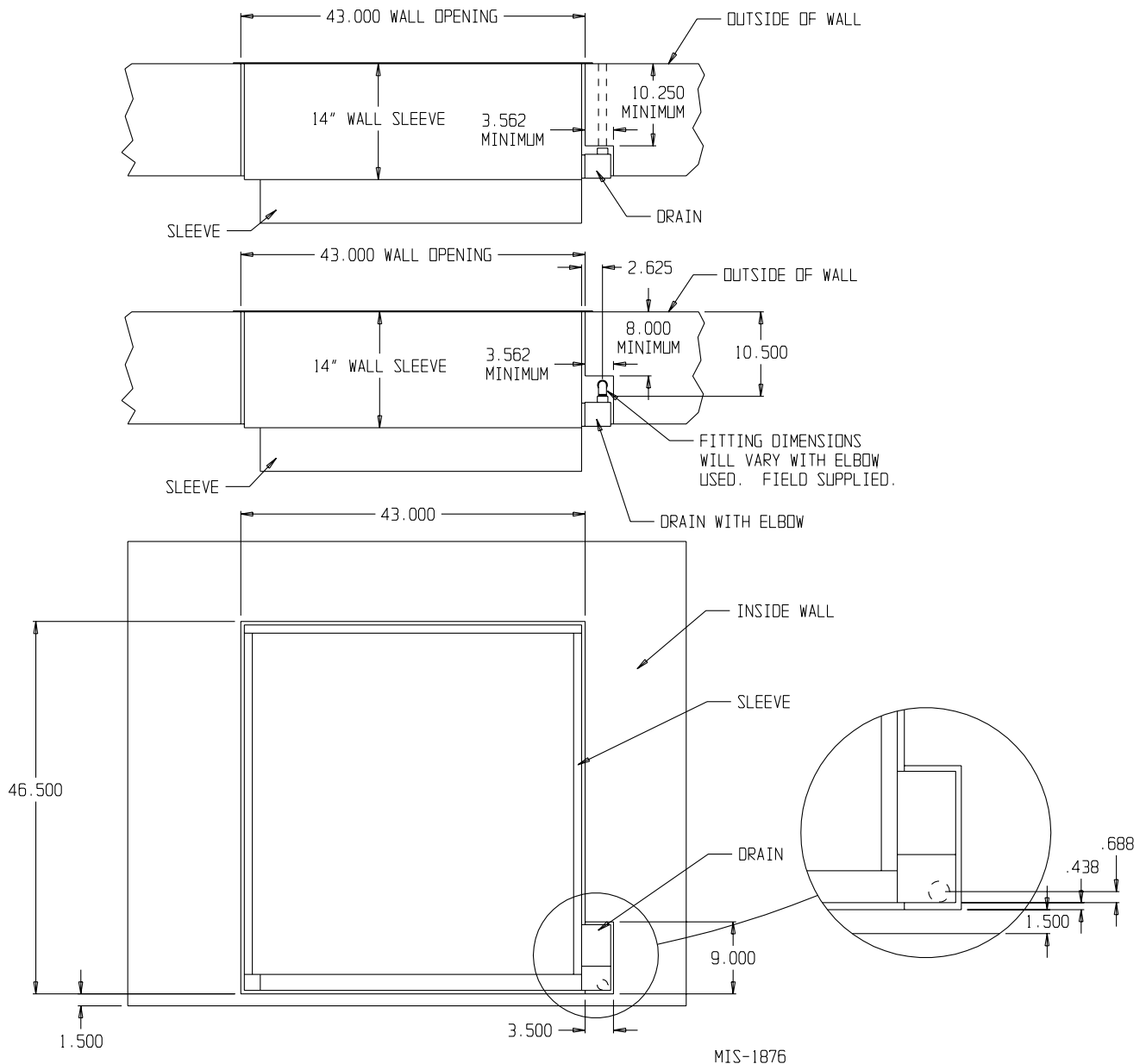

ATTACHMENT OF WALL SLEEVE TO QTEC UNIT

All Wall Sleeve Models covered in this manual are equipped with two different methods to attach the QTEC Model being applied.

The first method is with brackets supplied with the QTEC unit. These brackets are screwed to the sleeve side with six screws per side. This method can be used if adequate clearance is available on each side of the unit to drive the screws. If this method is used, the studs attached to the wall sleeve must be removed and discarded.

The second method is for installation where there is not adequate clearance to drive the screws into the cabinet sides. The attachment can be made from inside the unit. There are two threaded studs extending from the room side of the sleeve to matching holes in the unit rear

panel, and are secured with a 5/16" nut on each side. See Figure 3.

To use this method, discard the two side mounting brackets. Remove the nuts and washers from the threaded studs and retain for use later. Remove the lower cabinet door and locate the mating holes in the rear of the cabinet. It may be necessary to clear the holes of gasket material.

Roll unit into place making sure the unit is aligned from side to side and that studs have entered the holes in the cabinet back. Push unit back until the rubber seal on the rear of the cabinet touches the flange on the wall sleeve. Replace the washers and nuts previously removed from the studs. Tighten nuts until there is some compression of the gasket. Replace the lower cabinet panel.

**FIGURE 8
ATTACHING BASE ASSEMBLY TO SLEEVE
SHOWING CAULKING**

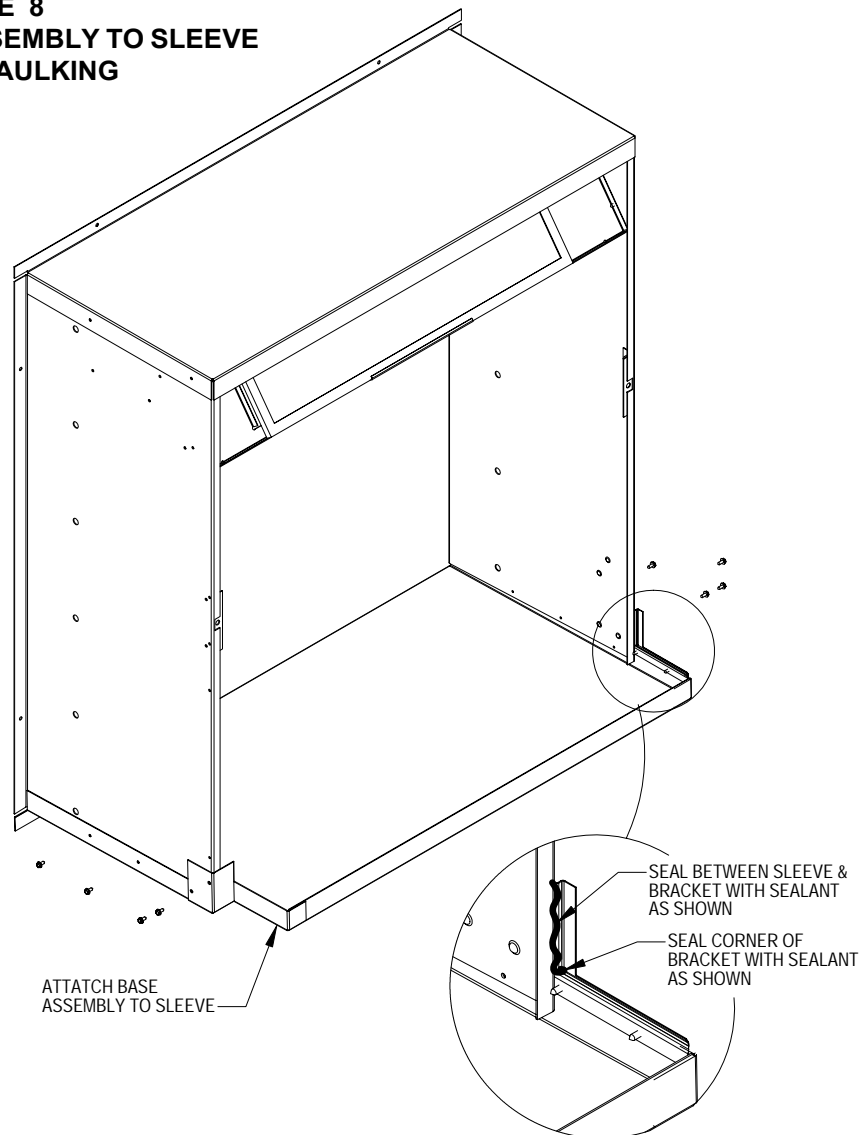

MIS-1848