INSTALLATION INSTRUCTIONS

WALL MOUNTED PACKAGE HEAT PUMP

MODELS
WH182
WH241



Bard Manufacturing Company
Bryan, Ohio 43506

*Since 1914...Moving ahead, just
as planned.*

Manual : 2100-322
File: Volume III Tab 17
Date: 12-15-97

Contents

Getting Other Informations and Publications	1
Wall Mount General Information	2
Heat Pump Wall Mount Model Nomenclature	2
Shipping Damage	2
General	2
Duct Work	4
Filters	5
Fresh Air Intake	5
Condensate Drain	5
Installation Instructions	6
Wall Mounting Information	6
Mounting the Unit	6
Wiring – Main Power	10
Wiring – Low Voltage Wiring	10
Compressor Cutoff Thermostat and Outdoor Thermostats	11
Heat Anticipation	12
Thermostat Indicator Lamps	12
Compressor Malfunction Light	12
Start Up	13
Important Installer Note	13
Crankcase Heaters	13
Service Hints	13
Sequence of Operation	13
Pressure Service Ports	14
Defrost Cycle	14
Troubleshooting	15
Solid State Heat Pump Control Troubleshooting Procedure	15
Checking Temperature Sensor Outside Unit Circuit	16
Fan Blade Setting Dimensions	17
Removal of Fan Shroud	17
Refrigerant Charge	17
Pressure Tables	18
Optional Accessories	19

Figures

Figure 1	Unit Dimensions	3
Figure 2	Fresh Air Damper Assembly	5
Figure 3	Mounting Instructions	7
Figure 4	Wall Mounting Instructions	8
Figure 5	Wall Mounting Instructions	8
Figure 6	Common Wall Mounting Installations	9
Figure 7	Unit 24V Terminal Board	10
Figure 8	Compressor Cutoff and Outdoor Thermostat Wiring	11
Figure 9	Start Up Procedure Decal	13
Figure 10	Defrost Control Board	14
Figure 11	Fan Blade Setting	17
Figure 12	Compressor Burnout Cleanup Procedure	13

Tables

Table 1	Electric Heat Table	1
Table 2	Fuse, HACR Breakers, Wire Size	4
Table 3	Thermostat Wire Size	11
Table 4	Wall Thermostat and Subbase Combinations	12
Table 5	Troubleshooting	15
Table 6	Fan Blade Dimensions	17
Table 7	System Charge Ratings	17
Table 8	Indoor Blower Performance	17
Table 9	Rated CFM and Rated ESP	17
Table 10	Maximum ESP of Operation	17
Table 11	Pressure Table	18
Table 12	Pressure Table	18
Table 13	Optional Accessories	19

Getting Other Information and Publications

These publications can help you install the air conditioner or heat pump. You can usually find these at your local library or purchase them directly from the publisher. Be sure to consult current edition of each standard.

National Electrical Code ANSI/NFPA 70

Standard for the Installation ANSI/NFPA 90A
of Air Conditioning and
Ventilating Systems

Standard for Warm Air ANSI/NFPA 90B
Heating and Air
Conditioning Systems

Load Calculation for ACCA Manual J
Residential Winter and
Summer Air Conditioning

Duct Design for Residential ACCA Manual D
Winter and Summer Air Conditioning
and Equipment Selection

For more information, contact these publishers:

ACCA — Air Conditioning Contractors of America
1712 New Hampshire Ave. N.W.
Washington, DC 20009
Telephone: (202) 483-9370
Fax: (202) 234-4721

ANSI — American National Standards Institute
11 West Street, 13th Floor
New York, NY 10036
Telephone: (212) 642-4900
Fax: (212) 302-1286

**ASHRAE — American Society of Heating
Refrigerating, and
Air Conditioning Engineers, Incorporated**
1791 Tullie Circle, N.E.
Atlanta, GA 30329-2305
Telephone: (404) 636-8400
Fax: (404) 321-5478

NFPA — National Fire Protection Association
Batterymarch Park
P.O. Box 9101
Quincy, MA 02269-9901
Telephone: (800) 344-3555
Fax: (617) 984-7057

WALL MOUNT GENERAL INFORMATION

HEAT PUMP WALL MOUNT MODEL NOMENCLATURE

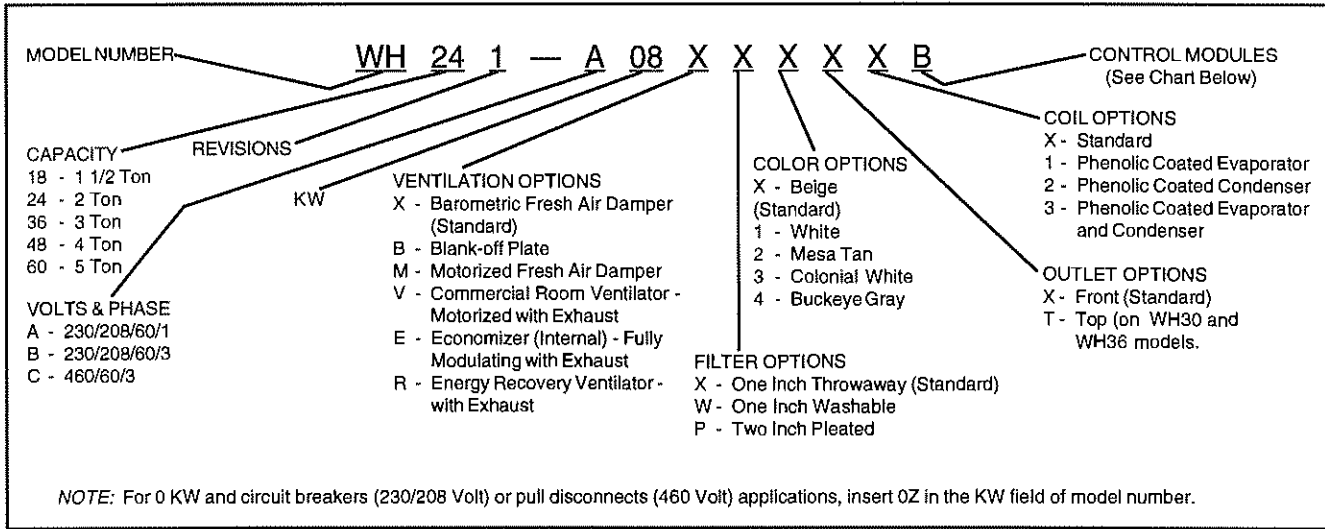

TABLE 1 – ELECTRIC HEAT TABLE

Models	WH182-A				WH241-A				WH241-B				WH241-C		
	240-1		208-1		240-1		208-1		240-3		208-3		460-3		
	KW	A	BTU	A	BTU	A	BTU	A	BTU	A	BTU	A	BTU	A	BTU
4	16.7	13650	14.4	10240	16.7	13650	14.4	10240							
8	33.3	27300	28.8	20475	33.3	27300	28.8	20475							
6									14.4	20500	12.5	15360	7.2	20475	

SHIPPING DAMAGE

Upon receipt of equipment, the carton should be checked for external signs of shipping damage. If damage is found, the receiving party must contact the last carrier immediately, preferably in writing, requesting inspection by the carrier's agent.

GENERAL

The equipment covered in this manual is to be installed by trained, experienced service and installation technicians.

The refrigerant system is completely assembled and charged. All internal wiring is complete.

The unit is designed for use with or without duct work. Flanges are provided for attaching the supply and return ducts.

These instructions explain the recommended method to install the air cooled self-contained unit and the electrical wiring connections to the unit.

These instructions and any instructions packaged with any separate equipment required to make up the entire air conditioning system should be carefully read before beginning the installation. Note particularly "Starting Procedure" and any tags and/or labels attached to the equipment.

While these instructions are intended as general recommended guide, they do not supersede any national and/or local codes in any way. Authorities having jurisdiction should be consulted before the installation is made. See Page 1 for information on codes and standards.

Size of unit for a proposed installation should be based on heat loss calculation made according to methods of Air

FIGURE 1 – UNIT DIMENSIONS

UNIT	WIDTH (W)	DEPTH (D)	HEIGHT (H)	SUPPLY		RETURN		E	F	G	I	J	K	L	M	N	O	P	Q
				A	B	C	B												
18 & 24	32-7/8	16-7/8	70-1/2	7-7/8	19-7/8	11-7/8	19-7/8	34-7/8	18-1/4	25-3/4	20-3/4	26-3/4	28	29-1/4	27	2-9/16	34	22-1/16	10-1/2

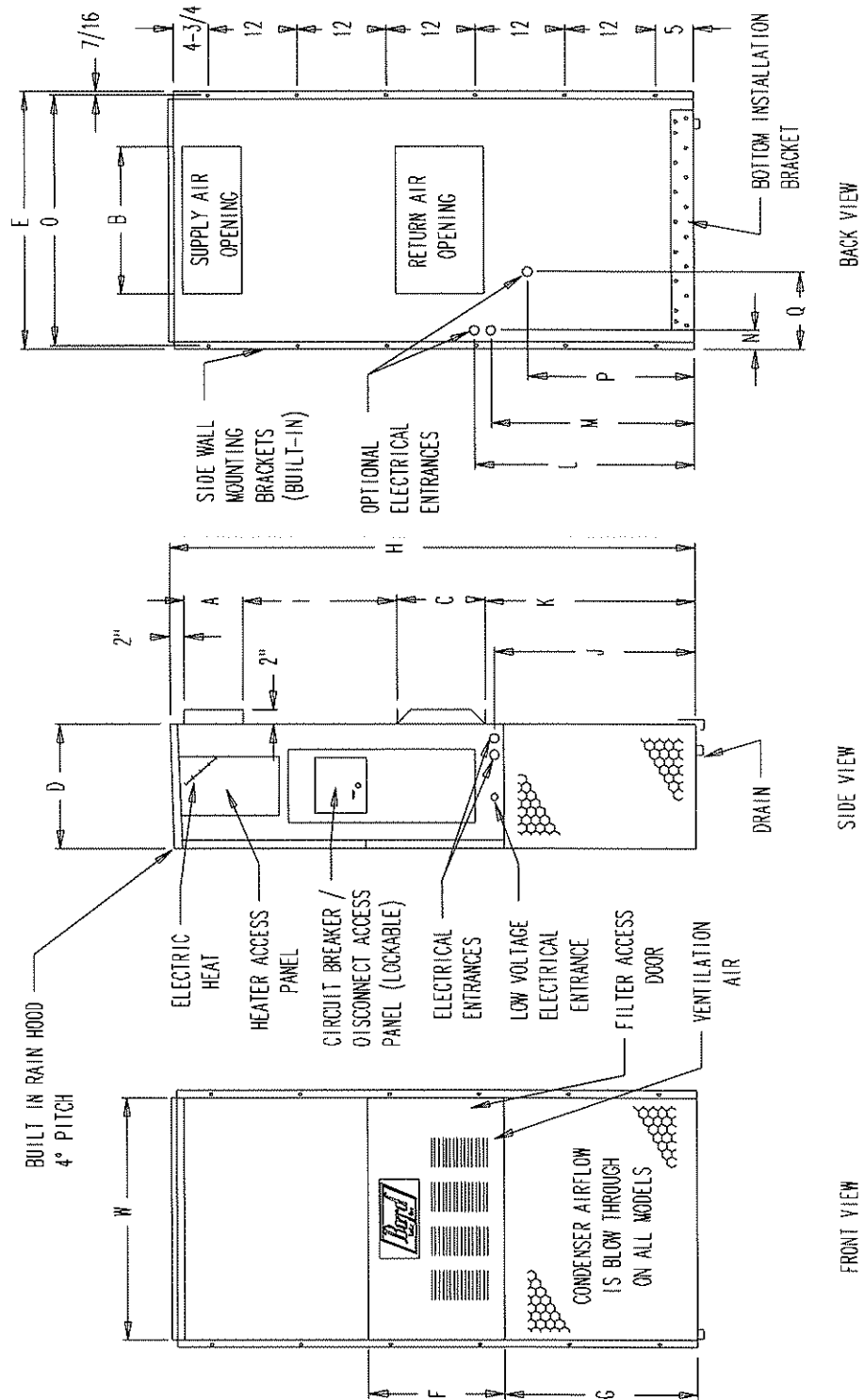

MIS-992

TABLE 2

SINGLE CIRCUIT						
Model	Rated Volts and Phase	No. Field Power Circuits	④ Minimum Circuit Ampacity	① Maximum External Fuse or Circuit Breaker	② Field Power Wire Size	② Ground Wire Size
WH182-A00, A0Z ③ A04 A08	230/208-1	1	17	25	12	12
		1	38	40	10	10
		1	59	60	6	10
WH241-A00, A0Z ③ A04 A08	230/208-1	1	18	25	12	12
		1	39	40	10	10
		1	60	60	6	10
WH241-B00, B0Z B06	230/208-1	1	15	20	12	12
		1	33	35	8	10
WH241-C00, C0Z C06	460-3	1	8	15	14	14
		1	17	20	12	12

- ① Maximum size of the time delay fuse or HACR type circuit breaker for protection of field wiring conductors.
- ② Based on 75° C copper wire. All wiring must conform to NEC and all local codes.
- ③ Maximum KW that can operate with heat pump on.
- ④ These "Minimum Circuit Ampacity" values are to be used for sizing the field power conductors. Refer to the National Electric Code (latest revision), article 310, for power conductor sizing. *CAUTION: When more than one field power conductor circuit is run through one conduit the conductors must be derated. Pay special attention to note 89 of table 310 regarding Ampacity Adjustment Factors when more than 3 are in a raceway.*

Conditioning Contractors of America (ACCA). The air duct should be installed in accordance with the Standards of the National Fire Protection Association for the Installation of Air Conditioning and Ventilating systems of Other Than Residence Type, NFPA No. 90A, and Residence Type Warm Air Heating and Air Conditioning Systems, NFPA No. 90B. Where local regulations are at a variance with instructions, installer should adhere to local codes.

DUCT WORK

Any heat pump is more critical of proper operating charge and an adequate duct system that a straight air conditioning unit. All duct work, supply and return, must be properly sized for the design air flow requirement of the equipment. Air Conditioning Contractors of America (ACCA) is an excellent guide to proper sizing. All duct work or portions thereof not in the conditioned space should be properly insulated in order to both conserve energy and prevent condensation or moisture damage.

Refer to Table 10 for maximum static pressure available for duct design.

Design the duct work according to methods given by the Air Conditioning Contractors of America (ACCA). When duct runs through unheated spaces, it should be insulated with a minimum of one inch of insulation. Use insulation with a vapor barrier on the outside of the insulation. Flexible joints should be used to connect the duct work to the equipment in order to keep the noise transmission to a minimum.

A 1/4 inch clearance to combustible material for the first three feet of duct attached to the outlet air frame is required. See Pages Wall Mounting Instructions and Figure 3 for further details.

Ducts through the walls must be insulated and all joints taped or sealed to prevent air or moisture from entering the wall cavity.

CAUTION: Some installations may not require any return air duct. A metallic return air grille is required with installations not requiring a return air duct. The spacing between louvers on the grille shall not be larger than 5/8 inches.

Any grille that meets the 5/8 inch lower criteria may be used. It is recommended that Bard Return Air Grille Kit RG2 thru RG5 or RFG2 thru RFG5 be installed when no return duct is used. Contact distributor or factory for ordering information. If using a return air filter grille, filters must be of sufficient size to allow a maximum velocity of 400 fpm.

NOTE: If no return air duct is used, applicable installation codes may limit this cabinet to installation only in a single story structure.

FILTERS

A 1 inch throwaway filter is supplied with each unit. The filter slides into position making it easy to service. This filter can be serviced from the outside by removing the service door. A 1 inch washable filter and a 2 inch pleated filter are also available as optional accessories. The internal filter brackets are adjustable to accommodate the 2 inch filter by loosening two (2) screws in each bracket assembly and sliding the brackets apart to the required width and retightening the four (4) screws.

FRESH AIR INTAKE

All units are built with fresh air inlet slots punched in the service panel.

If the unit is equipped with a fresh air damper assembly, the assembly is shipped already attached to the unit. The damper blade is locked in the closed position. To allow the damper to operate, the maximum and minimum blade position stops must be installed. See Figure 2.

All capacity, efficiency, and cost of operation information as required for Department of Energy "Energyguide" Fact

Sheet is based upon the fresh air blank-off plate in place and is recommended for maximum energy efficiency.

The blank-off plate is available upon request from the factory and is installed in place of the fresh air damper shipped with each unit.

FIGURE 2 – FRESH AIR DAMPER ASSEMBLY

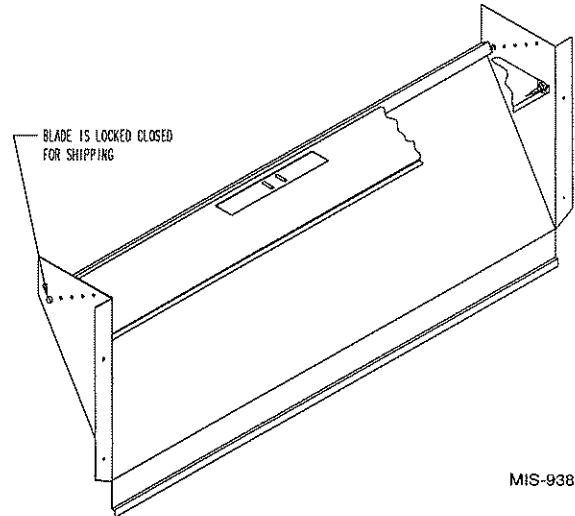

CONDENSATE DRAIN

A plastic drain hose extends from the drain pan at the top of the unit down to the unit base. There are openings in the unit base for the drain hose to pass through. In the event the drain hose is connected to a drain system of some type, it must be an open or vented type system to assure proper drainage.

INSTALLATION INSTRUCTIONS

WALL MOUNTING INFORMATION

1. These units are secured by wall mounting brackets which secure the unit to the outside wall surface at both sides. A bottom mounting bracket is provided for ease of installation, but is not required.
2. On wood frame walls, the wall construction must be strong and rigid enough to carry the weight of the unit without transmitting any unit vibration.
3. Concrete block walls must be thoroughly inspected to insure that they are capable of carrying the weight of the unit being installed.
4. The unit is suitable for 0 inch clearance from the unit, and from the supply and return air ducts.

MOUNTING THE UNIT

1. Two holes for the supply and return air openings must be cut through the wall as shown in Figure 3.
2. Locate and mark lag bolt locations and bottom mounting bracket location, if desired. See Figure 3.

3. Mount bottom mounting bracket, if used.
4. Hook top rain flashing under back bend of top. Top rain flashing is shipped secured to the right side of the back.
5. Position unit in opening and secure with 5/16 lag bolts. Use 5/16" diameter flat washers on the lag bolts.
6. Secure rain flashing to wall and caulk across entire length of top. See Figure 3.
7. For additional mounting rigidity, the return air and supply air frames or collars can be drilled and screwed or welded to the structural wall itself (depending upon wall construction). Be sure to observe required clearance if combustible wall.
8. On side by side installations, maintain a minimum of 20 inches clearance on right side of unit to allow access to control panel and heaters, and to allow proper airflow to the outdoor coil. Additional clearance may be required to meet local or national codes.

FIGURE 3 – MOUNTING INSTRUCTIONS

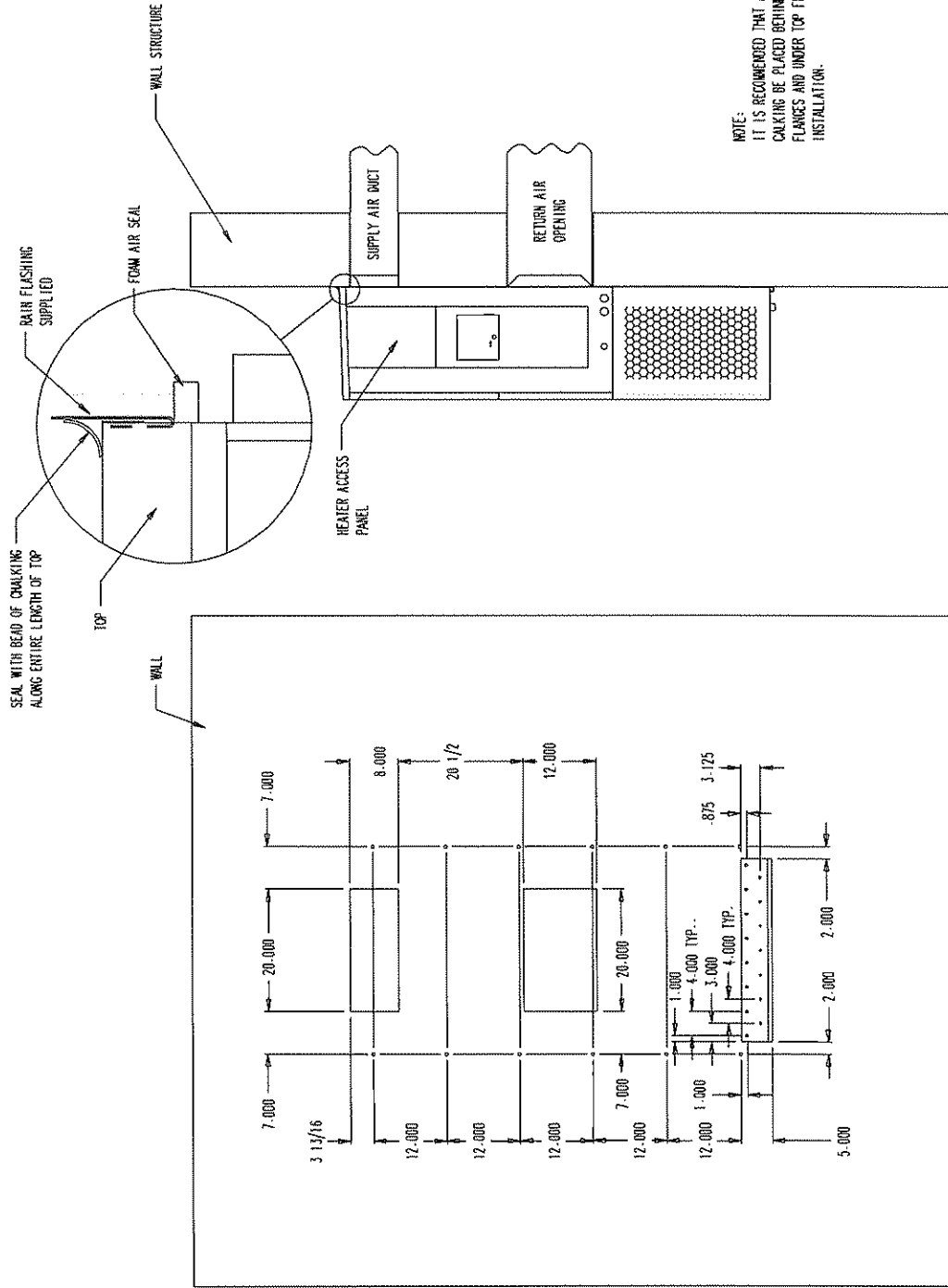

MIS-353

FIGURE 4 – WALL MOUNTING INSTRUCTIONS

SEE FIGURE 3 – MOUNTING INSTRUCTIONS

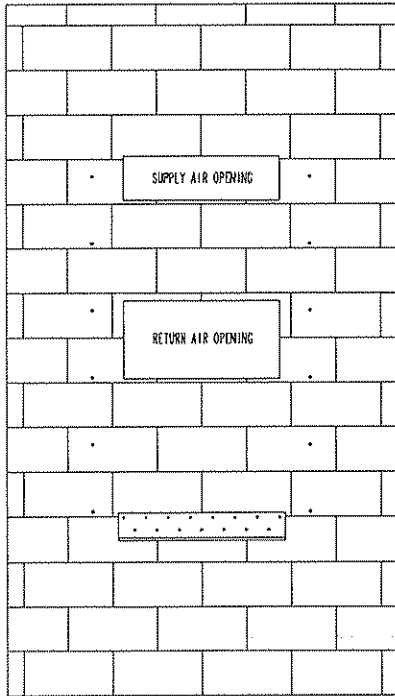

CONCRETE BLOCK WALL INSTALLATION

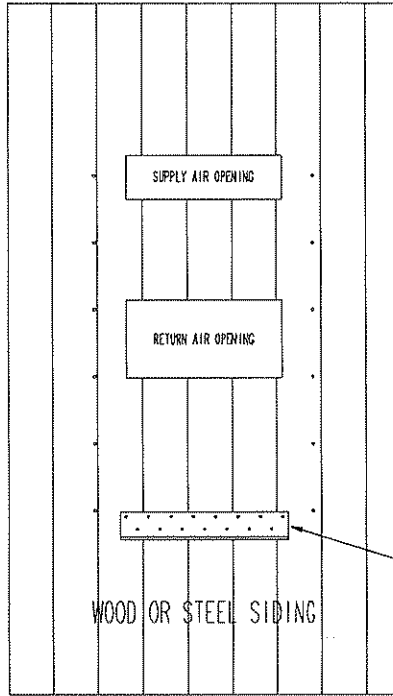

WOOD FRAME WALL INSTALLATION

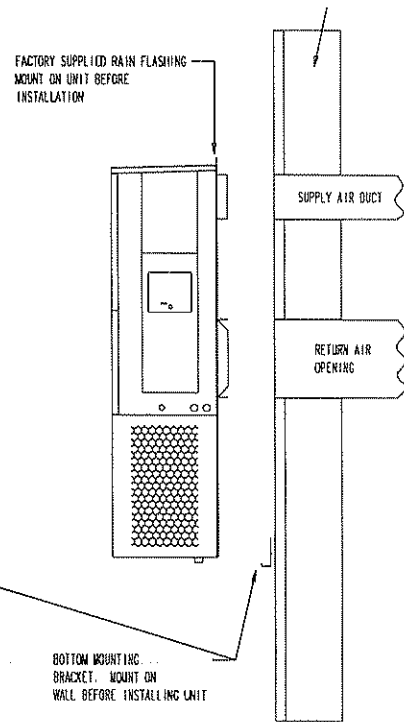

MIS-548

FIGURE 5 – WALL MOUNTING INSTRUCTIONS

SEE UNIT DIMENSIONS, FIGURE 1, FOR ACTUAL DIMENSIONS

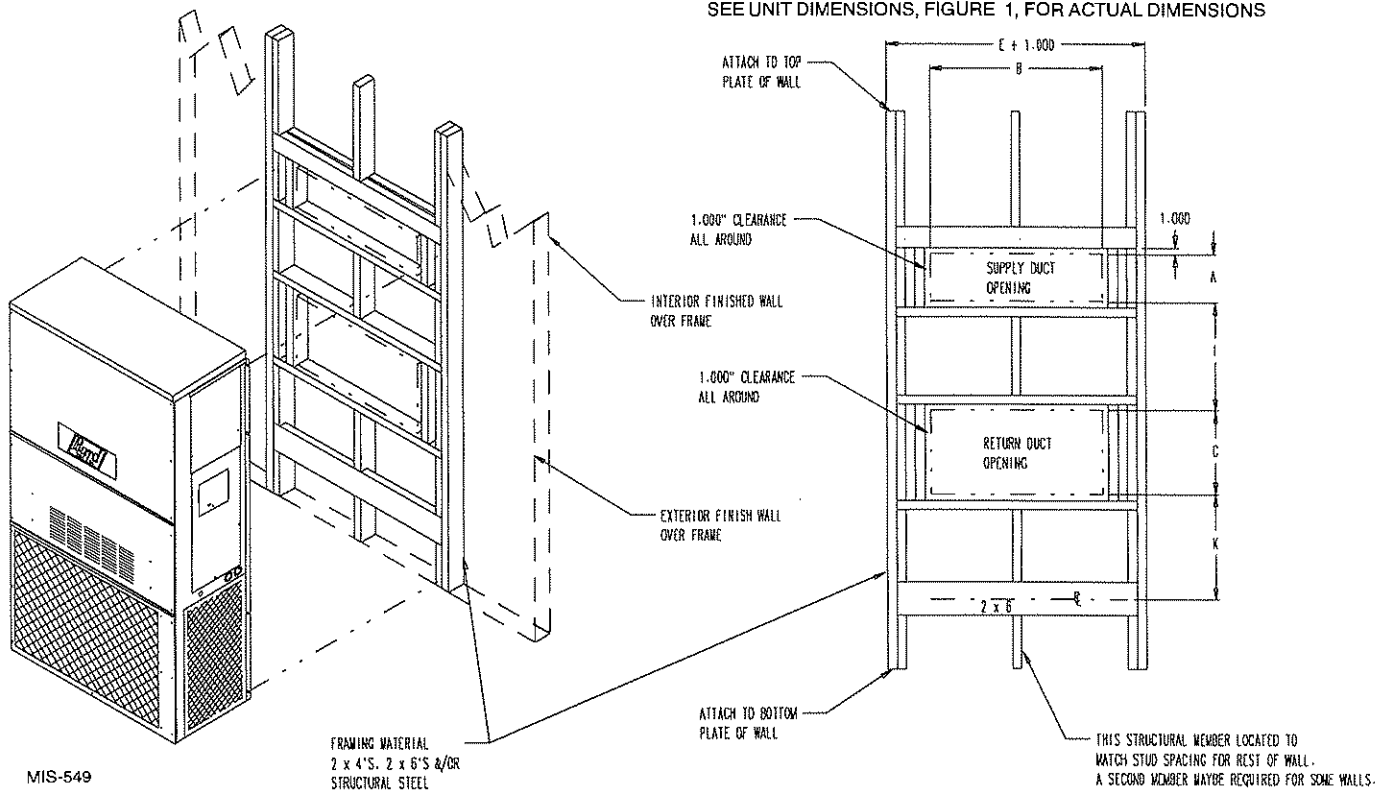

MIS-549

FIGURE 6 – COMMON WALL MOUNTING INSTALLATIONS

MIS-550

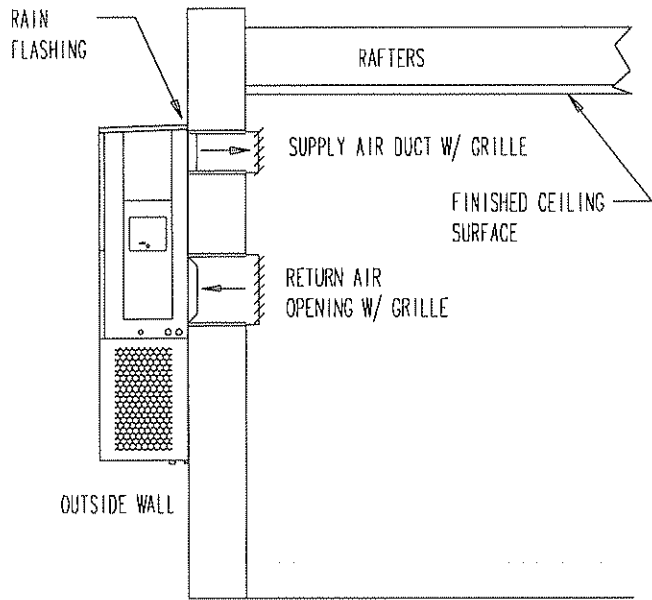

FREE AIR FLOW
NO DUCT

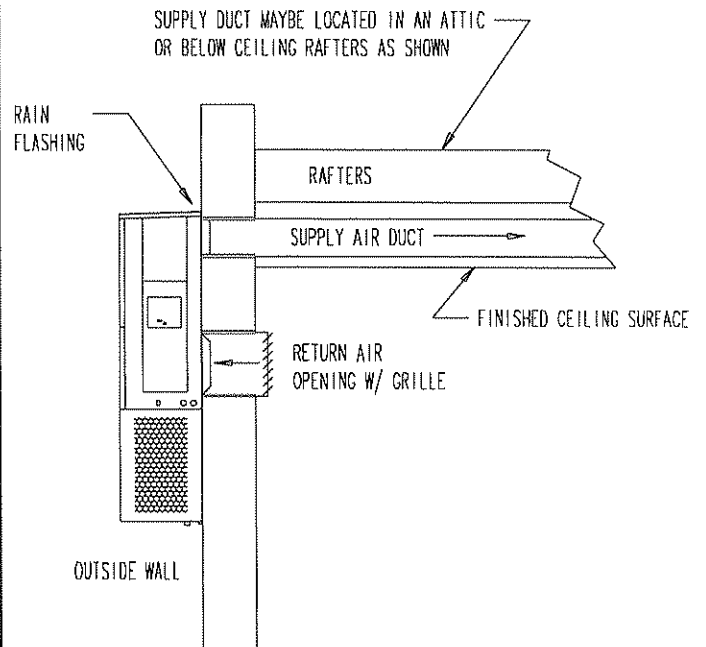

DUCTED SUPPLY
RETURN AT UNIT

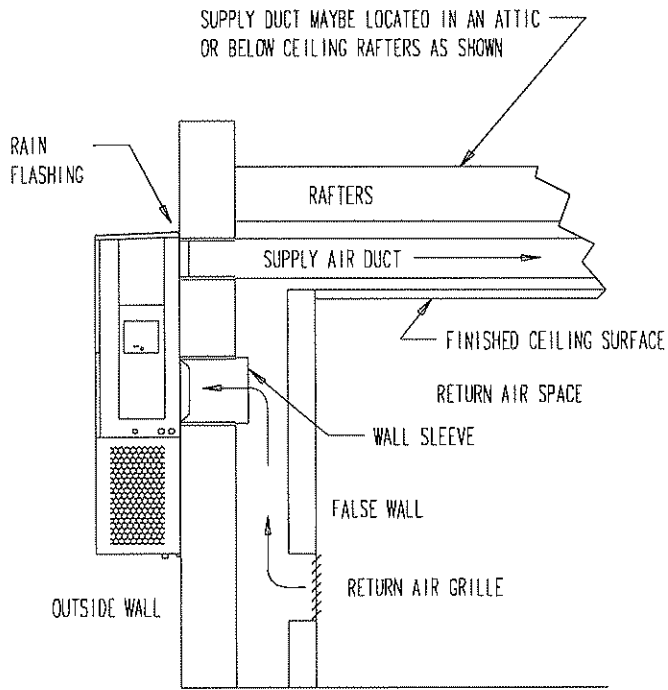

FALSE WALL INSTALLATION

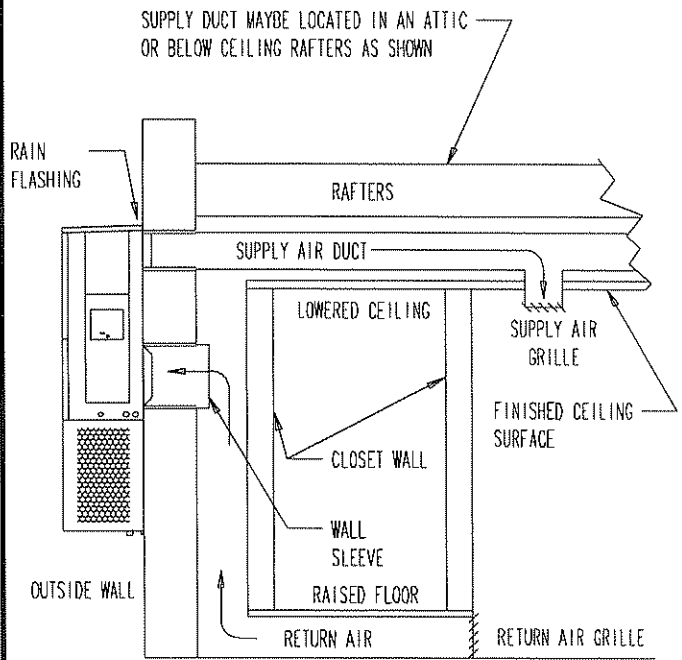

CLOSET INSTALLATION

WIRING – MAIN POWER

Refer to the unit rating plate for wire sizing information and maximum fuse or “HACR” type circuit breaker size. Each outdoor unit is marked with a “Minimum Circuit Ampacity”. This means that the field wiring used must be sized to carry that amount of current. Depending on the installed KW of electric heat, there may be two field power circuits required. If this is the case, the unit serial plate will so indicate. All models are suitable only for connection with copper wire. Each unit and/or wiring diagram will be marked “Use Copper Conductors Only”. **These instructions must be adhered to.** Refer to the National Electrical code (NEC) for complete current carrying capacity data on the various insulation grades of wiring material. All wiring must conform to NEC and all local codes.

The electrical data lists fuse and wire sizes (75° C copper) for all models, including the most commonly used heater sizes. Also shown are the number of field power circuits required for the various models with heaters.

The unit rating plate lists a “Maximum Time Delay Relay Fuse” or “HACR” type circuit breaker that is to be used with the equipment. The correct size must be used for proper circuit protection and also to assure that there will be no nuisance tripping due to the momentary high starting current of the compressor motor.

The disconnect access door on this unit may be locked to prevent unauthorized access to the disconnect. To convert for the locking capability, bend the tab located in the bottom left hand corner of the disconnect opening under the disconnect access panel straight out. This tab will now line up with the slot in the door. When shut a padlock may be placed through the hole in the tab preventing entry.

WIRING – LOW VOLTAGE WIRING

230/208V, 1 phase and 3 phase equipment dual primary voltage transformers. All equipment leaves the factory wired on 240V tap. For 208V operation, reconnect from 240V to 208V tap. The acceptable operating voltage range for the 240 and 208V taps are:

TAP	RANGE
240	253 - 216
208	220 - 187

NOTE: The voltage should be measured at the field power connection point in the unit and while the unit is operating at full load (maximum amperage operating condition).

Nine (9) wires should be run from thermostat subbase to the 24V terminal board in the unit. A nine conductor, 18 gauge copper, color-coded thermostat cable is recommended. The connection points are shown in Figure 7.

FIGURE 7 – UNIT 24V TERMINAL BOARD

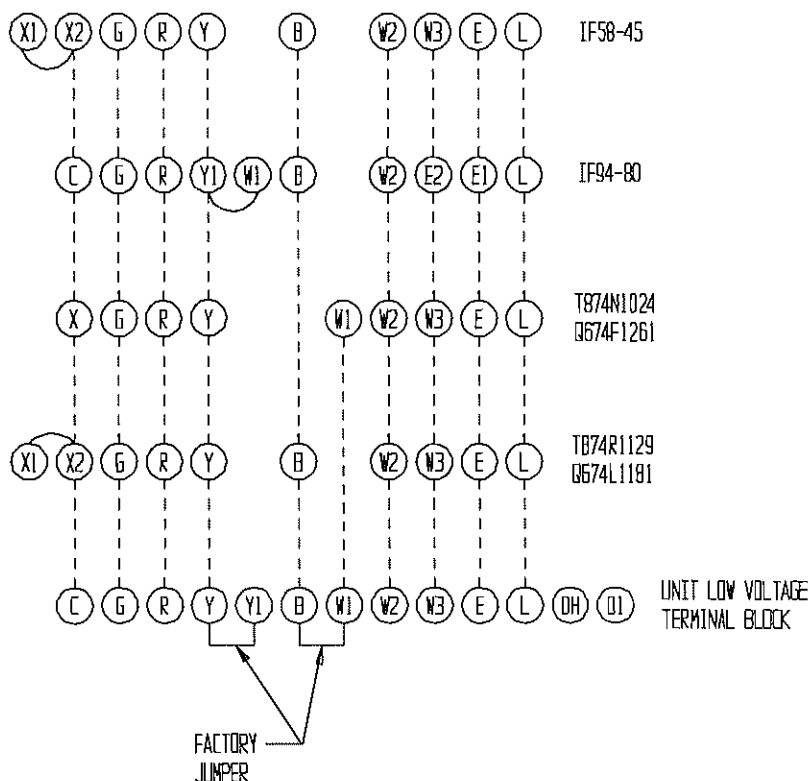

MIS-440

IMPORTANT NOTE: Only the thermostat and subbase combinations as shown in Figure 7 will work with this equipment. The thermostat and subbase **must** be matched, and the correct operation can be assured only by proper selection and application of these parts.

TABLE 3 – THERMOSTAT WIRE SIZE

Transformer VA	FLA	Wire Gauge	Maximum Distance In Feet
55	2.3	20 gauge	45
		18 gauge	60
		16 gauge	100
		14 gauge	160
		12 gauge	250

COMPRESSOR CUTOFF THERMOSTAT AND OUTDOOR THERMOSTATS

Heat pump compressor operation at outdoor temperatures below 0° F are neither desirable nor advantageous in terms of efficiency. Since most equipment at time of manufacture is not designated for any specific destination of the country and most of the equipment is installed in areas not approaching the lower outdoor temperature range, the compressor cutoffs are not factory installed.

Outdoor thermostats are available to hold off various banks of electric heat until needed as determined by outdoor temperature. The set point of either type of thermostat is variable with geographic region and sizing of the heating equipment to the structure. Utilization of the Heating Application Data and the heat loss calculation of the building are useful in determining the correct set points.

See Figure 8 for compressor cutoff and outdoor thermostat wiring.

FIGURE 8 – COMPRESSOR CUTOFF AND OUTDOOR THERMOSTAT WIRING

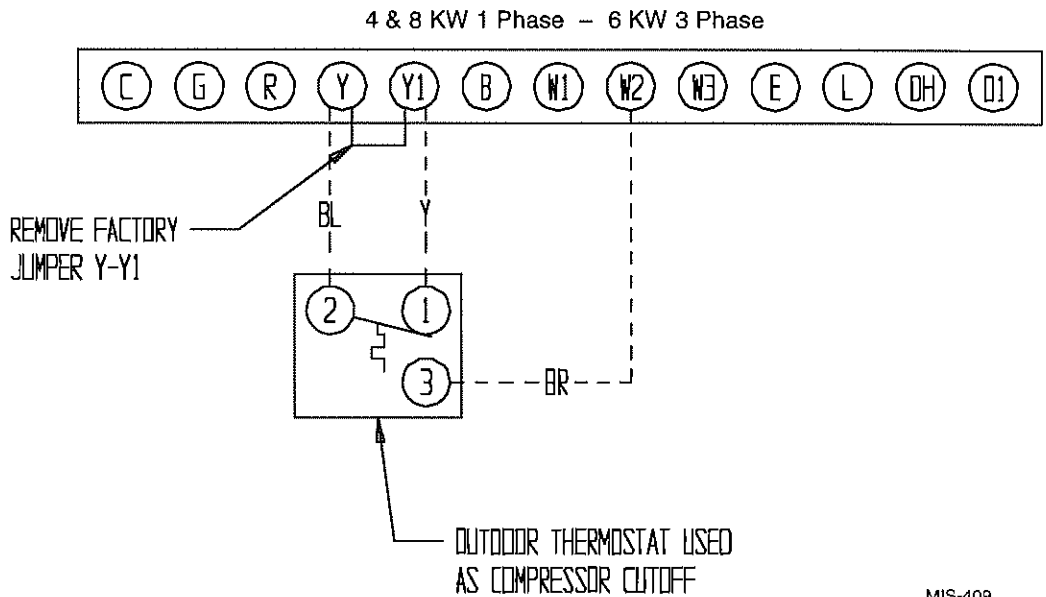

MIS-409

HEAT ANTICIPATION

Group A and Group B thermostats shown in Table 4 have a fixed heat anticipator for stage 1 with no adjustment required. Stage 2 has an adjustable anticipator for the W2 connection and fixed for the W3 connection. Both the W2 and W3 circuits are controlled by the stage 2 bulb. The only heat anticipator that needs to be checked is stage 2 and it should be set to match the load carried by the W2 circuit. The normal factory wiring provides for only one electric heat contactor to be controlled by W2, and the anticipator should be set at .40A. If special field wiring is done, it is best to actually measure the load but a good rule is .40A for *each* heat contactor controlled by W2.

TABLE 4 – WALL THERMOSTAT AND SUBBASE COMBINATIONS

Group	Thermostat	Subbase	Predominant Features
A	8403-017 (T874R1129)	8404-009 (Q674L1181)	Heat or Cool ① No Auto
B	8403-018 (T874N1024)	8404-010 (Q674F1261)	Automatic Heat-Cool ② Changeover Position
	8403-034 (1F94-80)	---	Programmable Electronic
	8403-024 (1F58-45)	---	Programmable Electronic

- ① No automatic changeover position – must manually place in heat or cool. Reversing valve remains energized at all times system switch is in heat position (except during defrost cycle). No pressure equalization noise when thermostat is satisfied on either heating or cooling.
- ② Allows thermostat to control both heating and cooling operation when set in “Auto” position. Reversing valve de-energizes at end of each “ON” heating cycle.

IMPORTANT NOTE: *The thermostat and subbase combinations shown above incorporate the following features: Man-Auto fan switch, Off-Heat-Cool-Em. Heat Switch, and two (2) indicator lamps; one for emergency heat and one for compressor malfunction.*

THERMOSTAT INDICATOR LAMPS

The green lamp marked “Check” will come on if there is any problem that prevents the compressor from running when it is supposed to be.

COMPRESSOR MALFUNCTION LIGHT

Actuation of the green “Check” lamp is accomplished by a relay output from the heat pump control board which is factory installed. Any condition such as loss of charge, high head pressure, etc., that will prevent compressor from operating will cause green lamp to activate. This is a signal to the operator of the equipment to place system in emergency heat position.

IMPORTANT INSTALLER NOTE

For improved start up performance, wash the indoor coil with a dish detergent.

CRANKCASE HEATERS

WH241 units are provided with compressor crankcase heat.

These models have an insertion well-type heater located in the lower section of the compressor housing. This is a self-regulating type heater that draws only enough power to maintain the compressor at a safe temperature.

Some form of crankcase heat is essential to prevent liquid refrigerant from migrating to the compressor causing oil pump out on compressor start up and possible valve failure due to compressing a liquid.

The decal in Figure 9 is affixed to all outdoor units detailing start up procedure. *This is very important. Please read carefully.*

SERVICE HINTS

1. Caution homeowner to maintain clean air filters at all times. Also, not to needlessly close off supply and return air registers. This reduces air flow through the system which shortens equipment service life as well as increasing operating costs.
2. Switching to heating cycle at 75° F or higher outside temperature may cause a nuisance trip of the remote reset high pressure switch. Turn thermostat off, then on, to reset the high pressure switch.
3. The heat pump wall thermostats perform multiple functions. Be sure that all function switches are correctly set for the desired operating mode before trying to diagnose any reported service problems.
4. Check all power fuses or circuit breakers to be sure they are the correct rating.
5. Periodic cleaning of the outdoor coil to permit full and unrestricted airflow circulation is essential.

SEQUENCE OF OPERATION

COOLING – Circuit R-Y makes at thermostat pulling in compressor contactor, starting the compressor and outdoor motor. The G (indoor motor) circuit is automatically completed on any call for cooling operation or can be energized by manual fan switch on subbase for constant air circulation.

HEATING – a 24V solenoid coil on reversing valve controls heating cycle operation. Two thermostat options, one allowing “Auto” changeover from cycle to cycle, and the other constantly energizing solenoid coil during heating season and thus eliminating pressure equalization noise

FIGURE 9

IMPORTANT

THESE PROCEDURES MUST BE FOLLOWED AT INITIAL START UP AND AT ANY TIME POWER HAS BEEN REMOVED FOR 12 HOURS OR LONGER.

TO PREVENT COMPRESSOR DAMAGE WHICH MAY RESULT FROM THE PRESENCE OF LIQUID REFRIGERANT IN THE COMPRESSOR CRANKCASE:

1. MAKE CERTAIN THE ROOM THERMOSTAT IS IN THE “OFF” POSITION. (THE COMPRESSOR IS NOT TO OPERATE.)
2. APPLY POWER BY CLOSING THE SYSTEM DISCONNECT SWITCH. THIS ENERGIZES THE COMPRESSOR HEATER WHICH EVAPORATES THE LIQUID REFRIGERANT IN THE CRANKCASE.
3. ALLOW 4 HOURS OR 60 MINUTES PER POUND OF REFRIGERANT IN THE SYSTEM AS NOTED ON THE UNIT RATING PLATE, WHICHEVER IS GREATER.
4. AFTER PROPERLY ELAPSED TIME THE THERMOSTAT MAY BE SET TO OPERATE THE COMPRESSOR.
5. EXCEPT AS REQUIRED FOR SAFETY WHILE SERVICING — **DO NOT OPEN SYSTEM DISCONNECT SWITCH.**

7961-061

except during defrost, are to be used. On “Auto” option, a circuit is completed from R-W1 and R-Y on each heating “ON” cycle energizing reversing valve solenoid and pulling in compressor contactor starting compressor and outdoor motor. R-G also make starting indoor blower motor. Heat Pump heating cycle now in operation. The second option has no “Auto” changeover position, but instead energizes the reversing valve solenoid constantly whenever the system switch on subbase is placed in “Heat” position, the “B” terminal being constantly energized from R. A thermostat demand for heat completes R-Y circuit pulling in compressor contactor starting compressor and outdoor motor. R-G also make starting indoor blower motor.

PRESSURE SERVICE PORTS

High and low pressure service ports are installed on all units so that the system operating pressures can be observed. Pressure curves can be found later in the manual covering all models on both cooling and heating cycles. It is imperative to match the correct pressure curve to the unit by model number.

DEFROST CYCLE

The defrost cycle is controlled by temperature and time on the solid state heat pump control. See Figure 10.

When the outdoor temperature is in the lower 40° F temperature range or colder, the outdoor coil temperature is 32° F or below. This coil temperature is sensed by the coil sensor mounted near the bottom of the outdoor coil. Once coil temperature reaches 30° F or below, the coil sends a signal to the control logic of the heat pump control and the defrost timer will start.

After 60 (90 or 30) minutes at 30° F or below, the heat pump control will place the system in the defrost mode.

During the defrost mode, the refrigerant cycle switches back to the cooling cycle, the outdoor motor stops, electric heaters

are energized, and hot gas passing through the outdoor coil melts any accumulated frost. When the temperature rises to approximately 57° F, the coil sensor will send a signal to the heat pump control which will return the system to heating operations automatically.

If some abnormal or temporary condition such as a high wind causes the heat pump to have a prolonged defrost cycle, the heat pump control will restore the system to heating operation automatically after 10 minutes.

There are three settings on the heat pump control – 30 minute, 60 minute, and 90 minute. Most models are shipped wired on the 60 minute setting for greatest operating economy. If special circumstances require a change to another time, remove wire connected to terminal 60 and reconnect to desired terminal.

There is a cycle speed up jumper on the control. This can be used to reduce the time between defrost cycle operation without waiting for time to elapse.

There is an initial defrost (sen jmp) jumper on the control that can be used at any outdoor ambient during the heating cycle to simulate a 0° coil temperature. This can be used to check defrost operation of the unit without waiting for the outdoor ambient to fall into the defrost region.

FIGURE 10 – DEFROST CONTROL BOARD

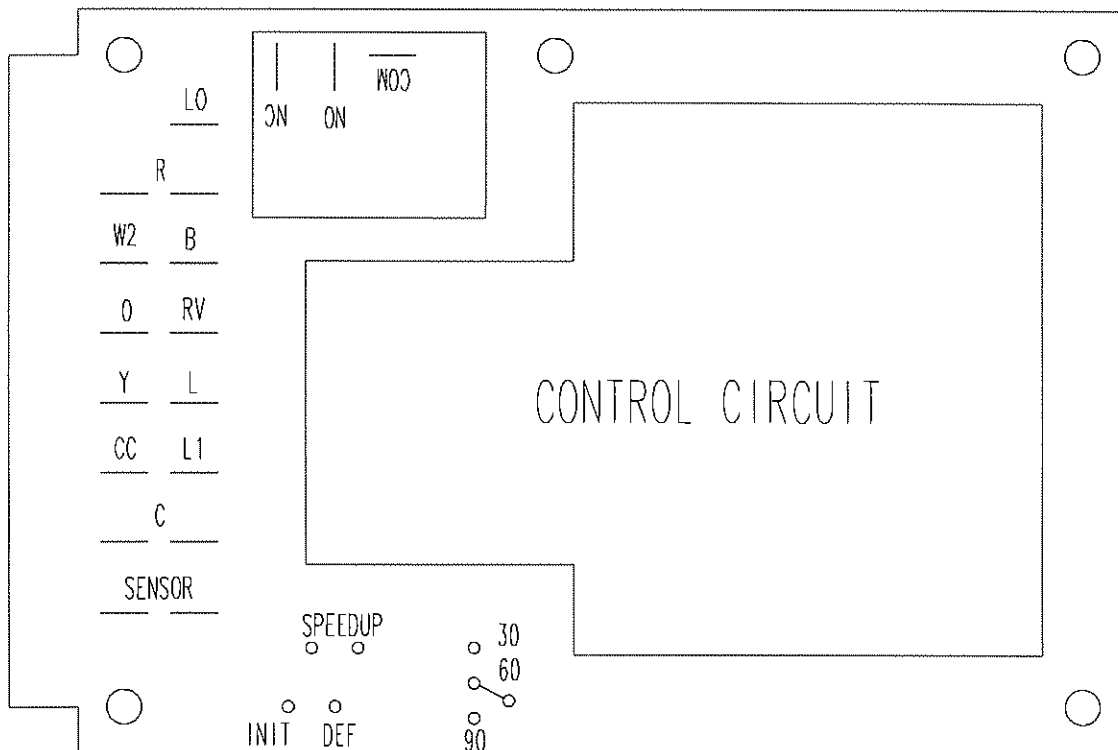

MIS-1174

TROUBLESHOOTING

SOLID STATE HEAT PUMP CONTROL TROUBLESHOOTING PROCEDURE

1. Turn on AC power supply to indoor and outdoor units.
2. Turn thermostat blower switch to “fan on” – the indoor blower should start. (If it doesn’t, troubleshoot indoor unit and correct problem.)
3. Turn thermostat blower switch to “auto” position. Indoor blower should stop.

4. Set system switch to “heat” or “cool”. Adjust thermostat to call for heat or cool – the indoor blower, compressor and outdoor fan should start.

NOTE: If there was no power to 24 volt transformer, the compressor and outdoor fan motor will not start for 5 minutes. This is because of the compressor short cycle protection.

TABLE 5 – TROUBLESHOOTING

SYMPTOM	POSSIBLE CAUSES	WHAT TO CHECK	HOW TO CHECK OR REPAIR
Compressor contactor does not energize (cooling or heating)	Control circuit wiring	Check for R connection at unit, and 24V between R-C	Run R connection to outdoor unit to power heat pump control
	Compressor lock out	1. Check for 24V between L1-C on heat pump control 2. Check across high pressure switch.	1. If no voltage between L-C turn thermostat off and on again to reset high pressure switch. 2. If high pressure switch is open and will not reset, replace high pressure switch.
	Compressor short cycle protection	Check for 24V between CC-C and Y-C on heat pump control	If no voltage between CC-C, jumper speed up terminal and within 10 seconds power should appear between CC-C. Remove jumper after 10 seconds.
	Heat pump control defective	Check all other possible causes. Manual 2100-065	Replace heat pump control
	Contactors defective	Check for open or shorted coil winding.	Replace contactor
Fan outdoor motor does not run (cooling or heating except during defrost)	Motor defective	Check for open or shorted motor winding	Replace motor
	Motor capacitor defective	Check capacitor rating. Check for open or shorted capacitor.	Replace capacitor
	Heat pump control defective	Check across fan relay on heat pump control (Com-NC)	Replace heat pump control
Reversing valve does not energize (heating only)	Reversing valve solenoid coil defective	Check for open or shorted coil	Replace solenoid coil
	Heat pump control defective	Check for 24V between RV-C and B-C	1. Check control circuit wiring 2. Replace heat pump control
Unit will not go into defrost (heating only)	Temperature sensor or heat pump control defective	Disconnect temperature sensor from board and jumper across speed up terminals and sen jump terminals. This should cause the unit to go through a defrost cycle within one minute.	1. If unit goes through defrost cycle, replace temperature sensor 2. If unit does not go through defrost cycle, replace heat pump control
Unit will not come out of defrost (heating only)	Temperature sensor or heat pump control defective	Jumper across speed up terminals. This should cause the unit to come out of defrost within one minute.	1. If unit comes out of defrost cycle, replace temperature sensor. 2. If unit does not come out of defrost cycle, replace heat pump control.

CHECKING TEMPERATURE SENSOR OUTSIDE UNIT CIRCUIT.

1. Disconnect temperature sensor from outdoor coil.
2. Use an ohmmeter and measure the resistance of the sensor. Also use ohmmeter to check for short or open.
3. Check resistance reading to chart of resistance use ambient temperature. (Tolerance of part is $\pm 10\%$.)
4. If sensor resistance reads very low, then sensor is shorted and will not allow proper operation of the heat pump control.
5. If sensor is out of tolerance, shorted, open or reads very low ohms then it should be replaced

TEMPERATURE F VS RESISTANCE R OF TEMPERATURE SENSOR

F	R	F	R	F	R
-25.0	196871	25.0	39898	75.0	10501
-24.0	190099	26.0	38757	76.0	10247
-23.0	183585	27.0	37652	77.0	10000
-22.0	177318	28.0	36583	78.0	9760
-21.0	171289	29.0	35548	79.0	9526
-20.0	165487	30.0	34545	80.0	9299
-19.0	159904	31.0	33574	81.0	9077
-18.0	154529	32.0	32634	82.0	8862
-17.0	149355	33.0	31723	83.0	8653
-16.0	144374	34.0	30840	84.0	8449
-15.0	139576	35.0	29986	85.0	8250
-14.0	134956	36.0	29157	86.0	8057
-13.0	130506	37.0	28355	87.0	7869
-12.0	126219	38.0	27577	88.0	7686
-11.0	122089	39.0	26823	89.0	7507
-10.0	118108	40.0	26092	90.0	7334
-9.0	114272	41.0	25383	91.0	7165
-8.0	110575	42.0	24696	92.0	7000
-7.0	107010	43.0	24030	93.0	6840
-6.0	103574	44.0	23384	94.0	6683
-5.0	100260	45.0	22758	95.0	6531
-4.0	97064	46.0	22150	96.0	6383
-3.0	93981	47.0	21561	97.0	6239
-2.0	91008	48.0	20989	98.0	6098
-1.0	88139	49.0	20435	99.0	5961
0.0	85371	50.0	19896	100.0	5827
1.0	82699	51.0	19374	101.0	5697
2.0	80121	52.0	18867	102.0	5570
3.0	77632	53.0	18375	103.0	5446
4.0	75230	54.0	17898	104.0	5326
5.0	72910	55.0	17434	105.0	5208
6.0	70670	56.0	16984	106.0	5094
7.0	68507	57.0	16547	107.0	4982
8.0	66418	58.0	16122	108.0	4873
9.0	64399	59.0	15710	109.0	4767
10.0	62449	60.0	15310	110.0	4663
11.0	60565	61.0	14921	111.0	4562
12.0	58745	62.0	14544	112.0	4464
13.0	56985	63.0	14177	113.0	4367
14.0	55284	64.0	13820	114.0	4274
15.0	53640	65.0	13474	115.0	4182
16.0	52051	66.0	13137	116.0	4093
17.0	50514	67.0	12810	117.0	4006
18.0	49028	68.0	12492	118.0	3921
19.0	47590	69.0	12183	119.0	3838
20.0	46200	70.0	11883	120.0	3757
21.0	44855	71.0	11591	121.0	3678
22.0	43554	72.0	11307	122.0	3601
23.0	42295	73.0	11031	123.0	3526
24.0	41077	74.0	10762	124.0	3452

FAN BLADE SETTING DIMENSIONS

Shown in the drawing below are the correct fan blade setting dimensions for proper air delivery across the outdoor coil.

Any service work requiring removal or adjustment in the fan and/or motor area will require that the dimensions below be checked and blade adjusted in or out on the motor shaft accordingly.

FIGURE 11

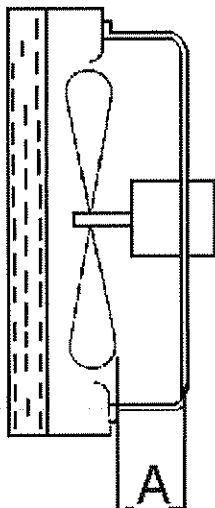

TABLE 6

Model	Dimension A
WH182 WH241	1.00

REMOVAL OF THE FAN SHROUD

1. Disconnect all power to unit.
2. Remove the screws holding both grilles, one on each side of unit, and remove grilles.
3. Remove screws (9) holding fan shroud to condenser and bottom.
4. Un-wire condenser fan motor.
5. Slide complete motor, fan blade, and shroud assembly out the left side of the unit.
6. Service motor/fan as needed.
7. Reverse steps to reinstall.

REFRIGERANT CHARGE

The correct system R-22 charge is shown on the unit rating plate. Optimum unit performance will occur with a refrigerant charge resulting in a suction line temperature (6" from compressor) as shown in Table 7.

TABLE 7 (Temperatures °F)

Model	Rated Airflow	95 OD Temperature	82 OD Temperature
WH182	650	56 - 58	63 - 65
WH241	800	57 - 59	65 - 67

The above suction line temperatures are based upon 80° F dry bulb/67° F wet bulb (50% R.H.) temperature and rated airflow across the evaporator during cooling cycle.

TABLE 8

INDOOR BLOWER PERFORMANCE CFM @ 230V

E.S.P. In H ₂ O	WH182, WH241	
	Dry	Wet
.0	1020	975
.1	960	905
.2	865	800
.3	820	735
.4	735	650
.5	615	535
.6	---	---

TABLE 9

Model	Rated CFM *	Rated ESP *	Recommended Airflow Range
WH182	650	.40	575 — 725
WH241	800	.20	700 — 950

* Rated CFM and ESP on high speed tap.

TABLE 10

MAXIMUM ESP OF OPERATION

Model	ESP
WH182 A00	.50
WH241 A04	.50
WH241 A08	.40
WH241 B00	.50
WH241 B06	.50
WH241 C00	.50
WH241 C06	.50

Values shown are for units equipped with standard throwaway filter or 1" washable filter. Derate ESP by .15 for 2" pleated filter.

TABLE 11 – PRESSURE TABLE

COOLING

Air Temperature Entering Outdoor Coil °F

Model	Return Air Temperature	Pressure	75	80	85	90	95	100	105	110	115
WH182	75 deg. DB 62 deg. WB	Low Side	77	78	80	81	83	84	86	87	89
		High Side	193	209	224	240	255	271	287	302	318
	80 deg. DB 67 deg. WB	Low Side	82	84	85	87	89	90	92	93	95
		High Side	198	214	230	246	262	278	294	310	326
	85 deg. DB 72 deg. WB	Low Side	88	90	92	94	95	97	99	100	102
		High Side	205	222	238	255	271	288	304	321	337
WH241	75 deg. DB 62 deg. WB	Low Side	75	76	77	79	80	81	83	84	86
		High Side	216	229	242	256	271	286	302	318	336
	80 deg. DB 67 deg. WB	Low Side	80	81	83	84	85	87	88	90	92
		High Side	221	235	248	263	278	293	310	327	344
	85 deg. DB 72 deg. WB	Low Side	86	88	89	90	92	93	95	97	99
		High Side	229	243	257	272	288	304	321	338	356

TABLE 12 – PRESSURE TABLE

HEATING

Air Temperature Entering Outdoor Coil °F

Model	Return Air Temperature	Pressure	0	5	10	15	17	20	25	30	35	40	45	47	50	55	60
WH182	70	Low Side	20	24	27	31	32	35	39	44	49	54	59	62	65	71	78
		High Side	178	181	184	189	191	194	201	208	216	225	235	239	249	257	270
WH241	70	Low Side	30	30	31	32	33	34	37	41	45	50	56	59	63	71	79
		High Side	158	158	159	162	164	167	175	184	195	208	223	230	241	260	281

Low Side Pressure ± 2 PSIG
 High Side Pressure ± 5 PSIG

Tables are based upon rated CFM (airflow) across the evaporator coil and should be found under section titled "Refrigerant Charge" elsewhere in manual. If there is any doubt as to correct operation charge being in the system, the charge should be removed, system evacuated, and recharged to serial plate instructions.

TABLE 13 – OPTIONAL ACCESSORIES

MODEL	DESCRIPTION	WH182-A	WH241-A	WH241-B	WH241-C
EHWH02-A05	Heater Packages	X	X		
EHWH02-A10	Heater Packages	X	X		
EHWH24-B06	Heater Packages			X	
EHWH24-CO6	Heater Packages				X
BOP-2	Blank Off Plate	X	X	X	X
BFAD-2	Barometric Fresh Air Damper	X	X	X	X
MFAD-2	Motorized Fresh Air Damper	X	X	X	X
CRV-2	Classroom Ventilator with Exhaust	X	X	X	X
EIFM-2	Economizer with Exhaust	X	X	X	X
WERV-A2A	Energy Recovery Ventilator	X	X	X	
CMH-3	Low Pressure Control (LPC)	X	X	X	X
CMH-7	Low Ambient Control (LAC)	X	X	X	
CMH-9	LAC + LPC	X	X	X	
CMH-14	Outdoor Thermostat (ODT)	X	X		
CMH-15	Start Kit (SK)	X	X		
WMCB-02A	Circuit Breaker Kit	X			
WMCB-03A	Circuit Breaker Kit		X		
WMBC-02B	Circuit Breaker Kit			X	
WMBC-01C	Pull Disconnect Kit				X

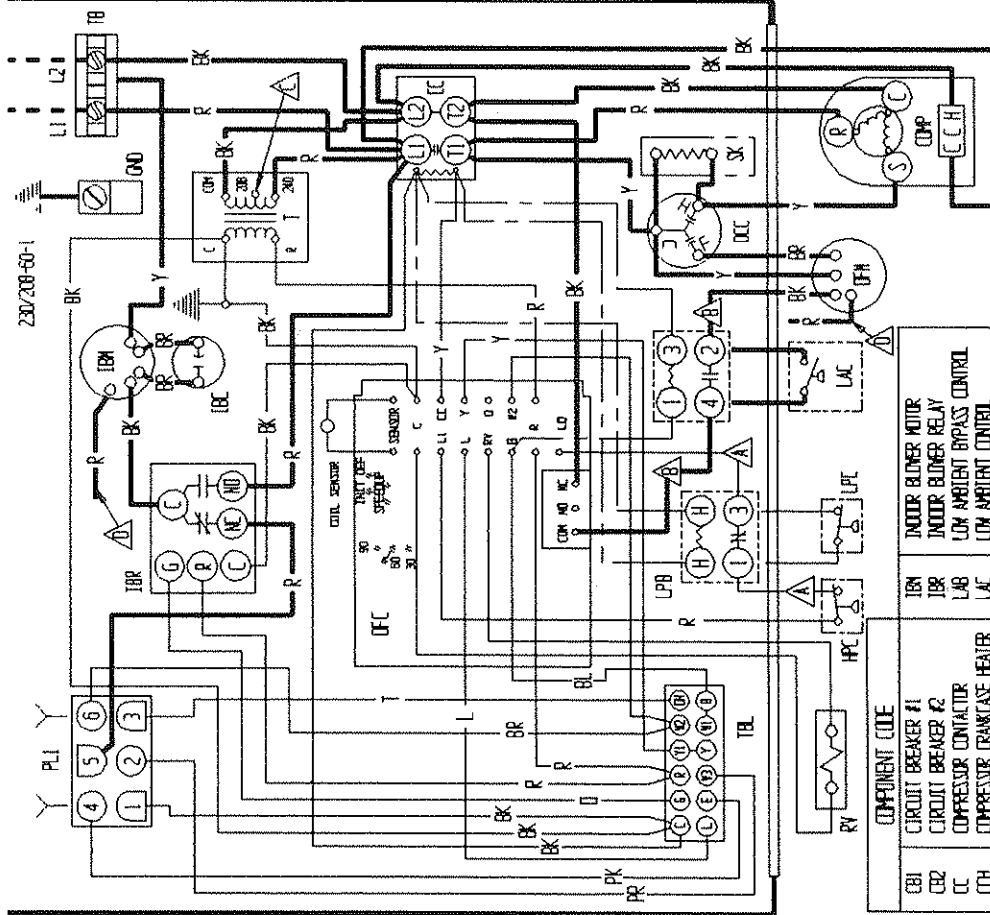
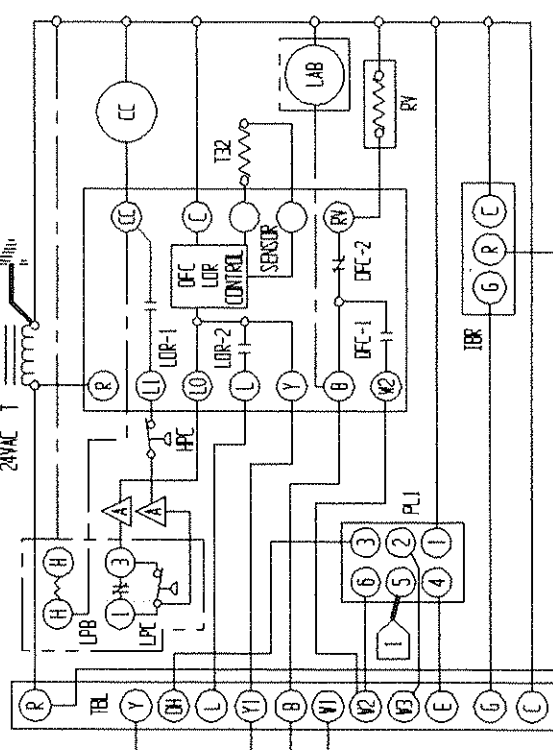
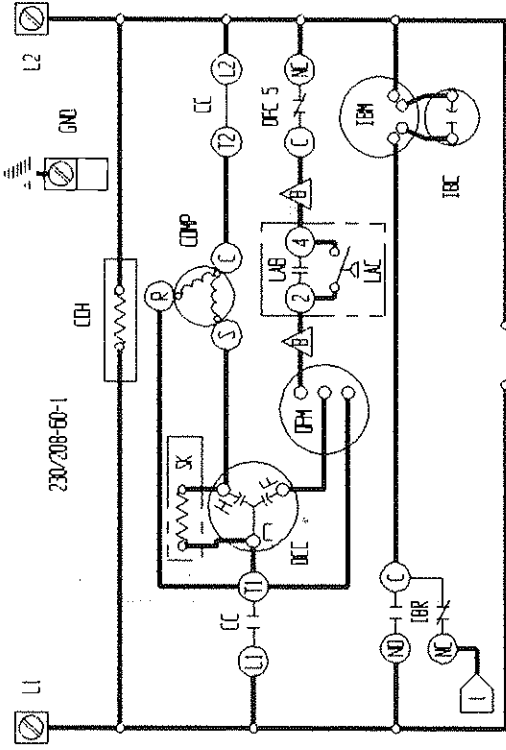

USE COPPER CONDUCTORS ONLY
SUITABLE FOR AT LEAST 75°C

COMPONENT CODE		COLOR CODE		FACTORY STD.		OPTIONAL	
IB1	INDOOR BLOWER MOTOR	BK	BLACK	Y	YELLOW		
IB2	INDOOR BLOWER RELAY	BR	BROWN	G	GREEN		
CC	CIRCUIT BREAKER #1	R	RED	R	RED		
CC2	CIRCUIT BREAKER #2	D	ORANGE	Y	YELLOW		
CC3	COMPRESSOR CONTACTOR						
CC4	COMPRESSOR CRANKCASE HEATER						
CC5	COMPRESSOR						
CC6	DUAL CAPACITOR						
CC7	DEFROST CONTROL						
CC8	EMERGENCY HEAT RELAY						
CC9	EQUIPMENT GROUND						
CC10	HEAT STRIP #1						
CC11	HEAT STRIP #2						
CC12	HEATER CONTACTOR #1						
CC13	HEATER CONTACTOR #2						
CC14	HIGH PRESSURE CONTROL						
CC15	INDOOR BLOWER CAPACITOR						
CC16	INDOOR BLOWER BYPASS CONTROL						
CC17	LOW AMBIENT CONTROL						
CC18	LOW AMBIENT BYPASS CONTROL						
CC19	LOW PRESSURE CONTROL						
CC20	LOW PRESSURE BYPASS CONTROL						
CC21	LIMIT SWITCH						
CC22	OUTDOOR FAN MOTOR						
CC23	PLUS #1						
CC24	REV. VALVE SOLINOID						
CC25	START KIT						
CC26	TRANSFORMER						
CC27	TERMINAL BLOCK						
CC28	LOW VOLTAGE TERMINAL BLOCK						
CC29	THERMAL OVERLOAD						
CC30	INDOOR BLOWER RELAY						
CC31	LOW AMBIENT CONTROL						
CC32	LOW PRESSURE CONTROL						
CC33	LIMIT SWITCH						
CC34	OUTDOOR FAN MOTOR						
CC35	PLUS #1						
CC36	REV. VALVE SOLINOID						
CC37	START KIT						
CC38	TRANSFORMER						
CC39	TERMINAL BLOCK						
CC40	LOW VOLTAGE TERMINAL BLOCK						
CC41	THERMAL OVERLOAD						
CC42	INDOOR BLOWER RELAY						
CC43	LOW AMBIENT CONTROL						
CC44	LOW PRESSURE CONTROL						
CC45	LIMIT SWITCH						
CC46	OUTDOOR FAN MOTOR						
CC47	PLUS #1						
CC48	REV. VALVE SOLINOID						
CC49	START KIT						
CC50	TRANSFORMER						
CC51	TERMINAL BLOCK						
CC52	LOW VOLTAGE TERMINAL BLOCK						
CC53	THERMAL OVERLOAD						
CC54	INDOOR BLOWER RELAY						
CC55	LOW AMBIENT CONTROL						
CC56	LOW PRESSURE CONTROL						
CC57	LIMIT SWITCH						
CC58	OUTDOOR FAN MOTOR						
CC59	PLUS #1						
CC60	REV. VALVE SOLINOID						
CC61	START KIT						
CC62	TRANSFORMER						
CC63	TERMINAL BLOCK						
CC64	LOW VOLTAGE TERMINAL BLOCK						
CC65	THERMAL OVERLOAD						
CC66	INDOOR BLOWER RELAY						
CC67	LOW AMBIENT CONTROL						
CC68	LOW PRESSURE CONTROL						
CC69	LIMIT SWITCH						
CC70	OUTDOOR FAN MOTOR						
CC71	PLUS #1						
CC72	REV. VALVE SOLINOID						
CC73	START KIT						
CC74	TRANSFORMER						
CC75	TERMINAL BLOCK						
CC76	LOW VOLTAGE TERMINAL BLOCK						
CC77	THERMAL OVERLOAD						
CC78	INDOOR BLOWER RELAY						
CC79	LOW AMBIENT CONTROL						
CC80	LOW PRESSURE CONTROL						
CC81	LIMIT SWITCH						
CC82	OUTDOOR FAN MOTOR						
CC83	PLUS #1						
CC84	REV. VALVE SOLINOID						
CC85	START KIT						
CC86	TRANSFORMER						
CC87	TERMINAL BLOCK						
CC88	LOW VOLTAGE TERMINAL BLOCK						
CC89	THERMAL OVERLOAD						
CC90	INDOOR BLOWER RELAY						
CC91	LOW AMBIENT CONTROL						
CC92	LOW PRESSURE CONTROL						
CC93	LIMIT SWITCH						
CC94	OUTDOOR FAN MOTOR						
CC95	PLUS #1						
CC96	REV. VALVE SOLINOID						
CC97	START KIT						
CC98	TRANSFORMER						
CC99	TERMINAL BLOCK						
CC100	LOW VOLTAGE TERMINAL BLOCK						
CC101	THERMAL OVERLOAD						
CC102	INDOOR BLOWER RELAY						
CC103	LOW AMBIENT CONTROL						
CC104	LOW PRESSURE CONTROL						
CC105	LIMIT SWITCH						
CC106	OUTDOOR FAN MOTOR						
CC107	PLUS #1						
CC108	REV. VALVE SOLINOID						
CC109	START KIT						
CC110	TRANSFORMER						
CC111	TERMINAL BLOCK						
CC112	LOW VOLTAGE TERMINAL BLOCK						
CC113	THERMAL OVERLOAD						
CC114	INDOOR BLOWER RELAY						
CC115	LOW AMBIENT CONTROL						
CC116	LOW PRESSURE CONTROL						
CC117	LIMIT SWITCH						
CC118	OUTDOOR FAN MOTOR						
CC119	PLUS #1						
CC120	REV. VALVE SOLINOID						
CC121	START KIT						
CC122	TRANSFORMER						
CC123	TERMINAL BLOCK						
CC124	LOW VOLTAGE TERMINAL BLOCK						
CC125	THERMAL OVERLOAD						
CC126	INDOOR BLOWER RELAY						
CC127	LOW AMBIENT CONTROL						
CC128	LOW PRESSURE CONTROL						
CC129	LIMIT SWITCH						
CC130	OUTDOOR FAN MOTOR						
CC131	PLUS #1						
CC132	REV. VALVE SOLINOID						
CC133	START KIT						
CC134	TRANSFORMER						
CC135	TERMINAL BLOCK						
CC136	LOW VOLTAGE TERMINAL BLOCK						
CC137	THERMAL OVERLOAD						
CC138	INDOOR BLOWER RELAY						
CC139	LOW AMBIENT CONTROL						
CC140	LOW PRESSURE CONTROL						
CC141	LIMIT SWITCH						
CC142	OUTDOOR FAN MOTOR						
CC143	PLUS #1						
CC144	REV. VALVE SOLINOID						
CC145	START KIT						
CC146	TRANSFORMER						
CC147	TERMINAL BLOCK						
CC148	LOW VOLTAGE TERMINAL BLOCK						
CC149	THERMAL OVERLOAD						
CC150	INDOOR BLOWER RELAY						
CC151	LOW AMBIENT CONTROL						
CC152	LOW PRESSURE CONTROL						
CC153	LIMIT SWITCH						
CC154	OUTDOOR FAN MOTOR						
CC155	PLUS #1						
CC156	REV. VALVE SOLINOID						
CC157	START KIT						
CC158	TRANSFORMER						
CC159	TERMINAL BLOCK						
CC160	LOW VOLTAGE TERMINAL BLOCK						
CC161	THERMAL OVERLOAD						
CC162	INDOOR BLOWER RELAY						
CC163	LOW AMBIENT CONTROL						
CC164	LOW PRESSURE CONTROL						
CC165	LIMIT SWITCH						
CC166	OUTDOOR FAN MOTOR						
CC167	PLUS #1						
CC168	REV. VALVE SOLINOID						
CC169	START KIT						
CC170	TRANSFORMER						
CC171	TERMINAL BLOCK						
CC172	LOW VOLTAGE TERMINAL BLOCK						
CC173	THERMAL OVERLOAD						
CC174	INDOOR BLOWER RELAY						
CC175	LOW AMBIENT CONTROL						
CC176	LOW PRESSURE CONTROL						
CC177	LIMIT SWITCH						
CC178	OUTDOOR FAN MOTOR						
CC179	PLUS #1						
CC180	REV. VALVE SOLINOID						
CC181	START KIT						
CC182	TRANSFORMER						
CC183	TERMINAL BLOCK						
CC184	LOW VOLTAGE TERMINAL BLOCK						
CC185	THERMAL OVERLOAD						
CC186	INDOOR BLOWER RELAY						
CC187	LOW AMBIENT CONTROL						
CC188	LOW PRESSURE CONTROL						
CC189	LIMIT SWITCH						
CC190	OUTDOOR FAN MOTOR						
CC191	PLUS #1						
CC192	REV. VALVE SOLINOID						
CC193	START KIT						
CC194	TRANSFORMER						
CC195	TERMINAL BLOCK						
CC196	LOW VOLTAGE TERMINAL BLOCK						
CC197	THERMAL OVERLOAD						
CC198	INDOOR BLOWER RELAY						
CC199	LOW AMBIENT CONTROL						
CC200	LOW PRESSURE CONTROL						
CC201	LIMIT SWITCH						
CC202	OUTDOOR FAN MOTOR						
CC203	PLUS #1						
CC204	REV. VALVE SOLINOID						
CC205	START KIT						
CC206	TRANSFORMER						
CC207	TERMINAL BLOCK						

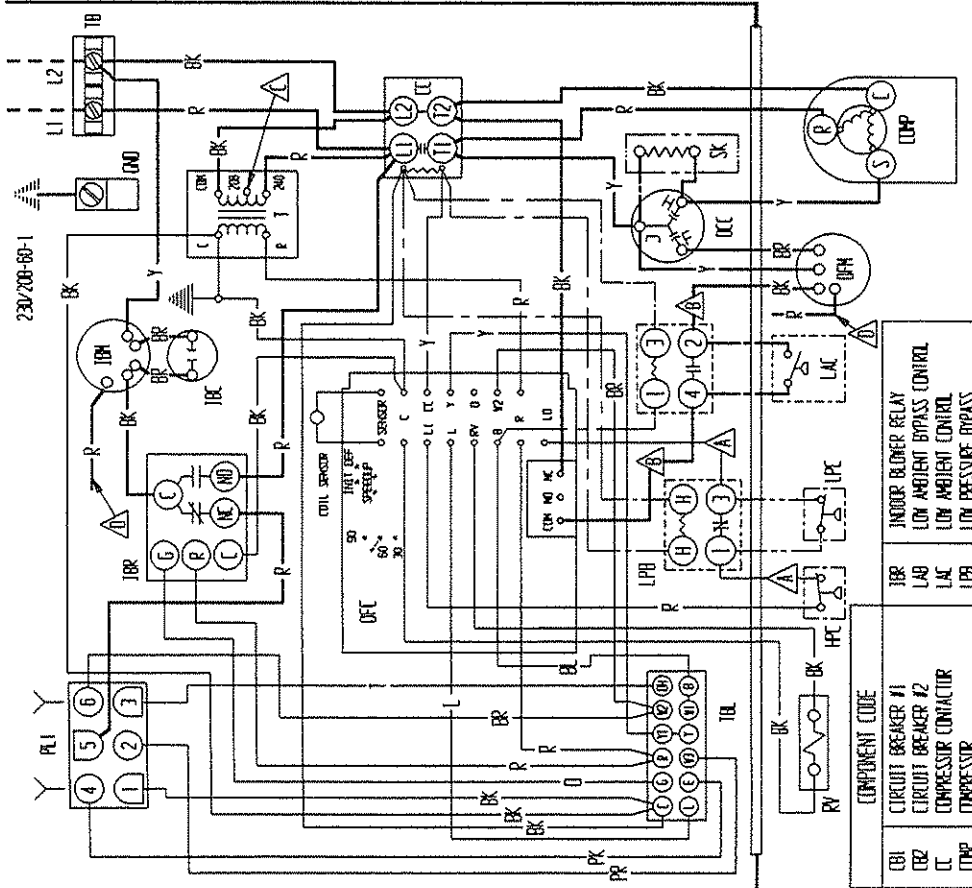
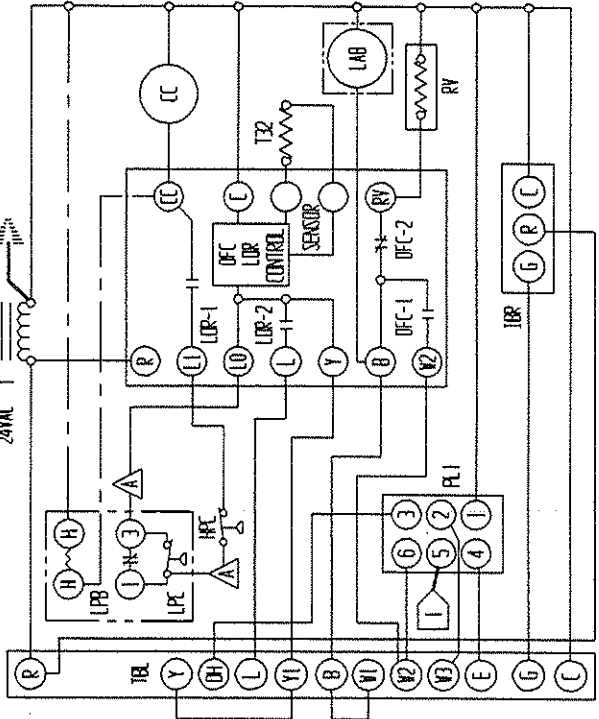
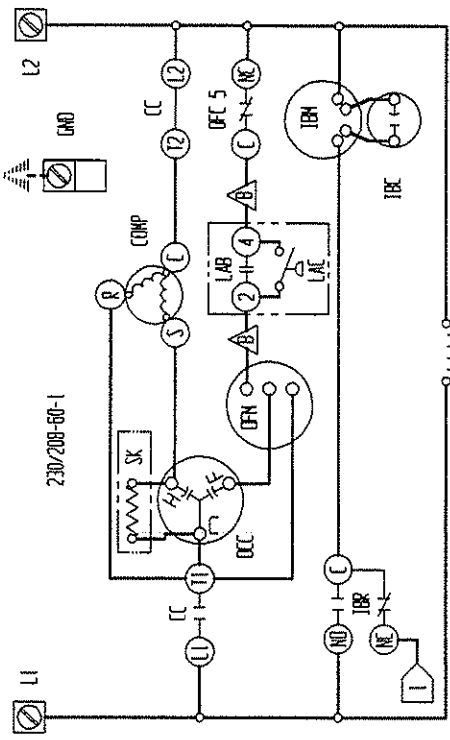

USE COPPER CONDUCTORS ONLY
SUITABLE FOR AT LEAST 75° C

<p>▲ ▲ Labeled wires connect if no options used.</p> <p>▲ ▲ Move red wire to 208V tap for 208V operation.</p> <p>▲ Red (low) black (high) where applicable.</p>	<p>Color Code</p> <table border="1"> <tr> <td>Y</td> <td>YELLOW</td> <td>V</td> <td>VIOLET</td> <td>T</td> <td>TAN</td> </tr> <tr> <td>G</td> <td>GREEN</td> <td>(PR)</td> <td>PURPLE</td> <td>PK</td> <td>PINK</td> </tr> <tr> <td>B</td> <td>BLUE</td> <td>GY</td> <td>GRAY</td> <td>L</td> <td>LAVENDER</td> </tr> <tr> <td>W</td> <td>WHITE</td> <td>(S)</td> <td>SLATE</td> <td></td> <td></td> </tr> </table>	Y	YELLOW	V	VIOLET	T	TAN	G	GREEN	(PR)	PURPLE	PK	PINK	B	BLUE	GY	GRAY	L	LAVENDER	W	WHITE	(S)	SLATE																		
Y	YELLOW	V	VIOLET	T	TAN																																				
G	GREEN	(PR)	PURPLE	PK	PINK																																				
B	BLUE	GY	GRAY	L	LAVENDER																																				
W	WHITE	(S)	SLATE																																						
<p>Factory Std.</p> <table border="1"> <tr> <td>BR</td> <td>BLACK</td> <td>Y</td> <td>YELLOW</td> </tr> <tr> <td>BR</td> <td>BROWN</td> <td>G</td> <td>GREEN</td> </tr> <tr> <td>R</td> <td>RED</td> <td>B</td> <td>BLUE</td> </tr> <tr> <td>W</td> <td>BRANCE</td> <td>W</td> <td>WHITE</td> </tr> </table>	BR	BLACK	Y	YELLOW	BR	BROWN	G	GREEN	R	RED	B	BLUE	W	BRANCE	W	WHITE	<p>Optional</p> <table border="1"> <tr> <td>IBR</td> <td>INDOOR BLOWER RELAY</td> </tr> <tr> <td>LAB</td> <td>LOW AMBIENT CONTROL</td> </tr> <tr> <td>LAC</td> <td>LOW AMBIENT BYPASS</td> </tr> <tr> <td>LPC</td> <td>LOW PRESSURE CONTROL</td> </tr> <tr> <td>LS</td> <td>LIMIT SWITCH</td> </tr> <tr> <td>OFN</td> <td>OUTDOOR FAN MOTOR</td> </tr> <tr> <td>PL1</td> <td>PLUG #1</td> </tr> <tr> <td>RV</td> <td>REV. VALVE SOLINOID</td> </tr> <tr> <td>SK</td> <td>START KIT</td> </tr> <tr> <td>T</td> <td>TRANSFORMER</td> </tr> <tr> <td>IBL</td> <td>INDOOR BLOWER BLOCK</td> </tr> <tr> <td>ICD</td> <td>INDOOR BLOWER CAPACITOR</td> </tr> </table>	IBR	INDOOR BLOWER RELAY	LAB	LOW AMBIENT CONTROL	LAC	LOW AMBIENT BYPASS	LPC	LOW PRESSURE CONTROL	LS	LIMIT SWITCH	OFN	OUTDOOR FAN MOTOR	PL1	PLUG #1	RV	REV. VALVE SOLINOID	SK	START KIT	T	TRANSFORMER	IBL	INDOOR BLOWER BLOCK	ICD	INDOOR BLOWER CAPACITOR
BR	BLACK	Y	YELLOW																																						
BR	BROWN	G	GREEN																																						
R	RED	B	BLUE																																						
W	BRANCE	W	WHITE																																						
IBR	INDOOR BLOWER RELAY																																								
LAB	LOW AMBIENT CONTROL																																								
LAC	LOW AMBIENT BYPASS																																								
LPC	LOW PRESSURE CONTROL																																								
LS	LIMIT SWITCH																																								
OFN	OUTDOOR FAN MOTOR																																								
PL1	PLUG #1																																								
RV	REV. VALVE SOLINOID																																								
SK	START KIT																																								
T	TRANSFORMER																																								
IBL	INDOOR BLOWER BLOCK																																								
ICD	INDOOR BLOWER CAPACITOR																																								

BARD MFG. CO.
4096-115 A

COMPONENT CODE	DESCRIPTION
IB1	CIRCUIT BREAKER #1
IB2	CIRCUIT BREAKER #2
CC	COMPRESSOR CONTACTOR
COMP	COMPRESSOR
CC	DUAL CAPACITOR
DFC	DEFROST CONTROL
ERR	EMERGENCY HEAT RELAY EQUIPMENT GROUND
HS1	HEAT STRIP #1
HS2	HEAT STRIP #2
HC1	HEATER CONTACTOR #1
HC2	HEATER CONTACTOR #2
HFC	HIGH PRESSURE CONTROL
IBL	INDOOR BLOWER BLOCK
ICD	INDOOR BLOWER CAPACITOR

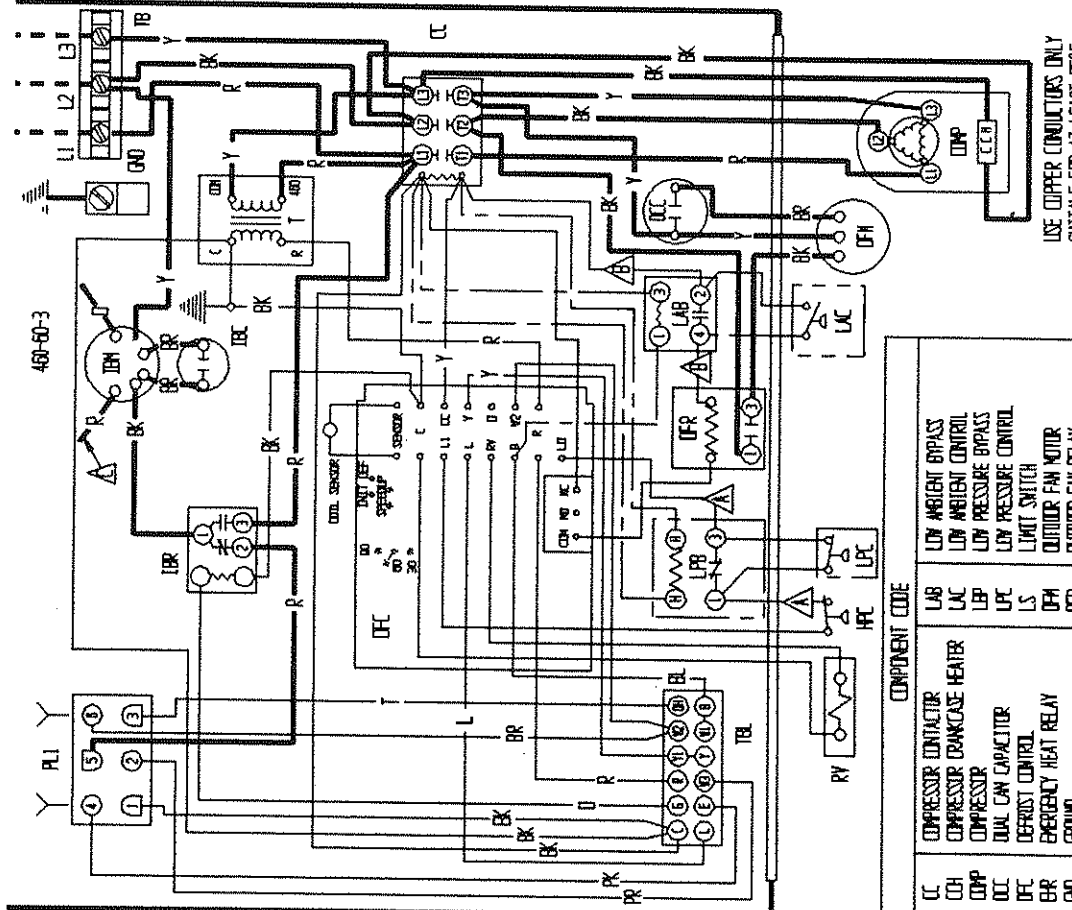
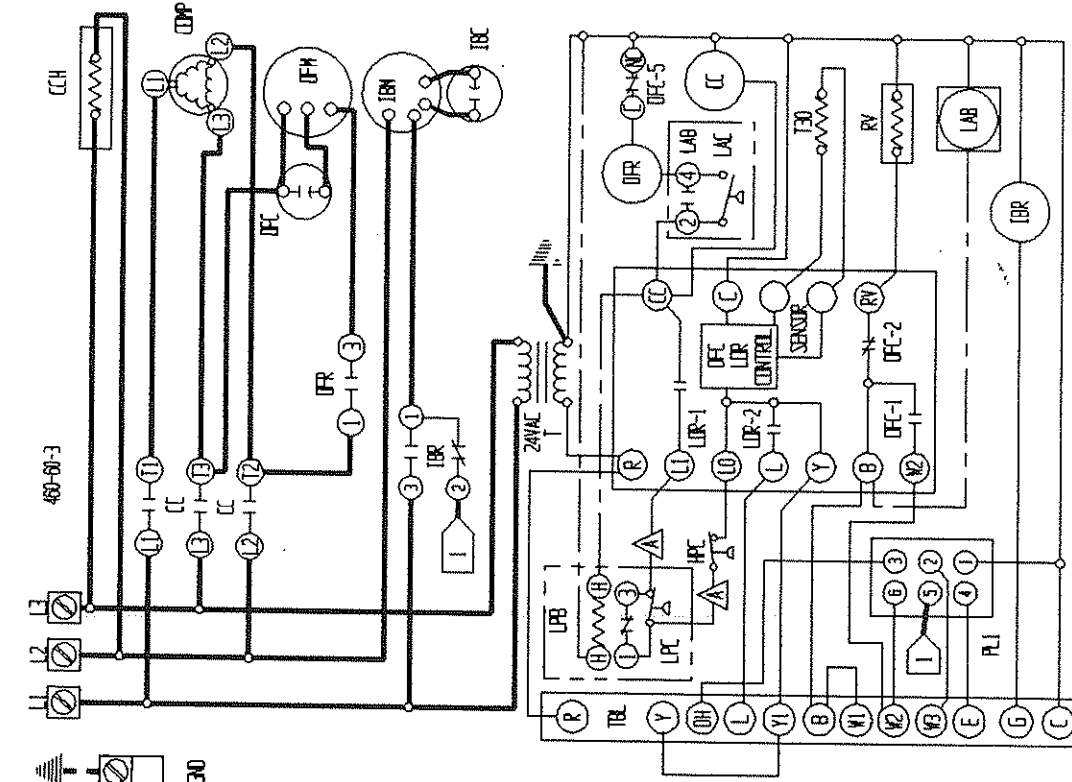

FOR LOW SPEED CONNECT BLACK AND ORANGE WIRES TOGETHER AND INSULATE. CONNECT RED WIRE TO TERMINAL 1 OF IIR.

USE COPPER CONDUCTORS ONLY SUITABLE FOR AT LEAST 75°C

BLACK	BR	BK	Y	GREEN	YELLOW	V	VIOLET	T	PINK	LAB	CO.
BROWN	R	OR	U	BLUE	GREEN	(R)	PURPLE	PK	LAVENDER	LAB	
RED	D	DR	BL	GRAY	WHITE	(S)	SLATE	L			
ORANGE			W	ACCESSORY	OPTIONAL						

COMPONENT CODE

CC	COMPARATOR	LAB	LOW AMBIENT BYPASS
CH	HEATER	LAC	LOW AMBIENT CONTROL
CP	COMPRESSOR	LP	LOW PRESSURE BYPASS
CC	DUAL CAPACITOR	LPC	LOW PRESSURE CONTROL
FC	DEFROST CONTROL	LS	LIMIT SWITCH
ER	EMERGENCY HEAT RELAY	OFM	OUTDOOR FAN MOTOR
GD	GROUND	ORF	OUTDOOR FAN RELAY
HT	HEAT STRIP #1	PLI	PULL DISCONNECT
H2	HEAT STRIP #2	PD	REV. VALVE SOL. INDOOR
H1	HEATER CONTACTOR #1	RV	START KIT
H2	HEATER CONTACTOR #2	SK	TRANSFORMER
HC	HIGH PRESSURE CONTROL	T	TERMINAL BLOCK
IBL	INDOOR BLOWER MOTOR	TB	LOW VOLTAGE TERMINAL BLOCK
IBM	INDOOR BLOWER RELAY	TEL	THERMAL CLIFF
IBR		TOO	

FACTORY STD. **FIELD** **OPTIONAL**

HIGH VOLTAGE --- --- ---

LOW VOLTAGE --- --- ---

ACCESSORY --- --- ---

BARB MFG. CO.

4096-310 D