

---

# INSTALLATION INSTRUCTIONS

---

## HIGH EFFICIENCY PACKAGED AIR CONDITIONER

**MODELS**  
**P1124A2**  
**P1130A2**  
**P1136A2**



CLIMATE CONTROL SOLUTIONS

Bard Manufacturing Company  
Bryan, Ohio 43506

*Since 1914 . . . moving ahead, just as planned.*

Manual : 2100-323A  
Supersedes: 2100-323  
File: Volume II Tab 10  
Date: 03-01-01

# Contents

<b>Getting Other Informations and Publications</b> .....	<b>1</b>
<b>General Instructions</b>	
Important .....	4
Shipping Damage .....	4
Field-Installed Heater Packages (Optional) .....	4
<b>Installation</b>	
Location .....	6
Typical Installations .....	6
Condensate Drain Trap .....	9
Air Filters .....	9
Wiring – Main Power .....	10
Wiring – 24V Low Voltage Control Circuit .....	10
Transformer Taps .....	10
Thermostats .....	10
<b>Start Up and Operation</b>	
Three Phase Scroll Compressor Start Up Information .....	11
Sequence of Operation .....	11
Start Up Notes .....	11
High Pressure Switch and Lockout Relay .....	11
<b>Service and Troubleshooting</b>	
Service Hints .....	12
Pressure Service Ports .....	12
Refrigerant Charge .....	12
Fan Blade Settings .....	12
Suction and Discharge Tube Brazing .....	12
Pressure Table .....	13
Wiring Diagrams .....	14 - 17

## Figures

Figure 1	Prefabricated Flood Curb Specifications .....	5
Figure 2	Field Fabricated Curbing .....	5
Figure 3	Elevated Mounting Platforms .....	7
Figure 4	Airflow and Service Access Clearances .....	7
Figure 5	Roof Top Application .....	8
Figure 6	Slab Mounting at Ground Level .....	8
Figure 7	Condensate Drain Trap .....	9
Figure 8	Low Voltage Wiring .....	10
Figure 9	Fan Blade Setting Dimensions .....	12
Figure 10	Brazing Diagram .....	13

## Tables

Table 1	Electrical Data .....	2
Table 2	Optional Field Installed Heater Packages .....	2
Table 3	Optional Field Installed Heater Table .....	3
Table 4	Rated CFM and Rated ESP .....	6
Table 5	Air Filter Area and Size .....	9
Table 6	Thermostat Wire Size .....	10
Table 7	Wall Thermostat and Subbase Combinations .....	10
Table 8	Refrigerant Charge .....	12
Table 9	Pressure Table .....	13

# Getting Other Information and Publications

---

These publications can help you install the air conditioner or heat pump. You can usually find these at your local library or purchase them directly from the publisher. Be sure to consult current edition of each standard.

National Electrical Code ..... ANSI/NFPA 70

Standard for the Installation ..... ANSI/NFPA 90A  
of Air Conditioning and  
Ventilating Systems

Standard for Warm Air ..... ANSI/NFPA 90B  
Heating and Air  
Conditioning Systems

Load Calculation for ..... ACCA Manual J  
Residential Winter and  
Summer Air Conditioning

Duct Design for Residential ..... ACCA Manual D  
Winter and Summer Air  
Conditioning and Equipment Selection

## FOR MORE INFORMATION, CONTACT THESE PUBLISHERS:

**ACCA** Air Conditioning Contractors of America  
1712 New Hampshire Ave. N.W.  
Washington, DC 20009  
Telephone: (202) 483-9370  
Fax: (202) 234-4721

**ANSI** American National Standards Institute  
11 West Street, 13th Floor  
New York, NY 10036  
Telephone: (212) 642-4900  
Fax: (212) 302-1286

**ASHRAE** American Society of Heating Refrigerating,  
and Air Conditioning Engineers, Inc.  
1791 Tullie Circle, N.E.  
Atlanta, GA 30329-2305  
Telephone: (404) 636-8400  
Fax: (404) 321-5478

**NFPA** National Fire Protection Association  
Batterymarch Park  
P.O. Box 9101  
Quincy, MA 02269-9901  
Telephone: (800) 344-3555  
Fax: (617) 984-7057

**TABLE 1  
ELECTRICAL DATA**

Model	Rated Volts & Phases	③ HZ	Operating Voltage Range	Maximum Unit Amps	① Maximum External Fuses or Ckt. Brk.	Minimum Circuit Ampacity	② Field Power Wiring	② Ground Wire Size
					Ckt. A	Ckt. A	Ckt. A	Ckt. A
P1124A2	230/208-1	60	197 - 253	12.9	25	17	10	10
P1130A2	230/208-1	60	197 - 253	17.6	30	21	10	10
P1136A2	230/208-1	60	197 - 253	19.4	40	25	8	10
P1136A1-B	230/208-3	60	197 - 253	14.8	25	18	10	10
P1136A1-C	460	60	414 - 506	7.1	15	12	14	14

① Maximum time delay fuse or HACR type circuit breaker.

② 75 degree C cooper wire size, basic unit only.

③ 50 HZ equipment not UL listed.

**TABLE 2  
OPTIONAL FIELD INSTALLED HEATER PACKAGES  
ONLY TO BE USED WITH THE AIR CONDITIONING MODEL INDICATED**

Heater Package Model No.	Volts and Phase	P1124A2	P1130A2	P1136A2	P1136A1-B	P1136A1-C
EH3PB-A05	240/1	S	S	S	A	A
EH3PB-A08		S	S	S	A	A
EH3PB-A10		S	S	S	A	A
EH3PB-A15		S	S	S	A	A
EH3PB-B09	240/3	A	A	A	S	A
EH3PB-B15		A	A	A	S	A
EH3PB-C09	460/3		A	A	A	S
EH3PB-C15			A	A	A	S

S - Standard application - Heater volts and phase same as basic unit

A - Alternate application - Heater volts and phase different from basic unit

**TABLE 3  
OPTIONAL FIELD-INSTALLED ELECTRIC HEATER TABLE**

Heater Pkg. Model No.	Unit Volts Phase	Htr. KW & Capacity @ 240V (or 480V if applicable)		Htr. KW & Capacity @ 208 Volts		@ 240V or 480V as applicable Htr. Amps	Heater Internal Fuses	Circuit B				
		KW	BTUH	KW	BTUH			No. Field Ckts.	Minimum Circuit Ampacity	① Maximum Overcurrent Protection	② Field Power Wiring	③ Ground Wire Size
EH3PB-A05	240/208-1	5	17,100	3.75	12,800	20.8		1	28	30	10	10
EH3PB-A08	240/208-1	8	27,300	6.0	20,500	33.3		1	42	45	8	10
EH3PB-A10	240/208-1	10	34,100	7.5	26,000	41.7		1	53	60	8	10
EH3PB-A15	240/208-1	15	51,200	11.25	38,400	62.5	30/60	1	79	80	4	8
EH3PB-B09	240/208-3	9	30,700	6.75	23,000	21.7		1	28	30	10	10
EH3PB-B15	240/208-3	15	51,200	11.25	38,400	36.2		1	46	50	8	10
EH3PB-C09	460/3	9	30,700	--	--	10.8		1	14	15	14	14
EH3PB-C15	460/3	15	51,200	--	--	19.0		1	23	25	10	10

- ① Time delay fuses or "HACR Type" circuit breakers must be used for 60 and smaller sizes. Standard fuses or circuit breakers are suitable for sizes 70 and larger.
- ② Based on wire suitable for 75° C. Other wiring materials must be rated for marked "Minimum Circuit Ampacity" or greater.
- ③ Based upon Table 250-95 of N.E.C. 1993. See electrical data for basic heat pump for Circuit A wiring specification requirements.

**IMPORTANT:** While this electrical data is presented as a guide, it is important to electrically connect properly size fuses and conductor wires in accordance with the National Electrical Code and all existing local codes.

# GENERAL INSTRUCTIONS

---

## IMPORTANT

The equipment covered in this manual is to be installed by trained, experienced service and installation technicians. All duct work, supply and return ducts, must be properly sized for the design air flow requirement of the equipment. ACCA is an excellent guide to proper sizing. All duct work or portions thereof not in the conditioned space should be properly insulated in order to both conserve energy and prevent condensation or moisture damage.

## SHIPPING DAMAGE

Upon receipt of equipment, the carton should be checked for external signs of shipping damage. If damage is found, the receiving party must contact the last carrier immediately, preferably in writing, requesting inspection by the carrier's agent.

## GENERAL

The refrigerant system is completely assembled and charged. All internal wiring is complete.

The unit is designed for use with or without duct work. Flanges are provided for attaching the supply and return ducts.

These instructions explain the recommended method to install the air cooled self-contained unit and the electrical wiring connections to the unit.

These instructions and any instructions packaged with any separate equipment required to make up the entire air conditioning system should be carefully read before beginning the installation. Note particularly "Starting Procedure" and any tags and/or labels attached to the equipment.

While these instructions are intended as a general recommended guide, they do not supersede any national and/or local codes in any way. Authorities having jurisdiction should be consulted before the installation is made.

## FIELD INSTALLED HEATER PACKAGES (OPTIONAL)

These packaged air conditioners are manufactured without supplementary electric heaters. Supplementary heaters EH3PB series (to fit P1124A2, P1130A2, and P1136A2) are available for simple, fast, field installation.

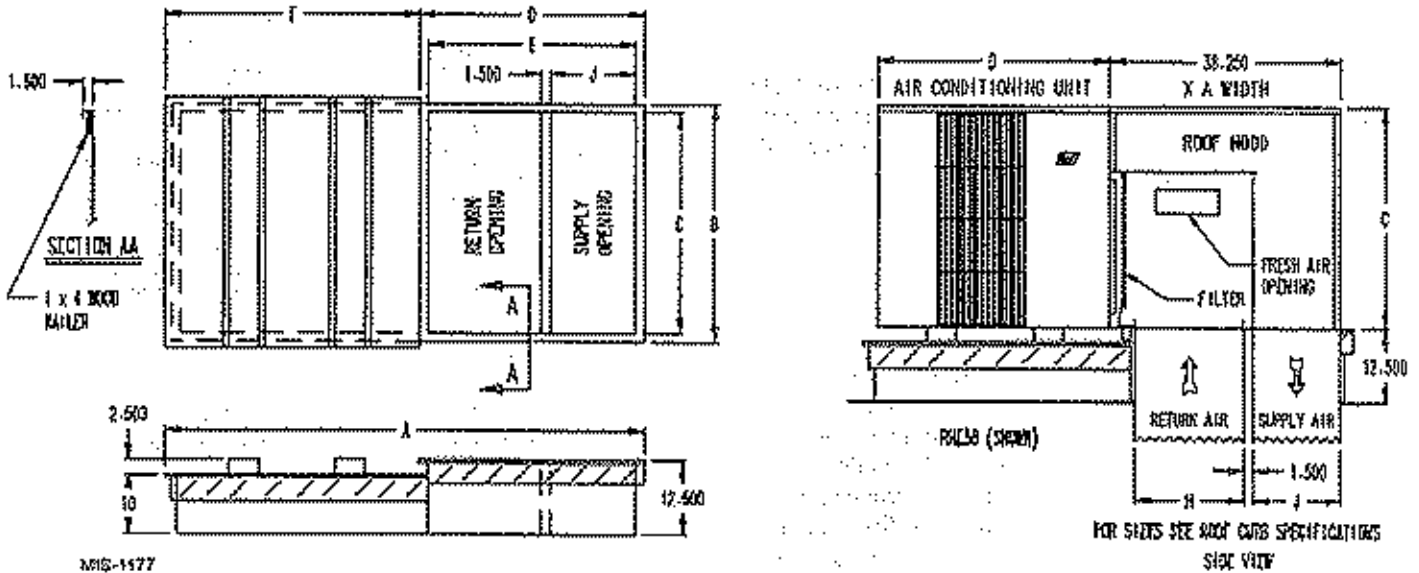
A separate field power circuit is required for the supplementary heaters.

*IMPORTANT: Refer to Table 4 when designing duct work for maximum available static pressure with heater installed.*

Refer to the electrical data shown on pages 2 and 3 for proper application information on all available heater combinations and what units they can be used with. It also shows the applicable circuit capacities, fuse size, and wire size for each heater combination.

Refer to the installation instructions packed with the heater for details on how to insert it into the basic unit.

**FIGURE 1  
 PREFABRICATED ROOF CURB SPECIFICATIONS  
 HEAVY GAUGE GALVANIZED WITH WOOD NAILING STRIP, WELDED/LEAKPROOF  
 ONE PIECE CONSTRUCTION - READY TO INSTALL**



MIS-1177

**CURB AND ROOF DETAILS**

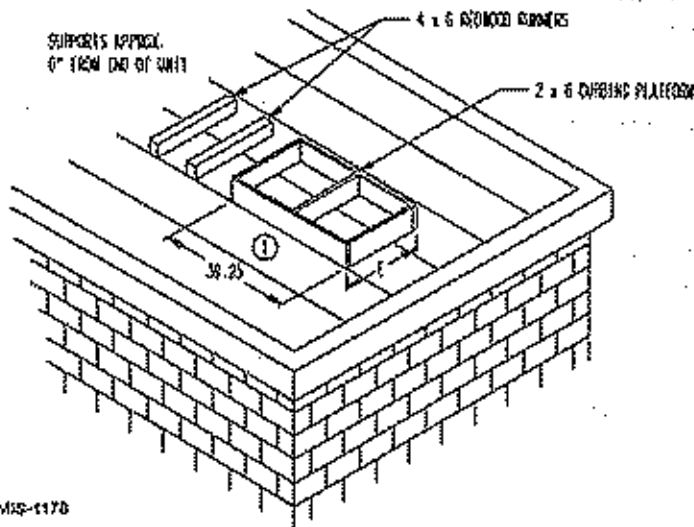
Roof Curb	A	B	C*	D	E	F	J*	H*	Roof Hood Model	Air Conditioning Units
9042-003	50-3/8	40-1/4	37-1/4	38-3/8	35-3/8	42	14-3/4	19-1/8	RHE36	P1124A2, P1130A2, P1136A2

\*Duct Sizing Information

Return Air Dimension "C" is length  
 Return Air Dimension "H" is width

Supply Air Dimension "C" is length  
 Supply Air Dimension "J" is width

**FIGURE 2  
 FIELD FABRICATED CURBING**



MIS-1178

Roof Hood Model	Unit Model	E
RHE36	P1124A2 P1130A2 P1136A2	41

① A SEPARATE METAL FLASHING SHOULD BE INSTALLED AROUND ROOF CURBING. CAULK & SEAL ALL JOINTS & WEATHERPROOF.

# INSTALLATION

## LOCATION

### GENERAL

The unit must be located outside, or in a well ventilated area. It must not be in the space being heated or cooled. A sound absorbing material should be considered if the unit is to be installed in such a position or location that might cause transmission of sound or vibration to the living area or adjacent buildings.

### SLAB MOUNTING

In areas where winter temperatures *DO NOT* go below 32° F for periods over twelve hours, the unit may be slab mounted at grade level. When installing unit at grade level, install on a concrete slab at least four inches above finished grade level. Slab should have a slope tolerance away from the building structure of at least 1/4 inch per foot, while being level from side to side. Place slab in a location where runoff water from higher ground will not collect around unit. See Figure 3.

A minimum of 18 inches should be provided between the coil inlet and any building surfaces. Provide at least four feet between coil outlet and any building wall, fences or other vertical structures. Provide a minimum of three feet clearance on the service access side of the unit. See Figure 4

### ROOF MOUNTING

When a unit is installed in areas where low ambient temperatures or strong winter winds exist, it should be placed for prevailing winter winds are not in direct line with the outdoor coil. If this is not possible, a wind barrier should be constructed. Place barrier 24 inches from the coil inlet side of the unit and in the direction of prevailing winds. Size barrier at least the same height and width as the unit. This may be necessary on ground level installations, also. See Figure 5.

### WINTER INSTALLATION BELOW 32°F

In areas where winter conditions go below 32°F for extended periods, the unit must be elevated above the mounting surface to prevent snowfall or defrost ice accumulation from interfering with the operation of the unit. A minimum of twelve inch elevation is recommended, while greater elevation may be required for areas of high snow accumulation. Poured concrete, steel framework, brick, cement block, etc., can be utilized to construct a suitable raised mounting platform. See Figure 6.

TABLE 4  
RATED CFM AND  
EXTERNAL STATIC PRESSURE (ESP)  
WET COIL (COOLING)

Model	Rated CFM	Rated ESP	Recommended Air Flow Range
P1124A2	800	.20	720 - 880 CFM
P1130A2	1150	.35	1020 - 1275 CFM
P1136A2	1275	.30	1150 - 1400 CFM

### DUCT WORK

Refer to Table 4 when designing duct work for maximum static pressure available with the specific model and heater package being installed.

### TYPICAL INSTALLATIONS

- 1. ROOF MOUNTED** - The unit is mounted on a sturdy base on the roof of the building. Return air to the unit is brought through a single return grille (grilles with built-in filters are best since they enable easy access for filter changing). Return air ducts are attached to the lower section of the front panel. Supply air is brought from the unit to attic duct work or to a furred down hall. Supply air duct is attached to the top of the front panel.

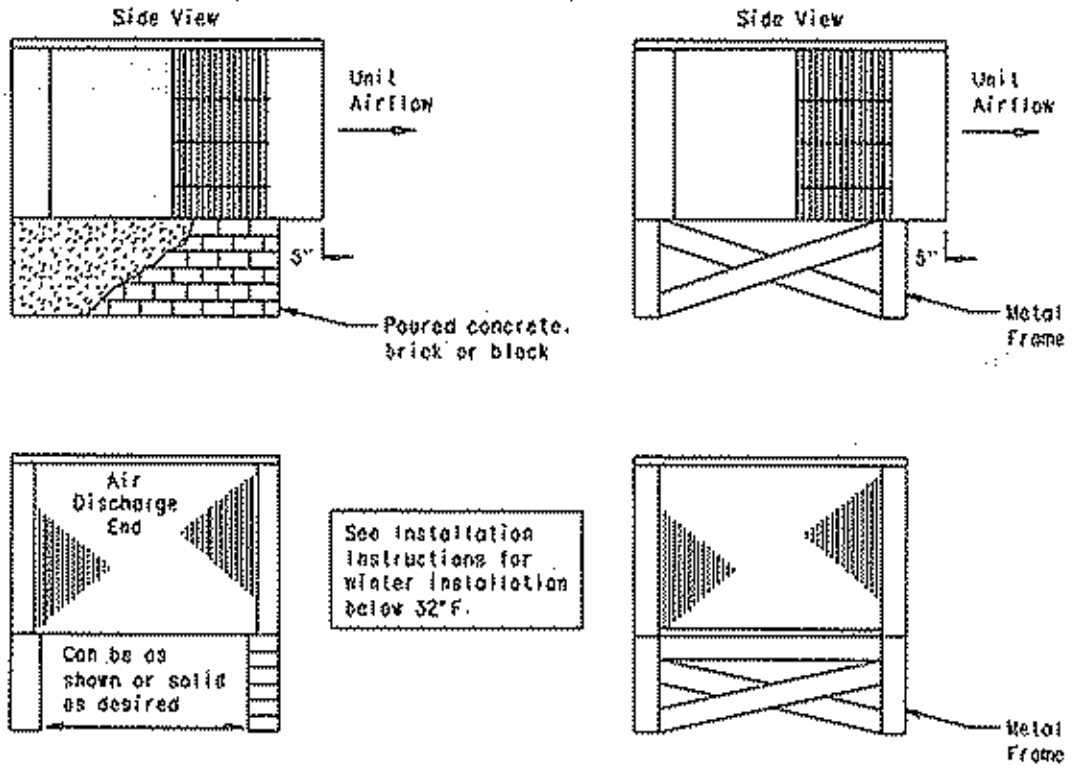
*CAUTION: All outdoor duct work must be thoroughly insulated and weatherproofed. All attic duct work must be thoroughly insulated. Two inch thick insulation with suitable vapor barrier is recommended for both outdoor and attic runs.*

In roof top installation, as in all installations, the unit must be level from side to side. However, the unit should have a pitch along the length to assure complete external drainage of precipitation.

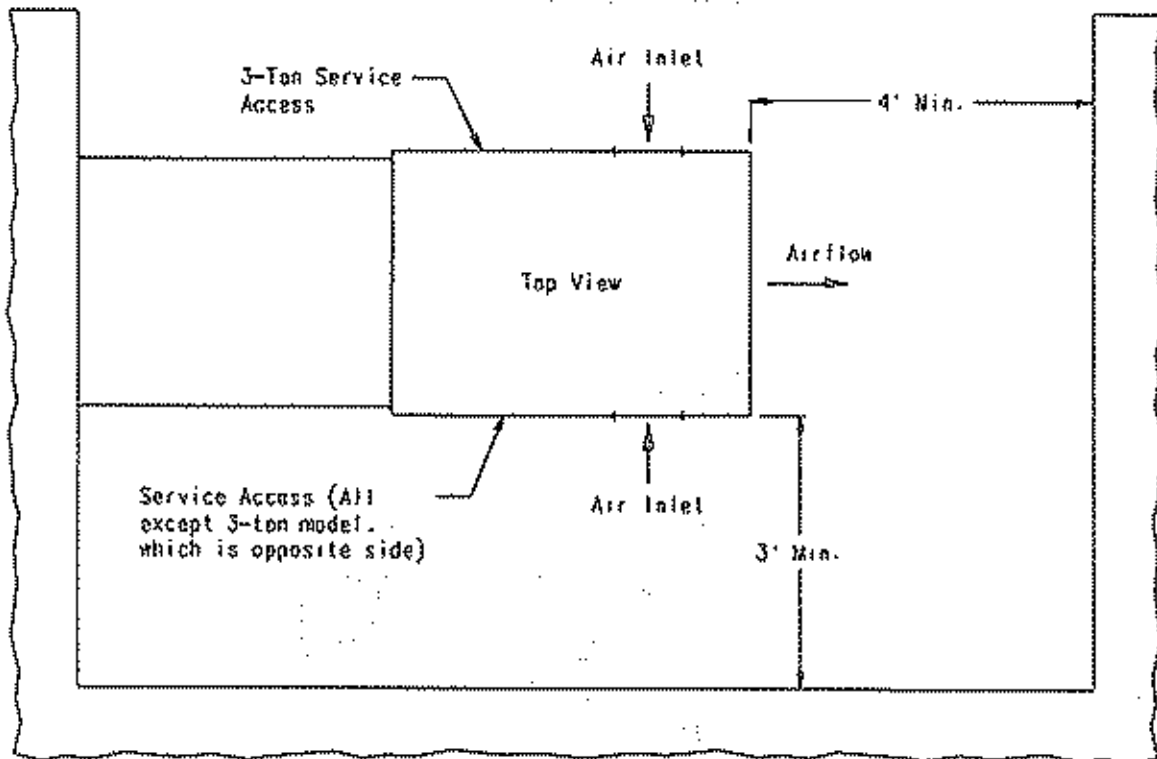
- 2. CRAWL SPACE** - Duct work installed in crawl space must be well insulated and provided with a vapor barrier. In addition, the crawl space must be thoroughly ventilated and provided with a good vapor barrier as a ground cover. It is most desirable to install the unit outdoors rather than inside the crawl space, so that it will be readily accessible for service.
- 3. SLAB MOUNTED AT GROUND LEVEL** - This type installation is ideal for homes with a slab floor construction where a roof mounted unit is not desired. The supply and return duct work can be run through a furred closet space.



**FIGURE 3  
ELEVATED MOUNTING PLATFORMS**

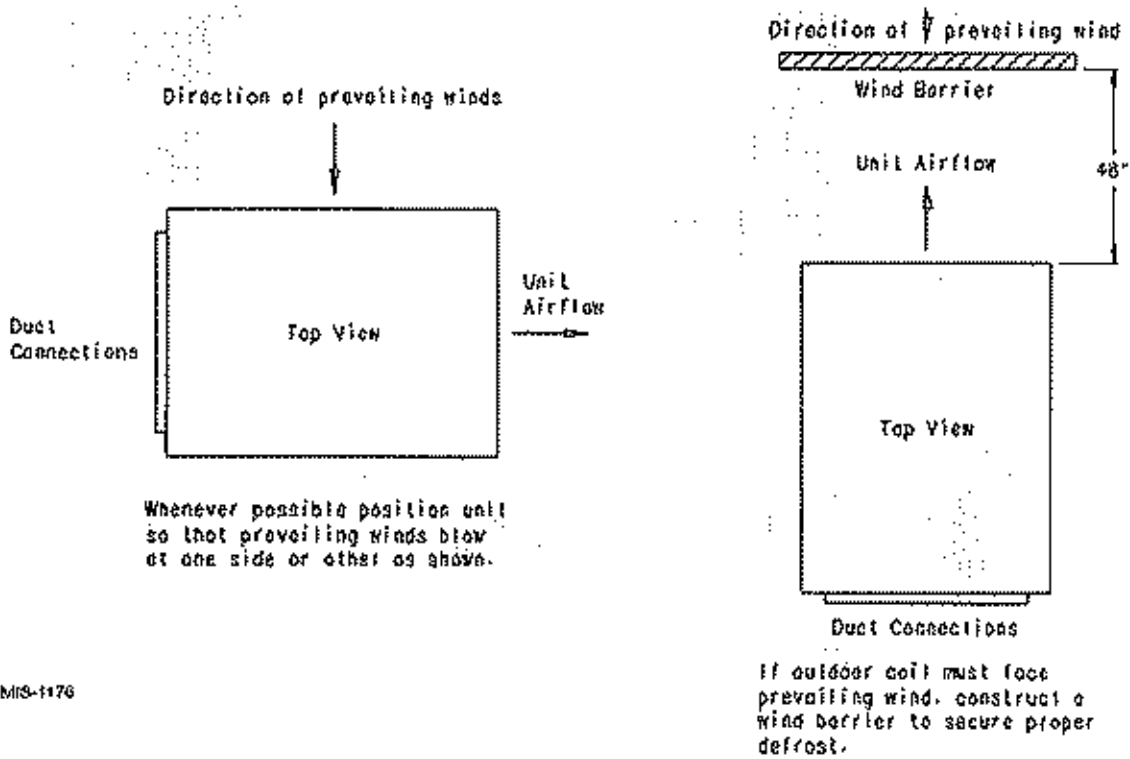


**FIGURE 4  
AIRFLOW and SERVICE ACCESS CLEARANCES**



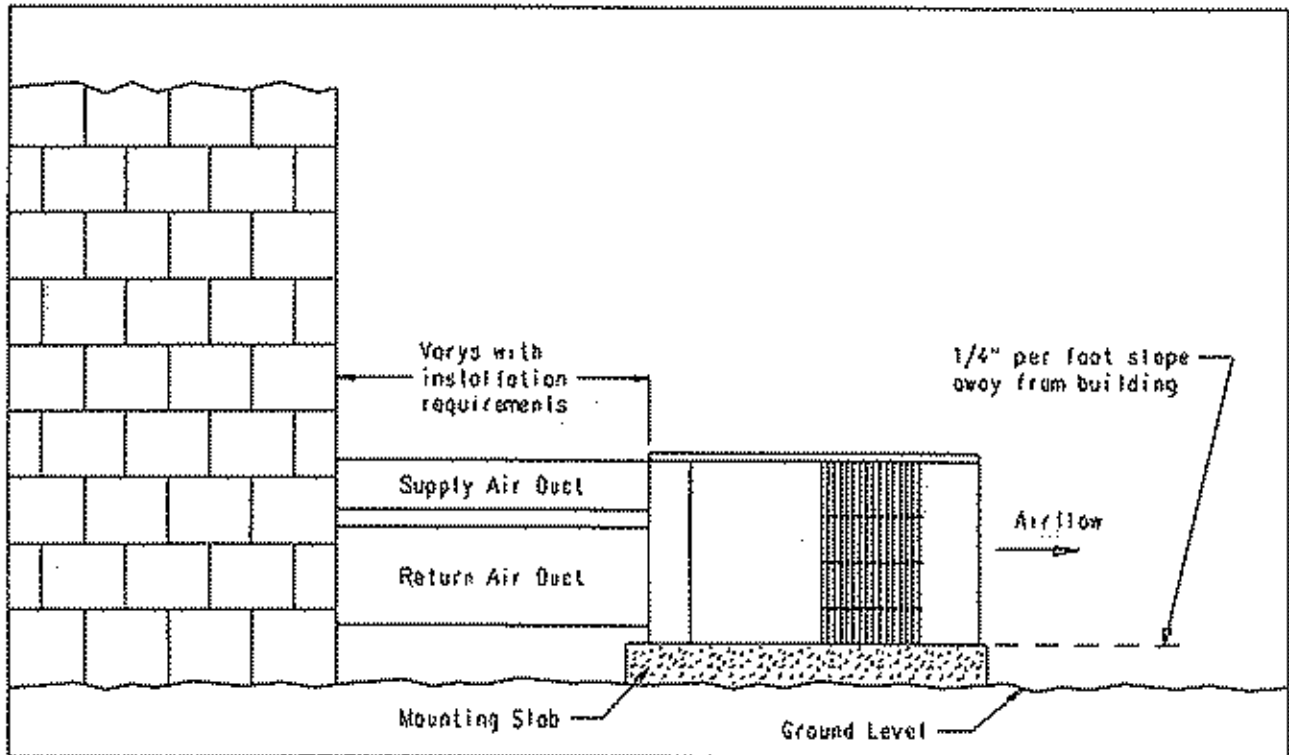
MIS-1105

**FIGURE 5**  
**ROOF TOP APPLICATION**  
 (May also be required for ground level installations.)



MIS-1176

**FIGURE 6**  
**SLAB MOUNTING AT GROUND LEVEL**  
 (Above 32° F Outside Temperature)



MIS-1184

4. **THROUGH THE WALL** -- This type installation requires a suitable framework to be fabricated capable of withstanding the unit weight. Normally the unit will be insulated so as to minimize supply and return duct work.
5. **OTHER INSTALLATIONS** -- Many other installations are possible with the packaged air conditioner. No matter what the installation, always consider the following facts:
- Insure that the discharge air is not obstructed in any way so as to cause operation difficulties.
  - The indoor coil drain pan is equipped with a coupling that must be piped through a condensate drain trap to a suitable drain.
  - Always mount the unit in such a position that it may be easily reached for servicing and maintenance.
  - Insure that the unit is clear so that proper air flow over the outdoor coil will be maintained.

If this unit is operated in cooling below a 65° outdoor ambient temperature, the installation of low ambient controls (CMA-6) to unit is required.

### CONDENSATE DRAIN TRAP

It is very important to provide a trap in the condensate drain line to allow a positive liquid seal in the line and assure correct drainage from the coil condensate pan.

Install condensate drain trap shown in Figure 7. Use drain connection size or larger. Do not operate unit without trap. Unit must be level or slightly inclined toward drain. With a trap installed on a unit located in

an unconditioned area, water in the trap may freeze. It is recommended that the trap material be of a type that will allow for expansion of water when it freezes.

### AIR FILTERS

Air filters for the return air side of the system are not provided as part of these models, and must be field supplied and installed as part of the final installation.

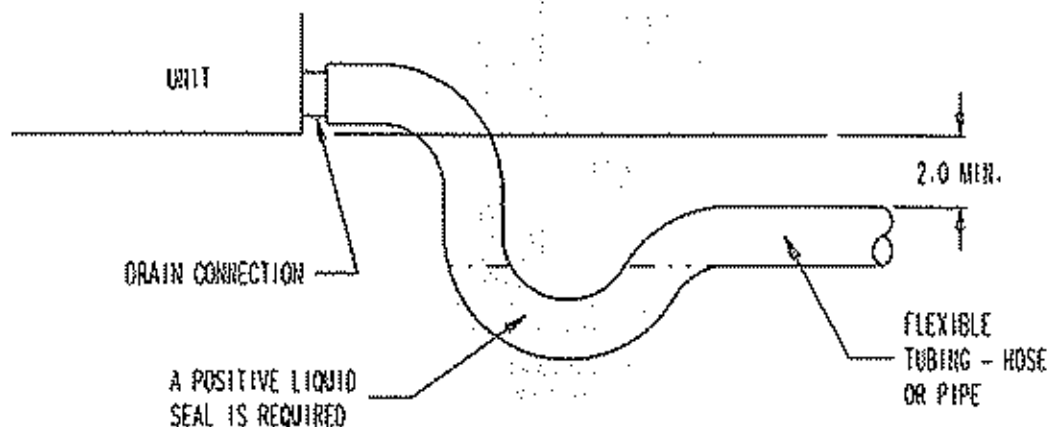
Prior thought should be given to return air location and placement of the air filter(s). The air filter(s) must be of adequate size and readily accessible to the operator of the equipment. Filters must be adequate in size and properly maintained for proper operation. If this is not done, excessive energy use, poor performance, and multiple service problems will result. *It is impossible to oversize air filters.* Generous sizing will result in cleaner air and coils as well as lower operating costs and extend the time between required changes. Table 5 shows minimum filter areas and recommended filter sizes. Actual filter sizes can vary with the installation due to single or multiple returns utilizing a filter/grille arrangement or being placed immediately ahead of the indoor coil face in the return air duct.

TABLE 5

Model	Minimum Filter Areas	Recommended Size
P1124A2 P1130A2 P1136A2	462 square inches (3.21 square feet)	15 x 30-5/8 x 1

*NOTE: If roof hood accessory is to be used, information on air filters may be found under that heading in this manual. Air filters are supplied as part of that package.*

FIGURE 7  
CONDENSATE DRAIN TRAP



MIS-136

## WIRING -- MAIN POWER

Refer to the unit rating plate for wire sizing information and maximum fuse size. Each outdoor unit is marked with a "Minimum Circuit Ampacity". This means that the field wiring used must be sized to carry that amount of current. If field installed heaters are added to the basic unit, a second separate power supply circuit will be required. The heater rating plate located adjacent to the basic unit rating plate will show the appropriate circuit ampacity fuse size, etc. (Also see "Electrical Data" on pages 2 and 3.) *All models are suitable for connection with copper wire only.* These instructions must be adhered to. Refer to the National Electrical Code for complete current carrying capacity data on the various insulation grades of wiring material.

The electrical specifications on page 2 and 3 lists fuse and wire sizes (75°F copper) for all models including the most commonly used heater sizes.

The unit rating plate lists a "Maximum Time Delay Fuse" or "HACR" type circuit breaker that is to be used with the equipment. The correct size must be used for proper circuit protection and also to assure that there will be no nuisance tripping due to the momentary high starting current of the compressor.

## WIRING -- 24V LOW VOLTAGE CONTROL CIRCUIT

Five (5) wires should be run from thermostat subbase to the 24V terminal board in the unit. A five conductor, 18 gauge copper, color-coded thermostat cable is recommended. The connection points are shown in Figure 8.

## THERMOSTATS

See specific wiring information for the different models, heater KWs, and voltages on pages 14 through 18.

FIGURE 8 -- LOW VOLTAGE WIRING

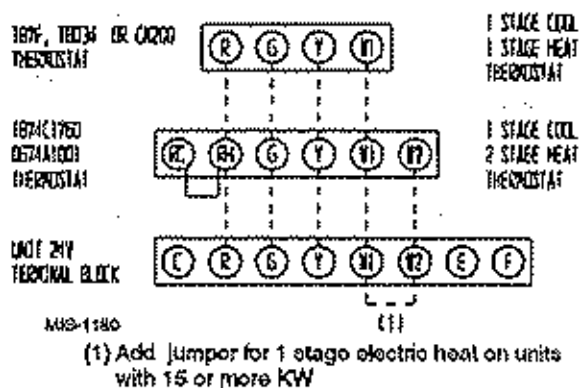


TABLE 6 -- THERMOSTAT WIRE SIZE

Transformer VA	FLA	Wire Gauge	Maximum Distance In Feet
55	2.3	20	45
		18	60
		16	100
		14	160
		12	250

## TRANSFORMER TAPS

230/208V, 1 phase and 3 phase equipment employ dual primary voltage transformers. All equipment leaves the factory wired on 240V tap. For 208V operation, reconnect from 240V to 208V tap. The acceptable operating voltage range for the 240 and 208V taps are:

TAP	RANGE
240	253 - 216
208	220 - 187

**NOTE:** The voltage should be measured at the field power connection point in the unit and while the unit is operating at full load (maximum amperage operating condition).

TABLE 7  
WALL THERMOSTAT and SUBBASE COMBINATIONS

Thermostat	Subbase	Predominant Feature
8403-019 (T874C1780)	① 8404-012 (Q674A1001)	1 stage cool, 2 stage heat System: heat-auto-cool Fan: on-auto
8403-002 (T87F3111)	① 8403-003 (Q539A1220)	1 stage heat, 1 stage cool System: heat-off-cool Fan: on-auto
8403-009 (1F56-318)	.....	1 stage heat, 1 stage cool System: heat-off-cool Fan: on-auto

- ① No automatic changeover position -- must be manually placed in heat or cool. Reversing valve remains energized at all times system switch is in heat position (except during defrost cycle). No pressure equalization noise when thermostat is satisfied on either heating or cooling.
- ② Allows thermostat to control both heating and cooling operation when set in "AUTO" position. Reversing valve de-energizes at end of each "ON" heating cycle.

**IMPORTANT NOTE:** Only the thermostat and subbase combinations as shown above will work with this equipment. The thermostat and subbase **MUST** be matched, and correct operation can be assured only by proper selection and application of these parts.

## THREE PHASE SCROLL COMPRESSOR START UP INFORMATION

Scroll compressors, like several other types of compressors, will only compress in one rotational direction. Direction of rotation is not an issue with single phase compressors since they will always start and run in the proper direction.

However, three phase compressors will rotate in either direction depending upon phasing of the power. Since there is a 50-50 chance of connecting power in such a way as to cause rotation in the reverse direction, verification of proper rotation must be made.

Verification of proper rotation direction is made by observing that suction pressure drops and discharge pressure rises when the compressor is energized. Reverse rotation also results in an elevated sound level over that with correct rotation, as well as, substantially reduced current draw compared to tabulated values.

*Verification of proper rotation must be made at the time the equipment is put into service. If improper rotation is corrected at this time there will be no negative impact on the durability of the compressor. However, reverse operation for over one hour may have a negative impact on the bearing due to oil pump out.*

*NOTE: If compressor is allowed to run in reverse rotation for several minutes the compressor's internal protector will trip.*

All three phase ZR\*3 compressors are wired identically internally. As a result, once the correct phasing is determined for a specific system or installation, connecting properly phased power leads to the same Fusite terminals should maintain proper rotation direction.

*The direction of rotation of the motor may be changed by reversing any two line connections to the unit.*

## SEQUENCE OF OPERATION

**COOLING** – Circuit R-Y makes at thermostat pulling in compressor contactor starting the compressor and outdoor motor. The G (indoor motor) circuit is automatically completed on any call for cooling operation, or can be energized by manual fan switch on subbase for constant air circulation.

**HEATING** – A circuit R-W1 is completed on each heating cycle energizing electric heat if so equipped.

## START UP NOTES

For improved start up performance, wash the indoor coil with dishwasher detergent.

## HIGH PRESSURE SWITCH AND LOCKOUT RELAY (ALL MODELS EXCEPT P1136A1-B AND P1136A1-C)

The air conditioners are equipped with an auto reset high pressure switch and lockout relay. The lockout relay may be reset by turning the thermostat to off or satisfying the thermostat.

# SERVICE AND TROUBLESHOOTING

## SERVICE HINTS

1. Caution homeowner to maintain clean air filters at all times. Also, not to needlessly close off supply and return air registers. This reduces air flow through the system which shortens equipment service life as well as increasing operating costs.
2. Check all power fuses or circuit breakers to be sure that they are the correct rating.
3. Periodic cleaning of the outdoor coil to permit full and unrestricted airflow circulation is essential.

## PRESSURE SERVICE PORTS

High and low pressure service ports are installed on all units so that the system operating pressures can be observed. Pressure tables can be found in Table 9 in this manual covering all models on cooling cycle. It is imperative to match the correct pressure table to the unit by model number.

## REFRIGERANT CHARGE

The correct system R-22 charge is shown on the unit rating plate. Optimum unit performance will occur with a refrigerant charge resulting in a suction line temperature (6" from compressor) as shown in Table 8.

TABLE 8

Model	Rated Airflow	95 Degree F OD Temperature	82 Degree F OD Temperature
P1124A2	800	56 - 58	63 - 65
P1130A2	1150	56 - 58	63 - 65
P1136A2	1275	57 - 59	58 - 60

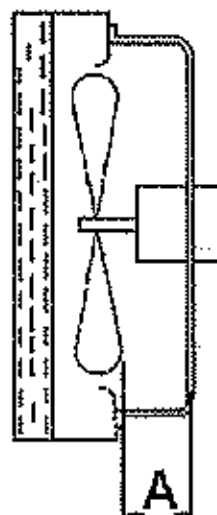
The above suction line temperatures are based upon 80°F dry bulb/67°F wet bulb (50% RH) temperature and rated airflow across the evaporator during cooling cycle.

## FAN BLADE SETTINGS

Shown in Figure 9 are the correct fan blade setting dimensions for proper air delivery across the outdoor coil.

Any service work requiring removal or adjustment in the fan and/or motor area will require that the dimensions below be checked and blade adjusted in or out on the motor shaft accordingly.

FIGURE 9  
FAN BLADE SETTING DIMENSIONS



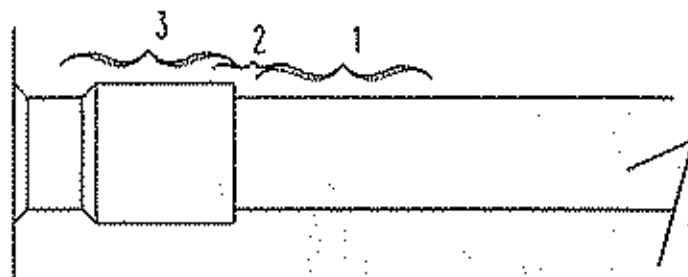
Model	Dimension A
P1124A2	1.00"
P1130A2	.75"
P1136A2	1.00"

## SUCTION AND DISCHARGE TUBE BRAZING

Compliant Scroll compressors have copper plated steel suction and discharge tubes. These tubes are far more rugged and less prone to leaks than copper tubes used on other compressors. Due to different thermal properties of steel and copper, brazing procedures may have to be changed from those commonly used.

- To disconnect: heat joint Areas 2 and 3 slowly and uniformly until braze material softens and the tube can be pulled out of suction fitting. (See Figure 10.)
- To connect:
  - Recommended brazing materials: silfos with minimum 5% silver or silver braze material with flux.
  - Reinsert tube into fitting.
  - Heat tube uniformly in Area 1 moving slowly to Area 2. When joint reaches brazing temperature, apply brazing material. (See Figure 10.)
  - Heat joint uniformly around the circumference to flow braze material completely around the joint.
  - Slowly move torch into Area 3 to draw braze material into joint. (See Figure 10.)
  - Do not overheat joint.

**FIGURE 10  
BRAZING DIAGRAM**



MIS-1179

**TABLE 9  
PRESSURE TABLE**

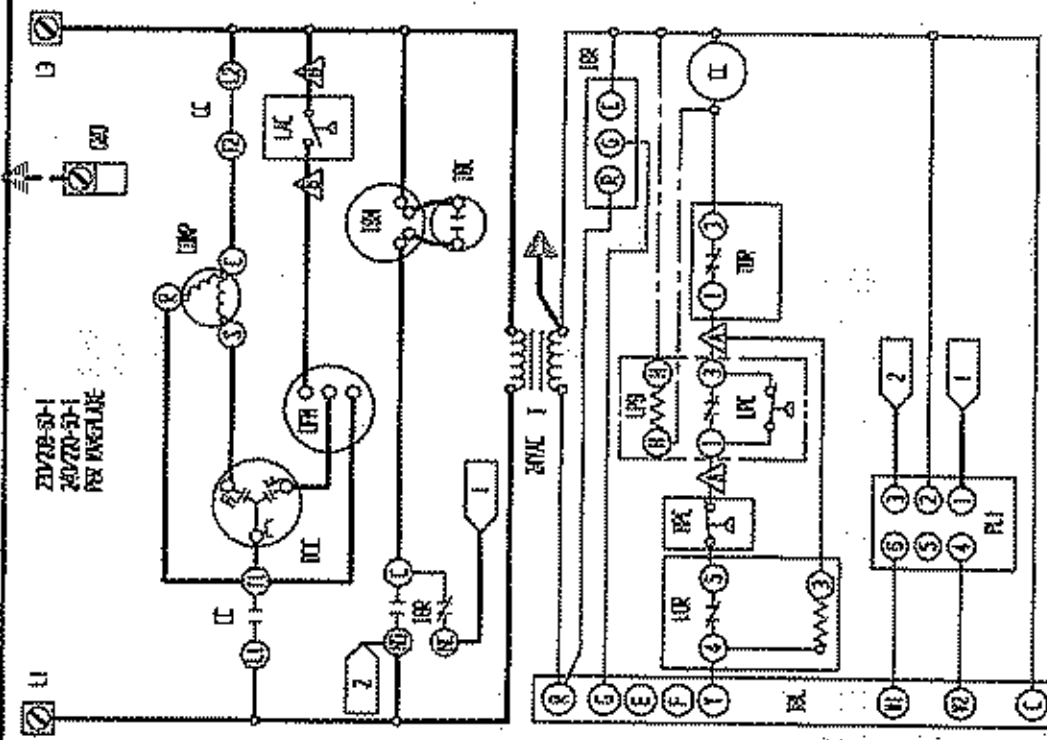
**COOLING**

Air Temperature Entering Outdoor Coil Degrees F

Model	Return Air Temperature	Pressure	75	80	85	90	95	100	105	110	115
P1124A2	75 deg. DB 62 deg. WB	Low Side	70	74	77	79	80	82	83	84	85
		High Side	219	220	224	234	248	258	276	293	316
	80 deg. DB 67 deg. WB	Low Side	75	79	82	84	86	88	89	90	91
		High Side	224	225	230	240	254	265	283	300	324
	85 deg. DB 72 deg. WB	Low Side	81	85	88	90	92	95	96	97	98
		High Side	232	233	238	248	263	274	293	311	335
P1130A2	75 deg. DB 62 deg. WB	Low Side	73	75	76	77	79	80	81	82	83
		High Side	200	219	234	254	271	288	307	327	342
	80 deg. DB 67 deg. WB	Low Side	75	80	81	82	84	85	86	87	88
		High Side	205	225	240	260	278	295	315	335	351
	85 deg. DB 72 deg. WB	Low Side	84	86	87	88	90	91	92	94	95
		High Side	212	233	248	269	287	306	326	347	363
P1136A2	75 deg. DB 62 deg. WB	Low Side	67	71	73	75	77	78	79	80	81
		High Side	195	215	229	249	263	282	302	317	336
	80 deg. DB 67 deg. WB	Low Side	72	76	78	80	82	84	85	86	87
		High Side	200	220	235	255	270	290	310	325	345
	85 deg. DB 72 deg. WB	Low Side	77	82	84	86	88	90	91	92	94
		High Side	207	228	243	264	279	300	321	336	357







240/240-50-1  
240/240-50-1  
PER WAGNER

U1

U2

U3

U4

U5

U6

U7

U8

U9

U10

U11

U12

U13

U14

U15

U16

U17

U18

U19

U20

U21

U22

U23

U24

U25

U26

U27

U28

U29

U30

U31

U32

U33

U34

U35

U36

U37

U38

U39

U40

U41

U42

U43

U44

U45

U46

U47

U48

U49

U50

U51

U52

U53

U54

U55

U56

U57

U58

U59

U60

U61

U62

U63

U64

U65

U66

U67

U68

U69

U70

U71

U72

U73

U74

U75

U76

U77

U78

U79

U80

U81

U82

U83

U84

U85

U86

U87

U88

U89

U90

U91

U92

U93

U94

U95

U96

U97

U98

U99

U100

U101

U102

U103

U104

U105

U106

U107

U108

U109

U110

U111

U112

U113

U114

U115

U116

U117

U118

U119

U120

U121

U122

U123

U124

U125

U126

U127

U128

U129

U130

U131

U132

U133

U134

U135

U136

U137

U138

U139

U140

U141

U142

U143

U144

U145

U146

U147

U148

U149

U150

U151

U152

U153

U154

U155

U156

U157

U158

U159

U160

U161

U162

U163

U164

U165

U166

U167

U168

U169

U170

U171

U172

U173

U174

U175

U176

U177

U178

U179

U180

U181

U182

U183

U184

U185

U186

U187

U188

U189

U190

U191

U192

U193

U194

U195

U196

U197

U198

U199

U200

U201

U202

U203

U204

U205

U206

U207

U208

U209

U210

U211

U212

U213

U214

U215

U216

U217

U218

U219

U220

U221

U222

U223

U224

U225

U226

U227

U228

U229

U230

U231

U232

U233

U234

U235

U236

U237

U238

U239

U240

U241

U242

U243

U244

U245

U246

U247

U248

U249

U250

U251

U252

U253

U254

U255

U256

U257

U258

U259

U260



