INSTALLATION INSTRUCTIONS

SINGLE PACKAGE AIR CONDITIONERS

MODELS
P1142A3
P1148A1
P1060A1



Bard Manufacturing Company
Bryan, Ohio 43506

Since 1914 . . . Moving ahead, just as planned

Manual : 2100-324B
Supersedes: 2100-324A
File: Volume II Tab 10
Date: 04-01-02

Contents

Getting Other Informations and Publications 1

General Instructions

Important	4
Shipping Damage	4
General	4
Field-Installed Heater Packages (Optional)	4

Installation

Location	6
Typical Installations	6
Condensate Drain Trap	9
Air Filters	9
Wiring – Main Power	10
Wiring – 24V Low Voltage Control Circuit	10
Transformer Taps	10
Thermostats	10

Start Up and Operation

Three Phase Scroll Compressor Start Up Information	11
Sequence of Operation	11
Start Up Notes	11
High Pressure Switch and Lockout Relay	11

Service and Troubleshooting

Service Hints	12
Pressure Service Ports	12
Refrigerant Charge	12
Fan Blade Settings	12
Suction and Discharge Tube Brazing	12
Pressure Table	13

Figures

Figure 1 Prefabricated Rood Curb Specifications	5
Figure 2 Field Fabricated Curbing	5
Figure3 Elevated Mounting Platforms	7
Figure 4 Airflow and Service Access Clearances	7
Figure 5 Roof Top Application	8
Figure 6 Slab Mounting at Ground Level	8
Figure 7 Condensate Drain Trap	9
Figure 8 Low Voltage Wiring	10
Figure 9 Fan Blade Setting Dimensions	12
Figure 10 Brazing Diagram	13

Tables

Table 1 Electrical Data	2
Table 2 Optional Field Installed Heater Packages	2
Table 3 Optional Field Installed Heater Table	3
Table 4 Maximum ESP of Operation	4
Table 5 Rated CFM and Rated ESP	6
Table 5A ESP in Inches H ₂ O	6
Table 6 Air Filter Area and Size	9
Table 7 Thermostat Wire Size	10
Table 8 Wall Thermostat and Subbase Combinations	10
Table 9 Refrigerant Charge	12
Table10 Pressure Table	13

Getting Other Information and Publications

These publications can help you install the air conditioner or heat pump. You can usually find these at your local library or purchase them directly from the publisher. Be sure to consult current edition of each standard.

National Electrical Code ANSI/NFPA 70

Standard for the Installation ANSI/NFPA 90A
of Air Conditioning and
Ventilating Systems

Standard for Warm Air ANSI/NFPA 90B
Heating and Air
Conditioning Systems

Load Calculation for ACCA Manual J
Residential Winter and
Summer Air Conditioning

Duct Design for Residential ACCA Manual D
Winter and Summer Air Conditioning
and Equipment Selection

For more information, contact these publishers:

ACCA **Air Conditioning Contractors of America**
1712 New Hampshire Ave. N.W.
Washington, DC 20009
Telephone: (202) 483-9370
Fax: (202) 234-4721

ANSI **American National Standards Institute**
11 West Street, 13th Floor
New York, NY 10036
Telephone: (212) 642-4900
Fax: (212) 302-1286

ASHRAE **American Society of Heating, Refrigerating,
and Air Conditioning Engineers, Inc.**
1791 Tullie Circle, N.E.
Atlanta, GA 30329-2305
Telephone: (404) 636-8400
Fax: (404) 321-5478

NFPA **National Fire Protection Association**
Batterymarch Park
P.O. Box 9101
Quincy, MA 02269-9901
Telephone: (800) 344-3555
Fax: (617) 984-7057

**TABLE 1
ELECTRICAL DATA**

Model	Rated Volts & Phases	Operating Voltage Range	Maximum Unit Amps	① Maximum External Fuses or Ckt. Brk.	Minimum Circuit Ampacity	② Field Power Wiring	② Ground Wire Size
				Ckt. A		Ckt. A	Ckt. A
P1142A3	230/208-1	197 - 253	24.2	45	29	8	10
P1148A1	240/208-1	197 - 253	26.1	50	36	8	10
P1148A1-B	230/208-3	187-253	18.8	35	23	8	10
P1148A1-C	460-3	414-506	8.5	20	13	12	12
P1060A1	230/208-1	197 - 253	33.9	60	42	8	10
P1060A1-B	230/208-3	187 - 253	23.7	45	28	8	10
P1060A1-C	460-3	414 - 506	11.2	20	14	12	12

① Maximum time delay fuse or HACR type circuit breaker.

② 75 degree C cooper wire size, basic unit only.

**TABLE 2
OPTIONAL FIELD INSTALLED HEATER PACKAGES
ONLY TO BE USED WITH THE AIR CONDITIONING MODELS INDICATED**

Heater Package Model No.	Volts and Phase	P1142A3	P1148A1	P1148A1-B	P1148A1-C	P1160A1	P1160A1-B	P1160A1-C
EH5PB-A05	240/1	S	S	A	A	S	A	A
EH5PB-A10		S	S	A	A	S	A	A
EH5PB-A15		S	S	A	A	S	A	A
EH5PB-A20		S	S	A	A	S	A	A
EH5PB-B09	240/3		A	S	A	A	S	A
EH5PB-B15			A	S	A	A	S	A
EH5PB-B18			A	S	A	A	S	A
EH5PB-CO9	480/3		A	A	S	A	A	S
EH5PB-C15			A	A	S	A	A	S
EH5PB-B18			A	A	S	A	A	S

S – Standard application – Heater volts and phase same as basic unit

A – Alternate application – Heater volts and phase different from basic unit

**TABLE 3
OPTIONAL FIELD-INSTALLEDELECTRIC HEATER TABLE**

Heater Pkg. Model No.	Unit Volts Phase	Htr. KW & Capacity @ 240V (or 480V if applicable)		Htr. KW & Capacity @ 208 Volts		@ 240V or 480V as applicable Htr. Amps	Heater Internal Fuses	Circuit B				
		KW	BTUH	KW	BTUH			No. Field Ckts.	Minimum Circuit Ampacity	①	②	③
										Maximum Overcurrent Protection	Field Power Wiring	Ground Wire Size
EH5PB-A05	240/208-1	5	17,100	3.75	12,800	20.8		1	26	30	10	10
EH5PB-A10	240/208-1	10	34,100	7.50	26,000	41.7		1	53	60	6	10
EH5PB-A15	240/208-1	15	51,200	11.25	38,400	62.5	30/60	1	79	80	4	8
EH5PB-A20	240/208-1	20	68,200	15.00	51,200	83.2	60/60	1	104	110	2	6
EH5PB-B09	240/208-3	9	30,700	6.75	23,000	21.7		1	28	30	10	10
EH5PB-B15	240/208-3	15	51,200	11.25	38,400	36.2		1	46	50	8	10
EH5PB-B18	240/208-3	18	61,400	13.50	46,100	43.4		1	55	60	6	10
EH5PB-C09	460/3	9	30,700	6.75	23,000	10.8		1	15	15	14	14
EH5PB-C15	460/3	15	51,200	11.25	38,400	18.0		1	23	25	10	10
EH5PB-C18	460/3	18	61,400	13.50	46,100	21.7		1	28	30	10	10

- ① Time delay fuses or "HACR" type circuit breakers must be used for 60 and smaller sizes. Standard fuses or circuit breakers are suitable for sizes 70 and larger.
- ② Based on wire suitable for 75° C. Other wiring materials must be rated for marked "Minimum Circuit Ampacity" or greater.
- ③ Based upon Table 250-95 of N.E.C. 1993. See electrical data for basic heat pump for Circuit A wiring specification requirements.

***IMPORTANT:** While this electrical data is presented as a guide, it is important to electrically connect properly size fuses and conductor wires in accordance with the National Electrical Code and all existing local codes.*

GENERAL INSTRUCTIONS

IMPORTANT

The equipment covered in this manual is to be installed by trained, experienced service and installation technicians. All duct work, supply and return ducts, must be properly sized for the design air flow requirement of the equipment. ACCA is an excellent guide to proper sizing. All duct work or portions thereof not in the conditioned space should be properly insulated in order to both conserve energy and prevent condensation or moisture damage.

SHIPPING DAMAGE

Upon receipt of equipment, the carton should be checked for external signs of shipping damage. If damage is found, the receiving party must contact the last carrier immediately, preferably in writing, requesting inspection by the carrier's agent.

GENERAL

The refrigerant system is completely assembled and charged. All internal wiring is complete.

The unit is designed for use with or without duct work. Flanges are provided for attaching the supply and return ducts.

These instructions explain the recommended method to install the air cooled self-contained unit and the electrical wiring connections to the unit.

These instructions and any instructions packaged with any separate equipment required to make up the entire heat pump system should be carefully read before beginning the installation. Note particularly "Starting Procedure" and any tags and/or labels attached to the equipment.

While these instructions are intended as a general recommended guide, they do not supersede any national and/or local codes in any way. Authorities having jurisdiction should be consulted before the installation is made.

FIELD INSTALLED HEATER PACKAGES (OPTIONAL)

These packaged heat pumps are manufactured without supplementary electric heaters. Supplementary heaters EH5PB series (to fit P1142A3, P1148A1, and P1160A1) are available for simple, fast, field installation.

A separate field power circuit is required for the supplementary heaters.

IMPORTANT: Refer to Table 4 and 5 when designing duct work for maximum available static pressure with heater installed.

Refer to the electrical data shown on pages 2 and 3 for proper application information on all available heater combinations and what units they can be used with. It also shows the applicable circuit ampacities, fuse size, and wire size for each heater combination.

Refer to the installation instructions packed with the heater for details on how to insert it into the basic unit.

**TABLE 4
MAXIMUM ESP OF OPERATION**

	P1142A3	P1148A1	P1060A1
A00	.50	.50	.50
A05	.50	.50	.50
A10	.50	.50	.50
A15	.40	.50	.50
A20	.40	.50	.50
B00	---	.50	.50
B09	---	.50	.50
B15	---	.50	.50
B18	---	.50	.50
C00	---	.50	.50
C09	---	.50	.50
C15	---	.50	.50
C18	---	.50	.50

**FIGURE 1
 PREFABRICATED ROOF CURB SPECIFICATIONS
 HEAVY GAUGE GALVANIZED WITH WOOD NAILING STRIP, WELDED/LEAKPROOF
 ONE PIECE CONSTRUCTION – READY TO INSTALL**

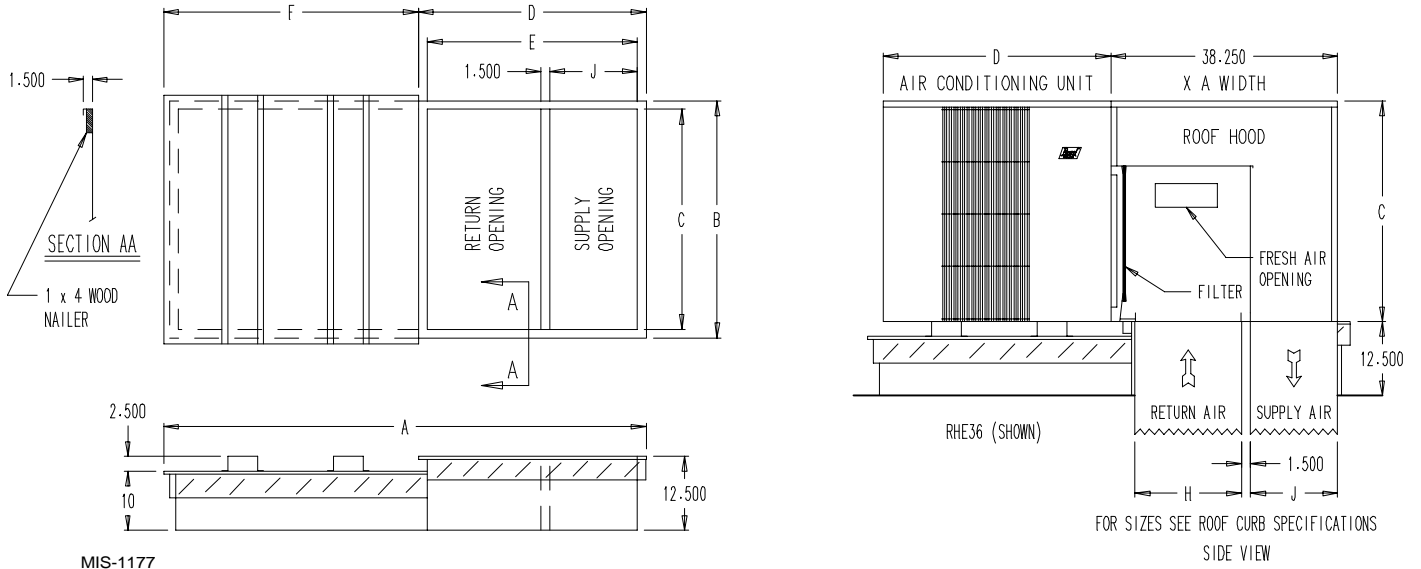

MIS-1177

CURB AND ROOF DETAILS

Roof Curb	A	B	C*	D	E	F	J*	H*	Roof Hood Model	Air Conditioning Units
9042-004	82-3/8	44-1/8	41-1/8	38-3/8	35-3/8	44	14-3/4	19-1/8	RHE60	P1142A3, P1148A1, P1060A1

*Duct Sizing Information

Return Air Dimension "C" is length
 Return Air Dimension "H" is width

Supply Air Dimension "C" is length
 Supply Air Dimension "J" is width

**FIGURE 2
 FIELD FABRICATED CURBING**

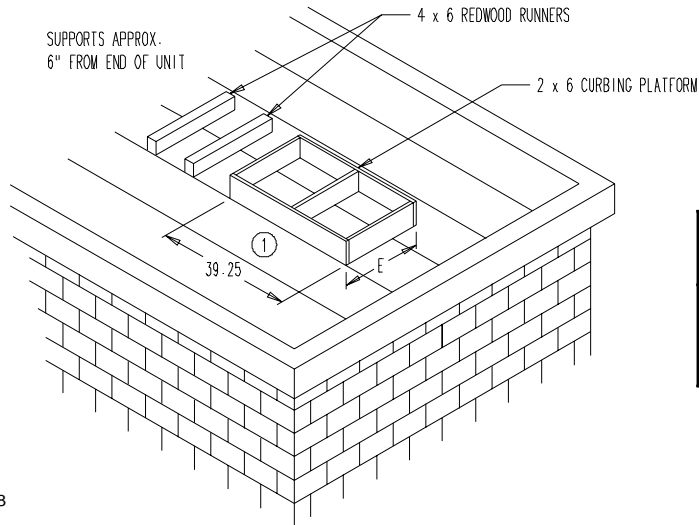

MIS-1178

Roof Hood Model	Unit Model	E
RHE60	P1142A3 P1148A1 P1060A1	44-7/8

① A SEPARATE METAL FLASHING SHOULD BE INSTALLED AROUND WOOD CURBING. CAULK & SEAL ALL JOINTS & WEATHERPROOF.

INSTALLATION

LOCATION

GENERAL

The unit must be located outside, or in a well ventilated area. It must not be in the space being heated or cooled. A sound absorbing material should be considered if the unit is to be installed in such a position or location that might cause transmission of sound or vibration to the living area or adjacent buildings.

SLAB MOUNTING

In areas where winter temperatures *DO NOT* go below 32° F for periods over twelve hours, the unit may be slab mounted at grade level. When installing unit at grade level, install on a concrete slab at least four inches above finished grade level. Slab should have a slope tolerance away from the building structure of at least 1/4 inch per foot, while being level from side to side. Place slab in a location where runoff water from higher ground will not collect around unit. See Figure 3.

A minimum of 18 inches should be provided between the coil inlet and any building surfaces. Provide at least four feet between coil outlet and any building wall, fences or other vertical structures. Provide a minimum of three feet clearance on the service access side of the unit. See Figure 4

ROOF MOUNTING

When a unit is installed in areas where low ambient temperatures or strong winter winds exist, it should be placed for prevailing winter winds are not in direct line with the outdoor coil. If this is not possible, a wind barrier should be constructed. Place barrier 24 inches from the coil inlet side of the unit and in the direction of prevailing winds. Size barrier at least the same height and width as the unit. This may be necessary on ground level installations, also. See Figure 5.

WINTER INSTALLATION BELOW 32°F

In areas where winter conditions go below 32°F for extended periods, the unit must be elevated above the mounting surface to prevent snowfall or ice accumulation from interfering with the operation of the unit. A minimum of twelve inch elevation is recommended, while greater elevation may be required for areas of high snow accumulation. Poured concrete, steel framework, brick, cement block, etc., can be utilized to construct a suitable raised mounting platform. See Figure 6.

DUCT WORK

Refer to Tables 4, 5 and 5A when designing duct work for maximum static pressure available with the specific model and heater package being installed.

**TABLE 5
RATED CFM AND
EXTERNAL STATIC PRESSURE (ESP)
WET COIL (COOLING)**

Model	Rated CFM	Rated ESP	Recommended Air Flow Range
P1142A3	1400	.20	1260 - 1540 CFM
P1148A1	1550	.40	1400 - 1700 CFM
P1060A1	1700	.20	1530 - 1870 CFM

TABLE 5A

ESP Inches H ₂ O	P1142A3 PH11421 Dry / Wet	P1148A1 PH1048 Dry / Wet	P1060A1 PH1060 Dry / Wet
0	1650 / 1625	1950 / 1920	1850 / 1850
.1	1550 / 1525	1860 / 1830	1800 / 1780
.2	1435 / 1400	1780 / 1750	1725 / 1700
.3	1340 / 1310	1680 / 1660	1660 / 1625
.4	1230 / 1210	1580 / 1550	1580 / 1540
.5	1120 / 1100	1500 / 1480	1500 / 1475

TYPICAL INSTALLATIONS

- ROOF MOUNTED** – The unit is mounted on a sturdy base on the roof of the building. Return air to the unit is brought through a single return grille (grilles with built-in filters are best since they enable easy access for filter changing). Return air ducts are attached to the lower section of the front panel. Supply air is brought from the unit to attic duct work or to a furred down hall. Supply air duct is attached to the top of the front panel.

CAUTION: All outdoor duct work must be thoroughly insulated and weatherproofed. All attic duct work must be thoroughly insulated. Two inch thick insulation with suitable vapor barrier is recommended for both outdoor and attic runs.

In roof top installation, as in all installations, the air conditioner must be level from side to side. However, the unit should have a pitch along the length to assure complete external drainage of precipitation and of defrost condensate.

- CRAWL SPACE** – Duct work installed in crawl space must be well insulated and provided with a vapor barrier. In addition, the crawl space must be thoroughly ventilated and provided with a good vapor barrier as a ground cover. It is most desirable to install the unit will be outdoors rather than inside the crawl space, so that it will be readily accessible for service.

**FIGURE 3
ELEVATED MOUNTING PLATFORMS**

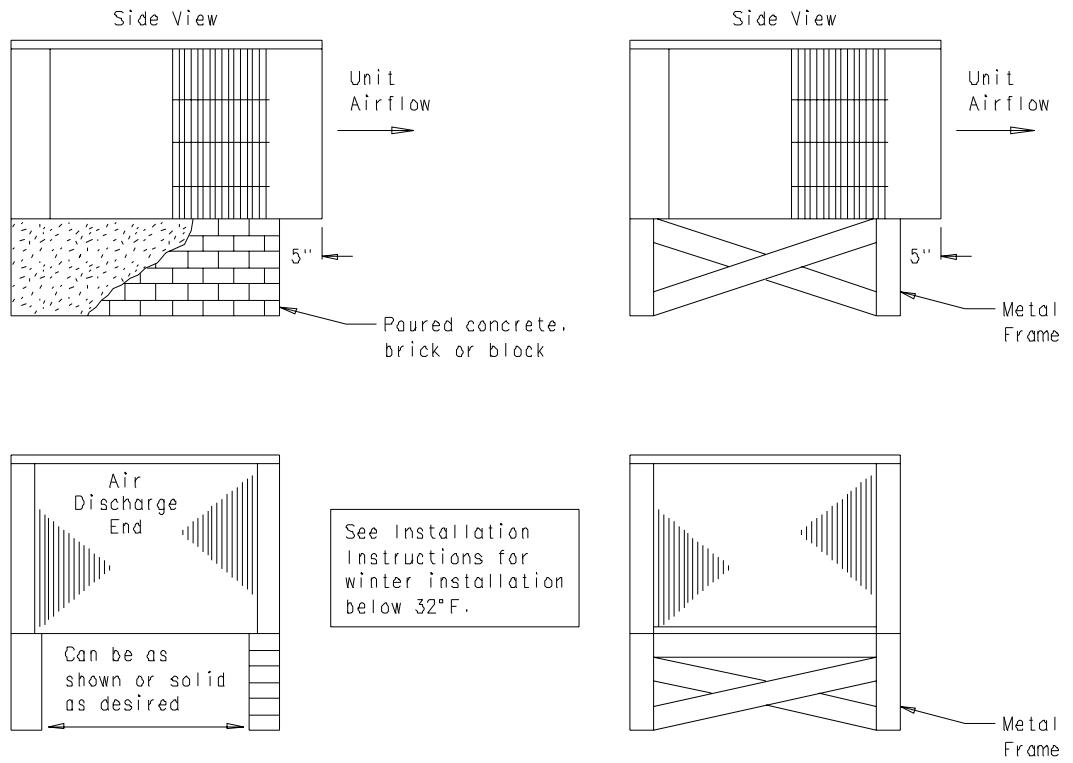

**FIGURE 4
AIRFLOW AND SERVICE ACCESS CLEARANCES**

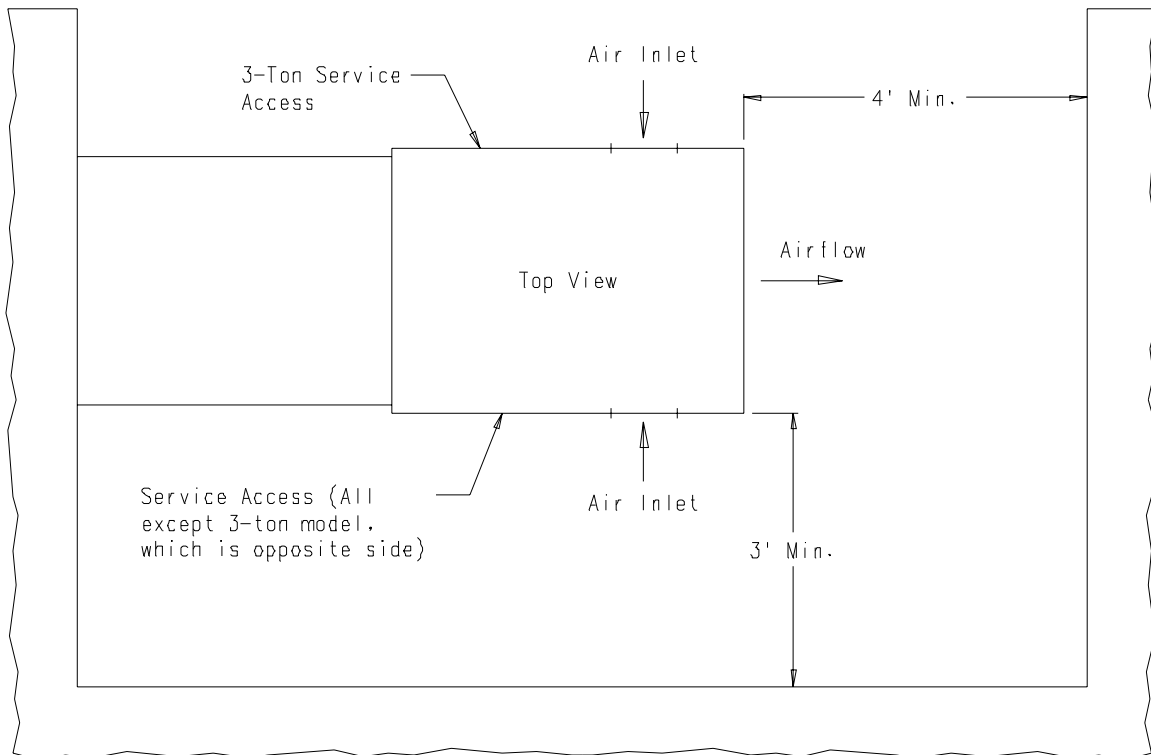
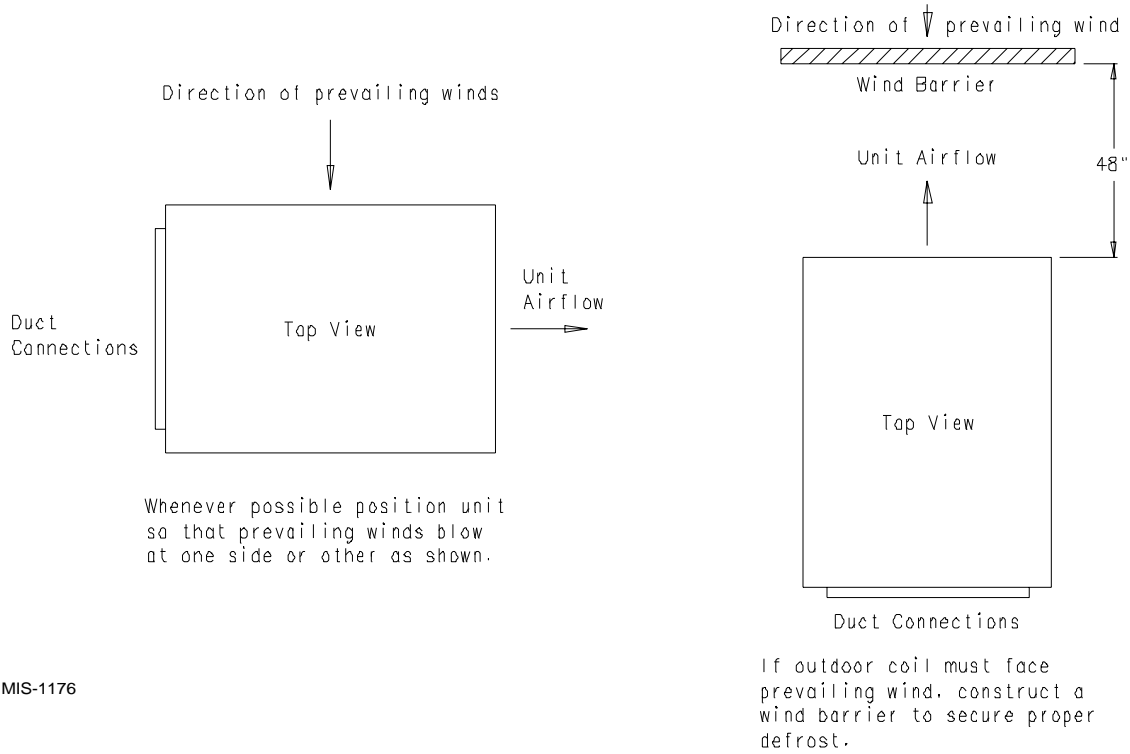
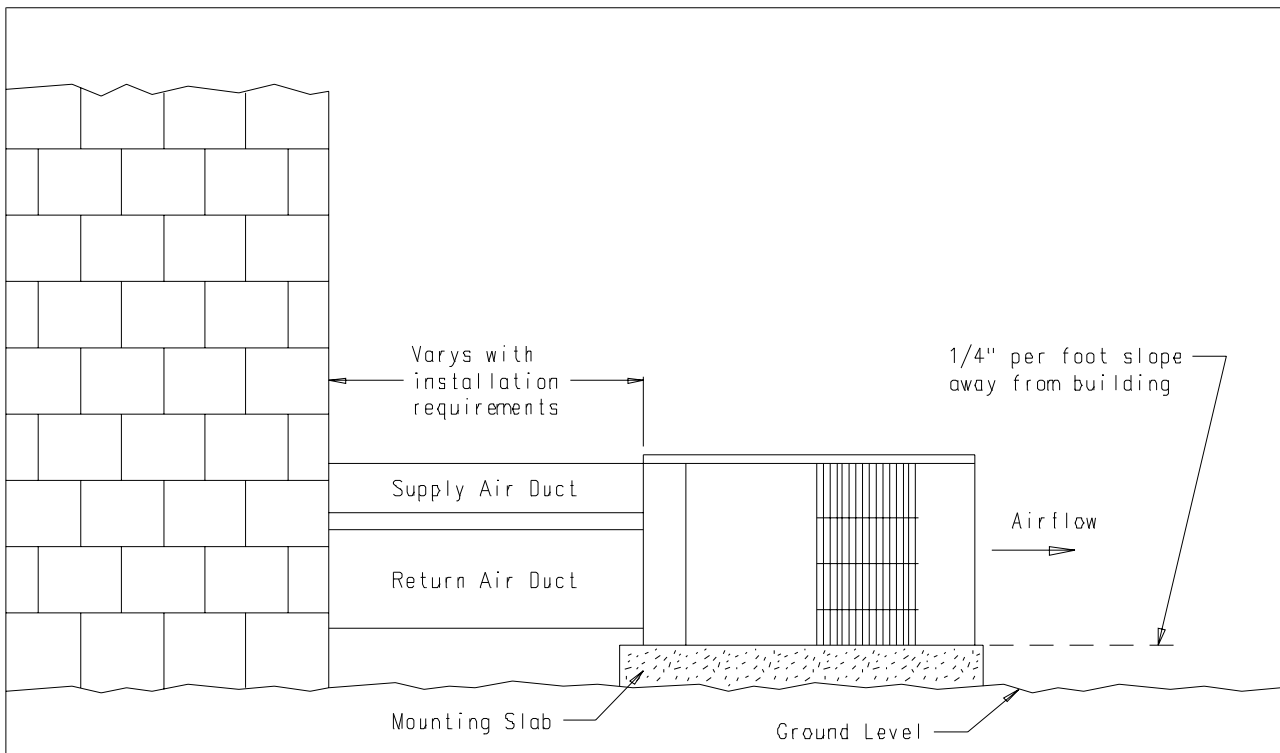

FIGURE 5
ROOFTOP APPLICATION
(MAY ALSO BE REQUIRED FOR GROUND LEVEL INSTALLATIONS.)



MIS-1176

FIGURE 6
SLAB MOUNTING AT GROUND LEVEL
(ABOVE 32° F OUTSIDE TEMPERATURE)



MIS-1184

WIRING – MAIN POWER

Refer to the unit rating plate for wire sizing information and maximum fuse size. Each outdoor unit is marked with a “Minimum Circuit Ampacity”. This means that the field wiring used must be sized to carry that amount of current. If field installed heaters are added to the basic unit, a second separate power supply circuit will be required. The heater rating plate located adjacent to the basic unit rating plate will show the appropriate circuit ampacity fuse size, etc. (Also see “Electrical Data” on pages 2 and 3.) *All models are suitable for connection with copper wire only.* These instructions **must** be adhered to. Refer to the National Electrical Code for complete current carrying capacity data on the various insulation grades of wiring material.

The electrical specifications on page 2 and 3 lists fuse and wire sizes (75°F copper) for all models including the most commonly used heater sizes.

The unit rating plate lists a “Maximum Time Delay Fuse” or “HACR” type circuit breaker that is to be used with the equipment. The correct size must be used for proper circuit protection and also to assure that there will be no nuisance tripping due to the momentary high starting current of the compressor.

WIRING – 24V LOW VOLTAGE CONTROL CIRCUIT

Five (5) wires should be run from thermostat subbase to the 24V terminal board in the unit. A five conductor, 18 gauge copper, color-coded thermostat cable is recommended. The connection points are shown in Figure 8.

**TABLE 7
THERMOSTAT WIRE SIZE**

Transformer VA	FLA	Wire Gauge	Maximum Distance In Feet
55	2.3	20	45
		18	60
		16	100
		14	160
		12	250

TRANSFORMER TAPS

230/208V, 1 phase and 3 phase equipment employ dual primary voltage transformers. All equipment leaves the factory wired on 240V tap. For 208V operation, reconnect from 240V to 208V tap. The acceptable operating voltage range for the 240 and 208V taps are:

TAP	RANGE
240	253 – 216
208	220 – 187

NOTE: The voltage should be measured at the field power connection point in the unit and while the unit is operating at full load (maximum amperage operating condition).

THERMOSTATS

See specific wiring information for the different models, heater KWs, and voltages on pages 14 through 17.

**TABLE 8
WALL THERMOSTAT AND SUBBASE COMBINATIONS**

Thermostat	Subbase	Predominate Features
8403-002 T87F3111	8404-003 Q539A1220	1 stage heat, 1 stage cool, Mercury System: Heat-off-cool Fan: on-auto
8403-041 T8034C1499	—	1 stage heat, 1 stage cool, Mercury System: Heat-off-cool Fan: on-auto
8403-049 1F93-380	—	2 stage heat, 2 stage cool Electronic Programmable
8403-043 CM200	—	1 stage heat, 1 stage cool, Mercury System: Heat-off-cool Fan: on-auto Snap Action
8403-048 T8400C1313	—	1 stage heat, 1 stage cool, Mercury System: Heat-off-cool Fan: on-auto Electronic Non-Programmable
8403-019 T874C1760	8404-012 Q674A1001	2 stage heat, 1 stage cool, Mercury System: heat-auto-cool Fan: on-auto

IMPORTANT NOTE: *Only the thermostat and subbase combinations as shown above will work with this equipment. The thermostat and subbase MUST be matched, and correct operation can be assured only by proper selection and application of these parts.*

**FIGURE 8
LOW VOLTAGE WIRING**

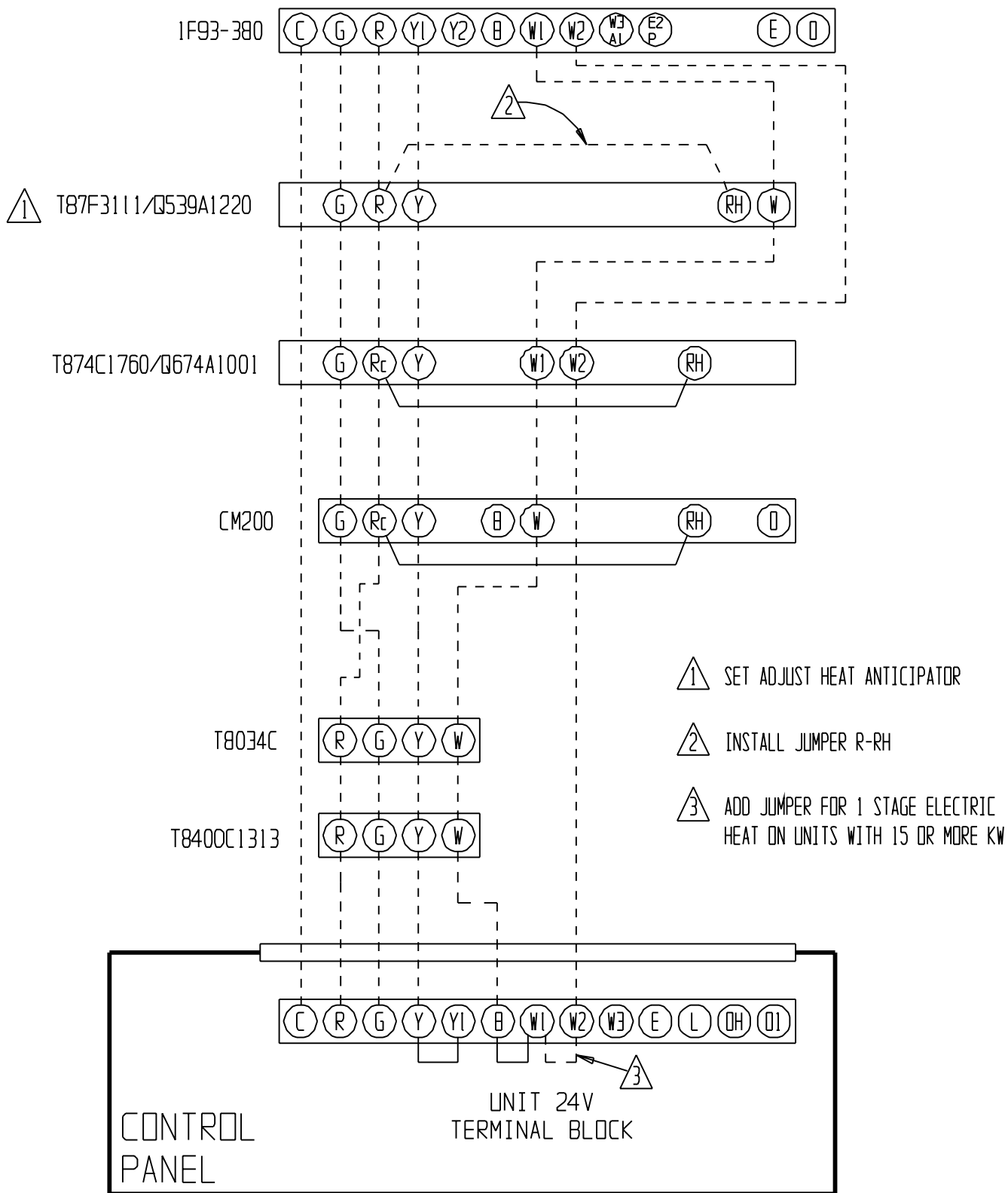

MIS-1180

START UP AND OPERATION

THREE PHASE SCROLL COMPRESSOR START UP INFORMATION

Scroll compressors, like several other types of compressors, will only compress in one rotational direction. Direction of rotation is not an issue with single phase compressors since they will always start and run in the proper direction.

However, three phase compressors will rotate in either direction depending upon phasing of the power. Since there is a 50-50 chance of connecting power in such a way as to cause rotation in the reverse direction, verification of proper rotation must be made. Verification of proper rotation direction is made by observing that suction pressure drops and discharge pressure rises when the compressor is energized. Reverse rotation also results in an elevated sound level over that with correct rotation, as well as, substantially reduced current draw compared to tabulated values.

Verification of proper rotation must be made at the time the equipment is put into service. If improper rotation is corrected at this time there will be no negative impact on the durability of the compressor. However, reverse operation for over one hour may have a negative impact on the bearing due to oil pump out.

NOTE: *If compressor is allowed to run in reverse rotation for several minutes the compressor's internal protector will trip.*

All three phase ZR*3 compressors are wired identically internally. As a result, once the correct phasing is determined for a specific system or installation, connecting properly phased power leads to the same Fusite terminals should maintain proper rotation direction.

The direction of rotation of the motor may be changed by reversing any two line connections to the unit.

SEQUENCE OF OPERATION

COOLING – Circuit R-Y makes at thermostat pulling in compressor contactor starting the compressor and outdoor motor. The G (indoor motor) circuit is automatically completed on any call for cooling operation, or can be energized by manual fan switch on subbase for constant air circulation.

HEATING – A circuit R-W1 is completed on each heating cycle energizing electric heat if so equipped.

START UP NOTES

For improved start up performance, wash the indoor coil with dishwasher detergent

COMPRESSOR CONTROL MODULE

The compressor control is an anti-short cycle/lockout timer with high and low pressure switch monitoring and alarm output.

ADJUSTABLE DELAY-ON-MAKE AND BREAK TIMER

On a call for compressor operation the *delay-on-make* period begins which will be 10% of the *delay-on-break* setting. When the delay-on-make is complete and the high pressure switch (and low pressure switch if employed) is closed, the compressor contactor is energized. Upon shutdown the delay-on-break timer starts and prevents restart until the delay-on-break and delay-on-make periods have expired.

HIGH PRESSURE SWITCH AND LOCKOUT SEQUENCE (Standard Feature)

If the high pressure switch opens, the compressor contactor will de-energize immediately. The lockout timer will go into a *soft lockout* and stay in soft lockout until the high pressure switch closes **and** the delay-on-make time has expired. If the high pressure switch opens again in this same operating cycle the unit will go into *manual lockout* condition and the alarm circuit will energize. Recycling the wall thermostat resets the manual lockout.

LOW PRESSURE SWITCH, BYPASS, AND LOCKOUT SEQUENCE

NOTE: *The low pressure switch is an optional control and the bypass and lockout sequence are part of the standard compressor control module.*

If the low pressure switch opens for more than 120 seconds, the compressor contactor will de-energize and go into a soft lockout. Regardless the state of the low pressure switch, the contactor will reenergize after the delay-on-make time delay has expired. If the low pressure switch remains open or opens again for longer than 120 seconds the unit will go into manual lockout condition and the alarm circuit will energize. Recycling the wall thermostat resets the manual lockout.

ALARM OUTPUT

Alarm terminal is output connection for applications where alarm signal is desired. This terminal is powered whenever compressor is locked out due to HPC or LPC sequences as described.

NOTE: Both high and low pressure switch controls are inherently automatic reset devices. The high pressure switch and low pressure switch cut out and cut in settings are fixed by specific air conditioner or heat pump unit model. The lockout features, both soft and manual, are a function of the Compressor Control Module.

ADJUSTMENTS

ADJUSTABLE DELAY-ON-MAKE AND DELAY-ON-BREAK TIMER

The potentiometer is used to select Delay-on-Break time from 30 seconds to 5 minutes. Delay-on-Make (DOM) timing on power-up and after power interruptions is equal to 2 minutes plus 10% of Delay-on-Break (DOB) setting:

0.5 minute	(30 seconds)	DOB =	123 second	DOM
1.0 minute	(60 seconds)	DOB =	126 second	DOM
2.0 minute	(120 seconds)	DOB =	132 second	DOM
3.0 minute	(160 seconds)	DOB =	138 second	DOM
4.0 minute	(240 seconds)	DOB =	144 second	DOM
5.0 minute	(300 seconds)	DOB =	150 second	DOM

SERVICE AND TROUBLESHOOTING

SERVICE HINTS

1. Caution homeowner to maintain clean air filters at all times. Also, not to needlessly close off supply and return air registers. This reduces air flow through the system which shortens equipment service life as well as increasing operating costs.
2. Check all power fuses or circuit breakers to be sure that they are the correct rating.
3. Periodic cleaning of the outdoor coil to permit full and unrestricted airflow circulation is essential.

PRESSURE SERVICE PORTS

High and low pressure service ports are installed on all units so that the system operating pressures can be observed. Pressure tables can be found in Table 10 in this manual covering all models on cooling cycle. It is imperative to match the correct pressure table to the unit by model number.

REFRIGERANT CHARGE

The correct system R-22 charge is shown on the unit rating plate. Optimum unit performance will occur with a refrigerant charge resulting in a suction line temperature (6" from compressor) as shown in Table 9.

TABLE 9

Model	Rated Airflow	95 Degree F OD Temperature	82 Degree F OD Temperature
P1142A3	1400	57 - 59	58 - 60
P1148A1	1550	55 - 57	59 - 61
P0160A1	1700	47 - 49	54 - 56

The above suction line temperatures are based upon 80°F dry bulb/67°F wet bulb (50% RH) temperature and rated airflow across the evaporator during cooling cycle.

FAN BLADE SETTINGS

Shown in Figure 9 are the correct fan blade setting dimensions for proper air delivery across the outdoor coil.

Any service work requiring removal or adjustment in the fan and/or motor area will require that the dimensions below be checked and blade adjusted in or out on the motor shaft accordingly.

FIGURE 9
FAN BLADE SETTING DIMENSIONS

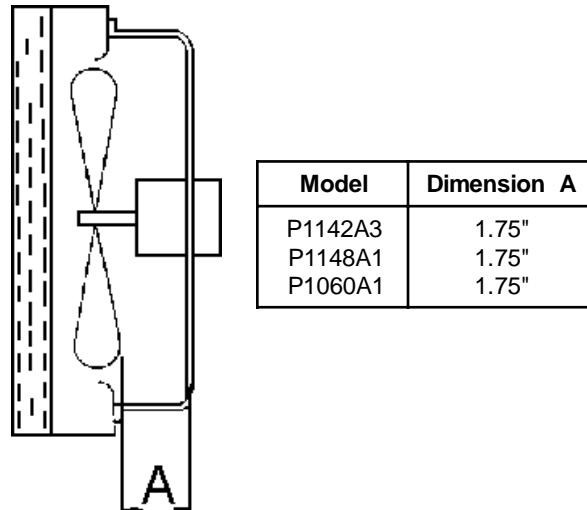

SUCTION AND DISCHARGE TUBE BRAZING

Compliant Scroll compressors have copper plated steel suction and discharge tubes. These tubes are far more rugged and less prone to leaks than copper tubes used on other compressors. Due to different thermal properties of steel and copper, brazing procedures may have to be changed from those commonly used.

- To disconnect: heat joint Areas 2 and 3 slowly and uniformly until braze material softens and the tube can be pulled out of suction fitting. (See Figure 10.)
- To connect:
 - Recommended brazing materials: silfos with minimum 5% silver or silver braze material with flux.
 - Reinsert tube into fitting.
 - Heat tube uniformly in Area 1 moving slowly to Area 2. When joint reaches brazing temperature, apply brazing material. (See Figure 10.)
 - Heat joint uniformly around the circumference to flow braze material completely around the joint.
 - Slowly move torch into Area 3 to draw braze material into joint. (See Figure 10.)
 - **Do not** overheat joint.

**FIGURE 10
BRAZING DIAGRAM**

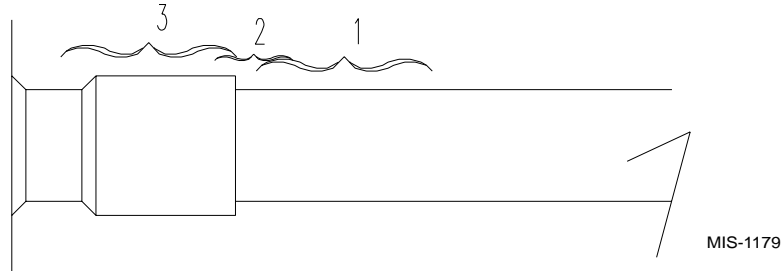
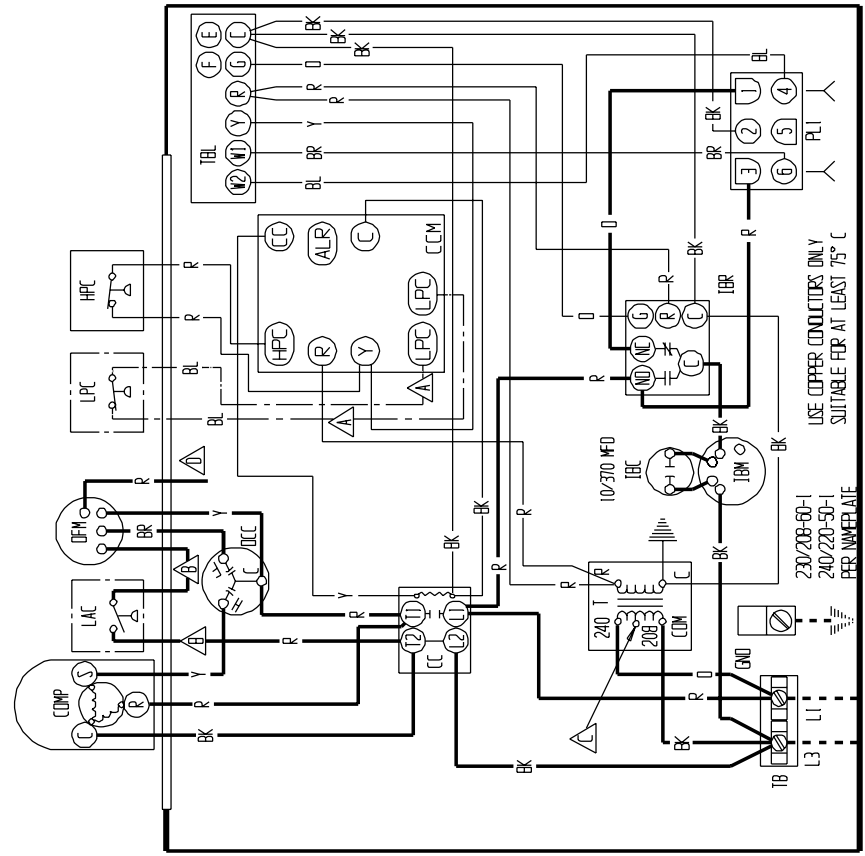
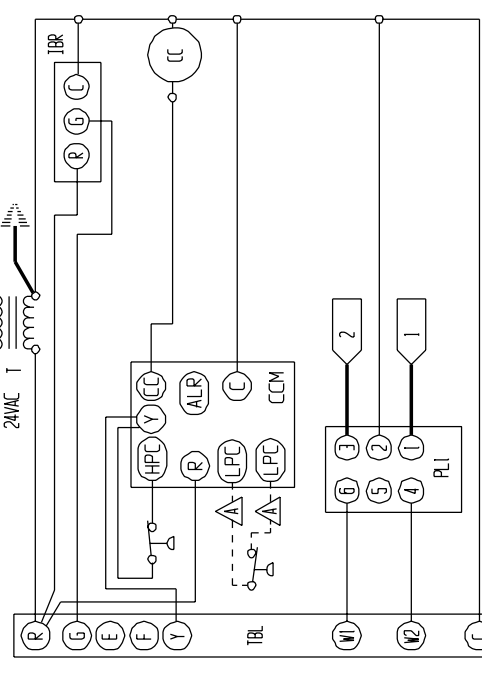
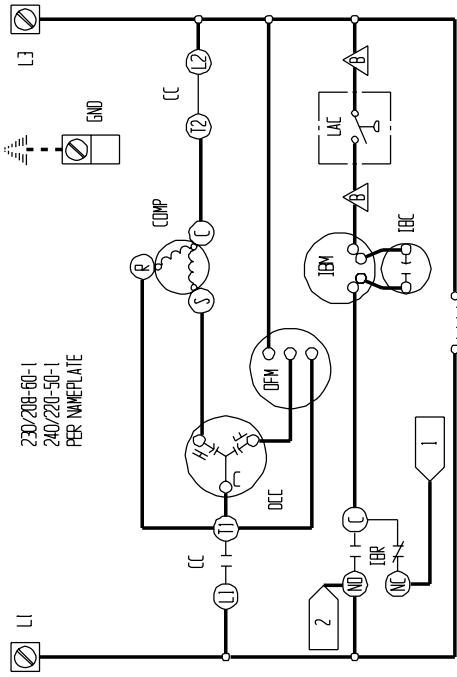

**TABLE 10
PRESSURE TABLE**

COOLING

Air Temperature Entering Outdoor Coil Degrees F

Model	Return Air Temperature	Pressure	75	80	85	90	95	100	105	110	115
P1142A3	75 deg. DB 62 deg. WB	Low Side High Side	70 208	72 223	75 239	77 254	78 271	79 288	80 305	81 324	82 342
	80 deg. DB 67 deg. WB	Low Side High Side	75 213	77 229	80 245	82 261	84 278	85 295	96 313	87 332	88 351
	85 deg. DB 72 deg. WB	Low Side High Side	81 220	83 237	86 254	88 270	90 288	91 305	92 324	94 344	95 363
P1148A1	75 deg. DB 62 deg. WB	Low Side High Side	73 203	74 217	75 231	76 246	78 264	79 278	80 294	81 312	82 330
	80 deg. DB 67 deg. WB	Low Side High Side	78 208	79 222	81 237	82 252	83 268	84 285	86 302	87 320	88 338
	85 deg. DB 72 deg. WB	Low Side High Side	83 215	85 230	87 245	88 261	87 273	91 295	92 313	93 331	94 350
P1060A1	75 deg. DB 62 deg. WB	Low Side High Side	65 214	66 230	68 247	69 264	70 284	72 299	74 318	75 336	76 355
	80 deg. DB 67 deg. WB	Low Side High Side	69 219	71 236	72 253	74 271	76 289	77 307	79 326	80 345	82 364
	85 deg. DB 72 deg. WB	Low Side High Side	74 227	76 244	78 262	79 280	81 296	83 318	85 337	86 357	88 377



MODEL	CAPACITOR	PART NO.
P100BA1	60/10 370	8552-059
P100BA1	80/10 370	8552-058

COMPONENT CODE	DESCRIPTION
CC	COMPRESSOR CAPACITOR
COM	COMPRESSOR CONTROL MODULE
COMP	COMPRESSOR
DCC	DUAL CAN CAPACITOR
GND	EQUIPMENT GROUND
HPC	HIGH PRESSURE CONTROL
IBC	INDOOR BLOWER CAPACITOR
IBR	INDOOR BLOWER MOTOR
IBL	INDOOR BLOWER RELAY
LAC	LOW AMBIENT CONTROL
LPB	LOW PRESSURE BYPASS RELAY
LPC	LOW PRESSURE CONTROL
DFC	OUTDOOR FAN CAPACITOR
DFM	OUTDOOR FAN MOTOR
PL1	PLUG #1
T	TRANSFORMER
TB	TERMINAL BLOCK
TBL	LOW VOLTAGE TERMINAL BLOCK

▲ Labeled Wires to 208V Tap for 208V Operation
 ▲ Red Wire for 50 Hz Operation Only
 ▲ High Voltage
 --- Low Voltage
 --- Accessory

BLACK	BROWN	RED	ORANGE	YELLOW	GREEN	BLUE	WHITE	VIOLET	PURPLE	PINK	TAN
BK	BR	R	O	Y	G	BL	W	V	PP	PK	TAN
OPTIONAL	---	---	---	---	---	---	---	---	---	---	---

COLOR CODE
 BARD MFG. CO.
 4064-116 C

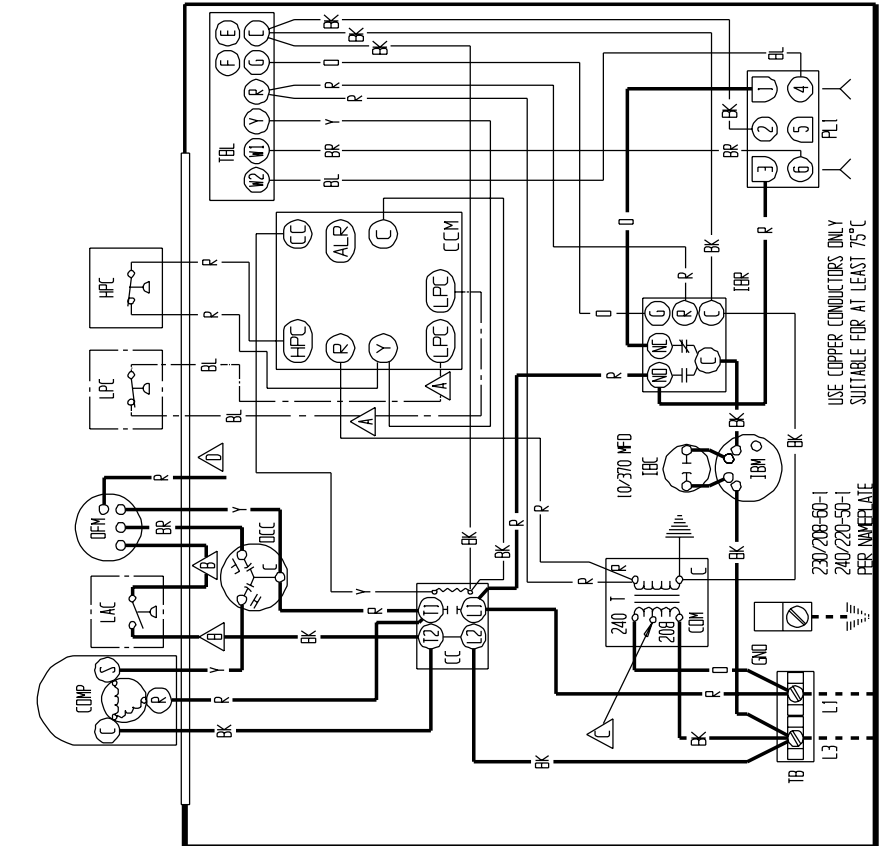
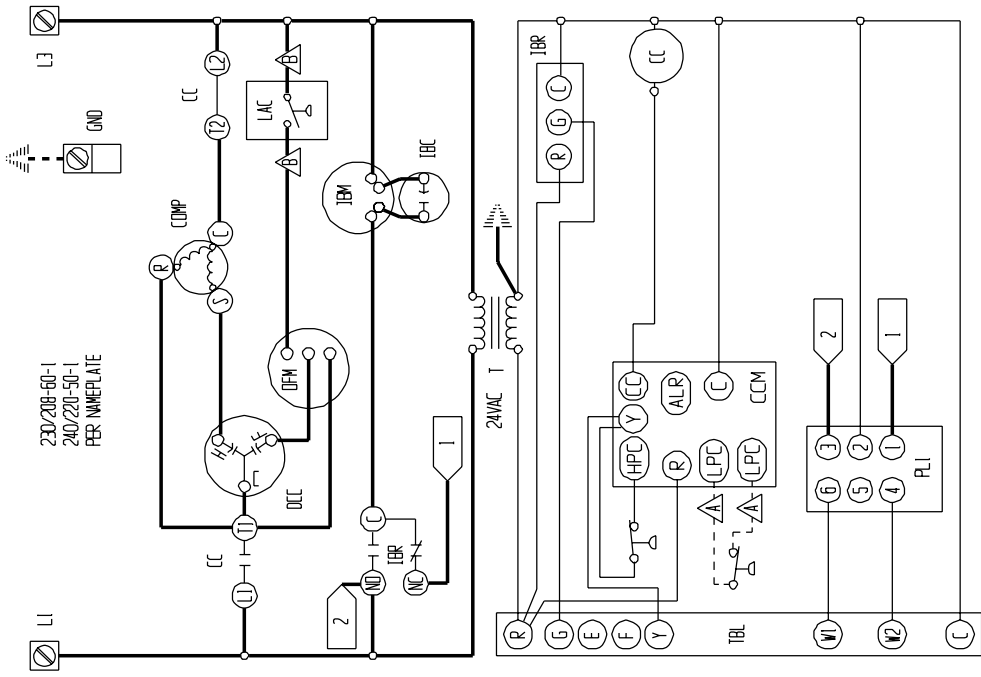

COMPONENT CODE	COMPONENT DESCRIPTION	PART NO.
CC	COMPRESSOR CONTACTOR	
CCM	COMPRESSOR CONTROL MODULE	
COMP	COMPRESSOR	55/70 440
DCC	DUAL CAN CAPACITOR	8552-056
FPM	EQUIPMENT GROUND	
HPC	HIGH PRESSURE CONTROL	
IBC	INDOOR BLOWER CAPACITOR	
IBM	INDOOR BLOWER MOTOR	
IBR	INDOOR BLOWER RELAY	
LAC	LOW AMBIENT CONTROL	

FACTORY STD.	FIELD	OPTIONAL
---	---	---
---	---	---
---	---	---

COLOR CODE	INDICATED COLOR
BK	BLACK
BR	BROWN
R	RED
O	ORANGE
Y	YELLOW
G	GREEN
BL	BLUE
W	WHITE
CS	GRAY
S	SLATE
V	VIOLET
P	PURPLE
PK	PINK
L	LAVENDER
T	TAN

<p>▲ Labeled wires connect if no options used.</p> <p>▲ Move red wire to 208V tap for 288V operation.</p> <p>▲ Red wire per 50 Hz. operation only.</p>	<p>BARD MFG. CO.</p> <p>4064-118 B</p>
--	---

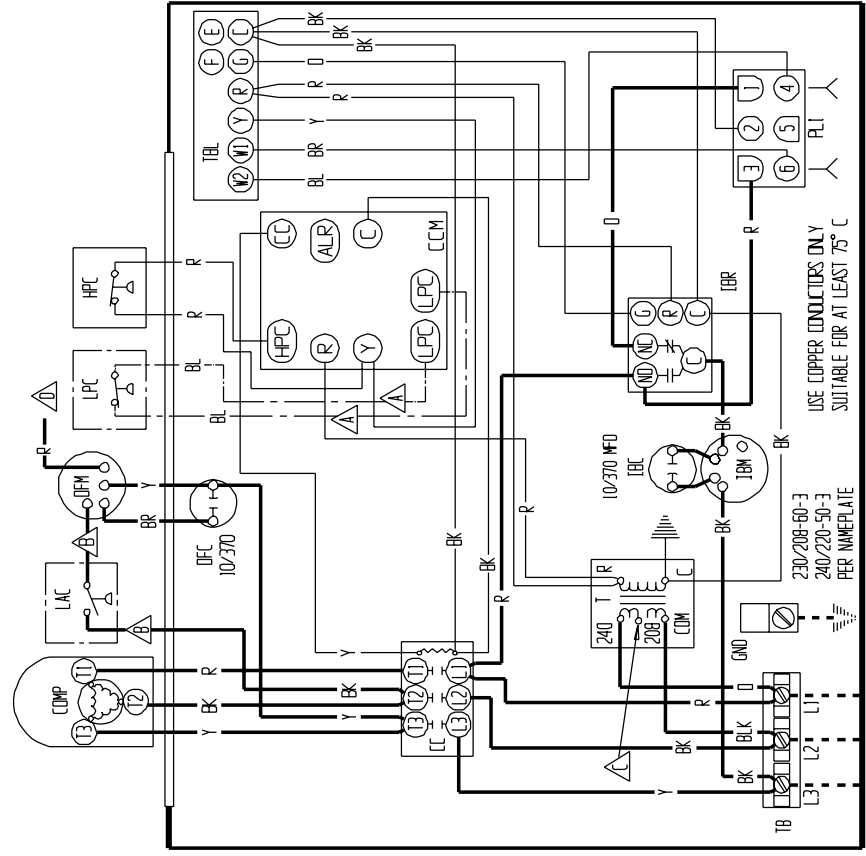
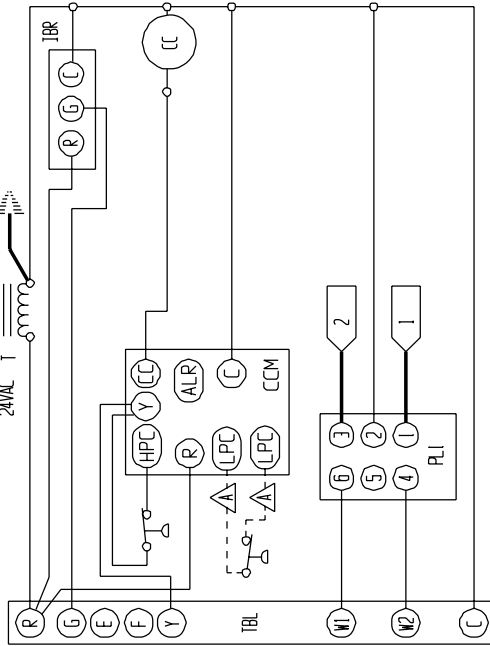
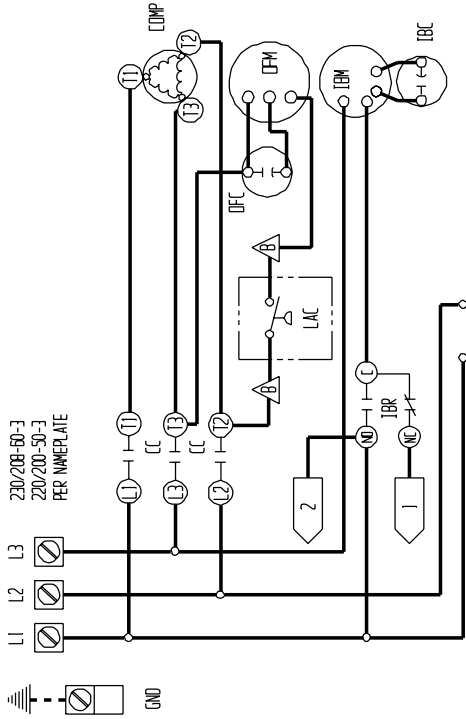

USE COPPER CONDUCTORS ONLY
SUITABLE FOR AT LEAST 75 °C

COMPONENT CODE	DESCRIPTION
CC	COMPRESSOR CONTACTOR
COM	COMPRESSOR CONTROL MODULE
COMP	COMPRESSOR
DCC	DUAL CAN CAPACITOR
EQ	EQUIPMENT GROUND
HPC	HIGH PRESSURE CONTROL
IBC	INDOOR BLOWER MOTOR
IBM	INDOOR BLOWER RELAY
IBR	INDOOR AMBIENT CONTROL
LAC	LOW PRESSURE BYPASS
LPB	LOW PRESSURE CONTROL
LPC	LOW PRESSURE CAPACITOR
DFC	OUTDOOR FAN CAPACITOR
DFM	OUTDOOR FAN MOTOR
PLI	PLUG #1
T	TRANSFORMER
TB	TERMINAL BLOCK
TBL	LOW VOLTAGE TERMINAL BLOCK

▲ Labeled wires connect if no options used. ▲ More red wire to 208V tap for 208V operation. ▲ Red wire for 50 Hz. Operation only.

Factory Std.	Field	Optional
High Voltage	---	---
Low Voltage	---	---
Accessory	---	---

Color Code	Y	G	BL	W	V	PK	T
BK	Black	Brown	Red	Orange	Yellow	Green	Tan
BR	Brown	Red	Orange	Yellow	Green	Pink	PK
R	Red	Orange	White	Blue	Purple	Gray	L
D	Orange	White	Blue	White	Gray	Slate	L

BARB MFG. CO.
4064-213 C

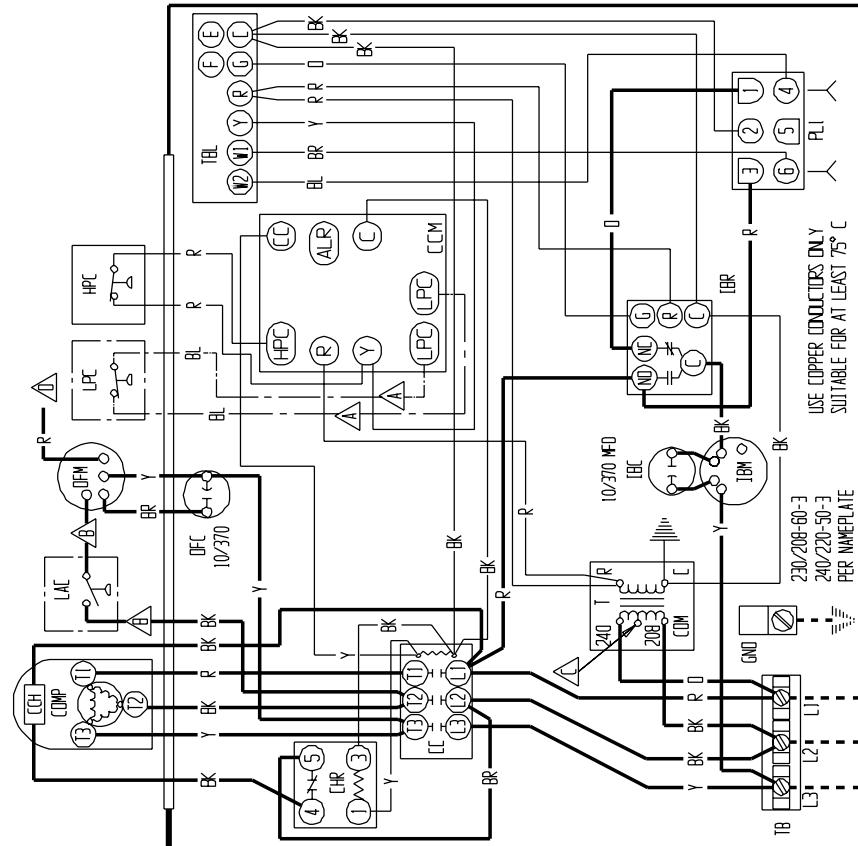
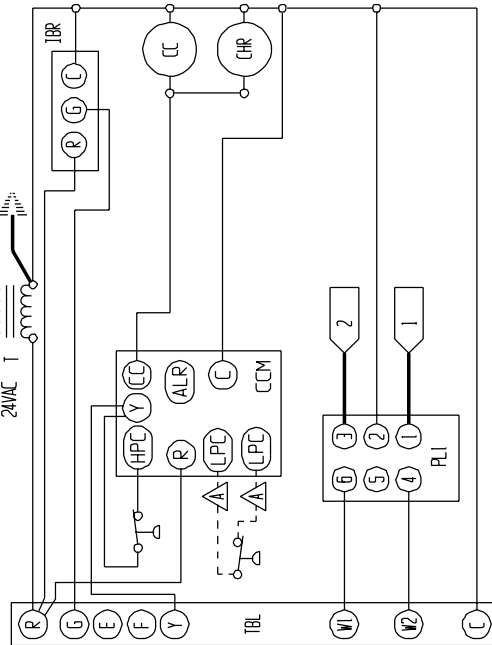
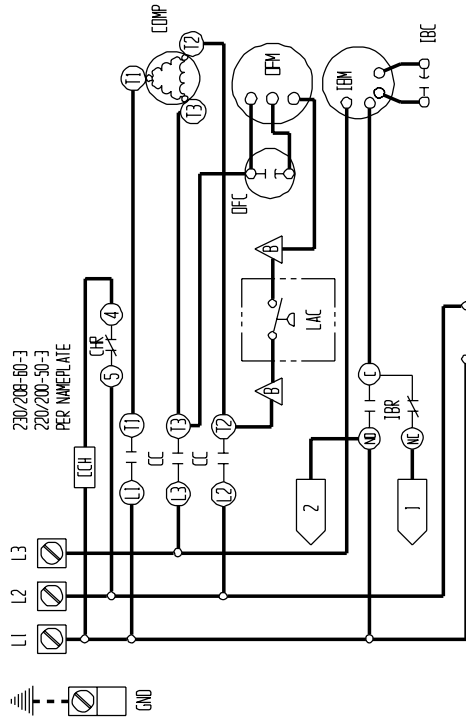

COMPONENT CODE	DESCRIPTION
LAC	LOW AMBIENT CONTROL
LPB	LOW PRESSURE BYPASS
LPC	LOW PRESSURE CONTROL
DFC	LOW PRESSURE CONTROL MODULE
DFM	OUTDOOR FAN CAPACITOR
DFM	OUTDOOR FAN MOTOR
PLI	PLUG #1
T	TRANSFORMER
TB	TERMINAL BLOCK
TBL	LOW VOLTAGE TERMINAL BLOCK
CC	COMPRESSOR CONTACTOR
CCH	CRANKCASE HEATER
CCM	COMPRESSOR CONTROL MODULE
CHR	CRANKCASE HEATER RELAY
CCM	COMPRESSOR
DCC	DUAL CAN CAPACITOR
GND	EQUIPMENT GROUND
HPC	HIGH PRESSURE CONTROL
IBC	INDOOR BLOWER CAPACITOR
IBM	INDOOR BLOWER MOTOR
IBR	INDOOR BLOWER RELAY

NOTE: RED WIRE TO 208V TAP FOR 208V OPERATION. RED WIRE FOR 50 HZ. OPERATION ONLY.

FACTORY STD.	FIELD	OPTIONAL
HIGH VOLTAGE	-----	-----
LOW VOLTAGE	-----	-----
ACCESSORY	-----	-----

BLACK	BROWN	RED	ORANGE	YELLOW	GREEN	BLUE	WHITE	VIOLET	PURPLE	PINK	TAN
BK	BR	R	O	Y	G	BL	W	V	P	PK	T

BARCO MFG. CO.
4064-214 A

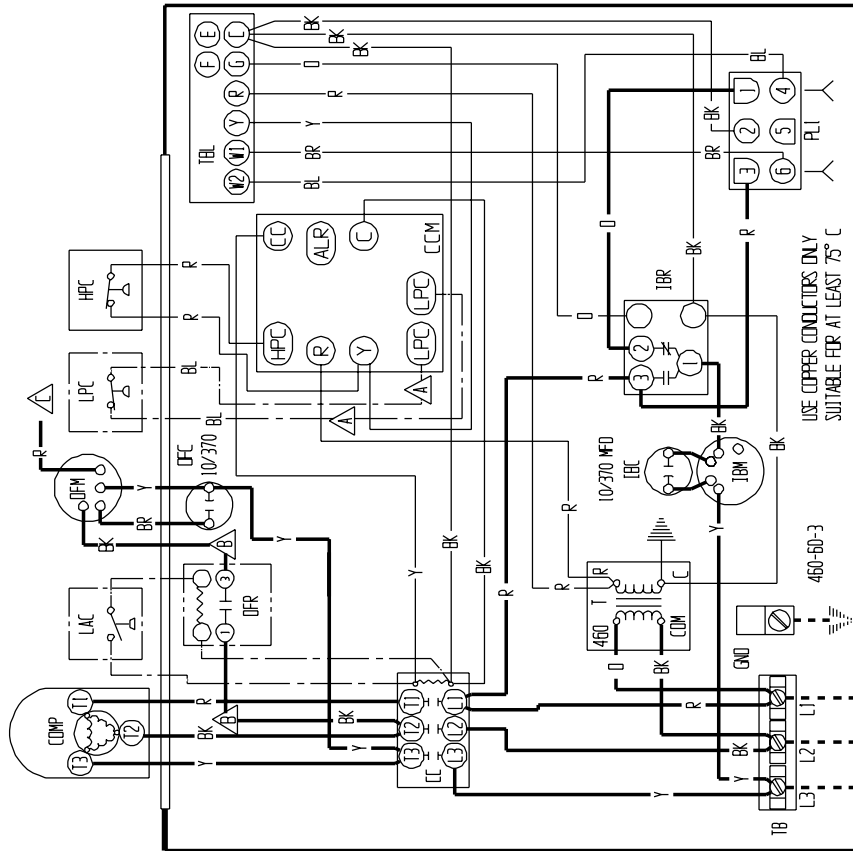
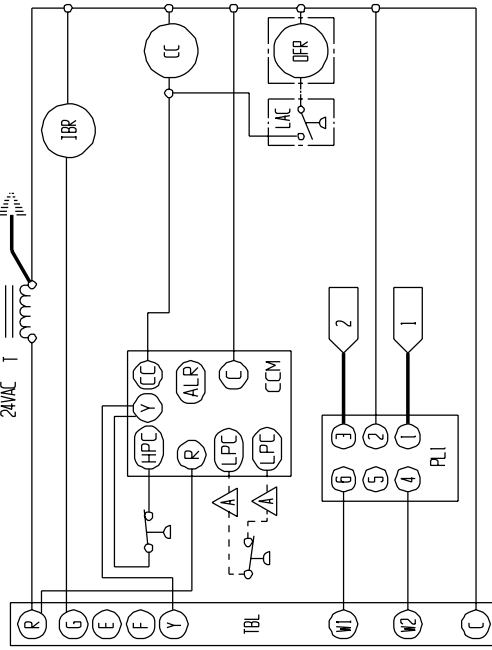
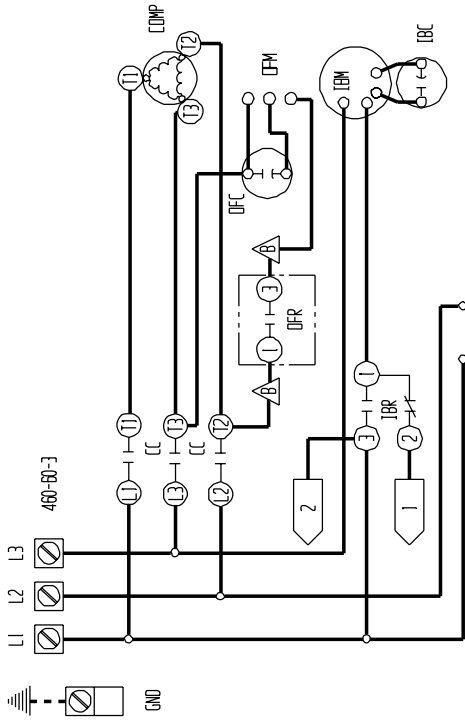

COMPONENT CODE	COMPONENT CODE	COMPONENT CODE
CC	COMPRESSOR CONTACTOR	LOW PRESSURE BYPASS
COM	COMPRESSOR CONTROL MODULE	LPC
COMP	COMPRESSOR	DFC
DCC	DUAL CAN CAPACITOR	DFM
END	EQUIPMENT GROUND	PLI
HPC	HIGH PRESSURE CONTROL	T
IBC	INDOOR BLOWER CAPACITOR	TB
IBM	INDOOR BLOWER MOTOR	TBL
IBR	INDOOR BLOWER RELAY	
LAC	LOW AMBIENT CONTROL	

FACTORY STD.	FIELD	OPTIONAL
HIGH VOLTAGE	---	---
LOW VOLTAGE	---	---
ACCESSORY	---	---

▲ Labeled wires connect if no options used. ▲ RED WIRE FOR 50 HZ. OPERATION ONLY

BARND MFG. CO.
4064-314 B

COLOR CODE	TAN	PINK	LAVENDER
Y	PK	L	
YELLOW	V	VIOLET	PURPLE
GREEN	(PR)	GRAY	SLATE
BLUE	BY	WHITE	
BLACK	BL		
BROWN	BR		
RED	R		
ORANGE	O		

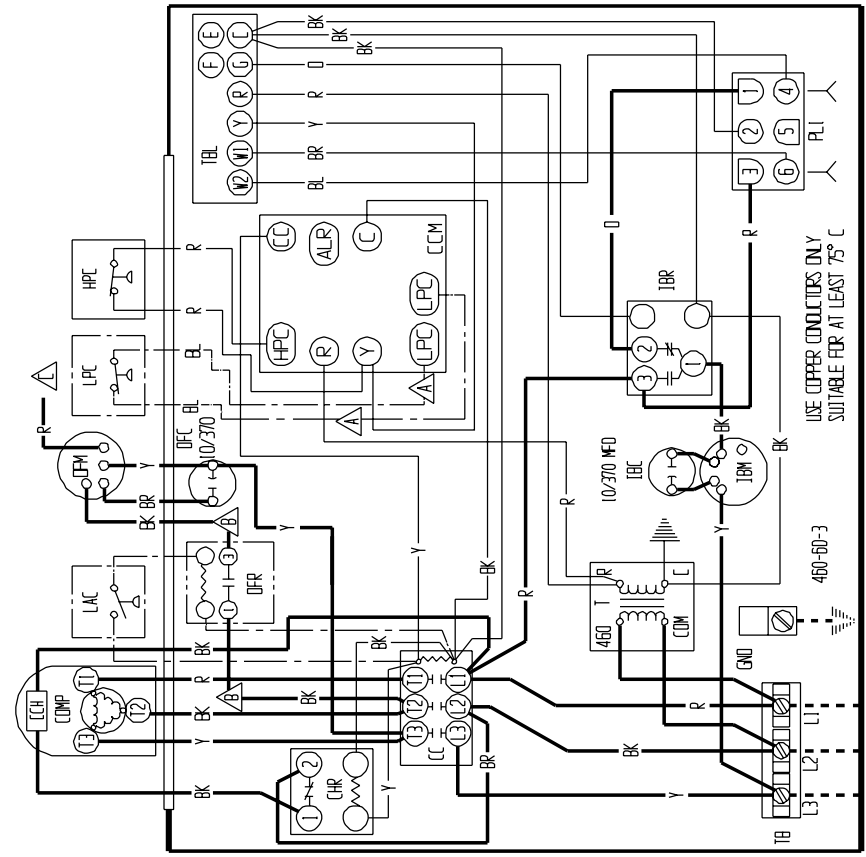
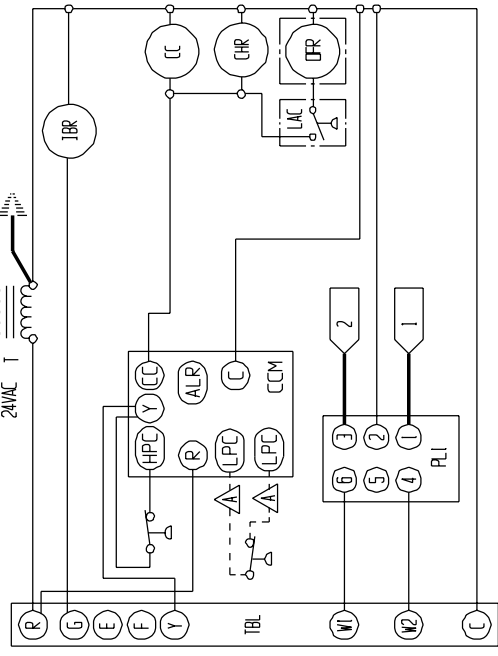
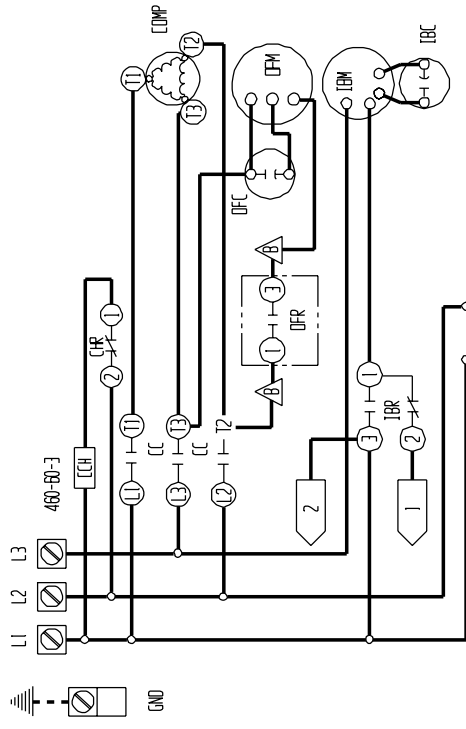

COMPONENT CODE	LOW AMBIENT CONTROL	LOW PRESSURE BYPASS	LOW PRESSURE CONTROL	OUTDOOR FAN CAPACITOR	OUTDOOR FAN MOTOR	PLUG #1	TRANSFORMER	TERMINAL BLOCK	LOW VOLTAGE TERMINAL BLOCK
LAC	LCH	COMP	LAC	DFC	DFM	PLI	T	TBL	
COMPRESSOR CONTROL MIDDLE									
COMPRESSOR HEATER									
COMPRESSOR HEATER RELAY									
COMPRESSOR									
DUAL CAN CAPACITOR									
EQUIPMENT GROUND									
HIGH PRESSURE CONTROL									
INDOOR BLOWER CAPACITOR									
INDOOR BLOWER MOTOR									
INDOOR BLOWER RELAY									

▲ Labeled wires connect if no options used. ▲ Red wire for 50 Hz. operation only.

FACTORY STD.	FIELD	OPTIONAL
---	---	---
---	---	---
---	---	---
---	---	---

COLOR CODE	Y	G	BL	W	V	(PR)	Y	TAN
BLACK	BK	BK	R	O	YELLOW	Y	Y	PK
BROWN	BR	BR	OR		GREEN	G	GR	L
RED	R	OR	OR		PURPLE	P	PL	
ORANGE	O				GRAY	GY	GR	
					SLATE	SL	SL	

BARD MFG. CO.
4064-315 A