INSTALLATION INSTRUCTIONS

SINGLE PACKAGE AIR CONDITIONERS

MODELS
P1142A3
P1148A1
P1060A1



Bard Manufacturing Company
Bryan, Ohio 43506

*Since 1914...Moving ahead, just
as planned.*

Manual : 2100-324
File: Volume II Tab 10
Date: 01-28-98

© Copyright 1998

Contents

Getting Other Informations and Publications	1
General Instructions	4
Important	4
Shipping Damage	4
General	4
Field-Installed Heater Packages (Optional)	4
Installation	6
Location	6
Typical Installations	6
Condensate Drain Trap	9
Air Filters	9
Wiring – Main Power	10
Wiring – 24V Low Voltage Control Circuit	10
Transformer Taps	10
Thermostats	10
Start Up and Operation	11
Three Phase Scroll Compressor Start Up Information	11
Sequence of Operation	11
Start Up Notes	11
High Pressure Switch and Lockout Relay	11
Service and Troubleshooting	12
Service Hints	12
Pressure Service Ports	12
Refrigerant Charge	12
Fan Blade Settings	12
Suction and Discharge Tube Brazing	12
Pressure Table	13
Wiring Diagrams	14

Figures

Figure 1	Prefabricated Roof Curb Specifications	5
Figure 2	Field Fabricated Curbing	5
Figure 3	Elevated Mounting Platforms	7
Figure 4	Airflow and Service Access Clearances	7
Figure 5	Roof Top Application	8
Figure 6	Slab Mounting at Ground Level	8
Figure 7	Condensate Drain Trap	9
Figure 8	Low Voltage Wiring	10
Figure 9	Fan Blade Setting Dimensions	12
Figure 10	Brazing Diagram	13

Tables

Table 1	Electrical Data	2
Table 2	Optional Field Installed Heater Packages	2
Table 3	Optional Field Installed Heater Table	3
Table 4	Maximum ESP of Operation	4
Table 5	Rated CFM and Rated ESP	6
Table 5A	ESP in Inches H ₂ O	6
Table 6	Air Filter Area and Size	9
Table 7	Thermostat Wire Size	10
Table 8	Wall Thermostat and Subbase Combinations	10
Table 9	Refrigerant Charge	12
Table 10	Pressure Table	13

Getting Other Information and Publications

These publications can help you install the air conditioner or heat pump. You can usually find these at your local library or purchase them directly from the publisher. Be sure to consult current edition of each standard.

National Electrical CodeANSI/NFPA 70

Standard for the InstallationANSI/NFPA 90A
of Air Conditioning and
Ventilating Systems

Standard for Warm AirANSI/NFPA 90B
Heating and Air
Conditioning Systems

Load Calculation forACCA Manual J
Residential Winter and
Summer Air Conditioning

Duct Design for ResidentialACCA Manual D
Winter and Summer Air Conditioning
and Equipment Selection

For more information, contact these publishers:

ACCA — Air Conditioning Contractors of America
1712 New Hampshire Ave. N.W.
Washington, DC 20009
Telephone: (202) 483-9370
Fax: (202) 234-4721

ANSI — American National Standards Institute
11 West Street, 13th Floor
New York, NY 10036
Telephone: (212) 642-4900
Fax: (212) 302-1286

**ASHRAE — American Society of Heating
Refrigerating, and
Air Conditioning Engineers, Incorporated**
1791 Tullie Circle, N.E.
Atlanta, GA 30329-2305
Telephone: (404) 636-8400
Fax: (404) 321-5478

NFPA — National Fire Protection Association
Batterymarch Park
P.O. Box 9101
Quincy, MA 02269-9901
Telephone: (800) 344-3555
Fax: (617) 984-7057

**TABLE 1
ELECTRICAL DATA**

Model	Rated Volts & Phases	Operating Voltage Range	Maximum Unit Amps	①	Minimum Circuit Ampacity	②	③
				Maximum External Fuses or Ckt. Brk. Ckt. A		Field Power Wiring Ckt. A	Ground Wire Size Ckt. A
P1142A3	230/208-1	197 - 253	24.2	45	29	8	10
P1148A1	240/208-1	197 - 253	26.1	50	36	8	10
P1148A1-B	230/208-3	187-253	18.8	35	23	8	10
P1148A1-C	480-3	414-506	8.5	20	13	12	12
P1060A1	230/208-1	197 - 253	33.9	60	42	8	10
P1060A1-B	230/208-3	187 - 253	23.7	45	28	8	10
P1060A1-C	480-3	414 - 506	11.2	20	14	12	12

- ① Maximum time delay fuse or HACR type circuit breaker.
 ② 75 degree C copper wire size, basic unit only.

**TABLE 2
OPTIONAL FIELD INSTALLED HEATER PACKAGES
ONLY TO BE USED WITH THE AIR CONDITIONING MODELS INDICATED**

Heater Package Model No.	Volts and Phase	P1142A3	P1148A1	P1148A1-B	P1148A1-C	P1160A1	P1160A1-B	P1160A1-C
EH5PB-A05	240/1	S	S	A	A	S	A	A
EH5PB-A10		S	S	A	A	S	A	A
EH5PB-A15		S	S	A	A	S	A	A
EH5PB-A20		S	S	A	A	S	A	A
EH5PB-B09	240/3		A	S	A	A	S	A
EH5PB-B15			A	S	A	A	S	A
EH5PB-B18				A	S	A	A	S
EH5PB-C09	480/3		A	A	S	A	A	S
EH5PB-C15			A	A	S	A	A	S
EH5PB-B16				A	A	S	A	A

- S - Standard application - Heater volts and phase same as basic unit
 A - Alternate application - Heater volts and phase different from basic unit

**TABLE 3
OPTIONAL FIELD-INSTALLED ELECTRIC HEATER TABLE**

Heater Pkg. Model No.	Unit Volts Phase	Htr. KW & Capacity @ 240V (or 480V if applicable)		Htr. KW & Capacity @ 208 Volts		@ 240V or 480V as applicable Htr. Amps	Heater Internal Fuses	Circuit B				
		KW	BTUH	KW	BTUH			No. Field Ckts.	Minimum Circuit Ampacity	① Maximum Overcurrent Protection	② Field Power Wiring	③ Ground Wire Size
EH5PB-A05	240/208-1	5	17,100	3.75	12,800	20.8		1	26	30	10	10
EH5PB-A10	240/208-1	10	34,100	7.50	26,000	41.7		1	53	60	6	10
EH5PB-A15	240/208-1	15	51,200	11.25	38,400	62.5	30/60	1	79	80	4	8
EH5PB-A20	240/208-1	20	68,200	15.00	51,200	83.2	60/60	1	104	110	2	6
EH5PB-B09	240/208-3	9	30,700	6.75	23,000	21.7		1	28	30	10	10
EH5PB-B15	240/208-3	15	51,200	11.25	38,400	36.2		1	46	50	8	10
EH5PB-B18	240/208-3	18	61,400	13.50	46,100	43.4		1	55	60	6	10
EH5PB-C09	480/3	9	30,700	6.75	23,000	10.8		1	15	15	14	14
EH5PB-C15	480/3	15	51,200	11.25	38,400	18.0		1	23	25	10	10
EH5PB-C18	480/3	18	61,400	13.50	46,100	21.7		1	28	30	10	10

- ① Time delay fuses or "HACR" type circuit breakers must be used for 60 and smaller sizes. Standard fuses or circuit breakers are suitable for sizes 70 and larger.
- ② Based on wire suitable for 75° C. Other wiring materials must be rated for marked "Minimum Circuit Ampacity" or greater.
- ③ Based upon Table 250-65 of N.E.C. 1993. See electrical data for basic heat pump for Circuit A wiring specification requirements.

IMPORTANT: While this electrical data is presented as a guide, it is important to electrically connect properly size fuses and conductor wires in accordance with the National Electrical Code and all existing local codes.

GENERAL INSTRUCTIONS

IMPORTANT

The equipment covered in this manual is to be installed by trained, experienced service and installation technicians. All duct work, supply and return ducts, must be properly sized for the design air flow requirement of the equipment. ACCA is an excellent guide to proper sizing. All duct work or portions thereof not in the conditioned space should be properly insulated in order to both conserve energy and prevent condensation or moisture damage.

SHIPPING DAMAGE

Upon receipt of equipment, the carton should be checked for external signs of shipping damage. If damage is found, the receiving party must contact the last carrier immediately, preferably in writing, requesting inspection by the carrier's agent.

GENERAL

The refrigerant system is completely assembled and charged. All internal wiring is complete.

The unit is designed for use with or without duct work. Flanges are provided for attaching the supply and return ducts.

These instructions explain the recommended method to install the air cooled self-contained unit and the electrical wiring connections to the unit.

These instructions and any instructions packaged with any separate equipment required to make up the entire heat pump system should be carefully read before beginning the installation. Note particularly "Starting Procedure" and any tags and/or labels attached to the equipment.

While these instructions are intended as a general recommended guide, they do not supersede any national and/or local codes in any way. Authorities having jurisdiction should be consulted before the installation is made.

FIELD INSTALLED HEATER PACKAGES (OPTIONAL)

These packaged heat pumps are manufactured without supplementary electric heaters. Supplementary heaters EH5PE series (to fit P1142A3, P1148A1, and P1160A1) are available for simple, fast, field installation.

A separate field power circuit is required for the supplementary heaters.

IMPORTANT: Refer to Table 4 and 5 when designing duct work for maximum available static pressure with heater installed.

Refer to the electrical data shown on pages 2 and 3 for proper application information on all available heater combinations and what units they can be used with. It also shows the applicable circuit capacities, fuse size, and wire size for each heater combination.

Refer to the installation instructions packed with the heater for details on how to insert it into the basic unit.

TABLE 4
MAXIMUM ESP OF OPERATION

	P1142A3	P1148A1	P1080A1
A00	.50	.50	.50
A05	.50	.50	.50
A10	.50	.50	.50
A15	.40	.50	.50
A20	.40	.50	.50
B00	---	.60	.50
B09	---	.50	.50
B15	---	.50	.50
B18	---	.50	.50
C00	---	.50	.50
C09	---	.50	.50
C15	---	.50	.50
C18	---	.50	.50

**FIGURE 1
 PREFABRICATED ROOF CURB SPECIFICATIONS
 HEAVY GAUGE GALVANIZED WITH WOOD NAILING STRIP, WELDED/LEAKPROOF
 ONE PIECE CONSTRUCTION - READY TO INSTALL.**

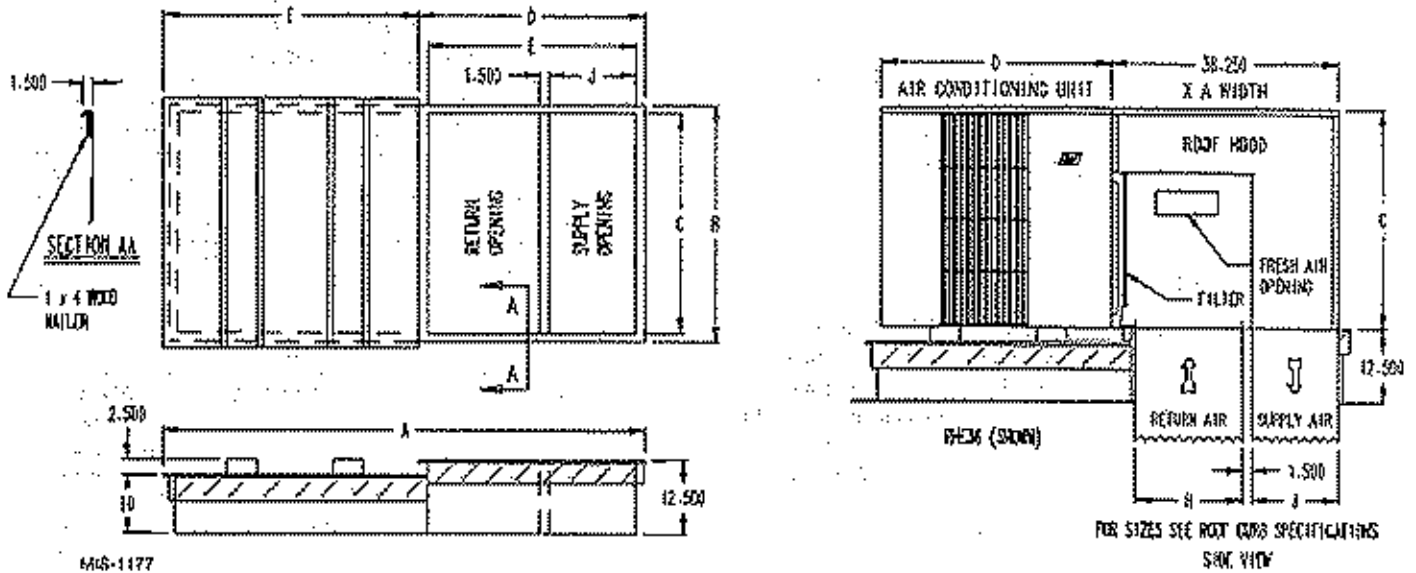

MMS-1177

CURB AND ROOF DETAILS

Roof Curb	A	B	C*	D	E	F	J*	H*	Roof Hood Model	Air Conditioning Units
9042-004	82-3/8	44-1/8	41-1/8	38-3/8	35-3/8	44	14-3/4	19-1/8	RHE60	P1142A3, P1148A1, P1060A1

*Duct Sizing Information
 Return Air Dimension "C" is length
 Return Air Dimension "H" is width

Supply Air Dimension "C" is length
 Supply Air Dimension "J" is width

**FIGURE 2
 FIELD FABRICATED CURBING**

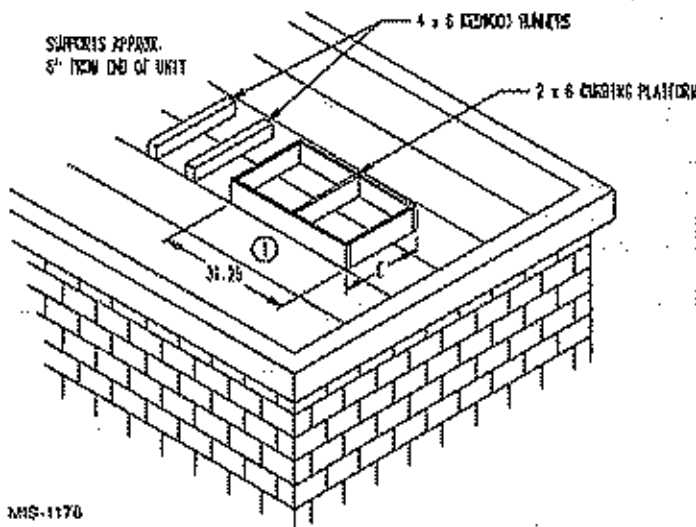

MMS-1178

Roof Hood Model	Unit Model	E
RHE60	P1142A3 P1148A1 P1060A1	44-7/8

① A SEPARATE METAL FLASHING SHOULD BE INSTALLED AROUND WOOD CURBING. CHALK & SEAL ALL JOINTS & WEATHERPROOF.

INSTALLATION

LOCATION

GENERAL

The unit must be located outside, or in a well ventilated area. It must not be in the space being heated or cooled. A sound absorbing material should be considered if the unit is to be installed in such a position or location that might cause transmission of sound or vibration to the living area or adjacent buildings.

SLAB MOUNTING

In areas where winter temperatures *DO NOT* go below 32° F for periods over twelve hours, the unit may be slab mounted at grade level. When installing unit at grade level, install on a concrete slab at least four inches above finished grade level. Slab should have a slope tolerance away from the building structure of at least 1/4 inch per foot, while being level from side to side. Place slab in a location where runoff water from higher ground will not collect around unit. See Figure 3.

A minimum of 18 inches should be provided between the coil inlet and any building surfaces. Provide at least four feet between coil outlet and any building wall, fences or other vertical structures. Provide a minimum of three feet clearance on the service access side of the unit. See Figure 4

ROOF MOUNTING

When a unit is installed in areas where low ambient temperatures or strong winter winds exist, it should be placed for prevailing winter winds are not in direct line with the outdoor coil. If this is not possible, a wind barrier should be constructed. Place barrier 24 inches from the coil inlet side of the unit and in the direction of prevailing winds. Size barrier at least the same height and width as the unit. This may be necessary on ground level installations, also. See Figure 5.

WINTER INSTALLATION BELOW 32°F

In areas where winter conditions go below 32°F for extended periods, the unit must be elevated above the mounting surface to prevent snowfall or ice accumulation from interfering with the operation of the unit. A minimum of twelve inch elevation is recommended, while greater elevation may be required for areas of high snow accumulation. Poured concrete, steel framework, brick, cement block, etc., can be utilized to construct a suitable raised mounting platform. See Figure 6.

DUCT WORK

Refer to Tables 4, 5 and 5A when designing duct work for maximum static pressure available with the specific model and heater package being installed.

TABLE 5
RATED CFM AND
EXTERNAL STATIC PRESSURE (ESP)
WET COIL (COOLING)

Model	Rated CFM	Rated ESP	Recommended Air Flow Range
P1142A3	1400	.20	1260 - 1540 CFM
P1148A1	1550	.40	1400 - 1700 CFM
P1060A1	1700	.20	1530 - 1870 CFM

TABLE 5A

ESP inches H ₂ O	P1142A3 PH11421 Dry / Wet	P1148A1 PH1048 Dry / Wet	P1060A1 PH1060 Dry / Wet
0	1650 / 1625	1950 / 1920	1850 / 1850
.1	1550 / 1525	1860 / 1830	1800 / 1780
.2	1435 / 1400	1780 / 1760	1725 / 1700
.3	1340 / 1310	1680 / 1660	1600 / 1625
.4	1230 / 1210	1580 / 1550	1530 / 1540
.5	1120 / 1100	1500 / 1480	1500 / 1475

TYPICAL INSTALLATIONS

- ROOF MOUNTED** - The unit is mounted on a sturdy base on the roof of the building. Return air to the unit is brought through a single return grille (grilles with built-in filters are best since they enable easy access for filter changing). Return air ducts are attached to the lower section of the front panel. Supply air is brought from the unit to attic duct work or to a furred down hall. Supply air duct is attached to the top of the front panel.

CAUTION: All outdoor duct work must be thoroughly insulated and weatherproofed. All attic duct work must be thoroughly insulated. Two inch thick insulation with suitable vapor barrier is recommended for both outdoor and attic runs.

In roof top installation, as in all installations, the air conditioner must be level from side to side. However, the unit should have a pitch along the length to assure complete external drainage of precipitation and of defrost condensate.

- CRAWL SPACE** - Duct work installed in crawl space must be well insulated and provided with a vapor barrier. In addition, the crawl space must be thoroughly ventilated and provided with a good vapor barrier as a ground cover. It is most desirable to install the unit will be outdoors rather than inside the crawl space, so that it will be readily accessible for service.

**FIGURE 3
ELEVATED MOUNTING PLATFORMS**

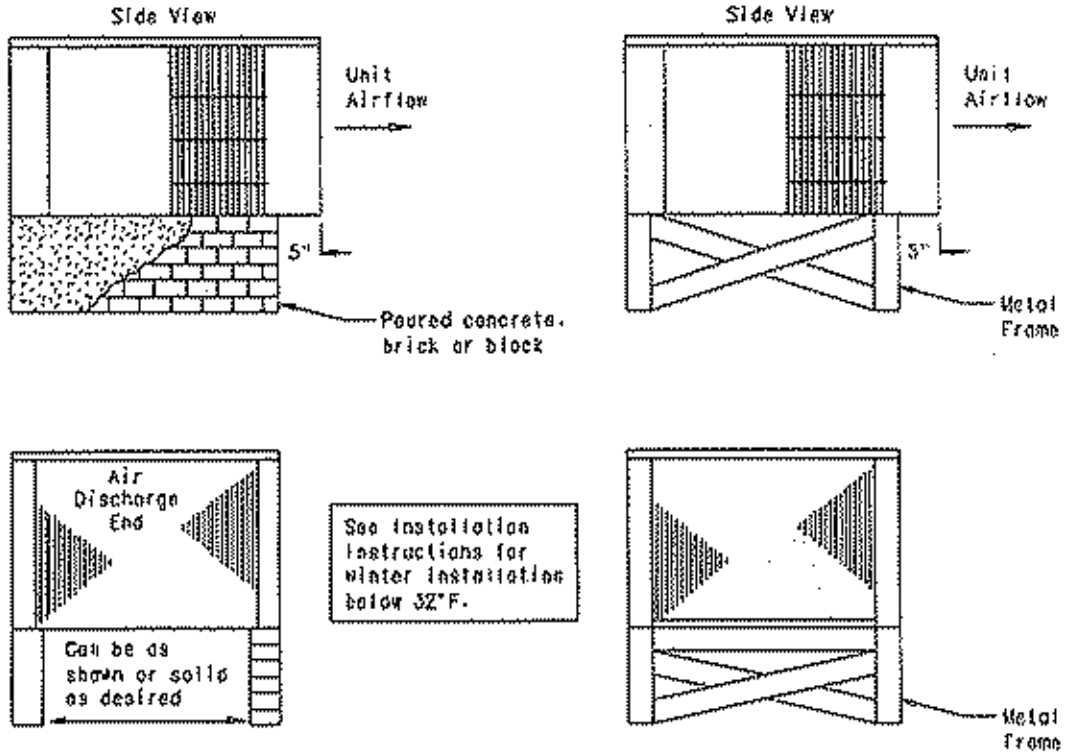

**FIGURE 4
AIRFLOW and SERVICE ACCESS CLEARANCES**

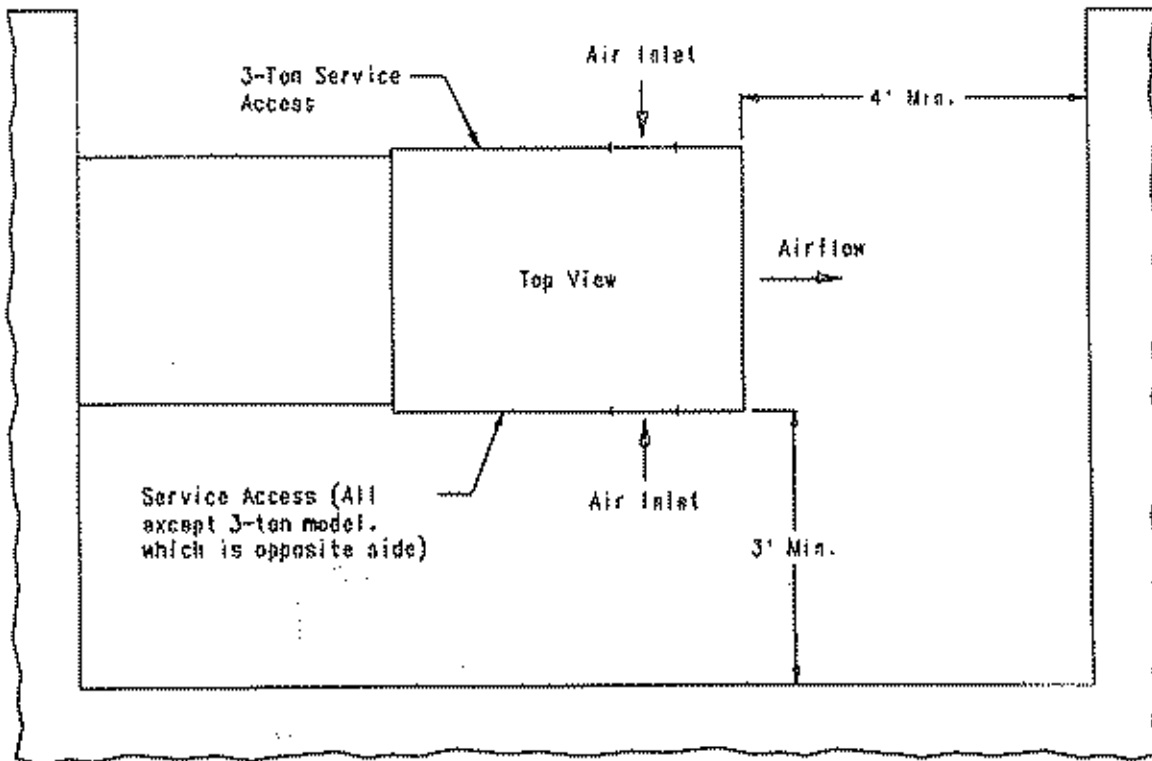
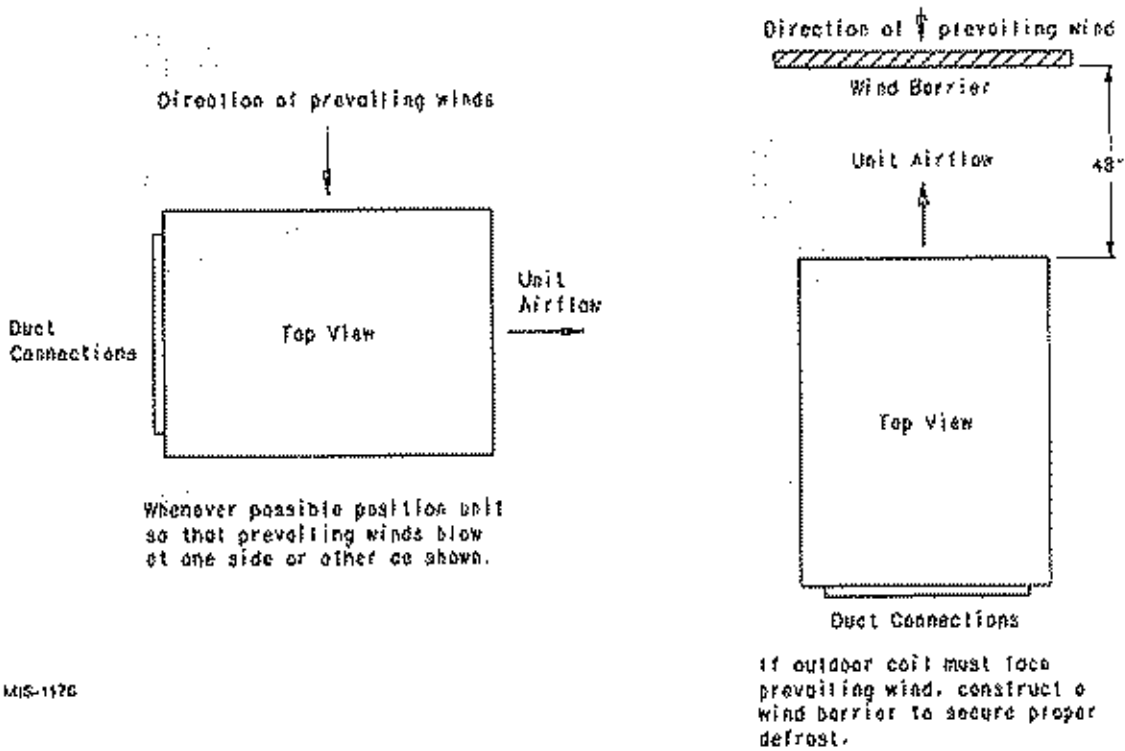
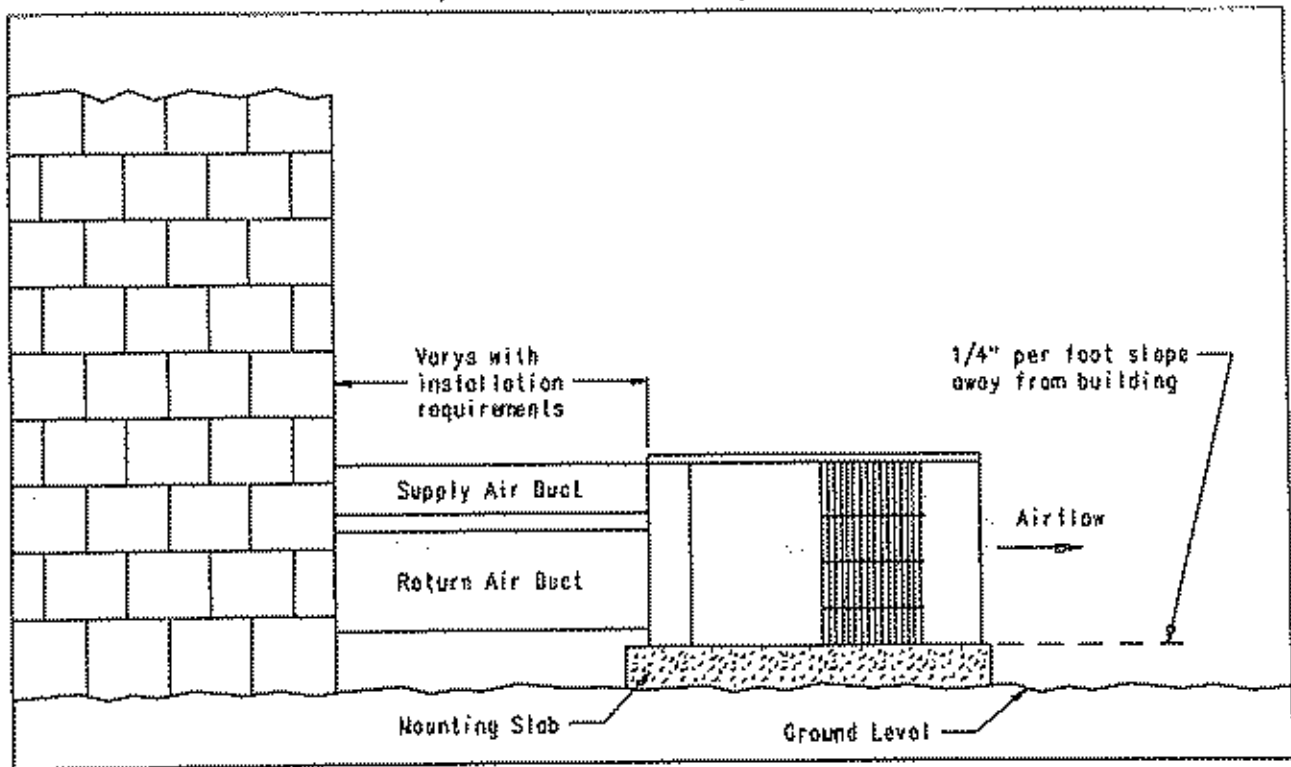

FIGURE 5
ROOF TOP APPLICATION
 (May also be required for ground level installations.)



MIS-1170

FIGURE 6
SLAB MOUNTING AT GROUND LEVEL
 (Above 32° F Outside Temperature)



MIS-1104

3. **SLAB MOUNTED AT GROUND LEVEL** – This type installation is ideal for homes with a slab floor construction where a roof mounted unit is not desired. The supply and return duct work can be run through a furred closet space.
4. **THROUGH THE WALL** – This type installation requires a suitable framework to be fabricated capable of withstanding the unit weight. Normally the unit will be insulated so as to minimize supply and return duct work.
5. **OTHER INSTALLATIONS** – Many other installations are possible with the packaged air conditioner. No matter what the installation, always consider the following facts:
 - A. Insure that the discharge air is not obstructed in any way so as to cause operation difficulties.
 - B. The indoor coil drain pan is equipped with a coupling that must be piped through a condensate drain trap to a suitable drain.
 - C. Always mount the unit in such a position that it may be easily reached for servicing and maintenance.
 - D. Insure that the unit is clear so that proper air flow over the outdoor coil will be maintained.

If this unit is operated in cooling below a 65° outdoor ambient temperature, the installation of low ambient controls (CMA-6) to unit is required.

CONDENSATE DRAIN TRAP

It is very important to provide a trap in the condensate drain line to allow a positive liquid seal in the line and assure correct drainage from the coil condensate pan.

Install condensate drain trap shown in Figure 7. Use drain connection size or larger. Do not operate unit without trap. Unit must be level or slightly inclined toward drain. With a

trap installed on a unit located in an unconditioned area, water in the trap may freeze. It is recommended that the trap material be of a type that will allow for expansion of water when it freezes.

AIR FILTERS

Air filters for the return air side of the system are not provided as part of these models, and must be field supplied and installed as part of the final installation.

Prior thought should be given to return air location and placement of the air filter(s). The air filter(s) must be of adequate size and readily accessible to the operator of the equipment. Filters must be adequate in size and properly maintained for proper operation. If this is not done, excessive energy use, poor performance, and multiple service problems will result. *It is impossible to oversize air filters.* Generous sizing will result in cleaner air and coils as well as lower operating costs and extend the time between required changes. Table 6 shows minimum filter areas and recommended filter sizes. Actual filter sizes can vary with the installation due to single or multiple returns utilizing a filter/grille arrangement or being placed immediately ahead of the indoor coil face in the return air duct.

TABLE 6

Model	Minimum Filter Areas	Recommended Size
P1142A3 P1148A1 P1080A1	608 square inches (4.62 square feet)	(2) 16 x 20 x 1

NOTE: If roof hood accessory is to be used, information on air filters may be found under that heading in this manual. Air filters are supplied as part of that package.

FIGURE 7
CONDENSATE DRAIN TRAP

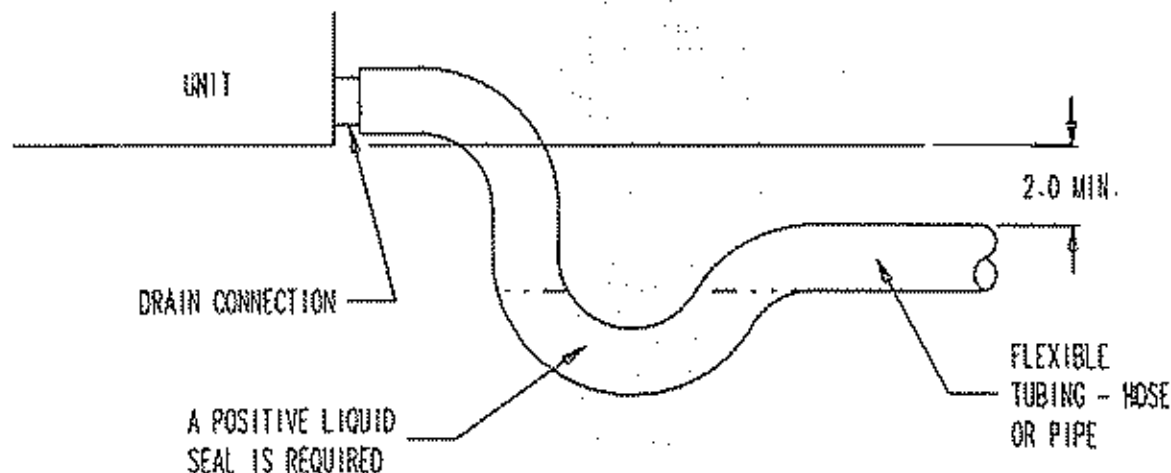

WIRING – MAIN POWER

Refer to the unit rating plate for wire sizing information and maximum fuse size. Each outdoor unit is marked with a "Minimum Circuit Ampacity". This means that the field wiring used must be sized to carry that amount of current. If field installed heaters are added to the basic unit, a second separate power supply circuit will be required. The heater rating plate located adjacent to the basic unit rating plate will show the appropriate circuit ampacity fuse size, etc. (Also see "Electrical Data" on pages 2 and 3.) *All models are suitable for connection with copper wire only.* These instructions must be adhered to. Refer to the National Electrical Code for complete current carrying capacity data on the various insulation grades of wiring material.

The electrical specifications on page 2 and 3 lists fuse and wire sizes (75°F copper) for all models including the most commonly used heater sizes.

The unit rating plate lists a "Maximum Time Delay Fuse" or "HACR" type circuit breaker that is to be used with the equipment. The correct size must be used for proper circuit protection and also to assure that there will be no nuisance tripping due to the momentary high starting current of the compressor.

WIRING – 24V LOW VOLTAGE CONTROL CIRCUIT

Five (5) wires should be run from thermostat subbase to the 24V terminal board in the unit. A five conductor, 18 gauge copper, color-coded thermostat cable is recommended. The connection points are shown in Figure 8.

THERMOSTATS

See specific wiring information for the different models, heater KWs, and voltages on pages 14 through 17.

TABLE 6
WALL THERMOSTAT and SUBBASE COMBINATIONS

Thermostat	Subbase	Predominant Feature
8403-019 ② (T874C1760)	8404-012 (Q874A1001)	1 stage cool, 2 stage heat System: heat-auto-cool Fan: on-auto
8403-002 ① (T87F3111)	8403-003 (Q530A1220)	1 stage heat, 1 stage cool System: heat-off-cool Fan: on-auto
8403-000 (1F56-318)	*****	1 stage heat, 1 stage cool System: heat-off-cool Fan: on-auto

① No automatic changeover position – must be manually placed in heat or cool. Reversing valve remains energized at all times system switch is in heat position (except during defrost cycle). No pressure equalization noise when thermostat is satisfied on either heating or cooling.

② Allows thermostat to control both heating and cooling operation when set in "AUTO" position. Reversing valve de-energizes at end of each "ON" heating cycle.

IMPORTANT NOTE: Only the thermostat and subbase combinations as shown above will work with this equipment. The thermostat and subbase **MUST** be matched, and correct operation can be assured only by proper selection and application of these parts.

FIGURE 8 – LOW VOLTAGE WIRING

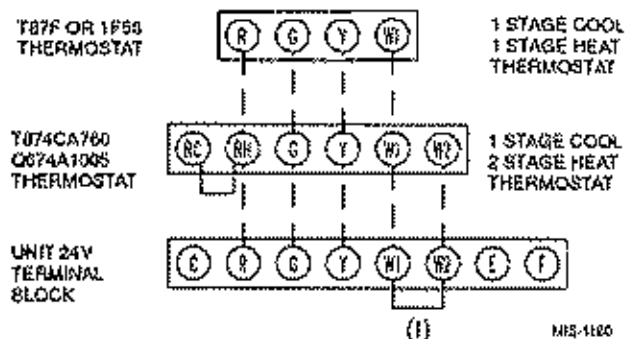

(1) Remove jumper for 2 stage electric heat on units with 15 or more KW

TABLE 7 – THERMOSTAT WIRE SIZE

Transformer VA	FLA	Wire Gauge	Maximum Distance in Feet
55	2.3	20	45
		18	60
		16	100
		14	160
		12	250

TRANSFORMER TAPS

230/208V, 1 phase and 3 phase equipment employ dual primary voltage transformers. All equipment leaves the factory wired on 240V tap. For 208V operation, reconnect from 240V to 208V tap. The acceptable operating voltage range for the 240 and 208V taps are:

TAP	RANGE
240	253 – 216
208	220 – 187

NOTE: The voltage should be measured at the field power connection point in the unit and while the unit is operating at full load (maximum amperage operating condition).

START UP AND OPERATION

THREE PHASE SCROLL COMPRESSOR START UP INFORMATION

Scroll compressors, like several other types of compressors, will only compress in one rotational direction. Direction of rotation is not an issue with single phase compressors since they will always start and run in the proper direction.

However, three phase compressors will rotate in either direction depending upon phasing of the power. Since there is a 50-50 chance of connecting power in such a way as to cause rotation in the reverse direction, verification of proper rotation must be made. Verification of proper rotation direction is made by observing that suction pressure drops and discharge pressure rises when the compressor is energized. Reverse rotation also results in an elevated sound level over that with correct rotation, as well as, substantially reduced current draw compared to tabulated values.

Verification of proper rotation must be made at the time the equipment is put into service. If improper rotation is corrected at this time there will be no negative impact on the durability of the compressor. However, reverse operation for over one hour may have a negative impact on the bearing due to oil pump out.

NOTE: *If compressor is allowed to run in reverse rotation for several minutes the compressor's internal protector will trip.*

All three phase ZR*3 compressors are wired identically internally. As a result, once the correct phasing is determined for a specific system or installation, connecting properly phased power leads to the same Fusite terminals should maintain proper rotation direction.

The direction of rotation of the motor may be changed by reversing any two line connections to the unit.

SEQUENCE OF OPERATION

COOLING - Circuit R-Y makes at thermostat pulling in compressor contactor starting the compressor and outdoor motor. The G (indoor motor) circuit is automatically completed on any call for cooling operation, or can be energized by manual fan switch on subbase for constant air circulation.

HEATING - A circuit R-W1 is completed on each heating cycle energizing electric heat if so equipped.

START UP NOTES

For improved start up performance, wash the indoor coil with dishwasher detergent

HIGH PRESSURE SWITCH AND LOCKOUT RELAY

The air conditioners are equipped with an auto reset high pressure switch and lockout relay. The lockout relay may be reset by turning the thermostat to off or satisfying the thermostat.

SERVICE AND TROUBLESHOOTING

SERVICE HINTS

1. Caution homeowner to maintain clean air filters at all times. Also, not to needlessly close off supply and return air registers. This reduces air flow through the system which shortens equipment service life as well as increasing operating costs.
2. Check all power fuses or circuit breakers to be sure that they are the correct rating.
3. Periodic cleaning of the outdoor coil to permit full and unrestricted airflow circulation is essential.

PRESSURE SERVICE PORTS

High and low pressure service ports are installed on all units so that the system operating pressures can be observed. Pressure tables can be found in Table 10 in this manual covering all models on cooling cycle. It is imperative to match the correct pressure table to the unit by model number.

REFRIGERANT CHARGE

The correct system R-22 charge is shown on the unit rating plate. Optimum unit performance will occur with a refrigerant charge resulting in a suction line temperature (6" from compressor) as shown in Table 9.

TABLE 9

Model	Rated Airflow	95 Degree F OD Temperature	82 Degree F OD Temperature
P1142A3	1400	57 - 59	58 - 60
P1148A1	1550	55 - 57	59 - 61
P0160A1	1700	47 - 49	54 - 56

The above suction line temperatures are based upon 80°F dry bulb/67°F wet bulb (60% RH) temperature and rated airflow across the evaporator during cooling cycle.

FAN BLADE SETTINGS

Shown in Figure 9 are the correct fan blade setting dimensions for proper air delivery across the outdoor coil.

Any service work requiring removal or adjustment in the fan and/or motor area will require that the dimensions below be checked and blade adjusted in or out on the motor shaft accordingly.

FIGURE 9
FAN BLADE SETTING DIMENSIONS

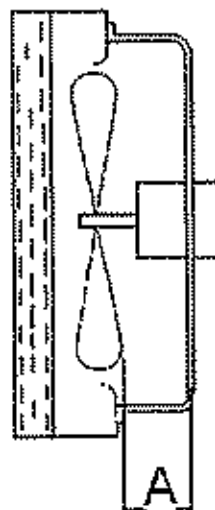

Model	Dimension A
P1142A3	1.75"
P1148A1	1.75"
P1060A1	1.75"

SUCTION AND DISCHARGE TUBE BRAZING

Compliant Scroll compressors have copper plated steel suction and discharge tubes. These tubes are far more rugged and less prone to leaks than copper tubes used on other compressors. Due to different thermal properties of steel and copper, brazing procedures may have to be changed from those commonly used.

- To disconnect: heat joint Areas 2 and 3 slowly and uniformly until braze material softens and the tube can be pulled out of suction fitting. (See Figure 10.)
- To connect:
 - Recommended brazing materials: silfos with minimum 5% silver or silver braze material with flux.
 - Reinsert tube into fitting.
 - Heat tube uniformly in Area 1 moving slowly to Area 2. When joint reaches brazing temperature, apply brazing material. (See Figure 10.)
 - Heat joint uniformly around the circumference to flow braze material completely around the joint.
 - Slowly move torch into Area 3 to draw braze material into joint. (See Figure 10.)
 - Do not overheat joint.

**FIGURE 10
BRAZING DIAGRAM**

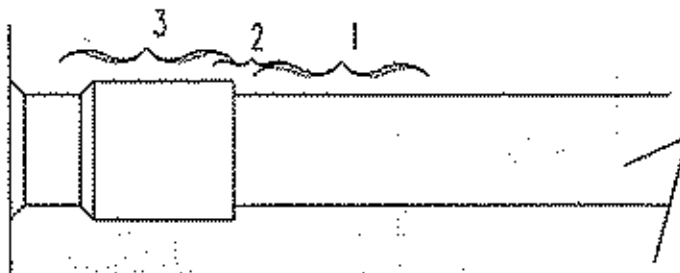
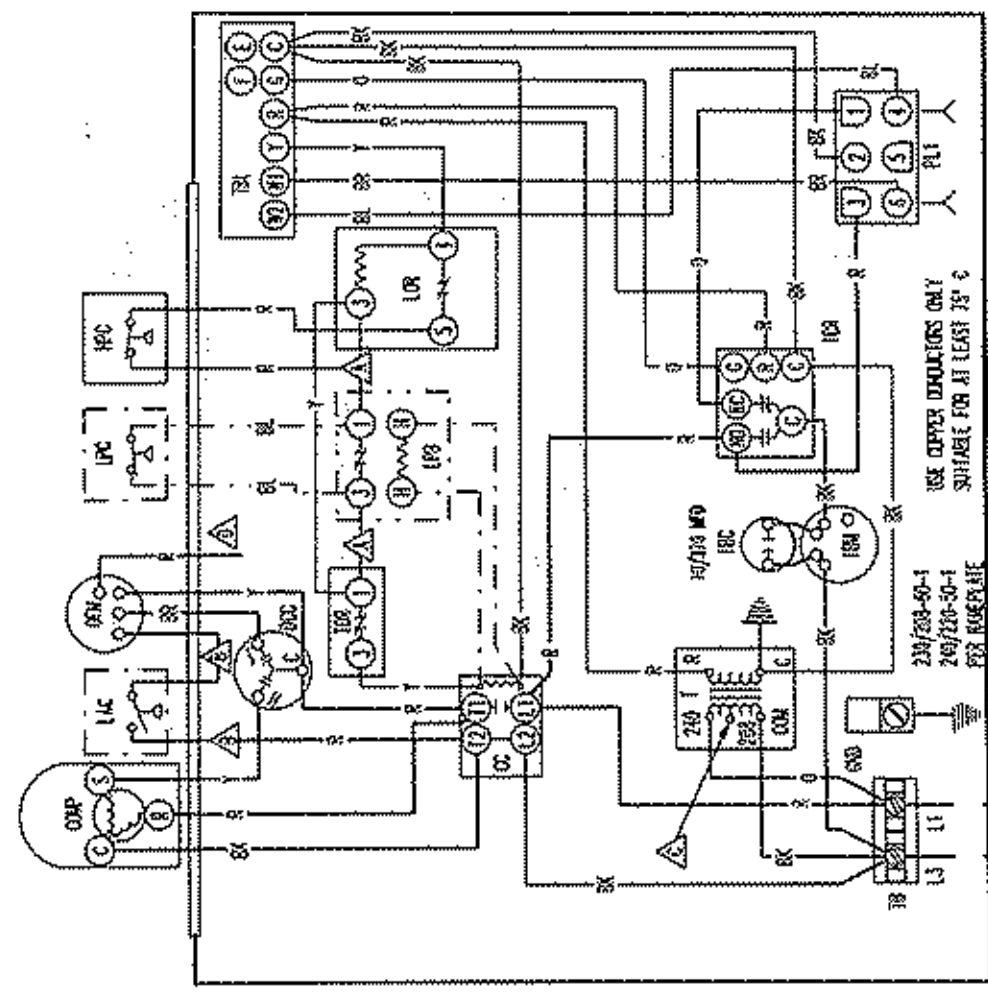
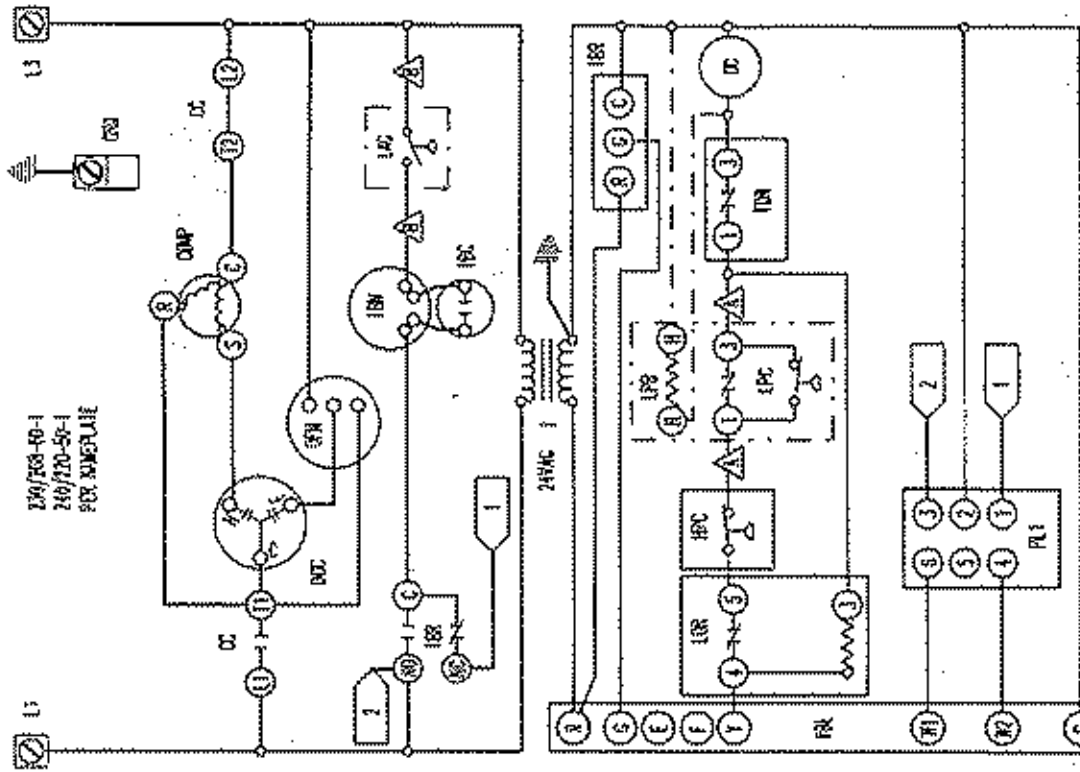

**TABLE 10
PRESSURE TABLE**

COOLING

Air Temperature Entering Outdoor Coil Degrees F

Model	Return Air Temperature	Pressure	75	80	85	90	95	100	105	110	115
P1142A3	75 deg. DB 62 deg. WB	Low Side	70	72	76	77	78	79	80	81	82
		High Side	208	223	239	254	271	286	305	324	342
	80 deg. DB 67 deg. WB	Low Side	75	77	80	82	84	85	96	87	88
		High Side	213	229	245	261	278	295	313	332	351
	85 deg. DB 72 deg. WB	Low Side	81	83	86	88	90	91	92	94	95
		High Side	220	237	254	270	288	305	324	344	363
P1148A1	75 deg. DB 62 deg. WB	Low Side	73	74	75	76	78	79	80	81	82
		High Side	203	217	231	246	264	278	294	312	330
	80 deg. DB 67 deg. WB	Low Side	78	79	81	82	83	84	86	87	88
		High Side	208	222	237	252	268	285	302	320	338
	85 deg. DB 72 deg. WB	Low Side	83	85	87	88	87	91	92	93	94
		High Side	215	230	245	261	273	295	313	331	350
P1060A1	75 deg. DB 62 deg. WB	Low Side	65	66	68	69	70	72	74	75	76
		High Side	214	230	247	264	284	299	318	336	355
	80 deg. DB 67 deg. WB	Low Side	69	71	72	74	76	77	79	80	82
		High Side	219	236	253	271	289	307	326	345	364
	85 deg. DB 72 deg. WB	Low Side	74	76	78	79	81	83	85	86	88
		High Side	227	244	262	280	298	318	337	357	377



WIRE	CONNECTOR	WIRE NO.
210/201	82/10 5/0	852-68
210/201	82/10 1/0	852-68

COMPONENT CODE	DESCRIPTION
OC	COMPRESSOR CONTACTOR
OAP	COMPRESSOR
OC	START CAPACITOR
OC	START WINDING
OC	START WINDING CONTROL
OC	START WINDING MOTOR
OC	START WINDING RELAY
OC	START WINDING CONTROL
OC	LOCK UP RELAY
OC	LOW PRESSURE SWITCH RELAY
OC	LOW PRESSURE OVERHEAT
OC	SHOCK FAN CAPACITOR
OC	SHOCK FAN MOTOR
OC	PLUG FI
OC	TRANSFORMER
OC	TEMPERATURE BLOCK
OC	LOW VOLTAGE THERMAL BLOCK
OC	THE RELAY RELAY

USE RED WIRE TO 200V 120V 240V OPERATION **Δ** RED WIRE FOR 50 Hz OPERATION ONLY

USED WIRE CORRECT IF NO OTHERS USED. **Δ**

WIRE CODE			
Y	ORANGE	GREEN	RED
1	2	3	4
5	6	7	8
9	10	11	12
13	14	15	16
17	18	19	20
21	22	23	24
25	26	27	28
29	30	31	32
33	34	35	36
37	38	39	40
41	42	43	44
45	46	47	48
49	50	51	52
53	54	55	56
57	58	59	60
61	62	63	64
65	66	67	68
69	70	71	72
73	74	75	76
77	78	79	80
81	82	83	84
85	86	87	88
89	90	91	92
93	94	95	96
97	98	99	100

WIRE	CONNECTOR	WIRE NO.
210/201	82/10 5/0	852-68
210/201	82/10 1/0	852-68

WIRE	CONNECTOR	WIRE NO.
210/201	82/10 5/0	852-68
210/201	82/10 1/0	852-68

BASED MFC. CO.
4064-116 B

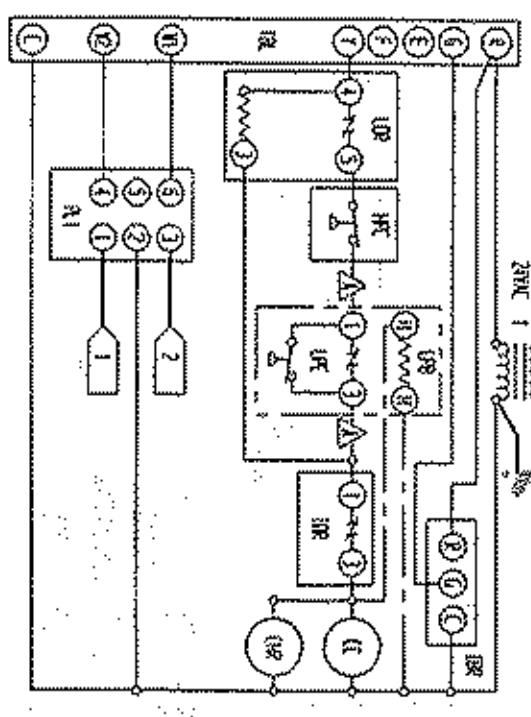
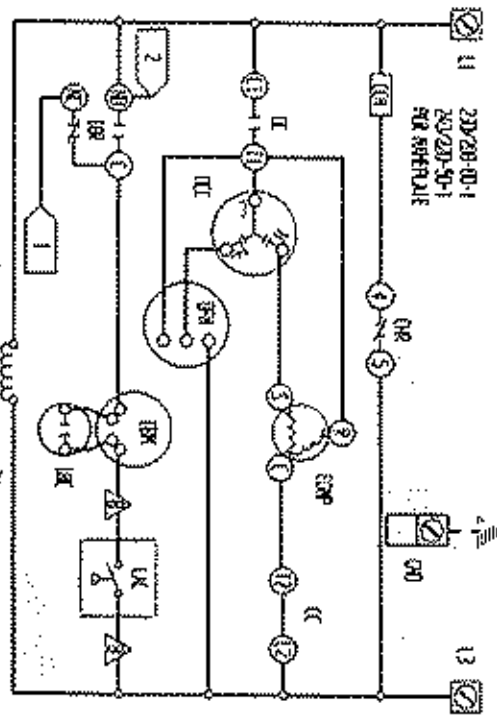
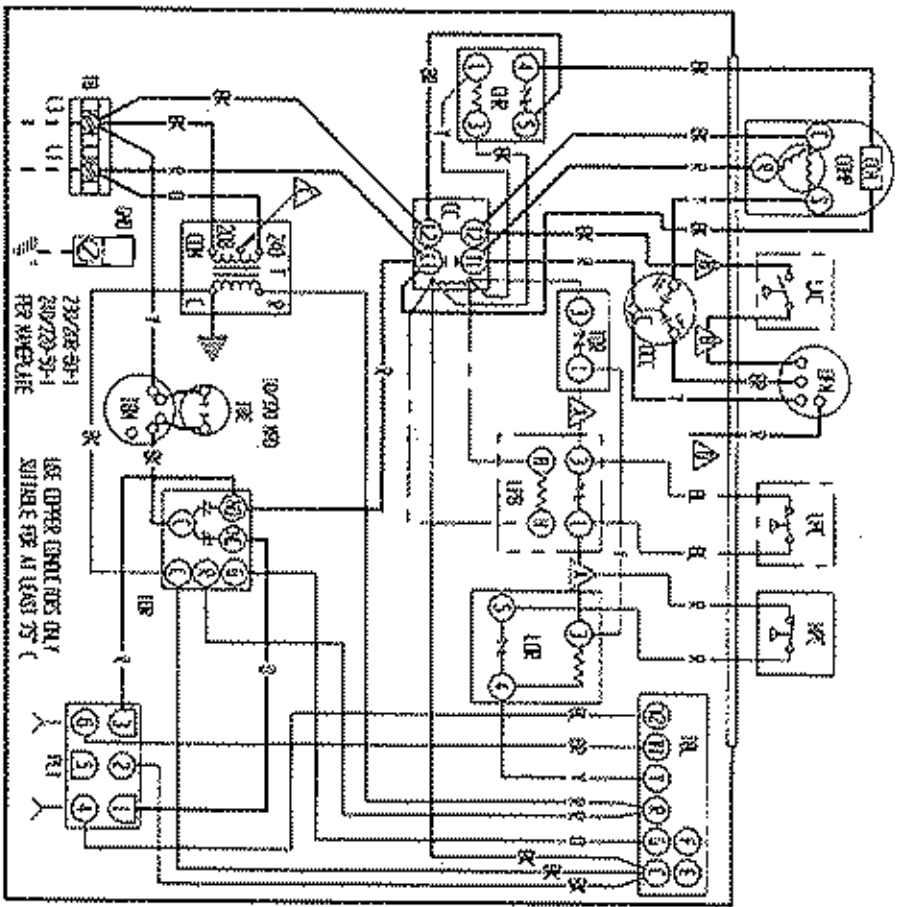

LAMPEN (LIT)	
E	EMPRESSOR QUAKESP
EU	EMPISSOR QUAKESP
EC	EMPISSOR QUAKESP
ED	EMPISSOR QUAKESP
EE	EMPISSOR QUAKESP
EF	EMPISSOR QUAKESP
EG	EMPISSOR QUAKESP
EH	EMPISSOR QUAKESP
EI	EMPISSOR QUAKESP
EJ	EMPISSOR QUAKESP
EK	EMPISSOR QUAKESP

LAMPEN (LIT)	
L1	230/230-50-1
L2	230/230-50-1
L3	230/230-50-1
L4	230/230-50-1
L5	230/230-50-1
L6	230/230-50-1
L7	230/230-50-1
L8	230/230-50-1
L9	230/230-50-1
L10	230/230-50-1
L11	230/230-50-1
L12	230/230-50-1

LAMPEN (LIT)	
L1	230/230-50-1
L2	230/230-50-1
L3	230/230-50-1
L4	230/230-50-1
L5	230/230-50-1
L6	230/230-50-1
L7	230/230-50-1
L8	230/230-50-1
L9	230/230-50-1
L10	230/230-50-1
L11	230/230-50-1
L12	230/230-50-1

4054-117 A

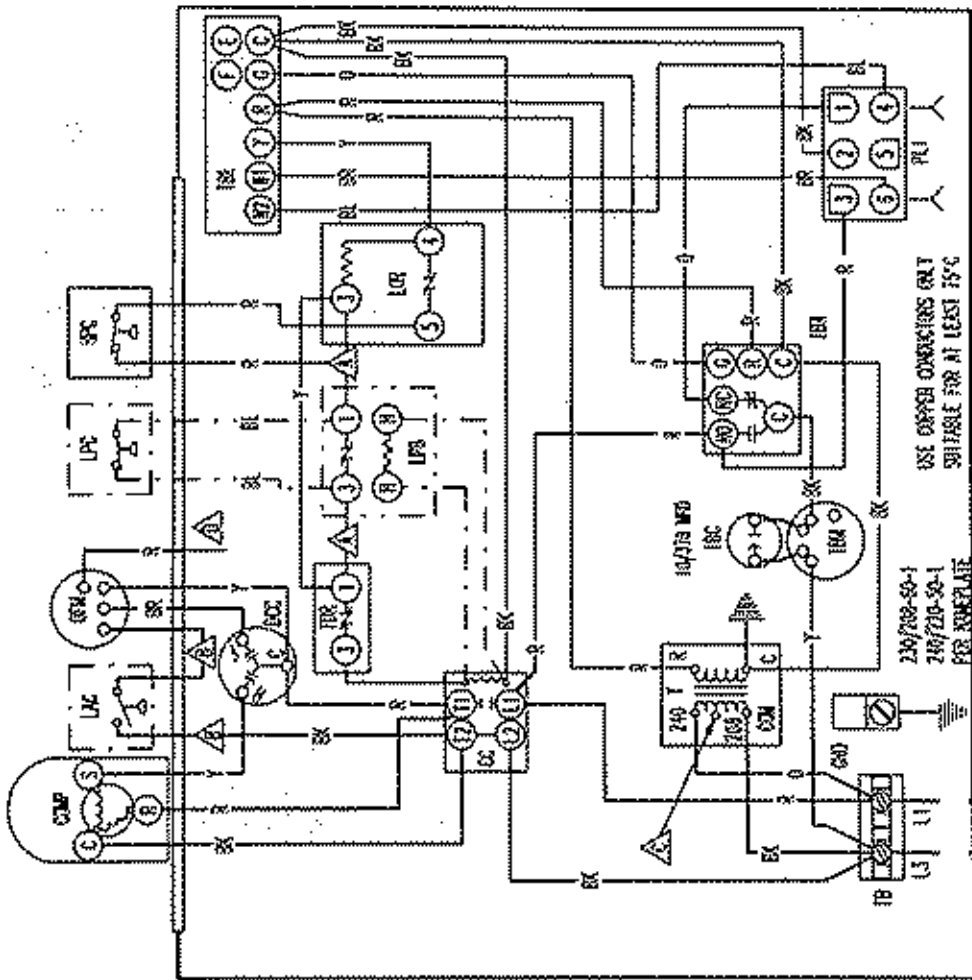
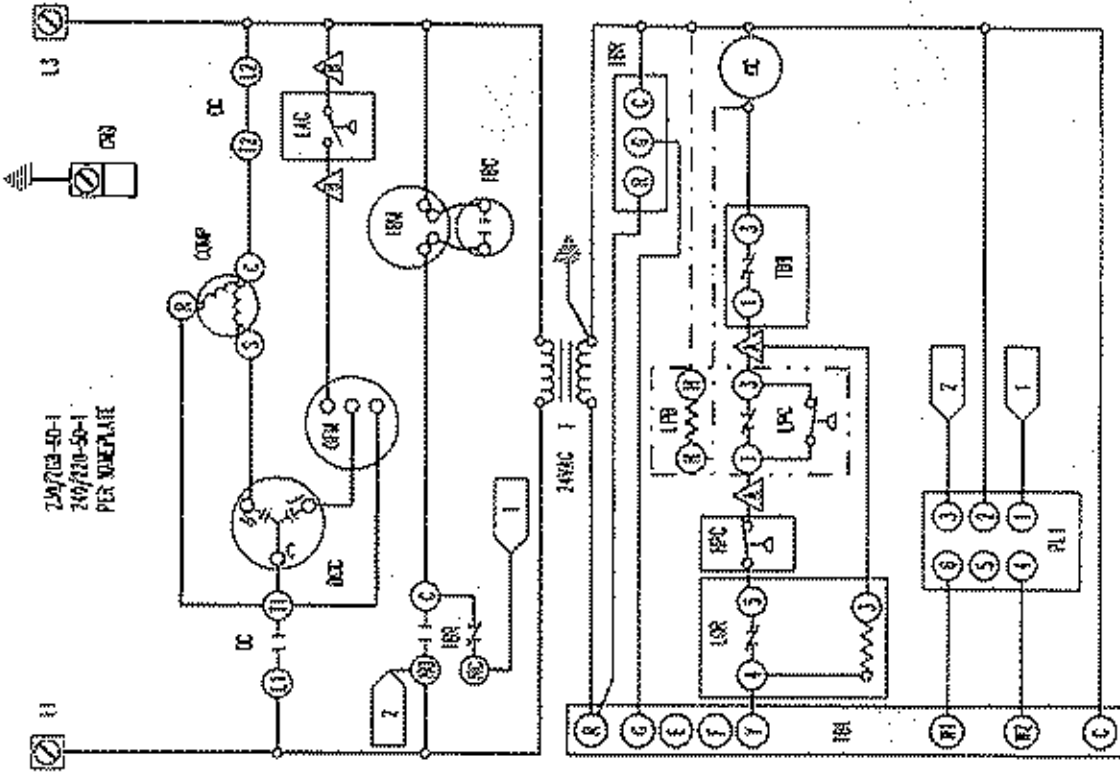

COMPONENT DOC	COMPONENT DOC	LOW PRESSURE CONTROL	LOW PRESSURE CONTROL
COMP	COMPRESSOR CONTACTOR	LPC	LPC
CON	CONDENSER	CON	CONDENSER
COU	CAPACITOR	PL1	PL1
COU	ELECTRIC COUPLING	PL2	PL2
COU	HIGH PRESSURE SWITCH	PL3	PL3
COU	INSULATED SWITCH DEVICE	PL4	PL4
COU	INSULATED SWITCH DEVICE	PL5	PL5
COU	INSULATED SWITCH DEVICE	PL6	PL6
COU	INSULATED SWITCH DEVICE	PL7	PL7
COU	INSULATED SWITCH DEVICE	PL8	PL8
COU	INSULATED SWITCH DEVICE	PL9	PL9
COU	INSULATED SWITCH DEVICE	PL10	PL10
COU	INSULATED SWITCH DEVICE	PL11	PL11
COU	INSULATED SWITCH DEVICE	PL12	PL12

COMPRESSOR	PART NO.
55/19 140	3582-555

USE THESE WIRE COLORS IF SO OPTAINS FIELD. **△** LABELLED WIRE COLOR IS NOT FOR 205V OPERATION. **△** RED WIRE FOR 50 Hz OPERATION ONLY.

WIRE NO	WIRE COLOR	WIRE NO	WIRE COLOR
1	RED	1	RED
2	BLACK	2	BLACK
3	GREEN	3	GREEN
4	BROWN	4	BROWN
5	ORANGE	5	ORANGE
6	YELLOW	6	YELLOW
7	PURPLE	7	PURPLE
8	PINK	8	PINK
9	GRAY	9	GRAY
10	WHITE	10	WHITE
11	SLATE	11	SLATE
12	BLACK	12	BLACK

FIELD SIDE

WIRE NO	WIRE COLOR	WIRE NO	WIRE COLOR
1	RED	1	RED
2	BLACK	2	BLACK
3	GREEN	3	GREEN
4	BROWN	4	BROWN
5	ORANGE	5	ORANGE
6	YELLOW	6	YELLOW
7	PURPLE	7	PURPLE
8	PINK	8	PINK
9	GRAY	9	GRAY
10	WHITE	10	WHITE
11	SLATE	11	SLATE
12	BLACK	12	BLACK

BACK SIDE

WIRE NO	WIRE COLOR	WIRE NO	WIRE COLOR
1	RED	1	RED
2	BLACK	2	BLACK
3	GREEN	3	GREEN
4	BROWN	4	BROWN
5	ORANGE	5	ORANGE
6	YELLOW	6	YELLOW
7	PURPLE	7	PURPLE
8	PINK	8	PINK
9	GRAY	9	GRAY
10	WHITE	10	WHITE
11	SLATE	11	SLATE
12	BLACK	12	BLACK

BARCO MFG. CO.
4064-118

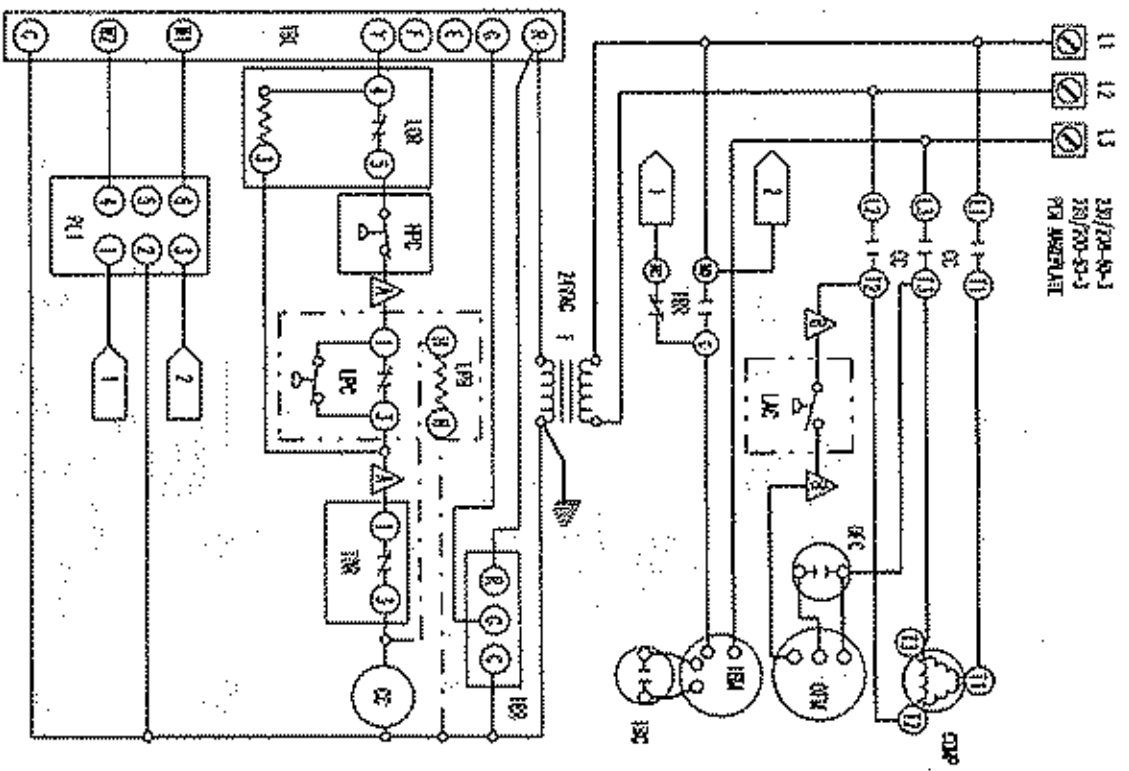
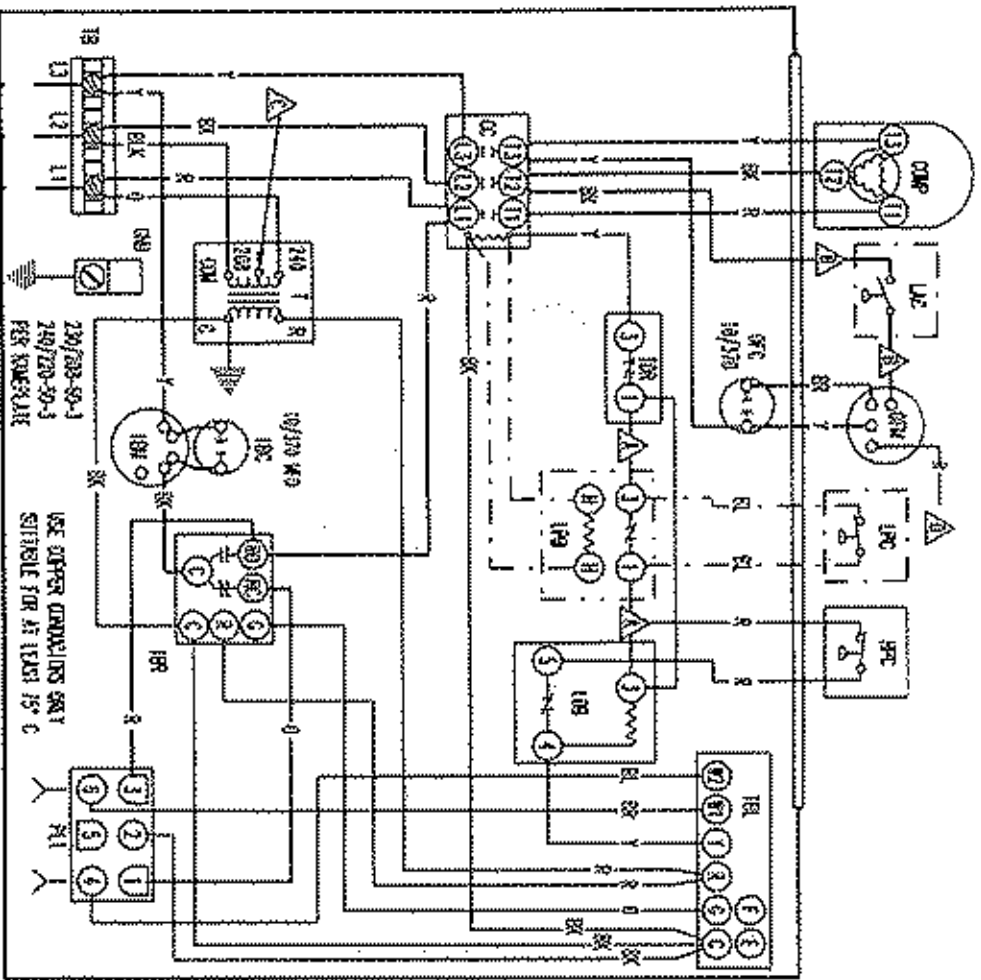

COMPONENT CODE	LOW PRESSURE SIGNAL	DESCRIPTION
13	13	10V PRESSURE SIGNAL
12	12	10V PRESSURE SIGNAL
11	11	10V PRESSURE SIGNAL
10	10	10V PRESSURE SIGNAL
9	9	10V PRESSURE SIGNAL
8	8	10V PRESSURE SIGNAL
7	7	10V PRESSURE SIGNAL
6	6	10V PRESSURE SIGNAL
5	5	10V PRESSURE SIGNAL
4	4	10V PRESSURE SIGNAL
3	3	10V PRESSURE SIGNAL
2	2	10V PRESSURE SIGNAL
1	1	10V PRESSURE SIGNAL

COMPONENT CODE	LOW PRESSURE SIGNAL	DESCRIPTION
13	13	10V PRESSURE SIGNAL
12	12	10V PRESSURE SIGNAL
11	11	10V PRESSURE SIGNAL
10	10	10V PRESSURE SIGNAL
9	9	10V PRESSURE SIGNAL
8	8	10V PRESSURE SIGNAL
7	7	10V PRESSURE SIGNAL
6	6	10V PRESSURE SIGNAL
5	5	10V PRESSURE SIGNAL
4	4	10V PRESSURE SIGNAL
3	3	10V PRESSURE SIGNAL
2	2	10V PRESSURE SIGNAL
1	1	10V PRESSURE SIGNAL

COMPONENT CODE	LOW PRESSURE SIGNAL	DESCRIPTION
13	13	10V PRESSURE SIGNAL
12	12	10V PRESSURE SIGNAL
11	11	10V PRESSURE SIGNAL
10	10	10V PRESSURE SIGNAL
9	9	10V PRESSURE SIGNAL
8	8	10V PRESSURE SIGNAL
7	7	10V PRESSURE SIGNAL
6	6	10V PRESSURE SIGNAL
5	5	10V PRESSURE SIGNAL
4	4	10V PRESSURE SIGNAL
3	3	10V PRESSURE SIGNAL
2	2	10V PRESSURE SIGNAL
1	1	10V PRESSURE SIGNAL

BAIRD INC. CO.
4064-213 A

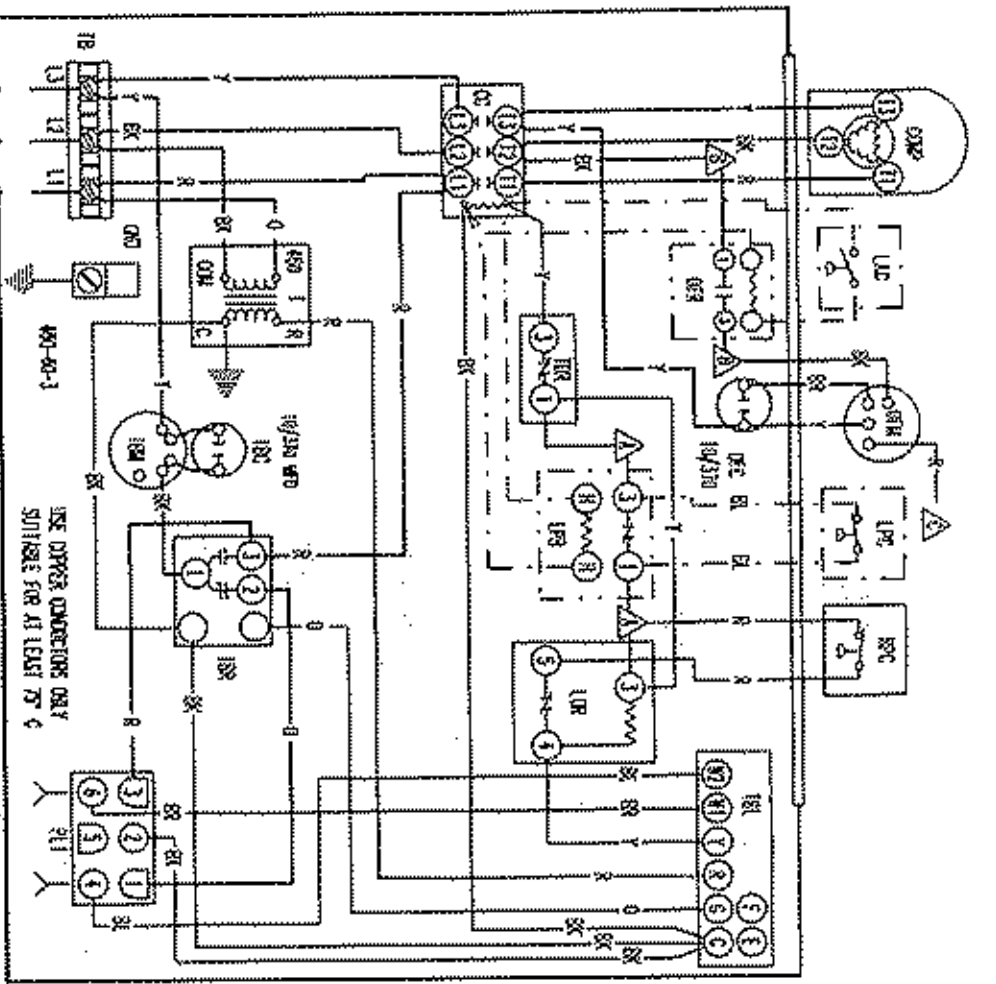

USE OTHER CONNECTIONS ONLY
SCHEDULE FOR AT LEAST 75°C

COMPONENTS

02	COMPRESSOR CONTACTOR	1PC	LOW PRESSURE CONTROL
03	COMPRESSOR	02C	RELAY FOR OPERATOR
04	DRY AIR OPERATOR	03C	RELAY FOR WIND
05	EQUIPMENT SHIELD	04C	RELAY FOR RELAY
06	HIGH PRESSURE CONTROL	R1	RELAY FOR
07	HIGH PRESSURE CONTACTOR	T	RELAY FOR
08	HIGH PRESSURE RELAY	08C	RELAY FOR
09	HIGH PRESSURE RELAY	09C	RELAY FOR
10	HIGH PRESSURE RELAY	10C	RELAY FOR
11	HIGH PRESSURE RELAY	11C	RELAY FOR
12	HIGH PRESSURE RELAY	12C	RELAY FOR
13	HIGH PRESSURE RELAY	13C	RELAY FOR
14	HIGH PRESSURE RELAY	14C	RELAY FOR
15	HIGH PRESSURE RELAY	15C	RELAY FOR
16	HIGH PRESSURE RELAY	16C	RELAY FOR
17	HIGH PRESSURE RELAY	17C	RELAY FOR
18	HIGH PRESSURE RELAY	18C	RELAY FOR
19	HIGH PRESSURE RELAY	19C	RELAY FOR

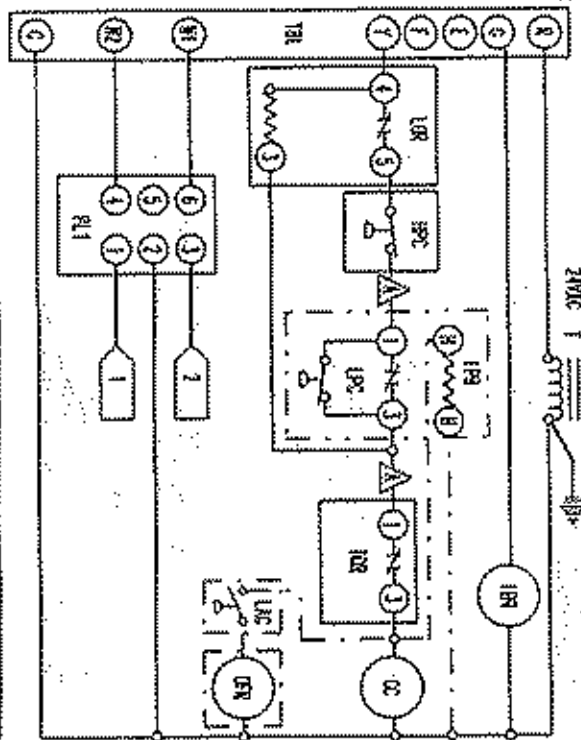
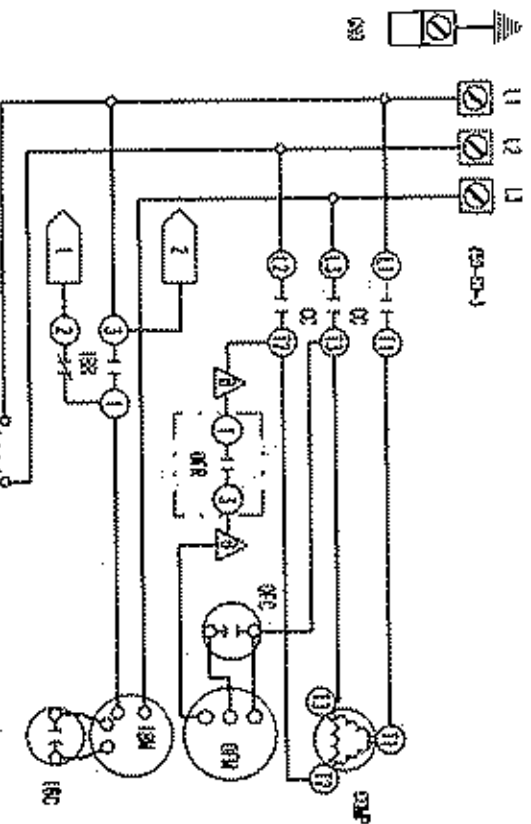

USED HERE ONLY IF NO OTHERS ARE

NOT FOR SO 22, SPECIFICATION ONLY

FACTORY SH. FIELD	OPTIONAL
HIGH VOLTAGE	---
LOW VOLTAGE	---
ACCESSORY	---

ORANGE	Y	YELLOW	Y	WHITE	W	BLACK	B
RED	R	GREEN	G	GRAY	GR	BLUE	BL
BROWN	BR	WHITE	WH	SLATE	SL	SLATE	SL
BLACK	BL	WHITE	WH	SLATE	SL	SLATE	SL

BAIRD MFG. CO.	4064-314 A
----------------	------------

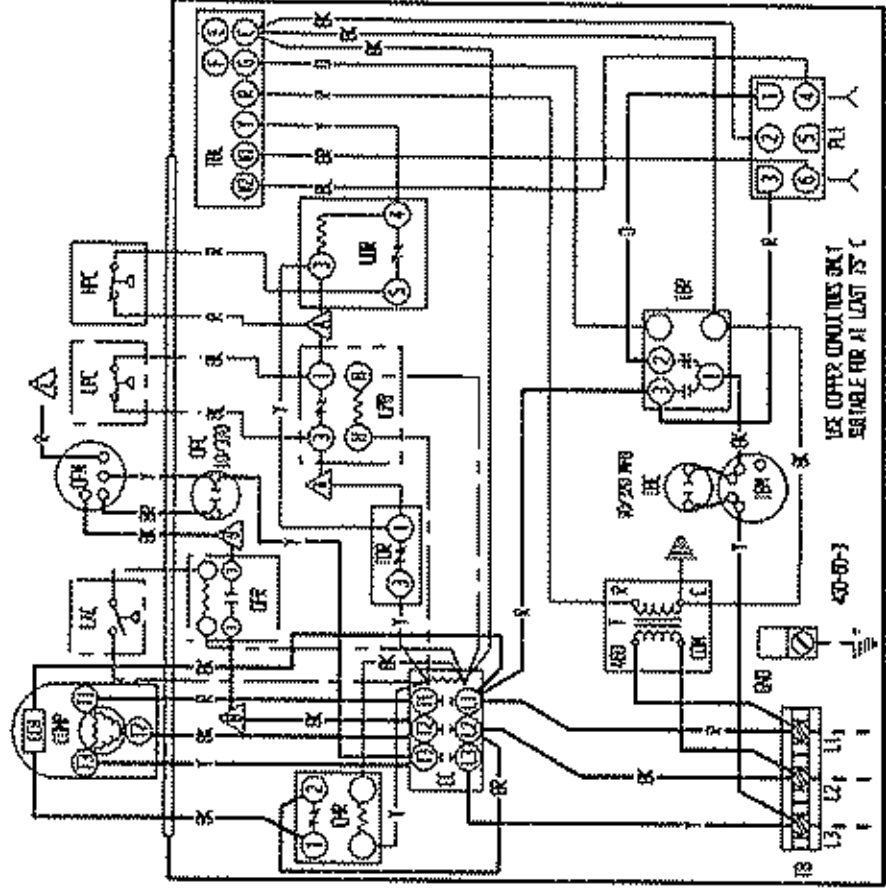
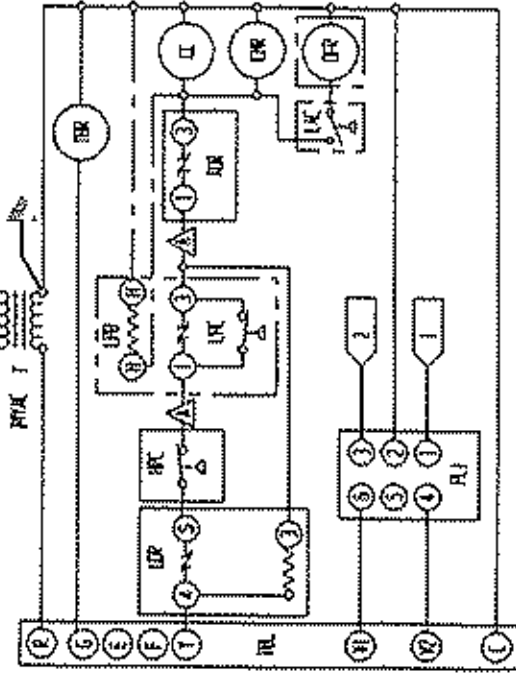
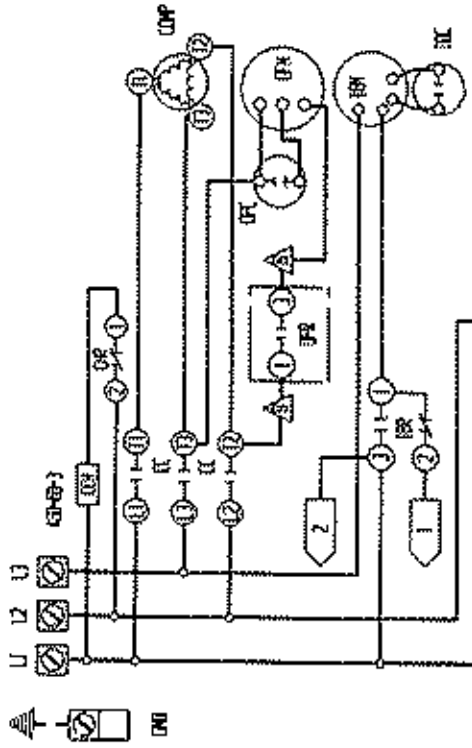

ORDERING CODE	
UR	UR1
UR2	UR3
UR4	UR5
UR6	UR7
UR8	UR9
UR10	UR11
UR12	UR13

Labeled Notes Contact P. in Options Used	
UR	UR1
UR2	UR3
UR4	UR5
UR6	UR7
UR8	UR9
UR10	UR11
UR12	UR13

BARCO MFG. CO.
4054-315

Y	Y	Y	Y	Y
UR	UR1	UR2	UR3	UR4
UR5	UR6	UR7	UR8	UR9
UR10	UR11	UR12	UR13	UR14

Y	Y	Y	Y	Y
UR	UR1	UR2	UR3	UR4
UR5	UR6	UR7	UR8	UR9
UR10	UR11	UR12	UR13	UR14

Y	Y	Y	Y	Y
UR	UR1	UR2	UR3	UR4
UR5	UR6	UR7	UR8	UR9
UR10	UR11	UR12	UR13	UR14