INSTALLATION INSTRUCTIONS

SINGLE PACKAGE HEAT PUMPS

MODELS
PH11422
PH1048
PH1060



Bard Manufacturing Company
Bryan, Ohio 43506

*Since 1914...Moving ahead, just
as planned.*

Manual : 2100-326
File: Volume II Tab 11
Date: 01-28-98

Contents

Getting Other Informations and Publications	1
General Instructions	4
Important	4
Shipping Damage	4
General	4
Field-Installed Heater Packages (Optional)	4
Installation	6
Location	6
Typical Installations	6
Condensate Drain Trap	9
Air Filters	9
Wiring – Main Power	10
Wiring – 24V Low Voltage Control Circuit	10
Thermostats	10
Thermostat Indicator Lamps	11
Emergency Heat Position	11
Transformer Taps	11
Compressor Cut-Off Thermostat and Outdoor Thermostat Wiring	11
Start Up and Operation	12
Three Phase Scroll Compressor Start Up Information	12
Sequence of Operation	12
Defrost Cycle	12
Start Up Notes	12
Service and Troubleshooting	14
Service Hints	14
Pressure Service Ports	14
Refrigerant Charge	14
Fan Blade Settings	14
Solid State Heat Pump Control Troubleshooting Procedure	14
Troubleshooting Guide	15
Checking Temperature Sensor Check Out	16
Temperature vs. Resistance of Temperature Sensor Chart	16
Suction and Discharge Tube Brazing	17
Pressure Tables	18
Wiring Diagrams	19

Figures

Figure 1 Prefabricated Rood Curb Specifications	5
Figure 2 Field Fabricated Curbing	5
Figure 3 Elevated Mounting Platforms	7
Figure 4 Airflow and Service Access Clearances	7
Figure 5 Roof Top Application	8
Figure 6 Slab Mounting at Ground Level	8
Figure 7 Condensate Drain Trap	9
Figure 8 Low Voltage Wiring	10
Figure 9 Compressor Cut-Off Wiring	11
Figure 10 Compressor Cut-Off and Outdoor Thermostat Wiring	11
Figure 11 Heat Pump Control Board	13
Figure 12 Fan Blade Setting Dimensions	14
Figure 13 Brazing Diagram	17

Tables

Table 1 Electric Heat Table	2
Table 2 Optional Field Installed Heater Packages	2
Table 3 Optional Field Installed Heater Table	3
Table 4 Maximum ESP of Operation	4
Table 5 Rated CFM and Rated ESP	6
Table 5A ESP in Inches H ₂ O	6
Table 6 Air Filter Area and Size	9
Table 7 Thermostat Wire Size	10
Table 8 Wall Thermostat and Subbase Combinations	10
Table 9 Volts, KW and Phase - Compressor Cut-Off Wiring	11
Table 10 Volts, KW and Phase - Compressor Cut-Off and Outdoor Thermostat Wiring	11
Table 11 Refrigerant Charge	14
Table 12 Pressure Table - Cooling	18
Table 13 Pressure Table - Heating	18

Getting Other Information and Publications

These publications can help you install the air conditioner or heat pump. You can usually find these at your local library or purchase them directly from the publisher. Be sure to consult current edition of each standard.

National Electrical Code ANSI/NFPA 70

Standard for the Installation ANSI/NFPA 90A
of Air Conditioning and
Ventilating Systems

Standard for Warm Air ANSI/NFPA 90B
Heating and Air
Conditioning Systems

Load Calculation for ACCA Manual J
Residential Winter and
Summer Air Conditioning

Duct Design for Residential ACCA Manual D
Winter and Summer Air Conditioning
and Equipment Selection

For more information, contact these publishers:

ACCA — Air Conditioning Contractors of America
1712 New Hampshire Ave. N.W.
Washington, DC 20009
Telephone: (202) 483-9370
Fax: (202) 234-4721

ANSI — American National Standards Institute
11 West Street, 13th Floor
New York, NY 10036
Telephone: (212) 642-4900
Fax: (212) 302-1286

**ASHRAE — American Society of Heating
Refrigerating, and
Air Conditioning Engineers, Incorporated**
1791 Tullie Circle, N.E.
Atlanta, GA 30329-2305
Telephone: (404) 636-8400
Fax: (404) 321-5478

NFPA — National Fire Protection Association
Batterymarch Park
P.O. Box 9101
Quincy, MA 02269-9901
Telephone: (800) 344-3555
Fax: (617) 984-7057

**TABLE 1
ELECTRICAL DATA**

Model	Rated Volts & Phases	Operating Voltage Range	Maximum Unit Amps	① Maximum External Fuses or Ckt. Brk.	Minimum Circuit Ampacity	② Field Power Wiring	② Ground Wire Size
				Ckt. A		Ckt. A	Ckt. A
PH11422	230/208-1	197 - 253	24.1	45	29	8	10
PH1048A1	230/208-1	197 - 253	26.9	50	36	8	10
PH1048-B	230/208-3	187-253	17.5	35	23	8	10
PH1048-C	460-3	414-506	8.6	20	13	12	12
PH1060	230/208-1	197 - 253	32.5	60	42	8	10
PH1060-B	230/208-3	187 - 253	22.8	45	28	8	10
PH1060-C	460-3	414 - 506	11.0	20	14	12	12

① Maximum time delay fuse or HACR type circuit breaker. HACR type not applicable to 460 volt.

② 75 degree C cooper wire size, basic unit only.

**TABLE 2
OPTIONAL FIELD INSTALLED HEATER PACKAGES
ONLY TO BE USED WITH THE HEAT PUMP MODELS INDICATED**

Heater Package Model No.	Volts and Phase	PH11422	PH1048	PH1048-B	PH1048-C	PH1060	PH1060-B	PH1060-C
EH5PB-A05	240/1	S	S	A	A	S	A	A
EH5PB-A10		S	S	A	A	S	A	A
EH5PB-A15		S	S	A	A	S	A	A
EH5PB-A20		S	S	A	A	S	A	A
EH5PB-B09	240/3		A	S	A	A	S	A
EH5PB-B15			A	S	A	A	S	A
EH5PB-B18				A	S	A	A	S
EH5PB-C09	480/3		A	A	S	A	A	S
EH5PB-C15			A	A	S	A	A	S
EH5PB-B18				A	A	S	A	A

S - Standard application - Heater volts and phase same as basic unit

A - Alternate application - Heater volts and phase different from basic unit

**TABLE 3
OPTIONAL FIELD-INSTALLED ELECTRIC HEATER TABLE**

Heater Pkg. Model No.	Unit Volts Phase	Htr. KW & Capacity @ 240V (or 480V if applicable)		Htr. KW & Capacity @ 208 Volts		@ 240V or 480V as applicable Htr. Amps	Heater Internal Fuses	Circuit B				
		KW	BTUH	KW	BTUH			No. Field Ckts.	Minimum Circuit Ampacity	① Maximum Overcurrent Protection	② Field Power Wiring	③ Ground Wire Size
EH5PB-A05	240/208-1	5	17,100	3.75	12,800	20.8		1	26	30	10	10
EH5PB-A10	240/208-1	10	34,100	7.50	26,000	41.7		1	53	60	6	10
EH5PB-A15	240/208-1	15	51,200	11.25	38,400	62.5	30/60	1	79	80	4	8
EH5PB-A20	240/208-1	20	68,200	15.00	51,200	83.2	60/60	1	104	110	2	6
EH5PB-B09	240/208-3	9	30,700	6.75	23,000	21.7		1	28	30	10	10
EH5PB-B15	240/208-3	15	51,200	11.25	38,400	36.2		1	46	50	8	10
EH5PB-B18	240/208-3	18	61,400	13.50	46,100	43.4		1	55	60	6	10
EH5PB-C09	460/3	9	30,700	6.75	23,000	10.8		1	15	15	14	14
EH5PB-C15	460/3	15	51,200	11.25	38,400	18.0		1	23	25	10	10
EH5PB-C18	460/3	18	61,400	13.50	46,100	21.7		1	28	30	10	10

- ① Time delay fuses or "HACR" type circuit breakers must be used for 60 and smaller sizes. Standard fuses or circuit breakers are suitable for sizes 70 and larger. 480V circuit breakers are not "HACR" type.
- ② Based on wire suitable for 75° C. Other wiring materials must be rated for marked "Minimum Circuit Ampacity" or greater.
- ③ Based upon Table 250-95 of N.E.C. 1993. See electrical data for basic heat pump for Circuit A wiring specification requirements.

IMPORTANT: While this electrical data is presented as a guide, it is important to electrically connect properly size fuses and conductor wires in accordance with the National Electrical Code and all existing local codes.

GENERAL INSTRUCTIONS

IMPORTANT

The equipment covered in this manual is to be installed by trained, experienced service and installation technicians. Any heat pump is more critical of proper operating charge and an adequate duct system than a straight air conditioning unit. All duct work, supply and return ducts, must be properly sized for the design air flow requirement of the equipment. ACCA is an excellent guide to proper sizing. All duct work or portions thereof not in the conditioned space should be properly insulated in order to both conserve energy and prevent condensation or moisture damage.

SHIPPING DAMAGE

Upon receipt of equipment, the carton should be checked for external signs of shipping damage. If damage is found, the receiving party must contact the last carrier immediately, preferably in writing, requesting inspection by the carrier's agent.

GENERAL

The refrigerant system is completely assembled and charged. All internal wiring is complete.

The unit is designed for use with or without duct work. Flanges are provided for attaching the supply and return ducts.

These instructions explain the recommended method to install the air cooled self-contained unit and the electrical wiring connections to the unit.

These instructions and any instructions packaged with any separate equipment required to make up the entire heat pump system should be carefully read before beginning the installation. Note particularly "Starting Procedure" and any tags and/or labels attached to the equipment.

While these instructions are intended as a general recommended guide, they do not supersede any national and/or local codes in any way. Authorities having jurisdiction should be consulted before the installation is made.

FIELD INSTALLED HEATER PACKAGES (OPTIONAL)

These packaged heat pumps are manufactured without supplementary electric heaters. Supplementary heaters EH5PB series (to fit PH11422, PH1048, and PH1060) are available for simple, fast, field installation.

A separate field power circuit is required for the supplementary heaters.

IMPORTANT: Refer to Table 4 and 5 when designing duct work for maximum available static pressure with heater installed.

Refer to the electrical data shown on pages 2 and 3 for proper application information on all available heater combinations and what units they can be used with. It also shows the applicable circuit ampacities, fuse size, and wire size for each heater combination.

Refer to the installation instructions packed with the heater for details on how to insert it into the basic unit.

TABLE 4
MAXIMUM ESP OF OPERATION

	PH11422	PH1048	PH1060
A00	.50	.50	.50
A05	.40	.50	.50
A10	.35	.50	.50
* A15	.35	.50	.50
* A20	.35	.50	.50
B00	---	.50	.50
B09	---	.50	.50
* B15	---	.50	.50
* B18	---	.50	.50
C00	---	.50	.50
C09	---	.50	.50
* C15	---	.50	.50
* C18	---	.50	.50

* NOTE: Maximum electric heat with heat pump is 10 KW. On higher KWs, the remaining KW is used during compressor cutout or emergency heat only.

**FIGURE 1
 PREFABRICATED ROOF CURB SPECIFICATIONS
 HEAVY GAUGE GALVANIZED WITH WOOD NAILING STRIP, WELDED/LEAKPROOF
 ONE PIECE CONSTRUCTION – READY TO INSTALL**

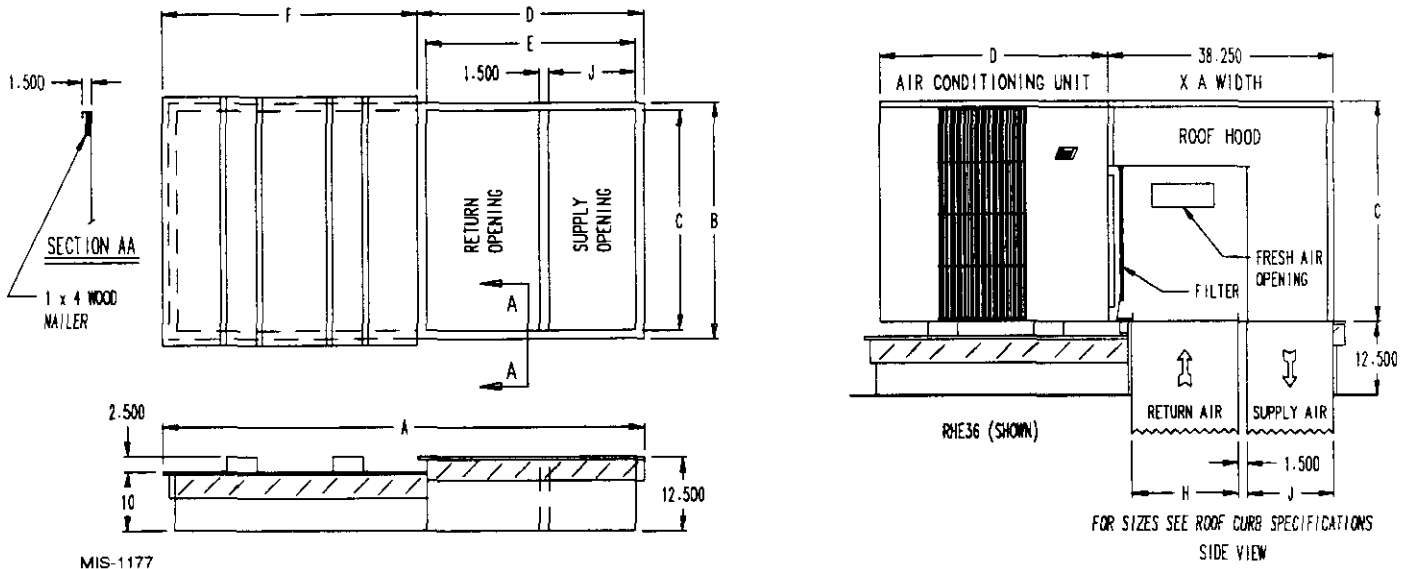

MIS-1177

CURB AND ROOF DETAILS

Roof Curb	A	B	C*	D	E	F	J*	H*	Roof Hood Model	Air Conditioning Units
9042-004	82-3/8	44-1/8	41-1/8	38-3/8	35-3/8	44	14-3/4	19-1/8	RHE60	PH11422, PH1048, PH1060

*Duct Sizing Information

Return Air Dimension "C" is length
 Return Air Dimension "H" is width

Supply Air Dimension "C" is length
 Supply Air Dimension "J" is width

**FIGURE 2
 FIELD FABRICATED CURBING**

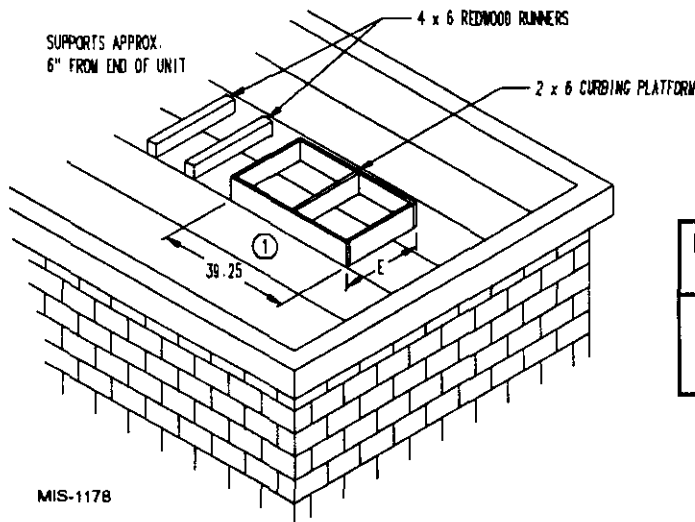

MIS-1178

Roof Hood Model	Unit Model	E
RHE60	PH11422 PH1048 PH1060	44-7/8

① A SEPARATE METAL FLASHING SHOULD BE INSTALLED AROUND WOOD CURBING. CAULK & SEAL ALL JOINTS & WEATHERPROOF.

INSTALLATION

LOCATION

GENERAL

The unit must be located outside, or in a well ventilated area. It must not be in the space being heated or cooled. A sound absorbing material should be considered if the unit is to be installed in such a position or location that might cause transmission of sound or vibration to the living area or adjacent buildings.

SLAB MOUNTING

In areas where winter temperatures *DO NOT* go below 32° F for periods over twelve hours, the unit may be slab mounted at grade level. When installing unit at grade level, install on a concrete slab at least four inches above finished grade level. Slab should have a slope tolerance away from the building structure of at least 1/4 inch per foot, while being level from side to side. This will prevent ice buildup under the unit during defrost cycles. Place slab in a location where runoff water from higher ground will not collect around unit. See Figure 3.

A minimum of 18 inches should be provided between the coil inlet and any building surfaces. Provide at least four feet between coil outlet and any building wall, fences or other vertical structures. Provide a minimum of three feet clearance on the service access side of the unit. See Figure 4

ROOF MOUNTING

When a unit is installed in areas where low ambient temperatures or strong winter winds exist, it should be placed so prevailing winter winds are not in direct line with the heat pump coil. If this is not possible, a wind barrier should be constructed. Place barrier 24 inches from the coil inlet side of the unit and in the direction of prevailing winds. Size barrier at least the same height and width as the unit. This may be necessary on ground level installations, also. See Figure 5.

WINTER INSTALLATION BELOW 32°F

In areas where winter conditions go below 32°F for extended periods, the unit must be elevated above the mounting surface to prevent snowfall or defrost ice accumulation from interfering with the operation of the unit. A minimum of twelve inch elevation is recommended, while greater elevation may be required for areas of high snow accumulation. Poured concrete, steel framework, brick, cement block, etc., can be utilized to construct a suitable raised mounting platform. See Figure 6.

DUCT WORK

Refer to Tables 4, 5 and 5A when designing duct work for maximum static pressure available with the specific model and heater package being installed. Unit duct work is suitable for 0" clearance to combustible materials.

**TABLE 5
RATED CFM AND
EXTERNAL STATIC PRESSURE (ESP)
WET COIL (COOLING)**

Model	Rated CFM	Rated ESP	Recommended Air Flow Range
PH11422	1400	.20	1260 - 1540 CFM
PH1048	1550	.40	1400 - 1700 CFM
PH1060	1700	.20	1530 - 1870 CFM

TABLE 5A

ESP Inches H ₂ O	P1142A3 PH11422 Dry / Wet	P1148A1 PH1048 Dry / Wet	P1060A1 PH1060 Dry / Wet
0	1650 / 1625	1950 / 1920	1850 / 1850
.1	1550 / 1525	1860 / 1830	1800 / 1780
.2	1435 / 1400	1780 / 1750	1725 / 1700
.3	1340 / 1310	1680 / 1660	1660 / 1625
.4	1230 / 1210	1580 / 1550	1580 / 1540
.5	1120 / 1100	1500 / 1480	1500 / 1475

TYPICAL INSTALLATIONS

- 1. ROOF MOUNTED** – The unit is mounted on a sturdy base on the roof of the building. Return air to the unit is brought through a single return grille (grilles with built-in filters are best since they enable easy access for filter changing). Return air ducts are attached to the lower section of the front panel. Supply air is brought from the unit to attic duct work or to a furred down hall. Supply air duct is attached to the top of the front panel.

CAUTION: All outdoor duct work must be thoroughly insulated and weatherproofed. All attic duct work must be thoroughly insulated. Two inch thick insulation with suitable vapor barrier is recommended for both outdoor and attic runs.

In roof top installation, as in all installations, the heat pump must be level from side to side. However, the unit should have a pitch along the length to assure complete external drainage of precipitation and of defrost condensate.

- 2. CRAWL SPACE** – Duct work installed in crawl space must be well insulated and provided with a vapor barrier. In addition, the crawl space must be thoroughly ventilated and provided with a good vapor barrier as a ground cover. It is most desirable to install the unit outdoors rather than inside the crawl space, so that it will be readily accessible for service. In addition, it is necessary to dispose of the condensate from the outdoor coil on the heating cycle, and this is virtually impossible with the unit installed inside the crawl space.

**FIGURE 3
ELEVATED MOUNTING PLATFORMS**

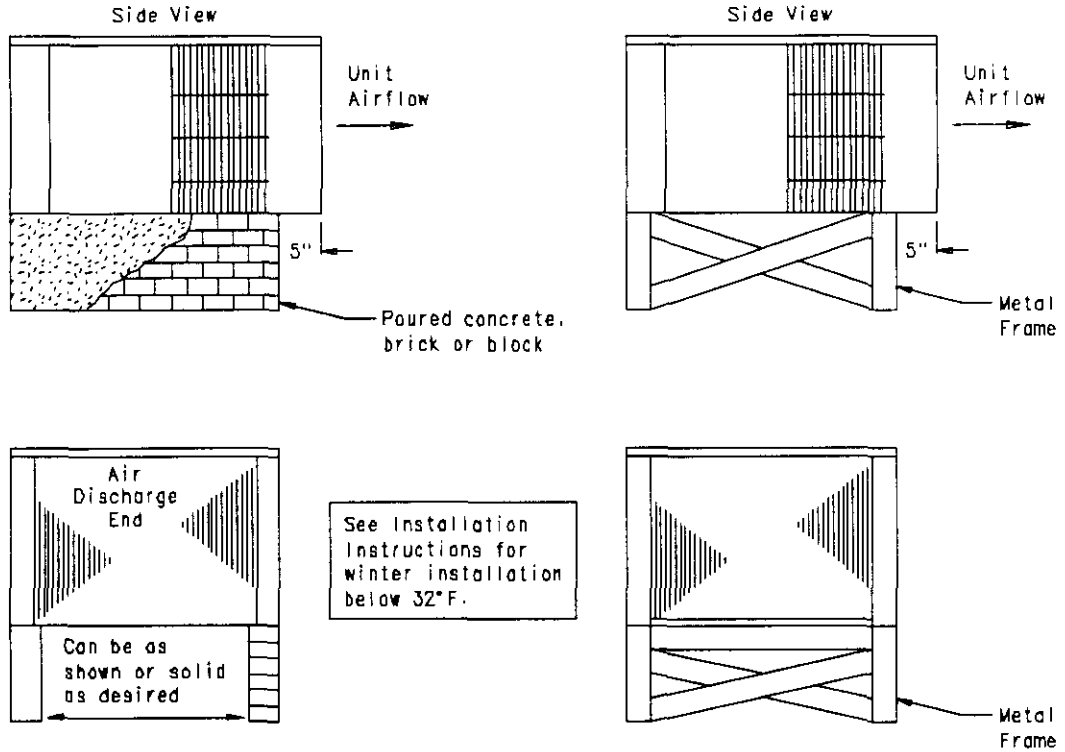

MIS-1183

**FIGURE 4
AIRFLOW and SERVICE ACCESS CLEARANCES**

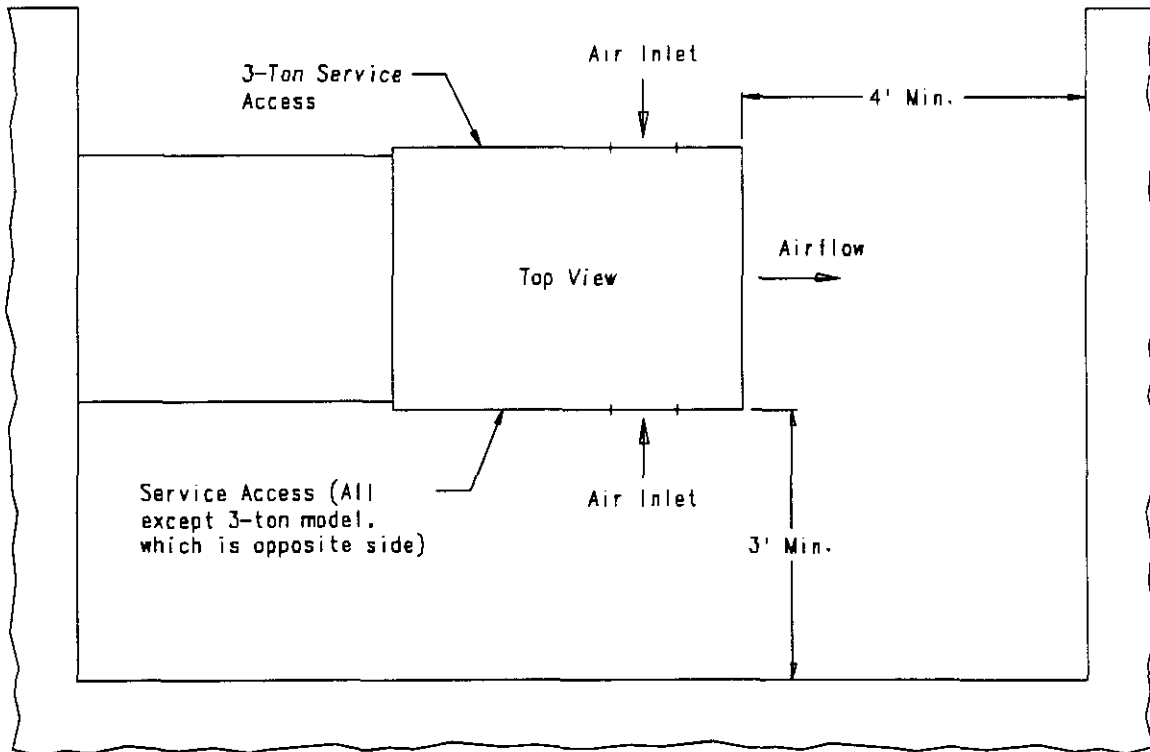

MIS-1185

FIGURE 5
ROOF TOP APPLICATION
 (May also be required for ground level installations.)

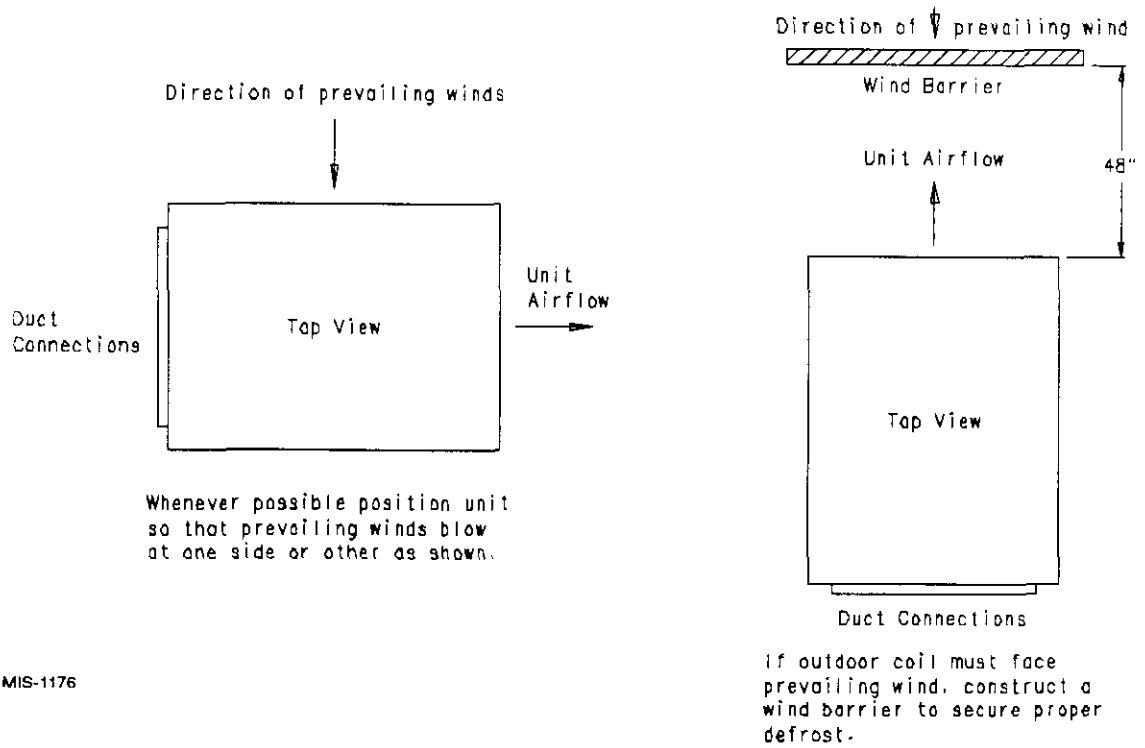
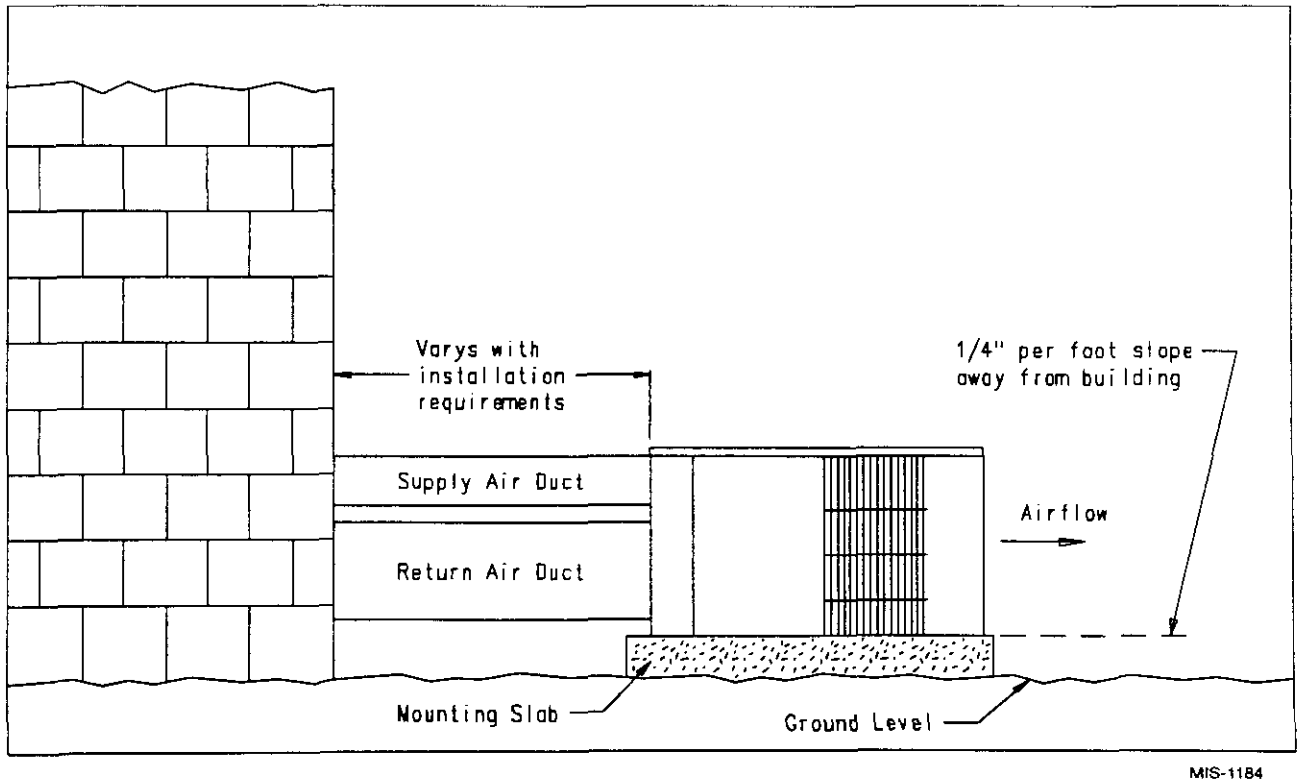

FIGURE 6
SLAB MOUNTING AT GROUND LEVEL
 (Above 32° F Outside Temperature)



3. **SLAB MOUNTED AT GROUND LEVEL** – This type installation is ideal for homes with a slab floor construction where a roof mounted unit is not desired. The supply and return duct work can be run through a furred closet space.
4. **THROUGH THE WALL** – This type installation requires a suitable framework to be fabricated capable of withstanding the unit weight. Normally the unit will be insulated so as to minimize supply and return duct work.
5. **OTHER INSTALLATIONS** – Many other installations are possible with the packaged heat pump. No matter what the installation, always consider the following facts:
 - A. Insure that the discharge air is not obstructed in any way so as to cause operation difficulties.
 - B. The indoor coil drain pan is equipped with a coupling that must be piped through a condensate drain trap to a suitable drain.
 - C. Always mount the unit in such a position that it may be easily reached for servicing and maintenance.
 - D. Insure that the unit is clear so that proper air flow over the outdoor coil will be maintained.

If this unit is operated in cooling below a 65° outdoor ambient temperature, the installation of low ambient controls (CMA-6) to unit is required.

CONDENSATE DRAIN TRAP

It is very important to provide a trap in the condensate drain line to allow a positive liquid seal in the line and assure correct drainage from the coil condensate pan.

Install condensate drain trap shown in Figure 7. Use drain connection size or larger. Do not operate unit without trap. Unit must be level or slightly inclined toward drain. With a

trap installed on a unit located in an unconditioned area, water in the trap may freeze. It is recommended that the trap material be of a type that will allow for expansion of water when it freezes.

AIR FILTERS

Air filters for the return air side of the system are not provided as part of the various types of applications for these models, and must be field supplied and installed as part of the final installation.

Prior thought should be given to return air location and placement of the air filter(s). The air filter(s) must be of adequate size and readily accessible to the operator of the equipment. Filters must be adequate in size and properly maintained for proper operation. If this is not done, excessive energy use, poor performance, and multiple service problems will result. *It is impossible to oversize air filters.* Generous sizing will result in cleaner air and coils as well as lower operating costs and extend the time between required changes. Table 6 shows minimum filter areas and recommended filter sizes. Actual filter sizes can vary with the installation due to single or multiple returns utilizing a filter/grille arrangement or being placed immediately ahead of the indoor coil face in the return air duct.

TABLE 6

Model	Minimum Filter Areas	Recommended Size
PH11422 PH1048 PH1060	608 square inches (4.62 square feet)	(2) 16 x 20 x 1

NOTE: If roof hood accessory is to be used, information on air filters may be found under that heading in this manual. Air filters are supplied as part of that package.

FIGURE 7
CONDENSATE DRAIN TRAP

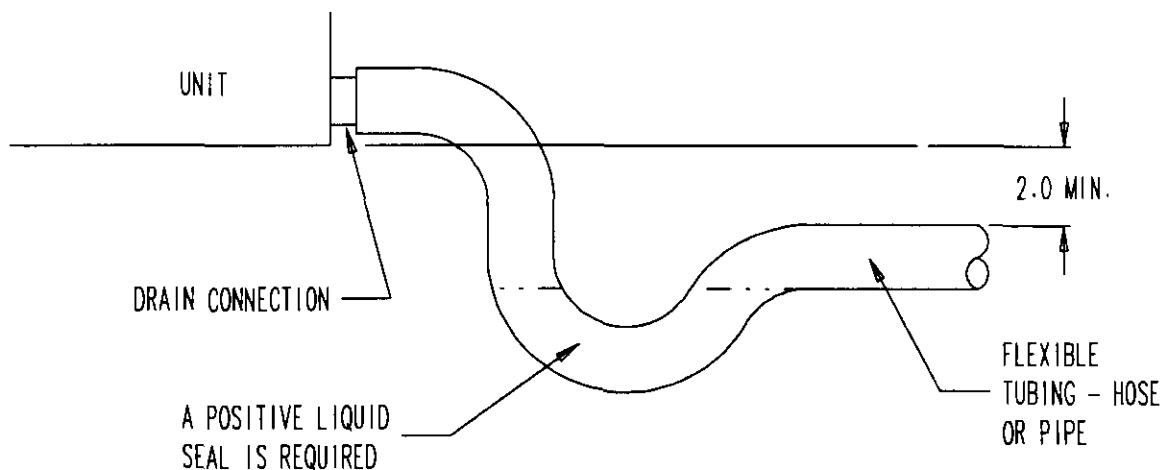

MIS-136

WIRING – MAIN POWER

Refer to the unit rating plate for wire sizing information and maximum fuse size. Each outdoor unit is marked with a "Minimum Circuit Ampacity". This means that the field wiring used must be sized to carry that amount of current. If field installed heaters are added to the basic unit, a second separate power supply circuit will be required. The heater rating plate located adjacent to the basic unit rating plate will show the appropriate circuit ampacity fuse size, etc. (Also see "Electrical Data" on pages 2 and 3.) *All models are suitable for connection with copper wire only.* These instructions **must** be adhered to. Refer to the National Electrical Code for complete current carrying capacity data on the various insulation grades of wiring material.

The electrical specifications on page 2 and 3 lists fuse and wire sizes (75°F copper) for all models including the most commonly used heater sizes.

The unit rating plate lists a "Maximum Time Delay Fuse" or "HACR" type circuit breaker that is to be used with the equipment. The correct size must be used for proper circuit protection and also to assure that there will be no nuisance tripping due to the momentary high starting current of the compressor.

WIRING – 24V LOW VOLTAGE CONTROL CIRCUIT

Ten (10) wires should be run from thermostat subbase to the 24V terminal board in the unit. A nine conductor, 18 gauge copper, color-coded thermostat cable is recommended. The connection points are shown in Figure 8.

FIGURE 8 – LOW VOLTAGE WIRING

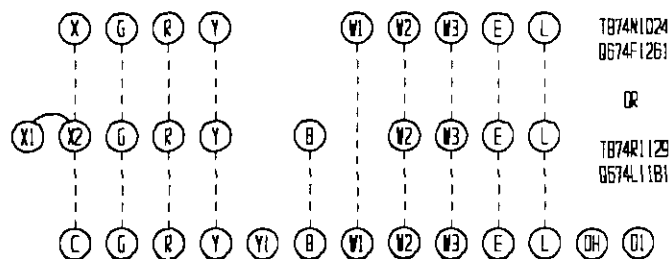

MIS-1186

TABLE 7 – THERMOSTAT WIRE SIZE

Transformer VA	FLA	Wire Gauge	Maximum In Feet
55	2.3	20	45
		18	60
		16	100
		14	160
		12	250

THERMOSTATS

See specific wiring information for the different models, heater KWs, and voltages on pages 19 through 22.

TABLE 8
WALL THERMOSTAT and SUBBASE COMBINATIONS

Group	Thermostat	Subbase	Predominant Feature
A	8403-017 (T874R1129)	8404-009 (Q674L1181)	Heat or Cool No Auto ①
B	8403-018 (T874N1024)	8404-010 (Q674F1261)	Automatic Heat - Cool Changeover Position ②

- ① No automatic changeover position – must be manually placed in heat or cool. Reversing valve remains energized at all times system switch is in heat position (except during defrost cycle). No pressure equalization noise when thermostat is satisfied on either heating or cooling.
- ② Allows thermostat to control both heating and cooling operation when set in "AUTO" position. Reversing valve de-energizes at end of each "ON" heating cycle.

IMPORTANT NOTE: Only the thermostat and subbase combinations as shown above will work with this equipment. The thermostat and subbase **MUST** be matched, and correct operation can be assured only by proper selection and application of these parts. The above combinations incorporate the following features: Man-Auto fan switch, Off-Heat-Cool-Em. Heat Switch, and two (2) indicator lamps - - one for emergency heat and one for compressor malfunction.

THERMOSTAT INDICATOR LAMPS

The red lamp marked "EM. HT." comes on and stays on whenever the system switch is placed in Em. Ht. position. The green lamp marked "Check" will come on if there is any problem that prevents the compressor from running when it is supposed to be.

EMERGENCY HEAT POSITION

The operator of the equipment must manually place the system switch in this position. This is done when there is a known problem with the outdoor section, or when the green "Check" lamp comes on indicating a problem.

TRANSFORMER TAPS

230/208V, 1 phase and 3 phase equipment employ dual primary voltage transformers. All equipment leaves the factory wired on 240V tap. For 208V operation, reconnect from 240V to 208V tap. The acceptable operating voltage range for the 240 and 208V taps are:

TAP	RANGE
240	253 - 216
208	220 - 187

NOTE: The voltage should be measured at the field power connection point in the unit and while the unit is operating at full load (maximum amperage operating condition).

COMPRESSOR CUT-OFF THERMOSTAT and OUTDOOR THERMOSTAT WIRING

Heat pump compressor operation at outdoor temperatures below 0°F are neither desirable nor advantageous in terms of efficiency. Since most equipment at time of manufacture is not designated for any specific destination of the county and most of the equipment is installed in areas not approaching the lower outdoor temperature range, the compressor cut-offs are not factory installed.

Outdoor thermostats are available to hold off various banks of electric heat until needed as determined by outdoor temperature. The set point of either type of thermostat is variable with geographic region and sizing of the heating equipment to the structure. Utilization of the Heating Application Data and the heat loss calculation of the building are useful in determining the correct set points.

COMPRESSOR CUT-OFF WIRING

FIGURE 9
UNIT 24V TERMINAL BOARD

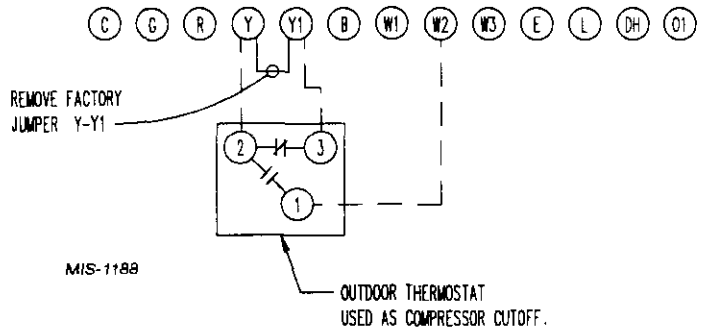

TABLE 9

Model	KW	Volts	Phase
PH11422	0, 5, 10	230	1
PH1048	0, 5, 10	230	1
PH1048-B, -C	0, 9	230, 460	3
PH1060	0, 5, 10	230	1
PH1060-B, -C	0, 9	230, 460	3

COMPRESSOR CUT-OFF and OUTDOOR THERMOSTAT WIRING

FIGURE 10
UNIT 24V TERMINAL BOARD

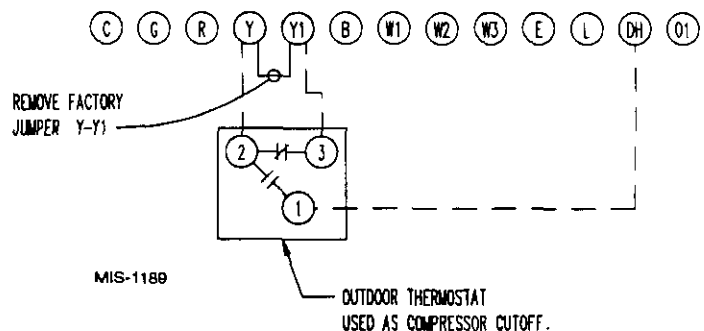

TABLE 10

Model	KW	Volts	Phase
PH11422	15, 20	230	1
PH1048	15, 20	230	1
PH1048-B, -C	15, 18	230, 460	3
PH1060	15, 20	230	1
PH1060-B, -C	15, 18	230, 460	3

START UP AND OPERATION

THREE PHASE SCROLL COMPRESSOR START UP INFORMATION

Scroll compressors, like several other types of compressors, will only compress in one rotational direction. Direction of rotation is not an issue with single phase compressors since they will always start and run in the proper direction.

However, three phase compressors will rotate in either direction depending upon phasing of the power. Since there is a 50-50 chance of connecting power in such a way as to cause rotation in the reverse direction, verification of proper rotation must be made. Verification of proper rotation direction is made by observing that suction pressure drops and discharge pressure rises when the compressor is energized. Reverse rotation also results in an elevated sound level over that with correct rotation, as well as, substantially reduced current draw compared to tabulated values.

Verification of proper rotation must be made at the time the equipment is put into service. If improper rotation is corrected at this time there will be no negative impact on the durability of the compressor. However, reverse operation for over one hour may have a negative impact on the bearing due to oil pump out.

NOTE: If compressor is allowed to run in reverse rotation for several minutes the compressor's internal protector will trip.

All three phase ZR*3 compressors are wired identically internally. As a result, once the correct phasing is determined for a specific system or installation, connecting properly phased power leads to the same Fusite terminals should maintain proper rotation direction.

The direction of rotation of the motor may be changed by reversing any two line connections to the unit.

SEQUENCE OF OPERATION

COOLING – Circuit R-Y makes at thermostat pulling in compressor contactor starting the compressor and outdoor motor. The G (indoor motor) circuit is automatically completed on any call for cooling operation, or can be energized by manual fan switch on subbase for constant air circulation.

HEATING – A 24V solenoid coil on reversing valve controls heating cycle operation. Two thermostat options, one allowing "AUTO" changeover from cycle to cycle and the other constantly energizing solenoid coil during heating season and thus eliminating pressure equalization noise except during defrost, are to be used. On "AUTO" option, a circuit is completed from R-W1 and R-Y on each heating "On" cycle energizing reversing valve solenoid and pulling in compressor contactor starting compressor and outdoor motor. R-G also make starting indoor blower motor. Heat pump heating cycle now in operation. The second energizes

the reversing valve solenoid constantly whenever the system switch on subbase is placed in "Heat" position, the "B" terminal being constantly energized from R. A thermostat demand for heat completes R-Y circuit, pulling in compressor contactor starting compressor and outdoor motor. R-G also make starting indoor blower motor.

DEFROST CYCLE

The defrost cycle is controlled by temperature and time on the solid state heat pump control.

When the outdoor temperature is in the lower 40°F temperature range or colder, the outdoor coil temperature is 32°F or below. This temperature is sensed by the coil sensor mounted near the bottom of the outdoor coil. Once the coil temperature reaches 32°F or below, the coil sensor sends a signal to the control logic of the heat pump control and defrost timer will start.

After 60 (90 or 30) minutes at 32°F or below, the heat pump control will place the system in the defrost mode.

During the defrost mode, the refrigerant cycle switches back to the cooling cycle, the outdoor motor stops, electric heaters are energized, and hot gas passing through the outdoor coil melts any accumulated frost. When the temperature rises to approximately 57°F, the coil sensor will send a signal to the heat pump control which will return the system to heating operations automatically.

If some abnormal or temporary condition such as a high wind causes the heat pump to have a prolonged defrost cycle, the heat pump control will restore the system to heating operation automatically after 10 minutes.

There are three settings on the heat pump control -- 30 minutes, 60 minutes, and 90 minutes. Most models are shipped wired on the 60 minutes setting for greatest operating economy. If special circumstances require a change to another time, remove wire connected to terminal 60 and reconnect to desired terminal. (See Figure 11.)

There is a cycle speed up jumper on the control. This can be used to reduce the time between defrost cycle operation without waiting for time to elapse.

There is an initial defrost (sen jmp) jumper on the control that can be used at any outdoor ambient during the heating cycle to simulate a 0° coil temperature. This can be used to check defrost operation of the unit without waiting for the outdoor ambient to fall into the defrost region.

START UP NOTES

For improved start up performance, wash the indoor coil with dishwasher detergent

FIGURE 11
HEAT PUMP CONTROL BOARD

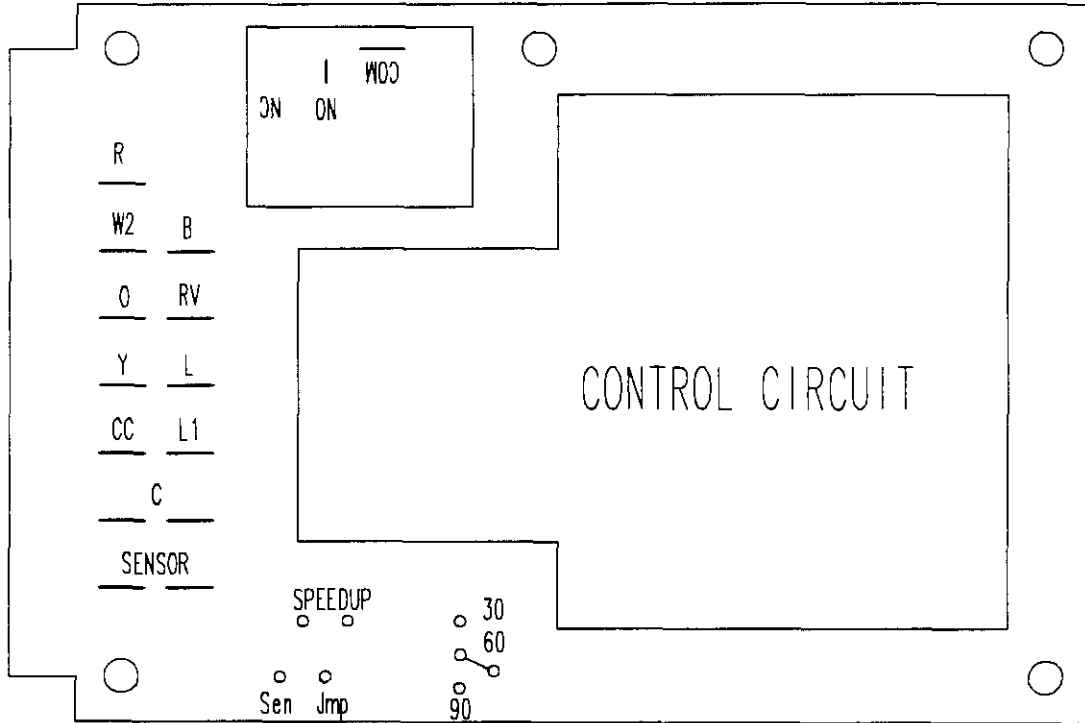

MIS-1191

SERVICE AND TROUBLESHOOTING

SERVICE HINTS

1. Caution homeowner to maintain clean air filters at all times. Also, not to needlessly close off supply and return air registers. This reduces air flow through the system which shortens equipment service life as well as increasing operating costs.
2. Switching to heating cycle at 75°F or higher outside temperature may cause a nuisance trip of the manual reset high pressure switch.
3. The heat pump wall thermostats perform multiple functions. Be sure that all function switches are correctly set for the desired operating mode before trying to diagnose any reported service problems.
4. Check all power fuses or circuit breakers to be sure that they are the correct rating.
5. Periodic cleaning of the outdoor coil to permit full and unrestricted airflow circulation is essential.

PRESSURE SERVICE PORTS

High and low pressure service ports are installed on all units so that the system operating pressures can be observed. Pressure tables can be found in Tables 12 and 13 in this manual covering all models on both cooling and heating cycles. It is imperative to match the correct pressure table to the unit by model number.

REFRIGERANT CHARGE

The correct system R-22 charge is shown on the unit rating plate. Optimum unit performance will occur with a refrigerant charge resulting in a suction line temperature (6" from compressor) as shown in Table 11.

TABLE 11

Model	Rated Airflow	95 Degree F OD Temperature	82 Degree F OD Temperature
PH11422	1400	54 - 56	57 - 59
PH1048	1550	54 - 56	59 - 61
PH0160	1700	52 - 54	57 - 59

The above suction line temperatures are based upon 80°F dry bulb/67°F wet bulb (50% RH) temperature and rated airflow across the evaporator during cooling cycle.

FAN BLADE SETTINGS

Shown in Figure 12 are the correct fan blade setting dimensions for proper air delivery across the outdoor coil.

Any service work requiring removal or adjustment in the fan and/or motor area will require that the dimensions in Figure 12 be checked and blade adjusted in or out on the motor shaft accordingly.

FIGURE 12
FAN BLADE SETTING DIMENSIONS

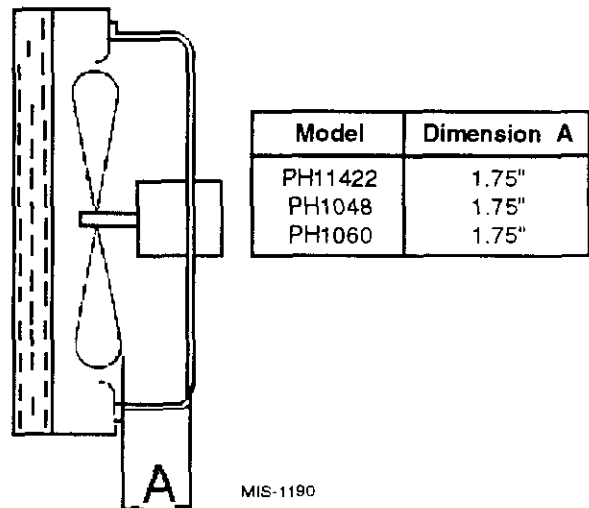

SOLID STATE HEAT PUMP CONTROL TROUBLESHOOTING PROCEDURE

1. Turn on AC power supply to indoor and outdoor units.
2. Turn thermostat blower switch to fan on. The indoor blower should start. (If it doesn't, troubleshoot indoor unit and correct problem.)
3. Turn thermostat blower switch to Auto position. Indoor blower should stop.
4. Set system switch to heat or cool. Adjust thermostat to call for heat or cool. The indoor blower, compressor, and outdoor fan should start.

NOTE: If there is no power to 24 volt transformer, the compressor and outdoor fan motor will not start for 5 minutes. This is because of the compressor short cycle protection.

TROUBLE SHOOTING GUIDE

Symptom	Possible Causes	What to Check	How to Check or Repair
Compressor contactor does not energize (heating or cooling)	Contil circuit wiring	Check for R connection at unit and 24 volt between R-C.	Run R connection to outdoor unit to power heat pump control.
	Compressor lock out	1. Check for 24V between L1-C on heat pump control 2. Check across high pressure switch.	1. If no voltage between L1-C, turn thermostat off and on again to reset high pressure switch. 2. If high pressure switch is open and will not reset, replace high pressure switch.
	Compressor short cycle protection	Check for 24V between CC-C and Y-C on heat pump control.	If no voltage between CC-C, jumper speed up terminal, and within 10 seconds power should appear between CC-C. Remove speed up jumper after 10 seconds.
	Heat pump control defective	Check all other possible causes. Manual 2100-065.	Replace heat pump control.
	Contactor defective	Check for open or shorted coil winding.	Replace contactor.
Fan outdoor motor does not run (cooling or heating except during defrost)	Motor defective	Check for open or shorted motor winding.	Replace motor.
	Motor capacitor defective	Check capacitor rating. Check for open or shorted capacitor.	Replace capacitor.
	Heat pump control defective	Check across fan relay on heat pump control. (Com-NC)	Replace heat pump control.
Reversing valve does not energize (heating only)	Reversing volve solenoid coil defective	Check for open or shorted coil.	Replace solenoid coil.
	Heat pump control defective	Check for 24V between RV-C and B-C.	1. Check control circuit wiring. 2. Replace heat pump control
Unit will not go into defrost (heating only)	Temperature sensor or heat pump control defective	Disconnect temperature sensor from board and jumper across speed up terminals and sen jump terminals. This should cause the unit to go through a defrost cycle within one minute.	1. If unit goes through defrost cycle, replace temperature sensor. 2. If unit does not go through defrost cycle, replace heat pump control.
Unit will not come out of defrost (heating only)	Temperature sensor or heat pump control defective.	Jumper across speed up terminals. This should cause the unit to come out of defrost within one minute.	1. If unit comes out of defrost cycle, replace temperature sensor. 2. If unit does not come out of defrost cycle, replace heat pump control.

CHECKING TEMPERATURE SENSOR CHECK OUT

1. Disconnect temperature sensor from board and from outdoor coil.
2. Use an ohmmeter and measure the resistance of the sensor. Also use ohmmeter to check for short or open.
3. Check resistance reading to chart of resistance; use sensor ambient temperature. (Tolerance of part is $\pm 10\%$.)
4. If sensor resistance reads very low, then sensor is shorted and will not allow proper operation of the heat pump control.
5. If sensor is out of tolerance, shorted, open, or reads very low ohms then it should be replaced.

TEMPERATURE F vs RESISTANCE R OF TEMPERATURE SENSOR

F	R	F	R	F	R	F	R
-25.0	196871	15.0	53640	55.0	17434	95.0	6531
-24.0	190099	16.0	52051	56.0	16984	96.0	6383
-23.0	183585	17.0	50514	57.0	16547	97.0	6239
-22.0	177318	18.0	49028	58.0	16122	98.0	6098
-21.0	171289	19.0	47590	59.0	15710	99.0	5961
-20.0	165487	20.0	46200	60.0	15310	100.0	5827
-19.0	159904	21.0	44855	61.0	14921	101.0	5697
-18.0	154529	22.0	43554	62.0	14544	102.0	5570
-17.0	149355	23.0	42295	63.0	14177	103.0	5446
-16.0	144374	24.0	41077	64.0	13820	104.0	5326
-15.0	139576	25.0	39898	65.0	13474	105.0	5208
-14.0	134956	26.0	38757	66.0	13137	105.0	5094
-13.0	130506	27.0	37652	67.0	12810	107.0	4982
-12.0	126219	28.0	36583	68.0	12492	108.0	4873
-11.0	122089	29.0	35548	69.0	12183	109.0	4767
-10.0	118108	30.0	34545	70.0	11883	110.0	4663
-9.0	114272	31.0	33574	71.0	11591	111.0	4562
-8.0	110575	32.0	32634	72.0	11307	112.0	4464
-7.0	107010	33.0	31723	73.0	11031	113.0	4367
-6.0	103574	34.0	30840	74.0	10762	114.0	4274
-5.0	100260	35.0	29986	75.0	10501	115.0	4182
-4.0	97064	36.0	29157	76.0	10247	116.0	4093
-3.0	93981	37.0	28355	77.0	10000	117.0	4006
-2.0	91008	38.0	27577	78.0	9760	118.0	3921
-1.0	88139	39.0	26823	79.0	9526	119.0	3838
0.0	85371	40.0	26092	80.0	9299	120.0	3757
1.0	82699	41.0	25383	81.0	9077	121.0	3678
2.0	80121	42.0	24696	82.0	8862	122.0	3601
3.0	77632	43.0	24030	83.0	8653	123.0	3526
4.0	75230	44.0	23384	84.0	8449	124.0	3452
5.0	72910	45.0	22758	85.0	8250		
6.0	70670	46.0	22150	86.0	8057		
7.0	68507	47.0	21561	87.0	7869		
8.0	66418	48.0	20989	88.0	7686		
9.0	64399	49.0	20435	89.0	7507		
10.0	62449	50.0	19896	90.0	7334		
11.0	60565	51.0	19374	91.0	7165		
12.0	58745	52.0	18867	92.0	7000		
13.0	56985	53.0	18375	93.0	6840		
14.0	55284	54.0	17898	94.0	6683		

SUCTION AND DISCHARGE TUBE BRAZING

Compliant Scroll compressors have copper plated steel suction and discharge tubes. These tubes are far more rugged and less prone to leaks than copper tubes used on other compressors. Due to different thermal properties of steel and copper, brazing procedures may have to be changed from those commonly used.

- To disconnect: heat joint Areas 2 and 3 slowly and uniformly until braze material softens and the tube can be pulled out of suction fitting. (See Figure 10.)

- To connect:
 - Recommended brazing materials: silfos with minimum 5% silver or silver braze material with flux.
 - Reinsert tube into fitting.
 - Heat tube uniformly in Area 1 moving slowly to Area 2. When joint reaches brazing temperature, apply brazing material. (See Figure 10.)
 - Heat joint uniformly around the circumference to flow braze material completely around the joint.
 - Slowly move torch into Area 3 to draw braze material into joint. (See Figure 10.)
 - **Do not** overheat joint.

FIGURE 13
BRAZING DIAGRAM

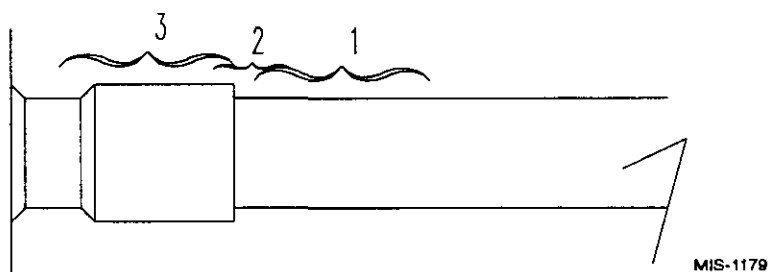

PRESSURE TABLES

TABLE 12

COOLING

Air Temperature Entering Outdoor Coil Degrees F

Model	Return Air Temperature	Pressure	75	80	85	90	95	100	105	110	115
PH11422	75 deg. DB	Low Side	74	75	77	78	79	80	81	82	83
	62 deg. WB	High Side	192	210	227	244	261	279	296	314	332
	80 deg. DB	Low Side	79	80	82	83	84	85	87	88	89
PH1048	67 deg. WB	High Side	197	215	233	250	268	286	304	322	340
	85 deg. DB	Low Side	85	86	88	89	90	91	94	95	96
	72 deg. WB	High Side	204	223	241	259	277	296	315	333	352
PH1060	75 deg. DB	Low Side	71	73	75	76	77	78	79	80	81
	62 deg. WB	High Side	211	226	243	258	276	293	310	329	347
	80 deg. DB	Low Side	76	78	80	81	83	84	85	86	87
PH1048	67 deg. WB	High Side	216	232	249	265	283	300	318	337	356
	85 deg. DB	Low Side	81	83	86	87	89	90	91	92	94
	72 deg. WB	High Side	224	240	258	274	292	311	329	349	368
PH1060	75 deg. DB	Low Side	65	66	68	69	70	71	72	73	74
	62 deg. WB	High Side	199	216	235	254	272	291	309	328	345
	80 deg. DB	Low Side	70	71	72	73	75	76	77	78	79
PH1048	67 deg. WB	High Side	204	222	241	260	279	298	317	336	354
	85 deg. DB	Low Side	75	76	77	78	80	82	83	84	85
	72 deg. WB	High Side	211	230	249	269	289	308	328	348	366

TABLE 13

HEATING

Air Temperature Entering Outdoor Coil Degrees F

Model	Return Air Temp.	Pressure	0	5	10	15	17	20	25	30	35	40	45	47	50	55	60
PH11422	70 deg	Low Side	17	19	21	26	29	33	38	45	49	52	55	56	58	61	64
		High Side	156	161	165	169	171	173	177	181	186	193	199	203	207	214	221
PH1048	70 deg	Low Side	25	27	29	31	32	34	36	38	40	47	54	56	60	67	73
		High Side	160	164	168	172	174	176	180	184	188	194	201	204	208	214	221
PH1060	70 deg	Low Side	17	19	21	24	26	29	33	37	41	46	50	52	55	59	64
		High Side	156	164	172	180	183	187	195	203	211	219	226	230	234	243	250

Low side pressure ± 2 PSIG
 High side pressure ± 5 PSIG

Tables are based upon rated CFM (airflow across the evaporator coil and should be found under section titled "Refrigerant Charge" elsewhere in manual. If there is any doubt as to correct operating charge being in the system, the charge should be removed, system evacuated, and recharged to serial plate instructions.

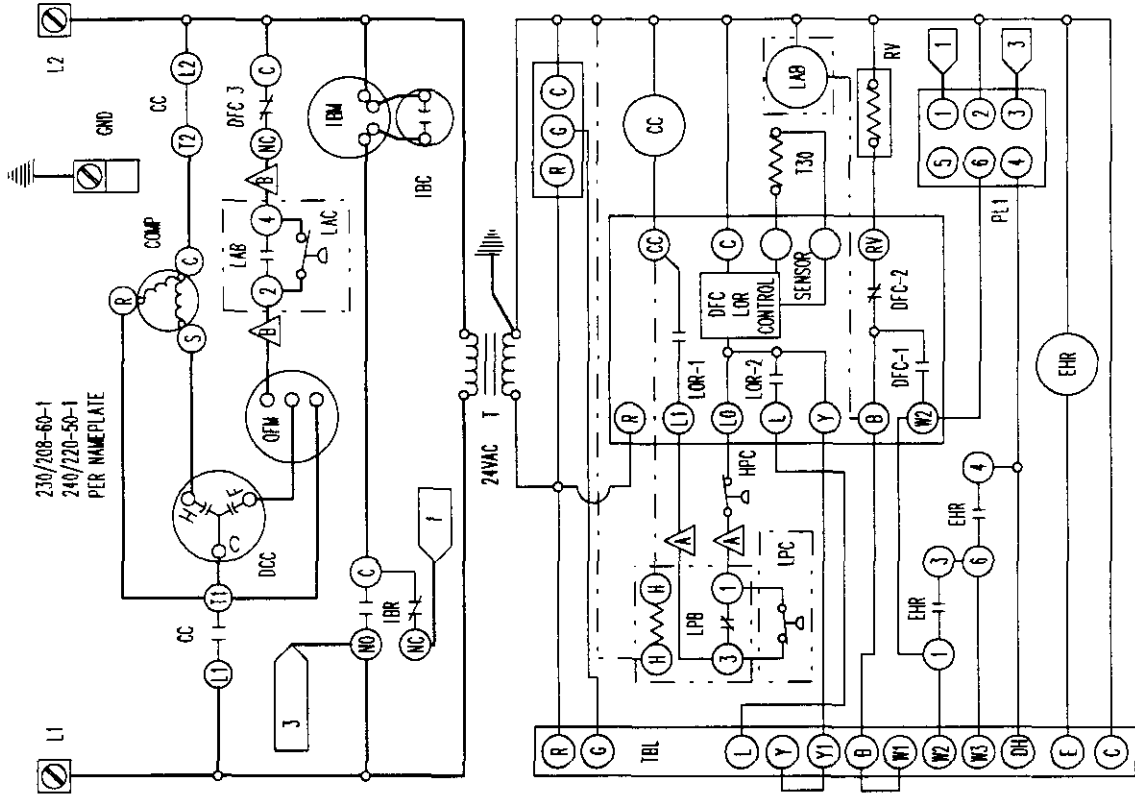

230/208-60-1
240/220-50-1
PER NAMEPLATE

USE COPPER CONDUCTORS ONLY
SUITABLE FOR AT LEAST 75° C

230/208-60-1
240/220-50-1
PER NAMEPLATE

COMPONENT CODE

CC
COMP
DCC
DFC
EHR
GND
HPC
IBM
IBR
IABC
LPB
LPC
OFM
PL
RV
T
TBL

LOW AMBIENT CONTROL
LOW PRESSURE BYPASS
LOW PRESSURE CONTROL
OUTDOOR FAN MOTOR
PLUG #1
REV. VALVE SOLENOID
TRANSFORMER
TERMINAL BLOCK
LOW VOLTAGE TERMINAL BLOCK

COMPRESSOR CONTACTOR
COMPRESSOR
DUAL CAN CAPACITOR
DEFROST CONTROL
EMERGENCY HEAT RELAY
EQUIPMENT GROUND
HIGH PRESSURE CAPACITOR
INDOOR BLOWER MOTOR
INDOOR BLOWER RELAY
LOW AMBIENT BYPASS CONTROL

230/208-60-1
240/220-50-1
PER NAMEPLATE

COMPONENT CODE

CC
COMP
DCC
DFC
EHR
GND
HPC
IBM
IBR
IABC
LPB
LPC
OFM
PL
RV
T
TBL

LOW AMBIENT CONTROL
LOW PRESSURE BYPASS
LOW PRESSURE CONTROL
OUTDOOR FAN MOTOR
PLUG #1
REV. VALVE SOLENOID
TRANSFORMER
TERMINAL BLOCK
LOW VOLTAGE TERMINAL BLOCK

COMPRESSOR CONTACTOR
COMPRESSOR
DUAL CAN CAPACITOR
DEFROST CONTROL
EMERGENCY HEAT RELAY
EQUIPMENT GROUND
HIGH PRESSURE CAPACITOR
INDOOR BLOWER MOTOR
INDOOR BLOWER RELAY
LOW AMBIENT BYPASS CONTROL

▲	LABELLED WIRES CONNECT IF NO OPTIONS USED.	▲	MOVE RED WIRE TO 208V TAP FOR 208V OPERATION	▲	RED (LOW) BLACK (HIGH) WHERE APPLICABLE
▲	▲	▲	▲	▲	▲
BK	BLACK	Y	YELLOW	V	VIOLET
BR	BROWN	G	GREEN	(PR)	PURPLE
R	RED	BL	BLUE	GY	GRAY
O	ORANGE	W	WHITE	(S)	SLATE
T	TAN	PK	PINK	L	LAVENDER
BARD MFG. CO.					
4066-114 C					

HIGH VOLTAGE	OPTIONAL
LOW VOLTAGE	OPTIONAL
ACCESSORY	OPTIONAL
FACTORY STD.	FIELD

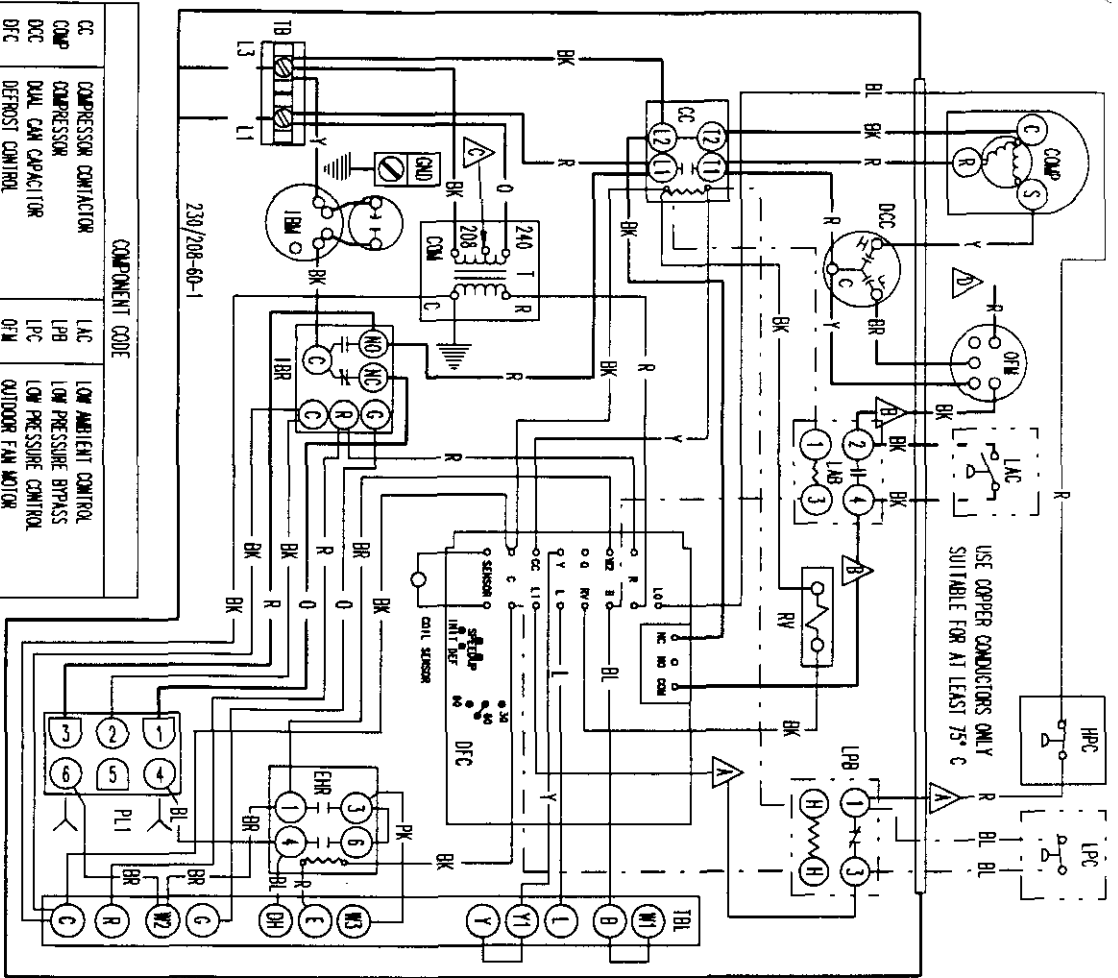

USE COPPER CONDUCTORS ONLY
SUITABLE FOR AT LEAST 75° C

COMPONENT CODE

CC	COMPRESSOR CONTACTOR	LAC	LOW AMBIENT CONTROL
CCP	COMPRESSOR	LFB	LOW PRESSURE BYPASS
DCC	DUAL CAM CAPACITOR	LPC	LOW PRESSURE CONTROL
DFC	DEFROST CONTROL	OFM	OUTDOOR FAN MOTOR
EHR	EQUIPMENT HEAT RELAY	PI1	PLUG #1
ECM	EQUIPMENT GROUND	RV	REV. VALVE SOLINOID
HPC	HIGH PRESSURE CONTROL	T	TERMINAL BLOCK
IBC	INDOOR BLOWER CAPACITOR	TB	LOW VOLTAGE TERMINAL BLOCK
IBM	INDOOR BLOWER MOTOR	TBL	LOW VOLTAGE TERMINAL BLOCK
IBR	INDOOR BLOWER BYPASS CONTROL		
LAB			

▲ Labeled wires connect if no options used.

▲ Move red wire to 208V tap for 208V operation

▲ Red (Low) Black (High) where applicable

FACTORY STD. FIELD OPTIONAL

HIGH VOLTAGE
LOW VOLTAGE
ACCESSORY

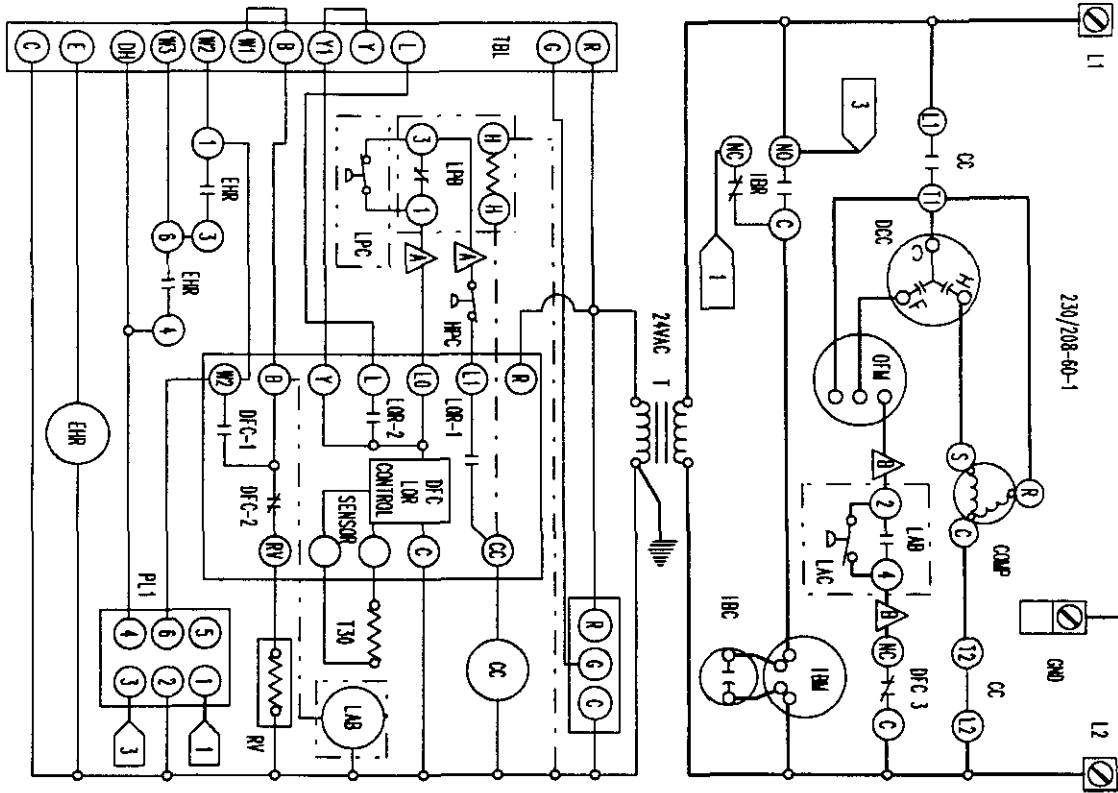

COLOR CODE

BK	BLACK	Y	YELLOW	V	VIOLET	T	TAN
BR	BROWN	G	GREEN	(PR)	PURPLE	PK	PINK
R	RED	BL	BLUE	CV	GRAY	L	LAVENDER
0	ORANGE	W	WHITE	(S)	SLATE		

BARDE MFG. CO.

4066-116

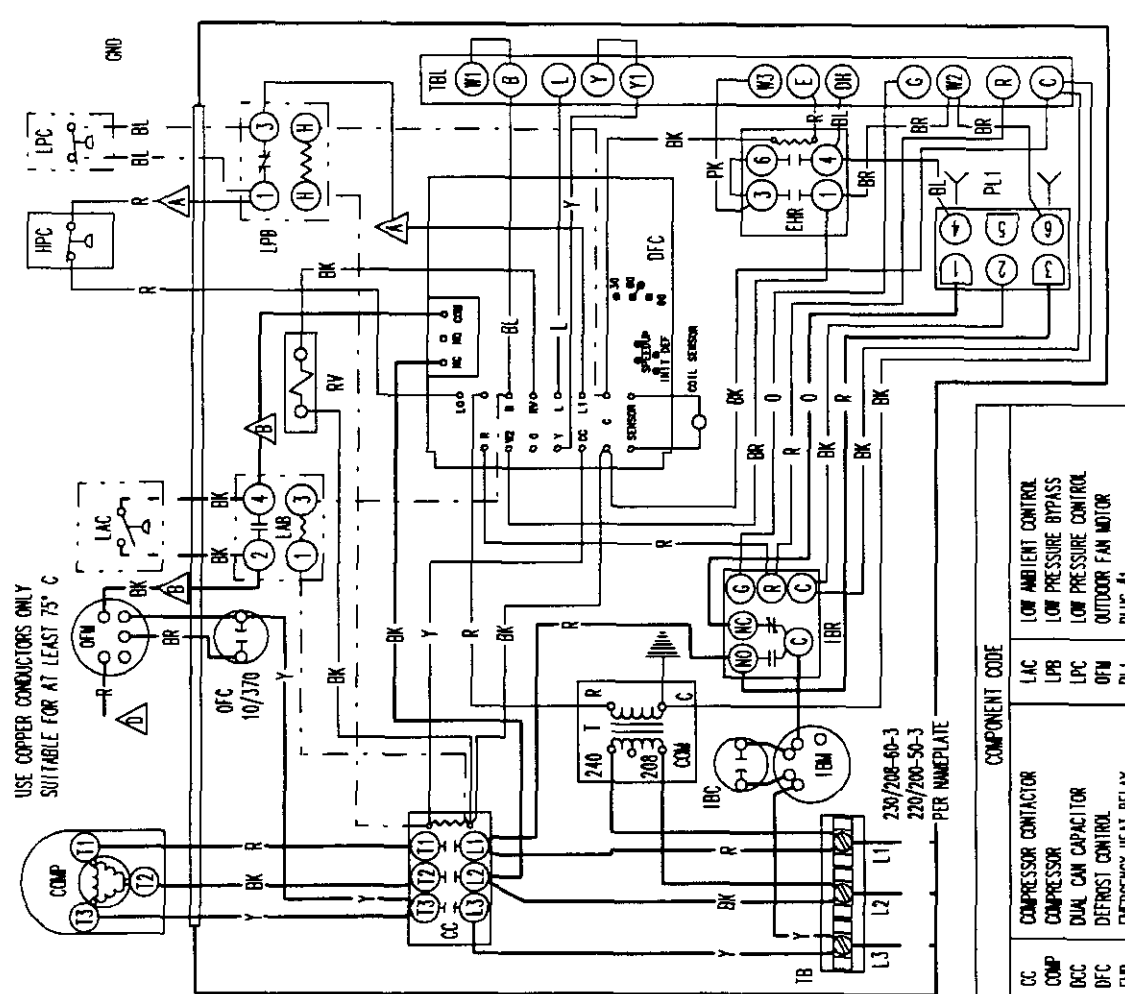
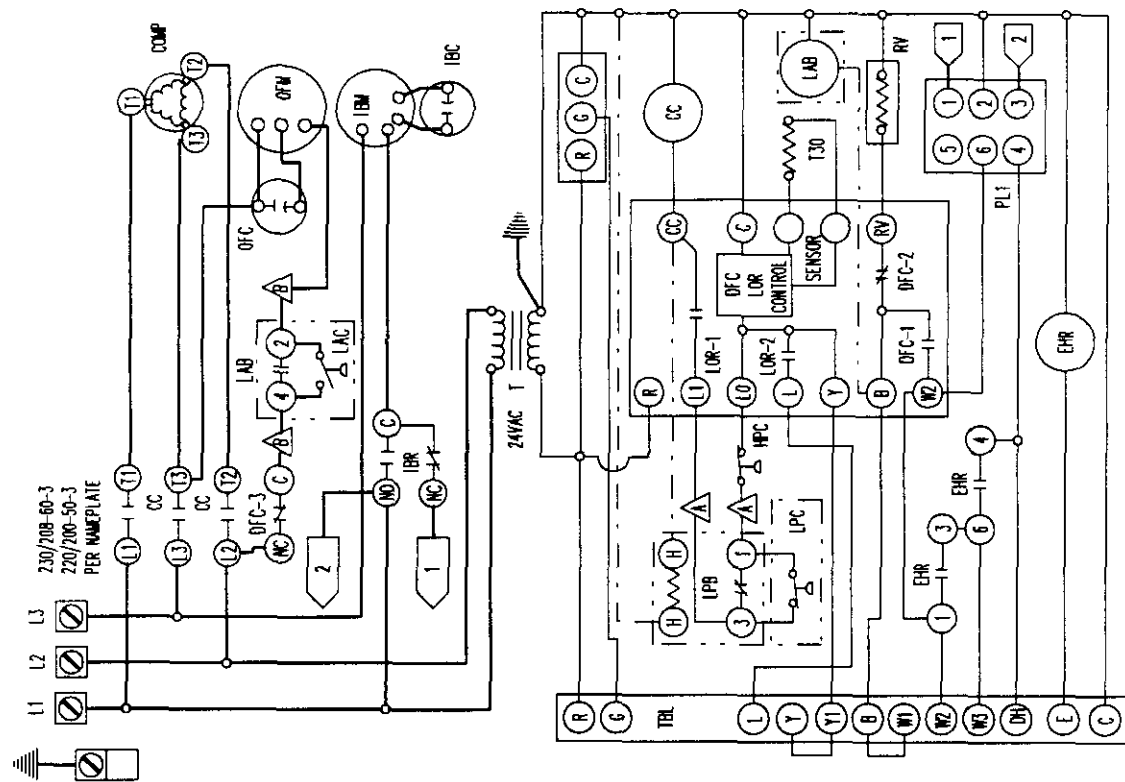

USE COPPER CONDUCTORS ONLY
SUITABLE FOR AT LEAST 75° C

230/208-60-3
220/200-50-3
PER NAMEPLATE

230/208-60-3
220/200-50-3
PER NAMEPLATE

COMPONENT CODE	COMPONENT CODE
CC	COMPRESSOR CONTACTOR
COMP	COMPRESSOR
DCC	DUAL CAN CAPACITOR
DFC	DEFROST CONTROL
GND	EMERGENCY HEAT RELAY
HPC	EQUIPMENT GROUND
IBC	HIGH PRESSURE CONTROL
IBM	INDOOR BLOWER MOTOR
IBR	INDOOR BLOWER RELAY
LAB	LOW AMBIENT BYPASS CONTROL
LAC	LOW AMBIENT CONTROL
LPB	LOW PRESSURE BYPASS
LPC	LOW PRESSURE CONTROL
OFW	OUTDOOR FAN MOTOR
PL1	PLUG #1
RV	REV. VALVE SOLINOID
TCT	TOP CAP THERMOSTAT
T	TRANSFORMER
TB	TERMINAL BLOCK
TBL	LOW VOLTAGE TERMINAL BLOCK

FACTORY STD.	FIELD	OPTIONAL	RED (LOW) BLACK (HIGH) WHERE APPLICABLE
HIGH VOLTAGE			
LOW VOLTAGE			
ACCESSORY			
BK	BLACK	Y	RED (LOW) BLACK (HIGH) WHERE APPLICABLE
BR	BROWN	C	
R	RED	BL	
O	ORANGE	W	
		V	
		Y	
		G	
		GRN	
		PR	
		BLU	
		W	
		VI	
		PUR	
		GRY	
		SLT	
		TAN	
		PNK	
		LAV	

BARDE MFG. CO.
4066-211 B

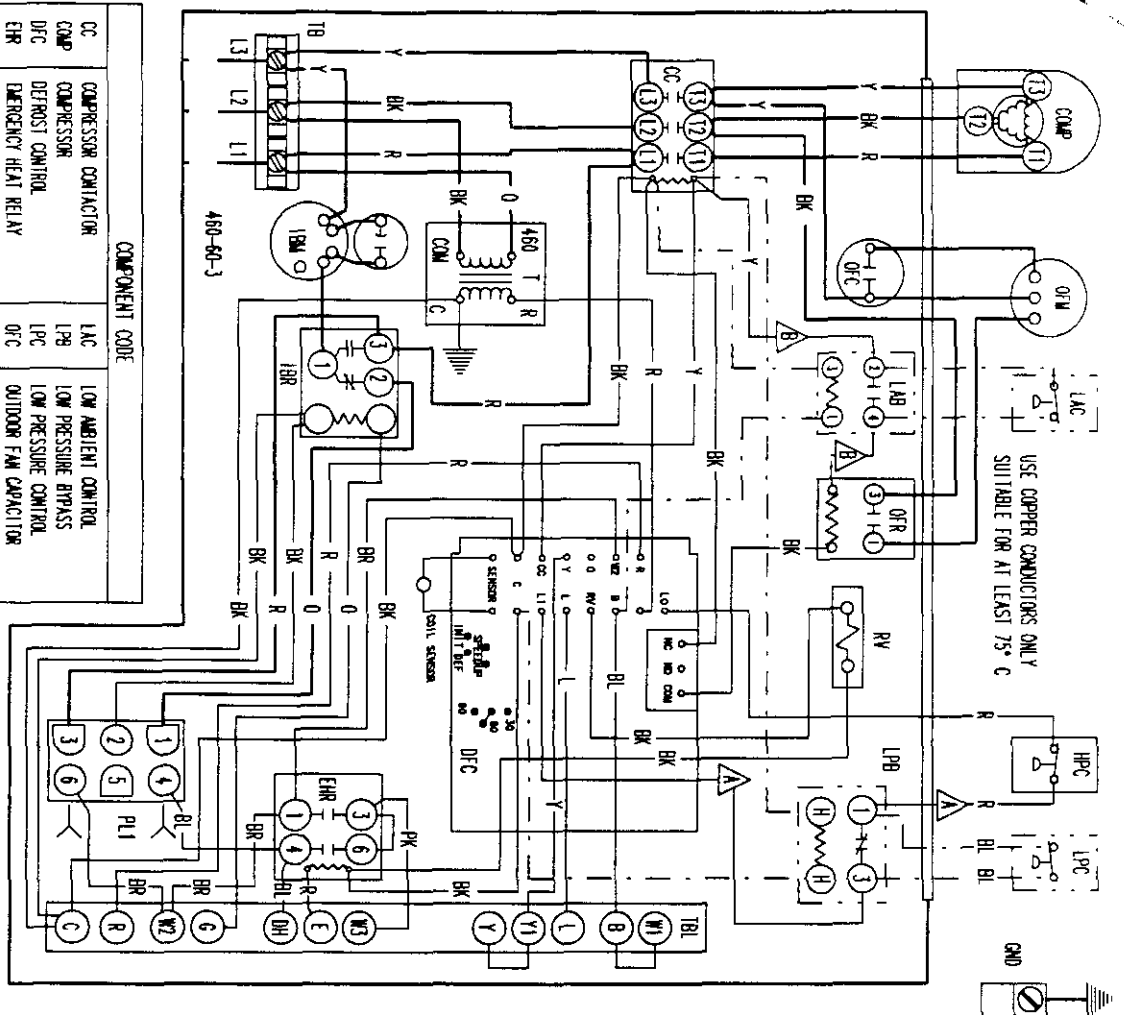

USE COPPER CONDUCTORS ONLY
SUITABLE FOR AT LEAST 75° C

COMPONENT CODE

CC	COMPRESSOR CONTACTOR	LAC	LOW AMBIENT CONTROL
COMP	COMPRESSOR	LFB	LOW PRESSURE BYPASS
DFC	DEFROST CONTROL	LPC	LOW PRESSURE CONTROL
ERR	EMERGENCY HEAT RELAY	DFC	OUTDOOR FAN CAPACITOR
EQD	EQUIPMENT GROUND	DFM	OUTDOOR FAN MOTOR
HPC	HIGH PRESSURE CONTROL	DFR	OUTDOOR FAN RELAY
IBC	INDOOR BLOWER CAPACITOR	PLC #1	REV. VALVE SOLINOID
IBM	INDOOR BLOWER MOTOR	RV	TRANSFORMER
IBR	INDOOR BLOWER RELAY	TB	TERMINAL BLOCK
LAB	LOW AMBIENT BYPASS CONTROL	TBL	LOW VOLTAGE TERMINAL BLOCK

△ Labeled wires connect if no options used.

FACTORY STD. FIELD OPTIONAL

HIGH VOLTAGE ACCESSORY	---	---	---
LOW VOLTAGE ACCESSORY	---	---	---

△ RED (LOW) BLACK (HIGH) WHERE APPLICABLE

COLOR CODE

BK	BLACK	Y	YELLOW	V	VIOLET	T	TAN
BR	BROWN	G	GREEN	(PR)	PURPLE	PK	PINK
RD	RED	B	BLUE	GY	GRAY	L	LANDER
OR	ORANGE	W	WHITE	(S)	SLATE		

BARO MFG. CO.

4066-311 C

