

INSTALLATION INSTRUCTIONS HIGH EFFICIENCY GAS FURNACE

READ ALL INSTRUCTIONS CAREFULLY BEFORE BEGINNING THE INSTALLATION.

THE INSTALLATION MUST COMPLY WITH THESE INSTRUCTIONS AND THE REQUIREMENTS OF ALL GOVERNING CODES AND ORDINANCES FOR THE INSTALLATION LOCATION.

IT IS THE RESPONSIBILITY OF INSTALLER TO KNOW AND UNDERSTAND ALL OF THESE REQUIREMENTS.

FAILURE TO DO SO COULD CREATE A HAZARD RESULTING IN PROPERTY DAMAGE, BODILY INJURY OR DEATH.

MODELS: *LO-BOY*

DCL065D36D

DCL080D48D

DCL095D60D

DCL110D60D

IMPORTANT NOTICE

THIS FURNACE IS NOT INTENDED FOR USE AS A CONSTRUCTION HEATER.

USE OF THIS FURNACE DURING CONSTRUCTION AND FINISHING PHASES OF A STRUCTURE IS CONSIDERED AS "OPERATION IN A CORROSIVE ATMOSPHERE" and "UNUSUAL, NEGLIGENT OR IMPROPER USE" AND AS SUCH ARE CONSIDERED EXCLUSIONS BY THE BARD MANUFACTURING COMPANY LIMITED WARRANTY

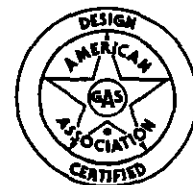

Manual: 2100-329
SUPERSEDES
FILE VOL. I, TAB 2
DATE: 06-19-98

Contents

Section	Page		Page
1 Getting Other Information and Publications ...	1	Figures	
2 Important Safety Precautions	2	Figure 1	5
3 Meeting Codes	2	Figure 2	6
4 Application	3	Figure 3	7
5 Sizing of Furnace	3	Figure 4	9
6 Locating the Furnace	4	Figure 5	10
7 Duct Work	4	Figure 6	10
8 Electrical, Gas, Drain and Supply Air Duct Connections	6	Figure 7	11
9 Ventilator Air	7	Figure 8	12
10 Vent and Combustion Air Intake Piping System Design	7	Figure 9	14
11 Joining Pipe and Fittings	11	Figure 10	15
12 Vertical Venting	12	Figure 11	17
13 Horizontal Venting	13	Figure 12	18
14 Venting Resizing Instructions (Replacement Furnaces Only)	16	Figure 13	24
15 Condensate Drain	17	Figure 14	25
16 Condensate Pump and Neutralizer	17	Figure 15	26
17 Gas Supply and Piping	17	Figure 16	27
18 Checking Gas Input	19	Figure 17	29
19 Gas Pressure Specifications	20	Figure 18	33
20 Standard Orifice Sizing and High Altitude Derate	20	Figure 19	36
21 Wiring Specifications	23	Wiring Diagram	37
22 Thermostat	23		
23 Blower Operation	28	Tables	
24 Air Filters	29	Table 1	4
25 Lighting and Operation Instructions	30	Table 2	5
26 Sequence of Operations	31	Table 3	6
27 Integrated Furnace Control (IFC)	31	Table 4	8
28 Accessory Wiring	33	Table 5	14
29 Routine Maintenance Instructions	34	Table 6	18
30 Servicing Furnace	34	Table 7	18
31 Replacement Parts	36	Table 8	19
		Table 9	20
		Table 10	21 & 22
		Table 11	22
		Table 12	23
		Table 13	28
		Table 14	29
		Table 15	32

Section 1 – Getting Other Information and Publications

These publications can help you install the furnace. You can usually find these at your local library or purchase them directly from the publisher. Be sure to consult current edition of each standard.

National Fuel Gas Code ANSI Z223.1 / NFPA 54

National Electrical Code ANSI / NFPA 70

Standard for the Installation of ANSI / NFPA 90A
Air Conditioning and Ventilating Systems

Standard for Warm Air Heating ANSI / NFPA 90B
and Air Conditioning Systems

Standard for Chimneys, Fireplaces, Vents, NFPA 211
and Solid Fuel Burning Appliances

Load Calculation for Residential ACCA Manual J
Winter and Summer Air Conditioning

Duct Design for Residential Winter ACCA Manual D
and Winter Air Conditioning and Equipment Selection

For more information, contact these publishers:

ACCA — Air Conditioning Contractors of America
1712 New Hampshire Avenue, NW
Washington, DC 20009
Telephone: (202) 483-9370

ANSI — American National Standards Institute
11 West Street, 13th Floor
New York, NY 10036
Telephone: (212) 642-4900
Fax: (212) 302-1286

**ASHRAE — American Society of Heating Refrigerating,
and Air Conditioning Engineers, Inc.**
1791 Tullie Circle, NE.
Atlanta, GA 30329-2305
Telephone: (404) 636-8400
Fax: (404) 321-5478

NFPA — National Fire Protection Association
Batterymarch Park
P.O. Box 9101
Quincy, MA 02269-9901
Telephone: (800) 344-3555
Fax: (617) 984-7057

COPYRIGHT JUNE 1998
BARD MANUFACTURING COMPANY
BRYAN, OHIO 43506 USA

SECTION 2 – IMPORTANT SAFETY PRECAUTIONS

WARNING

Read and exactly follow these rules. Failure to do so could cause improper furnace operation resulting in damage, injury or death



2.A HAZARD ALERT SYMBOL

An exclamation point surrounded by a triangle.

2.B SIGNAL WORDS

Years of safe, dependable service are assured when you understand and follow all safety precautions. **REMEMBER:** Your furnace contains flames, gas, electricity, rotating parts and metal edges.

Signal words “**WARNING**” and “**CAUTION**” alert you to potential hazards.

“**WARNING**” alerts you to a potentially hazardous situation which, if not avoided, could result in property damage, serious injury or death.

“**CAUTION**” alerts you to a potentially hazardous situation which, if not avoided, may result in minor or moderate injury. It may also be used to alert against unsafe practices. It can also be used to signal property damage only potential.

To help you, we use the words “must” and “should” in this manual. “Must” is mandatory. “Should” is advisory.

“**IMPORTANT**” is used to draw your attention to information that is high priority.

2.C PRECAUTIONS

1. Use only the type of gas approved for this furnace. Refer to furnace rating plate.

WARNING

Only use natural gas in furnaces designed for natural gas. Only use propane (LP) gas for furnaces designed for propane (LP) gas. Make sure furnace will operate properly on gas type available to user. Do not use this furnace with butane. Using wrong gas could create a hazard resulting in property damage, injury, or death.

2. **Do not** install this furnace outdoors or in a mobile home, trailer, or recreational vehicle. It is not AGA design-certified for these installation. This furnace is suitable for a home built on site or manufactured home completed at final site. See Section 4 for more information.
3. Carefully choose furnace installation site. **Do not** directly expose furnace to drafts, wind or other outdoor conditions.
4. **Do not** install furnace in a corrosive or contaminated atmosphere. See Section 4 for more information.
5. **Do not** use this furnace during construction when adhesives, sealers, and/or new carpets are being installed. See Section 4 for more information.
6. Provide adequate ventilation air to space where furnace is being installed. See Section 9 for more information.
7. Connect this furnace to an approved vent and combustion air intake system. See Section 10 for more information.
8. **Never** test for gas leaks with an open flame. Use a commercial soap made specifically for leak detection to check all connections. See Section 17 for more information.
9. **Always** install duct system with furnace. Be sure duct system has external static pressure within allowable furnace range. See Section 7 for more information.
10. Completely seal supply and return air ducts to furnace casing. Duct work must run to an area outside furnace air space. Seal duct work wherever it runs through walls, ceilings or floors. See Section 7 for more information.

SECTION 3 – MEETING CODES

Before installing furnace, make sure you know all applicable codes. National, state and local codes may take precedence over any instructions in this manual. Be sure to consult the following safety standards.

- Authorities having jurisdiction over furnaces
- Local code authorities for information on electrical wiring, gas piping and vent pipe.
- Current National Fuel Gas Code ANSI/NFPA 54
- Current National Electrical Code ANSI/NFPA 70.

See Section 1 for information on getting copies of these codes.

SECTION 4 – APPLICATION

This is a fan-assisted Category IV forced air direct vent gas furnace for indoor installation in building constructed on site. The furnace installation must conform with local building codes and ordinances or, in their absence with the National Fuel Gas Code, ANSI Z223.1-latest edition and the National Electrical Code, ANSI/NFPA 70 - latest edition. It is the personal responsibility and obligation of the purchaser to contract a qualified installer to assure that installation is adequate and is in conformance with governing codes and ordinances.

*** IMPORTANT NOTICE ***

THIS FURNACE IS NOT INTENDED FOR USE AS A CONSTRUCTION HEATER.

USE OF THIS FURNACE DURING CONSTRUCTION AND FINISHING PHASES OF A STRUCTURE IS CONSIDERED AS "OPERATION IN A CORROSIVE ATMOSPHERE" AND "UNUSUAL, NEGLIGENT OR IMPROPER USE" AND AS SUCH ARE CONSIDERED **EXCLUSIONS** BY THE BARD MANUFACTURING COMPANY LIMITED WARRANTY.

When a furnace is used as a construction heater, it is operated under unusual and abnormal conditions that can cause condensation to occur in some portions of the DCL-series furnaces that will not condense *under normal operation* conditions when properly sized, installed, and set up for operation.

Combined with condensation problems are the many sources of chloride that are present in high concentrations during construction phases of a structure. These chloride sources are either very reduced or the vapors have left once the construction activities are completed and the structure is ready to occupy.

Many of the more common construction sources of chlorides are listed below, and they are usually present in large quantities.

Cement/Concrete Mixtures	Adhesives
Paint	Tile/Counter Cements
Stain, Varnish	Cements and Glues
Solvents	Dust Particles
Wood Preservatives	Foam Insulation
Floor Sealers	

SECTION 5 – SIZING OF FURNACE

The sizing of high efficiency gas furnaces for both new and replacement installations is critical due to condensing design of the appliances. Oversizing of the furnace for any application can cause short cycling (short on-time) conditions, and this in turn permits condensate to occur in locations within the furnace where it was not intended to be.

It is a normal occurrence for some condensate to form in the upper areas of the primary heat exchanger and in the combustion air blower section of the furnace on start up. As the furnace attains normal operating conditions, these areas dry up, and all condensing takes place in the secondary stainless steel heat exchanger.

Short cycling of the furnace permits condensate to form in some areas and never dry up. This continuously wet condition can lead to corrosion and metal deterioration causing premature failure of those components.

The following guidelines must be used to properly size and select the furnace for all applications:

1. Always conduct an accurate heating load calculation using appropriate methods, typically Air Conditioning Contractors of America (ACCA) Manual J.
2. Always use the correct outdoor and indoor design temperatures for the area; the actual dimensional information for the structure; the correct insulation values for windows, doors, wall and ceilings. Make sure that the correct values are used for the tightness of the building and that all other characteristics are input correctly into the calculation. There is no need to *inflate* or *adjust* any of these values *just to make sure* the furnace will be large enough. There is adequate safety factor built into Manual J, and any deviation from real or actual values will cause a potentially gross oversizing.
3. Always make the furnace selection based upon the useful heat rating of the furnace expressed as heating capacity or output Btu/h. Never use input capacity.
4. Never make a furnace selection based upon the size of the previous furnace. It was undoubtedly grossly oversized to begin with, and very probably energy efficiency improvements were done to the structure over time further reducing the Btu requirement.
5. The DCL series high efficiency gas furnaces are available in four heating output capacities. A nominal 15 percent oversizing and 10 percent undersizing rule should be used in determining which furnace should be installed. Table 1 will assist in furnace selection.

It is important to remember that furnace selections are made based upon the winter outdoor design conditions, and that very few hours of operation per year are at or near that temperature. And when the outdoor temperature is at the winter design condition, a correctly sized furnace will be operating the majority of the time with few and/or short off cycles.

TABLE 1

Furnace Output Rating	Calculated Heat Loss Range (Btuh)
DCL065	50,001 - 63,000
DCL080	63,001 - 75,000
DCL095	75,001 - 92,000
DCL110	92,001 - 110,000

Approximately 85 percent of the operating time of a typical furnace is when the building heat loss is only 10-80 percent of the winter design heat loss rating of the building, so it is essential *not to oversize the furnace* by either having an *inflated calculated heat loss* and/or *picking one size larger furnace than calculated just to be sure.*

SECTION 6 – LOCATING THE FURNACE

When selecting a location for the furnace, observe the following guidelines.

1. The furnace should be set on a level floor. If the floor may become damp or wet at times, the furnace should be supported above the floor using a concrete base, bricks, patio blocks, etc., making sure adequate support is available for the furnace. Furnace approved for installation on combustible flooring shall not be installed directly on carpeting, tile or other combustible material other than wood flooring.
2. The furnace should be as centralized as is practical with respect to the air distribution system.
3. The vent and air intake pipe should be as short as practical but must be at least 8 feet and no more than 65 feet in total equivalent length from furnace to the outside termination point. See Section 10 for more information.
4. Provide at least the minimum clearances specified in Table 2 on page 5 for fire protection, proper operation and service access. These clearances must be permanently maintained. The ventilating air opening in the front of the furnace must never be obstructed.
5. All models are approved for either closet or alcove installation. An alcove is similar to a closet except there is no door permitted to enclose the front of furnace. See Table 2 for approved installation.
6. Fresh air for combustion must be piped from the outside of the building to the connection on the burner enclosure. See Section 10 for more information.
7. Minimum service clearances must take precedence over fire protection clearance (minimum installation clearances.)

8. A gas fired furnace installed in a residential garage must be installed so that the burners and ignition source are located not less than 18 inches above the floor, and the furnace must be located or protected to avoid physical damage by vehicles.
9. This furnace must be installed as to protect all electrical components from exposure to condensation and/or water.

CAUTION

Do not locate furnace where temperature may drop below freezing as condensate may freeze resulting in improper operation or furnace damage.

WARNING

Do not store combustible materials near furnace or warm air ducts. The material may ignite by spontaneous combustion creating a fire hazard.

SECTION 7 – DUCT WORK

INADEQUATE SUPPLY AIR AND/OR RETURN AIR DUCT SYSTEMS

Short cycling because of limit control operation can be created by incorrectly designed or installed supply and/or return air duct systems.

The duct systems must be designed using ASHRAE or ACCA design manuals, and the equipment cfm and external static pressure ratings to insure proper air delivery capabilities.

On replacement installations, particularly if equipment is oversized, the duct systems may be undersized. Modifications may be required to assure that the equipment is *operating within the approved temperature rise range when under full input conditions*, and that no short cycling on limit controls is occurring.

For installation of furnaces *not* equipped with cooling units*, the outlet duct must be provided with a removable access panel. This opening must be accessible after the furnace is installed and shall be of such a size that the heat exchanger can be inspected for possible leaks. The access panel must be attached in a manner to prevent leakage.

**TABLE 2
MINIMUM CLEARANCES (INCHES)**

Minimum Installation Clearances											Minimum Service Clearances			(2) Minimum Ventilation Openings For Confined Spaces -- Square Inches Of Free Area
Model	Type Of Installation	Furnace				Plenum		(1) Duct	Vent Pipe	Floor	Front	Back	Sides	
		Front	Back	Left Side	Right Side	Top	Sides							
DCL065	Closet	4	0	0	0	1	1	1	0	C	24	24	18 (3)	100 (2 required)
DCL080	Closet	4	0	0	0	1	1	1	0	C	24	24	18 (3)	100 (2 required)
DCL095	Closet	4	0	0	0	1	1	1	0	C	24	24	18 (3)	100 (2 required)
DCL110	Closet	4	0	0	0	1	1	1	0	C	24	24	18 (3)	100 (2 required)

(1) For the first three feet from plenum. After the first three feet, no clearance required.

(2) See Section 9 – Ventilation Air – for additional information

(3) Required for access to rear of furnace to service blower compartment and air filters.

C Floor may be combustible material



WARNING

When a furnace is installed so that supply ducts carry air circulated by the furnace to areas outside the space containing the furnace, the return air must also be handled by a duct(s) sealed to the furnace casing and terminating outside the space containing the furnace. This is to prevent drawing possibly hazardous combustion products into the circulated air which can result in bodily injury or death.

When the furnace is used in connection with a cooling unit*, the furnace shall be installed parallel with or on the upstream side of the cooling unit to avoid condensation in the heating element. With a parallel flow arrangement, the dampers or other means used to control flow of air shall be adequate to prevent chilled air from entering the furnace, and if manually operated must be equipped with means to prevent operation of either unit unless the damper is in the full heat or cool position.

* A cooling unit is an air conditioning coil, heat pump coil or chilled water coil.

**FIGURE 1
FURNACE LOCATED IN CONFINED SPACE**

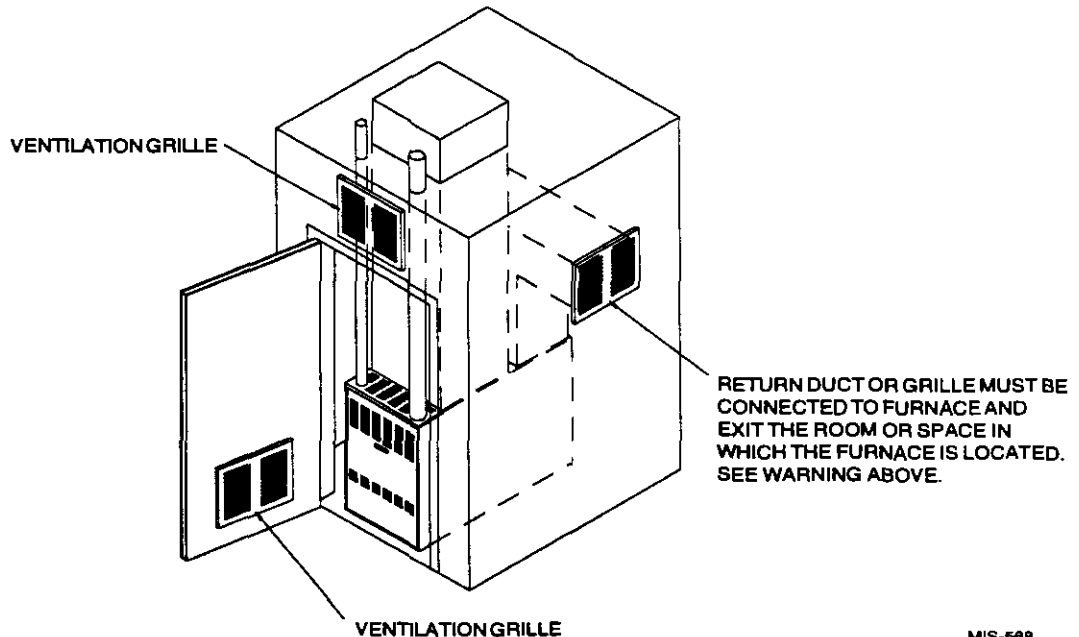

MIS-588

SECTION 8 – ELECTRICAL, GAS, DRAIN AND SUPPLY AIR DUCT CONNECTIONS

Shown in Figure 2 are the electrical, gas and drain entrance/exit locations available on the furnace. There is an optional left or right side entrance/exit point for the gas piping, condensate drain tubing, 115V electrical supply, 24V thermostat wiring, and optional accessory wiring harness for field supplied and installed electronic air cleaner and humidifier. Care should be taken when converting to any of the optional access points to ensure all wiring is safely kept from all moving parts and sharp edges.

For attachment of supply air duct system, there are two methods provided:

1. If optional cooling coil cabinet is used, it will fit over the 20" connection depicted in Figure 2. The coil cabinets are designed to accommodate the standard A-coil evaporator sections.

2. If the optional coil cabinet is not used, installing a plenum 21" deep x the required width and using the forward plenum flange 21" from back flange will better facilitate later installation of the A-coil evaporator sections which have a 20-1/2" pan dimension.

The 20" dimension can be used but would require an offset cover door be fabricated to accommodate the 20-1/2" A-coil dimension if decided to install at a later date.

**TABLE 3
SUPPLY AIR DUCT CONNECTIONS**

Model	If Coil Cabinet Is Used W x D	If No Coil Cabinet Is Used W x D
DCL065	18 x 20	18 x 21
DCL080 DCL095	22 x 20	22 x 21
DCL110	25 x 20	25 x 21

FIGURE 2

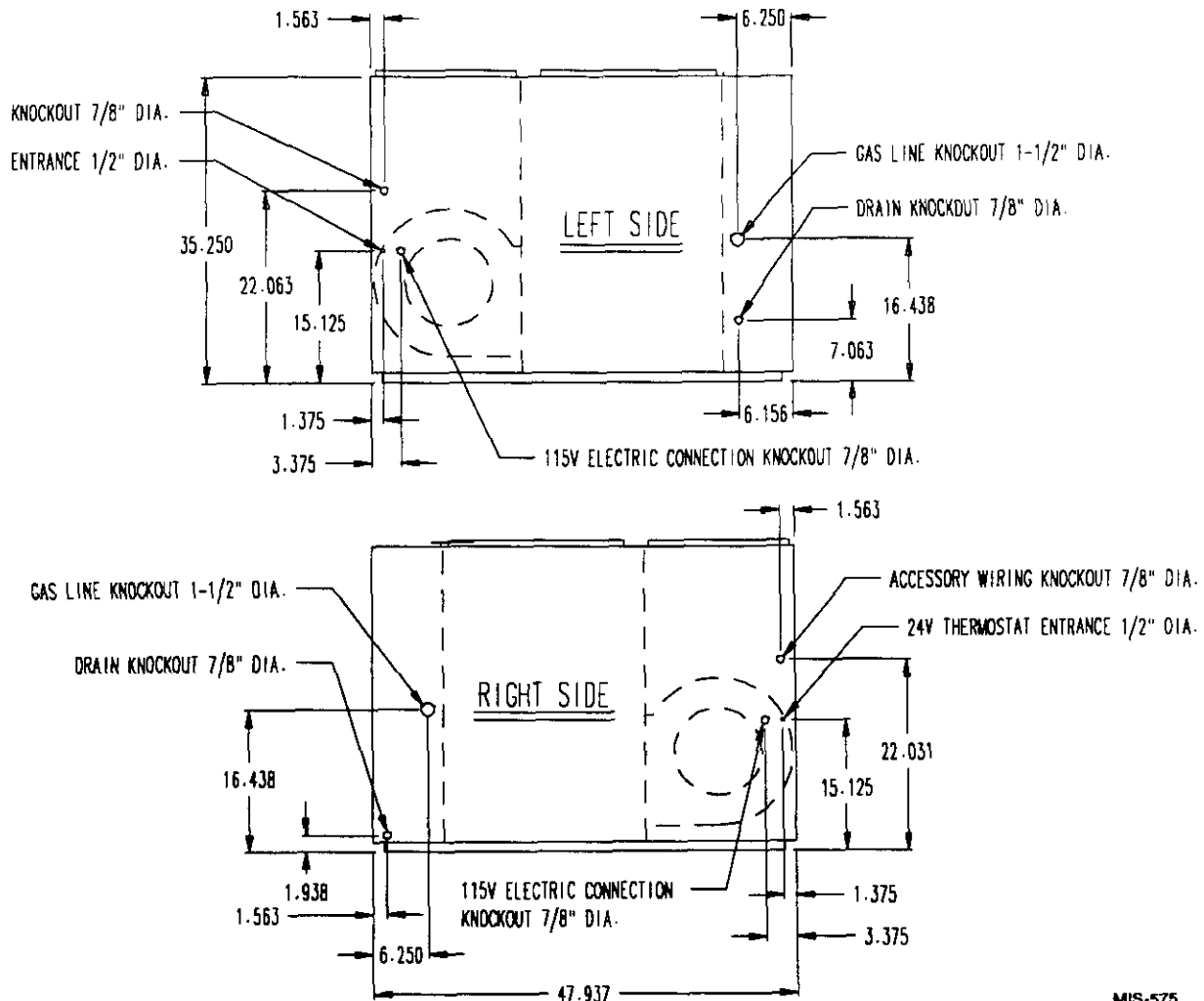

MIS-575

SECTION 9 – VENTILATION AIR

If the furnace is installed in a closet or utility room, ventilating air must be allowed to enter the room through two permanent openings of equal area. One opening shall be located within twelve (12) inches of the ceiling and one opening within twelve (12) inches of the floor. Each opening shall have a face area of 100 square inches minimum of free area. If grilles are used, the opening will need to be larger to provide the 100 square inches of free area due to the grille restriction. Consult grille catalog to determine free area of various grilles. See Figure 1 for more information.

SECTION 10 – VENT AND COMBUSTION AIR INTAKE PIPING SYSTEM DESIGN

This furnace must have the flue gases vented outside and the combustion air supply piped in from the outside using round PVC (polyvinyl chloride ASTM D-2665/D1785) or ABS (acrylonitrile-butadiene-styrene ASTM F628-91 foam core or ASTM D-2661 solid) Schedule 40 pipe and fittings. See Table 4 for vent and air intake pipe sizing outside of the furnace. Both vent and air intake pipes must be the same size (diameter), and neither is to exceed the total length shown in Table 4. See Figure 5 for specifics on piping within the furnace cabinet and on making the connections to the furnace. See Figure 6 for details on upsizing the piping at top of furnace if required by Table 4.

*** IMPORTANT NOTICE ***

Both the vent and combustion air intake piping must be installed in the same orientation; either vertical or horizontal as described in following instructions. It is not permissible to run one vertically and the other horizontally.

This furnace must use outside air for combustion. Failure to connect the air intake to the outside may result in premature failure of the heat exchanger(s), and will also affect operation whenever there are any wind conditions. The orientation shown in Figure 8 for horizontal (sidewall) installation is essential to prevent nuisance cycling of the furnace on the pressure switch during extremely windy conditions. Connection of the air intake is a requirement for limited lifetime warranty of primary and secondary heat exchanger to be in effect.

This furnace removes both sensible and latent heat from the combustion flue gases. Removal of latent heat results in condensation of flue gas water vapor. This condensed water vapor drains from the secondary heat exchanger into a 29-4C stainless steel drain pan. The condensate exits the drain pan by means of 3/8 I.D. vinyl hose. See Section 15 for drain information.

FIGURE 3

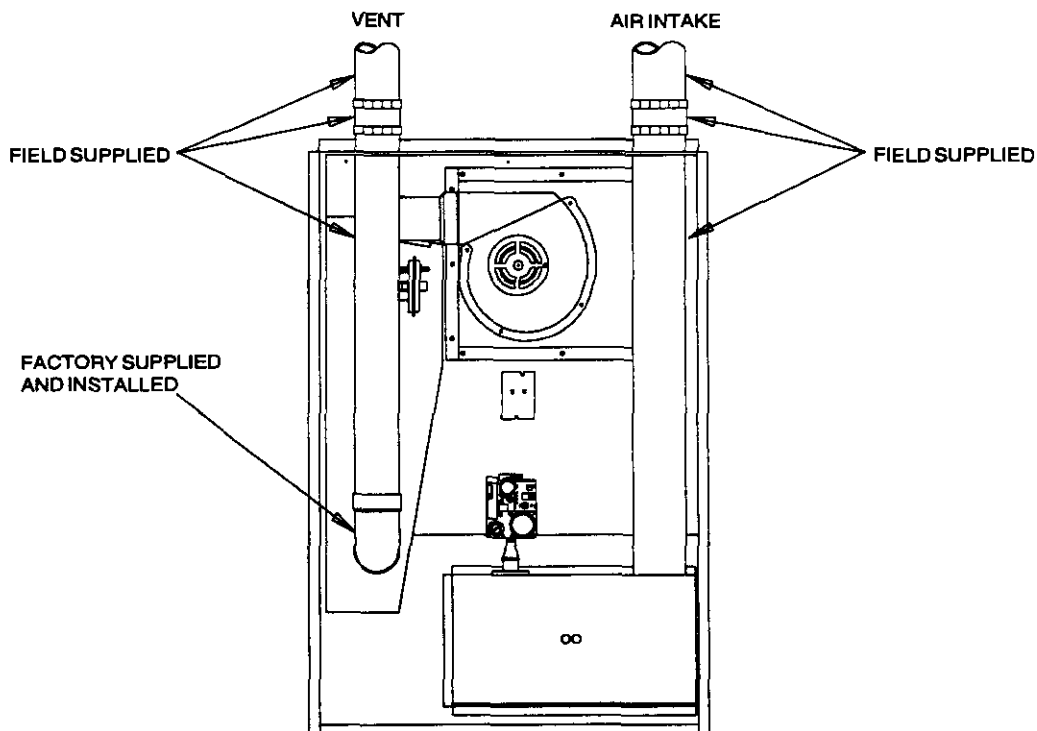

MIS-574

***** IMPORTANT NOTICE *****

For *horizontal* vent systems see special *vent termination* information in Section 13.

TABLE 4

PROPER VENT AND AIR INTAKE SELECTION

Furnace Models	Minimum Maximum Vent & Air Intake Length and Size (1)
DCL065	8 ft. – 30 ft. x 2", or 8 ft. – 65 ft. x 2-1/2", or 8 ft. – 65 ft. x 3"
DCL080, or DCL095	8 ft. – 65 ft. x 3"
DCL110	8 ft. – 65 ft. x 4"

(1) Vent length is in equivalent feet measurement. Refer to Item 1, General Instructions below.

This vent must be in accordance with Part 7, Venting of Equipment, of the National Fuel Gas Code, ANSI Z223-1 - latest edition, and Addenda Z223.1a - latest edition, or applicable provisions of the local building codes.

 **CAUTION**

Each vent must serve only one furnace. Connecting more than one furnace to a vent system will cause one or both furnaces to malfunction.

 **WARNING**

Do not connect vent to an existing masonry chimney or vent. Failure to adhere to this warning can result in property damage, bodily injury, or death.

GENERAL INSTRUCTIONS

1. The maximum length in equivalent feet for vent and air intake piping system is shown in Table 4 with each 45° elbow counting as 2-1/2 feet and each 90° elbow counting as 5 feet. Do not count the factory supplied 2" street elbow supplied installed on the furnace or the field supplied piping *inside* the furnace cabinet in the equivalent footage calculation. Drainage type (long radius) elbows should be used. Pressure type (short radius) 90° elbows count as 10 equivalent feet.

IMPORTANT: Some models require a different size pipe *inside* the furnace cabinet itself. See Figure 5 for details.

Example: 20 feet of straight vent pipe with three (3) 90° long radius elbows equals 35 equivalent feet.

2. All pipe and fittings *external* of the furnace cabinet may be PVC or ABS as desired. The field supplied vent pipe section between factory supplied street elbow and the top of the furnace may be PVC or ABS (ABS required on DCL110 model.) (See Figure 5.)
3. Minimum horizontal piping length is 3 feet and 1 elbow.
4. A maximum of five (5) 90 degree elbows are permitted in the piping system.
5. Pipe diameter must not be reduced except as detailed for sidewall vent terminal.
6. Horizontal vent (exhaust) piping must slope upwards not less than 1/4 inch per foot to permit good flow of condensate from interior wall of piping back to the furnace. Horizontal air intake piping supplying combustion air is not critical with regard to slope *except* that the section that passes through exterior wall should have slight, downward slope to the outside to help assure no rainwater can enter and drain back towards the furnace.
7. All horizontal pipe runs must be supported at least every 4 feet with metal pipe strapping. No sags or dips or low spots are permitted.
8. Do not install the piping system in the same chase with a vent from another gas or other fuel burning appliance. However, if two DCL models are used, both piping systems may be installed in the same chase with each other.
9. For any sections of the piping system in free air, do not install the pipe within 6 inches of a single wall vent pipe (2 inch B-vent) from another gas or other fuel burning appliance.
10. The piping system can be run in the same chase or adjacent to supply or vent pipe for water supply or waste plumbing.
11. The vent pipe must be insulated if there is any chance of condensate freezing inside the pipe. This can occur if the vent pipe passes through an unconditioned space such as attic, crawl space, un-insulated chase or a masonry chimney. It can also occur where the vent terminates above the roof or if an exterior vertical riser (Figure 4) is used to get above snow levels. Local climatic conditions and vent length must be considered. If vent height above roof exceeds 12 inches because of snow accumulation, it must be insulated.

FIGURE 4

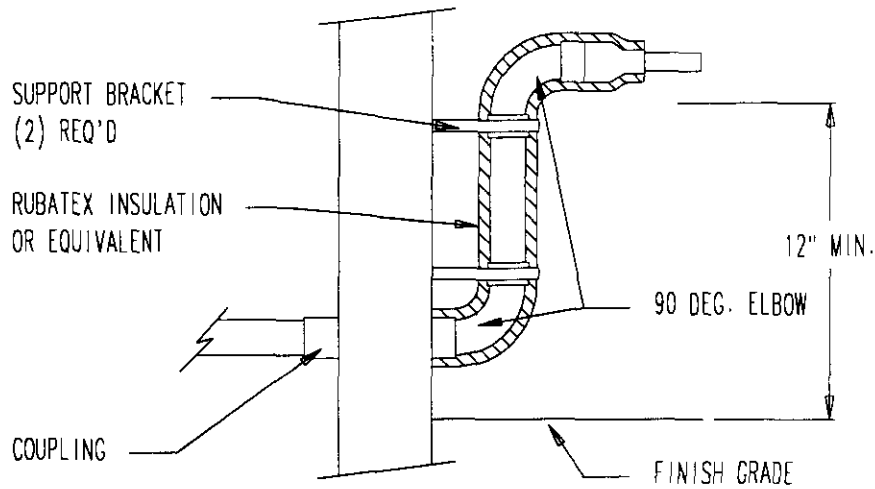

MIS-325

NOTE 1 If installation requires rise greater than 30" above grade, an alternate exit location or interior vertical vent/air intake system should be used. (See Figure 4.)

NOTE 2 Brackets should be designed to securely hold and position riser piping to prevent movement in any direction, including back towards wall. (See Figure 4.)

***** IMPORTANT NOTICE *****

Short cycling conditions by pressure switch operation can be created by vent system installations that have too much restriction (pressure drop) because of too many elbows, excess equivalent feet length, improper slope on horizontal runs, sag or low spots in horizontal piping sections creating condensation collection points, or incorrect vent terminal application or location.

TYPES OF INSULATION

FOR INDOOR OR OUTDOOR USE

Rubatex or Armaflex closed cell foam, or equal. Recommended thickness is one inch. Addition layers may be required for extreme cold climate conditions.

FOR INDOOR USE ONLY

Fiberglass insulation with vapor barrier, or equal. Recommended thickness of one inch up to ten feet. Two inch thickness if unconditioned exposure exceeds ten feet.

CONNECTING PIPING SYSTEM TO THE FURNACE

The furnace is shipped from the factory with a 2" street ell installed in the furnace vestibule.

The vent is constructed in the field by installing the 2" PVC (ABS required on DCL110, optional on other models) pipe into the 2" street ell factory installed in the furnace. For furnaces requiring larger vent systems due to the length requirement, the 2" piece of pipe is only used within the cabinet. Once out of the cabinet, the correct vent size is used by means of a reducing fitting. No-hub connectors are recommended at top of furnace for ease of any service requirements at a later date.

The PVC (ABS optional) air intake pipe connects directly to the burner box. Install the pipe over the short section of aluminum tubing that is crimped to the burner box.

See Figure 5 for details on making both connections to the furnace.

See Figure 6 for details on upsizing the piping system as required by Table 4.

See Figure 7 for details on how to use two 45° elbows to offset air intake pipe to provide clear access to add-on air conditioning coil refrigerant lines and condensate drain connections.

FIGURE 5
VENT AND AIR INTAKE PIPING SYSTEM SIZES
AND TYPE EXTERNAL TO CABINET

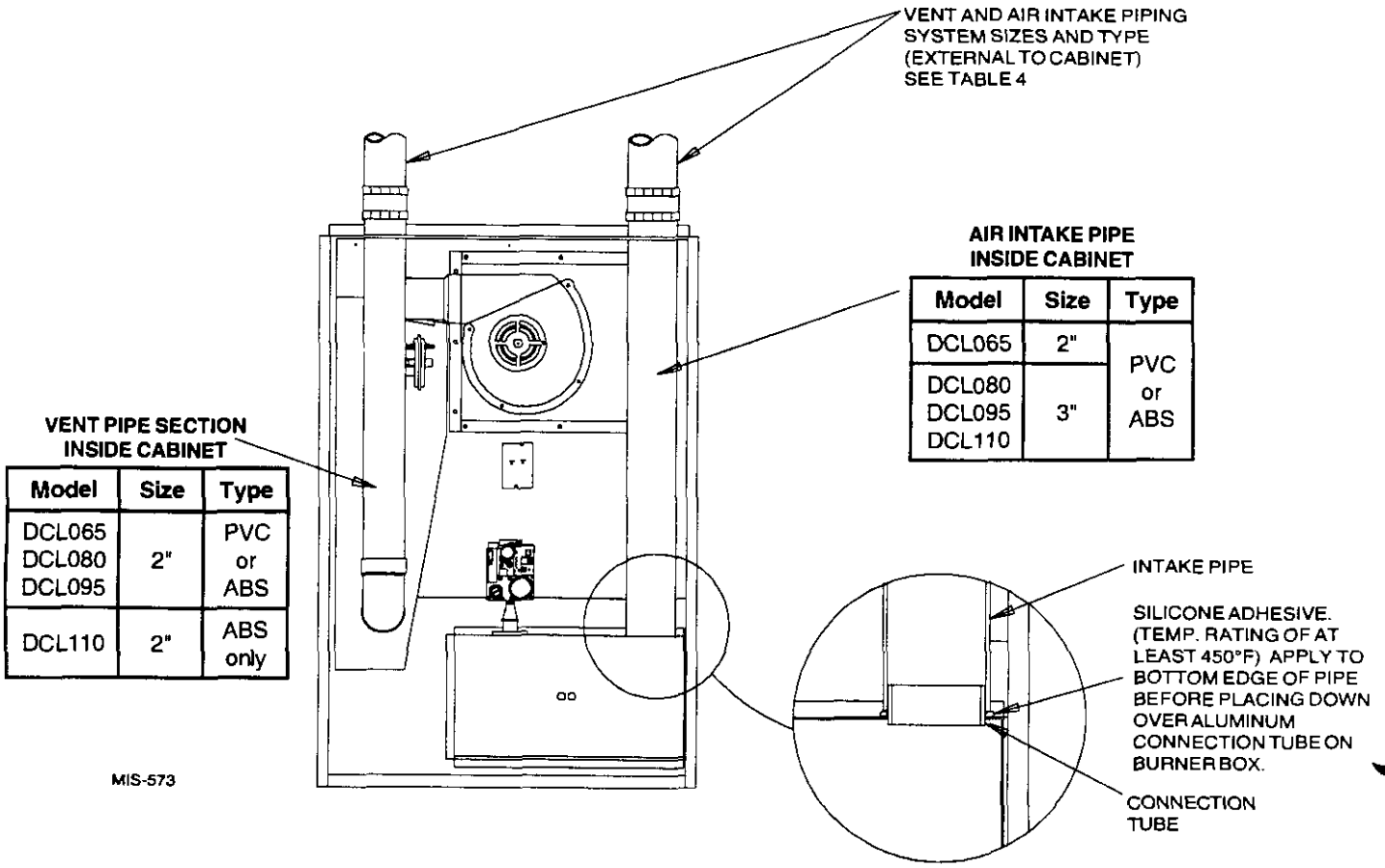

MIS-573

FIGURE 6
RECOMMENDED METHODS FOR VENT AND AIR INTAKE PIPE
UPSIZING AT TOP OF FURNACE

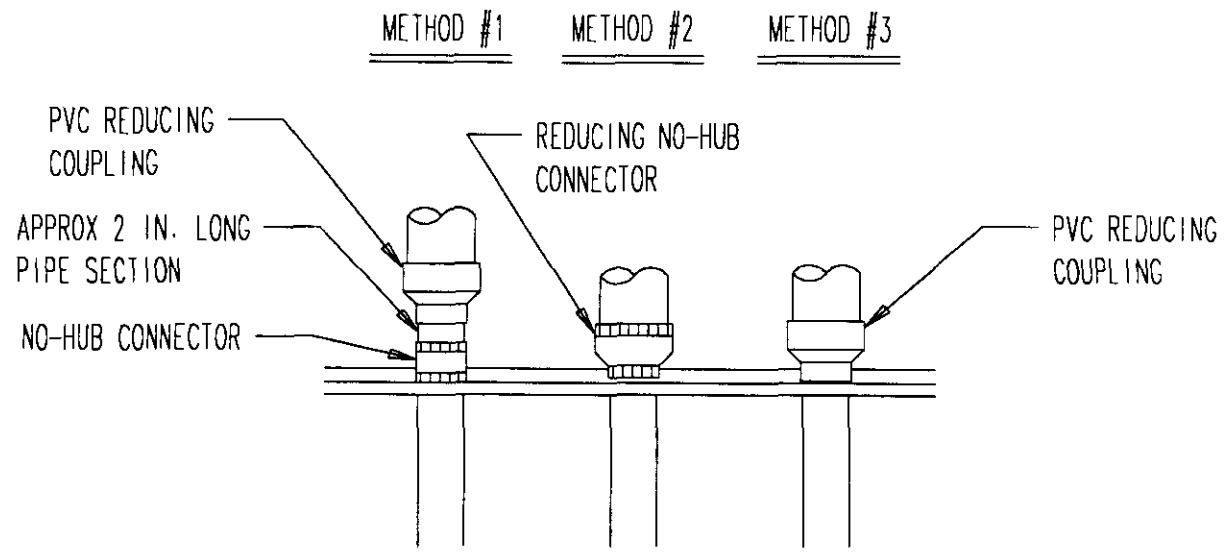

MIS-322

NOTE: METHODS #1 OR #2 RECOMMENDED FOR EASE OF SERVICE

FIGURE 7

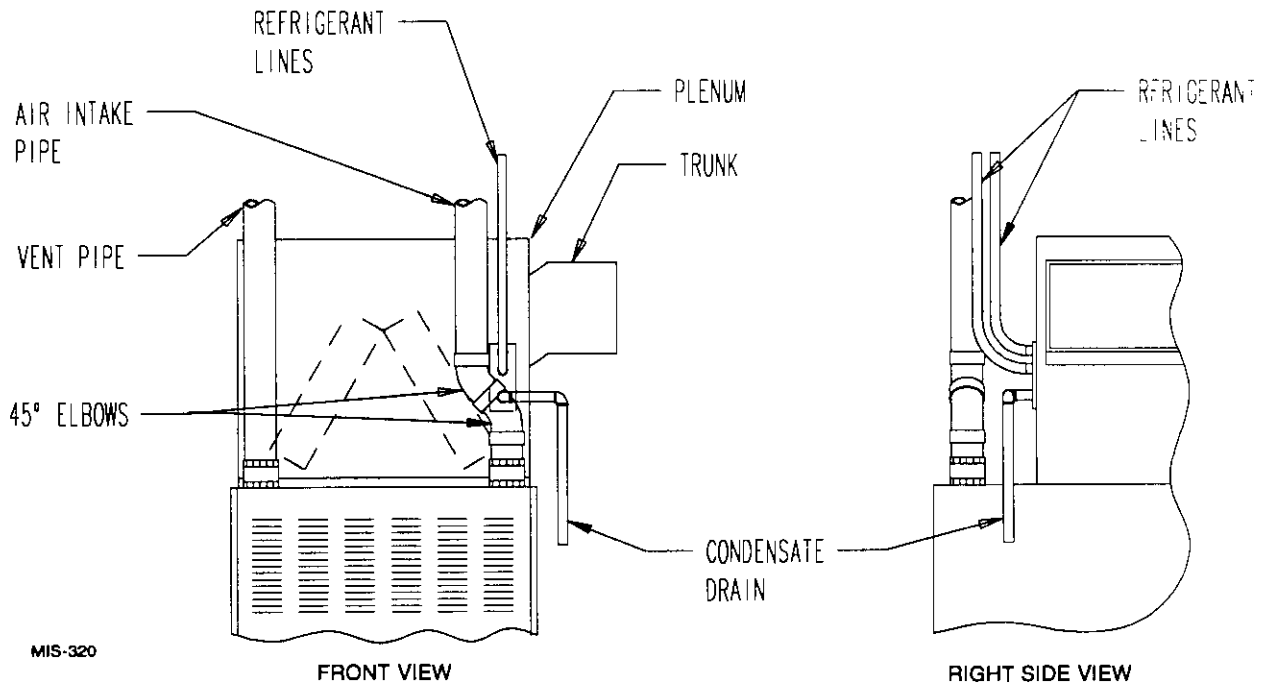

SECTION 11 – JOINING PIPE AND FITTINGS

All pipe, fitting, solvent cement, primers and procedures must conform to American National Standard Institute and American Society for Testing and Materials (ANSI/ASTM) standards.

PIPE AND FITTINGS

All connections must be made using cleaner-primer and all purpose solvent cement rated to ASTM Standards D-2564, D-2846 and D-2235

All joints in the piping system must be properly sealed using the following material and procedure:

*** IMPORTANT NOTICE ***

FOR PROPER INSTALLATION:

Do not use solvent cement that has become curled, lumpy or thickened.

Do not thin. Observe shelf precautions printed on containers.

For applications below 40° F use only low temperature type solvent cement.

WARNING

When using cleaner-primer and all purpose solvent cement

- Danger of fire or bodily injury
- Solvent cements and primers are highly flammable.
- Provide adequate ventilation and **do not** assemble near heat source or open flame. **Do not** smoke.
- Avoid skin or eye contact. Observe all cautions and warnings printed on material containers.

1. Cut pipe end square, remove ragged edges and burrs. Chamfer end of pipe, then clean fitting socket and pipe joint area of all dirt, grease or moisture.
2. After checking pipe and socket for proper fit, wipe socket and pipe with cleaner-primer. Apply a liberal coat of primer to inside surface of socket and outside of pipe. **Do not allow primer to dry before applying cement.**
3. Apply a thin coat of cement evenly in the socket. Quickly apply a heavy coat of cement to the pipe end and insert pipe into fitting with a slight twisting movement until it bottoms out.

NOTE: *Cement must be fluid, if not, recoat.*

4. Hold the pipe in the fitting for 30 seconds to prevent the tapered socket from pushing the pipe out of the fitting.
5. Wipe all excess cement from the joint with a rag. Allow 15 minutes before handling. Cure time varies according to fit, temperature and humidity.

NOTE: Stir the solvent cement frequently while using. Use a natural bristle brush or the dauber supplied with the can. The proper size is one inch.

SECTION 12 – VERTICAL VENTING

A typical vent installation is shown in Figure 8.

1. When vent penetrates through the roof and is brought above anticipated snow level, the pipe should be cut off on a 45° angle. This will help prevent freezing and blockage of the vent system.

2. The air intake pipe should have two 90° elbows installed with opening on bottom to prevent water entrance. A bird screen is provided to insert into open end of elbow.
3. Bird screens are provided. See Figure 8 for installation detail. Use of these is recommended.
4. Vent pipe running through an unconditioned space must be insulated. See "Types of Insulation" in Section 10.
5. An interior masonry chimney can be used as a chase as long as steps 8 and 9 under General Instructions are followed.
6. If an exterior masonry chimney is used as a raceway or chase, the vent piping must be insulated. See "Types of Insulation" in Section 10. If a B-vent for a water heater is also run up through the same chimney, a minimum of one inch clearance from the insulation to the B-vent must be maintained at all points.
7. For either an interior or exterior chimney, the top of the chimney must be sealed with a metal cap to prevent cold air from blowing into the chimney and surrounding the vent pipe(s).

**FIGURE 8
TYPICAL VERTICAL VENTING INSTALLATION**

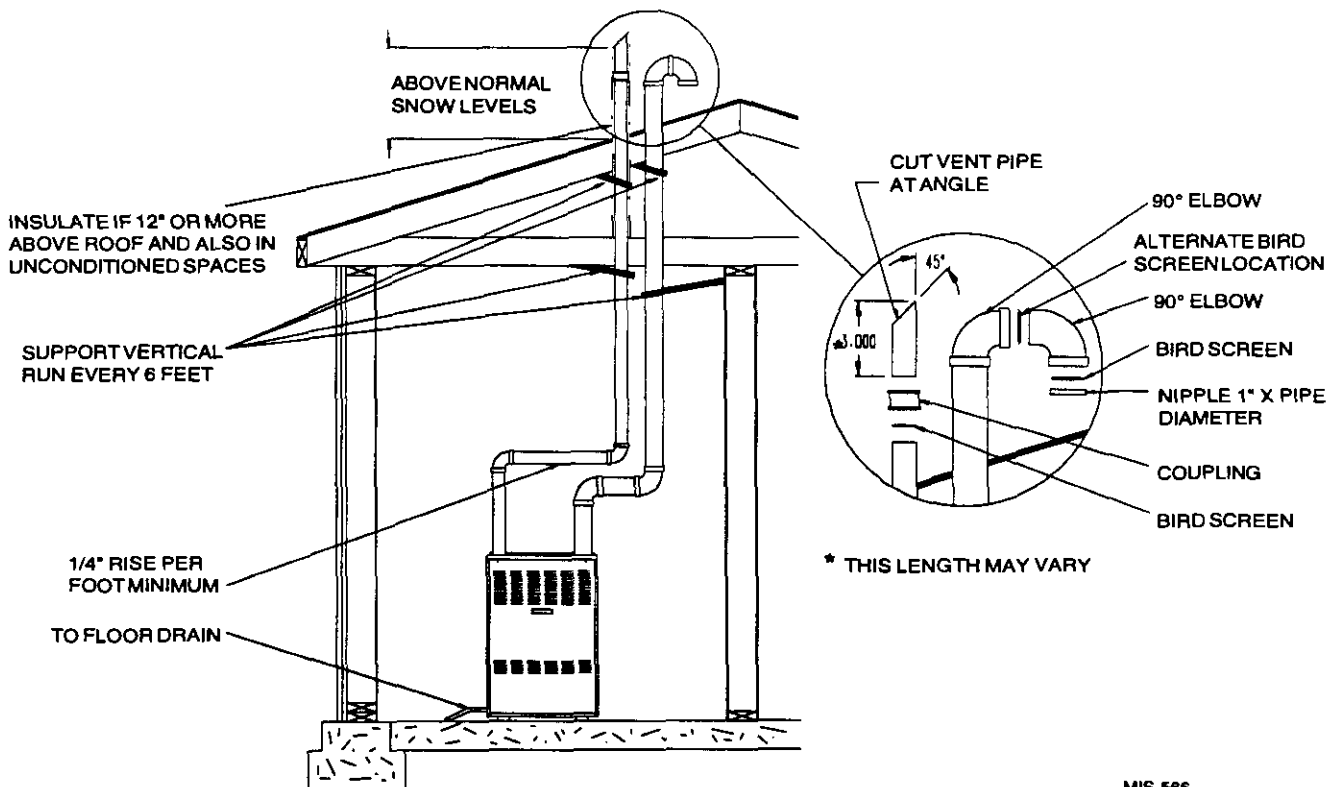

MIS-566

SECTION 13 – HORIZONTAL VENTING

The furnace may be vented horizontally through an outside wall using all of the applicable instructions under Vent Pipe Installation with these additional requirements. The requirements and limitations for Horizontal Venting are very strict. *All horizontal vent installations must be made in accordance with these instructions.*

VENT AIR INTAKE TERMINAL LOCATION

The vent and air intake terminal location must meet the requirements listed in the following instructions or applicable codes, whichever specifies the most clearance or strictest limitation. See Table 5 for sizing requirements.

Location	Clearance Feet
Above grade level or above anticipated snow depth	1
Dryer Vent	3
Gas appliance vent terminal	3
From any mechanical fresh air intake	1
From any non-mechanical air supply or combustion air opening	1
From service regulator vent, electric and gas meters, and relief equipment	4 (1)
Above grade when adjacent to public walkway	7

(1) See Item 6 in Section 13.

*** IMPORTANT NOTICE ***

The combustion products and moisture in the flue gases may condense as they leave the terminal fitting. The condensate may freeze on the exterior wall, under the eaves and on surrounding objects. Some discoloration to the exterior of the building may occur.

CAUTION

As a natural part of the unit's operation, normal products of combustion, including water vapor are vented to the atmosphere. Since the outside air temperature can be well below 32°F, it is possible that the water vapor in the exhaust will freeze causing an ice buildup around the discharge opening of the pipe. During periods of extremely cold weather and prolonged operation of the furnace, this ice buildup could become quite large. The manufacturer does not recommend the installation of these units in locations above frequent vehicular and/or pedestrian traffic. The ice buildup could present a potentially hazardous situation if it becomes dislodged.

The manufacturer will *not* be held responsible for any injury or property damage resulting from any improper installation.

LOCATION REQUIREMENTS – HORIZONTAL (SIDEWALL) INSTALLATION

The vent and air intake terminal must be installed with the following minimum clearances and requirements:

1. The vent and air intake terminals must be located not less than 10 inches or more than 20 inches on center line. The two terminals must be in a side by side relationship to one another within this requirement. See Figure 9
2. Bird screens are provided for vent and air intake terminals. See Figure 10 for installation detail. Use of these screens is recommended.
3. 12 inches minimum above ground level, and above anticipated normal snow levels. See Figure 10.

NOTE: Ice or snow may cause the furnace to shut down if the vent or air intake becomes obstructed. If required, use a vertical riser or shield vent and air intake to prevent blockage from drifting snow. See Figure 4. All fittings and pipe for riser must be included in total equivalent feet calculation. Refer to Section 10, General Information, Item 1.

4. Not above the walkway or area that may cause a hazard or nuisance, or be detrimental to the operation of other equipment.
5. One foot minimum from and not above or below any door, window, gravity inlet or forced air inlet for the building.
6. Four feet minimum horizontal clearance from electric meters, gas meters, and regulators.
7. At least one foot from any soffit or under eaves vent.
8. Do not vent under any kind of patio or deck.

9. Locate vent and air intake terminal on the side of the building away from prevailing winter winds when practical. Roof termination is preferred.
10. Do not locate too close to shrubbery as condensate may stunt or kill them.
11. The vent terminal must be located a minimum of 12 inches away from any opening in which flue product could enter a building.
12. Use protective measures such as shielding and/or sealing cracks, seams, and joints of building materials to prevent damage from condensation. A rust resistant shield behind vent terminal may be required. The shield must measure a minimum of 9" from the center of the vent terminal in all directions.

**FIGURE 9
HORIZONTAL VENT AND AIR INTAKE
TERMINAL ORIENTATION**

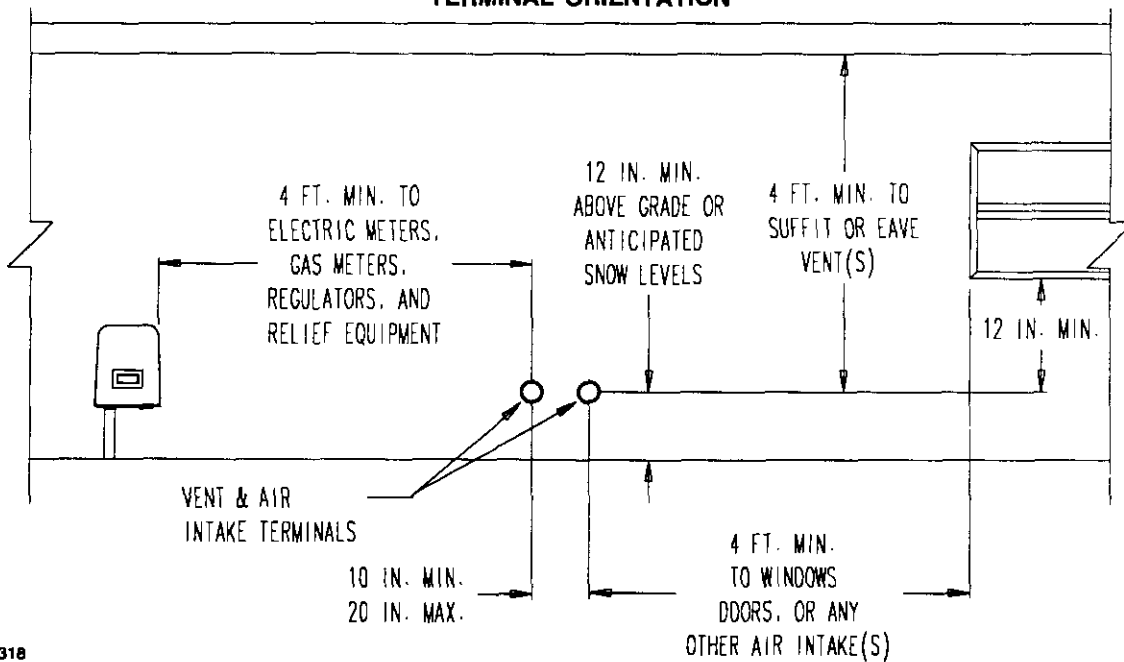

MIS-318

**TABLE 5
VENT AND AIR INTAKE TERMINALS
(See Figure 10)**

Pipe Size (A) Note 1	Air Intake Terminal		Vent Terminal		
	Tee (B)	Bird Screen (C)	Reducing Coupler (D)	Nozzle Tube (E)	Bird Screen (F)
2"	2"	2-3/8" O.D.	2" x 1-1/2"	1-1/2" x 4"	2-3/8" O.D.
2-1/2"	2-1/2"	2-7/8" O.D.	2-1/2" x 2"	2" x 4"	2-1/2" O.D.
3"	3"	3-1/2" O.D.	3" x 2"	2" x 4"	3-1/2" O.D.
4"	4"	4-1/2" O.D.	4" x 3"	3" x 7"	4-1/2" O.D.

Note 1: Pipe size determined from Table 4

FIGURE 10

AIR INTAKE TERMINAL

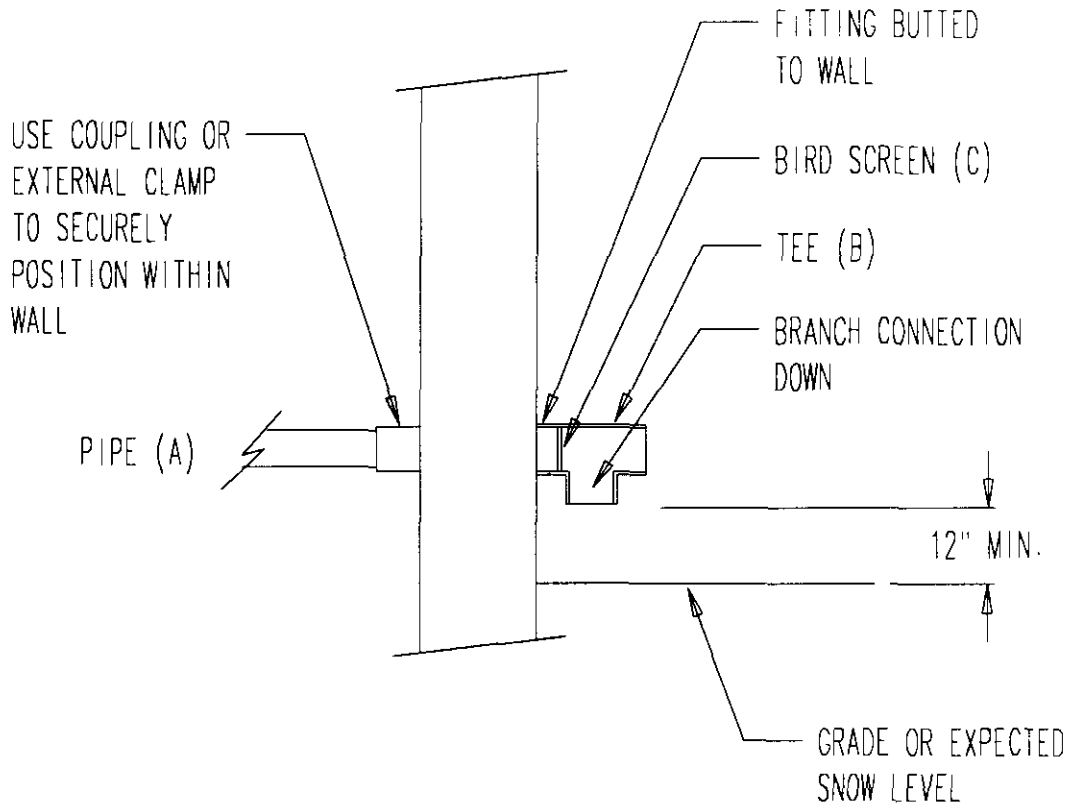

VENT TERMINAL

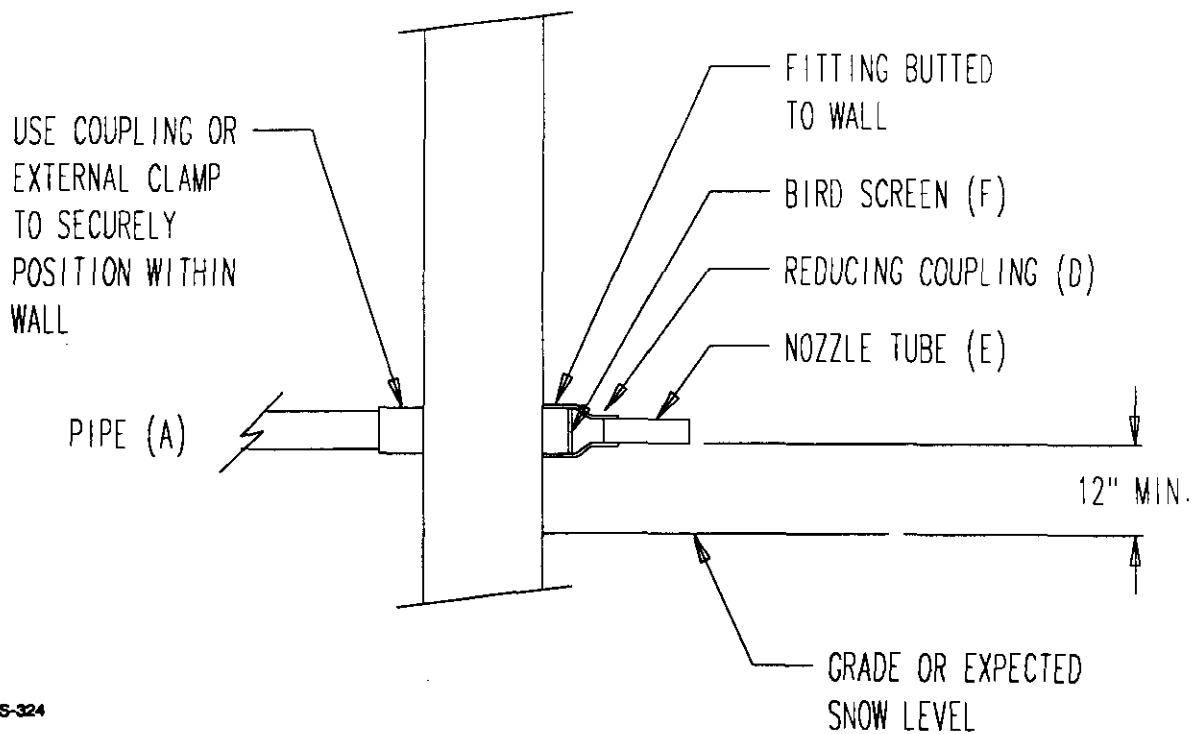

SECTION 14 – VENTING RE-SIZING INSTRUCTIONS (REPLACEMENT FURNACE ONLY)

When an existing furnace is removed from a venting system serving other appliances, the venting system is likely to be too large to properly vent the remaining attached appliances.

The following steps shall be followed with each of the appliances remaining connected to the common venting system, placed in operation one at a time while the other appliances remaining connected to the common venting system are not in operation.

1. Seal any unused openings in the venting system.
2. Inspect the venting system for proper size and horizontal pitch, as required in the National Fuel Gas Code, ANSI Z223.1 or the CAN/CGA B149 Installation Codes and these instruction. Determine that there is no blockage or restriction, leakage, corrosion and other deficiencies which could cause an unsafe condition.

3. In so far as is practical, close all building doors and windows and all doors between the space in which the appliances connected to the venting system are located and other spaces of the building. Turn on clothes dryers and any appliance not connected to the venting system. Turn on any exhaust fans, such as range hoods and bathroom exhausts so they will operate at maximum speed. Do not operate a summer exhaust fan. Close fireplace dampers.
4. Follow the lighting instructions. Place the appliance being inspected in operation. Adjust thermostat so appliance will operate continuously.
5. Test for draft hood equipped appliance spillage at draft hood relief opening after 5 minutes of main burner operation. Use the flame of a match or candle.
6. After it has been determined that each appliance remaining connected to the venting system properly vents when tested as outlined above, return doors, windows, exhaust fans, fireplace dampers and any other gas-burning appliance to their previous conditions of use.
7. If improper venting is observed during any of the above tests, the venting system must be corrected.

VENTING TROUBLESHOOTING PROCEDURES

Symtoms	Possible Causes	How to Check and/or Correct
Downdrafting through the furnace	Negative pressure within the structure caused by exhaust fan of device	Check for downdraft in vent where vent connects to unit with flame from a candle or a match.
	Location of vent terminal	Verify that vent termination is positioned with the recommended specificaitons stated in this manual.
	Incorrect or absent vent terminal	Verify that the vent terminal is designed for and is compatible with the venting system.
Condensation in venting system	Oversized venting system	Look for condensation in or around vent pipe joints or around flue connections at furnace. To correct this condition, design the venting system in accordance with the National Fuel Gas Code ANSI-Z223.1-latest edition and addenda Z223.1a-latest edition.
	Uninsulated vent installed in an unconditioned space	Check for condensation in or around vent pipe joints. Also check around the flue connecting areas on the unit. Inulate the vent in unconditioned space to prevent the above condition.
	Running vent as a liner up an existing chimney without capping off the chimney	Check to make sure the space between the vent, and the inside of the chimney has been sealed. With this space being open, it may allow too much cold air in and around the vent pipe allowing the flue products to condense causing condensation back at the unit.

FIGURE 11

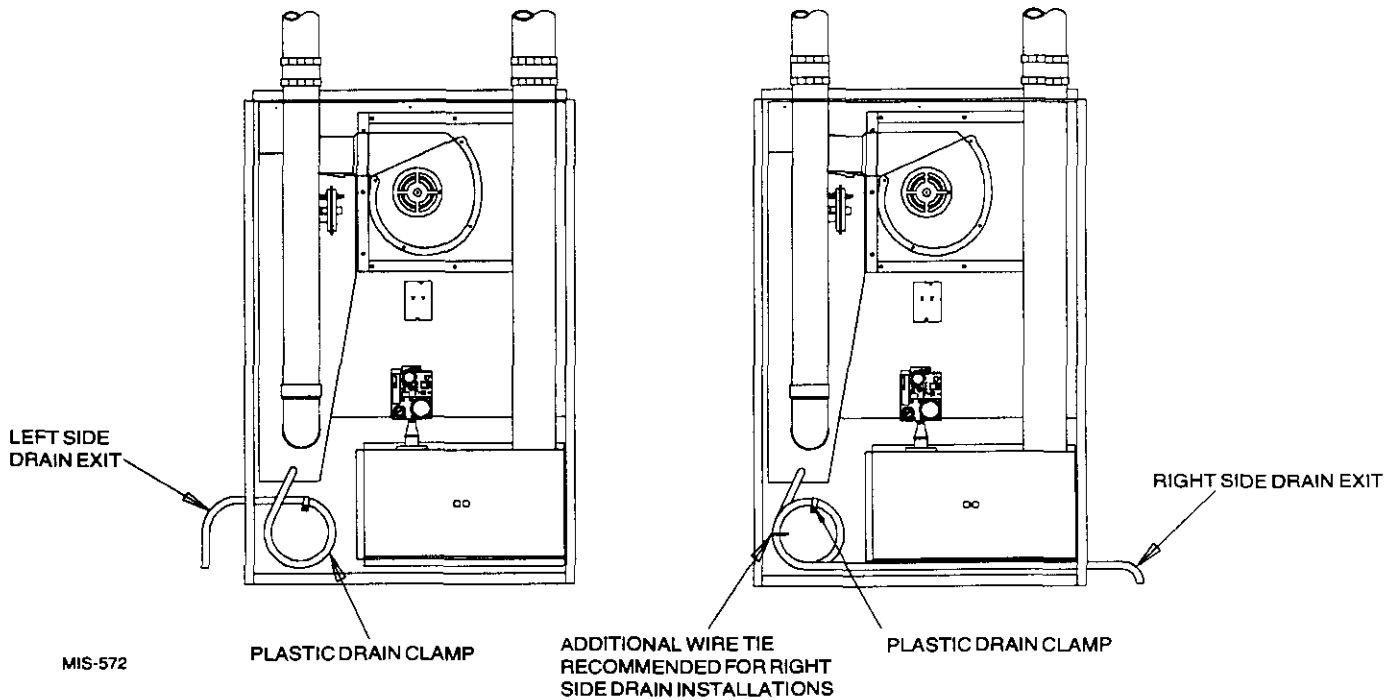

SECTION 15 – CONDENSATE DRAIN

The drain tubing that is provided with this unit is for the purpose of removing condensate from the furnace. A condensate trap is required for operation and is easily obtained when installed as shown in Figure 11. The drain can exit either the left or right side as shown. The drain line should slope "downhill" to the drain after exiting the furnace cabinet. Excessively long runs may cause condensate to back up into furnace causing cycling of the pressure switch. If this occurs, a condensate pump designed for condensing furnaces can be installed adjacent to the furnace.

 CAUTION
<p>Do not run drain to an area where temperature may drop below freezing point 32°F. Freezing of condensate could result in property damage or furnace malfunction.</p>

 CAUTION
<p>Do not connect drain tube into a drainage system that may become pressurized. Terminate furnace drain tubing into a drainage system that has some type of relief opening to prevent airlocking of furnace drain system.</p>

SECTION 16 – CONDENSATE PUMP AND NEUTRALIZER

If no floor drain is available, a condensate pump or sump pump must be used for pumping condensate to the nearest drain. A condensate neutralizer cartridge may be required depending on the type of pump and/or local codes. If a condensate pump is used or if local codes require, install a condensate neutralizer cartridge in the drain line as it exits the furnace.

Neutralizer part no. 8620-031 can be ordered separately as an option. It has a barbed fitting on both ends sized for 3/8" I.D. tubing. It can be installed either vertically or horizontally and should be located somewhere in drain line *after* it exits the furnace and *ahead* of condensate pump (if used) or drainage system.

SECTION 17 – GAS SUPPLY AND PIPING

GENERAL RECOMMENDATIONS

1. Be sure the gas line complies with the local codes and ordinances, or in their absence with National Fuel Gas Code, ANSI Z223.1-latest edition.
2. The gas line can be piped to the gas valve from either the left or right side of the furnace through the knockout opening provided. See Figure 12 for typical installation.
3. A sediment trap or drip leg must be installed in the supply line to the furnace.

4. A ground joint union shall be installed in the gas line adjacent to the upstream side from the gas valve and downstream from the manual main shutoff valve.
5. A 1/8" N.P.T. plugged tapping accessible for test gauge connection shall be installed immediately upstream of the gas supply connection to the furnace for the purpose of determining the supply gas pressure.
6. A manual shutoff valve shall be installed in the supply gas line external to the furnace when required by local code.
7. Use steel or wrought iron pipe and fittings.
8. **Do not** thread pipe too far. Valve distortion or malfunction may result from excess pipe within the control. See Table 6. Use pipe joint compound resistant to the action of liquefied petroleum gases on male threads only. **Do not** use Teflon tape.
9. Refer to Tables 7 and 8 for gas pipe sizes for both natural and propane gas. If more than one appliance is supplied from a single line size, capacity must equal or exceed the combined input to all appliances, and the branch lines feeding the individual appliance properly sized for each input.

TABLE 6
LENGTH OF STANDARD PIPE THREADS (INCHES)

Pipe Size	Effective Length of Thread	Overall Length of Thread
1/2	1/2	3/4
3/4	1/2 - 9/16	13/16
1	9/16	1

TABLE 7
GAS PIPE SIZES / CAPACITY
NATURAL GAS

Length of Pipe Ft.	Capacity Btu Per Hour Input		
	Pipe Size		
	1/2"	3/4"	1"
20'	92,000	190,000	350,000
40'	63,000	130,000	245,000
60'	50,000	105,000	195,000

FIGURE 12
TYPICAL GAS PIPING

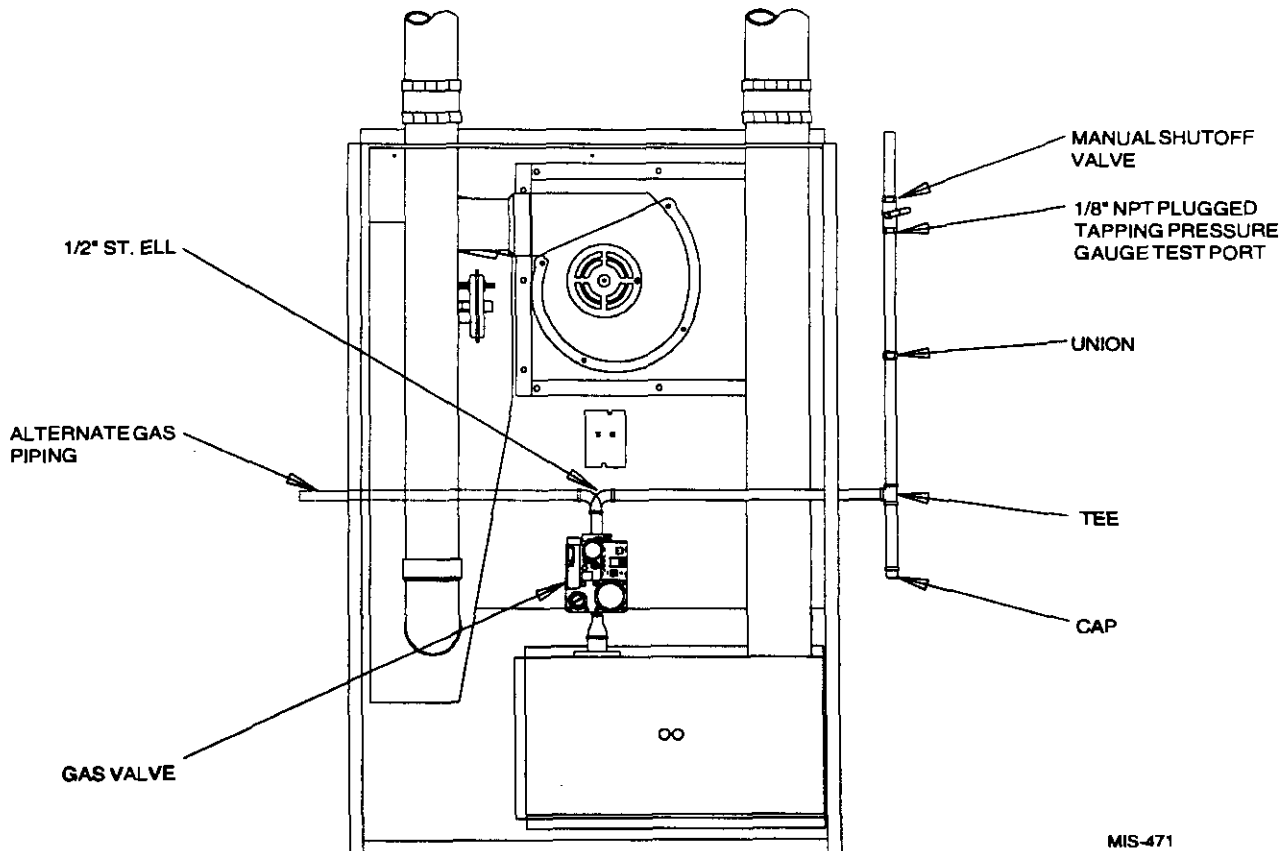

MIS-471

**TABLE 8
GAS TUBING AND PIPE SIZES
Propane Gas**

Length In Feet	Capacity -- BTU Per Hour Input			
	Copper Tubing (1)		Iron Pipe	
	1/2" (2)	3/4" (2)	1/2"	3/4"
20'	62,000	216,000	189,000	393,000
40'	41,000	145,000	129,000	267,000
60'	35,000	121,000	103,000	217,000

(1) Copper tubing for gas supply must comply with limitation in Nation Fuel Gas Code, reference "2.6.3 Metallic Tubing".

(2) Outside diameter

CHECKING THE GAS PIPING

Before turning gas under pressure into piping all openings from which gas can escape should be closed. Immediately after turning on gas, the system should be checked for leaks. This can be done by watching the 1/2 cubic foot test dial and allowing 5 minutes to show any movement, and by soaping each pipe connection and watching for bubbles. If a leak is found, make the necessary repairs immediately and repeat the above test. The furnace must be isolated from the gas supply piping system by closing the manual shutoff valve on the combination gas control valve during pressure testing of the gas supply piping system at pressures up to 1/2 psig. The furnace must be disconnected from supply piping and supply piping capped during any pressure testing of supply piping system at test pressure in excess of 1/2 psig.

Defective pipes or fittings should be replaced and not repaired. Never use a flame or fire in any form to locate gas leaks. Use soap solution.

After the piping and meter have been checked completely, purge the system of air. **Do not** bleed the air inside the furnace. Be sure to relight all the gas pilots on other appliances that may have been extinguished because of interrupted gas supply.

SECTION 18 – CHECKING GAS INPUT

NATURAL GAS

The following is a procedure in which to measure gas input:

1. Turn off all gas appliances other than the furnace.
2. From local gas supplier, obtain the average heating value in BTU/CU FT of gas supplied to the installation site.
3. Light furnace following the lighting and operating instructions label.

4. With a stop watch, measure the amount of time, in seconds, it takes to consume two (2) cubic feet of gas.
5. Use the following formula to calculate the gas input of the furnace.

$$\text{Gas input rating in BTU/HR} = \frac{\text{BTU/CU FT} \times 7200}{\text{Time in seconds for two cubic feet of gas flow}}$$

Example: Assume a time of 60 seconds for two cubic feet has been determined with a heating value of 1,000 BTU/CU FT

$$\text{Gas input rating} = \frac{1000 \times 7200}{60}$$

$$\text{Gas input rating} = 120,000 \text{ BTU/HR}$$

6. If the input rate is not within two percent of the rated input, it may be achieved by adjusting the manifold pressure. If the specified input cannot be obtained, the furnace must be re-orificed.

CAUTION

For operation at elevations above 2,000 feet, the installer must comply with the "Standard Orifice Size and High Altitude Derate" specifications in Section 20.

PROPANE GAS

The pressure regulator on the storage tank must be adjusted to maintain a 11.0" - 13.0" W.C. line supply pressure to the furnace, and the manifold pressure set at 10.0" W.C. on the exit side of the furnace gas valve. This pressure will result in correct input when the burners are orificed properly (based on 2500 Btu/cu. ft. heat content for propane gas).

WARNING

These furnaces must be equipped and operated with the correct orifice sizes and manifold pressures as specified in Sections 19 and 20. Failure to do so could result in property damage, bodily injury or death.

SECTION 19 – GAS PRESSURE SPECIFICATIONS

This furnace is equipped with fixed orifices for rated input with gas pressures listed in Table 9.

TABLE 9

Type	Supply		Manifold
	Minimum	Maximum	
Natural @ 1,000 Btu/CuFt	4.5" WC	11.0" WC	3.5" WC
Propane @ 2,550 Btu/CuFt	11.0" WC	13.0" WC	10.0" WC

The supply pressure may be measured by attaching a water column gauge to a pressure tap adjacent to and upstream from the gas valve. The manifold pressure may be measured by removing the small pipe plug located in the top of the main burner manifold, and inserting a pressure tap. Attach water column gauge to tap and ignite main burner. Small variations in the gas pressure may be made, not to exceed $\pm .03$ " WC, to achieve rated input conditions based on local gas supply Btu conditions for natural gas. See Section 18. This may be achieved by turning the gas valve regulator adjusting screw clockwise to increase pressure or counterclockwise to decrease pressure. Major changes in flow rate must be made by changing the size of the main burner orifices. See Section 20.

UNDERFIRE CONDITIONS

Underfire conditions (not setting up furnace installation for full input operation) can also cause condensation and corrosion problems. Natural gas models are to be operated at 3.5" W.C. manifold pressure with standard factory supplied orifice sizes. Models converted to propane gas are to be operated at 10.0" W.C. using the designated orifices from the approved propane conversion kit based on 2500 Btu/cu.ft..

It is **not acceptable** to either reduce manifold pressure or to reduce orifice size to compensate for oversized equipment. It is **mandatory** that manifold pressure be checked at time of installation/start up of the furnace. Adjustments, if necessary, must be made to achieve correct manifold pressure as stated above and also on the rating plate on the furnace.

WARNING

Before changing orifices, turn off electrical power and gas. Failure to do so could result in property damage, bodily injury or death.

SECTION 20 – STANDARD ORIFICE SIZING AND HIGH ALTITUDE DERATE

Ratings of gas utilization equipment are based on sea level operation and need not be changed for operation at elevations up to 2,000 feet. For operation at elevations above 2,000 feet and, in the absence of specific recommendations from the local authority having jurisdiction, equipment ratings shall be reduced at the rate of 4 percent for each 1,000 feet above sea level before selecting appropriately sized equipment. [Reference National Fuel Gas Code ANSI Z223.1 (NFPA 54), latest edition.]

These furnaces are shipped with fixed gas orifices for use with natural gas and sized for 1000 Btu/cubic feet of gas. Make sure actual furnace gas input does not exceed furnace rating plate input. You may need to change orifices to get correct gas input. Whether you do or not depends on furnace input, your gas heat value at standard conditions and elevation. Consult your local gas supplier for gas heat value and any special derating requirements. Table 10 gives normal orifice specifications based upon standard conditions as shown. See Table 11 for decimal equivalent for all orifice sizes.

For propane (LP) gas operation, the furnace must be converted using authorized propane kit sold separately.

TABLE 10
EQUIVALENT ORIFICE SIZES AT HIGH ALTITUDES
(INCLUDES 4% INPUT REDUCTION FOR EACH 1,000 FEET)

Model DCL065

Orifice Size Chart

Fuel Gas Type	Gas Heat Value Btu/CuFt *	0 to 2000 Feet	2001 to 3000 Feet	3001 to 4000 Feet	4001 to 5000 Feet	5001 to 6000 Feet	6001 to 7000 Feet	7001 to 8000 Feet	8001 to 9000 Feet	9001 to 10,000 Feet
Natural	800 - 849	3.00mm	#32	2.90mm	#34	2.80mm	2.75mm	#36	#37	#38
	850 - 899	#32	#34	2.80mm	2.75mm	#36	#37	2.60mm	#38	2.50mm
	900 - 949	#33	#35	2.75mm	#36	#37	2.60mm	#38	2.50mm	2.45mm
	950 - 999	#35	2.70mm	#37	2.60mm	#38	#39	#40	#41	#42
	1000 - 1049**	#36	2.60mm	#38	#39	2.50mm	2.45mm	2.40mm	2.35mm	2.30mm
	1050 - 1100	#37	#39	#40	#40	#41	#42	2.35mm	2.30mm	2.25mm
Propane (LP)	2500***	1.65mm	1/16"	1.55mm	1.55mm	#53	1.50mm	1.45mm	1.45mm	1.40mm

Model DCL080

Orifice Size Chart

Fuel Gas Type	Gas Heat Value Btu/CuFt *	0 to 2000 Feet	2001 to 3000 Feet	3001 to 4000 Feet	4001 to 5000 Feet	5001 to 6000 Feet	6001 to 7000 Feet	7001 to 8000 Feet	8001 to 9000 Feet	9001 to 10,000 Feet
Natural	800 - 849	2.75mm	#37	2.60mm	#38	#39	2.50mm	2.45mm	2.40mm	2.35mm
	850 - 899	#37	#39	#40	2.45mm	2.40mm	#42	2.35mm	2.30mm	2.25mm
	900 - 949	2.60mm	2.50mm	2.45mm	#41	2.40mm	2.35mm	2.30mm	#43	2.20mm
	950 - 999	#39	#41	2.40mm	#42	2.30mm	2.30mm	2.25mm	2.20mm	2.15mm
	1000 - 1049**	2.45mm	#42	2.35mm	2.30mm	#43	2.20mm	#44	2.10mm	#45
	1050 - 1100	2.40mm	2.30mm	#43	2.25mm	2.20mm	#44	2.10mm	2.10mm	2.05mm
Propane (LP)	2500***	#53	1.45mm	1.45mm	1.40mm	1.40mm	1.35mm	1.35mm	1.30mm	1.30mm

Model DCL095

Orifice Size Chart

Fuel Gas Type	Gas Heat Value Btu/CuFt *	0 to 2000 Feet	2001 to 3000 Feet	3001 to 4000 Feet	4001 to 5000 Feet	5001 to 6000 Feet	6001 to 7000 Feet	7001 to 8000 Feet	8001 to 9000 Feet	9001 to 10,000 Feet
Natural	800 - 849	3.00mm	#32	2.90mm	#34	2.80mm	2.75mm	#36	#37	#38
	850 - 899	2.90mm	2.80mm	7/64"	2.75mm	2.70mm	#37	#38	#39	#40
	900 - 949	#34	2.75mm	2.70mm	#37	2.60mm	#38	#39	#40	#41
	950 - 999	2.75mm	#37	2.60mm	#38	#39	2.50mm	2.45mm	2.40mm	2.35mm
	1000 - 1049**	2.70mm	2.60mm	#38	#39	#40	#41	2.40mm	2.35mm	2.30mm
	1050 - 1100	2.60mm	2.50mm	2.45mm	#41	2.40mm	2.35mm	2.30mm	#43	2.20mm
Propane (LP)	2500***	1.65mm	1/16"	1.55mm	1.55mm	#53	1.50mm	1.45mm	1.45mm	1.40mm

* At standard conditions: Sea level pressure and 60°F temperature

** Standard factory supplied orifice size

*** Btu/cu.ft. at 60°F

TABLE 10
EQUIVALENT ORIFICE SIZES AT HIGH ALTITUDES
(INCLUDES 4% INPUT REDUCTION FOR EACH 1,000 FEET)
(continued)

Model DCL110

Orifice Size Chart

Fuel Gas Type	Gas Heat Value Btu/CuFt *	0 to 2000 Feet	2001 to 3000 Feet	3001 to 4000 Feet	4001 to 5000 Feet	5001 to 6000 Feet	6001 to 7000 Feet	7001 to 8000 Feet	8001 to 9000 Feet	9001 to 10,000 Feet
Natural	800 - 849	#35	2.70mm	#37	2.60mm	#38	#39	#40	#41	#42
	850 - 899	#36	2.60mm	#38	#39	2.50mm	2.45mm	2.40mm	2.35mm	2.30mm
	900 - 949	#37	#38	2.50mm	#40	#41	2.40mm	2.35mm	2.30mm	2.25mm
	950 - 999	#38	#40	2.45mm	2.40mm	#42	2.35mm	2.30mm	2.25mm	2.20mm
	1000 - 1049**	2.50mm	2.40mm	#42	2.35mm	2.30mm	#43	2.25mm	#44	2.15mm
	1050 - 1100	2.45mm	#42	2.35mm	2.30mm	#43	2.20mm	#44	2.10mm	#45
Propane (LP)	2500 ***	#53	1.45mm	1.45mm	1.40mm	1.40mm	1.35mm	1.35mm	1.30mm	1.30mm

* At standard conditions: Sea level pressure and 60°F temperature

** Standard factory supplied orifice size

*** Btu/cu.ft. at 60°F

TABLE 11
ORIFICE DRILL SIZE DECIMAL EQUIVALENTS

Drill No. Decimal	3.50mm .1378	#29 .1360	3.40mm .1399	3.30mm .1299	#30 .1285	3.25mm .1279	3.20mm .1260	1/8" .1250	3.10mm .1221	#31 .1200
Drill No. Decimal	3.00mm .1181	#32 .1160	2.90mm .1142	#33 .1130	#34 .1110	2.80mm .1102	#35 .1100	7/64" .1094	2.75mm .1082	#36 .1065
Drill No. Decimal	2.70mm .1063	#37 .1040	2.60mm .1024	#38 .1015	#39 .0995	2.50mm .0984	#40 .0980	2.45mm .0964	#41 .0960	2.40mm .0945
Drill No. Decimal	3/32" .0938	#42 .0935	2.35mm .0925	2.30mm .0906	#43 .0890	2.25mm .0885	2.20mm .0866	#44 .0860	2.15mm .0846	2.10mm .0827
Drill No. Decimal	#45 .0820	#46 .0810	2.05mm .0807	2.00mm .0787	#47 .0785	5/64" .0781	1.95mm .0767	#48 .0760	1.90mm .0748	#49 .0730
Drill No. Decimal	1.85mm .0728	1.80mm .0709	#50 .0700	1.75mm .0688	#51 .0670	1.70mm .0669	1.65mm .0649	#52 .0635	1.60mm .0630	1/16" .0625
Drill No. Decimal	1.55mm .0610	#53 .0595	1.50mm .0590	1.45mm .0570	1.40mm .0551	#54 .0550	1.35mm .0531	#55 .0520	1.30mm .0512	1.25mm .0492

SECTION 21 – WIRING SPECIFICATIONS

WARNING

For your personal safety, turn off electric power at service entrance panel before making any electrical connections. Failure to do so could result in property damage, bodily injury or death.

*** IMPORTANT NOTICE ***

Proper polarity must be maintained. See wiring diagram on Page 37. Failure to do so will cause the gas valve to shut off at end of 9 second ignition trial time.

All electrical work must conform with local codes and ordinances, or in their absence, with the National Electrical Code, ANSI/NFPA No. 70 - latest edition.

ELECTRICAL POWER SUPPLY

Run a separate 120V, AC circuit from a separate fuse or circuit breaker in the service entrance panel with an ampacity rating as shown in Table 12. Locate a shutoff switch at the furnace. Make connections from this switch to the furnace junction box as shown in the furnace wiring diagram.

RECOMMENDED ELECTRICAL GROUNDING METHOD

When installed the furnace must be electrically grounded in accordance with local codes or in the absence of local codes with the National Electrical Code, ANSI/NFPA No. 70 - latest edition. Use #14 AWG copper wire from GREEN ground wire in the field wiring junction box to a grounded connection in the service panel or a properly driven and electrically grounded ground rod.

FIELD INSTALLED EQUIPMENT

Wiring to be done in the field between the furnace and devices not attached to the furnace, or between separate devices which are field installed and located, shall conform with the temperature limitation for Type T wire (63°F rise – 36°C) when installed in accordance with the manufacturer's instructions. Refer to wiring diagrams.

ELECTRONIC AIR CLEANER AND HUMIDIFIER ACCESSORIES

See Section 28, Accessory Wiring, for specific information on connecting the accessories.

SECTION 22 – THERMOSTAT

Install the thermostat in accordance with instructions packed with it. Locate the thermostat 4-1/3 feet from the floor on an inside wall away from drafts, warm air registers, and floor or table lamps. Refer to furnace wiring diagrams for connections.

All 24 volt wall thermostats have heat anticipators to compensate the thermostat for various system controls and allow the best possible cycle rates. Some anticipators are fixed and require no adjustment. However, the majority of wall thermostats have adjustable anticipators and do require adjustment to match the current rating of the gas valve. The nominal heat anticipator setting for these furnaces is .45A.

ISOLATING RELAY FOR ELECTRONIC THERMOSTATS

Some designs of electronic thermostats are "power stealing" and operate off of the furnace controls in such a manner as to not be compatible with the Integrated Furnace Control.

Addition of an isolation relay as shown in Figure 13 will correct this compatibility problem and sometimes is a desirable solution as an alternative to replacing the thermostat.

TABLE 12

Model	Volts / HZ / PH	Total Amps	Blower Motor		Inducer Motor		Minimum Circuit Ampacity	Minimum Time Delay Fuse OR HACR Circuit Breaker
			HP	FLA	HP	FLA		
DCL065	115-60-1	6.5	1/3	6.5	1/35	1.4	15	15
DCL080	115-60-1	10.5	1/4	10.5	1/35	1.4	15	20
DCL095	115-60-1	12.5	3/4	12.5	1/35	1.4	16	20
DCL110	115-60-1	11.0	3/4	11.0	1/35	1.4	15	20

FIGURE 13

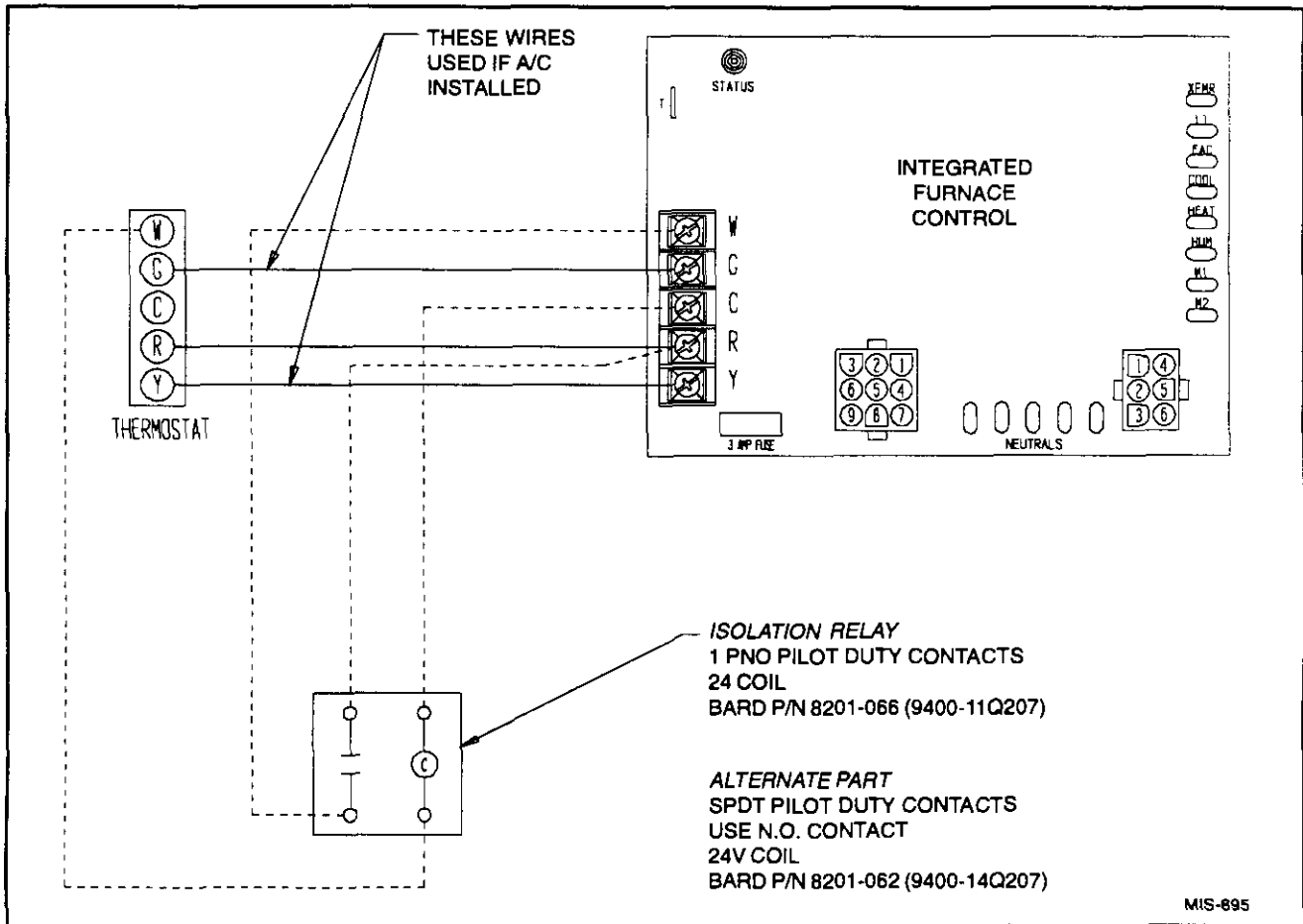

FURNACE TWINNING OPTIONS

Shown in Figures 14, 15 and 16 are furnace twinning options using three different types of thermostat hookups. Twinning of furnaces (two furnaces tied into a large common duct system installation is also discussed in Section 27.

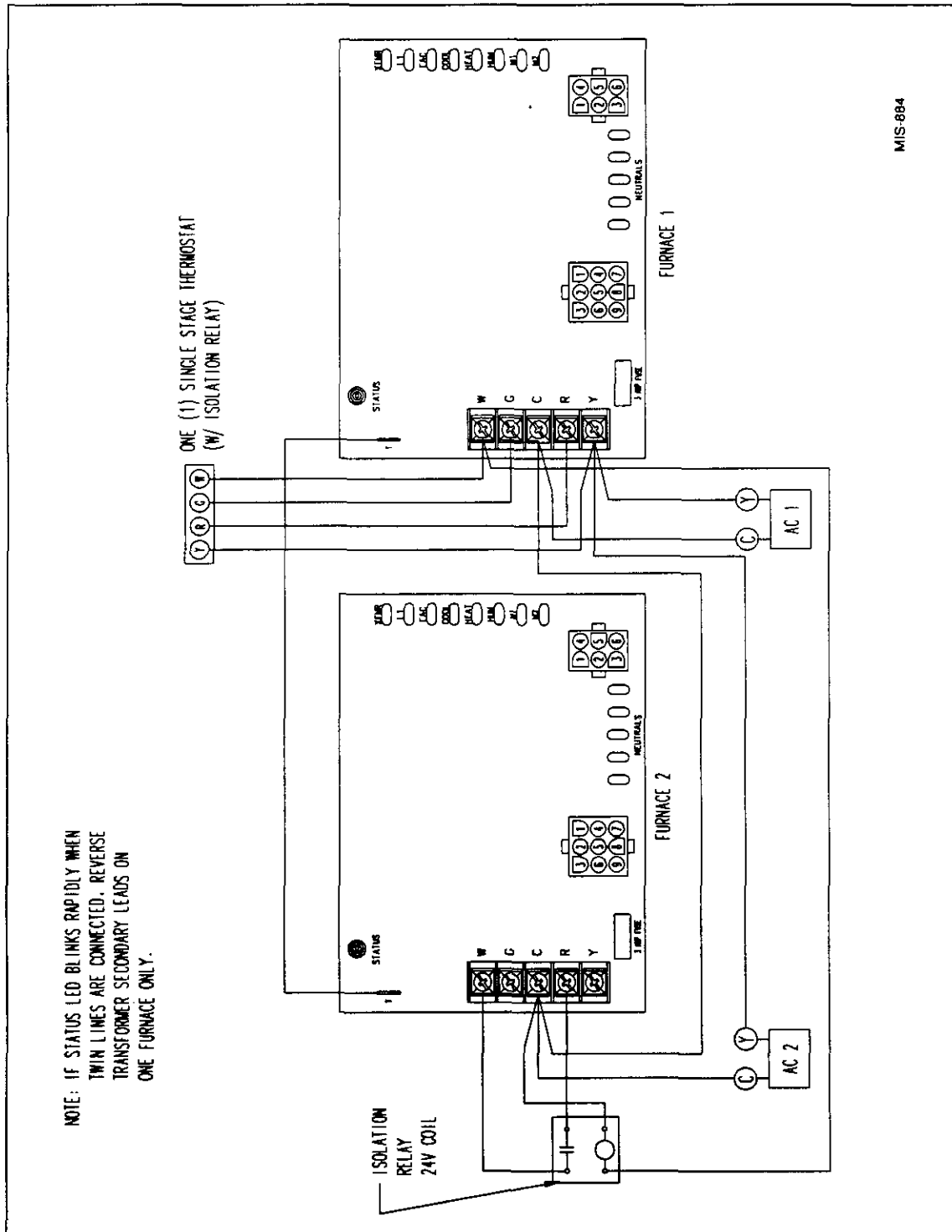
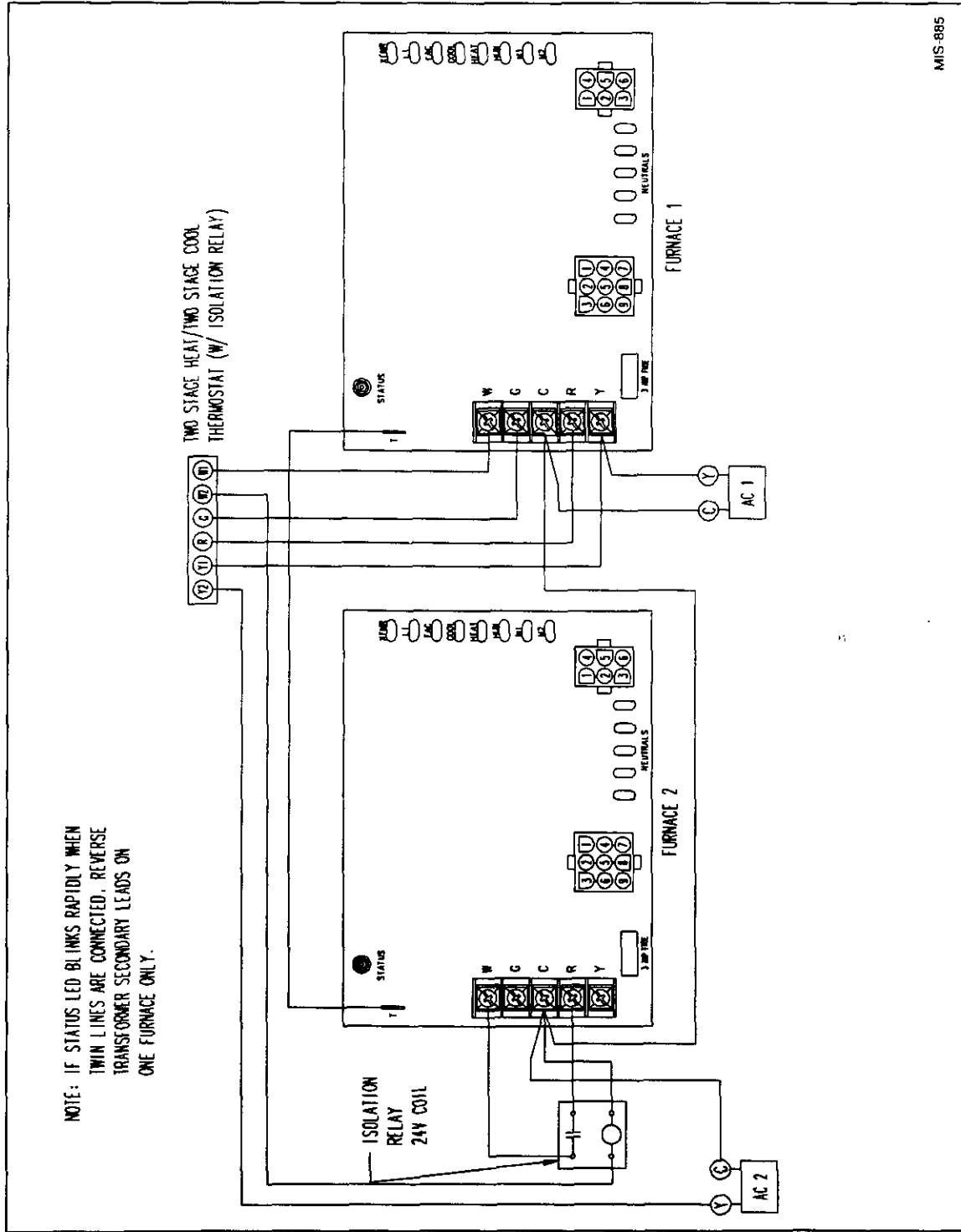
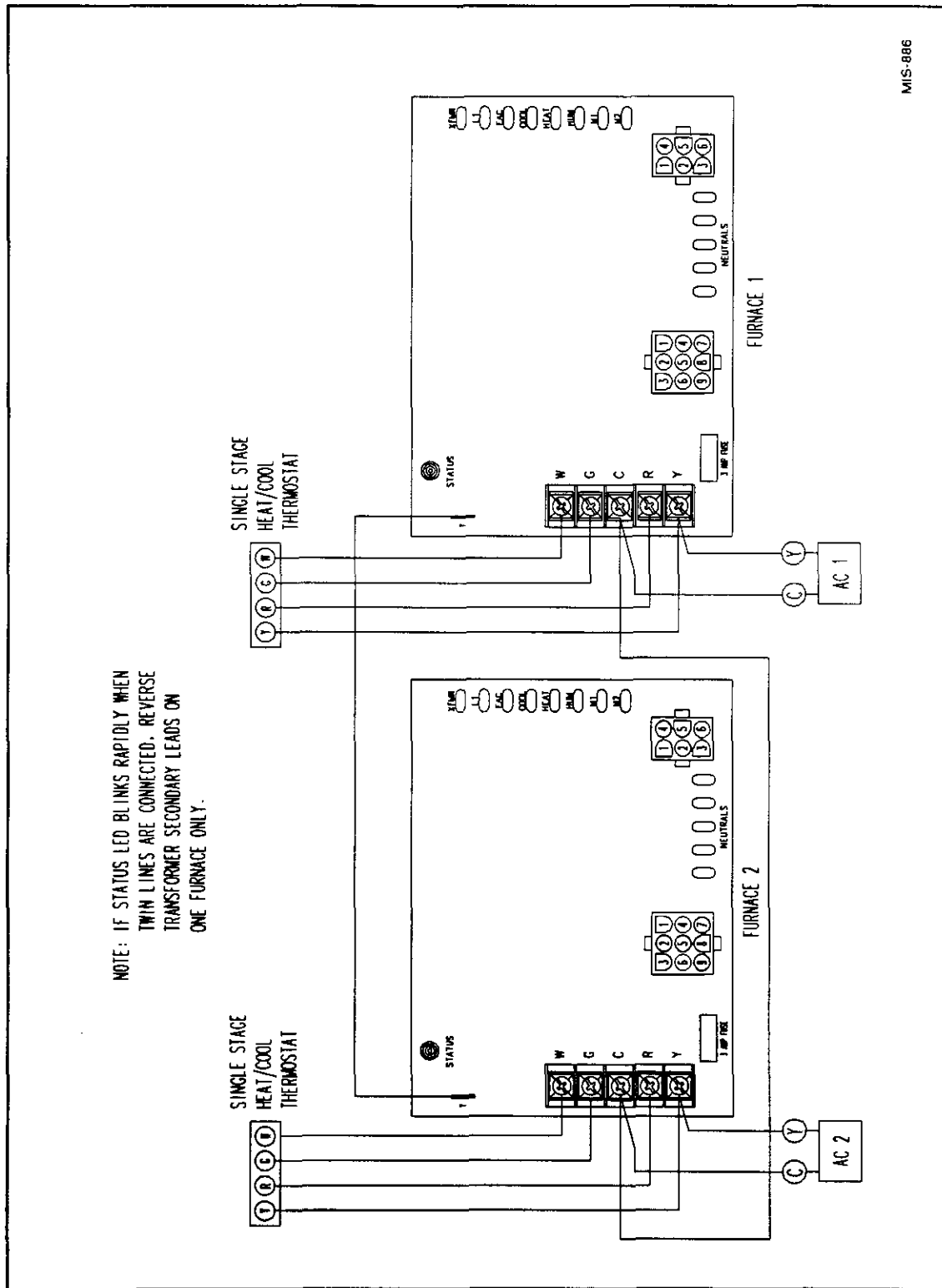

FIGURE 14 – TWINNING DIAGRAM – ONE THERMOSTAT WITH TWO FURNACES AND TWO AIR CONDITIONERS

FIGURE 15 -- TWINNING DIAGRAM -- TWO STAGE HEAT/COOL THERMOSTAT WITH TWO FURNACES AND TWO AIR CONDITIONERS





NOTE: IF STATUS LED BLINKS RAPIDLY WHEN TWIN LINES ARE CONNECTED, REVERSE TRANSFORMER SECONDARY LEADS ON ONE FURNACE ONLY.

MIS-886

FIGURE 16 - TWINNING DIAGRAM - SEPARATE THERMOSTAT FOR EACH FURNACE AND AIR CONDITIONER

SECTION 23 – BLOWER OPERATION

All models are three or four speed direct drive and are equipped with a heating/cooling blower relay. When matched with the appropriate wall thermostat offers manual blower operation from the wall thermostat for air circulation. See Sequence of Operation for specific details on blower operation.

BLOWER SPEED ADJUSTMENT

WARNING

When servicing or changing blower motor speeds, always turn off electrical power supply to the furnace to prevent possibility of electrical shock hazard.

In the event that more air or less air is desired for either the heating or cooling mode, blower speeds may be adjusted by connecting the desired speed tap to the heating or cooling connection on the Integrated Furnace Control. See wiring diagram on Page 37 or on the furnace door. M1 and M2 are dummy terminals for unused speed taps. All models are

factory wired on medium (for 3 speed) and med-low (for 4 speed) for heating and high speed for cooling. See Table 13 for recommended motor speeds for various size add-on air conditioning systems. Consult wiring diagram for additional information.

Some installations may require the same speed for heating and cooling. If so, remove both leads connected to the HEAT and COOL terminals on Integrated Furnace Control, and using a jumper wire and 1/4" terminal multiplier, connect HEAT and COOL together and connect the desired motor speed lead to the open terminal on multiplier.

NOTE: There are only two dummy terminals, M1 and M2, for unused motor speeds. The lead not connected to the control must be taped off.

*** IMPORTANT NOTICE ***

After the furnace is operating with filters installed and all cabinet panels are in place, check the temperature rise through the unit to insure it is within the range specified on the furnace rating plate. If it is not, adjust blower speed until the temperature is near the center of the specified range.

TABLE 13
AIRFLOW CAPACITIES AND MOTOR SPEED INFORMATION

Model	Blower Whl. Size D" x W"	Motor HP	Motor Speed	Speed Range	CFM			Inches H ₂ O	Maximum Tons Cooling	Temperature Rise Range Degrees F	Rated Heating * CFM
					.20	.30	.50				
DCL065	10 x 8	1/3	3	Low	840	815	710	2	35 - 65	1,100	
				Medium	1080	1045	975				
				High	1310	1260	1150				
DCL080	10 x 10	1/2	4	Low	1125	1110	1025	2-1/2	30 - 60	1,212	
				Med-Low	1350	1315	1200				
				Med-High	1550	1470	1350				
				High	1755	1670	1500				
DCH095	11 x 10	3/4	4	Low	1305	1281	1220	3	35 - 65	1,600	
				Med-Low	1470	1435	1360				
				Med-High	1705	1660	1600				
				High	2000	1950	1810				
DCH110	Double 10 x 6	3/4	4	Low	1335	1330	1270	3	40 - 70	1,670	
				Med-Low	1535	1520	1435				
				Med-High	1740	1685	1560				
				High	2005	1950	1800				

* Recommended design airflow for best operation and efficiency of the furnace.

SECTION 24 – AIR FILTERS

All models are shipped with washable air filters. See Table 14 for sizes and Figure 17 for removal and replacement information.

TABLE 14
FILTER SIZE FOR GAS FURNACE

Model	Quantity and Size
DCL065	1 -- 9-1/2 x 20 x 1
DCL080 DCL095	1 -- 10 x 20 x 1 and 1 -- 13 x 20 x 1
DCL110	2 -- 13 x 20 x 1

FILTER LOCATION – REMOVAL AND REPLACEMENT PROCEDURES

The air filter is located at the back of the furnace in the comfort air blower compartment. Each furnace is equipped with one filter. To remove the filter from the furnace, first remove the rear blower compartment door by turning door latches with a screwdriver or a dime.

Grasp the filter by the frame and pull filter straight back and out.

These filters are a washable high velocity type filter which may be washed over and over. ***Do not replace with a fiberglass disposable filter of any size.***

To replace filter, reverse the procedure.

NOTE: *The filter rests on an angle that is attached to the blower partition. Make sure the filter is installed properly. (See Figure 17.)*

FIGURE 16

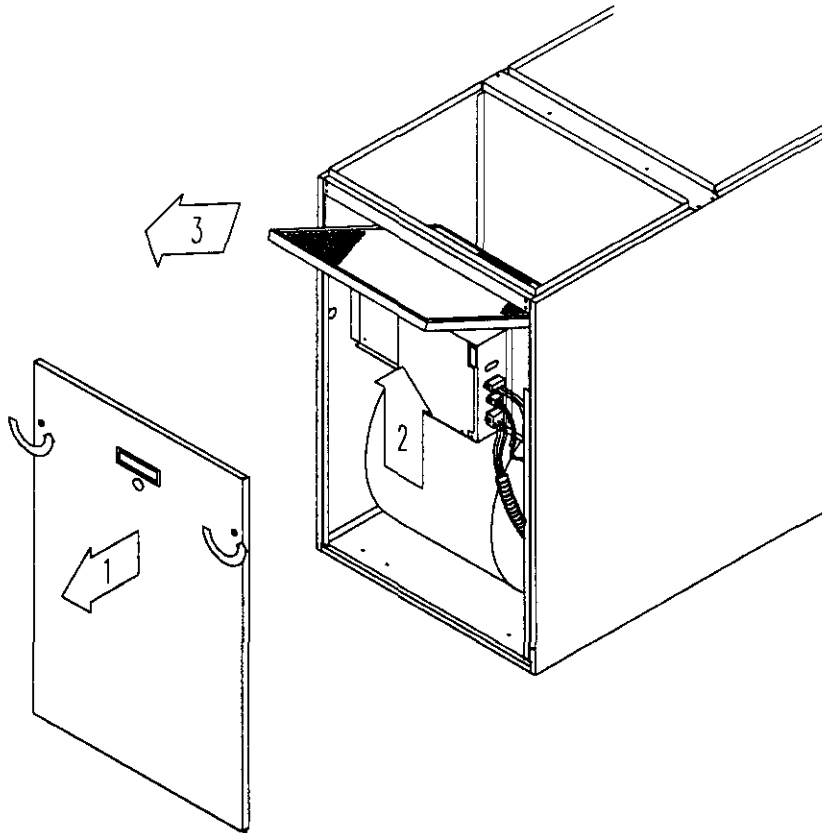

MIS-570

SECTION 25 – LIGHTING AND OPERATION INSTRUCTIONS

FOR YOUR SAFETY READ BEFORE OPERATING

WARNING: If you do not follow these instructions exactly, a fire or explosion may result causing property damage, personal injury or loss of life.

- A. This appliance does not have a pilot. It is equipped with an ignition device which automatically lights the burner. Do NOT try to light the burner by hand.
- B. BEFORE OPERATING smell all around the appliance area for gas. Be sure to smell next to the floor because some gas is heavier than air and will settle on the floor.

WHAT TO DO IF YOU SMELL GAS

- * Do not try to light any appliance.
- * Do not touch any electric switch; do not use any phone in your building.
- * Immediately call your supplier from a neighbor's phone. Follow the gas supplier's instructions.

*If you cannot reach your gas supplier; call the fire department.

- C. Use only your hand to push in or move the gas control lever. Never use tools. If the lever will not push in or turn by hand, don't try to repair it, call a qualified service technician. Force or attempted repair may result in a fire or explosion.
- D. Do not use this appliance if any part has been under water. Immediately call a qualified service technician to inspect the appliance and to replace any part of the control system and any gas control which has been under water.

OPERATING INSTRUCTIONS

1. STOP! Read the safety information above on this label.
2. Set the thermostat to lowest setting.
3. Turn off all electric power to the appliance.
4. This appliance is equipped with an ignition device which automatically lights the burner. Do NOT try to light the burner by hand.

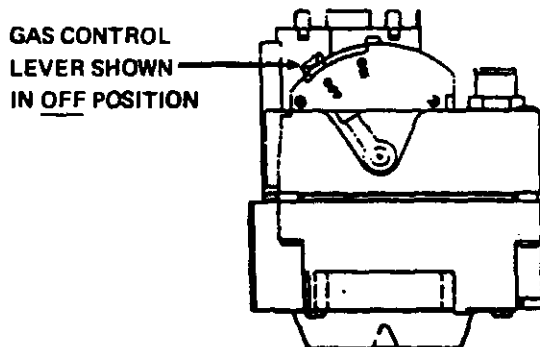

5. Remove control access panel.
6. Push in gas control slightly and move to "OFF" position.
NOTE: Knob cannot be moved to "OFF" unless lever is pushed in slightly. Do not force.
7. Wait five (5) minutes to clear out any gas. Then smell for gas, including near the floor. If you smell gas, STOP! Follow "B" in the safety information above on this label. If you don't smell gas, go to the next step.
8. Move gas control lever to "ON" position.
9. Replace control access panel.
10. Turn on all electric power to the appliance.
11. Set thermostat to desired setting.
12. If the appliance will not operate, follow the instructions "To Turn Off Gas To Appliance" and call your service technician or gas supplier.

TO TURN OFF GAS TO APPLIANCE

1. Set the thermostat to lowest setting.
2. Turn off all electric power to the appliance if service is to be performed.
3. Remove control access panel.
4. Push in gas control lever slightly and move to "OFF". Do not force.
5. Replace control access panel.

7861-423

SECTION 26 – SEQUENCE OF OPERATION

The operation sequences shown below describes normal operation. See Section 27 for detailed explanation of Integrated Furnace Control (IFC), and explanations of abnormal occurrences.

1. BASIC FURNACE – HEATING CYCLE

This furnace is operated by an Integrated Furnace Control (IFC) which controls all functions of the furnace.

On a call for heat from the thermostat, the IFC first checks the pressure switch to verify contacts are open, then turns on the inducer motor. The pressure switch then closes signaling the IFC to proceed with ignition function.

There is a 36 second ignitor heat up period, then the gas valve opens introducing main burner gas to be ignited by the hot surface ignitor. The ignitor turns off 6 seconds after gas valve opens, and the flame sensor must prove ignition and carryover across all burners within 9 seconds after the gas valve opens.

There is a 60 second delay after main burner is on until the comfort air blower starts on heating speed. After the thermostat is satisfied, the burners will go off as gas valve closes. The inducer will continue to run for 30 seconds, and the comfort air blower will continue to run for 120 seconds standard. Can be increased to 180 seconds. See Section 27.

*** IMPORTANT NOTICE ***

The furnace cannot be recycled from the wall thermostat during the heating blower off delay period.

A new call for heat can be initiated during this period but the system will "wait" until the blower off delay times out.

2. ACCESSORIES (OPTIONAL, FILED INSTALLED)

The furnace and IFC are designed to accommodate both electronic air cleaner and humidifier. The electronic air cleaner circuit is powered any time the comfort air blower runs on either heating or cooling speed. The humidifier circuit is powered any time the inducer motor is operating. See Section 28 for more information.

3. COOLING CYCLE OPERATION

If optional add on air conditioning system is installed, the comfort air blower starts on cooling speed immediately on call for cool; will run continuously during the call for cool; and will stop 60 seconds after the thermostat is satisfied.

4. MANUAL FAN (CONTINUOUS AIRFLOW) OPERATION

If wall thermostat is set to MANUAL (ON) position to operate comfort air blower continuously to provide air circulation throughout the building, the blower will operate on the *heating* speed rather than the cooling as is typical with most systems. This permits the air to circulate as desired but helps keep the operating noise level down as well as conserving energy.

When a call for heat occurs, the blower will continue to run during the ignitor heat up period, but shut off for 60 seconds after gas valve opens and burners ignite to accelerate the heat exchanger heat up process. The blower then restarts and runs continuously until the next burner cycle as described above.

During a call for cooling, the blower automatically shifts up to cooling speed, and remains there until 60 seconds after thermostat is satisfied then drops back to heating speed.

SECTION 27 – INTEGRATED FURNACE CONTROL (IFC)

The Integrated Furnace Control (IFC) controls all aspects of the furnace operation. Shown in Table 15 are the IFC specifications covering Ignition Sequence Control, Comfort Fan Control, Accessory Control and Diagnostics.

Specific information on TWINNING of furnaces (2 furnaces tied into a large common duct system installation) is detailed in Section 22, Thermostats. This twinning feature assures simultaneous starting and stopping of the comfort air blowers in each furnace which is essential to prevent air short circuiting through one of the furnaces if the blower is only running in the other furnace.

DIAGNOSTICS are provided through a light emitting diode (LED) mounted on the IFC. A clear sight glass is located in the vestibule door lining up with the LED. Therefore, the LED can be observed without removing any furnace panel to determine operating status or problem condition that might be present.

TABLE 15

IGNITION SEQUENCE CONTROL

Ignition Source	115 VAC HSI (Norton 201)
Flame Sensing	Remote
Timings	
- Prepurge	0 seconds
- Postpurge	30 seconds (0 if cycle terminated before valve "on")
- Inter-trial purge	30 seconds
- Pressure switch proving period	60 seconds
- Trials for ignition	3 per ignition sequence
- 1st trial heat up	36 seconds
- 2nd and 3rd trials (if needed)	46 seconds
- Trial for ignition	9 seconds
	- Valve and ignitor on for 1st 6 seconds
	- Valve only for last 3 seconds
- Ignition sequence lockout	60 minutes (after 3 trials for ignition), auto reset
	- Can be reset during the 60 minute lockout period by opening thermostat circuit for 3 seconds or more.
- Heat blower on - delay	30 seconds (timing starts when ignitor cycles off)
- Heat blower off - delay	60 - 90 - 120 - 150 seconds selectable; factory set at 120
- Cool blower on - delay	6 seconds
- Cool blower off - delay	60 seconds
- Manual fan operations	Operates on selected heating speed and does not cycle off during ignition or burner start up sequence
- High limit control operation	Automatic reset, ignition sequence restart is delayed for 5 minutes after the limit resets for the first three trials. See Note 1.
- Flame rollout switch operation	Manual reset, ignition sequence is delayed for 5 minutes after switch is manually reset. See Note 1.

Note 1: After the fourth limit trip there will be a 1 hour delay before the ignition sequence will restart. After either high limit switch or flame rollout switch actuation, the inducer will operate for the 30 second postpurge and the comfort air blower will operate for the selected off delay. If on Manual Fan operation, the comfort air blower will continue to operate.

SAFETY UNITS

High Limit / Rollout	SPST in 24 volt circuit
Pressure Switch	SPST, safe start check (60 seconds proving time)

COMFORT FAN CONTROL

Heating Speed Fan

Normal Operation	
- ON delay	30 seconds fixed. Timing starts when ignitor de-energized.
	4 selectable timings - 120 seconds standard can be changed to 60, 90 or 150 seconds
Limit Operation	ON when limit is OPEN
	OFF after OFF delay when limit CLOSES
Flame Sense	ON if flame is sensed and there is no call for heat
<u>Cooling Speed Fan</u>	
- ON delay	6 seconds
- OFF delay	60 seconds
<u>Manual Fan</u>	ON continuously on HEATING speed. When call for cool, the fan switches to COOLING speed. Then when thermostat satisfied, the fan switches back to HEATING speed after COOLING OFF delay.

ACCESSORY CONTROL

Electronic Air Cleaner	ON /OFF with comfort fan
Humidifier	ON / OFF with combustion blower *
	* Atomizing type humidifier requires use of sail switch

FAULT CODES - LED SIGNAL

- Heartbeat	Standby condition (waiting for thermostat command)
- Rapid flash	Either a wrong line voltage polarity condition or twinning fault
- Steady ON	Call for heat initiated and normal operation
- 1 short flash	Ignition sequence fault
- 2 short flashes	Pressure switch normally open contacts are stuck closed
- 3 short flashes	Pressure switch did not close during the 60 second proving period (Inducer, pressure switch, tubing or vent problem)
- 1 long, 3 short flashes	Pressure switch opened during the run cycle and did not re-close during 30 second inducer postpurge period
- 4 short flashes	Safety circuit open (High limit switch or flame rollout switches)
- 5 short flashes	False flame or valve energized without a call for heat
- OFF (out)	No 115V or 24V power, or Integrated Control failure. Also check 3A fuse on IFC.

FIGURE 18

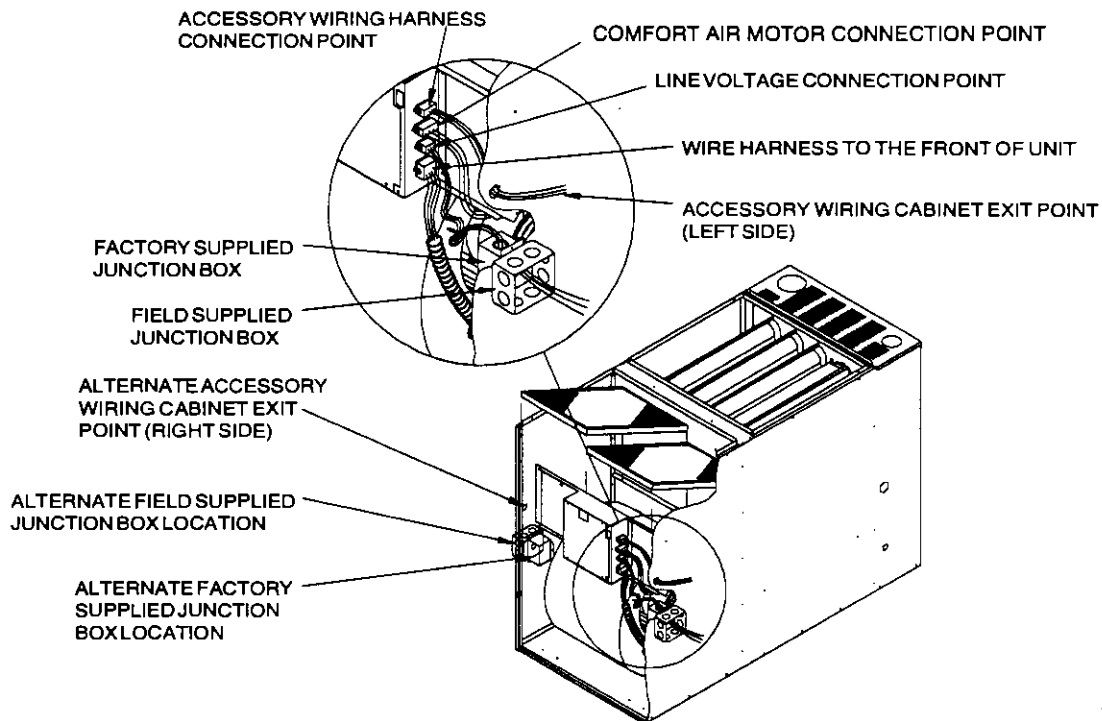

MIS-567

SECTION 28 – ACCESSORY WIRING

GENERAL INFORMATION

An optional wiring harness, part no. 8620-044, is available to simplify wiring connections for installation of an electronic air cleaner and/or a humidifier. A 115V power supply is output to these two accessory wiring terminals under the following conditions of unit operation:

115V Electronic Air Cleaner – Powered whenever the comfort air blower motor is operating on either heating or cooling speed.

115V Humidifier – Powered whenever the combustion air blower is operating.

Humidifier Notes:

1. Atomizing type humidifiers also require a sail switch to be installed in the comfort air duct system to permit humidifier operation only when comfort air fan is on. The sail switch is wired in series with the RED wire on the accessory wire harness.
2. A 24V humidifier motor or solenoid will require a 115 x 24V transformer. If not included with humidifier, it will need to be supplied separately.

ACCESSORY WIRING INSTALLATION

The 8620-044 accessory wiring harness consists of a polarized 4 pin connector with 4 color-coded wires 58 inches long. The 4 pin connector plugs into the back of control box located behind the comfort air blower access

panel. The wires are routed through a knockout in the left or right side of the furnace.

A junction box should be field supplied and installed on outside of furnace cabinet, and wiring from one or both accessories routed to this junction box for connection to the accessory wiring harness.

The BROWN and one WHITE wire are for the electronic air cleaner, and the RED and one WHITE wire are for the humidifier.

Two snap bushings are provided to protect wiring as it passes through the knockout(s) in side panels at junction box location. Two are provided in case humidifier wiring is needed on one side of furnace and air cleaner on the other side. Four (4) wire nuts are provided for connection to the accessory wiring.

WARNING

Hazard of electric shock. All unused wires must be terminated with wire nuts as they will be energized as described in General Information section preceding.

See Figure 18 for pictorial detail of wire routing. Also see Section 8, Figure 2, for additional detail to assure correct knockouts are used.

SECTION 29 – ROUTINE MAINTENANCE INSTRUCTIONS

Routine maintenance procedures are the responsibility of the user and are contained in the User's Information Manual. These are briefly outlined below.

A detailed inspection of the furnace and its vent / air intake system should be conducted annually by a qualified service agency generally prior to the heating season. See Section 30.

ROUTINE MAINTENANCE

1. **Air Filters** – Check the condition on at least a monthly basis when the furnace is in use and clean or replace whenever it is necessary. Washable filters *must* be used. *Do not replace with disposable fiberglass filters.*
2. **Lubrication Requirements** – The main blower motor and induced draft blower motor are permanently lubricated; no maintenance required.
3. **Periodic Inspection of the Vent and Air Intake** – Visual inspection of the vent and air intake for any leaking, sags, dips or defective parts. The vent and intake should also be inspected outside of the structure for any blockage in the openings. If blockage is present, the screens should be cleaned with a vacuum cleaner.
4. **Periodic Inspection of Drain Line** – The drain line on a condensing furnace should be checked monthly for blockage or freezing of drain condensate. Blockage of drain will prevent furnace operation.

SECTION 30 – SERVICING FURNACE

The following procedures should be performed by a qualified dealer serviceman.

WARNING

Label all wires prior to disconnection when servicing controls. Wiring errors can cause improper and dangerous operation. Verify proper operation after servicing. Failure to do so could cause improper furnace operation resulting in damage, injury or death.

WARNING

Use replacement parts listed in parts list. Failure to do so could cause improper furnace operation resulting in damage, injury or death.

WARNING

Follow these procedures *before* inspecting furnace.

- Turn room thermostat to its lowest or off setting.
- Turn off manual gas shutoff valve.
- Wait at least 5 minutes for furnace to cool if it was recently operating.
- Turn off furnace electrical power. Failure to do so could result in injury or death.

Perform periodic preventative maintenance once before heating season begins and once during heating season. Inspect, clean and repair as needed the following items:

CHECKING THE CIRCULATING AIR BLOWER ASSEMBLY

1. Remove blower service panel.
2. Remove air filters
3. Disconnect plug connectors from the right side of the control panel. Disconnect thermostat wires from 24 volt terminal block on control.
4. Remove four (4) screws holding control panel and bracket to side angles. Remove control panel assembly from compartment. See Figure 18.
5. Remove four (4) screws from the blower angles. Lift blower straight up and tilt back towards you as you pull up on the blower.
6. The blower is now free to be pulled from the furnace.
7. Reverse the above steps for reinstallation.

CHECKING THE HOT SURFACE IGNITOR

1. Disconnect the two (2) YELLOW leads connected to the double 3/16" quick connect terminal bushing on left side of burner box.
2. Using an ohmmeter, check the resistance of the ignitor. Cold resistance should be 45 - 250 ohms. Resistance above 250 ohms could indicate a fracture or hairline crack, and ignitor should be replaced.
3. To replace ignitor, remove burner box cover, and then disconnect the two (2) ignitor leads from the double 3/16" terminal bushing on inside of burner box.
4. Carefully remove the two (2) screws securing ignitor mounting bracket and extract ignitor through the open space to left of gas manifold vertical riser.

5. Replace ignitor by removing nut and bolt from bracket, placing new ignitor in bracket and fastening with nut and bolt.
6. Reverse above steps to install ignitor/bracket assembly back into furnace. The 1/4" tab section on top of ignitor bracket must fit into 1/8" slot of ignitor bracket mounting panel; then secure bracket with the two (2) screws.

CHECKING THE BURNERS

1. Inspect the burner assembly for any scaling, sooting or blockage of ports. If there are signs of this, the burner should be removed and cleaned with a wire brush until all soot and scale is removed and burner ports are not obstructed.

 <h1 style="margin: 0;">CAUTION</h1>
<p>Before removing burners for cleaning, the hot surface ignitor must be removed first to avoid damaging the ignitor. Failure to do so can result in breakage of the ignitor requiring its replacement.</p>

2. The gas piping to gas valve will usually require disconnection to permit valve and manifold assembly to be unfastened and moved out of the way to allow burner assembly to be extracted from furnace. The split grommet around manifold vertical riser will slide out of the slotted opening on top of burner box.
3. Remove two (2) screws on both left and right side burner brackets securing brackets to the interior support plate.
4. The burner is now free to be pulled out and examined, and cleaned as outlined in Step 1 above.
5. Reinstall all parts by reversing above steps.

 <h1 style="margin: 0;">WARNING</h1>
<p>The grommet that seals the gas manifold vertical riser to the top panel of the burner box is a critical seal. It must be reinstalled exactly as it was removed to assure proper operation of the pressure switch supervising vent/air intake piping systems. Failure to install properly could result in property damage, bodily injury, or death.</p>

CHECKING THE HEAT EXCHANGER AND FLUE GAS PASSAGEWAYS

Furnaces that are properly installed and maintained will normally not require cleaning of the heat exchangers.

The only time it should be necessary to disassemble and clean the interior of both the primary and secondary heat exchangers would be due to a sooting condition caused by abnormal combustion.

The inside of the primary heat exchanger can be examined for scale and soot using a light and a mirror on an extension handle. If soot and/or scale is evident, the heat exchanger must be cleaned as follows:

1. Remove burner assembly from inlet to heat exchanger. See "Checking The Burners" section.
2. Disconnect the 2 pin connector for inducer motor, unplug pressure switch tubing from inducer, and carefully remove the four (4) screws securing inducer housing to the flue collector box.
3. Carefully work the inducer housing and the 3 inch plastic elbow fitting connected between blower outlet and secondary heat exchanger inlet loose. Both ends of the 3 inch elbow are sealed with a high temperature silicone sealant, and by carefully working the inducer assembly up and away from the flue collector box, one or both of the silicone sealant connections will break free.
4. Now the flue collector box can be removed along with the internal flue baffles.
5. Using a small wire brush on extension handle, brush inside walls of the heat exchanger until soot and/or scale is removed. The loose scale and/or soot is easily removed using a vacuum cleaner at the bottom of the heat exchanger.
6. To clean secondary heat exchanger requires removing the section of vent piping within the furnace. Disconnect the 2 inch no-hub connector securing 2 inch PVC street elbow to outlet of secondary heat exchanger inside the furnace. Take whatever action necessary to then disconnect and remove the vertical 2 inch pipe section rising out of the furnace. This is necessary to permit secondary heat exchanger to be pulled out the front opening of furnace.
7. Disconnect wires to pressure switch, and unplug tubing from pressure switch to burner box (unplug at the burner box).
8. Disconnect the drain hose from the drain tube projecting through the cover panel.
9. Remove all the screws around the *edge* of the sheet metal panel that covers the secondary heat exchanger – **do not** remove the four (4) screws securing secondary heat exchanger to panel.
10. Gently work the secondary heat exchanger assembly forward out of the furnace being careful not to damage the fins.

11. Once the coil is removed from the furnace, take it to a place where the following steps can be performed.
 - A. Position coil so outlet cover box with 3/8" drain tube is at the bottom. Using a garden hose introduce a large volume of water into the upper opening, and run until water coming out bottom opening is clear. Shut water off and drain all water from coil.
 - B. Set coil on its back so inlet, outlet and drain openings are pointed up. Fill coil with hot soapy water (use common dishwashing detergent such as Dawn) , and let stand for 5 minutes. Shake coil vigorously and then pour out water. Repeat 2 more times.
 - C. Repeat Step A to final flush coil.
 - D. Rinse down outside of coil as necessary to assure fins are clear. **Do not** use a hard stream of water as this may damage the fins.
12. Reinstallation of all parts is done by reversing all of the above steps.

⚠ WARNING

High temperature silicone sealant/adhesive rated at least 450°F continuous must be used to reseat the 3 inch elbow fitting to both the inducer blower housing and the secondary heat exchanger. Failure to seal properly could result in improper furnace operation resulting in property damage, bodily injury, or death.

⚠ WARNING

The gas supply piping must be reconnected, and checked for leaks. Never use an open flame when testing for gas leaks. Use of an open flame could cause a fire or explosion resulting in property damage, bodily injury, or death.

After all inspections are made and the furnace is completely reassembled, and all electrical, gas, drain, air intake and vent connections are reconnected and verified, the furnace should be checked out for proper operation.

The general operation should be in accordance with that outlined in Section 26, Sequence of Operation.

Also, observe the main burners in operation. The flame should be mostly "blue" with possibly a little orange (not yellow) at the tips of the flame. The flames should be in the center of the heat exchanger compartments and not impinging on the heat exchanger surfaces themselves. See Figure 19

FIGURE 19

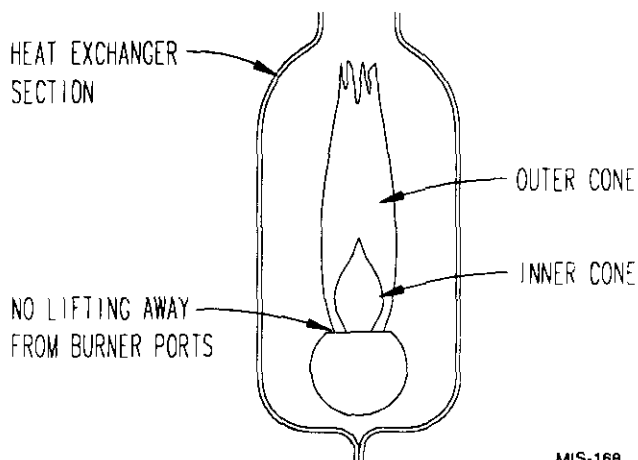

Observe the fire until the blower starts (there is a normal delay period until the heat exchanger warms up). There should be no change in the size or shape of the flame. If there is any wavering or blowing of the flame on blower start up, it is an indication of a possible leak in the heat exchanger.

SECTION 31 – REPLACEMENT PARTS

Replacement parts for the gas furnaces are available through local distributor.

Parts list covering all furnace components is shown in the Replacement Parts Manual. When ordering parts or making inquiries pertaining to any of the furnaces covered by these instructions, it is very important to always supply the **complete** model number and serial number of the furnace. This is necessary to assure that the correct parts (or an approved alternate part) are issued to the service agency.

LADDER DIAGRAM

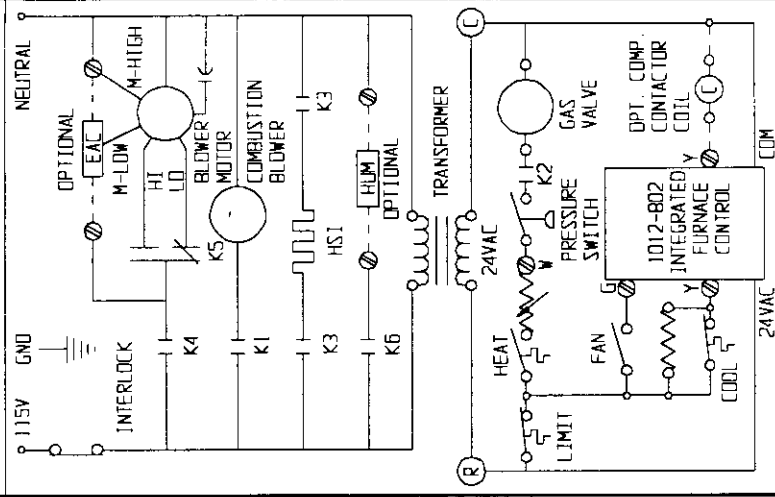

- NOTES:
1. USE COPPER CONDUCTORS ONLY.
 2. IF ANY OF THE ORIGINAL WIRE AS SUPPLIED WITH THE APPLIANCE MUST BE REPLACED, IT MUST BE REPLACED WITH WIRING MATERIAL HAVING A TEMPERATURE RATING OF AT LEAST 105°C.
 3. M1 AND M2 ARE PARK TERMINALS FOR UNUSED MOTOR SPEED LEADS.

⚠ DANGER
 * ELECTRIC SHOCK HAZARD
 * DISCONNECT POWER BEFORE SERVICING

CAPACITOR CHART

DCL065	5/370
DCL080	7.5/370
DCL095	15/370
DCL110	15/370

* ATOMIZING TYPE
 REQUIRES SALES SWITCH
 (SEE INSTRUCTIONS)

ELECTRONIC
 AIR CLEANER
 115 VAC SUPPLY

HUMIDIFIER *
 115 VAC SUPPLY

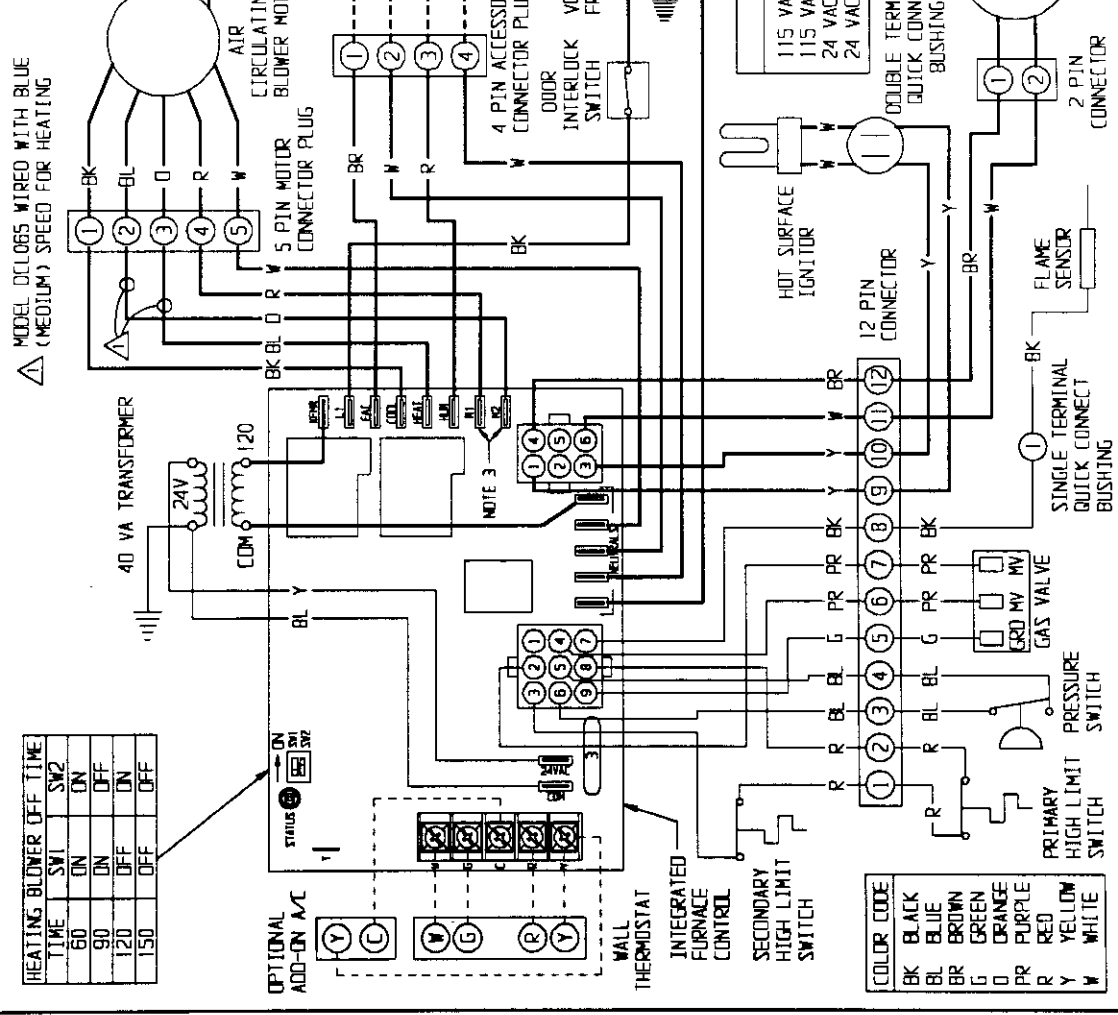

HEATING BLOWER OFF TIME

TIME	SW1	SW2
60	ON	ON
90	ON	OFF
120	OFF	ON
150	OFF	OFF

WIRING CODE

115 VAC	FACTORY
115 VAC	FIELD
24 VAC	FACTORY
24 VAC	FIELD

MOTOR SPEED COLOR CODE

COLOR	4 SPEED	3 SPEED
WHITE	COMMON	COMMON
RED	LOW	LOW
ORANGE	MED-LOW	MED
BLUE	MED-HIGH	HIGH
BLACK	HIGH	HIGH

COLOR CODE

BK	BLACK
BL	BLUE
BR	BROWN
G	GREEN
OR	ORANGE
PR	PURPLE
R	RED
Y	YELLOW
W	WHITE

DCL-MODELS 404B-15B

