

# INSTALLATION INSTRUCTIONS

---

## WALL MOUNTED CABINET AIR CONDITIONER WITH REFRIGERANT BASED LOW AMBIENT CONTROL

MODEL:  
CT241R



**BARDF MANUFACTURING COMPANY**  
Bryan, Ohio 43506

*Since 1914...Moving ahead, just as planned.*

Manual: 2100-337A  
Supersedes: 2100-337  
File: Volume II, Tab 15  
Date: 08-10-99

# Contents

---

<b>GENERAL INFORMATION</b> .....	<b>2</b>
CT Model Nomenclature .....	2
Shipping Damage .....	4
General .....	4
Duct Work .....	4
Installation Clearances .....	4
Filters .....	4
Condensate Drain .....	4
<b>INSTALLATION INSTRUCTIONS</b> .....	<b>5</b>
Wall Mounting Information .....	5
Mounting the Unit .....	5
Wiring – Main Power .....	5
Wiring – Low Voltage Wiring .....	5
How to Set an Adjustable Anticipator .....	11
Additional Information for Electric Heat or Heat Pump Applications .....	11
<b>START-UP</b> .....	<b>12</b>
Important Installer Note .....	12
Service Hints .....	12
Sequence of Operation .....	12
Compressor Control Module .....	12
Head Pressure Control .....	13
Head Pressure Control Valve Operation .....	13
Refrigerant Charge .....	13
Troubleshooting Refrigerant System .....	14
Pressure Service Ports .....	14
<b>TROUBLE SHOOTING</b> .....	<b>16</b>
Fan Blade Setting Dimensions .....	16
<b>WIRING DIAGRAMS</b> .....	<b>18</b>

## FIGURES

Figure 1 Unit Dimensions .....	3
Figure 2 Mounting Instructions .....	6
Figure 3 Mounting Instructions Using Optional MBC-2 Side Mounting Brackets .....	7
Figure 4 Common Wall Mounting Installations .....	8
Figure 5 Low Voltage Wiring .....	10
Figure 6 Setting Anticipator .....	11
Figure 7 Amprobe .....	11
Figure 8 Head Pressure Control Valve .....	13
Figure 9 Refrigerant Piping & Flow Diagram .....	14
Figure 10 Troubleshooting .....	15
Figure 11 Fan Blade Setting Dimensions .....	16

## TABLES

Table 1 Electric Heat Table .....	2
Table 2 .....	2
Table 3 Thermostat Wire Size .....	9
Table 4 Wall Thermostat and Subbase Combinations .....	9
Table 5 Fan Blade Setting Dimensions .....	16
Table 6 Indoor Blower Performance .....	16
Table 7 Maximum ESP of Operation (Electric Heat Only) .....	16
Table 8 Pressure Table .....	17

# Getting Other Information and Publications

---

These publications can help you install the air conditioner or heat pump. You can usually find these at your local library or purchase them directly from the publisher. Be sure to consult current edition of each standard.

National Electrical Code ..... ANSI/NFPA 70

Standard for the Installation ..... ANSI/NFPA 90A  
of Air Conditioning and  
Ventilating Systems

Standard for Warm Air ..... ANSI/NFPA 90B  
Heating and Air  
Conditioning Systems

Load Calculation for Residential ..... ACCA Manual J  
Winter and Summer  
Air Conditioning

Duct Design for Residential ..... ACCA Manual D  
Winter and Summer Air Conditioning  
and Equipment Selection

## For more information, contact these publishers:

**ACCA — Air Conditioning Contractors of America**  
1712 New Hampshire Avenue  
Washington, DC 20009  
Telephone: (202) 483-9370  
Fax: (202) 234-4721

**ANSI — American National Standards Institute**  
11 West Street, 13th Floor  
New York, NY 10036  
Telephone: (212) 642-4900  
Fax: (212) 302-1286

**ASHRAE — American Society of Heating  
Refrigerating, and Air Conditioning  
Engineers, Incorporated**  
1791 Tullie Circle, N.E.  
Atlanta, GA 30329-2305  
Telephone: (404) 636-8400  
Fax: (404) 321-5478

**NFPA — National Fire Protection Association**  
Batterymarch Park  
P.O. Box 9101  
Quincy, MA 02269-9901  
Telephone: (800) 344-3555  
Fax: (617) 984-7057

# CT Series General Information

## CT Model Nomenclature

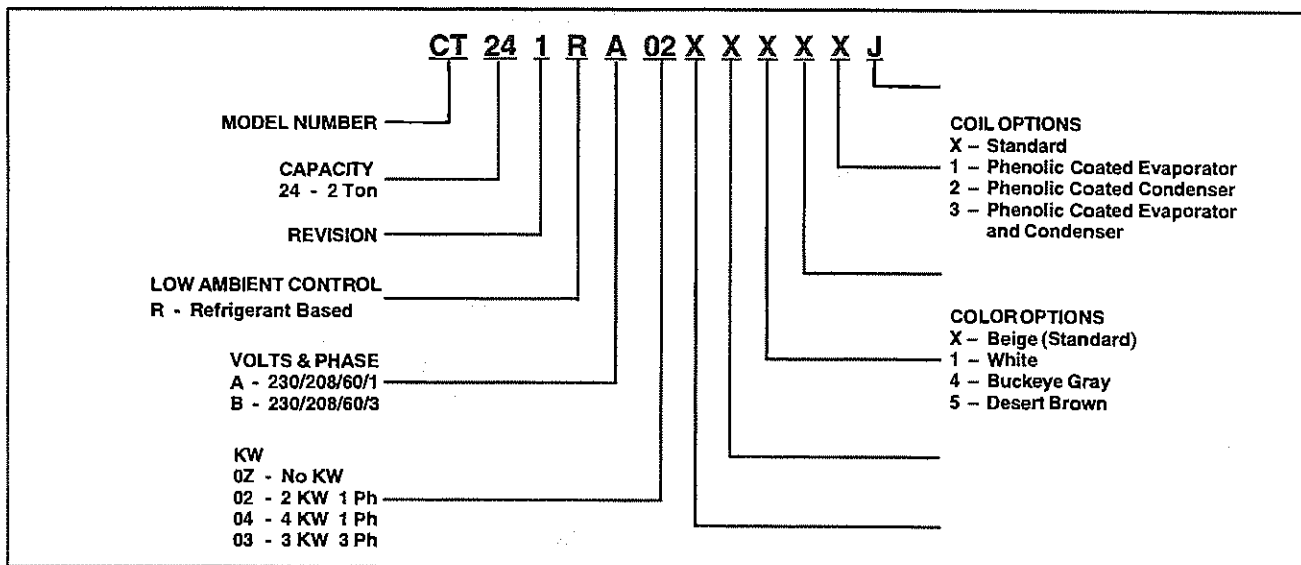


TABLE 1 - ELECTRIC HEAT TABLE

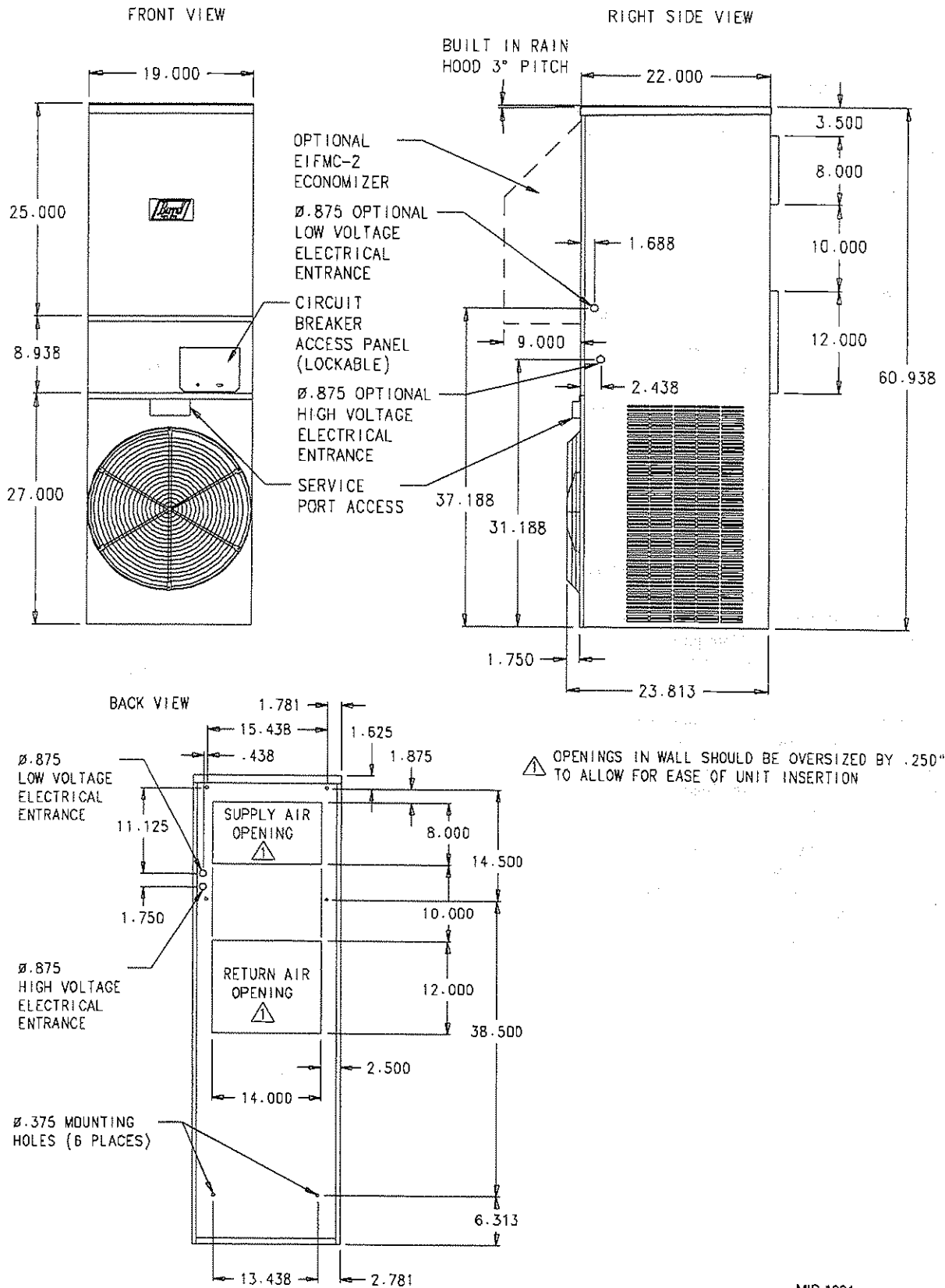
Models	CT241RA				CT241RB				
	240-1		208-1		240-1		208-1		
	KW	A	BTU	A	BTU	A	BTU	A	BTU
2	8.3	6800	7.2	5100					
4	16.7	13650	14.4	10230					
3					7.2	10240	6.3	7650	

TABLE 2

SINGLE CIRCUIT							
Model	Rated and Phase	No. Field Power Circuits	(3) Minimum Circuit Ampacity	(1) Maximum External Fuse or Circuit Breaker	(2) Field Power Wire Size	(2) Ground Wire Size	Unit Wiring Diagram
CT241RA0Z		1	19	30	12	12	4104-101
A02	230/208-1	1	19	30	12	12	4104-111
A04		1	24	30	10	10	4104-121
CT241RB0Z		1	14	20	14	12	4104-201
B03	230-208-3	1	14	20	14	12	4104-211

- (1) Maximum size of the time delay fuse or HACR type circuit breaker for protection of field wiring conductors.
- (2) Based on 75°C copper wire. All wiring must conform to NEC and all local codes.
- (3) These "Minimum Circuit Ampacity" values are to be used for sizing the field power conductors. Refer to the National Electrical Code (latest revision), Article 310 for power conductor sizing. **CAUTION:** When more than one field power conductor circuit is run through one conduit, the conductors must be derated. Pay special attention to Note 8 of Table 310 regarding Ampacity Adjustment Factors when more than 3 conductors are in a raceway.

**FIGURE 1 - UNIT DIMENSIONS**



MIS-1034

# GENERAL INFORMATION

---

## SHIPPING DAMAGE

Upon receipt of equipment, the carton should be checked for external signs of shipping damage. If damage is found, the receiving party must contact the last carrier immediately, preferably in writing, requesting inspection by the carrier's agent.

## GENERAL

The equipment covered in this manual is to be installed by trained, experienced service and installation technicians.

The refrigerant system is completely assembled and charged. All internal wiring is complete.

The unit is designed for use with or without duct work. Flanges are provided for attaching the supply and return ducts.

These instructions explain the recommended method to install the air cooled self-contained unit and the electrical wiring connections to the unit.

These instructions and any instructions packaged with any separate equipment required to make up the entire air conditioning system should be carefully read before beginning the installation. Note particularly "Starting Procedure" and any tags and/or labels attached to the equipment.

While these instructions are intended as a general recommended guide, they do not supersede any nation and/or local codes in any way. Authorities having jurisdiction should be consulted before the installation is made. See Page 1 for information on codes and standards.

Size of unit for a proposed installation should be based on heat loss calculation made according to methods of Air Conditioning Contractors of America (ACCA). The air duct should be installed in accordance with the Standards of the National Fire Protection Association for the Installation of Air Conditioning and Ventilating systems of Other Than Residence Type, NFPA No. 90A, and Residence Type Warm Air Heating and Air Conditioning Systems, NFPA No. 90B. Where local regulations are at a variance with instructions, installer should adhere to local codes.

## DUCT WORK

All duct work, supply and return, must be properly sized for the design air flow requirement of the equipment. Air Conditioning Contractors of America (ACCA) is an excellent guide to proper sizing. All duct work or portions thereof not in the conditioned space should be properly insulated in order to both conserve energy and prevent condensation or moisture damage.

Refer to Table 6 for maximum static pressure available for duct design.

Design the duct work according to methods given by the Air Conditioning Contractors of America (ACCA). When duct runs through unheated spaces, it should be insulated with a minimum of one inch of insulation. Use insulation with a vapor barrier on the outside of the insulation. Flexible joints should be used to connect the duct work to the equipment in order to keep the noise transmission to a minimum.

Ducts through the walls must be insulated and all joints taped or sealed to prevent air or moisture entering the wall cavity.

Duct work, if used is approved for zero (0) inches to combustibles.

## INSTALLATION CLEARANCES

Basic unit is approved for zero (0) inches to combustible to the rear of the unit.

## FILTERS

No filter is supplied with unit. A return filter grille is required (Bard Return Filter Grille RFGC-2) must be installed with a one inch washable filter (Bard Filter 7003-048). Both parts must be ordered separately.

## CONDENSATE DRAIN

A plastic drain hose extends from the drain pan at the top of the unit down to the unit base. There are openings in the unit base for the drain hose to pass through. In the event the drain hose is connected to a drain system of some type, it must be an open or vented type system to assure proper drainage.

# INSTALLATION INSTRUCTIONS

## WALL MOUNTING INFORMATION

1. These units are secured by mounting the unit to the outside wall surface from inside the unit. Field installed mounting brackets which secure the unit externally from both sides are available as accessory items.
2. On wood frame walls, the wall construction must be strong and rigid enough to carry the weight of the unit without transmitting any unit vibration. On wood frame walls, unit requires supply and return air sleeve.
3. Concrete block walls must be thoroughly inspected to insure that they are capable of carrying the weight of the unit to be installed.

## MOUNTING THE UNIT

1. Two holes for the supply and return air openings, must be cut through the wall as shown in Figure 2 on Page 6.
2. Locate and mark lag bolt locations and bottom mounting bracket location, if desired. (See Figure 2.)
3. Mount bottom mounting bracket if used. (Optional)
4. Hook top rain flashing under back bend of top. Top rain flashing is shipped attached to the back of the unit on the right side. (See Figure 2.)
5. Position unit in opening and secure with 5/16 lag bolts. Use 5/16 inch diameter flat washers on the lag bolts.
6. Secure rain flashing to wall and caulk across entire length of top. (See Figure 2.)
7. For additional mounting rigidity, the return air and supply air frames or collars can be drilled and screwed or welded to the structural wall itself (depending upon wall construction).

*NOTE: Approved for 0 inches clearance to combustible surfaces.*

8. On side by side installations, maintain a minimum of 3 inches clearance on side to allow proper airflow to outdoor coil.

Figure 4 on Page 8 illustrates some common wall mounting installations.

*NOTE: Optional side mounting brackets can be used. Secure brackets to cabinet using common side screws. Secure brackets to wall with 5/16 inch lag bolts and 5/16 inch diameter washers. (See Figure 3 on Page 7.)*

## WIRING – MAIN POWER

Refer to the unit rating plate for wire sizing information and maximum fuse or “HACR Type” circuit breaker size. Each outdoor unit is marked with a “Minimum Circuit Ampacity”. This means that the field wiring used must be sized to carry that amount of current. All models are suitable only for connection with copper wire. Each unit and/or wiring diagram will be marked “Use Copper Conductors Only”. These instructions *MUST* be adhered to. Refer to the National Electrical Code (NEC) for complete current carrying capacity data on the various insulation grades of wiring material. All wiring must conform to NEC and all local codes.

The electrical data lists fuse and wire sizes (75°C copper) for all models including the most commonly used heater sizes.

The unit rating plate lists a “Maximum Time Delay Relay Fuse” or “HACR Type” circuit breaker that is to be used with the equipment. The correct size must be used for proper circuit protection and also to assure that there will be no nuisance tripping due to the momentary high starting current of the compressor motor.

The disconnect access door on this unit may be locked to prevent unauthorized access to the disconnect. To convert for the locking capability, bend the tab located in the bottom left hand corner of the disconnect opening under the disconnect access panel straight out. This tab will now line up with the slot in the door. When shut a padlock may be placed through the hole in the tab preventing entry.

## WIRING – LOW VOLTAGE WIRING

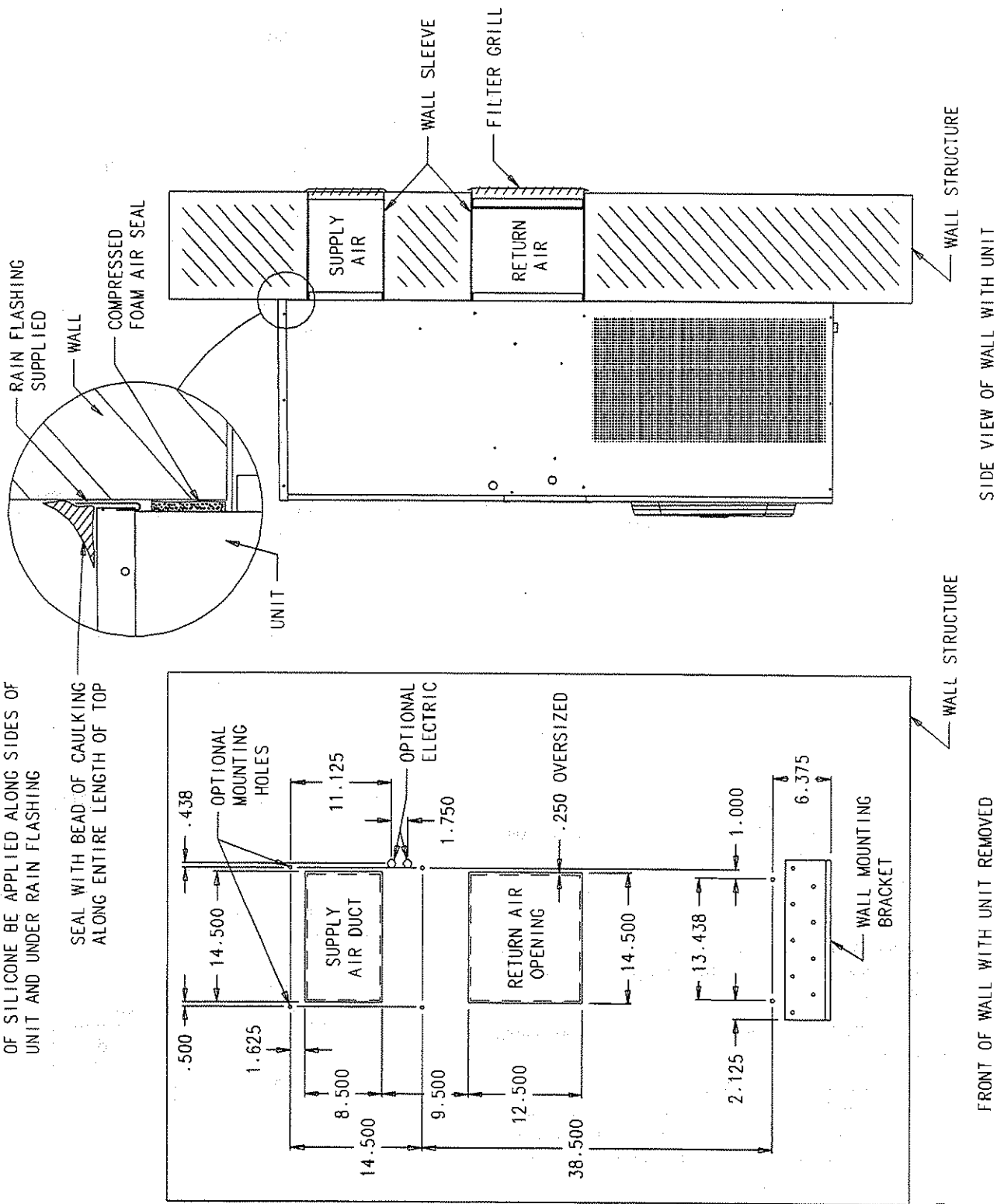
All models are equipped with dual primary voltage transformers. All equipment leaves the factory wired on 240V tap. For 208V operation, reconnect from 240V to 208V tap. The acceptable operating voltage range for the 240V and 208V taps are:

TAP	RANGE
240	253 -- 216
208	220 -- 187

*NOTE: The voltage should be measured at the field power connection point in the unit and while the unit is operating at full load (maximum amperage operating condition).*

**FIGURE 2 - MOUNTING INSTRUCTIONS**

NOTE: IT IS RECOMMENDED THAT A BEAD OF SILICONE BE APPLIED ALONG SIDES OF UNIT AND UNDER RAIN FLASHING

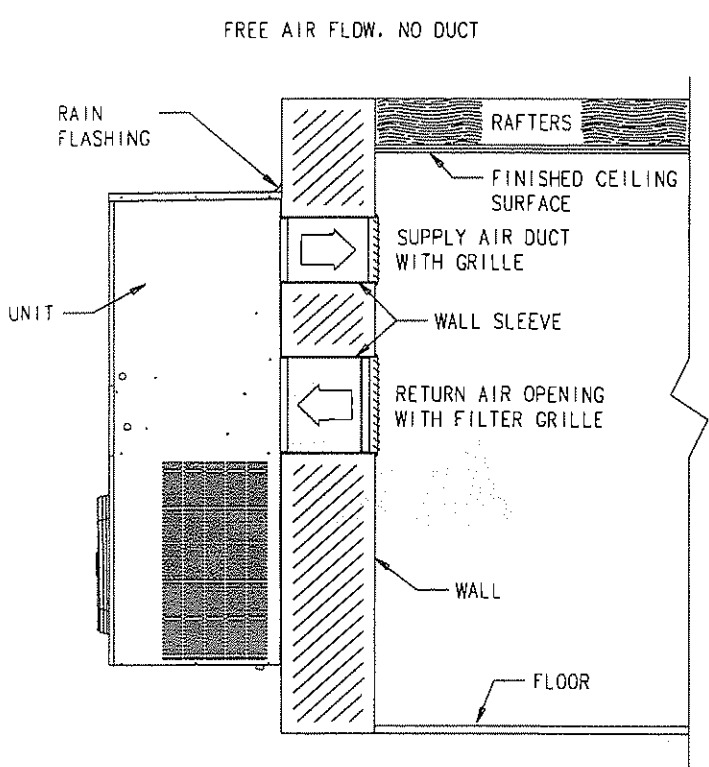


MIS-1151

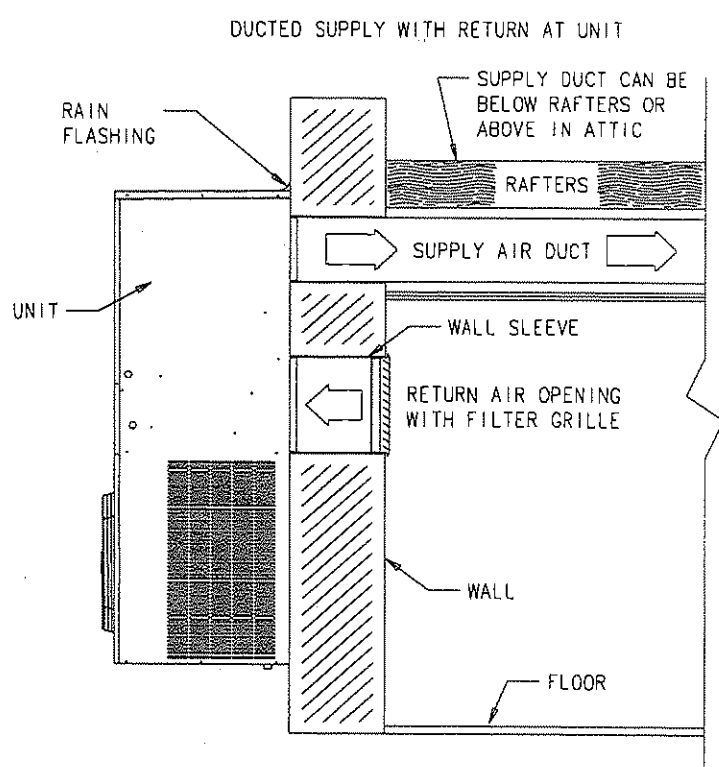




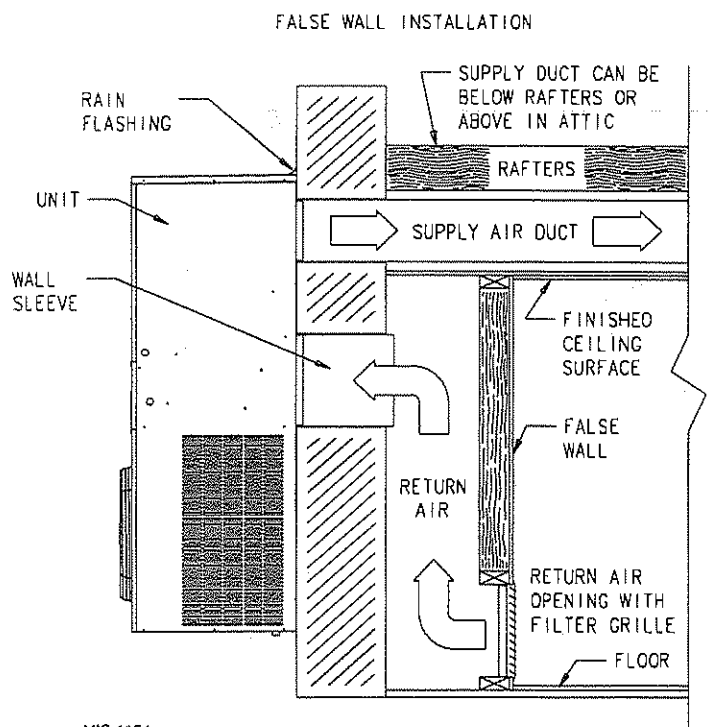
**FIGURE 4 - COMMON WALL MOUNTING INSTALLATIONS**



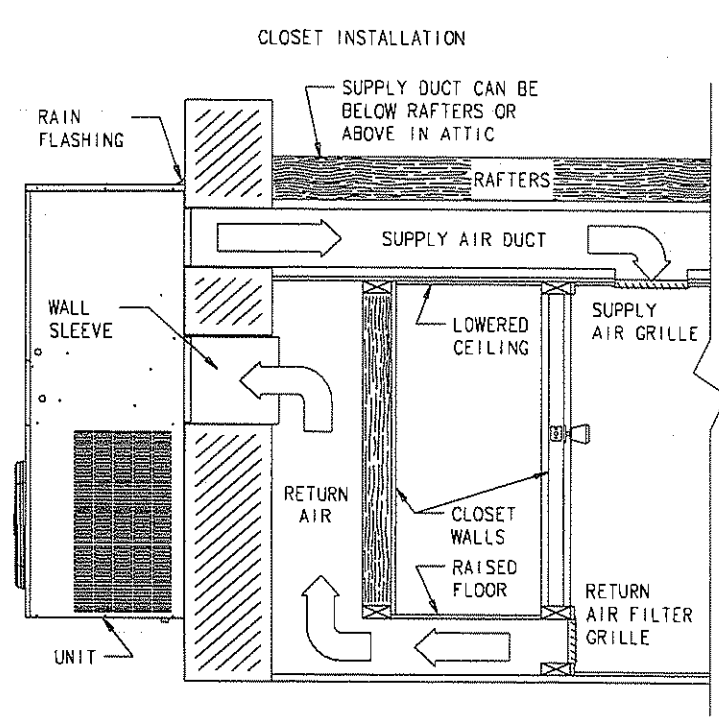
MIS-1152



MIS-1153



MIS-1154



MIS-1155

Four (4) wires should be run from thermostat subbase to the 24V terminal board in the unit. A four conductor, 18 gauge copper, color coded thermostat cable is recommended. The connection points are shown in Figure 5.

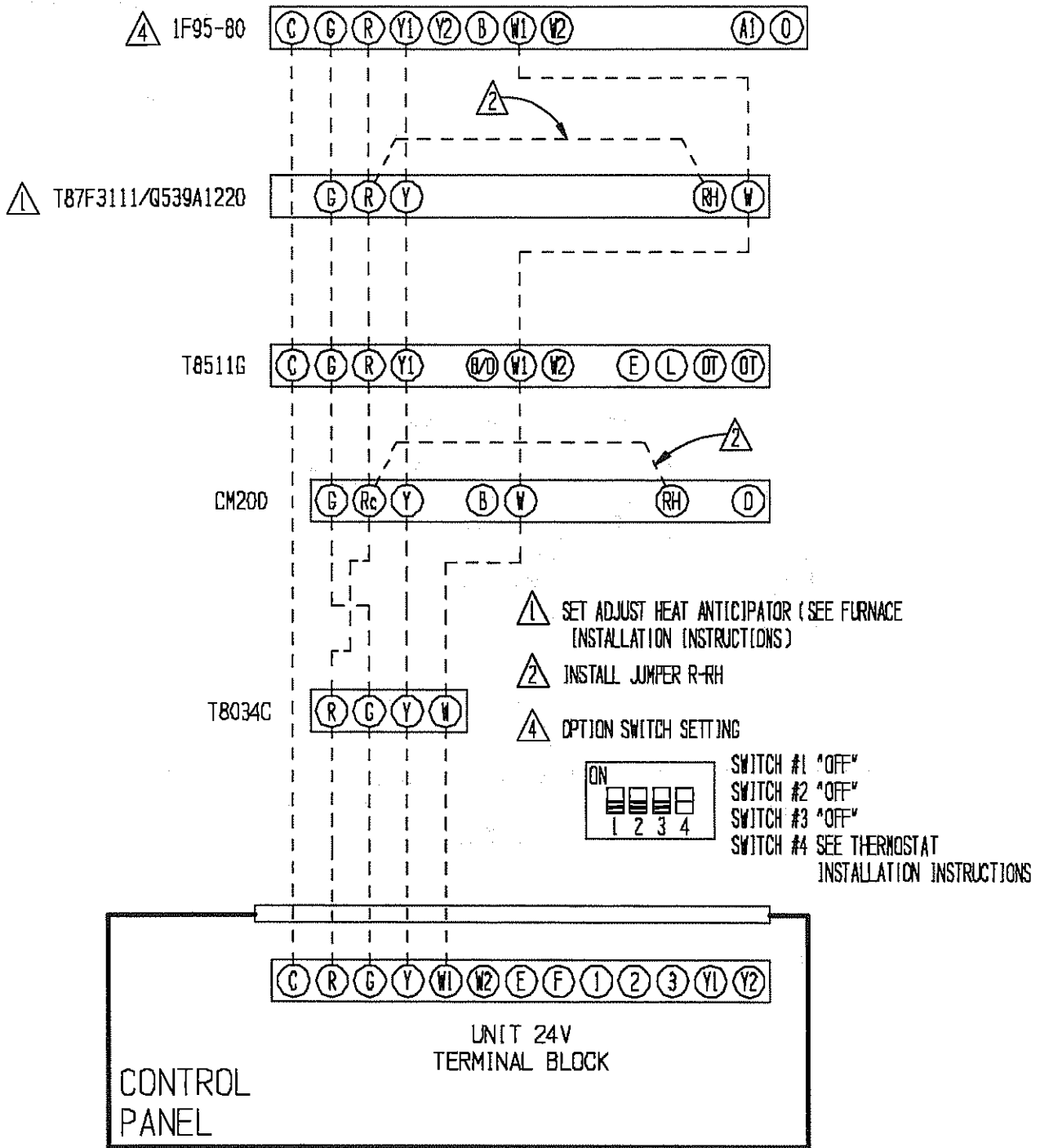
**TABLE 3 – THERMOSTAT WIRE SIZE**

Transformer VA	FLA	Wire Gauge	Maximum Distance In Feet
55	2.3	20 gauge	45
		18 gauge	60
		16 gauge	100
		14 gauge	160
		12 gauge	250

**TABLE 4 – WALL THERMOSTAT AND SUBBASE COMBINATIONS**

Thermostat	Subbase	Predominate Features
8403-002 T87F311	8404-003 Q539A1220	1 stage heat, 1 stage cool; Mercury System: heat-off-cool Fan: on-auto
8403-041 T8034-C	---	1 stage heat, 1 stage cool; Mercury System: heat-off-cool Fan: on-auto
8403-035 1F95-80	---	2 stage heat, 2 stage cool Programmable Electronic
8403-042 T8511G	---	2 stage heat, 1 stage cool System: heat-off-auto-cool Fan: on-auto Electronic
8403-043 CM200	---	1 stage heat, 1 stage cool System: heat-off-cool Fan: on-auto Snap Action

FIGURE 5 -- LOW VOLTAGE WIRING



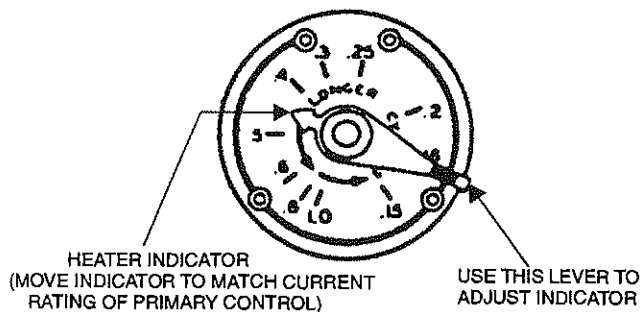
MIS-1162

## HOW TO SET AN ADJUSTABLE ANTICIPATOR

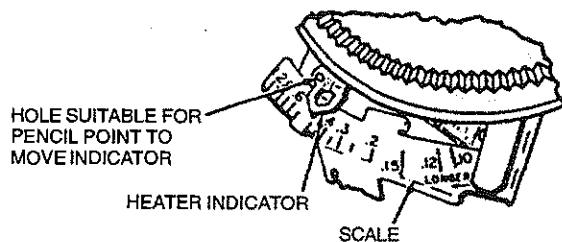
The primary purpose of the adjustable anticipator thermostat is to provide a single thermostat to match almost any type of primary control in the field today. Refer to thermostat instructions for details on thermostat set up.

The adjustable heat anticipator has a slide wire adjustment with the point scale marked in tenths of an ampere. This is used to set the anticipator to agree with the control amp draw of the control system in use. Refer to Figure 6.

**FIGURE 6  
SETTING ANTICIPATOR**



OR



If the primary control nameplate has no rating or if further adjustment is necessary, use the following procedure to determine the current draw of each stage:

The current draw of each heating stage must be measured with the thermostat removed and the power on.

1. Connect an AC ammeter of appropriate range between the heating terminals of the subbase.  
Stage 1 – between W1 and RH or R  
Stage 2 – between W2 and RH or R
2. Move the system switch to *HEAT* or *AUTO*.
3. After one minute, read the ammeter and record the reading.
4. After mounting the thermostat, set the adjustable heat anticipator(s) to match the respective reading(s) measured in Step 3.

If you want to change the cycle of the heating system you can make a simple adjustment on the anticipator to do this.

Additional adjustment, if necessary, may be made as follows:

*Heater cycles too short* – set adjustable heater to a slightly higher dial setting (1/2 division).

*Heater cycles too long* – set adjustable heater to a slightly lower dial setting (1/2 division).

Occasionally you may find a system where longer or shorter cycles of the primary control are desirable. If the primary control draws .45 amps and you want a longer cycle, set the anticipator to .5 or .6 amps. This puts *less* resistance in the circuit. With less resistance, but the same current (from the primary control), you will generate less “false” heat and get a longer cycle of the primary control.

If a setting .45 amps on the adjustable anticipator gives a cycle that is longer than desired, reset the indicator to .3 or .25 amps. This will put *more* resistance in the circuit and thus generate more “false” heat for shorter cycle.

## ADDITIONAL INFORMATION FOR ELECTRIC HEAT OR HEAT PUMP APPLICATIONS

Adjust heat anticipator to match current rating of heating relay for W1 (and W2 if 2 stage). Move indicator on the scale to correspond with this current rating.

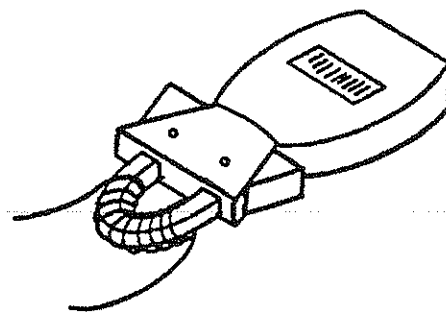
If the current rating is not given, proceed as follows:

1. Wrap exactly 10 loops of thermostat wire (W1) around the prongs of an Amprobe. (See Figure 7.)
2. Let the heating system operate for one minute before reading the W1 or W2 current draw.
3. Divide the reading obtained in Step 2 by 10.
4. Use the value calculated in Step 3 to set the heat.
5. Repeat the procedure for W2 if 2 stage heat anticipator.

**Example: 6.0 Amp**

$$\frac{6.0 \text{ Amp}}{10 \text{ loops}} = .6\text{A}$$

**FIGURE 7**



**NOTE:** Cooling anticipators on all thermostat are fixed and do not require setting.

## IMPORTANT INSTALLER NOTE

For improved start-up performance, wash the indoor coil with a dish detergent.

## SERVICE HINTS

1. Caution building owner/operator to maintain clean air filters at all times; also not to needlessly close off supply and return air registers. This reduces air flow through the system which shortens equipment service life as well as increasing operating costs.
2. Check all power fuses or circuit breakers to be sure they are the correct rating.
3. Periodic cleaning of the outdoor coil to permit full and unrestricted airflow circulation is essential.

## SEQUENCE OF OPERATION

### COOLING

Circuit R-Y makes at thermostat pulling in compressor contactor, starting the compressor and outdoor motor. The G (indoor motor) circuit is automatically completed on any call for cooling operation or can be energized by manual fan switch on subbase for constant air circulation. On a call for heating, circuit R-W1 make at the thermostat pulling in heat contact for the strip heat and blower operation.

All models are equipped with a two speed outdoor fan which is controlled by an outdoor thermostat. When the outdoor conditions are above 90° F, the fan will run on high speed. Below 90° F the fan will run on low speed.

## COMPRESSOR CONTROL MODULE

All models are equipped with a compressor control module. This control is an anti-short cycle/lockout timer with high and low pressure switch monitoring and alarm relay output.

## MODE OF OPERATION

### Delay on Make Timer

- On initial power up, or any time the power is interrupted to the unit, the delay on make period begins. This delay will be 2 minutes plus 10% of the delay on break setting. This feature assures that pressures will be equalized for normal start up if there are brief power interruptions, and can accommodate staggered starts for dual unit installations as long as the off delay periods are set differently for the two units.

- During routine operation of the unit with no power interruptions the compressor will operate on demand with no delay.
- Adjustable 30 second to 5 minute delay on break timer assures that pressures can equalize if units are short cycled by the operating controls or personnel. Recommended settings would be 2 minutes for Unit 1 and 3 minutes for Unit 2.

### High Pressure Switch and Lockout Sequence

- If the high pressure switch opens the compressor contactor will de-energize immediately. The lockout timer in the CCM will go into a soft lockout and stay locked out until the high pressure switch closes and the delay on break has expired.
- If the high pressure switch opens again during the same operating cycle the CCM will go into a manual lockout condition and the alarm relay will energize.
- Recycling the wall thermostat resets the manual lockout.

### Low Pressure Switch, Bypass and Lockout Sequence

- If the low pressure switch opens for more than 120 seconds the compressor contactor will de-energize after the delay on break time has expired.
- Regardless of the state of the low pressure switch the compressor contactor will reenergize after the delay on break time has expired.
- If the low pressure switch remains open, or opens again for longer than 120 seconds, the CCM will go into a manual lockout and the alarm relay circuit will energize.
- Recycling the wall thermostat resets the manual lockout.

**NOTE:** Both high and low pressure switch controls are inherently automatic reset devices. The high pressure switch opens at 425 and closes at 325 psig, and the low pressure switch opens at 14 and closes at 30 psig. The lockout features, both soft and manual, are a function of the Compressor Safeguard Control.

### Alarm Relay Output

- Alarm terminal is 24V AC output connection for applications where alarm relay is employed. This terminal is powered whenever compressor is in manual lockout due to high pressure or low pressure sequences as described.

## HEAD PRESSURE CONTROL

Design of air conditioning system utilizing air cooled condensing units involves two main problems which must be solved if the system is to operate reliably and economically . . . high ambient and low ambient operation. If the condensing unit is properly sized, it will operate satisfactorily during extremely high ambient temperatures. However, since most units will be required to operate at ambient temperatures below their design dry bulb temperature during most of the year, the solution to low ambient operation is more complex.

Without good head pressure control during low ambient operation, the system can experience both running cycle and off-cycle problems. Two running cycle problems are of prime concern:

1. Since the pressure differential across the thermostatic expansion valve port affects the rate of refrigerant flow, low head pressure generally causes insufficient refrigerant to be fed to the evaporator.
2. Failure to have sufficient head pressure will result in low suction pressure and/or iced evaporator coils.

The primary off-cycle problem is the possible inability to get the system on-the-line if the refrigerant has migrated to the condenser. Insufficient flow through the TXV will cause a low suction pressure which results in compressor cycling.

When low ambient conditions are encountered during operation on air cooled systems with the resultant drop in condensing surface results in a raised in condensing pressure and sufficient liquid line pressure for normal system operation.

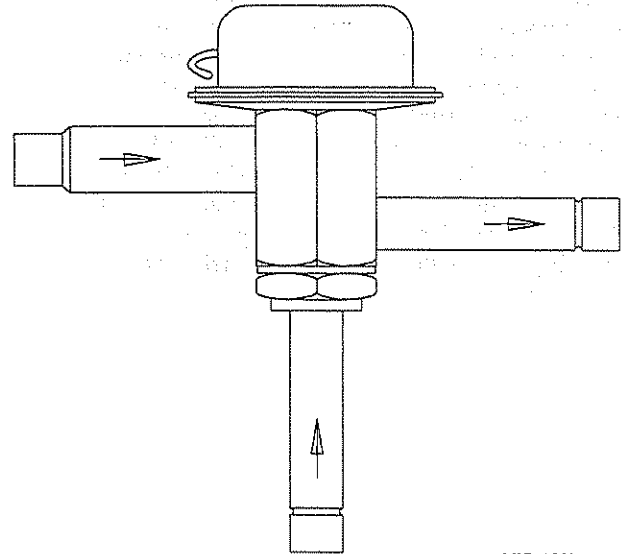
The head pressure control valve is used in conjunction with a receiver to allow for proper head pressure control. Any system using hot gas for capacity control must have a normal head pressure to operate properly.

### HEAD PRESSURE CONTROL VALVE OPERATION

The head pressure control is a three-way modulating valve controlled by the discharge pressure. The charged dome exerts a constant pressure on top of the diaphragm. At high ambient air temperature bypass gas entering Port B is allowed under the diaphragm where it counteracts the pressure of the dome charge. This upward push on the diaphragm allows the seat disc to seal against the top seat, preventing flow from Part B (discharge gas) while flow from Port C is unrestricted. (Refer to Figure 8.)

An ambient air temperature falls, and uncontrolled air cooled condenser will exhibit a corresponding decrease in head pressure. As the discharge (bypass) pressure falls, it no longer counteracts the dome charge pressure and the diaphragm moves downward, moving the push rod and seat towards the bottom seat.

FIGURE 8  
HEAD PRESSURE CONTROL VALVE



MIS-1267

**IMPORTANT:** This allows discharge (bypass) gas to be metered into condenser outlet. The higher pressure at the condenser outlet reduces the flow from Port C and caused the level of condensed liquid to rise in the condenser.

The flooding of the condenser with liquid reduces the available condensing surface. The result is to increase the pressure in the condenser and maintain an adequate high side pressure

### REFRIGERANT CHARGE

When "refrigerant side" head pressure control is utilized on a system, two additional considerations must be completely analyzed. First of all, there must be the correct amount of refrigerant to flood the condenser at the lowest expected ambient and still have enough charge in the system for proper operation. A shortage of refrigerant will cause hot gas to enter the liquid line and the expansion valve, and refrigeration will cease. Too much charge doesn't cause any operating difficulties during the low ambient season;

however, this will cause high head pressures during the summer season when head pressure control is not required.

Secondly, the receiver must have sufficient capacity to hold all of the liquid refrigerant in the system, since it will be returned to the receiver when high ambient conditions prevail. If the receiver is too small, liquid refrigerant will be held back in the condenser during the high ambient conditions and excessively high discharge pressure will be experienced.

The receiver has been sized to hold the necessary amount of refrigerant required during light load conditions so the head pressure control system can function properly, and also to accommodate the surplus charge that occurs under periods of normal loading at the warmer outdoor temperatures. Any erratic operating during light load conditions either inside or outside could be attributed to an undercharge of refrigerant even though the unit may operate normally at higher temperatures. Because of the complexity of the system design and operation, the only way to assure correct system charge and operating characteristics over the entire design operating range of the unit is to completely recharge the system with the total amount of R-22 shown on the unit serial plate after proper leak test and evacuation procedures have been followed.

## TROUBLESHOOTING THE REFRIGERANT SYSTEM

Troubleshooting the refrigerant system can be quite complicated because of the number of refrigerant valves in the system. There is a device installed in the system to aid in this process:

1. A liquid line sight glass is located directly above the filter-drier. If a solid column of refrigerant is not present during normal operation, and undercharge or defective pressure differential valve should be suspected.

Please refer to Figure 10 on page 14, Refrigerant System Trouble-shooting Guide, for complete details.

## PRESSURE SERVICE PORTS

High and low pressure service ports are installed on all units so that the system operating pressures can be observed. Pressure curves can be found later in the manual covering all models. It is imperative to match the correct pressure curve to the unit by model number.

**FIGURE 9  
REFRIGERANT PIPING AND FLOW DIAGRAM**

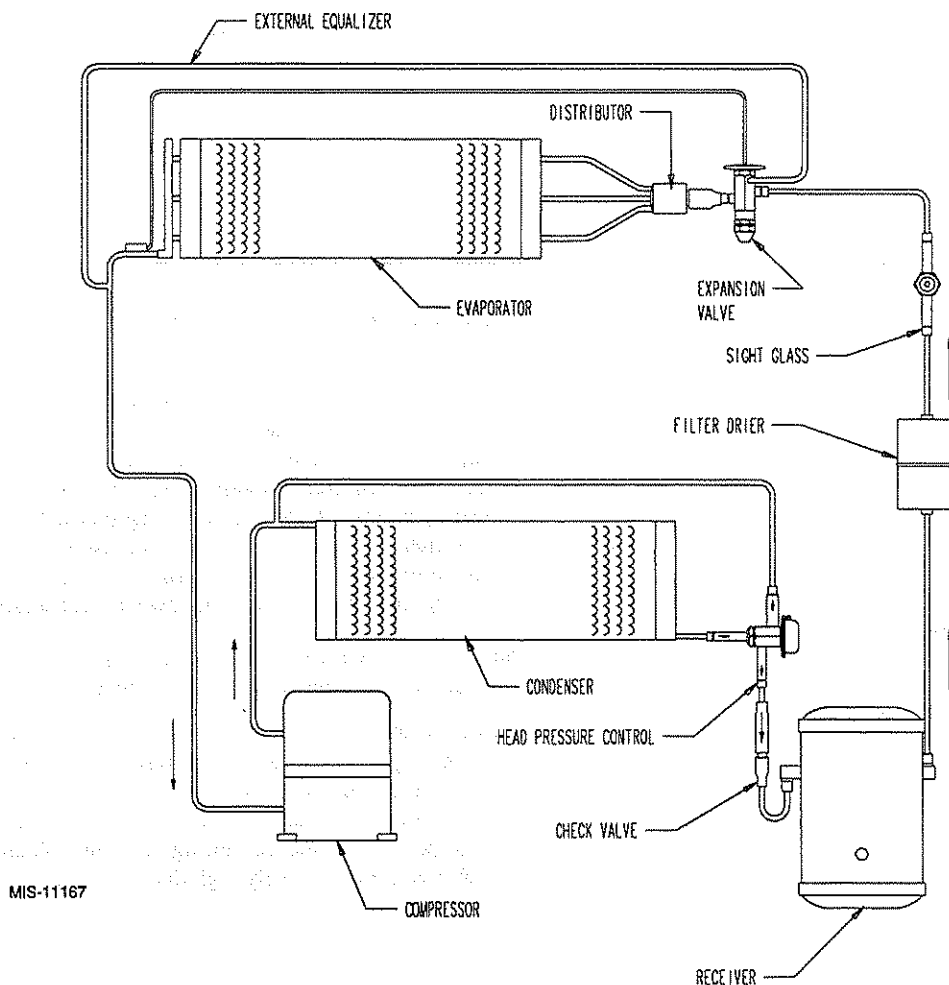
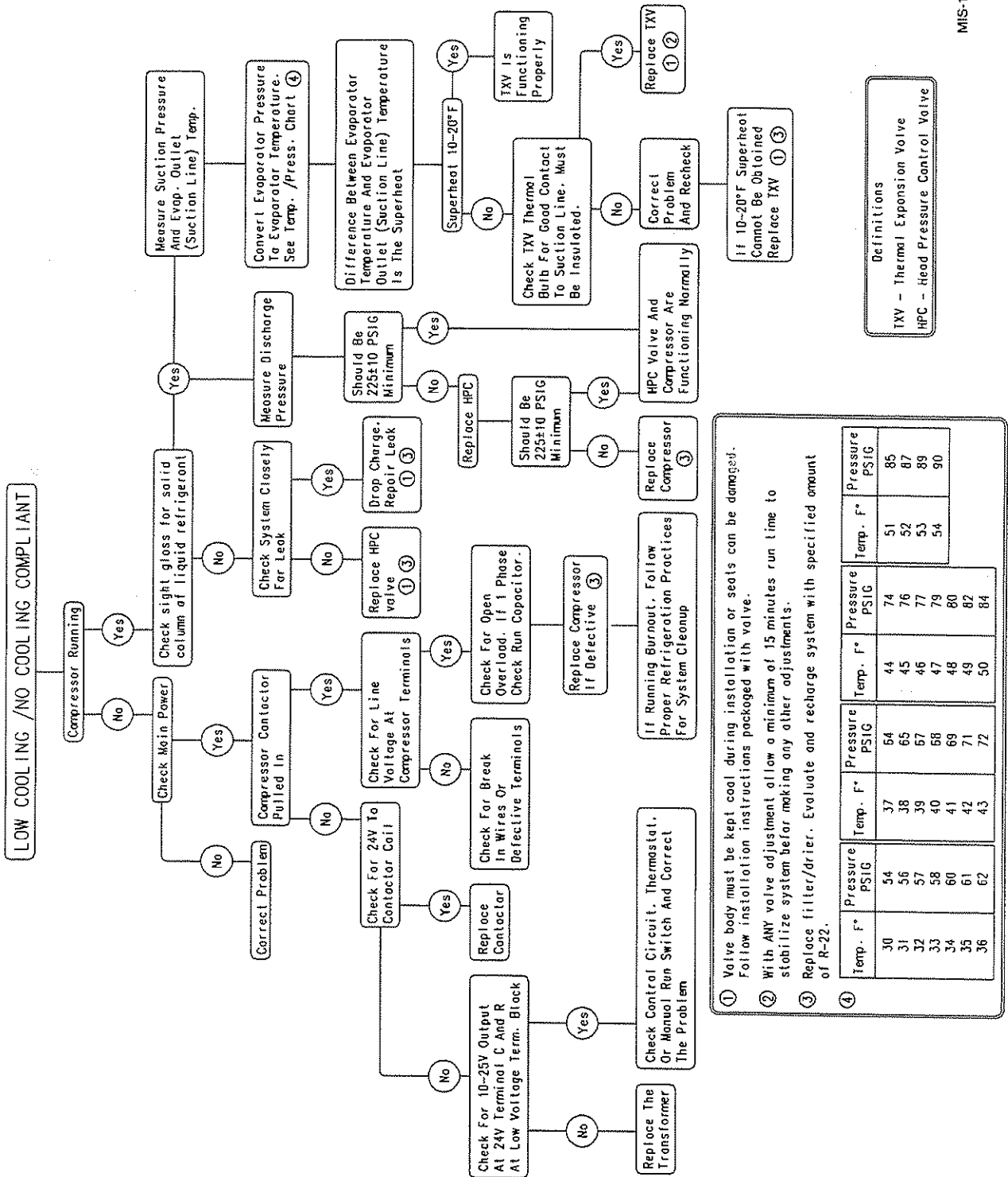




FIGURE 10



MIS-1266

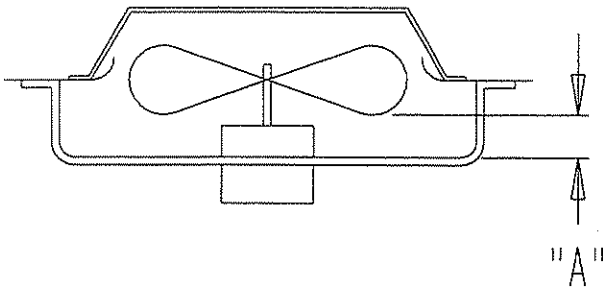
# TROUBLE SHOOTING

## FAN BLADE SETTING DIMENSIONS

Shown in the drawing below are correct fan blade setting dimensions for proper air delivery across the outdoor coil.

Any service work requiring removal or adjustment in the fan and/or motor area will require that the dimensions below be checked and blade adjusted in or out on the motor shaft accordingly.

**FIGURE 11 - FAN BLADE SETTING DIMENSIONS**



**TABLE 5**

Model	Dimension A
CT241	1.00

**TABLE 6**

## INDOOR BLOWER PERFORMANCE - CFM @ 230V

No return filter grille or filter				
E.S.P.	Medium Speed Dry	Medium Speed Wet	High Speed Dry	High Speed Wet
0.0.	1,012	980	1,070	1,038
0.1	925	893	982	950
0.2	859	827	924	892
0.3	794	763	855	823
0.4	722	690	775	743
0.5	642	610	694	662
0.6	537	505	598	566
With return filter grille and 1" washable filter				
E.S.P.	Medium Speed Dry	Medium Speed Wet	High Speed Dry	High Speed Wet
0.0.	847	815	880	848
0.1	760	728	792	760
0.2	694	662	734	702
0.3	629	597	665	633
0.4	557	525	585	553
0.5	477	445	504	472
0.6	372	340	408	376

*NOTE: Reduce airflow by 30 CFM for 208V operation.*

**TABLE 7**

## MAXIMUM ESP OF OPERATION ELECTRIC HEAT ONLY

Model	ESP
ALL	.60

TABLE 8

**COOLING**

**Air Temperature Entering Outdoor Coil Degree °F**

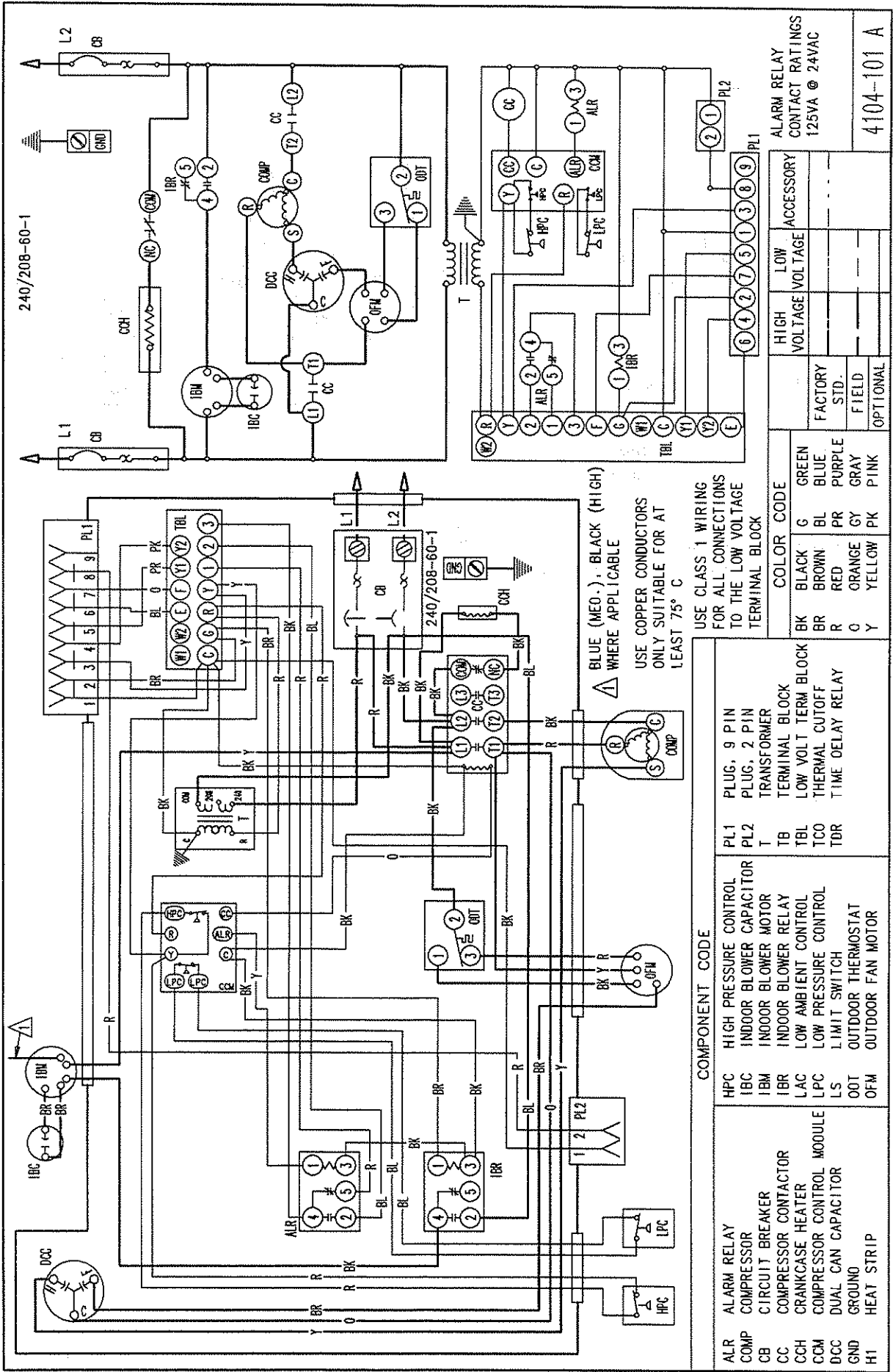
Model	Return Air Temperature	Pressure	-20	-10	0	10	20	30	40	50	60	70	80	90	100	110	120	130
CT241R	75 deg. DB 57 deg. WB	Low Side	61	61	62	62	63	63	63	63	63	63	63	64	65	67	69	73
		High Side	228	230	232	235	237	239	241	243	245	247	251	263	284	314	355	411
	80 deg. DB 67 deg. WB	Low Side	66	66	66	67	67	67	68	68	68	68	68	69	70	71	73	77
		High Side	233	235	237	238	238	239	240	240	241	241	256	274	296	322	360	420
	85 deg. DB 72 deg. WB	Low Side	69	69	70	70	70	71	71	71	72	72	74	74	75	77	79	83
		High Side	242	242	243	243	245	245	247	247	249	255	265	284	307	334	372	428

Low side pressure ± 2 PSIG

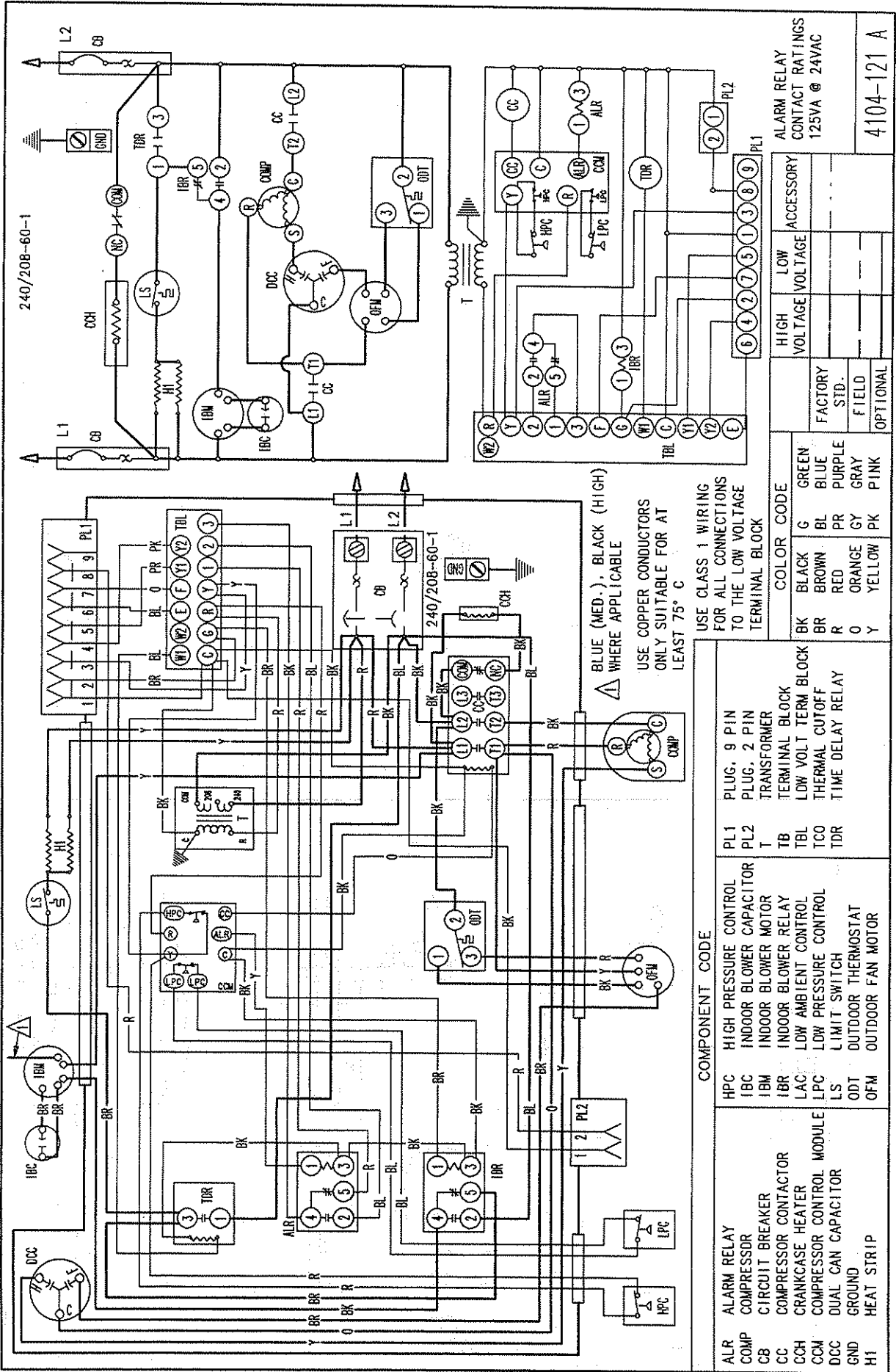
High side pressure ± 5 PSIG

Tables are based upon rated CFM (airflow) across the evaporator coil. If there is any doubt as to correct operating charge being in the system, the charge should be removed, system evacuated, and recharged to serial plate instructions.

7960-427







240/208-60-1

BLUE (MED.), BLACK (HIGH)  
WHERE APPLICABLE  
USE COPPER CONDUCTORS  
ONLY SUITABLE FOR AT  
LEAST 75° C

USE CLASS 1 WIRING  
FOR ALL CONNECTIONS  
TO THE LOW VOLTAGE  
TERMINAL BLOCK

COMPONENT CODE

ALR	ALARM RELAY	PL1	PLUG, 9 PIN
COMP	COMPRESSOR	PL2	PLUG, 2 PIN
CB	CIRCUIT BREAKER	T	TRANSFORMER
CC	COMPRESSOR CONTACTOR	TB	TERMINAL BLOCK
CCM	CRANKCASE HEATER	TBL	LOW VOLT TERM BLOCK
CCH	COMPRESSOR CONTROL MODULE	TCC	THERMAL CUTOFF
DCC	DUAL CAN CAPACITOR	TDR	TIME DELAY RELAY
GND	GROUND		
H1	HEAT STRIP		

COLOR CODE	
BK	BLACK
BR	BROWN
R	RED
O	ORANGE
Y	YELLOW
G	GREEN
BL	BLUE
PR	PURPLE
GY	GRAY
PK	PINK

HIGH VOLTAGE	LOW VOLTAGE	ACCESSORY
FACTORY STD.	FIELD	OPTIONAL

ALARM RELAY  
CONTACT RATINGS  
125VA @ 24VAC  
4104-121 A



