

---

# INSTALLATION INSTRUCTIONS

---

## WALL MOUNTED PACKAGE HEAT PUMPS

MODELS  
WH381  
WH431  
WH491



Bard Manufacturing Company  
Bryan, Ohio 43506

*Since 1914...Moving ahead, just  
as planned.*

Manual : 2100-342  
File: Volume III Tab 17  
Date: 08-24-98

© Copyright 1998

# Contents

---

<b>Getting Other Informations and Publications</b> .....	1
<b>Wall Mount General Information</b> .....	2
Heat Pump Wall Mount Model Nomenclature .....	2
Shipping Damage .....	4
General .....	4
Duct Work .....	5
Filters .....	5
Fresh Air Intake .....	5
Condensate Drain – Evaporator .....	6
Condensate Drain – Condenser .....	6
<b>Installation Instructions</b> .....	7
Wall Mounting Information .....	7
Mounting the Unit .....	7
Wiring – Main Power .....	12
Wiring – Low Voltage Wiring .....	12
Compressor Cutoff Thermostat and Outdoor Thermostats .....	13
Heat Anticipation .....	13
Thermostat Indicator Lamps .....	13
Emergency Heat Position .....	14
Compressor Malfunction Light .....	14
<b>Start Up</b> .....	15
Important Installer Note .....	15
Crankcase Heaters .....	15
High Pressure Switch .....	15
Two Speed Outdoor Fan Motors .....	15
Three Phase Scroll Compressor Start Up .....	15
Phase Monitor .....	16
Service Hints .....	16
Sequence of Operation .....	16
Pressure Service Ports .....	16
Defrost Cycle .....	16
<b>Troubleshooting</b> .....	18
Solid State Heat Pump Control Troubleshooting Procedure .....	18
Checking Temperature Sensor Outside Unit Circuit .....	19
Fan Blade Setting Dimensions .....	20
Removal of Fan Shroud .....	20
Refrigerant Charge .....	20
Pressure Tables .....	21

## Figures

Figure 1 Unit Dimensions .....	3
Figure 2 Fresh Air Damper Assembly .....	5
Figure 3 Condensate Drains .....	6
Figure 4 Mounting Instructions .....	8
Figure 4A Electric Heat Clearance .....	9
Figure 5 Wall Mounting Instructions .....	10
Figure 6 Wall Mounting Instructions .....	10
Figure 7 Common Wall Mounting Installations .....	11
Figure 8 Unit 24V Terminal Board .....	12
Figure 9 Compressor Cutoff and Outdoor Thermostat Wiring .....	13
Figure 10 Compressor Cutoff and Outdoor Thermostat Wiring .....	13
Figure 11 Start Up Procedure Decal .....	15
Figure 12 Defrost Control Board .....	17
Figure 13 Fan Blade Setting .....	20

## Tables

Table 2 Fuse, HACR Breakers, Wire Size .....	4
Table 3 Thermostat Wire Size .....	12
Table 4 Wall Thermostat and Subbase Combinations .....	14
Table 5 Troubleshooting .....	18
Table 6 Fan Blade Dimensions .....	20
Table 7 System Charge Ratings .....	20
Table 8 Rated CFM and Rated ESP .....	20
Table 9 Indoor Blower Performance .....	20
Table 11 Pressure Table .....	21
Table 12 Pressure Table .....	21

# Getting Other Information and Publications

These publications can help you install the air conditioner or heat pump. You can usually find these at your local library or purchase them directly from the publisher. Be sure to consult current edition of each standard.

National Electrical Code ..... ANSI/NFPA 70

Standard for the Installation ..... ANSI/NFPA 90A  
of Air Conditioning and  
Ventilating Systems

Standard for Warm Air ..... ANSI/NFPA 90B  
Heating and Air  
Conditioning Systems

Load Calculation for ..... ACCA Manual J  
Residential Winter and  
Summer Air Conditioning

Duct Design for Residential ..... ACCA Manual D  
Winter and Summer Air Conditioning  
and Equipment Selection

## For more information, contact these publishers:

**ACCA — Air Conditioning Contractors of America**  
1712 New Hampshire Ave. N.W.  
Washington, DC 20009  
Telephone: (202) 483-9370  
Fax: (202) 234-4721

**ANSI — American National Standards Institute**  
11 West Street, 13th Floor  
New York, NY 10036  
Telephone: (212) 642-4900  
Fax: (212) 302-1286

**ASHRAE — American Society of Heating  
Refrigerating, and  
Air Conditioning Engineers, Incorporated**  
1791 Tullie Circle, N.E.  
Atlanta, GA 30329-2305  
Telephone: (404) 636-8400  
Fax: (404) 321-5478

**NFPA — National Fire Protection Association**  
Batterymarch Park  
P.O. Box 9101  
Quincy, MA 02269-9901  
Telephone: (800) 344-3555  
Fax: (617) 984-7057

# WALL MOUNT GENERAL INFORMATION

## HEAT PUMP WALL MOUNT MODEL NOMENCLATURE

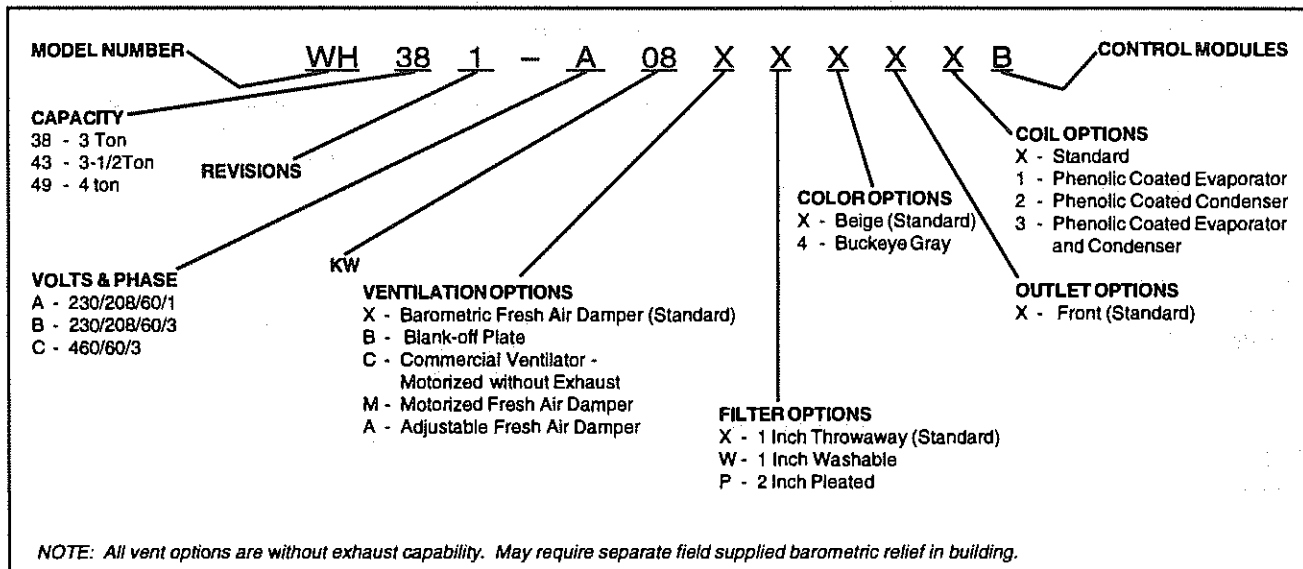



**TABLE 2  
ELECTRICAL SPECIFICATIONS**

Model	SINGLE CIRCUIT						DUAL CIRCUIT							
	Rated Volts & Phase	No. Field Power Circuits	③ Minimum Circuit Ampacity	① Maximum External Fuse or Ckt. Breaker	② Field Power Wire Size	② Ground Wire Size	③ Minimum Circuit Ampacity		① Maximum External Fuse or Ckt. Breaker		② Field Power Wire Size		② Ground Wire Size	
							CKT A	CKT B	CKT A	CKT B	CKT A	CKT B	CKT A	CKT B
WA381-A00, A0Z	230/208-1	1	31	45	8	10	---	---	---	---	---	---	---	---
WA381-B00, B0Z	230/208-3	1	23	35	8	10	---	---	---	---	---	---	---	---
WA431-A00, A0Z	230/208-1	1	34	50	8	10	---	---	---	---	---	---	---	---
WA431-B00, B0Z	230/208-3	1	25	35	8	10	---	---	---	---	---	---	---	---
WA491-A00, A0Z	230/208-1	1	40	60	8	10	---	---	---	---	---	---	---	---
WA491-B00, B0Z	230/208-3	1	29	45	10	10	---	---	---	---	---	---	---	---

- ① Maximum size of the time delay fuse or HACR type circuit breaker for protection of field wiring conductors.
- ② Based on 75° C copper wire. All Wiring must conform to NEC and all local codes.
- ③ These "minimum Circuit Ampacity" values are to be used for sizing the field power conductors. Refer to the National Electric Code (latest revision), article 310 for power conductor sizing. **CAUTION:** When more than one field power conductor circuit is run thru one conduit, the conductors must be derated. Pay special attention to note 8 of table 310 regarding Ampacity Adjustment Factors when more than 3 conductors are in a raceway.

## SHIPPING DAMAGE

Upon receipt of equipment, the carton should be checked for external signs of shipping damage. If damage is found, the receiving party must contact the last carrier immediately, preferably in writing, requesting inspection by the carrier's agent.

## GENERAL

The equipment covered in this manual is to be installed by trained, experienced service and installation technicians.

The refrigerant system is completely assembled and charged. All internal wiring is complete.

The unit is designed for use with or without duct work. Flanges are provided for attaching the supply and return ducts.

These instructions explain the recommended method to install the air cooled self-contained unit and the electrical wiring connections to the unit.

These instructions and any instructions packaged with any separate equipment, required to make up the entire air conditioning system should be carefully read before beginning the installation. Note particularly "Starting Procedure" and any tags and/or labels attached to the equipment.

While these instructions are intended as a general recommended guide, they do not supersede any national and/or local codes in any way. Authorities having jurisdiction should be consulted before the installation is made. See Page I for information on codes and standards.

Size of unit for a proposed installation should be based on heat loss calculation made according to methods of Air Conditioning Contractors of America (ACCA). The air duct should be installed in accordance with the Standards of the National Fire Protection Association for the Installation of Air Conditioning and Ventilating Systems of Other Than Residence Type, NFPA No. 90A, and Residence Type Warm Air Heating and Air Conditioning Systems, NFPA No. 90B. Where local regulations are at a variance with instructions, installer should adhere to local codes.

## DUCT WORK

Any heat pump is more critical of proper operating charge and an adequate duct system than a straight air conditioning unit. All duct work, supply and return, must be properly sized for the design air flow requirement of the equipment. Air Conditioning Contractors of America (ACCA) is an excellent guide to proper sizing. All duct work or portions thereof not in the conditioned space should be properly insulated in order to both conserve energy and prevent condensation or moisture damage.

Design the duct work according to methods given by the Air Conditioning Contractors of America (ACCA). When duct runs through unheated spaces, it should be insulated with a minimum of one inch of insulation. Use insulation with a vapor barrier on the outside of the insulation. Flexible joints should be used to connect the duct work to the equipment in order to keep the noise transmission to a minimum.

A 1/4 inch clearance to combustible material for the first three feet of duct attached to the outlet air frame is required. See Wall Mounting Instructions and Figures 3 and 3A for further details.

Ducts through the walls must be insulated and all joints taped or sealed to prevent air or moisture entering the wall cavity.

Some installations may not require any return air duct. A metallic return air grille is required with installations not requiring a return air duct. The spacing between louvers on the grille shall not be larger than 5/8 inch.

*NOTE: If no return air duct is used, applicable installation codes may limit this cabinet to installation only in a single story structure.*

Any grille that meets with 5/8 inch louver criteria may be used. It is recommended that Bard Return Air Grille Kit RG2 through RG5 or RFG2 through RFG5 be installed when no return duct is used. Contact distributor or factory for ordering information. If using a return air filter grille, filters must be of sufficient size to allow a maximum velocity of 400 fpm.

## FILTERS

A 1 inch throwaway filter is supplied with each unit. The filter slides into position making it easy to service. This filter can be serviced from the outside by removing the service door. A 1 inch washable filter and a 2 inch pleated filter are also available as optional accessories. The internal filter brackets are adjustable to accommodate the 2 inch filter by bending down the two horizontal tabs on each filter bracket.

## FRESH AIR INTAKE

All units are built with fresh air inlet slots punched in the service panel.

If the unit is equipped with a fresh air damper assembly, the assembly is shipped already attached to the unit. The damper blade is locked in the closed position. To allow the damper to operate, the maximum and minimum blade position stops must be installed. See Figure 2.

All capacity, efficiency and cost of operation information as required for Department of Energy "Energyguide" Fact Sheets is based upon the fresh air Blank-off plate in place and is recommended for maximum energy efficiency.

The blank-off plate is available upon request from the factory and is installed in place of the fresh air damper shipped with each unit.

**FIGURE 2  
FRESH AIR DAMPER**

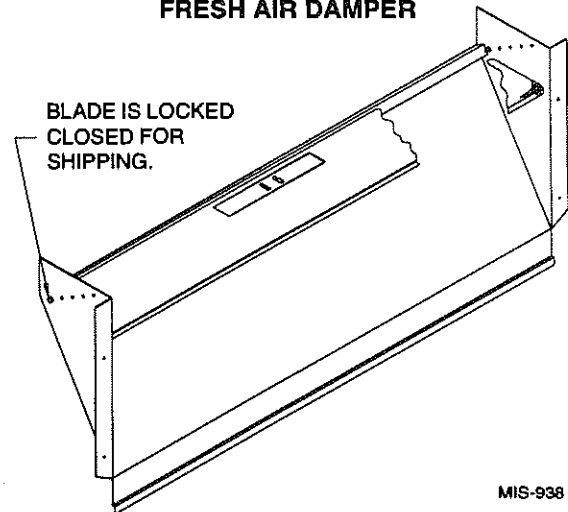

MIS-938

## CONDENSATE DRAIN – EVAPORATOR

A plastic drain hose extends from the drain pan at the top of the unit down to the unit base. There are openings in the unit base for the drain hose to pass through. In the event the drain hose is connected to a drain system of some type, it must be an open or vented type system to assure proper drainage.

## CONDENSATE DRAIN – CONDENSER

A hole is provided in the unit base to accept a Drain Connection Kit 8620-160. This allows connection of the unit base pan to a drain if so desired. (See Figure 3 and instructions provided with the 8620-160 kit.) In the event the drain hose is connected to a drain system of some type, it must be an open or vented type system to assure proper drainage.

**FIGURE 3  
CONDENSATE DRAINS**

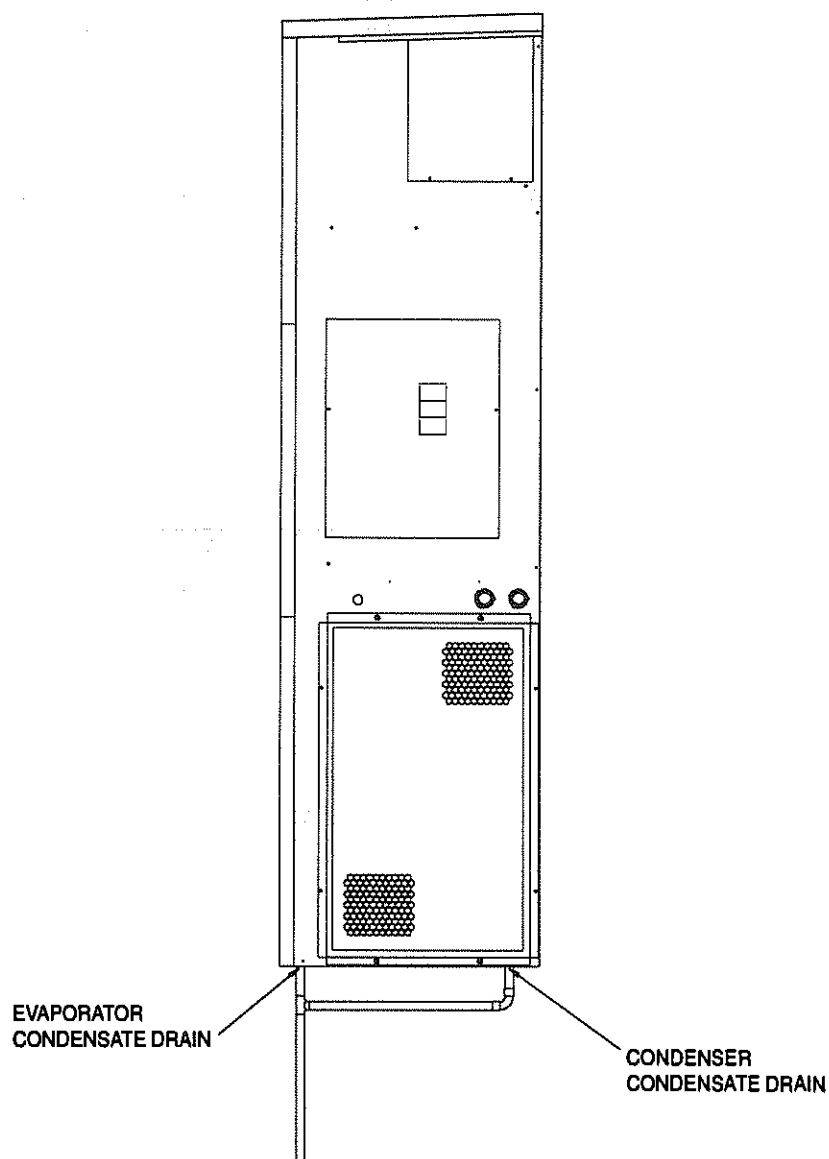

MIS-1278



# INSTALLATION INSTRUCTIONS

## WALL MOUNTING INFORMATION

1. Two holes for the supply and return air openings must be cut through the wall as shown in Figure 4.
2. On wood frame walls, the wall construction must be strong and rigid enough to carry the weight of the unit without transmitting any unit vibration.

### **WARNING**

Fire hazard can result if 1/4 inch clearance to combustible materials for supply air duct is not maintained. See Figure 4.

3. Concrete block walls must be thoroughly inspected to insure that they are capable of carrying the weight of the installed unit.

## MOUNTING THE UNIT

1. These units are secured by wall mounting brackets which secure the unit to the outside wall surface at both sides. A bottom mounting bracket is provided for ease of installation, but is not required.
2. The unit itself is suitable for 0 inch clearance, but the supply air duct flange and the first 3 feet of supply air duct require a minimum of 1/4 inch clearance to combustible material. If a combustible wall use a minimum of 30-1/2" x 10-1/2" dimensions for sizing. However it is generally recommended that a 1 inch clearance is used for ease of installation and maintaining the required clearance to combustible material. The supply air opening would then be 32" x 12". See Figures 4 and 4A for details.

### **WARNING**

Failure to provide the 1/4 inch clearance between the supply duct and a combustible surface for the first 3 feet of duct can result in fire causing property damage, injury or death.

3. Locate and mark lag bolt locations and bottom mounting bracket location. See Figure 4.
4. Mount bottom mounting bracket.
5. Hook top rain flashing under back bend of top. Top rain flashing is shipped with unit attached to back of unit on the right side.
6. Position unit in opening and secure with 5/16 lag bolts; use 3/4 inch diameter flat washers on the lag bolts.
7. Secure rain flashing to wall and caulk across entire length of top. See Figure 4.
8. For additional mounting rigidity, the return air and supply air frames or collars can be drilled and screwed or welded to the structural wall itself (depending upon wall construction). Be sure to observe required clearance if combustible wall.
9. On side by side installations, maintain a minimum of 20 inches clearance on right side to allow access to control panel and heat strips, and to allow proper airflow to the outdoor coil. Additional clearance may be required to meet local or national codes.

**FIGURE 4  
MOUNTING INSTRUCTIONS**

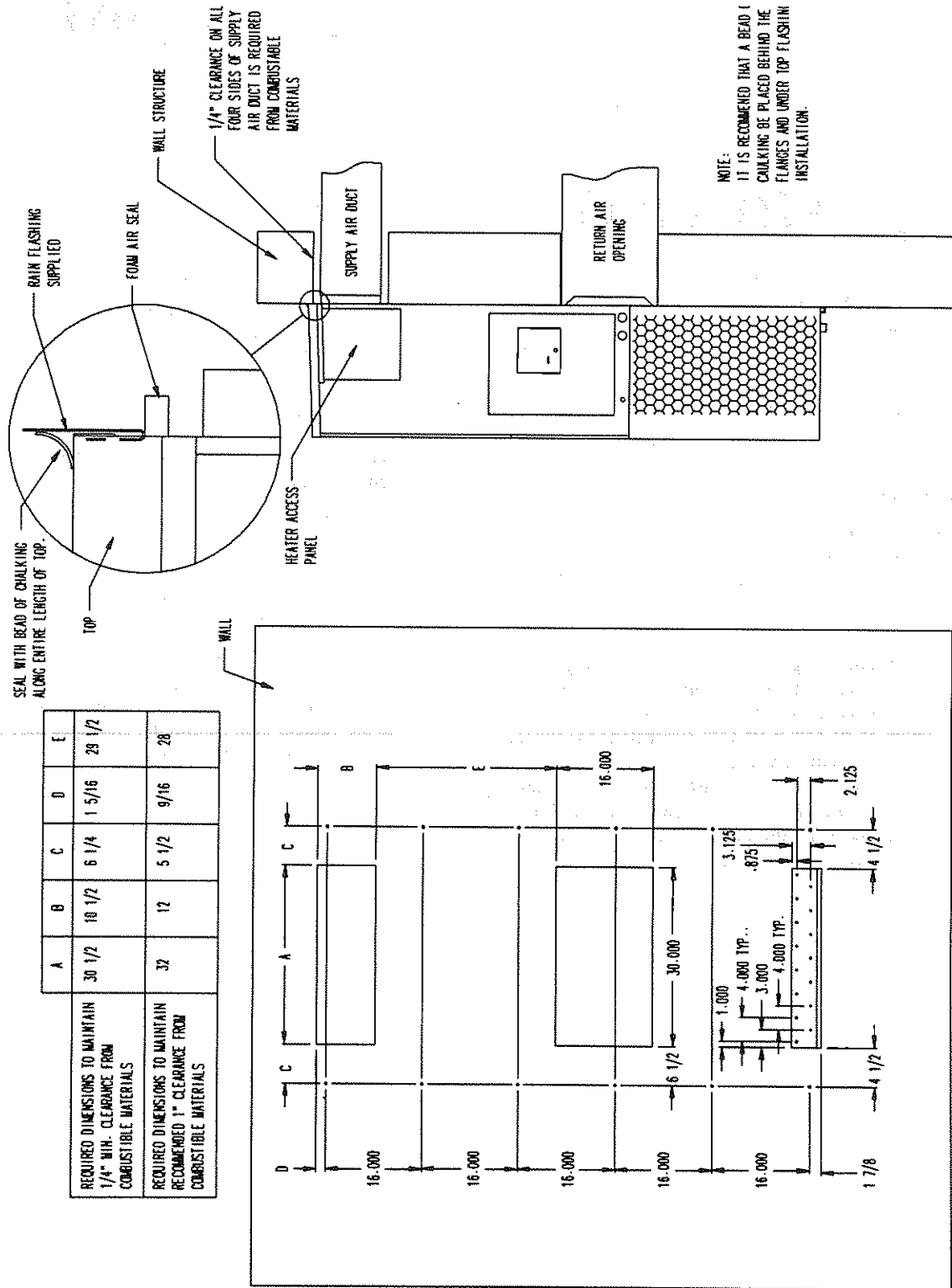

**FIGURE 4A**  
**ELECTRIC HEAT CLEARANCE**

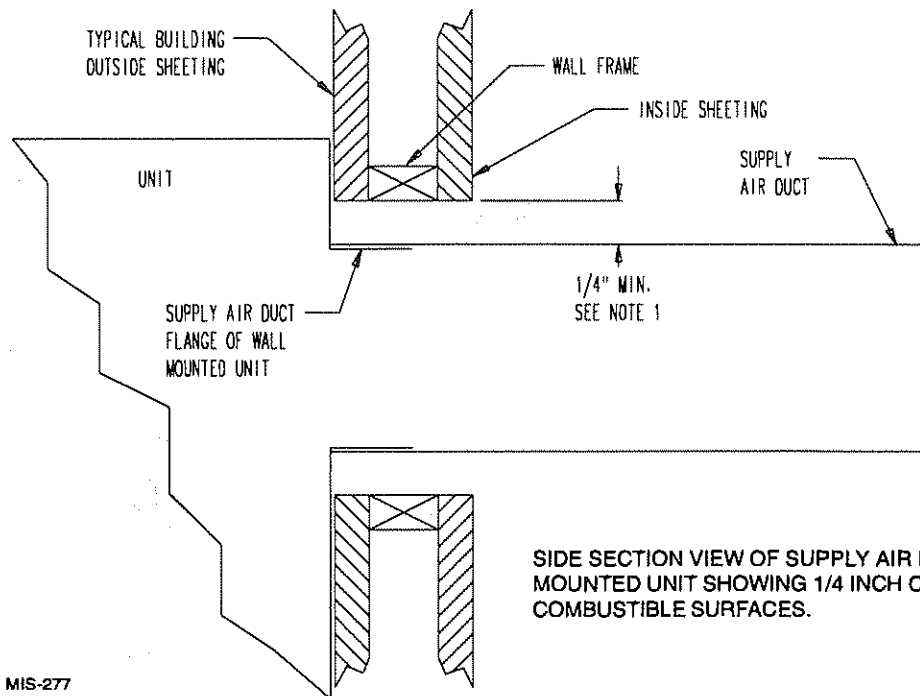

**SIDE SECTION VIEW OF SUPPLY AIR DUCT FOR WALL MOUNTED UNIT SHOWING 1/4 INCH CLEARANCE TO COMBUSTIBLE SURFACES.**

MIS-277

## **WARNING**

A minimum of 1/4 inch clearance must be maintained between the supply air duct and combustible materials. This is required for the first 3 feet of ducting.

It is important to insure that the 1/4 inch minimum spacing is maintained at all points.

Failure to do this could result in overheating the combustible material and may result in a fire causing property damage, injury or death.

**FIGURE 5  
WALL MOUNTING INSTRUCTIONS**

SEE FIGURE 4 - MOUNTING INSTRUCTIONS

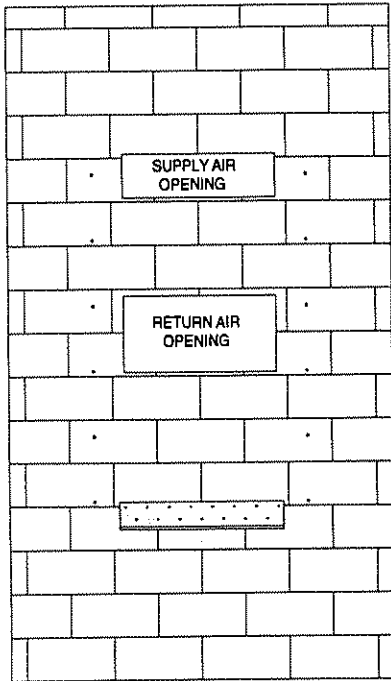

CONCRETE BLOCK WALL INSTALLATION

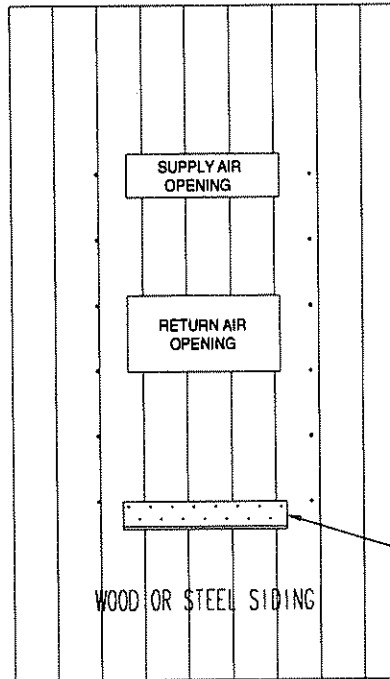

WOOD FRAME WALL INSTALLATION

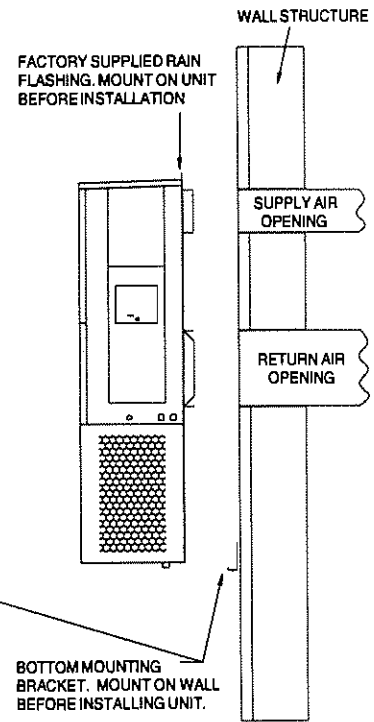

MIS-548

**FIGURE 6  
WALL MOUNTING INSTRUCTIONS**

SEE UNIT DIMENSIONS, FIGURE 1,  
FOR ACTUAL DIMENSIONS

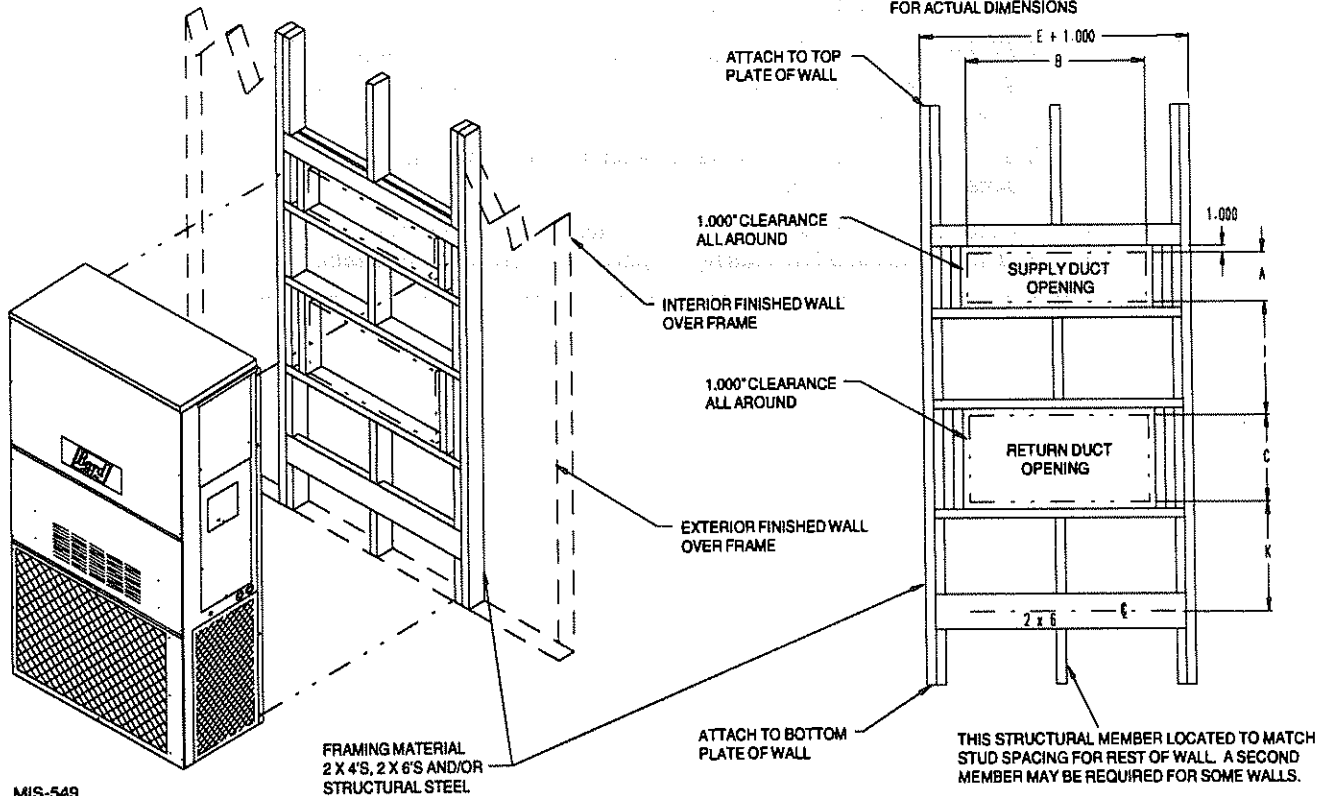

MIS-549

**FIGURE 7  
COMMON WALL MOUNTING INSTALLATIONS**

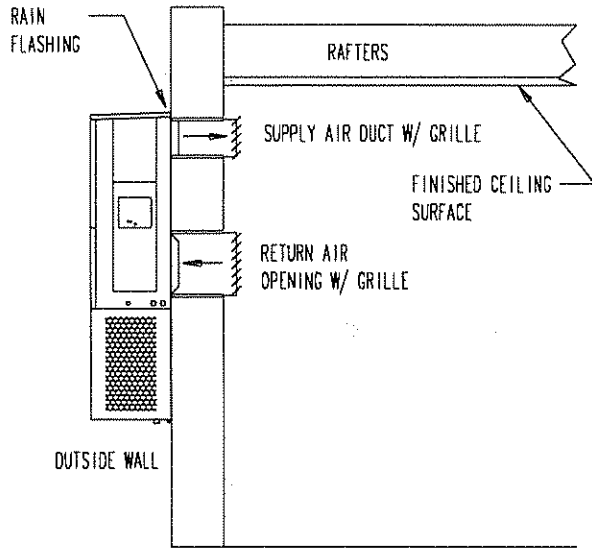

**FREE AIR FLOW NO DUCT**

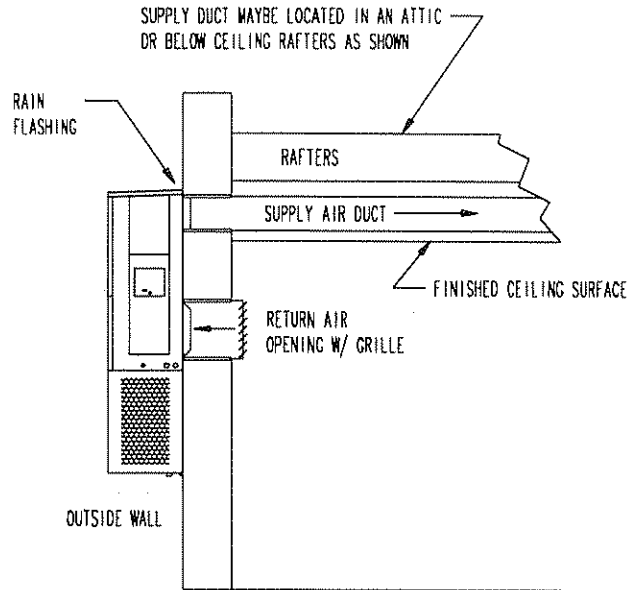

**DUCTED SUPPLY RETURN AT UNIT**

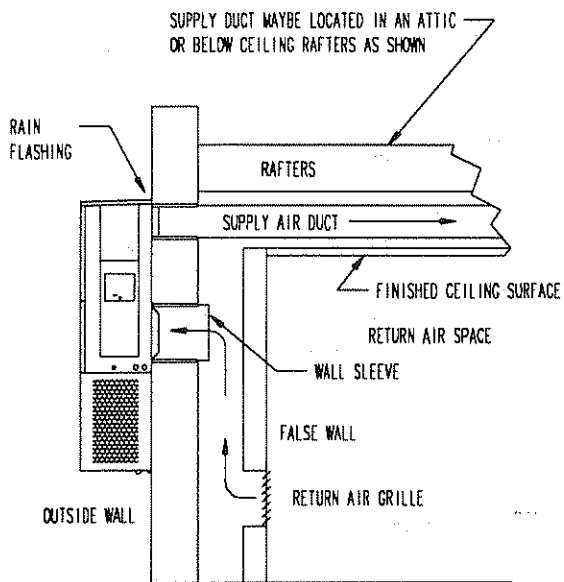

**FALSE WALL INSTALLATION**

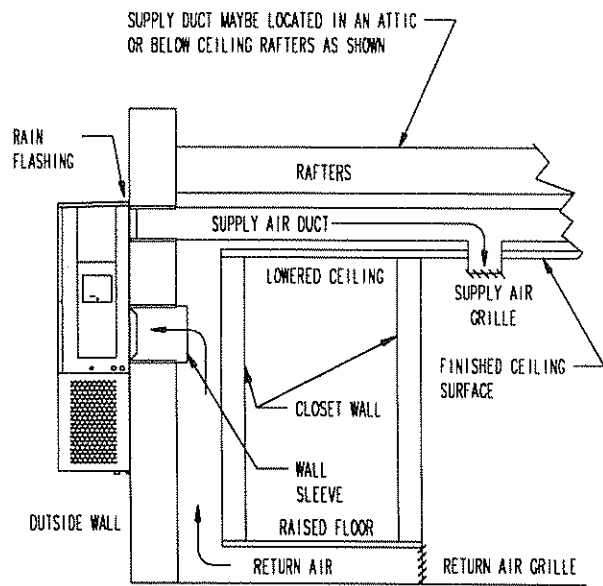

**CLOSET INSTALLATION**

## WIRING – MAIN POWER

Refer to the unit rating plate for wire sizing information and maximum fuse or "HACR" type circuit breaker size. Each outdoor unit is marked with a "Minimum Circuit Ampacity". This means that the field wiring used must be sized to carry that amount of current. Depending on the installed KW of electric heat, there may be two field power circuits required. If this is the case, the unit serial plate will so indicate. All models are suitable only for connection with copper wire. Each unit and/or wiring diagram will be marked "Use Copper Conductors Only". These instructions **must be** adhered to. Refer to the National Electrical Code (NEC) for complete current carrying capacity data on the various insulation grades of wiring material. All wiring must conform to NEC and all local codes.

The electrical data lists fuse and wire sizes (75° C copper) for all models including the most commonly used heater sizes. Also shown are the number of field power circuits required for the various models with heaters.

The unit rating plate lists a "Maximum Time Delay Relay Fuse" or "HACR" type circuit breaker that is to be used with the equipment. The correct size must be used for proper circuit protection and also to assure that there will be no nuisance tripping due to the momentary high starting current of the compressor motor.

The disconnect access door on this unit may be locked to prevent unauthorized access to the disconnect. To convert for the locking capability, bend the tab locate in the bottom left hand corner of the disconnect opening under the disconnect access panel straight out. This tab will now line up with the slot in the door. When shut a padlock may be placed through the hole in the tab preventing entry.

See "Start Up" section for important information on three phase scroll compressor start ups.

## WIRING – LOW VOLTAGE WIRING

230 / 208V, 1 phase and 3 phase equipment dual primary voltage transformers. All equipment leaves the factory wired on 240V tap. For 208V operation, reconnect from 240V to 208V tap. The acceptable operating voltage range for the 240 and 208V taps are:

TAP	RANGE
240	253 – 216
208	220 – 187

**NOTE:** The voltage should be measured at the field power connection point in the unit and while the unit is operating at full load (maximum amperage operating condition).

Nine (9) wires should be run from thermostat subbase to the 24V terminal board in the unit. A nine conductor, 18 gauge copper color-coded thermostat cable is recommended. The connection points are shown in Figure 8:

FIGURE 8

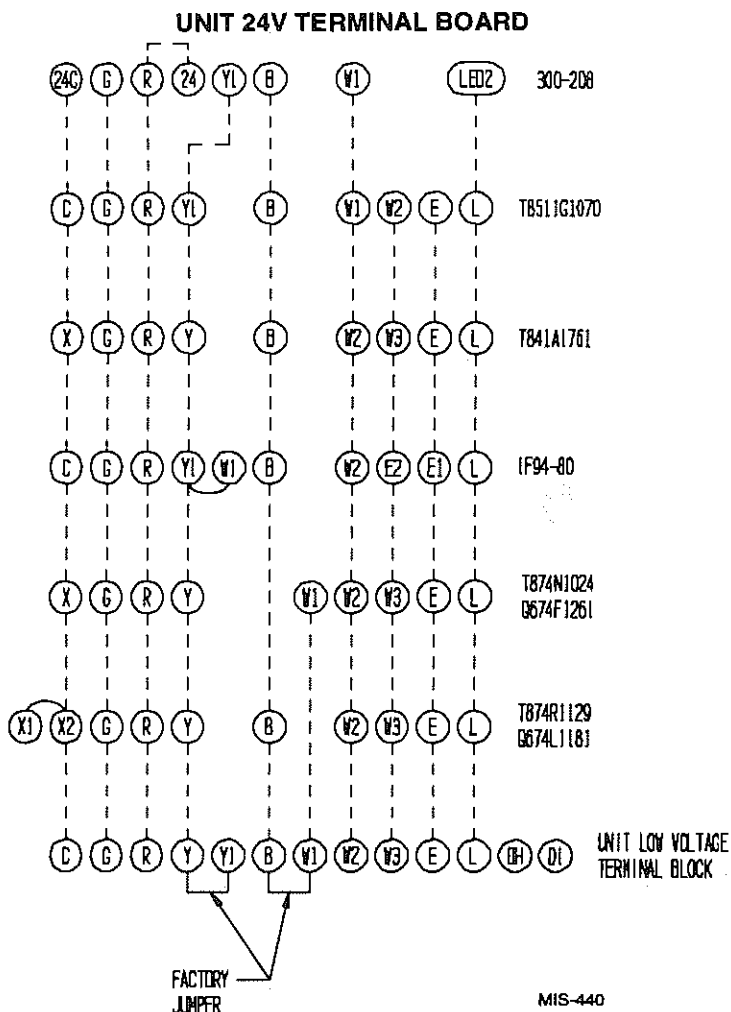

## IMPORTANT

Only the thermostat and subbase combinations as shown above will work with this equipment.

The thermostat and subbase **must be** matched, and the correct operation can be assured only by proper selection and application of these parts.

**TABLE 3  
THERMOSTAT WIRE SIZE**

Transformer VA	FLA	Wire Gauge	Maximum Distance In Feet
55	2.3	20 gauge	45
		18 gauge	60
		16 gauge	100
		14 gauge	160
		12 gauge	250

**FIGURE 9**  
**4 - 10KW 1 Ph - - 6 & 9KW 3 Ph**

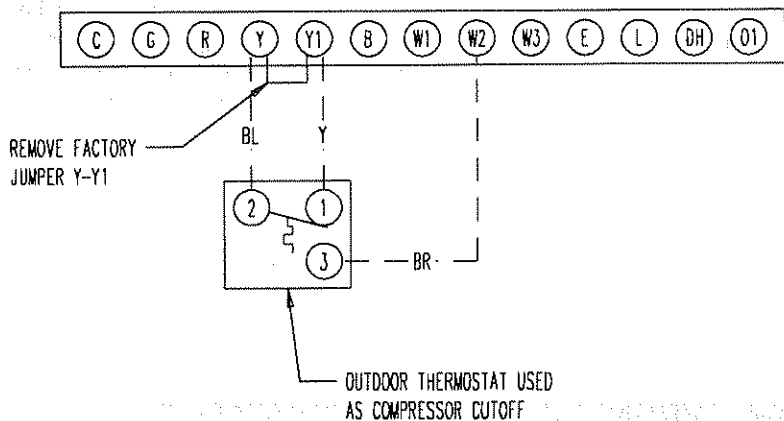

MIS-409

**FIGURE 10**  
**15 - 20KW 1 Ph and 3 Ph**

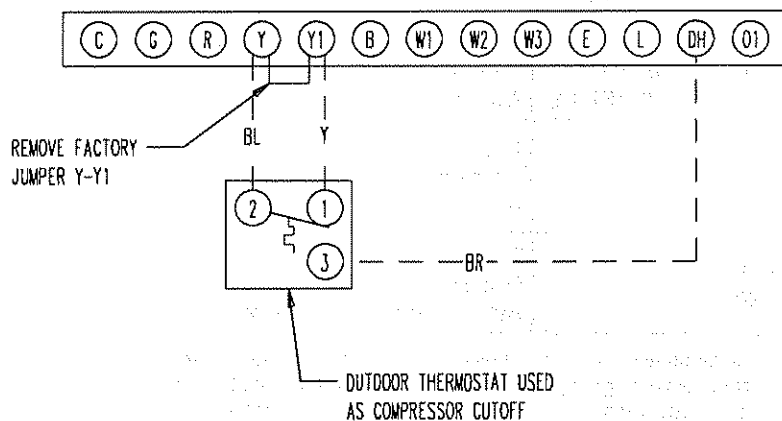

MIS-409

### COMPRESSOR CUT OFF THERMOSTAT AND OUTDOOR THERMOSTATS

Heat pump compressor operation at outdoor temperatures below 0° F are neither desirable nor advantageous in terms of efficiency. Since most equipment at time of manufacture is not designated for any specific destination of the country and most of the equipment is installed in areas not approaching the lower outdoor temperature range, the compressor cut offs are not factory installed.

Outdoor thermostats are available to hold off various banks of electric heat until needed as determined by outdoor temperature. The set point of either type of thermostat is variable with geographic region and sizing of the heating equipment to the structure. See Figures 9 and 10. Utilization of the Heating Application Data and the heat loss calculation of the building are useful in determining the correct set points.

### HEAT ANTICIPATION

All of the thermostats shown in Table 4 have a fixed heat anticipator for stage 1 with no adjustment required. Stage 2 has an adjustable anticipator of the W2 connection and fixed for the W3 connection. Both the W2 and W3 circuits are controlled by the stage 2 bulb. The only heat anticipator that needs to be checked is stage 2 and it should be set to match the load carried by the W2 circuit. The normal factory wiring provides for only one electric heat contactor to be controlled by W2, and the anticipator should be set at .40A. If special field wiring is done, it is best to actually measure the load but a good rule is .40A for *each* heat contactor controlled by W2.

### THERMOSTAT INDICATOR LAMPS

The red lamp marked "Em. Ht." comes on and stays on whenever the system switch is placed in the emergency heat position. The green lamp marked "check" will come on if there is any problem that prevents the compressor from running when it is supposed to be.

## EMERGENCY HEAT POSITION

The operator of the equipment must manually place the system switch in this position. This is done when there is a known problem with the unit, or when the green "check" lamp comes on indicating a problem.

## COMPRESSOR MALFUNCTION LIGHT

Actuation of the green "check" lamp is accomplished by a relay output from the heat pump control board which is factory installed. Any condition such as loss of charge, high head pressure, etc., that will prevent compressor from operating will cause the green lamp to activate. This is a signal to the operator of the equipment to place system in emergency heat position.

**TABLE 4**  
**WALL THERMOSTAT and SUBBASE COMBINATIONS**

Thermostat	Subbase	Predominant Features
8403-045 (T841A1761)	---	1 stg. cool; 2 stg. heat; Mercury bulb Manual changeover
8403-017 (T874R1129)	8404-009 (Q674L1181)	2 stg. cool; 2 stg. heat; Mercury bulb Manual changeover ①
8403-018 (T874N1024)	8404-010 (Q674F1261)	2 stg. cool; 2 stg. heat; Mercury bulb Auto or Manual changeover ②
8403-042 (T8511G107-0)	---	1 stg. cool; 2 stg. heat Electronic Non-Programmable Auto or Manual changeover
8403-034 (1F94-80)	---	2 stg. cool; 2 stg. heat Programmable Electronic Auto or Manual changeover

- ① No automatic changeover position – must manually place in heat or cool. Reversing valve remains energized at all times system switch is in heat position (except during defrost cycle). No pressure equalization noise when thermostat is satisfied on either heating or cooling.
- ② Allows thermostat to control both heating and cooling operation when set in "Auto" position. Reversing valve de-energizes at end of each "ON" heating cycle.

## IMPORTANT

Both thermostat and subbase combinations shown above incorporate the following features: Man – Auto fan switch, Off – Heat – Em. Heat switch, and two (2) indicator lamps; one for emergency heat and one for compressor malfunction.



# START UP

## IMPORTANT INSTALLER NOTE

For improved start up performance wash the indoor coil with a dish washing detergent.

## CRANKCASE HEATERS

WH491-B and -C are provided with compressor crankcase heat. All other models are not provided with crankcase heat. They are either single phase or the system refrigerant charge is not of sufficient quantity to require crankcase heat.

The WH491-B and -C models have a wrap around type heater located on the lower section of the compressor housing. This is an on/off heater that is controlled by the compressor contactor.

The label in Figure 11 is affixed to all WH491-B and -C units detailing start up procedure. This is *very* important. *Please read carefully.*

## HIGH PRESSURE SWITCH

All models are supplied with a remote reset high pressure switch. If tripped, this pressure switch may be reset by turning the thermostat off then back on again.

## TWO SPEED OUTDOOR FAN MOTORS

All units have two speed outdoor fan motors.

The two speed outdoor fan motor is controlled with an outdoor thermostat and operates on low speed below 80° F outdoor temperature in cooling mode. In heating mode it operates on high speed only.

## THREE PHASE SCROLL COMPRESSOR START UP INFORMATION

Scroll compressors, like several other types of compressors, will only compress in one rotational direction. Direction of rotation is not an issue with single phase compressors since they will always start and run in the proper direction.

However, three phase compressors will rotate in either direction depending upon phasing of the power. Since there is a 50-50 chance of connecting power in such a way as to cause rotation in the reverse direction, verification of proper rotation must be made. All three phase units incorporate a phase monitor to ensure proper field wiring. See the "Phase Monitor" section later in this manual.

Verification of *proper rotation* must be made any time a compressor is changed or rewired. If improper rotation is corrected at this time there will be no negative impact on the durability of the compressor. However, reverse operation for over one hour may have a negative impact on the bearing due to oil pump out.

**NOTE:** *If compressor is allowed to run in reverse rotation for several minutes, the compressor's internal protector will trip.*

FIGURE 11  
START UP LABEL

## IMPORTANT

THESE PROCEDURES MUST BE FOLLOWED AT INITIAL START UP AND AT ANY TIME POWER HAS BEEN REMOVED FOR 12 HOURS OR LONGER.

TO PREVENT COMPRESSOR DAMAGE WHICH MAY RESULT FROM THE PRESENCE OF LIQUID REFRIGERANT IN THE COMPRESSOR CRANKCASE:

1. MAKE CERTAIN THE ROOM THERMOSTAT IS IN THE "OFF" POSITION. (THE COMPRESSOR IS NOT TO OPERATE.)
2. APPLY POWER BY CLOSING THE SYSTEM DISCONNECT SWITCH. THIS ENERGIZES THE COMPRESSOR HEATER WHICH EVAPORATES THE LIQUID REFRIGERANT IN THE CRANKCASE.
3. ALLOW 4 HOURS OR 60 MINUTES PER POUND OF REFRIGERANT IN THE SYSTEM AS NOTED ON THE UNIT RATING PLATE, WHICHEVER IS GREATER.
4. AFTER PROPER ELAPSED TIME THE THERMOSTAT MAY BE SET TO OPERATE THE COMPRESSOR.
5. EXCEPT AS REQUIRED FOR SAFETY WHILE SERVICING, DO NOT OPEN SYSTEM DISCONNECT SWITCH.

7961-411

All three phase ZR3 compressors are wired identically internally. As a result, once the correct phasing is determined for a specific system or installation, connecting properly phased power leads to the same Fusite terminal should maintain proper rotation direction.

Verification of proper rotation direction is made by observing that suction pressure drops and discharge pressure rises when the compressor is energized. Reverse rotation also results in an elevated sound level over that with correct rotations, as well as, substantially reduced current draw compared to tabulate values.

The direction of rotation of the compressor may be changed by reversing any two line connections to the unit.

## PHASE MONITOR

All units with three phase compressors are equipped with a 3 phase line monitor to prevent compressor damage due to phase reversal.

The phase monitor in this unit is equipped with two LEDs. If the Y signal is present at the phase monitor and phases are correct, the green LED will light. If phases are reversed, the red fault LED will be lit and compressor operation is inhibited.

If a fault condition occurs, reverse two of the supply leads to the unit. Do not reverse any of the unit factory wires as damage may occur.

## SERVICE HINTS

1. Caution homeowner to maintain clean air filters at all times. Also, not to needlessly close off supply and return air registers. This reduces air flow through the system, which shortens equipment service life as well as increasing operating costs.
2. Switching to heating cycle at 75° F or higher outside temperature may cause a nuisance trip of the remote reset high pressure switch. Turn thermostat off then on to reset the high pressure switch.
3. The heat pump wall thermostats perform multiple functions. Be sure that all function switches are correctly set for the desired operating mode before trying to diagnose any reported service problems.
4. Check all power fuses or circuit breakers to be sure they are the correct rating.
5. Periodic cleaning of the outdoor coil to permit full and unrestricted airflow circulation is essential.

## SEQUENCE OF OPERATION

**COOLING** – Circuit R-Y makes at thermostat pulling in compressor contactor, starting the compressor and outdoor motor. The G (indoor motor) circuit is automatically completed on any call for cooling operation or can be energized by manual fan switch on subbase of constant air circulation.

**HEATING** – A 24V solenoid coil on reversing valve controls heating cycle operation. Two thermostat options, one allowing “Auto” changeover from cycle to cycle and the other constantly energizing solenoid coil during heating season and thus eliminating pressure equalization noise except during defrost, are to be used. On “Auto” option a circuit is completed from R-W1 and R-Y on each heating “on” cycle, energizing reversing valve solenoid and pulling in compressor contactor starting compressor and outdoor motor. R-G also make starting indoor blower motor. Heat pump heating cycle now in operation. The second option has no “Auto” changeover position, but instead energizes the reversing valve solenoid constantly whenever the system switch on subbase is placed in “Heat” position, the “B”

terminal being constantly energized from R. A thermostat demand for heat completes R-Y circuit, pulling in compressor contactor starting compressor and outdoor motor. R-G also make starting indoor blower motor.

## PRESSURE SERVICE PORTS

High and Low pressure service ports are installed on all units so that the system operating pressures can be observed. Pressure tables can be found later in the manual covering all models on both cooling and heating cycles. It is imperative to match the correct pressure table to the unit by model number.

## DEFROST CYCLE

The defrost cycle is controlled by temperature and time on the solid state heat pump control

When the outdoor temperature is in the lower 40° F temperature range or colder, the outdoor coil temperature is 32° F or below. This coil temperature is sensed by the coil sensor mounted near the bottom of the outdoor coil. Once coil temperature reaches 30° F or below, the coil sends a signal to the control logic of the heat pump control and the defrost timer will start.

After 60 (90 or 30) minutes at 30° F or below, the heat pump control will place the system in the defrost mode.

During the defrost mode, the refrigerant cycle switches back to the cooling cycle, the outdoor motor stops, electric heaters are energized, and hot gas passing through the outdoor coil melts any accumulated frost. When the temperature rises to approximately 57° F the coil sensor will send a signal to the heat pump control which will return the system to heating operations automatically.

If some abnormal or temporary condition such as a high wind causes the heat pump to have a prolonged defrost cycle, the heat pump control will restore the system to heating operation automatically after 10 minutes.

There are three settings on the heat pump control – 30 minutes, 60 minutes, and 90 minutes. Most models are shipped wired on the 60 minute setting for greatest operating economy. If special circumstances require a change to another time, remove wire connected to terminal 60 and reconnect to desired terminal.

There is a cycle speed up jumper on the control. This can be used to reduce the time between defrost cycle operation without waiting for time to elapse.

There is an initial defrost (INIT. DEF.) jumper on the control than can be used at any outdoor ambient during the heating cycle to simulate a 0° coil temperature. See Figure 12. This can be used to check defrost operation of the unit without waiting for the outdoor ambient to fall into the defrost region.

**FIGURE 12**  
**DEFROST CONTROL BOARD**

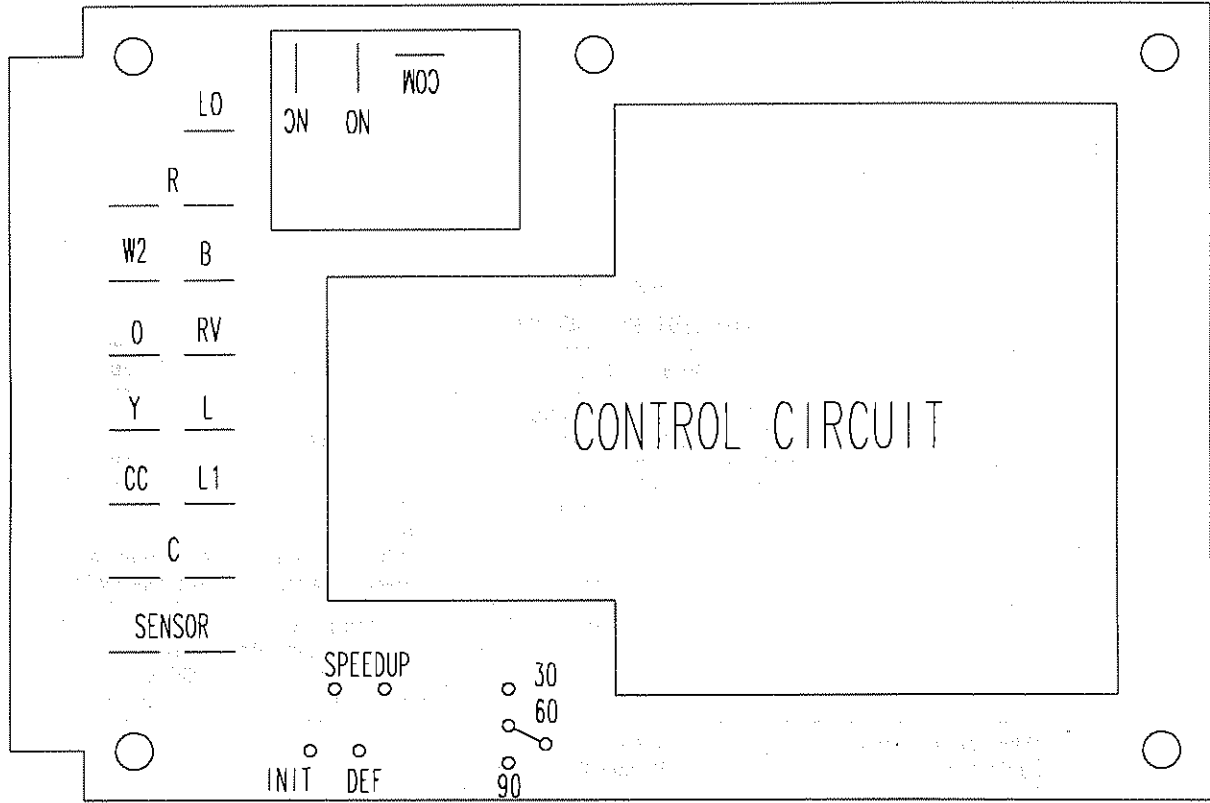

MIS-1174

# TROUBLESHOOTING

## SOLID STATE HEAT PUMP CONTROL TROUBLESHOOTING PROCEDURE

1. Turn on AC power supply to indoor and outdoor units.
2. Turn thermostat blower switch to fan on. The indoor blower should start. (If it doesn't, troubleshoot indoor unit and correct problem.)
3. Turn thermostat blower switch to auto position. Indoor blower should stop.

4. Set system switch to heat or cool. Adjust thermostat to call for heat or cool. The indoor blower, compressor, and outdoor fan should start.

*NOTE: If there was no power to 24 volt transformer, the compressor and outdoor fan motor will not start for 5 minutes. This is because of the compressor short cycle protection.*

**TABLE 5  
TROUBLESHOOTING**

SYMPTOM	POSSIBLE CAUSES	WHAT TO CHECK	HOW TO CHECK OR REPAIR
Compressor contactor does not energize (cooling or heating)	Control circuit wiring	Check for R connection at unit, and 24V between R-C	Run R connection to outdoor unit to power heat pump control
	Compressor lock out	1. Check for 24V between L1-C on heat pump control 2. Check across high pressure switch.	1. If no voltage between L-C turn thermostat off and on again to reset high pressure switch. 2. If high pressure switch is open and will not reset, replace high pressure switch.
	Compressor short cycle protection	Check for 24V between CC-C and Y-C on heat pump control	If no voltage between CC-C, jumper speed up terminal and within 10 seconds power should appear between CC-C. Remove speed up jumper after 10 seconds.
	Heat pump control defective	Check all other possible causes. Manual 2100-065	Replace heat pump control
	Contactors defective	Check for open or shorted coil winding.	Replace contactor
Fan outdoor motor does not run (cooling or heating except during defrost)	Motor defective	Check for open or shorted motor winding	Replace motor
	Motor capacitor defective	Check capacitor rating. Check for open or shorted capacitor.	Replace capacitor
	Heat pump control defective	Check across fan relay on heat pump control (Com-NC)	Replace heat pump control
Reversing valve does not energize (heating only)	Reversing valve solenoid coil defective	Check for open or shorted coil	Replace solenoid coil
	Heat pump control defective	Check for 24V between RV-C and B-C	1. Check control circuit wiring 2. Replace heat pump control
Unit will not go into defrost (heating only)	Temperature sensor or heat pump control defective	Disconnect temperature sensor from board and jumper across speed up terminals and sen jump terminals. This should cause the unit to go through a defrost cycle within one minute.	1. If unit goes through defrost cycle, replace temperature sensor 2. If unit does not go through defrost cycle, replace heat pump control
Unit will not come out of defrost (heating only)	Temperature sensor or heat pump control defective	Jumper across speed up terminals. This should cause the unit to come out of defrost within one minute.	1. If unit comes out of defrost cycle, replace temperature sensor. 2. If unit does not come out of defrost cycle, replace heat pump control.

**CHECKING TEMPERATURE SENSOR OUTSIDE UNIT CIRCUIT**

1. Disconnect temperature sensor from board and from outdoor coil.
2. Use an ohmmeter and measure the resistance of the sensor. Also use ohmmeter to check for short or open.
3. Check resistance reading to chart of resistance use sensor ambient temperature. (Tolerance of part is  $\pm 10\%$ )
4. If sensor resistance reads very low, then sensor is shorted and will not allow proper operation of the heat pump control.
5. If sensor is out of tolerance, shorted, open, or reads very low ohms then it should be replaced.

**TEMPERATURE F VS RESISTANCE R OF TEMPERATURE**

F	R	F	R	F	R
-25.0	196871	25.0	39898	75.0	10501
-24.0	190099	26.0	38757	76.0	10247
-23.0	183585	27.0	37652	77.0	10000
-22.0	177318	28.0	36583	78.0	9760
-21.0	171289	29.0	35548	79.0	9526
-20.0	165487	30.0	34545	80.0	9299
-19.0	159904	31.0	33574	81.0	9077
-18.0	154529	32.0	32634	82.0	8862
-17.0	149355	33.0	31723	83.0	8653
-16.0	144374	34.0	30840	84.0	8449
-15.0	139576	35.0	29986	85.0	8250
-14.0	134956	36.0	29157	86.0	8057
-13.0	130506	37.0	28355	87.0	7869
-12.0	126219	38.0	27577	88.0	7686
-11.0	122089	39.0	26823	89.0	7507
-10.0	118108	40.0	26092	90.0	7334
-9.0	114272	41.0	25383	91.0	7165
-8.0	110575	42.0	24696	92.0	7000
-7.0	107010	43.0	24030	93.0	6840
-6.0	103574	44.0	23384	94.0	6683
-5.0	100260	45.0	22758	95.0	6531
-4.0	97064	46.0	22150	96.0	6383
-3.0	93981	47.0	21561	97.0	6239
-2.0	91008	48.0	20989	98.0	6098
-1.0	88139	49.0	20435	99.0	5961
0.0	85371	50.0	19896	100.0	5827
1.0	82699	51.0	19374	101.0	5697
2.0	80121	52.0	18867	102.0	5570
3.0	77632	53.0	18375	103.0	5446
4.0	75230	54.0	17898	104.0	5326
5.0	72910	55.0	17434	105.0	5208
6.0	70670	56.0	16984	106.0	5094
7.0	68507	57.0	16547	107.0	4982
8.0	66418	58.0	16122	108.0	4873
9.0	64399	59.0	15710	109.0	4767
10.0	62449	60.0	15310	110.0	4663
11.0	60565	61.0	14921	111.0	4562
12.0	58745	62.0	14544	112.0	4464
13.0	56985	63.0	14177	113.0	4367
14.0	55284	64.0	13820	114.0	4274
15.0	53640	65.0	13474	115.0	4182
16.0	52051	66.0	13137	116.0	4093
17.0	50514	67.0	12810	117.0	4006
18.0	49028	68.0	12492	118.0	3921
19.0	47590	69.0	12183	119.0	3838
20.0	46200	70.0	11883	120.0	3757
21.0	44855	71.0	11591	121.0	3678
22.0	43554	72.0	11307	122.0	3601
23.0	42295	73.0	11031	123.0	3526
24.0	41077	74.0	10762	124.0	3452

## FAN BLADE SETTING DIMENSIONS

Shown in Figure 13 are the correct fan blade setting dimensions for proper air delivery across the outdoor coil.

Any service work requiring removal or adjustment in the fan and/or motor area will require that the dimensions below be checked and blade adjusted in or out on the motor shaft accordingly.

FIGURE 13

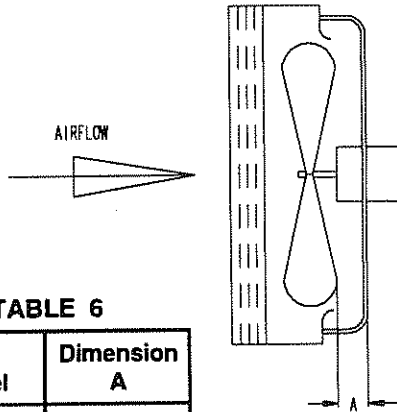

MIS-1272

TABLE 6

Model	Dimension A
WH381 WH431 WH491	1.00

## REMOVAL OF FAN SHROUD

1. Disconnect all power to the unit.
2. Remove the screws holding both grilles, one on each side of unit, and remove grilles.
3. Remove screws holding fan shroud to condenser and bottom. Nine (9) screws.

4. Unwire condenser fan motor.
5. Slide complete motor, fan blade, and shroud assembly out the left side of the unit.
6. Service motor/fan as needed.
7. Reverse steps to reinstall.

## REFRIGERANT CHARGE

The correct system R-22 charge is shown on the unit rating plate. Optimum unit performance will occur with a refrigerant charge resulting in a suction line temperature (6" from compressor) as shown in Table 7.

TABLE 7  
REFRIGERANT CHARGE

Model	Rated Airflow	95 OD Temperature	82 OD Temperature
WH381	1100	71 - 73	68 - 70
WH431	1300	72 - 75	69 - 71
WH491	1250	68 - 70	64 - 66

The suction line temperatures in Table 7 are based upon 80° F dry bulb / 67° F wet bulb (50% R.H.) temperature and rated airflow across the evaporator during cooling cycle.

TABLE 8  
RECOMMENDED OPERATING RANGES

Model	Rated CFM *	Rated ESP *	Recommended Airflow Range
WH381	1100	.15	1250 850
WH431	1300	.15	1475 850
WH491	1250	.20	1475 850

\* Rated CFM and ESP on high speed tap.

TABLE 9  
INDOOR BLOWER PERFORMANCE - CFM @ 230V / 460V

E.S.P. In H <sub>2</sub> O	WH381						WH431, WH491					
	High Speed		Medium Speed		Low Speed		High Speed		Medium Speed		Low Speed	
	Dry Coil	Wet Coil	Dry Coil	Wet Coil	Dry Coil	Wet Coil	Dry Coil	Wet Coil	Dry Coil	Wet Coil	Dry Coil	Wet Coil
.0	1625	1475	1425	1325	1125	1100	1700	1550	1475	1375	1200	1150
.1	1475	1350	1325	1200	1100	1000	1550	1400	1375	1250	1150	1050
.2	1350	1150	1200	1025	1000	850	1400	1250	1250	1100	1050	850
.3	1150	825	1025	875	825	675	1250	1100	1100	825		
.4	825	750					900	800				

Subtract .08 static for 2" filter

**NOTE:** WH431 and WH491 are shipped with the indoor blower on medium speed for free blow applications. Move to high speed for ducted applications.

**NOTE:** WH381 is shipped with the indoor blower on low speed for free blow applications. Move to medium speed for ducted applications.

**TABLE 10  
PRESSURE TABLE**

**COOLING**

Air Temperature Entering Outdoor Coil °F

Model	Return Air Temperature	Pressure	75	80	85	90	95	100	105	110	115
WH381	75 deg. DB 62 deg. WB	Low Side	77	78	79	80	81	82	84	85	85
		High Side	190	203	217	233	249	266	286	305	326
	80 deg. DB 67 deg. WB	Low Side	82	83	85	86	87	88	90	91	91
		High Side	195	208	223	239	255	273	293	313	334
	85 deg. DB 72 deg. WB	Low Side	85	86	88	89	90	91	93	94	94
		High Side	202	215	231	247	264	283	303	324	346
WH431	75 deg. DB 62 deg. WB	Low Side	74	74	75	76	77	78	79	81	83
		High Side	194	209	224	240	257	275	293	312	332
	80 deg. DB 67 deg. WB	Low Side	79	79	80	81	82	83	85	87	89
		High Side	199	214	230	246	264	282	300	320	340
	85 deg. DB 72 deg. WB	Low Side	82	82	83	84	85	86	88	90	92
		High Side	206	221	238	255	273	292	311	331	352
WH491	75 deg. DB 62 deg. WB	Low Side	72	72	72	73	74	75	77	79	80
		High Side	198	213	228	244	260	278	296	316	335
	80 deg. DB 67 deg. WB	Low Side	77	77	77	78	79	80	82	84	86
		High Side	203	218	234	250	267	285	304	324	344
	85 deg. DB 72 deg. WB	Low Side	80	80	80	81	82	83	85	87	89
		High Side	210	226	242	259	276	295	315	335	356

**TABLE 11  
PRESSURE TABLE**

**HEATING**

Air Temperature Entering Outdoor Coil °F

Model	Return Air Temperature	Pressure	0	5	10	15	20	25	30	35	40	45	50	55	60
WH381	70 deg.	Low Side	15	19	24	28	33	37	42	46	51	56	60	65	70
		High Side	156	161	167	173	179	185	192	198	205	212	219	227	234
WH431	70 deg.	Low Side	17	20	23	27	30	34	39	43	48	53	58	63	69
		High Side	162	164	167	170	175	180	185	192	199	207	216	226	236
WH491	70 deg.	Low Side	15	19	23	27	32	36	41	45	50	54	59	64	69
		High Side	135	155	174	191	206	218	229	237	243	247	249	252	255

Low side pressure ± 2 PSIG

High side pressure ± 5 PSIG

Tables are based upon rated CFM (airflow) across the evaporator coil. If there is any doubt as to correct operating charge being in the system, the charge should be removed, system evacuated and recharged to serial plate instruction.









460-60-3

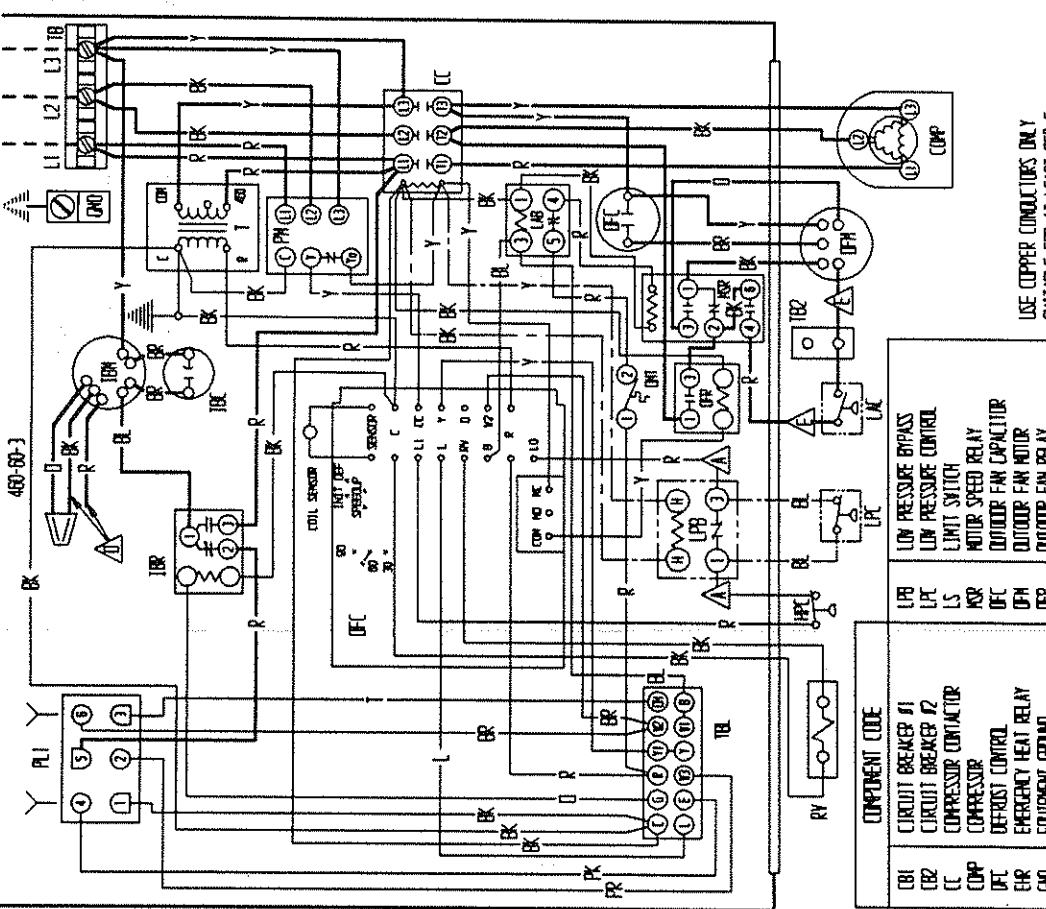
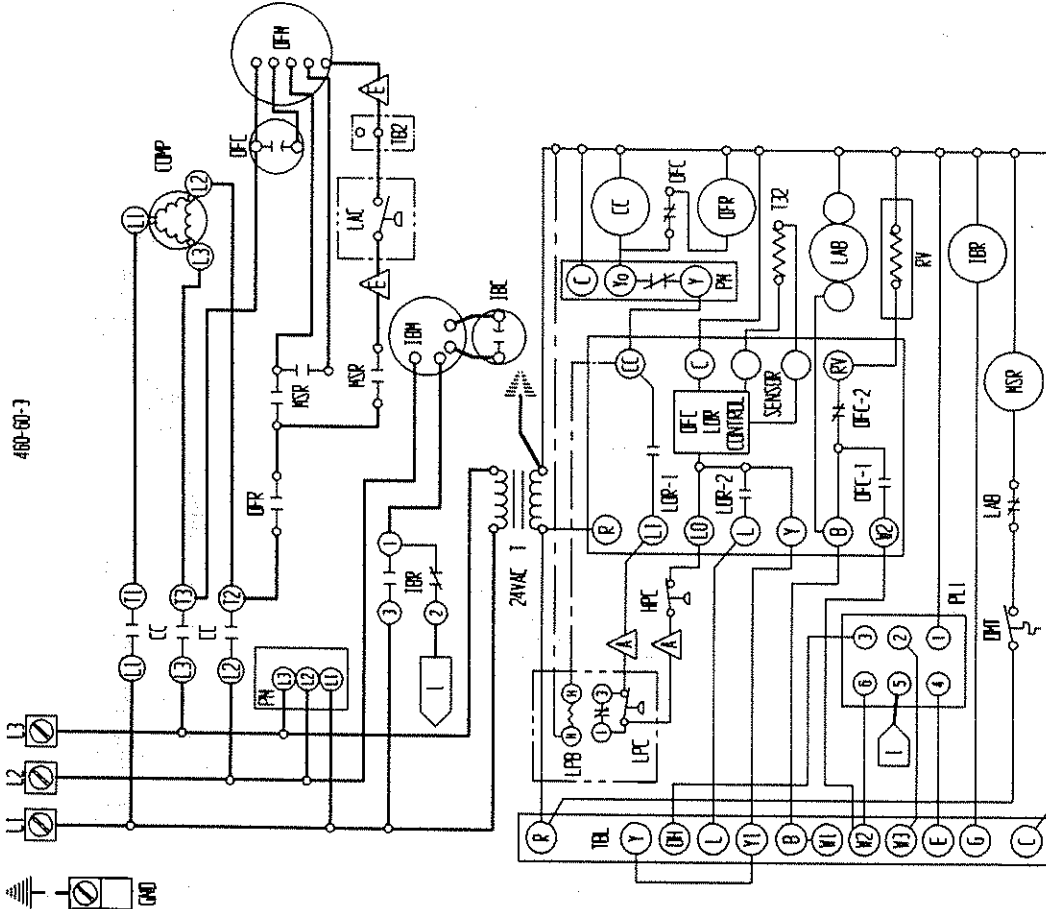

460-60-3

USE COPPER CONDUCTORS ONLY  
SUITABLE FOR AT LEAST 75° C

▲ Labeled wires connect orange to black, red (low) or blue (medium) to T1 of IBR.  
▲ If no options used, red, blue leads separately, connect black to T1 of IBR.

FACTORY STD. FIELD OPTIONAL

HIGH VOLTAGE  
LOW VOLTAGE  
ACCESSORY

COMPONENT CODE	DESCRIPTION
CB1	CIRCUIT BREAKER #1
CB2	CIRCUIT BREAKER #2
CC	COMPRESSOR CONTACTOR
DFC	DEFROST CONTROL
EMR	EMERGENCY HEAT RELAY
EQ	EQUIPMENT GROUND
HS	HEAT STRIP #1
HC1	HEATER CONTACTOR #1
HPC	HIGH PRESSURE CONTROL
IBR	INDOOR BLOWER MOTOR
IBR	INDOOR BLOWER RELAY
LAB	LOW AMBIENT BYPASS
LAC	LOW AMBIENT CONTROL
LB1	LOW PRESSURE BYPASS
LPC	LOW PRESSURE CONTROL
LS	LIMIT SWITCH
MSR	MOTOR SPEED RELAY
DFC	OUTDOOR FAN CAPACITOR
DFM	OUTDOOR FAN MOTOR
DFM	OUTDOOR FAN RELAY
DMT	OUTDOOR MOTOR THERMOSTAT
PL1	PLUG #1
PM	PHASE MONITOR
RV	REV. VALVE SOLINOID
T	TRANSFORMER
TB, TB2	TERMINAL BLOCK
TB	LOW VOLTAGE TERMINAL BLOCK
TCO	THERMAL CUTOFF

BARD MFG. CO.  
4096-316

COLOR CODE	
Y	YELLOW
G	GREEN
B	BLUE
W	WHITE
V	VIOLET
P	PURPLE
GR	GRAY
S	SLATE
T	TAN
PK	PINK
L	LAVENDER

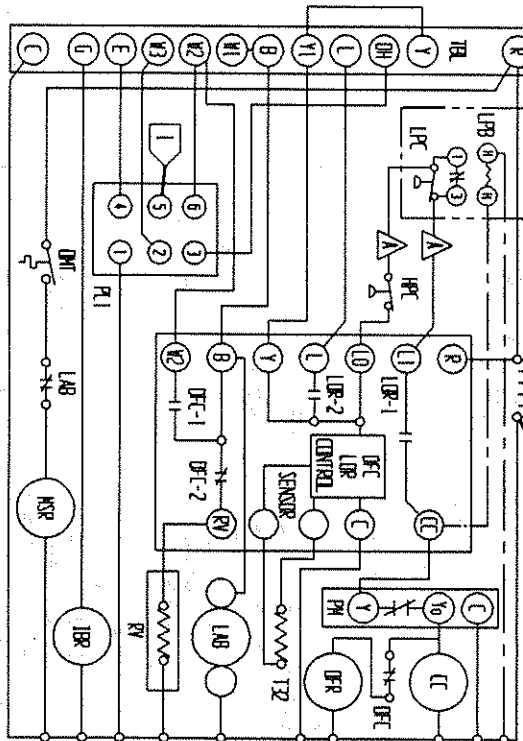
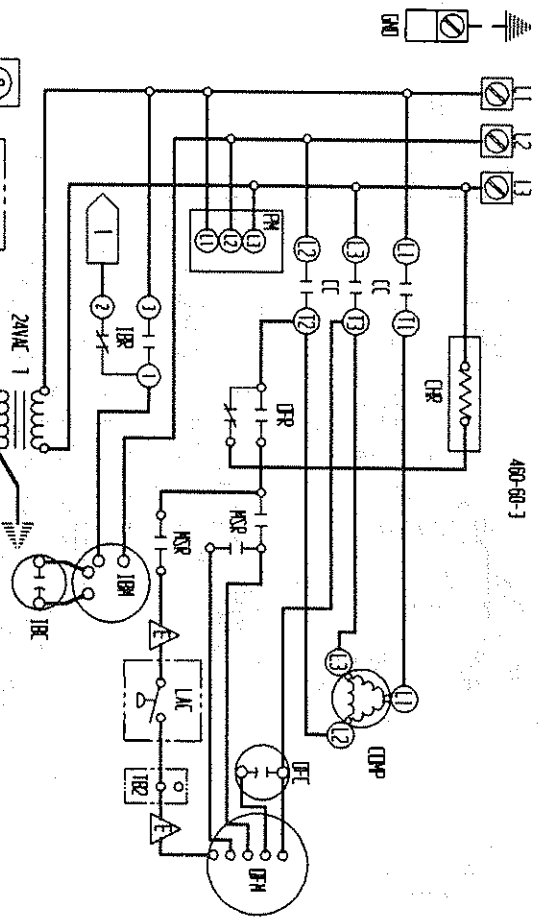
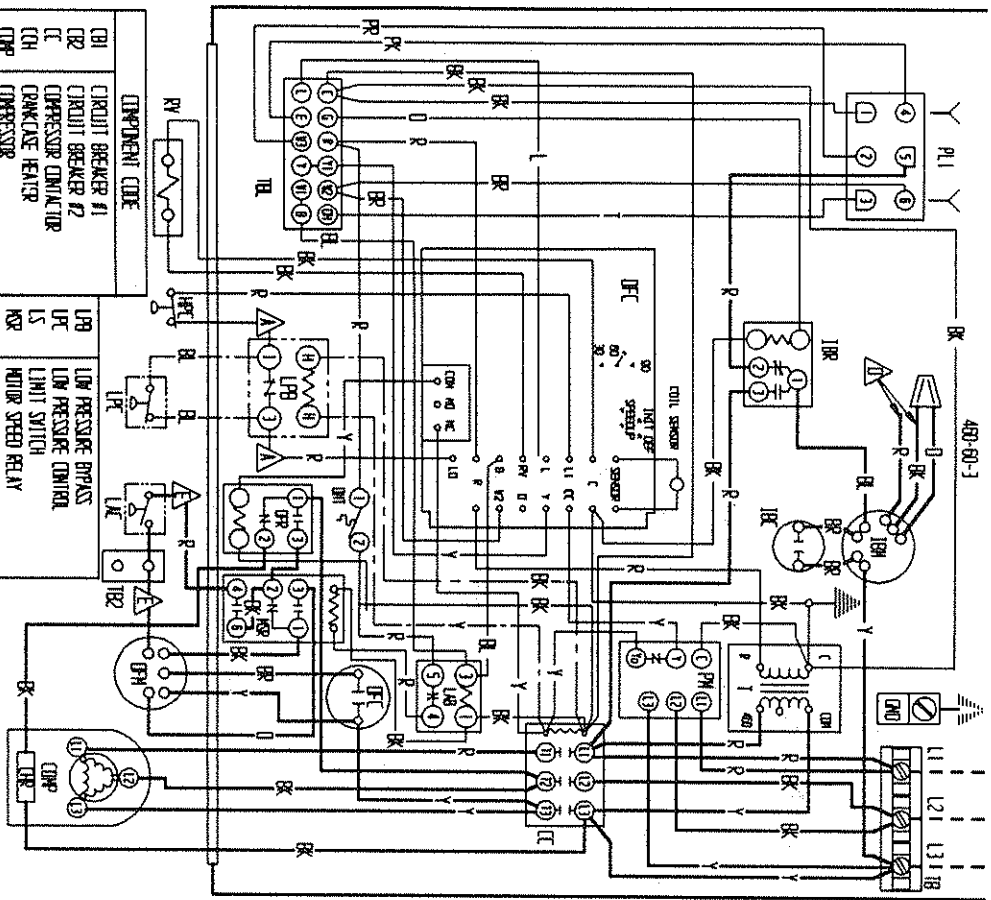

COMPONENT CODE	DESCRIPTION
CB1	CIRCUIT BREAKER #1
CB2	CIRCUIT BREAKER #2
CC	COMPRESSOR CONTACTOR
CH	CONDENSATE HEATER
COMP	COMPRESSOR
DCP	DEFROST CONTROL
EH	EMERGENCY HEAT RELAY
EQ	EQUIPMENT GROUND
HS	HEAT STRIP #1
H1	HEATER CONTACTOR #1
H2	HEATER CONTACTOR #2
IB	INDOOR BLOWER MOTOR
IB1	INDOOR BLOWER MOTOR
IB2	INDOOR BLOWER MOTOR
IB3	INDOOR BLOWER MOTOR
IB4	INDOOR BLOWER MOTOR
IB5	INDOOR BLOWER MOTOR
IB6	INDOOR BLOWER MOTOR
IB7	INDOOR BLOWER MOTOR
IB8	INDOOR BLOWER MOTOR
IB9	INDOOR BLOWER MOTOR
IB10	INDOOR BLOWER MOTOR
IB11	INDOOR BLOWER MOTOR
IB12	INDOOR BLOWER MOTOR
IB13	INDOOR BLOWER MOTOR
IB14	INDOOR BLOWER MOTOR
IB15	INDOOR BLOWER MOTOR
IB16	INDOOR BLOWER MOTOR
IB17	INDOOR BLOWER MOTOR
IB18	INDOOR BLOWER MOTOR
IB19	INDOOR BLOWER MOTOR
IB20	INDOOR BLOWER MOTOR
IB21	INDOOR BLOWER MOTOR
IB22	INDOOR BLOWER MOTOR
IB23	INDOOR BLOWER MOTOR
IB24	INDOOR BLOWER MOTOR
IB25	INDOOR BLOWER MOTOR
IB26	INDOOR BLOWER MOTOR
IB27	INDOOR BLOWER MOTOR
IB28	INDOOR BLOWER MOTOR
IB29	INDOOR BLOWER MOTOR
IB30	INDOOR BLOWER MOTOR
IB31	INDOOR BLOWER MOTOR
IB32	INDOOR BLOWER MOTOR
IB33	INDOOR BLOWER MOTOR
IB34	INDOOR BLOWER MOTOR
IB35	INDOOR BLOWER MOTOR
IB36	INDOOR BLOWER MOTOR
IB37	INDOOR BLOWER MOTOR
IB38	INDOOR BLOWER MOTOR
IB39	INDOOR BLOWER MOTOR
IB40	INDOOR BLOWER MOTOR
IB41	INDOOR BLOWER MOTOR
IB42	INDOOR BLOWER MOTOR
IB43	INDOOR BLOWER MOTOR
IB44	INDOOR BLOWER MOTOR
IB45	INDOOR BLOWER MOTOR
IB46	INDOOR BLOWER MOTOR
IB47	INDOOR BLOWER MOTOR
IB48	INDOOR BLOWER MOTOR
IB49	INDOOR BLOWER MOTOR
IB50	INDOOR BLOWER MOTOR
IB51	INDOOR BLOWER MOTOR
IB52	INDOOR BLOWER MOTOR
IB53	INDOOR BLOWER MOTOR
IB54	INDOOR BLOWER MOTOR
IB55	INDOOR BLOWER MOTOR
IB56	INDOOR BLOWER MOTOR
IB57	INDOOR BLOWER MOTOR
IB58	INDOOR BLOWER MOTOR
IB59	INDOOR BLOWER MOTOR
IB60	INDOOR BLOWER MOTOR
IB61	INDOOR BLOWER MOTOR
IB62	INDOOR BLOWER MOTOR
IB63	INDOOR BLOWER MOTOR
IB64	INDOOR BLOWER MOTOR
IB65	INDOOR BLOWER MOTOR
IB66	INDOOR BLOWER MOTOR
IB67	INDOOR BLOWER MOTOR
IB68	INDOOR BLOWER MOTOR
IB69	INDOOR BLOWER MOTOR
IB70	INDOOR BLOWER MOTOR
IB71	INDOOR BLOWER MOTOR
IB72	INDOOR BLOWER MOTOR
IB73	INDOOR BLOWER MOTOR
IB74	INDOOR BLOWER MOTOR
IB75	INDOOR BLOWER MOTOR
IB76	INDOOR BLOWER MOTOR
IB77	INDOOR BLOWER MOTOR
IB78	INDOOR BLOWER MOTOR
IB79	INDOOR BLOWER MOTOR
IB80	INDOOR BLOWER MOTOR
IB81	INDOOR BLOWER MOTOR
IB82	INDOOR BLOWER MOTOR
IB83	INDOOR BLOWER MOTOR
IB84	INDOOR BLOWER MOTOR
IB85	INDOOR BLOWER MOTOR
IB86	INDOOR BLOWER MOTOR
IB87	INDOOR BLOWER MOTOR
IB88	INDOOR BLOWER MOTOR
IB89	INDOOR BLOWER MOTOR
IB90	INDOOR BLOWER MOTOR
IB91	INDOOR BLOWER MOTOR
IB92	INDOOR BLOWER MOTOR
IB93	INDOOR BLOWER MOTOR
IB94	INDOOR BLOWER MOTOR
IB95	INDOOR BLOWER MOTOR
IB96	INDOOR BLOWER MOTOR
IB97	INDOOR BLOWER MOTOR
IB98	INDOOR BLOWER MOTOR
IB99	INDOOR BLOWER MOTOR
IB100	INDOOR BLOWER MOTOR

USE COPPER CONDUCTORS ONLY  
SUITABLE FOR AT LEAST 75° C

UNLEADED WIRES CONNECT FOR LOW & MEDIUM SPEEDS CONNECT ORANGE TO BLACK, RED (LOW) OR BLUE (MEDIUM) TO 11 OF IBR.  
IF NO OPTIONS USED, FOR HIGH SPEED TAPE DRIVE, RED, BLUE LEADS SEPARATELY, CONNECT BLACK TO 11 OF IBR.

FACTORY SIG.	FIELD	OPTIONAL
HIGH VOLTAGE	---	---
LOW VOLTAGE	---	---
ACCESSORY	---	---

COLOR CODE		BARD WFC. CO.	
BK	BLACK	Y	YELLOW
BR	BROWN	G	GREEN
R	RED	B	BLUE
D	ORANGE	W	WHITE
		V	VIOLET
		(GR)	GREEN
		GR	GRAY
		(S)	SLATE
		T	TAN
		PK	PINK
		L	LAVENDER

4096-317