INSTALLATION INSTRUCTIONS

SINGLE PACKAGE AIR CONDITIONERS

MODELS
P1242A1
P1248A1



CLIMATE CONTROL SOLUTIONS

Bard Manufacturing Company
Bryan, Ohio 43506

Since 1914 . . . Moving ahead just as planned

Manual : 2100-353B
Supersedes: 2100-353A
File: Volume II Tab 10
Date: 04-01-02

Contents

Getting Other Informations and Publications	1	Thermostats	9
General Instructions		Start Up and Operation	
Important	2	Three Phase Scroll Compressor Start Up	
Shipping Damage	2	Information	11
General	2	Sequence of Operation	11
Field Installed Heater Packages (Optional)	3	Start Up Notes	11
Installation		Indoor Blower Motor	11
Location	5	Compressor Control Module	11
Duct Work	5	Adjustments	12
Typical Installations	5	Service and Troubleshooting	
Condensate Drain Trap	8	Service Hints	13
Air Filters	8	Pressure Service Ports	13
Wiring – Main Power	9	Refrigerant Charge	13
Wiring – 24V Low Voltage Control Circuit	9	Fan Blade Settings	13
Transformer Taps	9	Suction and Discharge Tube Brazing	13
		Pressure Table	14
		Wiring Diagrams	15-16
Figures		Tables	
Figure 1 Prefabricated Rood Curb		Table 1 Electrical Data	2
Specifications	4	Table 2 Option Field Installed Heater Packages .	3
Figure 2 Field Fabricated Curbing	4	Table 3 Electric Heater Table	3
Figure3 Elevated Mounting Platforms	6	Table 4 Rated CFM and Rated ESP	5
Figure 4 Airflow and Service Access		Table 5 Air Filter Area and Size	8
Clearances	6	Table 6 Thermostat Wire Size	9
Figure 5 Roof Top Application	7	Table 7 Wall Thermostat and Subbase	
Figure 6 Slab Mounting at Ground Level	7	Combinations	9
Figure 7 Condensate Drain Trap	8	Table 8 Refrigerant Charge	13
Figure 8 Low Voltage Wiring	10	Table 9 Pressure Table	14
Figure 9 Fan Blade Setting Dimensions	13		
Figure 10 Brazing Diagram	14		

Getting Other Information and Publications

These publications can help you install the air conditioner or heat pump. You can usually find these at your local library or purchase them directly from the publisher. Be sure to consult current edition of each standard.

National Electrical Code ANSI/NFPA 70

Standard for the Installation ANSI/NFPA 90A
of Air Conditioning and
Ventilating Systems

Standard for Warm Air ANSI/NFPA 90B
Heating and Air
Conditioning Systems

Load Calculation for ACCA Manual J

Residential Winter and
Summer Air Conditioning

Duct Design for Residential ACCA Manual D
Winter and Summer Air
Conditioning and Equipment Selection

FOR MORE INFORMATION, CONTACT THESE PUBLISHERS:

ACCA **Air Conditioning Contractors of America**
1712 New Hampshire Ave. N.W.
Washington, DC 20009
Telephone: (202) 483-9370
Fax: (202) 234-4721

ANSI **American National Standards Institute**
11 West Street, 13th Floor
New York, NY 10036
Telephone: (212) 642-4900
Fax: (212) 302-1286

ASHRAE **American Society of Heating, Refrigerating,
and Air Conditioning Engineers, Inc.**
1791 Tullie Circle, N.E.
Atlanta, GA 30329-2305
Telephone: (404) 636-8400
Fax: (404) 321-5478

NFPA **National Fire Protection Association**
Batterymarch Park
P.O. Box 9101
Quincy, MA 02269-9901
Telephone: (800) 344-3555
Fax: (617) 984-7057

GENERAL INSTRUCTIONS

IMPORTANT

The equipment covered in this manual is to be installed by trained, experienced service and installation technicians. All duct work, supply and return ducts, must be properly sized for the design air flow requirement of the equipment. ACCA is an excellent guide to proper sizing. All duct work or portions thereof not in the conditioned space should be properly insulated in order to both conserve energy and prevent condensation or moisture damage.

SHIPPING DAMAGE

Upon receipt of equipment, the carton should be checked for external signs of shipping damage. If damage is found, the receiving party must contact the last carrier immediately, preferably in writing, requesting inspection by the carrier's agent.

GENERAL

The refrigerant system is completely assembled and charged. All internal wiring is complete.

The unit is designed for use with or without duct work. Flanges are provided for attaching the supply and return ducts.

These instructions explain the recommended method to install the air cooled self-contained unit and the electrical wiring connections to the unit.

These instructions and any instructions packaged with any separate equipment required to make up the entire heat pump system should be carefully read before beginning the installation. Note particularly "Starting Procedure" and any tags and/or labels attached to the equipment.

While these instructions are intended as a general recommended guide, they do not supersede any national and/or local codes in any way. Authorities having jurisdiction should be consulted before the installation is made.

**TABLE 1
ELECTRICAL DATA**

Model	Rated Volts & Phases	Operating Voltage Range	Maximum Unit Amps	①	Minimum Circuit Ampacity	②	②
				Maximum External Fuses or Ckt. Brk. Ckt. A		Field Power Wiring Ckt. A	Ground Wire Size Ckt. A
P1242A1	230/208-1	197 - 253	24.1	45	30	8	10
P1248A1	230/208-1	197 - 253	28.3	60	37	8	10
P1248A1-B	230/208-1	187 - 253	19.1	35	24	8	10

① Maximum time delay fuse or HACR type circuit breaker.

② 75 degree C copper wire size, basic unit only.

FIELD INSTALLED HEATER PACKAGES (OPTIONAL)

These packaged air conditions are manufactured without supplementary electric heaters. Supplementary heaters, EH5PB series, are available for simple, fast field installation.

A separate power circuit is required for the supplementary heaters.

IMPORTANT: Refer to Tables 2 and 4 when designing duct work for maximum available static pressure with heater installed.

Refer to electrical data shown on pages 2 and 3 for proper application information on all available heater combinations and what units they can be used with. It also shows the applicable circuit ampacities, fuse size, and wire size for each heater combination.

**TABLE 2
OPTIONAL FIELD INSTALLED HEATER PACKAGES
ONLY TO BE USED WITH THE HEAT PUMP MODELS INDICATED**

Heater Package Model No.	Volts and Phases	P1242A1	P1248A1	P1248A1-B
EH5PB-A05 EH5PB-A10 EH5PB-A15	240/1	S S S	S S S	A A A
EH5PB-B09 EH5PB-B15	240/3	A A	A A	S S

S = Standard Application – Heater volts and phase same as basic unit

A = Alternate application – Heater volts and phase different from basic unit.

**TABLE 3
OPTIONAL FIELD INSTALLED ELECTRIC HEATER TABLE**

Heater Pkg. Model No.	Unit Volts Phases	Htr. KW & Capacity @ 240 Volts		Htr. KW & Capacity @ 208 Volts		240V Htr. Amps	Heater Internal Fuses	Circuit B				
		KW	BTUH	KW	BTUH			No. Field Circuits	Min. Circuit Ampacity	① Max. Over-Current Protection	② Field Power Wiring	③ Ground Wire Size
EH5PB-A05	240/208-1	5	17,100	3.05	12,800	20.8		1	26	30	10	10
EH5PB-A10	240/208-1	10	34,100	7.5	26,000	41.7		1	53	60	6	10
EH5PB-A15	240/208-1	15	51,200	11.25	38,400	62.5	30/60	1	79	80	4	8
EH5PB-B09	240/208-3	9	30,700	6.75	23,000	21.7		1	28	30	10	10
EH5PB-B15	240/208-3	15	51,200	11.25	38,400	36.2		1	50	50	8	10

① Time Delay fuses of "HACR" type circuit breakers must be used for 60 and smaller sizes. Standard fuses or circuit breakers are suitable for sizes 70 and larger. 480V circuit breakers are not "HACR" type.

② Based on wire suitable for 75 degree C. Other wiring materials must be rated for marked "Minimum Circuit Ampacity" or greater.

③ Based upon Table 250-95 of N.E.C. 1993. See electric data for basic heat pump for Circuit A wiring specification requirements.

IMPORTANT: While this electrical data is presented as a guide, it is important to electrically connect properly sized fuses and conductor wires in accordance with the National Electrical Code and all existing local codes.

**FIGURE 1
 PREFABRICATED ROOF CURB SPECIFICATIONS
 HEAVY GAUGE GALVANIZED WITH WOOD NAILING STRIP, WELDED/LEAKPROOF
 ONE PIECE CONSTRUCTION – READY TO INSTALL**

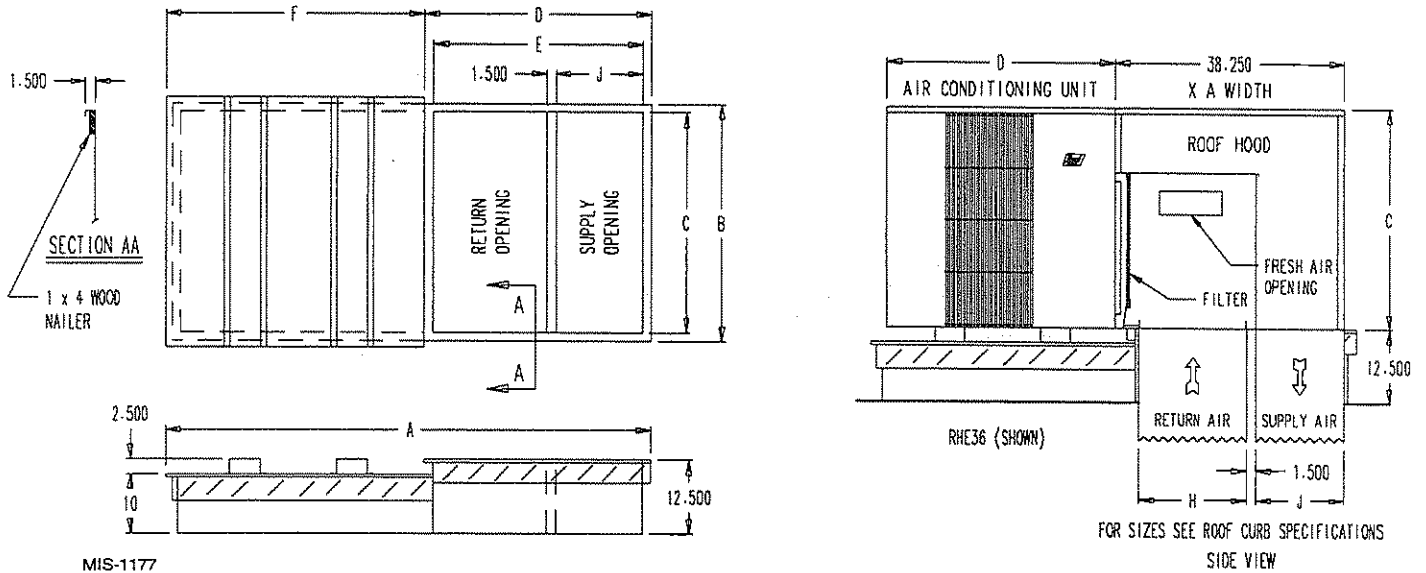

MIS-1177

CURB AND ROOF DETAILS

Roof Curb	A	B	C*	D	E	F	J*	H*	Roof Hood Model	Air Conditioning Units
9042-004	82-3/8	44-1/8	41-1/8	38-3/8	35-3/8	44	14-3/4	19-1/8	RHE60	P1242A1, P1248A1

*Duct Sizing Information

Return Air Dimension "C" is length
 Return Air Dimension "H" is width

Supply Air Dimension "C" is length
 Supply Air Dimension "J" is width

**FIGURE 2
 FIELD FABRICATED CURBING**

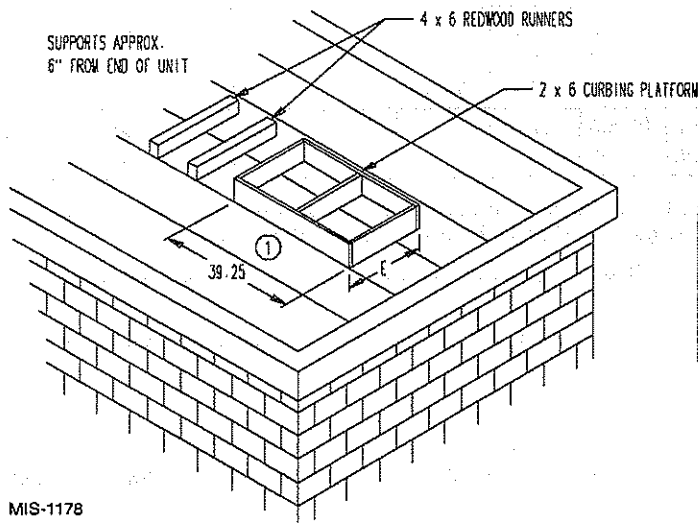

MIS-1178

Roof Hood Model	Unit Model	E
RHE60	P1242A1 P1248A1	44-7/8

① A SEPARATE METAL FLASHING SHOULD BE INSTALLED AROUND WOOD CURBING. CAULK & SEAL ALL JOINTS & WEATHERPROOF.

LOCATION

GENERAL

The unit must be located outside, or in a well ventilated area. It must not be in the space being heated or cooled. A sound absorbing material should be considered if the unit is to be installed in such a position or location that might cause transmission of sound or vibration to the living area or adjacent buildings.

SLAB MOUNTING

In areas where winter temperatures *DO NOT* go below 32° F for periods over twelve hours, the unit may be slab mounted at grade level. When installing unit at grade level, install on a concrete slab at least four inches above finished grade level. Slab should have a slope tolerance away from the building structure of at least 1/4 inch per foot, while being level from side to side. Place slab in a location where runoff water from higher ground will not collect around unit. See Figure 3.

A minimum of 18 inches should be provided between the coil inlet and any building surfaces. Provide at least four feet between coil outlet and any building wall, fences or other vertical structures. Provide a minimum of three feet clearance on the service access side of the unit. See Figure 4

ROOF MOUNTING

When a unit is installed in areas where low ambient temperatures or strong winter winds exist, it should be placed for prevailing winter winds are not in direct line with the outdoor coil. If this is not possible, a wind barrier should be constructed. Place barrier 24 inches from the coil inlet side of the unit and in the direction of prevailing winds. Size barrier at least the same height and width as the unit. This may be necessary on ground level installations, also. See Figure 5.

WINTER INSTALLATION BELOW 32°F

In areas where winter conditions go below 32°F for extended periods, the unit must be elevated above the mounting surface to prevent snowfall or ice accumulation from interfering with the operation of the unit. A minimum of twelve inch elevation is recommended, while greater elevation may be required for areas of high snow accumulation. Poured concrete, steel framework, brick, cement block, etc., can be utilized to construct a suitable raised mounting platform. See Figure 6.

DUCT WORK

Refer to Tables 4 when designing duct work for maximum static pressure available with the specific model and heater package being installed.

TABLE 4
RATED CFM AND
EXTERNAL STATIC PRESSURE (ESP)

Model	Rated CFM	① Maximum ESP
P1242A1	1400	.50
P1248A1	1550	.50

① Motor will adjust to deliver rated airflow.

TYPICAL INSTALLATIONS

- 1. ROOF MOUNTED** – The unit is mounted on a sturdy base on the roof of the building. Return air to the unit is brought through a single return grille (grilles with built-in filters are best since they enable easy access for filter changing). Return air ducts are attached to the lower section of the front panel. Supply air is brought from the unit to attic duct work or to a furred down hall. Supply air duct is attached to the top of the front panel.

CAUTION: All outdoor duct work must be thoroughly insulated and weatherproofed. All attic duct work must be thoroughly insulated. Two inch thick insulation with suitable vapor barrier is recommended for both outdoor and attic runs.

In roof top installation, as in all installations, the air conditioner must be level from side to side. However, the unit should have a pitch along the length to assure complete external drainage of precipitation and of defrost condensate.

- 2. CRAWL SPACE** – Duct work installed in crawl space must be well insulated and provided with a vapor barrier. In addition, the crawl space must be thoroughly ventilated and provided with a good vapor barrier as a ground cover. It is most desirable to install the unit will be outdoors rather than inside the crawl space, so that it will be readily accessible for service.

**FIGURE 3
ELEVATED MOUNTING PLATFORMS**

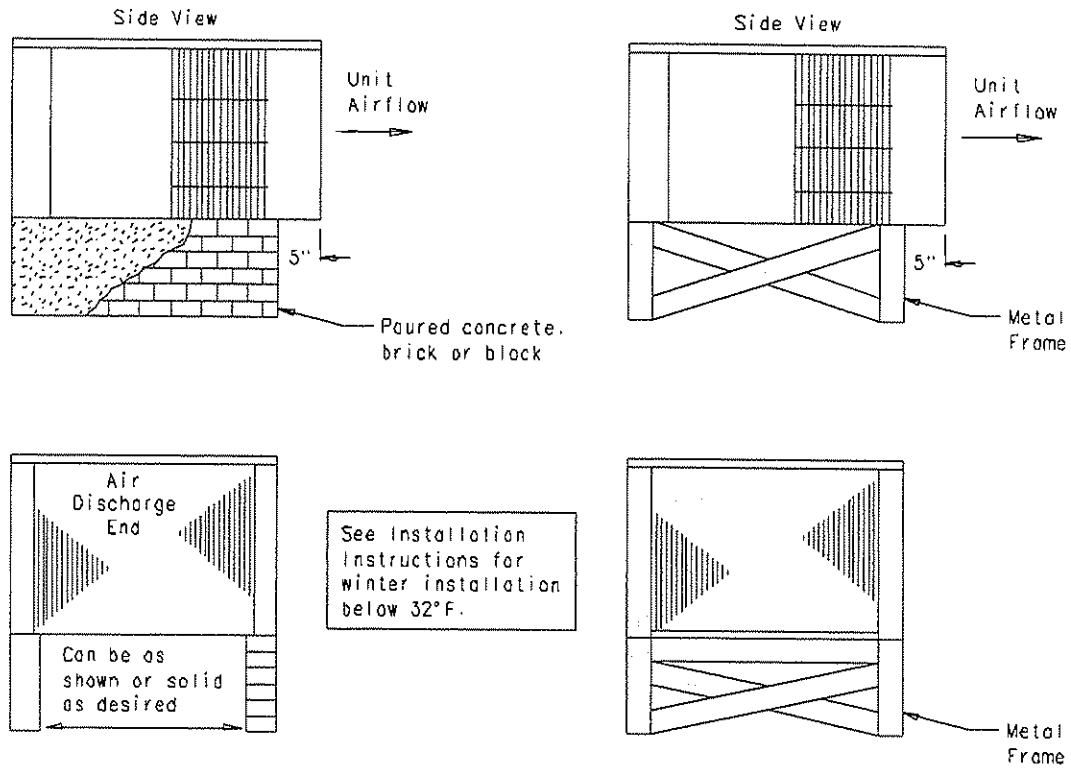

MIS-1183

**FIGURE 4
AIRFLOW AND SERVICE ACCESS CLEARANCES**

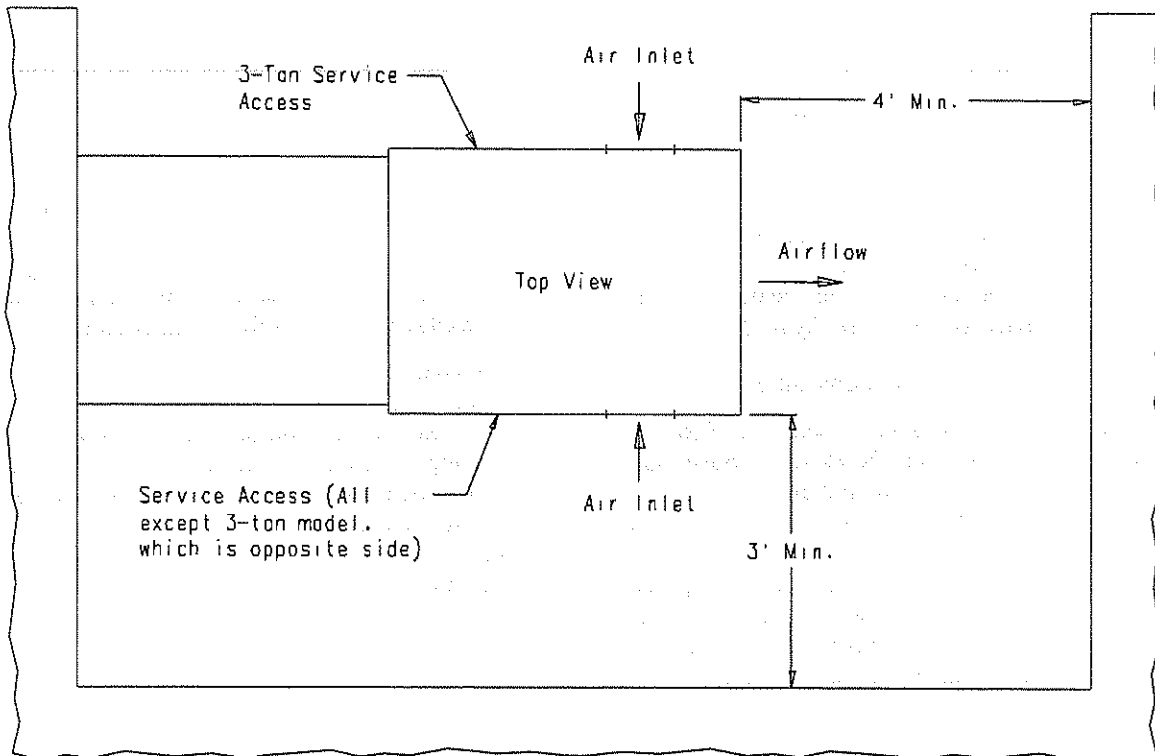

MIS-1185

FIGURE 5
ROOF TOP APPLICATION
(MAY ALSO BE REQUIRED FOR GROUND LEVEL INSTALLATIONS.)

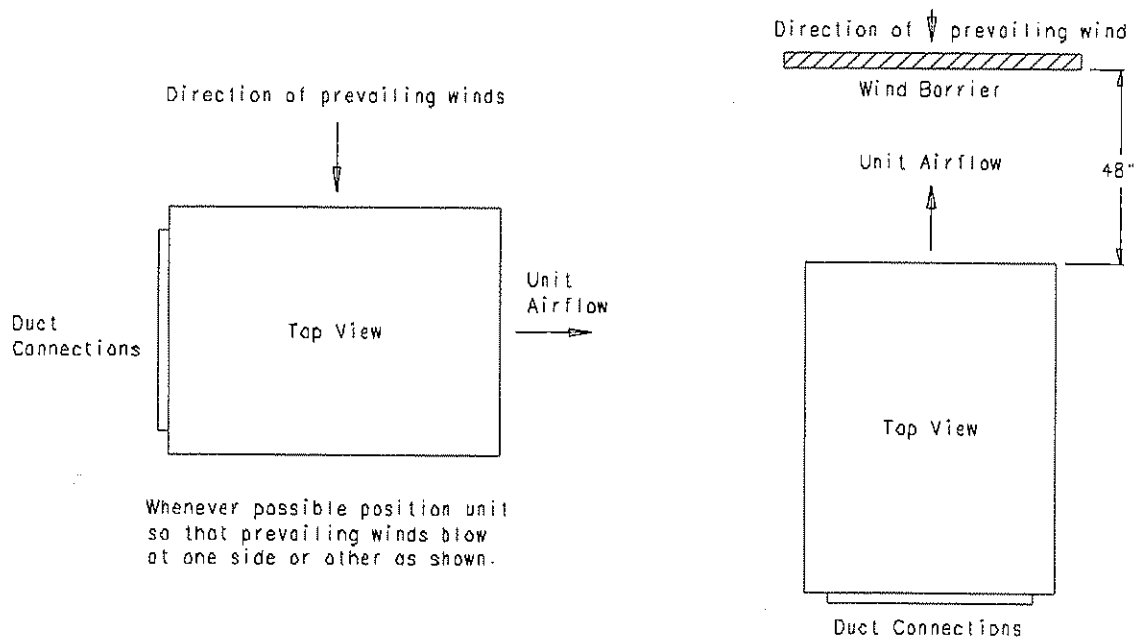

Whenever possible position unit so that prevailing winds blow at one side or other as shown.

If outdoor coil must face prevailing wind, construct a wind barrier to secure proper defrost.

MIS-1176

FIGURE 6
SLAB MOUNTING AT GROUND LEVEL
(ABOVE 32° F OUTSIDE TEMPERATURE)

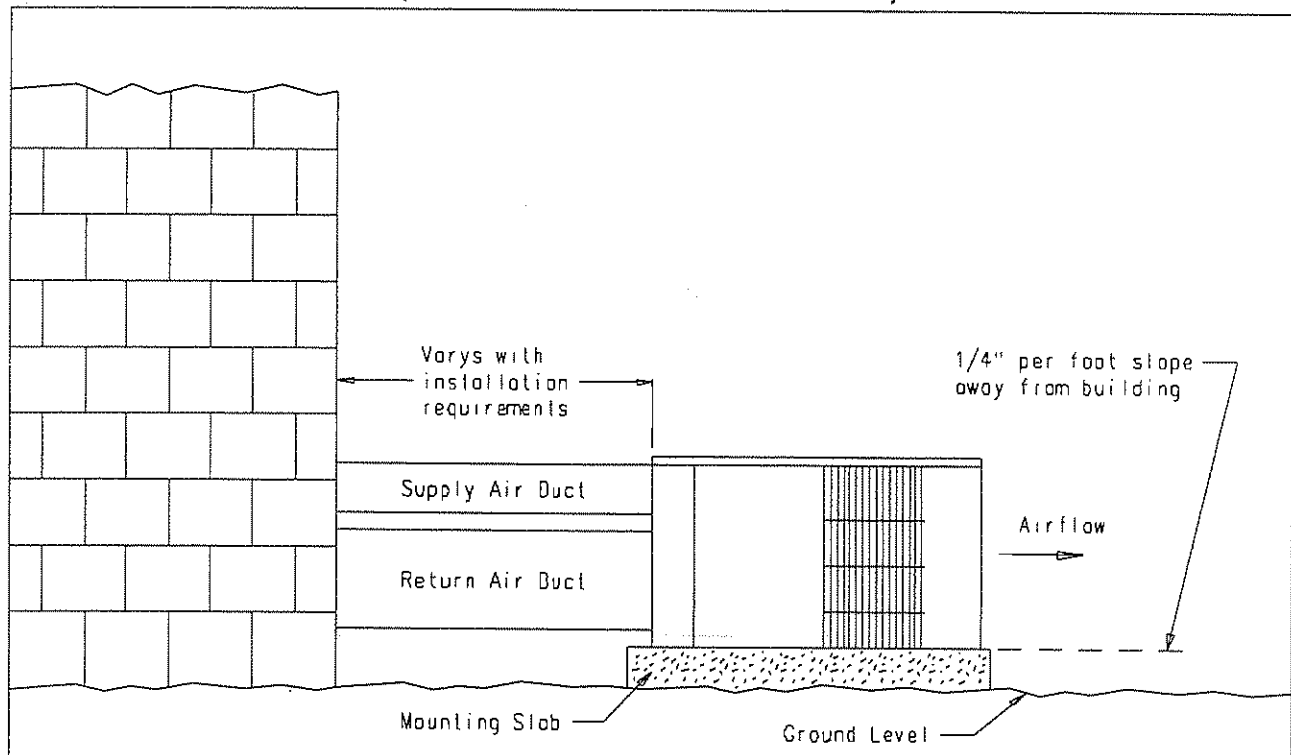

MIS-1184

3. **SLAB MOUNTED AT GROUND LEVEL** – This type installation is ideal for homes with a slab floor construction where a roof mounted unit is not desired. The supply and return duct work can be run through a furred closet space.
4. **THROUGH THE WALL** – This type installation requires a suitable framework to be fabricated capable of withstanding the unit weight. Normally the unit will be insulated so as to minimize supply and return duct work.
5. **OTHER INSTALLATIONS** – Many other installations are possible with the packaged air conditioner. No matter what the installation, always consider the following facts:
 - A. Insure that the discharge air is not obstructed in any way so as to cause operation difficulties.
 - B. The indoor coil drain pan is equipped with a coupling that must be piped through a condensate drain trap to a suitable drain.
 - C. Always mount the unit in such a position that it may be easily reached for servicing and maintenance.
 - D. Insure that the unit is clear so that proper air flow over the outdoor coil will be maintained.

If this unit is operated in cooling below a 65° outdoor ambient temperature, the installation of low ambient controls (CMA-6) to unit is required.

CONDENSATE DRAIN TRAP

It is very important to provide a trap in the condensate drain line to allow a positive liquid seal in the line and assure correct drainage from the coil condensate pan.

Install condensate drain trap shown in Figure 7. Use drain connection size or larger. Do not operate unit without trap. Unit must be level or slightly inclined

toward drain. With a trap installed on a unit located in an unconditioned area, water in the trap may freeze. It is recommended that the trap material be of a type that will allow for expansion of water when it freezes.

AIR FILTERS

Air filters for the return air side of the system are not provided as part of these models, and must be field supplied and installed as part of the final installation.

Prior thought should be given to return air location and placement of the air filter(s). The air filter(s) must be of adequate size and readily accessible to the operator of the equipment. Filters must be adequate in size and properly maintained for proper operation. If this is not done, excessive energy use, poor performance, and multiple service problems will result. *It is impossible to oversize air filters.* Generous sizing will result in cleaner air and coils as well as lower operating costs and extend the time between required changes. Table 5 shows minimum filter areas and recommended filter sizes. Actual filter sizes can vary with the installation due to single or multiple returns utilizing a filter/grille arrangement or being placed immediately ahead of the indoor coil face in the return air duct.

TABLE 5

Model	Minimum Filter Areas	Recommended Size
P1242A1	608 square inches	(2) 16 x 20 x 1
P1248A1	(4.62 square feet)	

NOTE: If roof hood accessory is to be used, information on air filters may be found under that heading in this manual. Air filters are supplied as part of that package.

FIGURE 7
CONDENSATE DRAIN TRAP

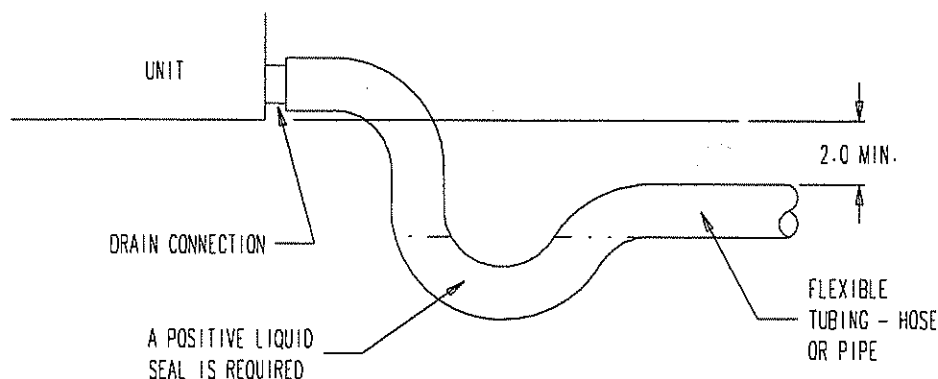

WIRING – MAIN POWER

Refer to the unit rating plate for wire sizing information and maximum fuse size. Each outdoor unit is marked with a “Minimum Circuit Ampacity”. This means that the field wiring used must be sized to carry that amount of current. If field installed heaters are added to the basic unit, a second separate power supply circuit will be required. The heater rating plate located adjacent to the basic unit rating plate will show the appropriate circuit ampacity fuse size, etc. (Also see “Electrical Data” on pages 2 and 3.) *All models are suitable for connection with copper wire only.* These instructions *must* be adhered to. Refer to the National Electrical Code for complete current carrying capacity data on the various insulation grades of wiring material.

The electrical specifications on page 2 and 3 lists fuse and wire sizes (75°F copper) for all models including the most commonly used heater sizes.

The unit rating plate lists a “Maximum Time Delay Fuse” or “HACR” type circuit breaker that is to be used with the equipment. The correct size must be used for proper circuit protection and also to assure that there will be no nuisance tripping due to the momentary high starting current of the compressor.

WIRING – 24V LOW VOLTAGE CONTROL CIRCUIT

Five (5) wires should be run from thermostat subbase to the 24V terminal board in the unit. A five conductor, 18 gauge copper, color-coded thermostat cable is recommended. The connection points are shown in Figure 8.

**TABLE 6
THERMOSTAT WIRE SIZE**

Transformer VA	FLA	Wire Gauge	Maximum Distance in Feet
55	2.3	20	45
		18	60
		16	100
		14	160
		12	250

TRANSFORMER TAPS

230/208V, 1 phase and 3 phase equipment employ dual primary voltage transformers. All equipment leaves the factory wired on 240V tap. For 208V operation, reconnect from 240V to 208V tap. The acceptable operating voltage range for the 240 and 208V taps are:

TAP	RANGE
240	253 – 216
208	220 – 187

NOTE: The voltage should be measured at the field power connection point in the unit and while the unit is operating at full load (maximum amperage operating condition).

THERMOSTATS

See specific wiring information for the different models, heater KWs, and voltages on pages 13 and 14.

**TABLE 7
WALL THERMOSTAT AND SUBBASE COMBINATIONS**

Thermostat	Subbase	Predominate Features
8403-002 T87F3111	8404-003 Q539A1220	1 stage heat, 1 stage cool, Mercury System: Heat-off-cool Fan: on-auto
8403-041 T8034C1499	—	1 stage heat, 1 stage cool, Mercury System: Heat-off-cool Fan: on-auto
8403-049 1F93-380	—	2 stage heat, 2 stage cool Electronic Programmable
8403-043 CM200	—	1 stage heat, 1 stage cool, Mercury System: Heat-off-cool Fan: on-auto Snap Action
8403-048 T8400C1313	—	1 stage heat, 1 stage cool, Mercury System: Heat-off-cool Fan: on-auto Electronic Non-Programmable
8403-019 T874C1760	8404-012 Q674A1001	2 stage heat, 1 stage cool, Mercury System: heat-auto-cool Fan: on-auto

IMPORTANT NOTE: *Only the thermostat and subbase combinations as shown above will work with this equipment. The thermostat and subbase MUST be matched, and correct operation can be assured only by proper selection and application of these parts.*

FIGURE 8
LOW VOLTAGE WIRING

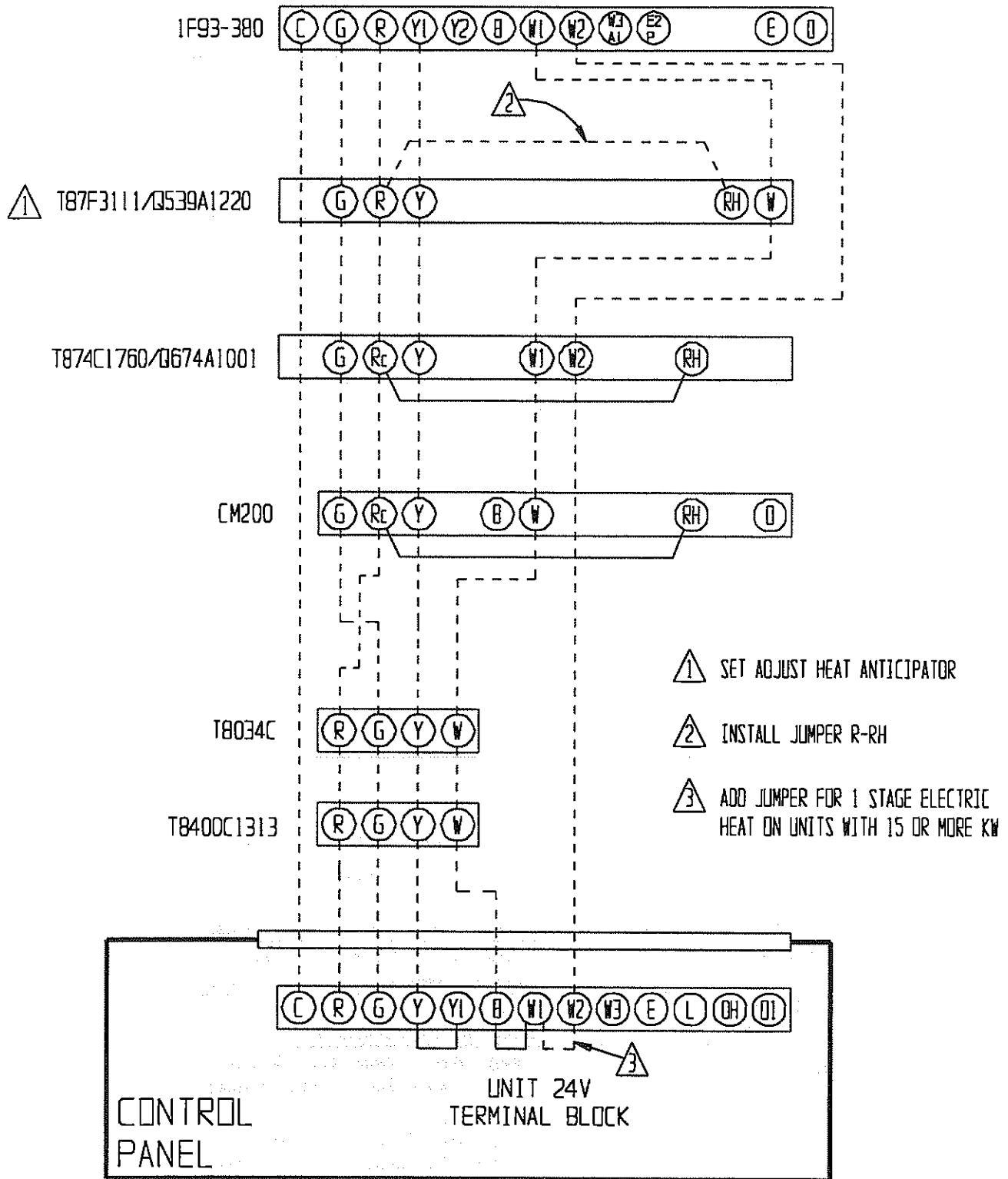

MIS-1180

START UP AND OPERATION

THREE PHASE SCROLL COMPRESSOR START UP INFORMATION

Scroll compressors, like several other types of compressors, will only compress in one rotational direction. Direction of rotation is not an issue with single phase compressors since they will always start and run in the proper direction.

However, three phase compressors will rotate in either direction depending upon phasing of the power. Since there is a 50-50 chance of connecting power in such a way as to cause rotation in the reverse direction, verification of proper rotation must be made.

Verification of proper rotation direction is made by observing that suction pressure drops and discharge pressure rises when the compressor is energized. Reverse rotation also results in an elevated sound level over that with correct rotation, as well as, substantially reduced current draw compared to tabulated values.

Verification of proper rotation must be made at the time the equipment is put into service. If improper rotation is corrected at this time there will be no negative impact on the durability of the compressor. However, reverse operation for over one hour may have a negative impact on the bearing due to oil pump out.

NOTE: If compressor is allowed to run in reverse rotation for several minutes the compressor's internal protector will trip.

All three phase ZR*3 compressors are wired identically internally. As a result, once the correct phasing is determined for a specific system or installation, connecting properly phased power leads to the same Fusite terminals should maintain proper rotation direction.

The direction of rotation of the motor may be changed by reversing any two line connections to the unit.

SEQUENCE OF OPERATION

COOLING – Circuit R-Y makes at thermostat pulling in compressor contactor starting the compressor and outdoor motor. The G (indoor motor) circuit is automatically completed on any call for cooling operation, or can be energized by manual fan switch on subbase for constant air circulation.

HEATING – A circuit R-W1 is completed on each heating cycle energizing electric heat if so equipped.

START UP NOTES

For improved start up performance, wash the indoor coil with dishwasher detergent.

INDOOR BLOWER MOTOR

These models feature a variable speed (ECM) motor providing high efficiency, low sound levels and soft start capabilities. The motor is self adjusting to provide the proper air flow rate at duct static pressures up to 0.50" WC without user adjustment or wiring changes.

On command from the wall thermostat the motor will start slowly and ramp up to full speed over a period of 10- 15 seconds.

When the thermostat is satisfied the blower will operate for approximately 1 minute, and then slow down and stop.

COMPRESSOR CONTROL MODULE

The compressor control is an anti-short cycle/lockout timer with high and low pressure switch monitoring and alarm output.

ADJUSTABLE DELAY-ON-MAKE AND BREAK TIMER

On a call for compressor operation the *delay-on-make* period begins which will be 10% of the *delay-on-break* setting. When the delay-on-make is complete and the high pressure switch (and low pressure switch if employed) is closed, the compressor contactor is energized. Upon shutdown the delay-on-break timer starts and prevents restart until the delay-on-break and delay-on-make periods have expired.

HIGH PRESSURE SWITCH AND LOCKOUT SEQUENCE (Standard Feature)

If the high pressure switch opens, the compressor contactor will de-energize immediately. The lockout timer will go into a *soft lockout* and stay in soft lockout until the high pressure switch closes **and** the delay-on-make time has expired. If the high pressure switch opens again in this same operating cycle the unit will go into *manual lockout* condition and the alarm circuit will energize. Recycling the wall thermostat resets the manual lockout.

LOW PRESSURE SWITCH, BYPASS, AND LOCKOUT SEQUENCE

NOTE: The low pressure switch is an optional control and the bypass and lockout sequence are part of the standard compressor control module.

If the low pressure switch opens for more than 120 seconds, the compressor contactor will de-energize and go into a soft lockout. Regardless the state of the low pressure switch, the contactor will reenergize after the delay-on-make time delay has expired. If the low pressure switch remains open or opens again for longer than 120 seconds the unit will go into manual lockout condition and the alarm circuit will energize. Recycling the wall thermostat resets the manual lockout.

ALARM OUTPUT

Alarm terminal is output connection for applications where alarm signal is desired. This terminal is powered whenever compressor is locked out due to HPC or LPC sequences as described.

NOTE: Both high and low pressure switch controls are inherently automatic reset devices. The high pressure switch and low pressure switch cut out and cut in settings are fixed by specific air conditioner or heat pump unit model. The lockout features, both soft and manual, are a function of the Compressor Control Module.

ADJUSTMENTS

ADJUSTABLE DELAY-ON-MAKE AND DELAY-ON-BREAK TIMER

The potentiometer is used to select Delay-on-Break time from 30 seconds to 5 minutes. Delay-on-Make (DOM) timing on power-up and after power interruptions is equal to 2 minutes plus 10% of Delay-on-Break (DOB) setting:

0.5 minute (30 seconds)	DOB = 123 second	DOM
1.0 minute (60 seconds)	DOB = 126 second	DOM
2.0 minute (120 seconds)	DOB = 132 second	DOM
3.0 minute (160 seconds)	DOB = 138 second	DOM
4.0 minute (240 seconds)	DOB = 144 second	DOM
5.0 minute (300 seconds)	DOB = 150 second	DOM

SERVICE AND TROUBLESHOOTING

SERVICE HINTS

1. Caution homeowner to maintain clean air filters at all times. Also, not to needlessly close off supply and return air registers. This reduces air flow through the system which shortens equipment service life as well as increasing operating costs.
2. Check all power fuses or circuit breakers to be sure that they are the correct rating.
3. Periodic cleaning of the outdoor coil to permit full and unrestricted airflow circulation is essential.

PRESSURE SERVICE PORTS

High and low pressure service ports are installed on all units so that the system operating pressures can be observed. Pressure tables can be found in Table 10 in this manual covering all models on cooling cycle. It is imperative to match the correct pressure table to the unit by model number.

REFRIGERANT CHARGE

The correct system R-22 charge is shown on the unit rating plate. Optimum unit performance will occur with a refrigerant charge resulting in a suction line temperature (6" from compressor) as shown in Table 8.

TABLE 8

Model	Rated Airflow	95 Degree F OD Temperature	82 Degree F OD Temperature
P1242A1	1400	57 - 59	58 - 60
P1248A1	1550	55 - 57	59 - 61

The above suction line temperatures are based upon 80°F dry bulb/67°F wet bulb (50% RH) temperature and rated airflow across the evaporator during cooling cycle.

FAN BLADE SETTINGS

Shown in Figure 9 are the correct fan blade setting dimensions for proper air delivery across the outdoor coil.

Any service work requiring removal or adjustment in the fan and/or motor area will require that the dimensions below be checked and blade adjusted in or out on the motor shaft accordingly.

FIGURE 9
FAN BLADE SETTING DIMENSIONS

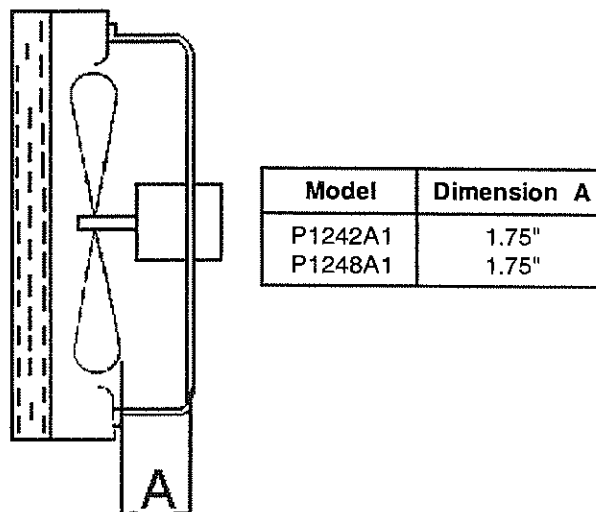

SUCTION AND DISCHARGE TUBE BRAZING

Compliant Scroll compressors have copper plated steel suction and discharge tubes. These tubes are far more rugged and less prone to leaks than copper tubes used on other compressors. Due to different thermal properties of steel and copper, brazing procedures may have to be changed from those commonly used.

- To disconnect: heat joint Areas 2 and 3 slowly and uniformly until braze material softens and the tube can be pulled out of suction fitting. (See Figure 10.)
- To connect:
 - Recommended brazing materials: silfos with minimum 5% silver or silver braze material with flux.
 - Reinsert tube into fitting.
 - Heat tube uniformly in Area 1 moving slowly to Area 2. When joint reaches brazing temperature, apply brazing material. (See Figure 10.)
 - Heat joint uniformly around the circumference to flow braze material completely around the joint.
 - Slowly move torch into Area 3 to draw braze material into joint. (See Figure 10.)
 - *Do not* overheat joint.

**FIGURE 10
BRAZING DIAGRAM**

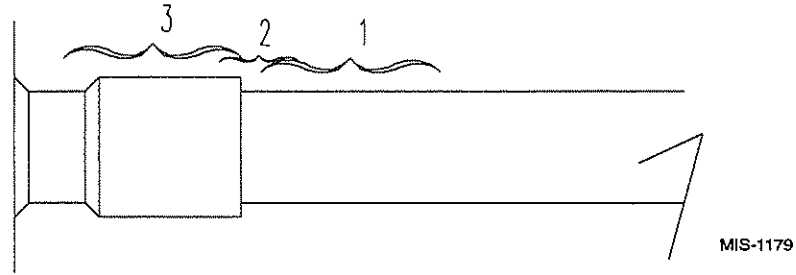
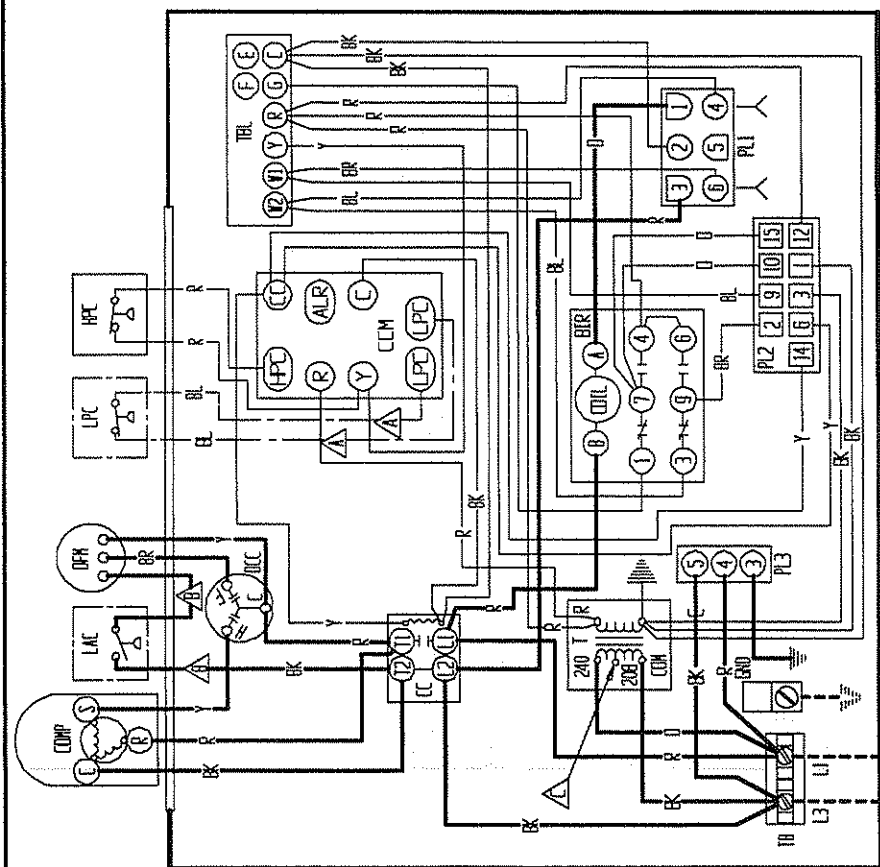
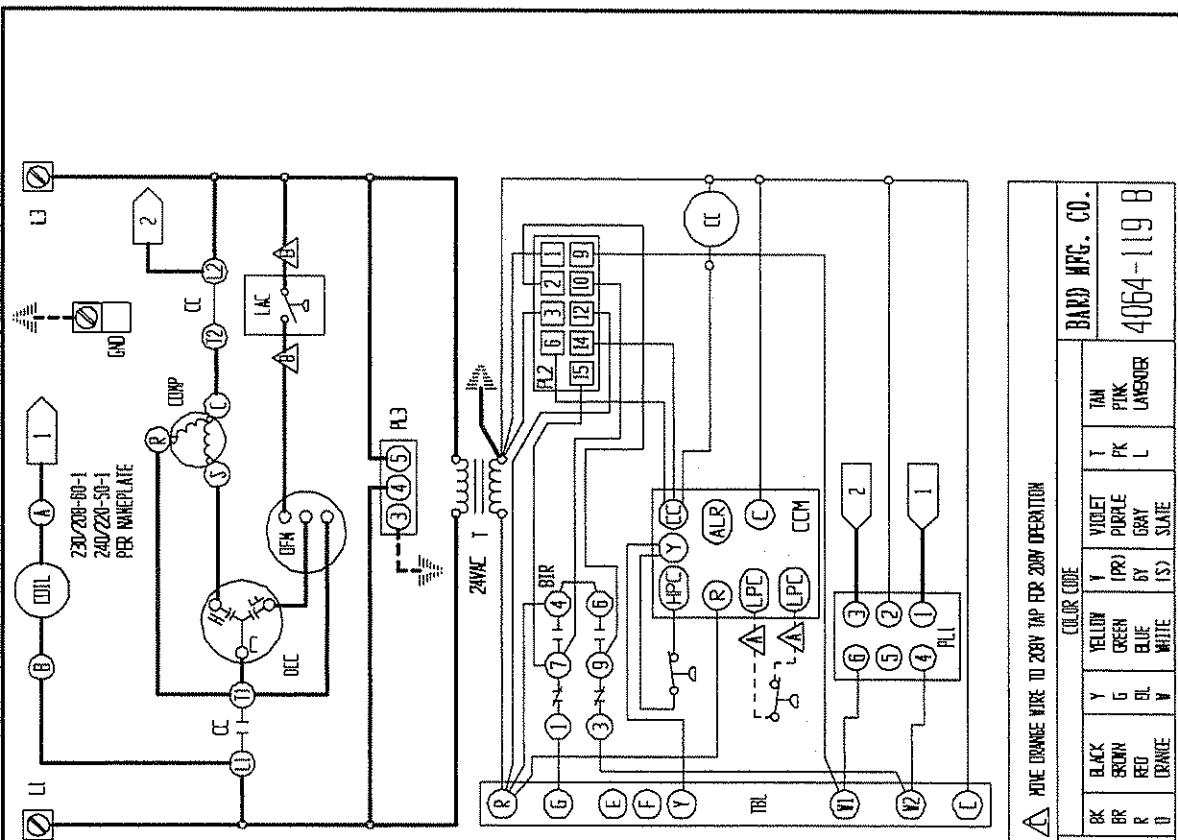

**TABLE 9
PRESSURE TABLE**

COOLING

Air Temperature Entering Outdoor Coil Degrees

Model	Return Air Temperature	Pressure	75	80	85	90	95	100	105	110	115
PH1242	75 deg. DB	Low Side	70	72	74	76	78	79	80	81	82
	62 deg. WB	High Side	192	206	220	236	252	268	286	304	323
	80 deg. DB	Low Side	75	77	79	81	83	85	86	87	88
PH1248	67 deg. WB	High Side	197	211	226	242	258	275	293	312	331
	85 deg. DB	Low Side	78	80	82	84	86	88	89	90	91
	72 deg. WB	High Side	204	218	234	250	267	285	303	323	343
PH1248	75 deg. DB	Low Side	70	72	73	75	77	79	79	81	83
	62 deg. WB	High Side	200	215	230	247	263	281	298	317	336
	80 deg. DB	Low Side	75	77	78	80	82	84	85	87	89
PH1248	67 deg. WB	High Side	205	220	236	253	270	288	306	325	345
	85 deg. DB	Low Side	78	80	81	83	85	87	88	90	92
	72 deg. WB	High Side	212	228	244	262	279	298	317	336	357



230/208-60-1
240/220-50-1
PER NAMEPLATE

USE COPPER CONDUCTORS ONLY
SUITABLE FOR AT LEAST 75° C

COMPONENT CODE	
BIR	BLOWER INTERLOCK RELAY
CC	COMPRESSOR CONTACTOR
CCM	COMPRESSOR CONTROL MODULE
COMP	COMPRESSOR
DFA	DUAL CAN CAPACITOR
GND	EQUIPMENT GROUND
HPC	HIGH PRESSURE CONTROL
LAC	LOW AMBIENT CONTROL
LPR	LOW PRESSURE BYPASS
LPC	LOW PRESSURE CONTROL
OFM	OUTDOOR FAN MOTOR
PL1	PLUG #1
PL2	PLUG #2
PL3	PLUG #3
T	TRANSFORMER
TB	TERMINAL BLOCK
TRL	LOW VOLTAGE TERMINAL BLOCK

FACTORY STD.		FIELD		OPTIONAL	
HIGH VOLTAGE	---	---	---	---	---
LOW VOLTAGE	---	---	---	---	---
ACCESSORY	---	---	---	---	---

▲ WIRE ORANGE WIRE TO 208V TAP FOR 208V OPERATION

COLOR CODE	
BK	BLACK
BR	BROWN
R	RED
D	DRANCE
Y	YELLOW
G	GREEN
BL	BLUE
W	WHITE
PR	PURPLE
BY	GRAY
IS	STATE
PK	PINK
L	LANGUER
TAN	TAN

▲ LAMELED WIRES CONNECT IF NO OPTIONS USED.

BARID MFG. CO.
4064-119 B

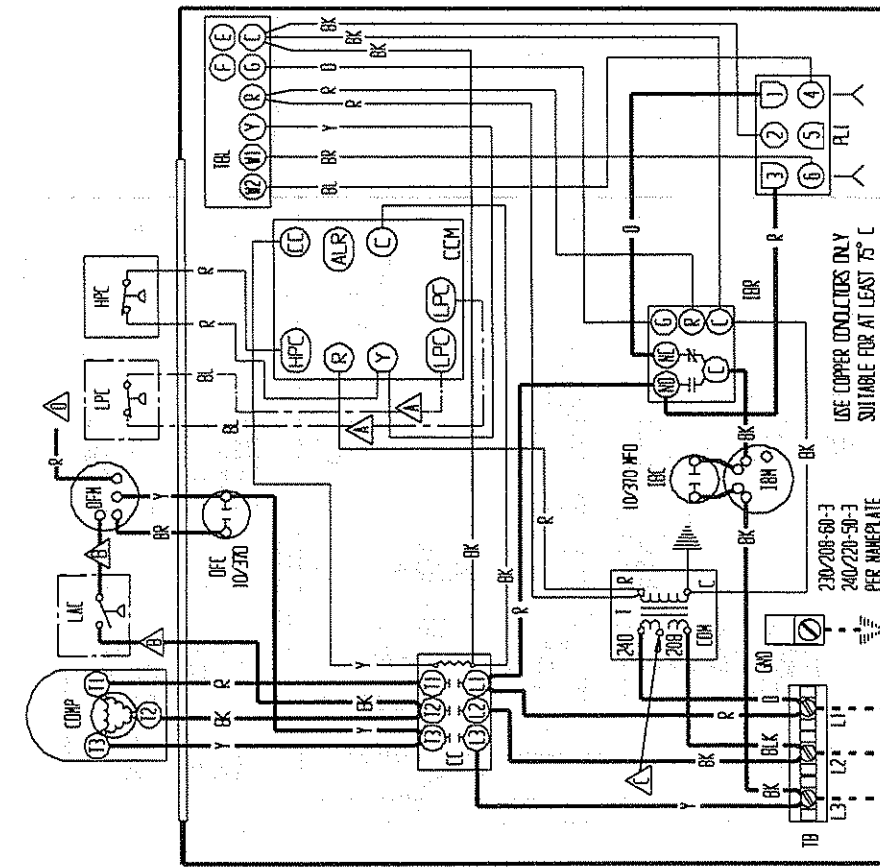
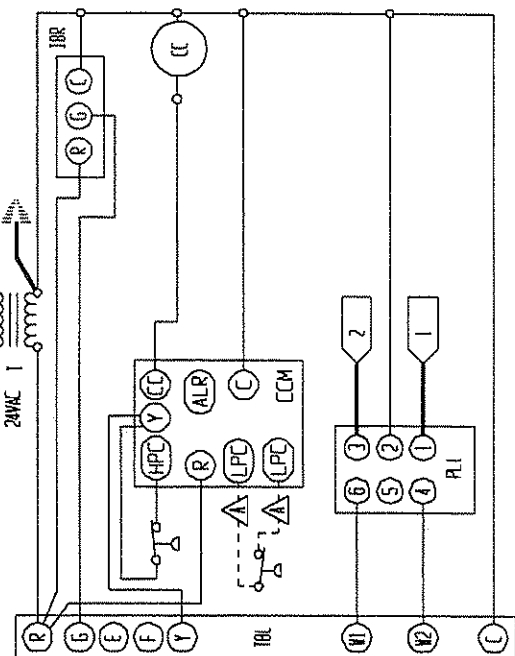
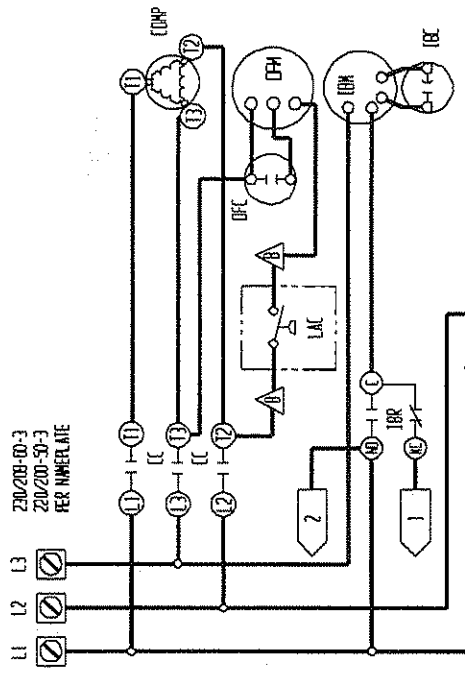

COMPONENT CODE		COLOR CODE		WIRE COLOR		
CC	COMPRESSOR CONTACTOR	Y	YELLOW	Y	PK	I
CH	COMPRESSOR CONTROL MODULE	G	GREEN	PK	PK	L
COMP	COMPRESSOR	BL	BLUE	BL	L	L
OC	OVERCURRENT PROTECTIVE DEVICE	BR	BROWN	BR	BR	BR
GND	EQUIPMENT GROUND	R	RED	R	R	R
HPC	HIGH PRESSURE CONTROL	Y	YELLOW	Y	PK	I
IBC	INDOOR BLOWER MOTOR	BL	BLUE	BL	L	L
IBM	INDOOR BLOWER MOTOR RELAY	BR	BROWN	BR	BR	BR
IBR	INDOOR BLOWER RELAY	R	RED	R	R	R
LAC	LOW AMBIENT CONTROL	Y	YELLOW	Y	PK	I
LPC	LOW PRESSURE CONTROL	BL	BLUE	BL	L	L
LFC	LOW FREQUENCY CAPACITOR	Y	YELLOW	Y	PK	I
PLI	PLUG IN	BL	BLUE	BL	L	L
T	TRANSFORMER	Y	YELLOW	Y	PK	I
TBL	TERMINAL BLOCK	Y	YELLOW	Y	PK	I
IBR	INDOOR BLOWER RELAY	R	RED	R	R	R
IBM	INDOOR BLOWER MOTOR	BR	BROWN	BR	BR	BR
IBL	INDOOR BLOWER LINE	Y	YELLOW	Y	PK	I

FACTORY STD.	FIELD	OPTIONAL
---	---	---
---	---	---
---	---	---
---	---	---
---	---	---
---	---	---
---	---	---
---	---	---

NOTE: RED WIRE TO 208V TAP FOR 208V OPERATION. RED WIRE FOR 50 HZ. OPERATION ONLY.

WIRE COLOR: BK (BLACK), BR (BROWN), R (RED), Y (YELLOW), G (GREEN), BL (BLUE), PK (PURPLE), V (VIOLET), I (INDIAN PINK), L (LAVENDER).

WIRE NUMBERING: 1, 2, 3, 4, 5, 6, 7, 8, 9, 10, 11, 12.

COMPONENTS: COMP, LAC, DFC, HPC, ALR, C, LFC, CCM, IBR, IBM, TBL, PLI.

WIRING: L1, L2, L3, GND, 240VAC 1, 10/370 MFD, 200, 240, 208.

WIRING TABLE: 1 (Y), 2 (G), 3 (BL), 4 (R), 5 (Y), 6 (BL), 7 (R), 8 (Y), 9 (BL), 10 (R), 11 (Y), 12 (BL).