INSTALLATION INSTRUCTIONS

SINGLE PACKAGE HEAT PUMPS

Models:

PH11242	PH12241
PH11301	PH1230
PH11361	PH1236
PH11422	PH1242
PH10481	PH11481
PH1060	



CLIMATE CONTROL SOLUTIONS

Bard Manufacturing Company
Bryan, Ohio 43506

*Since 1914 . . . Moving ahead, just as
planned.*

Manual : 2100-354B
Supersedes: 2100-354A
File: Volume II Tab 11
Date: 03-19-03

CONTENTS

Getting Other Informations and Publications

General Instructions

Important	2
Shipping Damage	2
General	2
Field-Installed Heater Packages (Optional)	2

Installation

Location	9
Typical Installations	9
Condensate Drain Trap	14
Air Filters	14
Wiring – Main Power	15
Wiring – 24V Low Voltage Control Circuit	15
Thermostats	16
Thermostat Indicator Lamps	17
Emergency Heat Position	17
Transformer Taps	17
Compressor Cutoff Thermostat and Outdoor Thermostat Wiring	17

Figures

Figure 1 Unit Dimensional Drawing	8
Figure 2 Slab Mounting at Ground Level	10
Figure 3 Airflow and Service Access Clearances	10
Figure 4 Roof Top Application	11
Figure 5 Elevated Mounting Platforms	11
Figure 6 Prefabricated Rood Curb Specifications	12
Figure 7 Field Fabricated Curbing	13
Figure 8 Condensate Drain Trap	14
Figure 9 Low Voltage Wiring	15
Figure 10 Unit 24V Terminal Board (5–10 KW)	17
Figure 11 Unit 24V Terminal Board (15–20 KW) ...	18
Figure 12 Heat Pump Control Board	20
Figure 13 Fan Blade Setting	23
Figure 14 Brazing Diagram	24

Start Up and Operation

Three Phase Scroll Compressor Start Up Information	19
Sequence of Operation	19
Defrost Cycle	20

Troubleshooting

Solid State Heat Pump Control Troubleshooting Procedure	21
Troubleshooting Guide	21
Checking Temperature Sensor Check Out	22
Temperature vs. Resistance of Temperature Sensor Chart	22

Service

Service Hints	23
Pressure Service Ports	23
Refrigerant Charge	23
Fan Blade Settings	23
Suction and Discharge Tube Brazing	24
Troubleshooting ECM Blower Motors	25 & 26
Pressure Tables	27-30

Tables

Table 1 Rated CFM and ESP	2
Table 2 Electrical Data	3
Table 2A Electrical Data	4
Table 2B Electrical Data	5
Table 3 Optional Field Installed Heater Packages	6
Table 4 Electric Heater Table	7
Table 5 Dimensions of Unit	8
Table 6 Roof Curb Dimensions	12
Table 7 Thermostat Wire Size	13
Table 8 Wall Thermostat and Subbase Combinations	9
Table 9 Required Filters	14
Table 10 Thermostat Wire Size	16
Table 11 Compressor Cutoff Thermostat Wiring (5 - 10 KW)	18
Table 12 Compressor Cutoff Thermostat Wiring (15 - 20 KW)	18
Table 13 Refrigerant Charge	23
Table 14 Fan Blade Setting Dimensions	23
Table 15 Indoor Blower Performance	24
Table 16 Pressure Table - Cooling	27
Table 17 Pressure Table - Heating	27
Table 18 Pressure Table - Cooling	28
Table 19 Pressure Table - Heating	28
Table 20 Pressure Table - Cooling	29
Table 21 Pressure Table - Heating	29
Table 22 Pressure Table - Cooling	30
Table 23 Pressure Table - Heating	30

Getting Other Information and Publications

These publications can help you install the air conditioner or heat pump. You can usually find these at your local library or purchase them directly from the publisher. Be sure to consult current edition of each standard.

National Electrical Code ANSI/NFPA 70

Standard for the Installation ANSI/NFPA 90A
of Air Conditioning and
Ventilating Systems

Standard for Warm Air ANSI/NFPA 90B
Heating and Air
Conditioning Systems

Load Calculation for ACCA Manual J
Residential Winter and
Summer Air Conditioning

Duct Design for Residential ACCA Manual D
Winter and Summer Air Conditioning
and Equipment Selection

FOR MORE INFORMATION, CONTACT THESE PUBLISHERS:

ACCA **Air Conditioning Contractors of America**
1712 New Hampshire Ave. N.W.
Washington, DC 20009
Telephone: (202) 483-9370
Fax: (202) 234-4721

ANSI **American National Standards Institute**
11 West Street, 13th Floor
New York, NY 10036
Telephone: (212) 642-4900
Fax: (212) 302-1286

ASHRAE **American Society of Heating Refrigerating,
and Air Conditioning Engineers, Inc.**
1791 Tullie Circle, N.E.
Atlanta, GA 30329-2305
Telephone: (404) 636-8400
Fax: (404) 321-5478

NFPA **National Fire Protection Association**
Batterymarch Park
P.O. Box 9101
Quincy, MA 02269-9901
Telephone: (800) 344-3555
Fax: (617) 984-7057

GENERAL INSTRUCTIONS

IMPORTANT

The equipment covered in this manual is to be installed by trained, experienced service and installation technicians. Any heat pump is more critical of proper operating charge and an adequate duct system than a straight air conditioning unit. All duct work, supply and return ducts, must be properly sized for the design air flow requirement of the equipment. ACCA is an excellent guide to proper sizing. All duct work or portions thereof not in the conditioned space should be properly insulated in order to both conserve energy and prevent condensation or moisture damage.

SHIPPING DAMAGE

Upon receipt of equipment, the carton should be checked for external signs of shipping damage. If damage is found, the receiving party must contact the last carrier immediately, preferably in writing, requesting inspection by the carrier's agent.

GENERAL

The refrigerant system is completely assembled and charged. All internal wiring is complete.

The unit is designed for use with or without duct work. Flanges are provided for attaching the supply and return ducts.

These instructions explain the recommended method to install the air cooled self-contained unit and the electrical wiring connections to the unit.

These instructions and any instructions packaged with any separate equipment required to make up the entire heat pump system should be carefully read before beginning the installation. Note particularly "Starting Procedure" and any tags and/or labels attached to the equipment.

While these instructions are intended as a general recommended guide, they do not supersede any national and/or local codes in any way. Authorities having jurisdiction should be consulted before the installation is made.

FIELD INSTALLED HEATER PACKAGES (OPTIONAL)

These packaged heat pumps are manufactured without supplementary electric heaters. Supplementary heaters are available for simple, fast field installation.

A separate power circuit is required for the supplementary heaters.

IMPORTANT: Refer to Table 1 when designing duct work for maximum available static pressure with heater installed.

Refer to electrical data shown in Tables 3 and 4 for proper application information on all available heater combinations and what units they can be used with. It also shows the applicable circuit ampacities, fuse size, and wire size for each heater combination.

**TABLE 1
RATED CFM AND EXTERNAL STATIC PRESSURE (ESP)**

Model	Rated CFM	Recommended Airflow Range	Rated ESP	Maximum ESP
PH11242	800	680-880	0.20	0.50
PH12241	800	<i>Note 1</i>	0.10	0.50
PH11301	1000	775-1100	0.30	0.40
PH1230	1000	<i>Note 1</i>	0.15	0.50
PH11361	1000	775-1210	0.20	0.40
PH1236	1000	<i>Note 1</i>	0.15	0.50
PH11422	1400	1260-1540	0.20	0.35
PH1242	1400	<i>Note 1</i>	0.15	0.50
PH10481	1550	1400-1700	0.40	0.50
PH12481	1550	<i>Note 1</i>	0.20	0.50
PH1060	1700	1530-1870	0.20	0.50

NOTE: Motor will adjust to deliver rated airflow.

**TABLE 2
ELECTRICAL DATA**

Model	PH11242	PH11301	PH11361	PH11361-B	PH11361-C	PH11422
Electric Rating 60 Hz - Ckt A	230/208-60-1	230/208-60-1	230/208-60-1	230/208-60-3	460-60-3	230/208-60-1
Operating Voltage Range	197-253	197-253	197-253	187-253	414-506	197-253
Minimum Circuit Ampacity	17	21	25	18	12	29
BCSC	11	13.5	18	11	6	18.5
Field Wire Size *	10	10	8	10	14	8
Ground Wire Size	10	10	10	10	14	10
Delay Fuse - Max. **	25	30	40	25	15	50
Total Unit Amps - 203-208	13.9/14.9	15.7/17.2	18.9/20.7	13.2/13.8	6.9	22.8/24.2
Compressor - Circuit A						
Compressor Type	Scroll	Scroll	Scroll	Scroll	Scroll	Scroll
Volts	230/208	230/208	230/208	230/208	460	230/208
Rated Load Amps	10/11	11.5/13	14.7/16.5	9.0/9.6	4.7	17.1/18.5
Lock Roter Amps	54/54	72.5/72.5	88/88	77/77	39	104/104
Fan Motor and Condenser						
Fan Motor - HP/RPM	1/5 - 1090	1/5 - 1075	1/5 - 1075	1/5 - 1075	1/5 - 1075	1/3 - 825
Fan Motor Amps	1.8	1.6	1.6	1.6	0.8	2.5
Fan Dia/CFM	20"/1650	20"/2000	20"/2000	20"/2000	20"/2000	24"/2950
Motor and Evaporator						
Blower Motor - HP/RPM	1/3 - 1075	1/3 - 1075	1/3 - 1075	1/3 - 1075	1/3 - 1075	1/2 - 1075
Blower Motor - Amps	2.1	2.6	2.6	2.6	1.4	3.2
CFM Cooling & ESP	800 @ 0.20	1100 @ 0.30	1100 @ 0.20	1100 @ 0.20	1100 @ 0.20	1400 @ 0.20
Charge (R22 oz.)	88	93	86	86	86	121
Shipping Weight (pounds)	365	365	365	365	365	435

* 75 degree C copper wire

** Maximum time delay fuse of HACR type circuit breaker

**TABLE 2A
ELECTRICAL DATA**

Model	PH10481	PH10481-B	PH10481-C	PH1060	PH1060-B	PH1060-C
Electric Rating 60 Hz - Ckt A	230/208-60-1	230/208-60-3	460-60-3	230/208-60-1	230/208-60-3	460-60-3
Operating Voltage Range	197-253	187-253	414-506	197-253	187-253	414-506
Minimum Circuit Ampacity	33	24	12	42	28	14
BCSC	21.5	14.7	7.1	29	18	9
Field Wire Size *	8	8	12	8	8	12
Ground Wire Size	10	10	10	10	10	12
Delay Fuse - Max. **	50	35	15	60	45	20
Total Unit Amps - 203-208	25.2/21.2	18.3/19.7	9	30.3/32.5	21.3/22.8	11
Compressor - Circuit A						
Compressor Type	Scroll	Scroll	Scroll	Scroll	Scroll	Scroll
Volts	230/208	230/208	460	230/208	230/208	460
Rated Load Amps	19.5/21.5	12.6/14.0	6.2	24.6/26.8	15.6/17.1	8.2
Lock Roter Amps	137/137	91/91	50	148/148	137/137	62
Fan Motor and Condenser						
Fan Motor - HP/RPM	1/3 - 850	1/3 - 850	1/3 - 850	1/3 - 850	1/3 - 850	1/3 - 850
Fan Motor Amps	2.5	2.5	1.2	2.5	2.5	1.2
Fan Dia/CFM	24"/3000	24"/3000	24"/3000	24"/3000	24"/3000	24"/3000
Motor and Evaporator						
Blower Motor - HP/RPM	1/2 - 1075	1/2 - 1075	1/2 - 1075	1/2 - 1075	1/2 - 1075	1/2 - 1075
Blower Motor - Amps	3.2	3.2	1.6	3.2	3.2	1.6
CFM Cooling & ESP	1550 @ 0.40	1550 @ 0.40	1550 @ 0.40	1700 @ 0.20	1700 @ 0.20	1700 @ 0.20
Charge (R22 oz.)	125	125	125	157	157	157
Shipping Weight (pounds)	450	450	450	450	450	450

* 75 degree C copper wire

** Maximum time delay fuse of HACR type circuit breaker

**TABLE 2B
ELECTRICAL DATA**

Model	PH12241	PH1230	PH1236	PH1236-B	PH1242	PH12481	PH12481-B
Electric Rating 60 Hz - Ckt A	230/208-60-1	230/208-60-1	230/208-60-1	230/208-60-3	230/208-60-1	230/208-60-1	230/208-60-3
Operating Voltage Range	197-253	197-253	197-253	187-253	197-253	197-253	187-253
Minimum Circuit Ampacity	17	21	26	19	30	33	25.4
BCSC	10.5	13.5	16.5	10.9	18	20.5	14.7
Field Wire Size *	12	10	10	12	10	8	8
Ground Wire Size	10	10	10	10	10	10	10
Delay Fuse - Max. **	25	30	40	25	45	50	35
Total Unit Amps - 203-208	12.9/13.9	15.6/17.1	19.4/21.2	14.7/15.6	23.5/24.5	25.5/27.5	19.0/20.3
Compressor - Circuit A							
Compressor Type	Scroll	Scroll	Scroll	Scroll	Scroll	Scroll	Scroll
Volts	230/208	230/208	230/208	230/208	230/208	230/208	230/208
Rated Load Amps	9.5/10.5	11.5/13.0	14.7/16.5	10/10.9	16.7/17.7	18.5/20.5	12.0/13.3
Lock Rotor Amps	54/54	72.5/72.5	88/88	77/77	104/104	137/137	91/91
Fan Motor and Condenser							
Fan Motor - HP/RPM	1/5 -1090	1/5 - 1075	1/5 - 1075	1/5 - 1075	1/3 - 825	1/3 - 825	1/3 - 825
Fan Motor Amps	1.2	1.4	1.4	1.4	2.5	2.5	2.5
Fan Dia/CFM	20"/1650	20"/2000	20"/2000	20"/2000	24"/3000	24"/3000	24"/3000
Motor and Evaporator							
Blower Motor - HP/RPM	1/3 Variable	1/2 Variabel	1/2 Variable	1/2 Variable	3/4 Variable	3/4 Variable	3/4 Variable
Blower Motor - Amps	2.2	2.7	3.3	3.3	4.3	4.5	4.5
CFM Cooling & ESP	800 @ 0.10	1000 @ 0.15	1000 @ 0.15	1000 @ 0.15	1400 @ 0.20	1550 @ 0.20	1550 @ 0.20
Charge (R22 oz.)	91	99	121	121	133	123	123
Shipping Weight (pounds)	320	335	345	345	420	440	440

* 75 degree C copper wire

** Maximum time delay fuse of HACR type circuit breaker

**TABLE 3
OPTIONAL FIELD INSTALLED HEATER PACKAGES
ONLY TO BE USED WITH THE HEAT PUMP MODELS INDICATED**

Heater Package Model	Volts and Phase	PH11242	PH12241	PH11301	PH1230	PH11361	PH11361-B	PH11361-C	PH1236	PH1236-B	
EH3PB-A05	240/208-1	S	NA	S	NA	S	A	A	NA	NA	This column has been left blank intentionally
EH3PB-A08	240/208-1	S	NA	S	NA	S	A	A	NA	NA	
EH3PB-A10	240/208-1	NA	NA	S ①	S	S ①	A ①	A ①	S	NA	
EH3PB-A15	240/208-1	NA	NA	S	NA	S	A	A	NA	NA	
EH3PC-A05	240/208-1	NA	S	NA	S	NA	NA	NA	S	NA	
EH3PC-A10	240/208-1	NA	S	NA	NA	NA	NA	NA	NA	NA	
EH3PC-A15	240/208-1	NA	NA	NA	S ②	NA	NA	NA	S ②	NA	
EH3PB-B09	240/208-3	NA	NA	A ①	NA	A ①	S ①	A ①	NA	S	
EH3PB-B15	240/208-3	NA	NA	A	NA	A	S	A	NA	S ③	
EH3PB-C09	480-3	NA	NA	A ①	NA	A ①	A ①	S ①	NA	NA	
EH3PB-C15	480-3	NA	NA	A	NA	A	A	S	NA	NA	
Heater Package Model	Volts and Phase	PH11422	PH1242	PH10481	PH10481-B	PH10481-C	PH12481	PH12481-B	PH1060	PH1060-B	
EH5PB-A05	240/208-1	S	S	S	A	A	S	NA	S	A	A
EH5PB-A10	240/208-1	S ①	S	S ①	A ①	A ①	S	NA	S ①	A ①	A ①
EH5PB-A15	240/208-1	S	S ②	S	A	A	S ②	NA	S	A	A
EH5PB-A20	240/208-1	NA	NA	S	A	A	NA	NA	S	A	A
EH5PB-B09	240/208-3	NA	NA	A ①	S ①	A ①	NA	S	A ①	S ①	A ①
EH5PB-B15	240/208-3	NA	NA	A	S	A	NA	S ③	A	S	A
EH5PB-B18	240/208-3	NA	NA	A	S	A	NA	NA	A	S	A
EH5PC-C09	480-3	NA	NA	A ①	A ①	S ①	NA	NA	A ①	A ①	S ①
EH5PC-C18	480-3	NA	NA	A	A	S	NA	NA	A	A	S

S=Standard application – heater voltage and phase same as basic unit.
A=Alternate application – heater voltage and phase different from basic unit.
NA=Not approved.

- ① Max. KW that can operate with Heat Pump on.
- ② Max. KW that can operator with Heat Pump on is 10 KW. 15 KW will operate during emergency heat.
- ③ Max. KW that can operate with Heat Pump on is 9KW. 15 KW will operate during emergency heat

**TABLE 4
OPTIONAL FIELD INSTALLED ELECTRIC HEATER TABLE**

Heater Pkg. Model No.	Unit Volts & Phases	Heater KW & Capacity @ 240 Volts		Heater KW & Capacity @ 208 Volts		240/208V Heater Amps	Heater Internal Fuse	Circuit B				
		KW	BTUH	KW	BTUH			No. Field Circuits	Min. Circuit Ampacity	① Max. Over Current Protection	② Field Power Wiring	③ Ground Wire Size
EH3PB-A05	240/208-1	5	17,100	3.75	12,800	20.8/18.1		1	26/23	30/25	10/10	10
EH3PB-A08	240/208-1	8	27,300	6.00	20,500	33.3/28.8		1	42/36	45/40	10/10	10
EH3PB-A10	240/208-1	10	34,100	7.50	26,000	41.6/36.2		1	53/46	60/50	6/8	10
EH3PB-A15	240/208-1	15	51,200	11.25	38,400	62.5/54.1	30/60	1	79/68	80/70	4/4	8
EH3PB-A08	240/208-1	5	17,100	3.75	12,800	20.8/18.1		1	26/23	30/25	10/10	10
EH3PC-A10	240/208-1	10	34,100	7.50	26,000	41.6/36.2		1	53/48	60/50	6/8	10
EH3PC-A15	240/208-1	15	51,200	11.25	38,400	62.5/54.1	30/60	1	79/68	80/70	4/4	8
EH5PB-A05	240/208-1	5	17,100	3.75	12,800	20.8/18.1		1	26/23	30/25	10/10	10
EH5PB-A10	240/208-1	10	34,100	7.50	26,000	41.6/36.2		1	53/46	60/50	6/8	10
EH5PB-A15	240/208-1	15	51,200	11.25	38,400	62.5/54.1	30/60	1	79/68	80/70	4/4	8
EH5PB-A20	240/208-1	20	68,200	15.00	51,200	83.2/72.1	60/60	1	104/91	110/100	2/3	6
EH3PB-B09	240/208-3	9	30,700	6.75	23,000	21.7/18.7		1	28/24	30/25	10/10	10
EH3PB-B15	240/208-3	15	51,200	11.25	38,400	36.2/31.2		1	46/39	50/40	8/8	10
EH5PB-B09	240/208-3	9	30,700	3.75	23,000	21.7/18.7		1	28/24	30/25	10/10	10
EH5PB-B15	240/208-3	15	51,200	11.25	38,400	36.2/31.2		1	46/39	50/40	8/8	10
EH5PB-B18	240/208-3	18	61,400	13.50	46,100	43.4/37.5		1	55/47	60/50	6/8	10
EH3PB-C09	480-3	9	30,700	8.26	28,200	10.8		1	15	15	14	14
EH3PB-C15	480-3	15	51,200	13.77	47,000	18.0		1	23	25	10	10
EH5PB-C09	480-3	9	30,700	8.26	28,200	10.8		1	15	15	14	14
EH5PB-C15	480-3	15	51,200	13.77	47,000	18.0		1	23	25	10	10
EH5PB-C18	480-3	18	61,400	16.53	56,400	21.7		1	28	30	10	10

- ① Time delay fuses of HACR type circuit breakers must be used for 60 and smaller sizes. Standard fuses or circuit breakers are suitable for sizes 70 and larger. 480V circuit breakers are not HACR type.
- ② Based on wire suitable for 75 degree C. Other wiring materials must be rated for marked Minimum Circuit Ampacity or greater.
- ③ Based upon Table 250-95 of N.E.C. 1993. See electric data for basic heat pump for Circuit A wiring specification requirements.

NOTE: While this electrical data is presented as a guide, it is important to electrically connect properly sized fuses and conductor wires in accordance with the national Electrical Code and all existing local codes.

**FIGURE 1
UNIT DIMENSIONAL DRAWING**

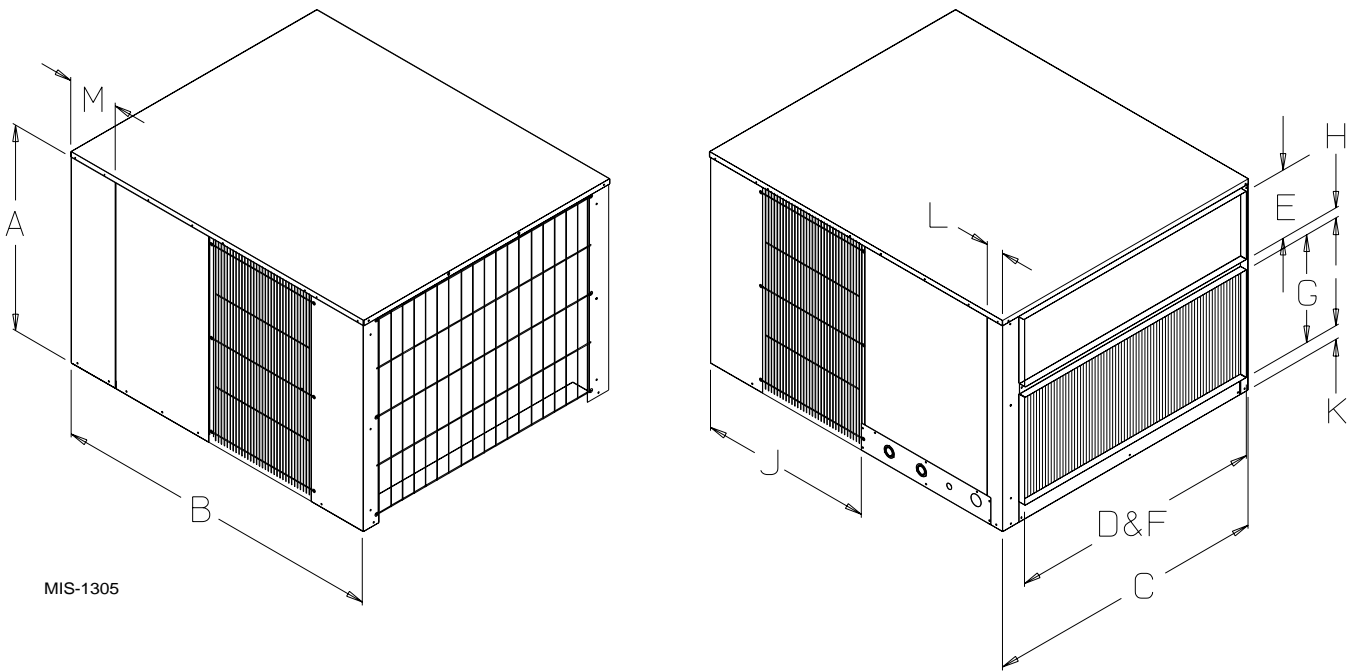

MIS-1305

**TABLE 5
DIMENSIONS OF UNIT**

Model No.	Nominal Cabinet Dimensions (Inches)							Duct Opening (Inches)				H
								Discharge		Return Air		
	A	B	C	J	K	L	M	D	E	F	G	
PH1124 PH1224 PH1130 PH1230 PH1136 PH1236	24-1/4	48-3/16	38-1/8	26-1/8	2-1/8	9/16	9/16	33	6	33	14	7/8
PH1142 PH1242 PH1148 PH1248 PH1060	31-1/4	50	42	26	3	2-3/4	7-9/16	38	10	38	16	1-3/8

LOCATION

GENERAL

The unit must be located outside, or in a well ventilated area. It must not be in the space being heated or cooled. A sound absorbing material should be considered if the unit is to be installed in such a position or location that might cause transmission of sound or vibration to the living area or adjacent buildings.

SLAB MOUNTING

In areas where winter temperatures *DO NOT* go below 32° F for periods over twelve hours, the unit may be slab mounted at grade level. When installing unit at grade level, install on a concrete slab at least four inches above finished grade level. Slab should have a slope tolerance away from the building structure of at least 1/4 inch per foot, while being level from side to side. This will prevent ice buildup under the unit during defrost cycles. Place slab in a location where runoff water from higher ground will not collect around unit. See Figure 2.

A minimum of 18 inches should be provided between the coil inlet and any building surfaces. Provide at least four feet between coil outlet and any building wall, fences or other vertical structures. Provide a minimum of three feet clearance on the service access side of the unit. See Figure 3

ROOF MOUNTING

When a unit is installed in areas where low ambient temperatures or strong winter winds exist, it should be placed so prevailing winter winds are not in direct line with the heat pump coil. If this is not possible, a wind barrier should be constructed. Place barrier 24 inches from the coil inlet side of the unit and in the direction of prevailing winds. Size barrier at least the same height and width as the unit. This may be necessary on ground level installations, also. See Figure 4.

WINTER INSTALLATION BELOW 32°F

In areas where winter conditions go below 32°F for extended periods, the unit must be elevated above the mounting surface to prevent snowfall or defrost ice accumulation from interfering with the operation of the unit. A minimum of twelve inch elevation is recommended, while greater elevation may be required for areas of high snow accumulation. Poured concrete, steel framework, brick, cement block, etc., can be utilized to construct a suitable raised mounting platform. See Figure 5.

TYPICAL INSTALLATIONS

1. **ROOF MOUNTED** – The unit is mounted on a sturdy base on the roof of the building. Return air to the unit is brought through a single return grille (grilles with built-in filters are best since they enable easy access for filter changing). Return air ducts are attached to the lower section of the front panel. Supply air is brought from the unit to attic duct work or to a furred down hall. Supply air duct is attached to the top of the front panel.

CAUTION: All outdoor duct work must be thoroughly insulated and weatherproofed. All attic duct work must be thoroughly insulated. Two inch thick insulation with suitable vapor barrier is recommended for both outdoor and attic runs.

In roof top installation, as in all installations, the heat pump must be level from side to side. However, the unit should have a pitch along the length to assure complete external drainage of precipitation and of defrost condensate. See Figures 6 and 7, and Tables 6 and 7.

2. **CRAWL SPACE** – Duct work installed in crawl space must be well insulated and provided with a vapor barrier. In addition, the crawl space must be thoroughly ventilated and provided with a good vapor barrier as a ground cover. It is most desirable to install the unit outdoors rather than inside the crawl space, so that it will be readily accessible for service. In addition, it is necessary to dispose of the condensate from the outdoor coil on the heating cycle, and this is virtually impossible with the unit installed inside the crawl space.
3. **SLAB MOUNTED AT GROUND LEVEL** – This type installation is ideal for homes with a slab floor construction where a roof mounted unit is not desired. The supply and return duct work can be run through a furred closet space.
4. **THROUGH THE WALL** – This type installation requires a suitable framework to be fabricated capable of withstanding the unit weight. Normally the unit will be insulated so as to minimize supply and return duct work.

**FIGURE 2
SLAB MOUNTING AT GROUND LEVEL
(Above 32°F Outside Temperature)**

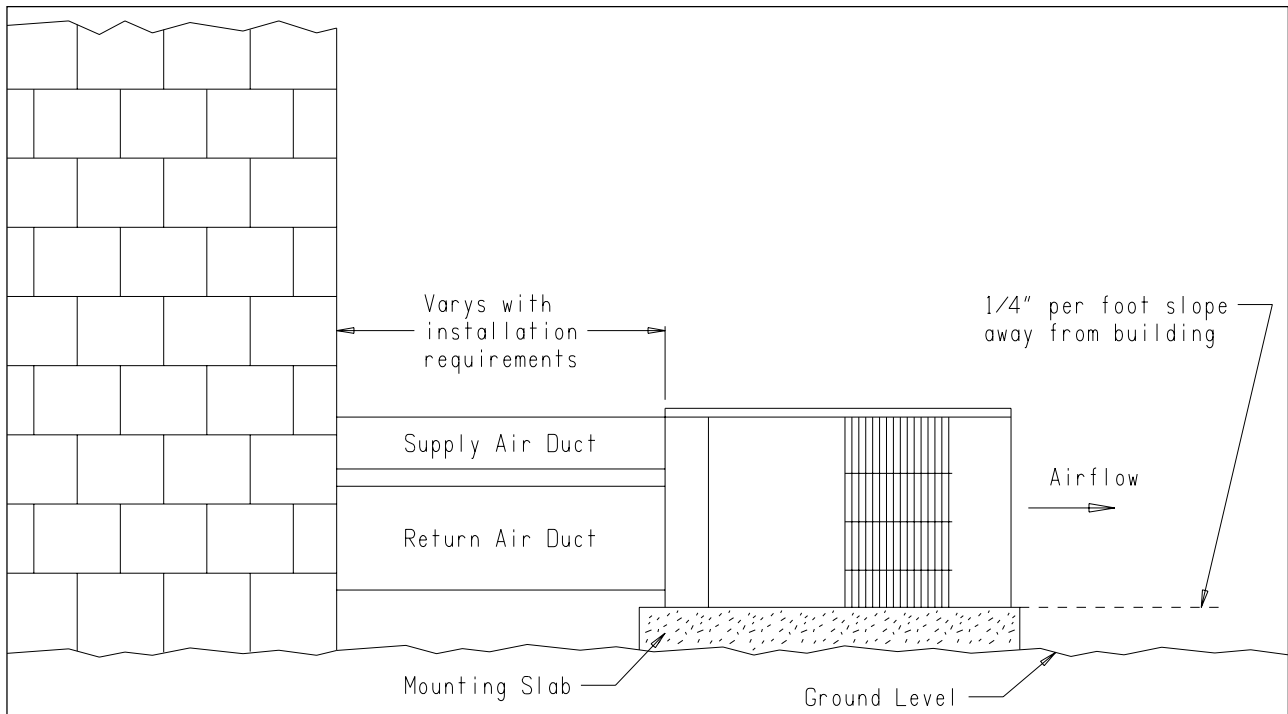

**FIGURE 3
AIRFLOW AND SERVICE ACCESS CLEARANCES**

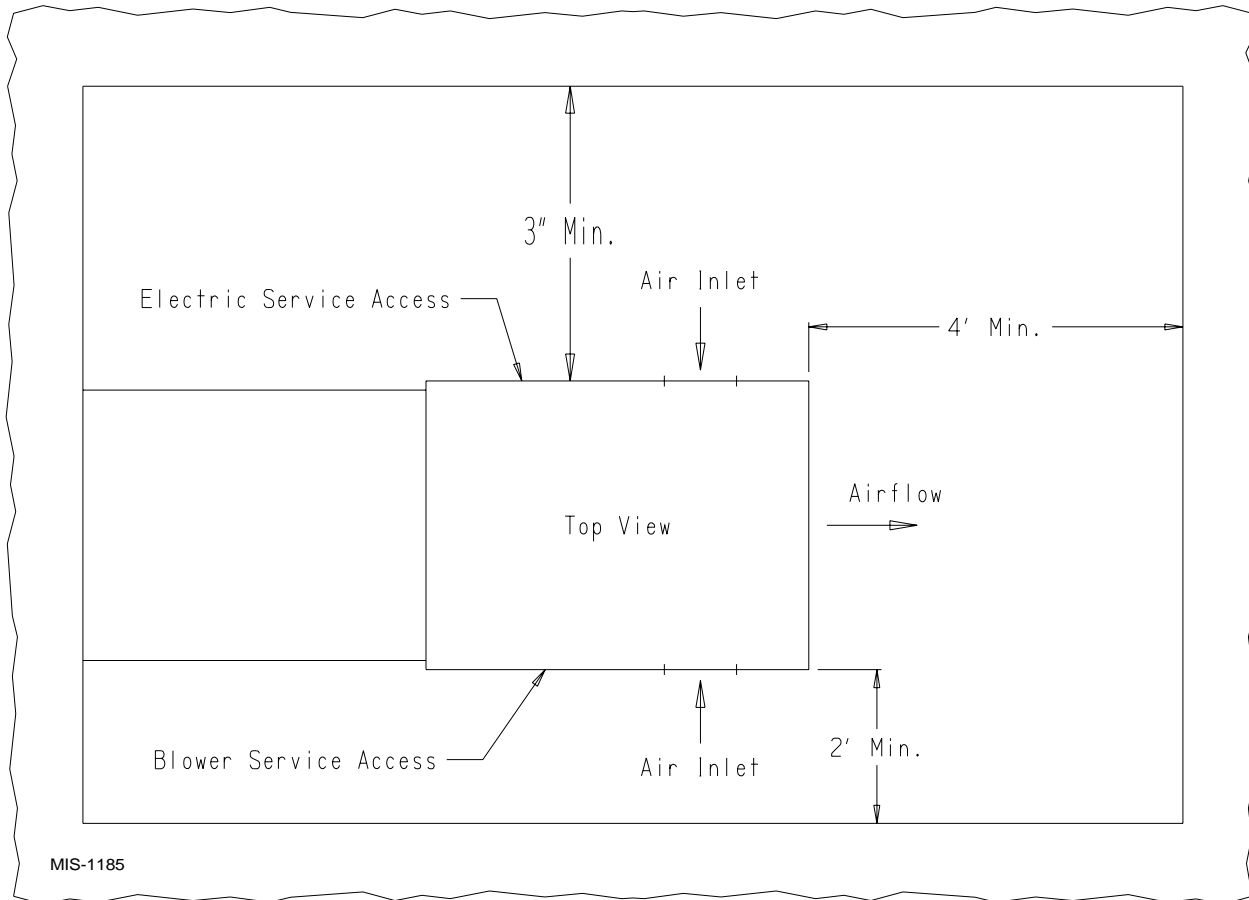

MIS-1185

FIGURE 4
ROOF TOP APPLICATION
 (May also be required for ground level installations)

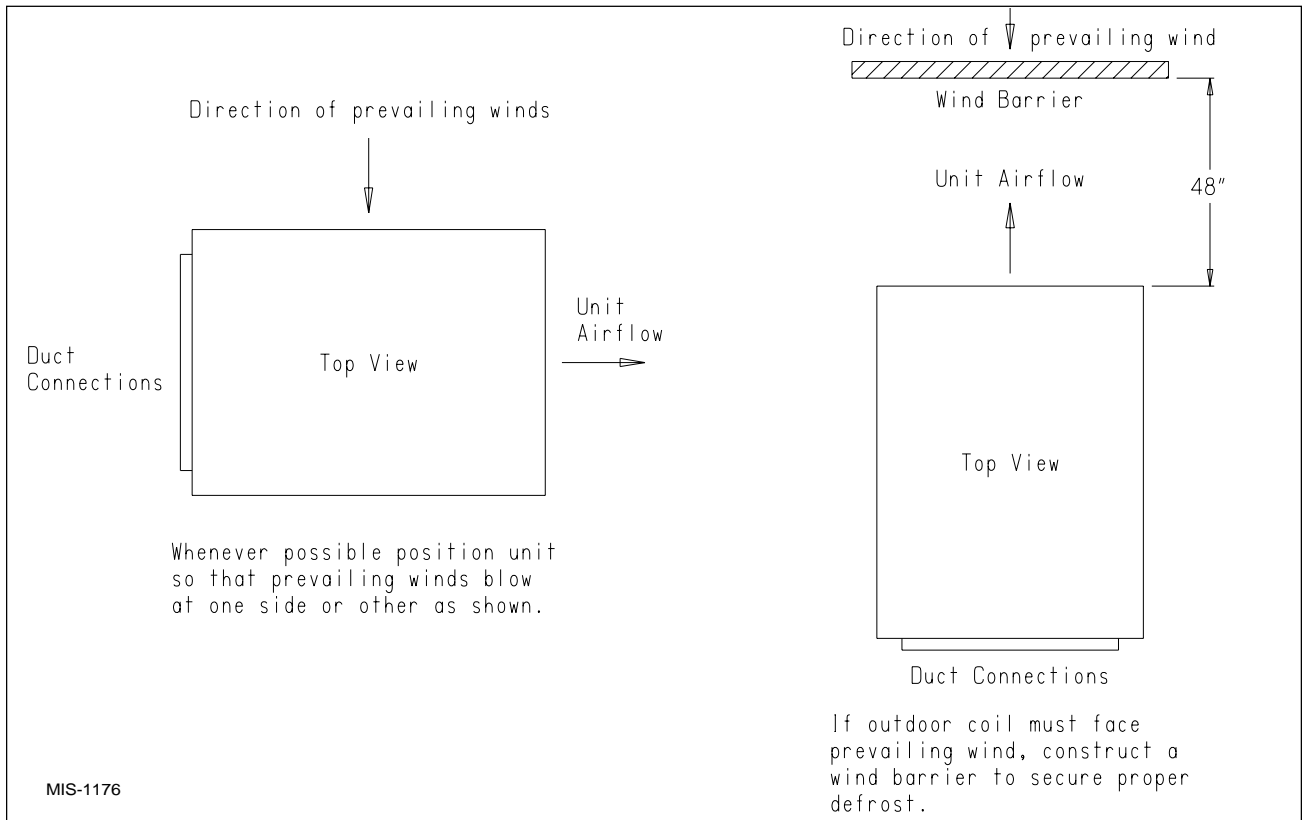

FIGURE 5
ELEVATED MOUNTING PLATFORMS

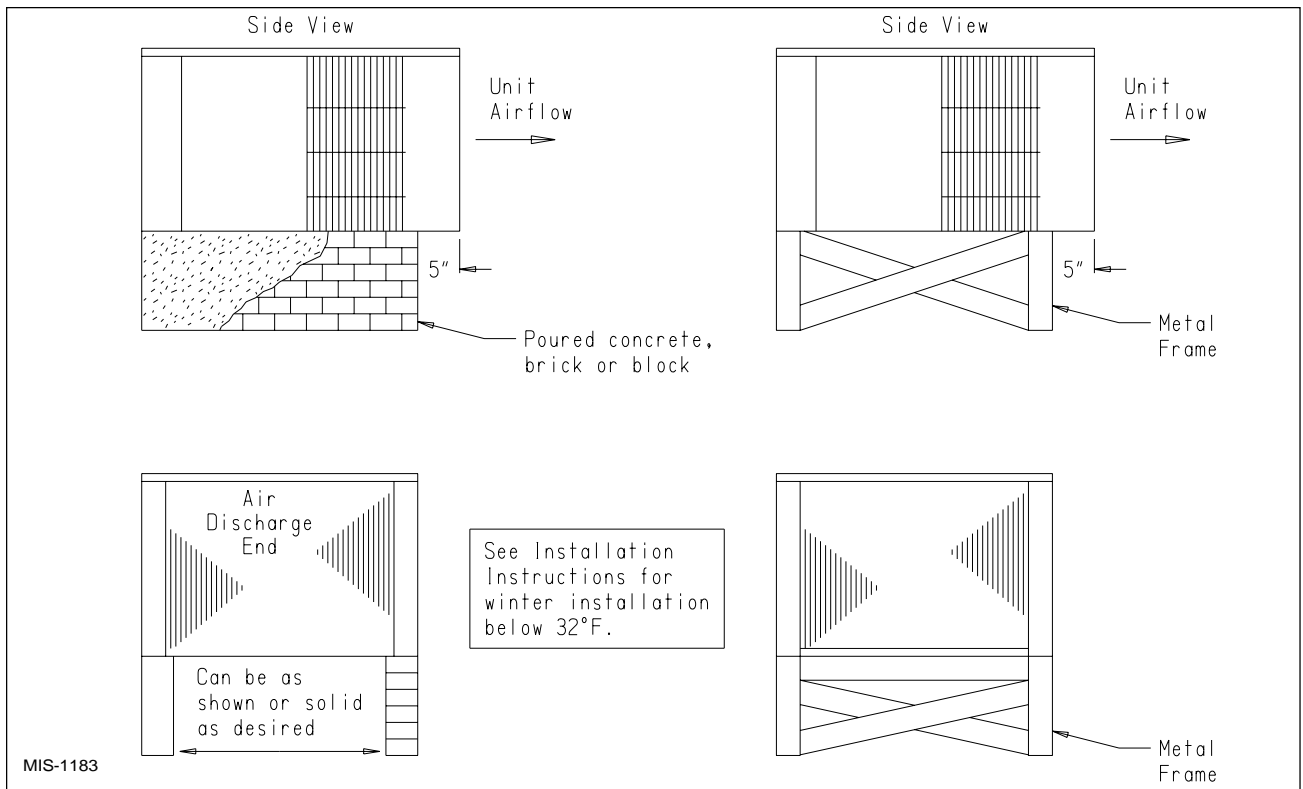

FIGURE 6
PREFABRICATED ROOF CURB SPECIFICATIONS
HEAVY GAUGE GALVANIZED WITH WOOD NAILING STRIP, WELDED/LEAKPROOF
ONE PIECE CONSTRUCTION – READY TO INSTALL

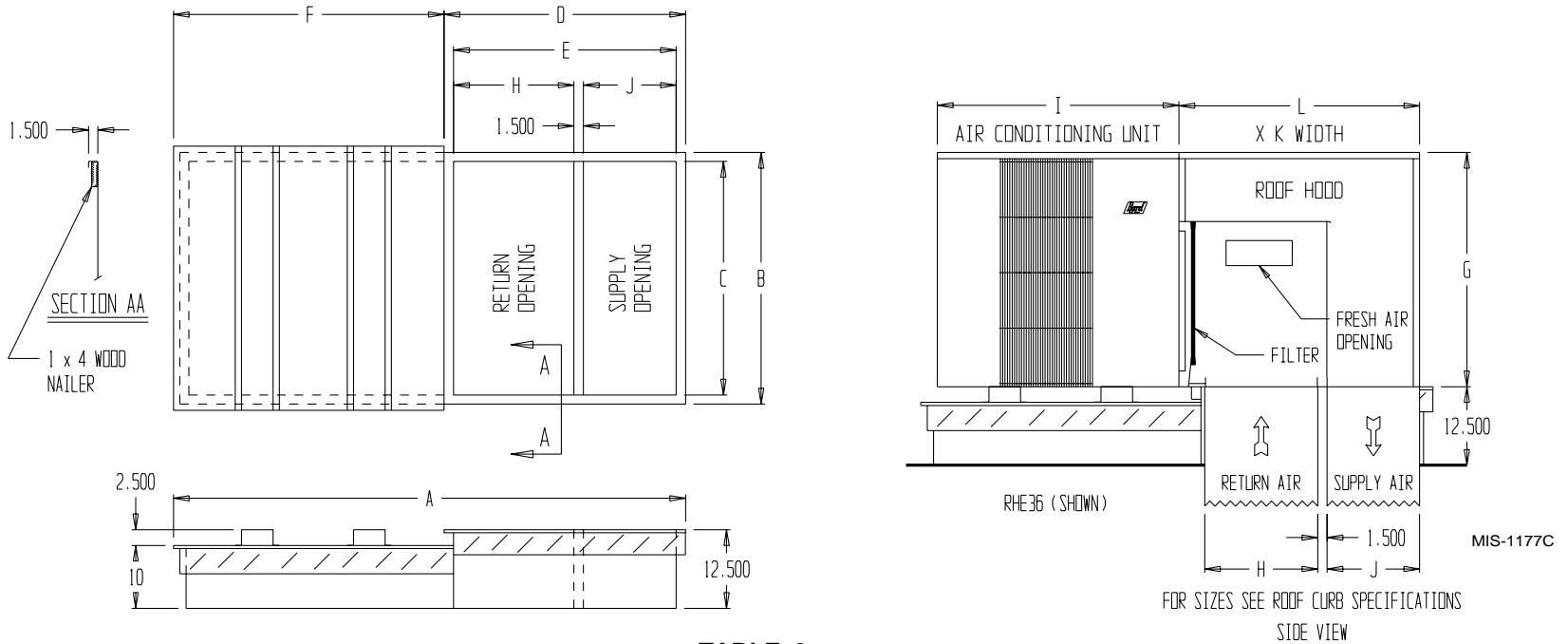
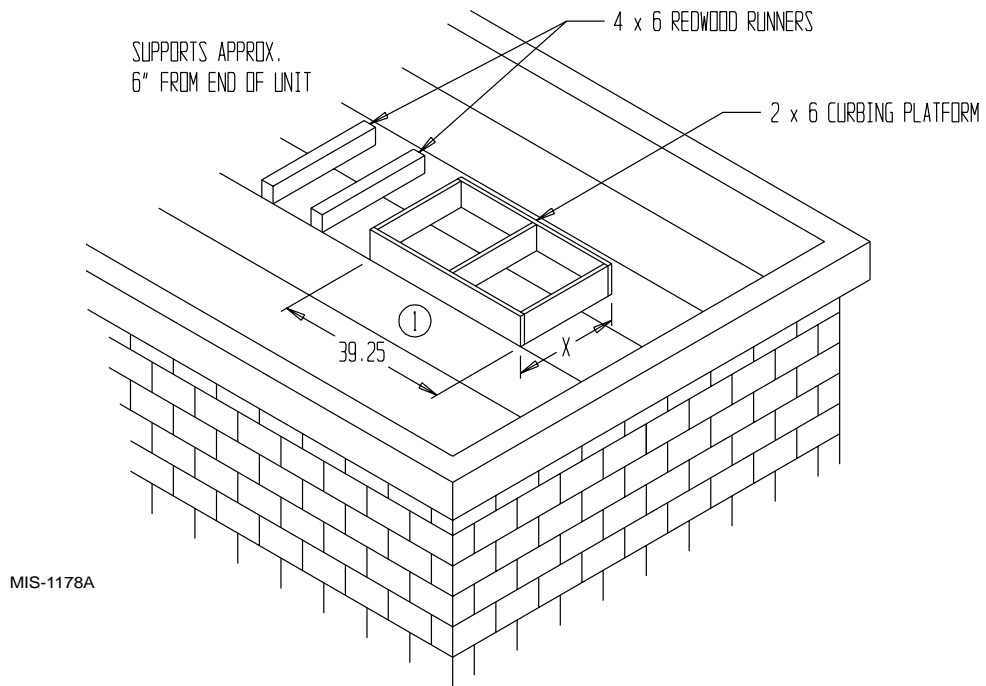

TABLE 6
ROOF CURB DIMENSIONS

Unit Model	Roof Hood Model	Roof Curb Model	Roof Curb Details											
			A	B	C	D	E	F	G	H	I	J	K	L
PH1124* PH1224* PH1130* PH1230* PH1136* PH1236*	RHE-36	9042-003	80.375	40.25	37.25	38.375	35.375	42	24.25	19.125	48.188	14.75	38.125	38.25
PH1142* PH1242* PH1048* PH1248* PH1060*	RHE-60	9042-004	82.375	44.125	41.125	38.375	35.375	44	31.25	19.125	50	14.75	42	38.25

* Revision Level

**FIGURE 7
FIELD FABRICATED CURBING**



- ① A separate metal flashing should be installed around wood curbing. Caulk & seal all joints & weatherproof.

**TABLE 7
DIMENSION "X" FOR FIELD
FABRICATED CURBING**

Unit Model	Roof Hood Model	Dimension X
PH1124 PH1224 PH1130 PH1230 PH1136 PH1236	RHE-36	41
PH1142 PH1242 PH1048 PH1248 PH1060	RHE60	44-7/8

5. **OTHER INSTALLATIONS** – Many other installations are possible with the packaged heat pump. No matter what the installation, always consider the following facts:

- A. Insure that the discharge air is not obstructed in any way so as to cause operation difficulties.
- B. The indoor coil drain pan is equipped with a coupling that must be piped through a condensate drain trap to a suitable drain.
- C. Always mount the unit in such a position that it may be easily reached for servicing and maintenance.
- D. Insure that the unit is clear so that proper air flow over the outdoor coil will be maintained.

If this unit is operated in cooling below a 65° outdoor ambient temperature, the installation of low ambient controls (CMA-6) to unit is required.

CONDENSATE DRAIN TRAP

It is very important to provide a trap in the condensate drain line to allow a positive liquid seal in the line and assure correct drainage from the coil condensate pan.

Install condensate drain trap shown in Figure 8. Use drain connection size or larger. Do not operate unit without trap. Unit must be level or slightly inclined toward drain.

With a trap installed on a unit located in an unconditioned area, water in the trap may freeze. It is recommended that the trap material be of a type that will allow for expansion of water when it freezes.

AIR FILTERS

Air filters for the return air side of the system are not provided as part of the various types of applications for these models, and must be field supplied and installed as part of the final installation.

Prior thought should be given to return air location and placement of the air filter(s). The air filter(s) must be of adequate size and readily accessible to the operator of the equipment. Filters must be adequate in size and properly maintained for proper operation. If this is not done, excessive energy use, poor performance, and multiple service problems will result. *It is impossible to oversize air filters.* Generous sizing will result in cleaner air and coils as well as lower operating costs and extend the time between required changes. Table 8 shows minimum filter areas and recommended filter sizes. Actual filter sizes can vary with the installation due to single or multiple returns utilizing a filter/grille arrangement or being placed immediately ahead of the indoor coil face in the return air duct.

**TABLE 8
FILTERS REQUIRED AND SIZE**

Model No.	Minimum Filter Area	Recommended Size
PH1124 PH1224 PH1130 PH1230 PH1136 PH1236	462 Square Inches (3.21 Square Feet)	15 x 30-5/8 x 1
PH1142 PH1242 PH1048 PH1248 PH1060	608 Square Inches (4.62 Square Feet)	(2) 16 x 20 x 1

NOTE: If roof hood accessory is to be used, information on air filters may be found under that heading in this manual. Air filters are supplied as part of that package.

**FIGURE 8
CONDENSATE DRAIN TRAP**

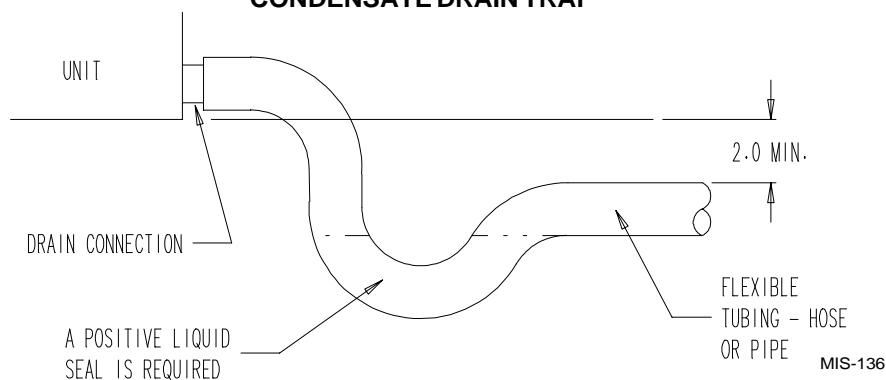

WIRING – MAIN POWER

Refer to the unit rating plate for wire sizing information and maximum fuse size. Each outdoor unit is marked with a “Minimum Circuit Ampacity”. This means that the field wiring used must be sized to carry that amount of current. If field installed heaters are added to the basic unit, a second separate power supply circuit will be required. The heater rating plate located adjacent to the basic unit rating plate will show the appropriate circuit ampacity fuse size, etc. (Also see “Electrical Data” on pages 3, 4 and 5.) *All models are suitable for connection with copper wire only.* These instructions **must** be adhered to. Refer to the National Electrical Code for complete current carrying capacity data on the various insulation grades of wiring material.

The unit rating plate lists a “Maximum Time Delay Fuse” or “HACR” type circuit breaker that is to be used with the equipment. The correct size must be used for proper circuit protection and also to assure that there will be no nuisance tripping due to the momentary high starting current of the compressor.

WIRING – 24V LOW VOLTAGE CONTROL CIRCUIT

Ten (10) wires should be run from thermostat subbase to the 24V terminal board in the unit. A nine conductor, 18 gauge copper, color-coded thermostat cable is recommended. The connection points are shown in Figure 9.

**FIGURE 9
LOW VOLTAGE WIRING**

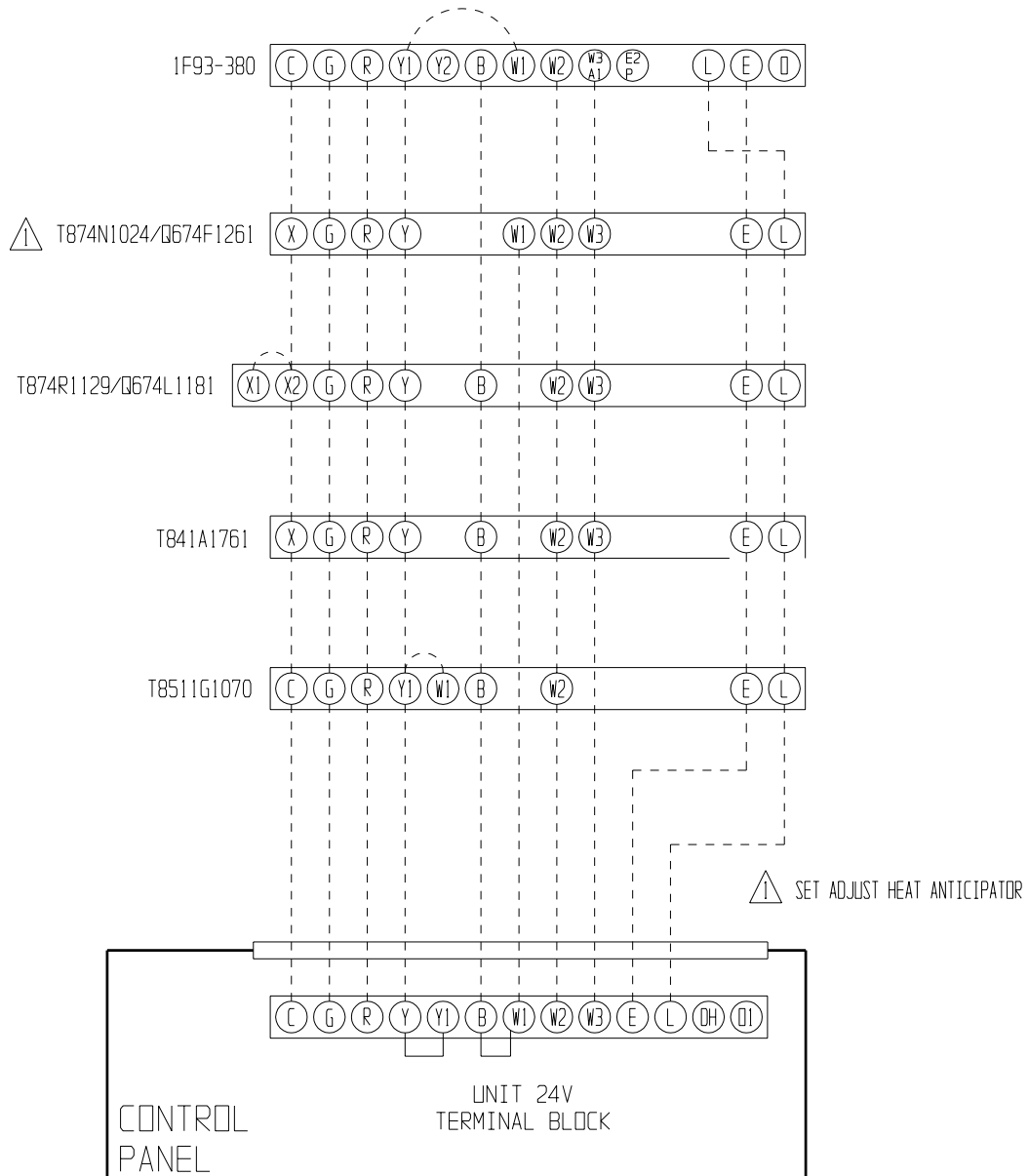

MIS-1187A

THERMOSTATS

See specific wiring information for the different models, heater KWs, and voltages.

**TABLE 9
HEAT PUMP THERMOSTATS**

THERMOSTAT	SUBBASE	DESCRIPTION
8403-045 (T841A1761)	Part of Thermostat	1 stage cool, 2 stage heat; Mercury bulb; Manual changeover Fan Switch: Auto-On; System Switch: Em Heat-Heat-Off-Cool Indicating Lamps: Check-Em Heat-Aux Heat
8403-017 (T874R1129)	8404-009 Q674L1181	1 stage cool, 2 stage heat; Mercury bulb; Manual changeover Fan Switch: Auto-On; System Switch: Em Heat-Heat-Off-Cool Indicating Lamps: Check-Em Heat ①
8403-018 (T874N1024)	8404-010 Q674F1261	1 stage cool, 2 stage heat; Mercury bulb; Auto changeover Fan Switch: Auto-On; System Switch: Off-Em Heat-Heat-Auto-Cool Indicating Lamps: Check-Em Heat ②
8403-042 (T8511G1070)	Part of Thermostat	1 stage cool, 2 stage heat; Digital non-programmable (no battery required) Automatic or manual changeover Fan Switch: Auto-On; System Switch: Off-Em Heat-Auto or Cool/Heat Indicating Lamps: Check Display Indication: Em Heat-Aux Heat
8403-049 (1F93-380)	Part of Thermostat	2 stage cool, 2 stage heat; Digital programmable (7 day); Automatic or manual changeover; 1 set-up/set-back period per 24 hours Programmable ventilation terminal for economizer or energy recovery Fan Switch: Auto-On; System Switch: Off-Em Heat-Auto or Cool/Heat Indicating Lamps: Emer-Pump-Malf-Aux

- ① No automatic changeover position – must be manually placed in heat or cool. Reversing valve remains energized at all times system switch is in heat position (except during defrost cycle). No pressure equalization noise when thermostat is satisfied on either heating or cooling.
- ② Allows thermostat to control both heating and cooling operation when set in “AUTO” position. Reversing valve de-energizes at end of each “ON” heating cycle.

IMPORTANT NOTE: Only the thermostat and subbase combinations as shown above will work with this equipment. The thermostat and subbase **MUST** be matched, and correct operation can be assured only by proper selection and application of these parts. The above combinations incorporate the following features: Man-Auto fan switch, Off-Heat-Cool-Em. Heat Switch, and two (2) indicator lamps - one for emergency heat and one for compressor malfunction.

**TABLE 10
THERMOSTAT WIRE SIZE**

Transformer VA	FLA	Wire Gauge	Maximum Distance in Feet
55	2.3	20	45
		18	60
		16	100
		14	160
		12	250

THERMOSTAT INDICATOR LAMPS

The red lamp marked “EM. HT.” comes on and stays on whenever the system switch is placed in Em. Ht. position. The green lamp marked “Check” will come on if there is any problem that prevents the compressor from running when it is supposed to be.

EMERGENCY HEAT POSITION

The operator of the equipment must manually place the system switch in this position. This is done when there is a known problem with the outdoor section, or when the green “Check” lamp comes on indicating a problem.

TRANSFORMER TAPS

230/208V, 1 phase and 3 phase equipment employ dual primary voltage transformers. All equipment leaves the factory wired on 240V tap. For 208V operation, reconnect from 240V to 208V tap. The acceptable operating voltage range for the 240 and 208V taps are:

TAP	RANGE
240	253 – 216
208	220 – 187

NOTE: The voltage should be measured at the field power connection point in the unit and while the unit is operating at full load (maximum amperage operating condition).

COMPRESSOR CUTOFF THERMOSTAT and OUTDOOR THERMOSTAT WIRING

Heat pump compressor operation at outdoor temperatures below 0° F are neither desirable nor advantageous in terms of efficiency. Since most equipment at time of manufacture is not designated for any specific destination of the country and most of the equipment is installed in areas not approaching the lower outdoor temperature range, the compressor cutoffs are not factory installed.

Outdoor thermostats are available to hold off various banks of electric heat until needed as determined by outdoor temperature. The set point of either type of thermostat is variable with geographic region and sizing of the heating equipment to the structure. Utilization of the Heating Application Data and the heat loss calculation of the building are useful in determining the correct set points. Refer to Installation Instructions of CMH-14 Outdoor Thermostat Kit for more information.

FIGURE 10
UNIT 24V TERMINAL BOARD (5 THRU 10 KW)

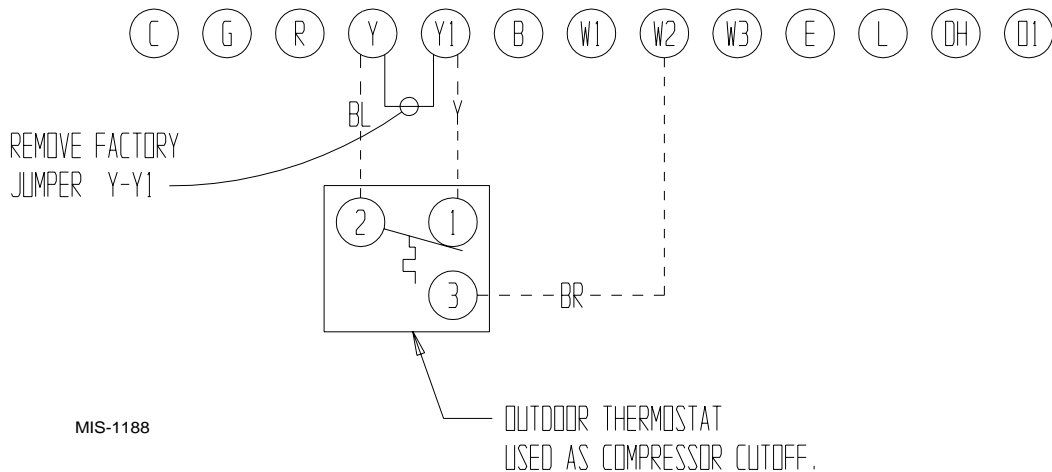

COMPRESSOR CUTOFF THERMOSTAT WIRING (5 thru 10 KW) (FIGURE 10)

COMPRESSOR CUTOFF THERMOSTAT WIRING (15 thru 20 KW) (FIGURE 11)

**TABLE 11
5 thru 10 KW**

Model	KW	Volts	Phase
PH11242	0,5,8	230	1
PH12241	0,5,10	230	1
PH11301	0,5,8	230	1
PH1230	0,5,10	230	1
PH11361	0,5,8	230	1
PH1236	0,5,10	230	1
PH11422	0,5,10	230	1
PH1242	0,5,10	230	1
PH10481	0,5,10	230	1
Ph10481-B, -C	0,9	230 / 460	3
PH12481	0,5,10	230	1
PH12481-B	0,9	230	3
PH1060	0,5,10	230	1
PH1060-B, -C	0,9	230 / 460	3

**TABLE 12
15 THRU 20 KW**

Model	KW	Volts	Phase
PH11242	15	230	1
PH12241	15	230	1
PH11301	15	230	1
PH1230	15	230	1
PH11361	15	230	1
PH1236	15	230	1
PH11422	15,20	230	1
PH1242	15	230	1
PH10481	15,20	230	1
PH10481-B, -C	15,18	230 / 460	3
PH12481	15	230	1
PH12481-B	15	230	1
PH1060	15,20	230	1
PH1060-B, -C	15,18	230 / 460	3

**FIGURE 11
UNIT 24V TERMINAL BOARD (15 THRU 20 KW)**

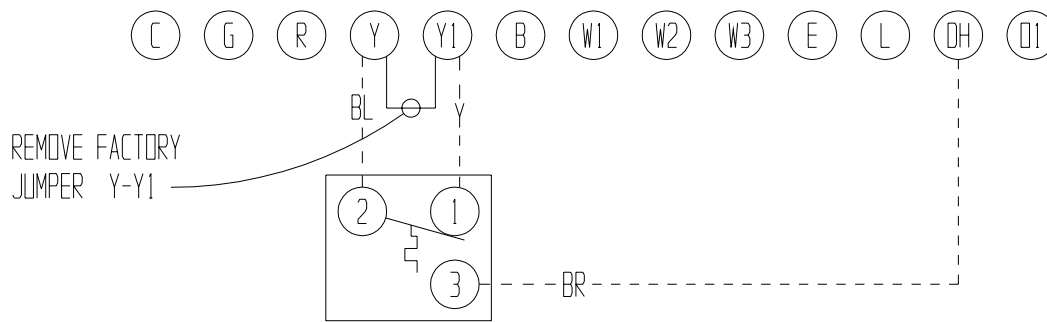

MIS-1189

OUTDOOR THERMOSTAT
USED AS COMPRESSOR CUTOFF.

THREE PHASE SCROLL COMPRESSOR START UP INFORMATION

Scroll compressors, like several other types of compressors, will only compress in one rotational direction. Direction of rotation is not an issue with single phase compressors since they will always start and run in the proper direction.

However, three phase compressors will rotate in either direction depending upon phasing of the power. Since there is a 50-50 chance of connecting power in such a way as to cause rotation in the reverse direction, verification of proper rotation must be made. Verification of proper rotation direction is made by observing that suction pressure drops and discharge pressure rises when the compressor is energized. Reverse rotation also results in an elevated sound level over that with correct rotation, as well as, substantially reduced current draw compared to tabulated values.

Verification of proper rotation must be made at the time the equipment is put into service. If improper rotation is corrected at this time there will be no negative impact on the durability of the compressor. However, reverse operation for over one hour may have a negative impact on the bearing due to oil pump out.

NOTE: If compressor is allowed to run in reverse rotation for several minutes the compressor's internal protector will trip.

All three phase ZR*3 compressors are wired identically internally. As a result, once the correct phasing is determined for a specific system or installation, connecting properly phased power leads to the same Fusite terminals should maintain proper rotation direction.

The direction of rotation of the motor may be changed by reversing any two line connections to the unit.

SEQUENCE OF OPERATION

COOLING – Circuit R-Y makes at thermostat pulling in compressor contactor starting the compressor and outdoor motor. The G (indoor motor) circuit is automatically completed on any call for cooling operation, or can be energized by manual fan switch on subbase for constant air circulation.

HEATING – A 24V solenoid coil on reversing valve controls heating cycle operation. Two thermostat options, one allowing “AUTO” changeover from cycle to cycle and the other constantly energizing solenoid coil during heating season and thus eliminating pressure equalization noise except during defrost, are to be used. On “AUTO” option, a circuit is completed from R-W1 and R-Y on each heating “On” cycle energizing reversing valve solenoid and pulling in compressor contactor starting compressor and outdoor motor. R-G also make starting indoor blower motor. Heat pump heating cycle now in operation. The second energizes the reversing valve solenoid constantly whenever the system switch on subbase is placed in “Heat” position, the “B” terminal being constantly energized from R. A thermostat demand for heat completes R-Y circuit, pulling in compressor contactor starting compressor and outdoor motor. R-G also make starting indoor blower motor.

DEFROST CYCLE

The defrost cycle is controlled by temperature and time on the solid state heat pump control. See Figure 12.

When the outdoor temperature is in the lower 40° F temperature range or colder, the outdoor coil temperature is 32° F or below. This coil temperature is sensed by the coil sensor mounted near the bottom of the outdoor coil. Once coil temperature reaches 30° F or below, the coil sends a signal to the control logic of the heat pump control and the defrost timer will start.

After 30 minutes at 30° F or below, the heat pump control will place the system in the defrost mode.

During the defrost mode, the refrigerant cycle switches back to the cooling cycle, the outdoor motor stops, electric heaters are energized, and hot gas passing through the outdoor coil melts any accumulated frost. When the temperature rises to approximately 57° F the coil sensor will send a signal to the heat pump control which will return the system to heating operations automatically.

If some abnormal or temporary condition such as a high wind causes the heat pump to have a prolonged defrost cycle, the heat pump control will restore the system to heating operation automatically after 10 minutes.

There are three settings on the heat pump control – 30 minute, 60 minute and 90 minute. Models are shipped wired on the 60 minute setting for greatest operating economy. If special circumstances require a change to another time, remove wire connected to terminal 60 and reconnect to desired terminal. Refer to Figure 12. The manufacturer's recommendation is for 60 minute defrost cycles.

**FIGURE 12
HEAT PUMP CONTROL BOARD**

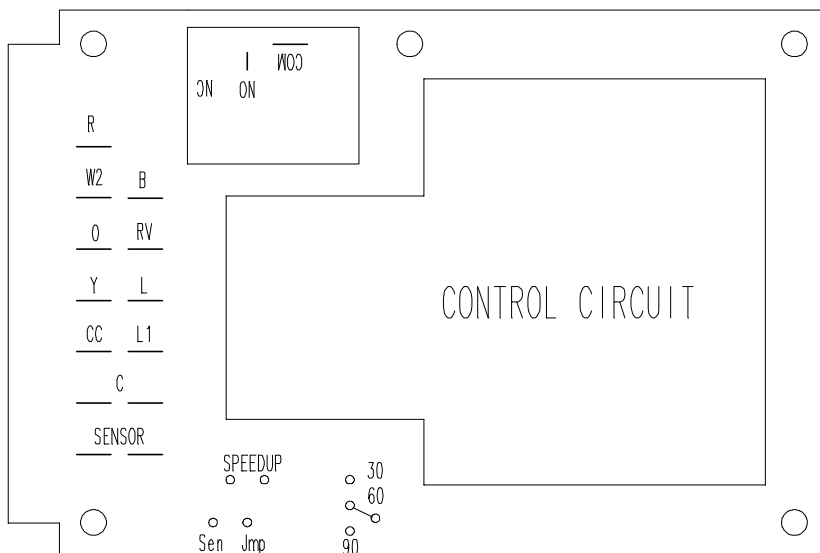

MIS-1191

There is a cycle speed up jumper on the control. This can be used to reduce the time between defrost cycle operation without waiting for time to elapse.

Use a small screwdriver or other metallic object, or another 1/4 inch QC to short between the *SPEEDUP* terminals to accelerate the HPC timer and initiate defrost.

Be careful not to touch any other terminals with instrument used to short the *SPEEDUP* terminals. It may take up to 10 seconds with the *SPEEDUP* terminals shorted for the speedup to be completed and the defrost cycle to start.

As soon as the defrost cycle kicks in remove the shorting instrument from the *SPEEDUP* terminals. Otherwise the timing will remain accelerated and run through the 1 minute maximum defrost length sequence in a matter of seconds and will automatically terminate the defrost sequence.

There is an initiate defrost jumper (sen jump) on the control that can be used at any outdoor ambient during the heating cycle to simulate a 0° coil temperature. This can be used to check defrost operation of the unit without waiting for the outdoor ambient to fall into the defrost region.

By placing a jumper across the *SEN JMP* terminals (a 1/4 inch QC terminal works best) the defrost sensor mounted on the outdoor coils is shunted out and will activate the timing circuit. This permits the defrost cycle to be checked out in warmer weather conditions without the outdoor temperature having to fall into the defrost region.

In order to terminate the defrost test in the *SEN JMP* jumper must be removed. If left in place too long the compressor could stop due to the high pressure control opening because of the high pressure condition created by operating in the cooling mode with outdoor fan off. Pressure will rise fairly fast as there is likely no actual frost on the outdoor coil in this artificial test condition

There is also a 5 minute compressor time delay function built into the HPC. This is to protect the compressor from instances it is helpful to the service technician to override or speed up this timing period, and shorting out the speedup terminals for a few seconds can do this.

TROUBLESHOOTING

SOLID STATE HEAT PUMP CONTROL TROUBLESHOOTING PROCEDURE

1. Turn on AC power supply to indoor and outdoor units.
2. Turn thermostat blower switch to fan on. The indoor blower should start. (If it doesn't, troubleshoot indoor unit and correct problem.)
3. Turn thermostat blower switch to Auto position. Indoor blower should stop.

4. Set system switch to heat or cool. Adjust thermostat to call for heat or cool. The indoor blower, compressor, and outdoor fan should start.

NOTE: If there is no power to 24 volt transformer, the compressor and outdoor fan motor will not start for 5 minutes. This is because of the compressor short cycle protection.

TROUBLESHOOTING

SYMPTOM	POSSIBLE CAUSES	WHAT TO CHECK	HOW TO CHECK OR REPAIR
Compressor contactor does not energize (cooling or heating)	Control circuit wiring	Check for R connection at unit, and 24V between R-C	Run R connection to outdoor unit to power heat pump control
	Compressor lock out	1. Check for 24V between L1-C on heat pump control 2. Check across high pressure switch.	1. If no voltage between L-C turn thermostat off and on again to reset high pressure switch. 2. If high pressure switch is open and will not reset, replace high pressure switch.
	Compressor short cycle protection	Check for 24V between CC-C and Y-C on heat pump control	If no voltage between CC-C, jumper speed up terminal and within 10 seconds power should appear between CC-C. Remove speed up jumper after 10 seconds
	Heat pump control defective	Check all other possible causes. Manual 2100-065	Replace heat pump control
	Contactor defective	Check for open or shorted coil winding	Replace contactor
Fan outdoor motor does not run (cooling or heating except during defrost)	Motor defective	Check for open or shorted motor winding	Replace motor
	Motor capacitor defective	Check capacitor rating. Check for open or shorted capacitor.	Replace capacitor
	Heat pump control defective	Check across fan relay on heat pump control (Com-NC)	Replace heat pump control
Reversing valve does not energize (heating only)	Reversing valve solenoid coil defective	Check for open or shorted coil	Replace solenoid coil
	Heat pump control defective	Check for 24V between RV-C and B-C	1. Check control circuit wiring 2. Replace heat pump control
Unit will not go into defrost (heating only)	Temperature sensor or heat pump control defective	Disconnect temperature sensor from board and jumper across speed up terminals and sen jump terminals. This should cause the unit to go through a defrost cycle within one minute.	1. If unit goes through defrost cycle, replace temperature sensor 2. If unit does not go through defrost cycle, replace heat pump control.
Unit will not come out of defrost (heating only)	Temperature sensor or heat pump control defective	Jumper across speed up terminals. This should cause the unit to come out of defrost within one minute.	1. If unit comes out of defrost cycle, replace temperature sensor. 2. If unit does not come out of defrost cycle, replace heat pump control.

CHECKING TEMPERATURE SENSOR CHECK OUT

1. Disconnect temperature sensor from board and from outdoor coil.
2. Use an ohmmeter and measure the resistance of the sensor. Also use ohmmeter to check for short or open.
3. Check resistance reading to chart of resistance; use sensor ambient temperature. (Tolerance of part is $\pm 10\%$.)
4. If sensor resistance reads very low, then sensor is shorted and will not allow proper operation of the heat pump control.
5. If sensor is out of tolerance, shorted, open, or reads very low ohms then it should be replaced.

TEMPERATURE F VS RESISTANCE R OF TEMPERATURE SENSOR

F	R	F	R	F	R	F	R
-25.0	196871	13.0	56985	53.0	19374	89.0	7507
-24.0	190099	14.0	55284	52.0	18867	90.0	7334
-23.0	183585	15.0	53640	53.0	18375	91.0	7165
-22.0	177318	16.0	52051	54.0	17989	92.0	7000
-21.0	171289	17.0	50514	55.0	17434	93.0	6840
-20.0	165487	18.0	49028	56.0	16984	94.0	6683
-19.0	159904	19.0	47590	57.0	16547	95.0	6531
-18.0	154529	20.0	46200	58.0	16122	96.0	6383
-17.0	149355	21.0	44855	59.0	15710	97.0	6239
-16.0	144374	22.0	43554	60.0	15310	98.0	6098
-15.0	139576	23.0	42295	61.0	14921	99.0	5961
-14.0	134956	24.0	41077	62.0	14544	100.0	5827
-13.0	130506	25.0	39898	63.0	14177	101.0	5697
-12.0	126219	26.0	38757	64.0	13820	102.0	5570
-11.0	122089	27.0	37652	65.0	13474	103.0	5446
-10.0	118108	28.0	36583	66.0	13137	104.0	5326
-9.0	114272	29.0	35548	67.0	12810	105.0	5208
-8.0	110575	30.0	34545	68.0	12492	106.0	5094
-7.0	107010	31.0	33574	69.0	12183	107.0	4982
-6.0	103574	32.0	32634	70.0	11883	108.0	4873
-5.0	100260	33.0	31723	71.0	11591	109.0	4767
-4.0	97064	34.0	30840	72.0	11307	110.0	4663
-3.0	93981	35.0	29986	73.0	11031	111.0	4562
-2.0	91008	36.0	29157	74.0	10762	112.0	4464
-1.0	88139	37.0	28355	75.0	10501	113.0	4367
0.0	85371	38.0	27577	76.0	10247	114.0	4274
1.0	82699	39.0	26823	77.0	10000	115.0	4182
2.0	80121	40.0	26092	78.0	9760	116.0	4093
3.0	77632	41.0	25383	79.0	9526	117.0	4006
4.0	75230	42.0	24696	80.0	9299	118.0	3921
5.0	72910	43.0	24030	81.0	9077	119.0	3838
6.0	70670	44.0	23384	82.0	8862	120.0	3757
7.0	68507	45.0	22758	83.0	8653	121.0	3678
8.0	66418	46.0	22150	84.0	8449	122.0	3601
9.0	64399	47.0	21561	85.0	8250	123.0	3526
10.0	62449	48.0	20989	86.0	8057	124.0	3452
11.0	60565	49.0	20435	87.0	7869		
12.0	58745	50.0	19896	88.0	7686		

SERVICE HINTS

1. Caution homeowner to maintain clean air filters at all times. Also, not to needlessly close off supply and return air registers. This reduces air flow through the system which shortens equipment service life as well as increasing operating costs.
2. Switching to heating cycle at 75°F or higher outside temperature may cause a nuisance trip of the manual reset high pressure switch.
3. The heat pump wall thermostats perform multiple functions. Be sure that all function switches are correctly set for the desired operating mode before trying to diagnose any reported service problems.
4. Check all power fuses or circuit breakers to be sure that they are the correct rating.
5. Periodic cleaning of the outdoor coil to permit full and unrestricted airflow circulation is essential.

PRESSURE SERVICE PORTS

High and low pressure service ports are installed on all units so that the system operating pressures can be observed. Pressure tables can be found in Tables 16 through 23 in this manual covering all models on both cooling and heating cycles. It is imperative to match the correct pressure table to the unit by model number.

REFRIGERANT CHARGE

The correct system R-22 charge is shown on the unit rating plate. Optimum unit performance will occur with a refrigerant charge resulting in a suction line temperature (6" from compressor) as shown in Table 13.

TABLE 13

Model	Rated Airflow	95° OD Temperature	82° OD Temperature
PH11242	800	56 - 57	65 - 67
PH12241	800	64 - 66	67 - 69
PH1130	1000	56 - 58	58 - 60
PH1230	1000	56 - 58	58 - 60
PH1136	1100	50 - 52	52 - 54
PH1236	1100	50 - 52	52 - 54
PH1142	1400	54 - 56	57 - 59
PH1242	1400	54 - 56	57 - 59
PH1048	1550	55 - 57	58 - 60
PH1248	1550	55 - 57	57 - 59
PH1060	1700	52 - 54	57 - 59

The above suction line temperatures are based upon 80°F dry bulb/67°F wet bulb (50% RH) temperature and rated airflow across the evaporator during cooling cycle.

FAN BLADE SETTINGS

Shown in Figure 13 are the correct fan blade setting dimensions for proper air delivery across the outdoor coil.

Any service work requiring removal or adjustment in the fan and/or motor area will require that the dimensions in Table 14 be checked and blade adjusted in or out on the motor shaft accordingly.

**FIGURE 13
FAN BLADE SETTING**

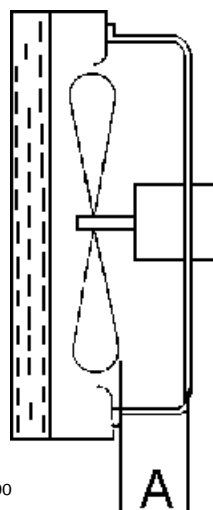

**TABLE 14
FAN BLADE SETTING
DIMENSIONS**

Model	Dimension "A"
PH1124 PH1224	1.00"
PH1130 PH1230 PH1136 PH1236	.75"
PH11422 PH1242 PH1048 PH1248 PH1060	1.75"

SUCTION AND DISCHARGE TUBE BRAZING

Compliant Scroll compressors have copper plated steel suction and discharge tubes. These tubes are far more rugged and less prone to leaks than copper tubes used on other compressors. Due to different thermal properties of steel and copper, brazing procedures may have to be changed from those commonly used.

- To disconnect: heat joint Areas 2 and 3 slowly and uniformly until braze material softens and the tube can be pulled out of suction fitting. (See Figure 14.)
- To connect:
 - Recommended brazing materials: silfos with minimum 5% silver or silver braze material with flux.

- Reinsert tube into fitting.
- Heat tube uniformly in Area 1 moving slowly to Area 2. When joint reaches brazing temperature, apply brazing material. (See Figure 14.)
- Heat joint uniformly around the circumference to flow braze material completely around the joint.
- Slowly move torch into Area 3 to draw braze material into joint. (See Figure 14.)
- **Do not** overheat joint.

**FIGURE 14
BRAZING DIAGRAM**

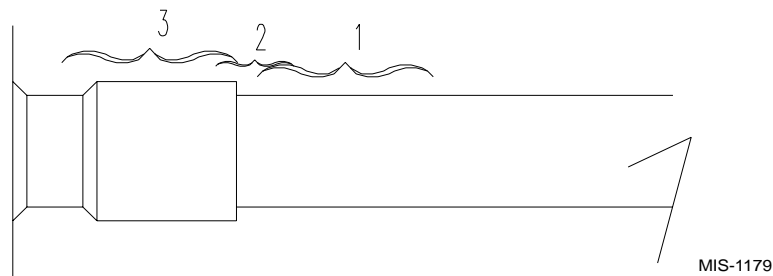

**TABLE 15
INDOOR BLOWER PERFORMANCE**

/ /ESP in H ₂ O	PH1124 Dry/Wet Coil	PH1130 Dry/Wet Coil	PH1136 Dry/Wet Coil	PH1142 Dry/Wet Coil	PH1048 Dry/Wet Coil	PH1060 Dry/Wet Coil
0.0	915 / 900	1320 / 1250	1320 / 1250	1650 / 1625	1950 / 1920	1850 / 1850
0.1	860 / 835	1280 / 1175	1280 / 1175	1500 / 1525	1860 / 1830	1800 / 1780
0.2	815 / 800	1230 / 1100	1230 / 1100	1435 / 1400	1780 / 1750	1725 / 1700
0.3	785 / 750	1180 / 1000	1180 / 1000	1340 / 1310	1680 / 1660	1660 / 1625
0.4	750 / 710	1130 / 950	1130 / 950	1230 / 1210	1580 / 1550	1580 / 1540
0.5	740 / 700	1070 / 890	1070 / 890	1120 / 1000	1500 / 1480	NA

TROUBLESHOOTING ECM BLOWER MOTORS



CAUTION

Disconnect power from unit before removing or replacing connectors, or servicing motor. Wait at least 5 minutes after disconnection power before opening motor.

SYMPTOM

Motor rocks slightly when starting.

Motor won't start

- No movement

- Motor rocks, but won't start

Motor oscillates up and down while being tested off of blower

- Noisy blower of cabinet

- "Hunts" or "puffs" at high CFM (speed)

Evidence of Moisture

- Motor failure or malfunction has occurred and moisture is present
- Evidence of moisture present inside air mover

DO

- Check out motor, controls, wiring and connections thoroughly before replacing motor
- Orient connectors down so water can't get in; install "drip loops"
- Use authorized motor and control model numbers for replacement
- Keep static pressure to a minimum:
 - Recommend high efficiency, low static filters
 - Recommend keeping filters clean
 - Design duct work for minimum static, maximum comfort
 - Look for and recommend duct work improvement, where necessary, in replacement.

CAUSE / PROCEDURE

- This is normal start-up for ICM

- Check power at motor
- Check low voltage (24 VAC R to C) at motor
- Check low voltage connections (G, Y, W, R, C) at motor
- Check for unseated pins in connectors on motor harness
- Test with a temporary jumper between R - G
- Check motor for tight shaft
- Run **Moisture Check**

- Check for loose or compliant motor mount
- Make sure blower wheel is tight on shaft

- It is normal for motor to oscillate with no load on shaft.

- Check for loose blower housing, panels, etc.
- High static creating high blower speed?
 - Check for air whistling through seams in ducts, cabinets or panels.
 - Check for cabinet / duct deformation

- Does removing panel or filter reduce "puffing"?
 - Reduce restriction
 - Reduce maximum airflow

- Replace motor and perform **Moisture Check**

- Perform Moisture Check

DON'T

- Automatically assume the motor is bad
- Locate connectors above 7 and 4 o'clock positions
- Replace one motor of control model number with another (unless an authorized replacement)
- Use high pressure drop filters. Some have 1/2" H₂O drop!
- Use restricted returns

SYMPTOM

Motor starts but runs erratically

- Varies up and down or intermittent
- "Hunts" or puffs" at high CRM (speed)
- Stays at low CFM despite system call for cool or heat CFM
- Stays at high CFM
- Blower won't shut off

SYMPTOM

Excessive noise

- Air Noise

DO

- Size the equipment wisely
- Check orientation before inserting motor connectors

MOISTURE CHECK PROCEDURE

- Connectors are oriented "down"
- Arrange harnesses with "drip loop" under motor
- Condensate drain plugged?
- Check for low airflow (too much latent capacity)
- Check for undercharged condition
- Check and plug leaks in return ducts and cabinet

CAUSE / PROCEDURE

- Check line voltage for variation or "sag"
- Check low voltage connections (G, Y, W, R, C) at motor; unseated pins in motor harness connectors
- Check "Bk" for erratic CFM command (in variable speed applications)
- Check out system controls - thermostat?
- Perform **Moisture Check**
- Does removing panel or filter reduce "puffing"?
 - Reduce restriction
 - Reduce maximum airflow
- Check low voltage (thermostat) wires and connections
- Verify fan is not in delay mode - wait until delay is complete
- "R" missing / not connected at motor
Perform motor / control replacement check
- "R" missing / not connected at motor
- Is fan in delay mode? - wait until delay time complete
- Current leakage from controls into G, Y or W?
 - Check for Triac switched thermostat or solid state relay

CAUSE / PROCEDURE

- Determine if it is air noise, cabinet, duct or motor noise . Interview customer if necessary.
- High static creating high blower speed?
 - Is airflow set properly?
 - Does removing filter cause blower to slow down?
Check / replace filter
 - Use low pressure drop filter
 - Check / correct duct restrictions

DONT

- Oversize system then compensate with low airflow
- Plug in power connector backwards
- Force plugs

COMFORT CHECK PROCEDURE

- Check proper airflow settings
- Low static pressure for lowest noise
- Set low continuous fan CFM
- Use humidistat and 2-speed cooling units
- Use zoning controls designed for ICM that regulate CFM
- Thermostat in bad location?

PRESSURE TABLES

TABLE 16

COOLING

Air Temperature Entering Outdoor Coil Degrees F

Model	Return Air Temperature	Pressure	75	80	85	90	95	100	105	110	115
PH1124	75 deg. DB 62 deg. WB	Low Side High Side	73 191	75 209	76 227	77 245	78 263	79 281	80 299	81 317	83 355
	80 deg. DB 67 deg. WB	Low Side High Side	79 196	81 215	82 233	83 252	84 270	85 288	86 307	87 325	89 344
	85 deg. DB 72 deg. WB	Low Side High Side	85 203	87 222	88 242	89 261	90 280	91 299	92 318	93 338	95 357
PH1130	75 deg. DB 62 deg. WB	Low Side High Side	73 208	74 226	76 245	77 264	79 283	81 302	82 321	84 340	85 358
	80 deg. DB 67 deg. WB	Low Side High Side	77 231	79 232	81 252	83 271	85 290	87 309	89 328	91 348	93 367
	85 deg. DB 72 deg. WB	Low Side High Side	83 220	85 240	87 260	89 280	91 300	93 320	95 340	97 360	99 380
PH1136	75 deg. DB 62 deg. WB	Low Side High Side	70 209	72 227	73 245	74 262	75 280	76 298	77 315	78 333	80 351
	80 deg. DB 67 deg. WB	Low Side High Side	75 215	77 233	78 251	79 270	80 287	81 305	82 323	83 341	85 359
	85 deg. DB 72 deg. WB	Low Side High Side	80 222	81 240	83 259	84 278	86 297	88 316	89 335	91 354	92 372

TABLE 17

HEATING

Air Temperature Entering Outdoor Coil Degrees F

Model	Return Air Temp.	Pressure	0	5	10	15	17	20	25	30	35	40	45	47	50	55	60
PH1124	70 deg	Low Side	12	16	21	26	28	31	36	41	45	50	55	57	60	65	70
		High Side	293	193	200	207	210	214	221	229	236	243	250	253	257	264	272
PH1130	70 deg	Low Side	31	28	27	27	27	28	30	34	39	45	53	56	61	71	83
		High Side	179	177	176	177	178	180	184	189	196	205	215	219	226	239	254
PH1136	70 deg	Low Side	41	33	28	25	24	24	24	27	32	39	48	52	59	72	87
		High Side	215	199	188	180	178	176	176	179	186	197	211	218	229	251	277

Low side pressure ± 2 PSIG

High side pressure ± 5 PSIG

Tables are based upon rated CFM (airflow across the evaporator coil and should be found under section titled "Refrigerant Charge" elsewhere in manual. If there is any doubt as to correct operating charge being in the system, the charge should be removed, system evacuated, and recharged to serial plate instructions.

PRESSURE TABLES

TABLE 18

COOLING

Air Temperature Entering Outdoor Coil Degrees F

Model	Return Air Temperature	Pressure	75	80	85	90	95	100	105	110	115
PH1142	75 deg. DB 62 deg. WB	Low Side High Side	74 192	75 210	77 227	78 244	79 261	80 279	81 296	82 314	83 332
	80 deg. DB 67 deg. WB	Low Side High Side	79 197	80 215	82 233	83 250	84 268	85 286	87 304	88 322	89 340
	85 deg. DB 72 deg. WB	Low Side High Side	85 204	86 223	88 241	89 259	90 277	91 296	94 315	95 333	96 352
PH1048	75 deg. DB 62 deg. WB	Low Side High Side	71 211	73 226	75 243	76 258	77 276	78 293	79 310	80 329	81 347
	80 deg. DB 67 deg. WB	Low Side High Side	76 216	78 232	80 249	81 265	83 283	84 300	85 318	86 337	87 356
	85 deg. DB 72 deg. WB	Low Side High Side	81 224	83 240	86 258	87 274	89 292	90 311	91 329	92 349	94 368
PH1060	75 deg. DB 62 deg. WB	Low Side High Side	65 199	66 216	68 235	69 254	70 272	71 291	72 309	73 328	74 345
	80 deg. DB 67 deg. WB	Low Side High Side	70 204	71 222	72 241	73 260	75 279	76 298	77 317	78 336	79 354
	85 deg. DB 72 deg. WB	Low Side High Side	75 211	76 230	77 249	78 269	80 289	82 308	83 328	84 348	85 366

TABLE 19

HEATING

Air Temperature Entering Outdoor Coil Degrees F

Model	Return Air Temp.	Pressure	0	5	10	15	17	20	25	30	35	40	45	47	50	55	60
PH1142	70 deg	Low Side	17	19	21	26	29	33	38	45	49	52	55	56	58	61	64
		High Side	156	161	165	169	171	173	177	181	186	193	199	203	207	214	221
PH1048	70 deg	Low Side	25	27	29	31	32	34	36	38	40	47	54	56	60	67	73
		High Side	160	164	168	172	174	176	180	184	188	194	201	204	208	214	221
PH1060	70 deg	Low Side	17	19	21	24	26	29	33	37	41	46	50	52	55	59	64
		High Side	156	164	172	180	183	187	195	203	211	219	226	230	234	243	250

Low side pressure \pm 2 PSIG

High side pressure \pm 5 PSIG

Tables are based upon rated CFM (airflow across the evaporator coil and should be found under section titled "Refrigerant Charge" elsewhere in manual. If there is any doubt as to correct operating charge being in the system, the charge should be removed, system evacuated, and recharged to serial plate instructions.

PRESSURE TABLES

TABLE 20

COOLING

Air Temperature Entering Outdoor Coil Degrees F

Model	Return Air Temperature	Pressure	75	80	85	90	95	100	105	110	115
PH1224	75 deg. DB 62 deg. WB	Low Side High Side	73 191	75 205	76 219	78 234	79 251	80 267	81 285	82 303	83 323
	80 deg. DB 67 deg. WB	Low Side High Side	78 196	80 210	81 225	83 240	84 257	88 274	87 292	88 311	89 331
	85 deg. DB 72 deg. WB	Low Side High Side	81 203	83 217	84 233	86 248	87 266	89 284	90 302	91 322	92 343
PH1230	75 deg. DB 62 deg. WB	Low Side High Side	73 208	75 222	76 237	78 254	79 270	79 288	81 307	82 326	84 346
	80 deg. DB 67 deg. WB	Low Side High Side	78 213	80 228	81 243	83 260	84 277	85 295	87 315	88 334	90 355
	85 deg. DB 72 deg. WB	Low Side High Side	81 220	83 236	84 252	86 269	87 287	88 305	90 326	91 346	93 367
PH1236	75 deg. DB 62 deg. WB	Low Side High Side	72 211	74 225	75 242	77 258	78 276	79 294	80 314	81 333	82 355
	80 deg. DB 67 deg. WB	Low Side High Side	77 216	79 231	80 248	82 265	83 283	84 302	86 322	87 342	88 364
	85 deg. DB 72 deg. WB	Low Side High Side	80 224	82 239	83 257	85 274	86 293	87 313	89 333	90 354	91 377

TABLE 21

HEATING

Air Temperature Entering Outdoor Coil Degrees F

Model	Return Air Temp.	Pressure	0	5	10	15	17	20	25	30	35	40	45	47	50	55
PH1224	70 deg	Low Side	22	24	27	30	31	33	37	41	45	50	56	58	62	68
		High Side	174	182	190	198	201	205	213	221	229	237	245	248	253	261
PH1230	70 deg	Low Side	21	23	25	28	29	31	34	38	43	48	53	55	59	65
		High Side	167	170	174	178	179	182	187	192	197	203	210	213	217	224
PH1236	70 deg	Low Side	24	25	26	28	28	30	33	37	42	47	53	56	60	68
		High Side	194	195	197	201	202	205	211	218	226	235	246	250	257	270

Low side pressure ± 2 PSIG

High side pressure ± 5 PSIG

Tables are based upon rated CFM (airflow across the evaporator coil and should be found under section titled "Refrigerant Charge" elsewhere in manual. If there is any doubt as to correct operating charge being in the system, the charge should be removed, system evacuated, and recharged to serial plate instructions.

PRESSURE TABLES

TABLE 22

COOLING

Air Temperature Entering Outdoor Coil Degrees F

Model	Return Air Temperature	Pressure	75	80	85	90	95	100	105	110	115
PH1242	75 deg. DB 62 deg. WB	Low Side	74	76	77	78	79	79	81	81	82
		High Side	196	211	225	241	257	274	291	308	326
	80 deg. DB 67 deg. WB	Low Side	79	81	82	83	84	85	87	87	88
		High Side	201	216	231	247	264	281	298	316	334
	85 deg. DB 72 deg. WB	Low Side	82	84	85	86	87	88	90	90	91
		High Side	208	224	239	256	273	291	308	327	346
PH1248	75 deg. DB 62 deg. WB	Low Side	72	74	76	77	79	80	81	83	84
		High Side	203	251	230	245	261	280	298	319	340
	80 deg. DB 67 deg. WB	Low Side	77	79	81	82	84	86	87	89	90
		High Side	208	221	236	251	268	287	306	327	349
	85 deg. DB 72 deg. WB	Low Side	80	82	84	85	87	89	90	92	93
		High Side	215	229	244	260	277	297	317	338	361

TABLE 23

HEATING

Air Temperature Entering Outdoor Coil Degrees F

Model	Return Air Temp.	Pressure	0	5	10	15	17	20	25	30	35	40	45	47	50	55	60
PH1242	70 deg	Low Side	26	26	28	30	31	32	36	40	44	49	55	58	62	69	77
		High Side	160	164	168	173	174	177	182	187	192	198	204	206	210	216	223
PH1248	70 deg	Low Side	26	26	27	28	29	30	33	37	41	46	52	54	58	65	73
		High Side	165	166	168	170	171	173	177	182	187	194	201	204	209	217	227

Low side pressure \pm 2 PSIG

High side pressure \pm 5 PSIG

Tables are based upon rated CFM (airflow across the evaporator coil and should be found under section titled "Refrigerant Charge" elsewhere in manual. If there is any doubt as to correct operating charge being in the system, the charge should be removed, system evacuated, and recharged to serial plate instructions.

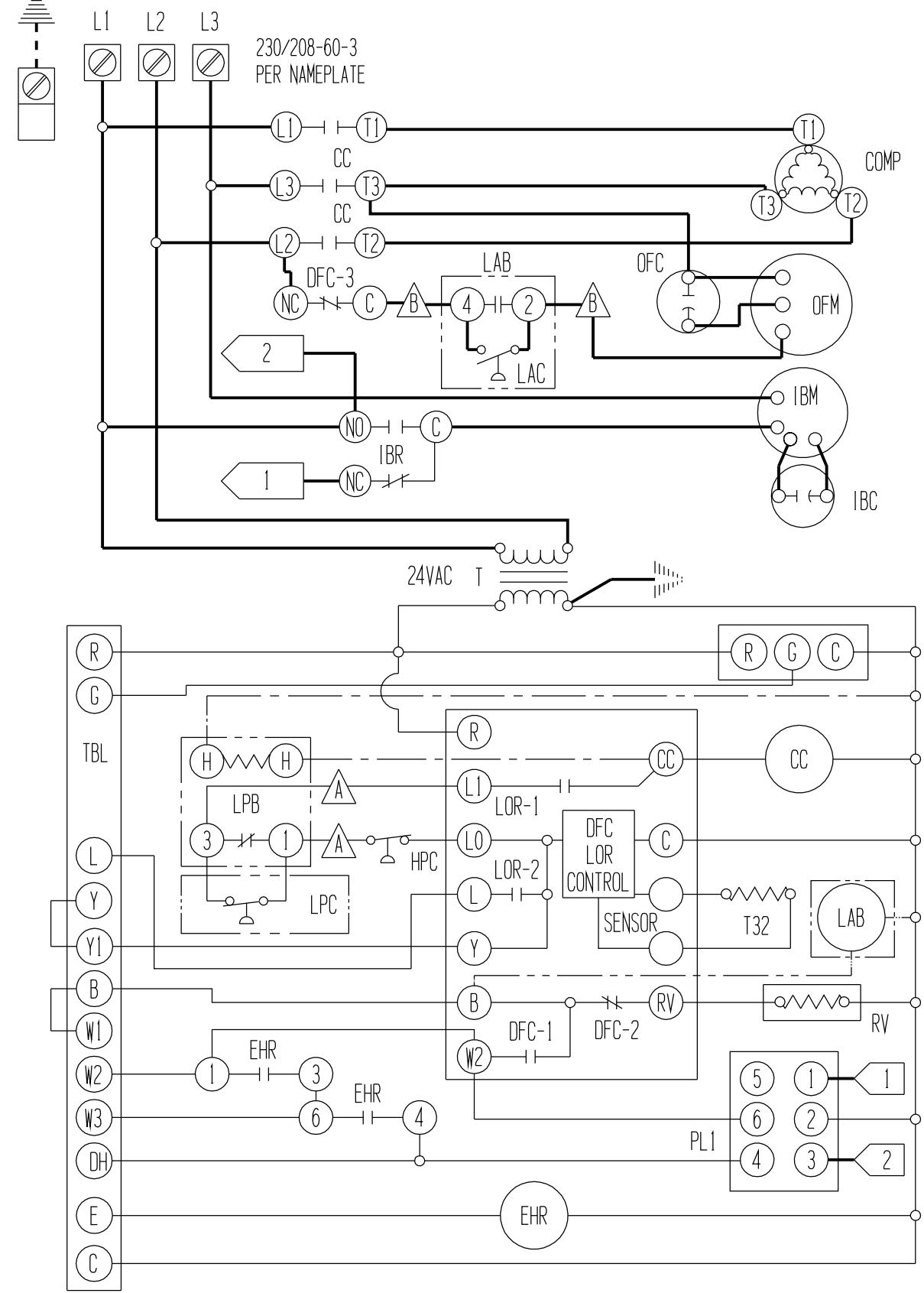
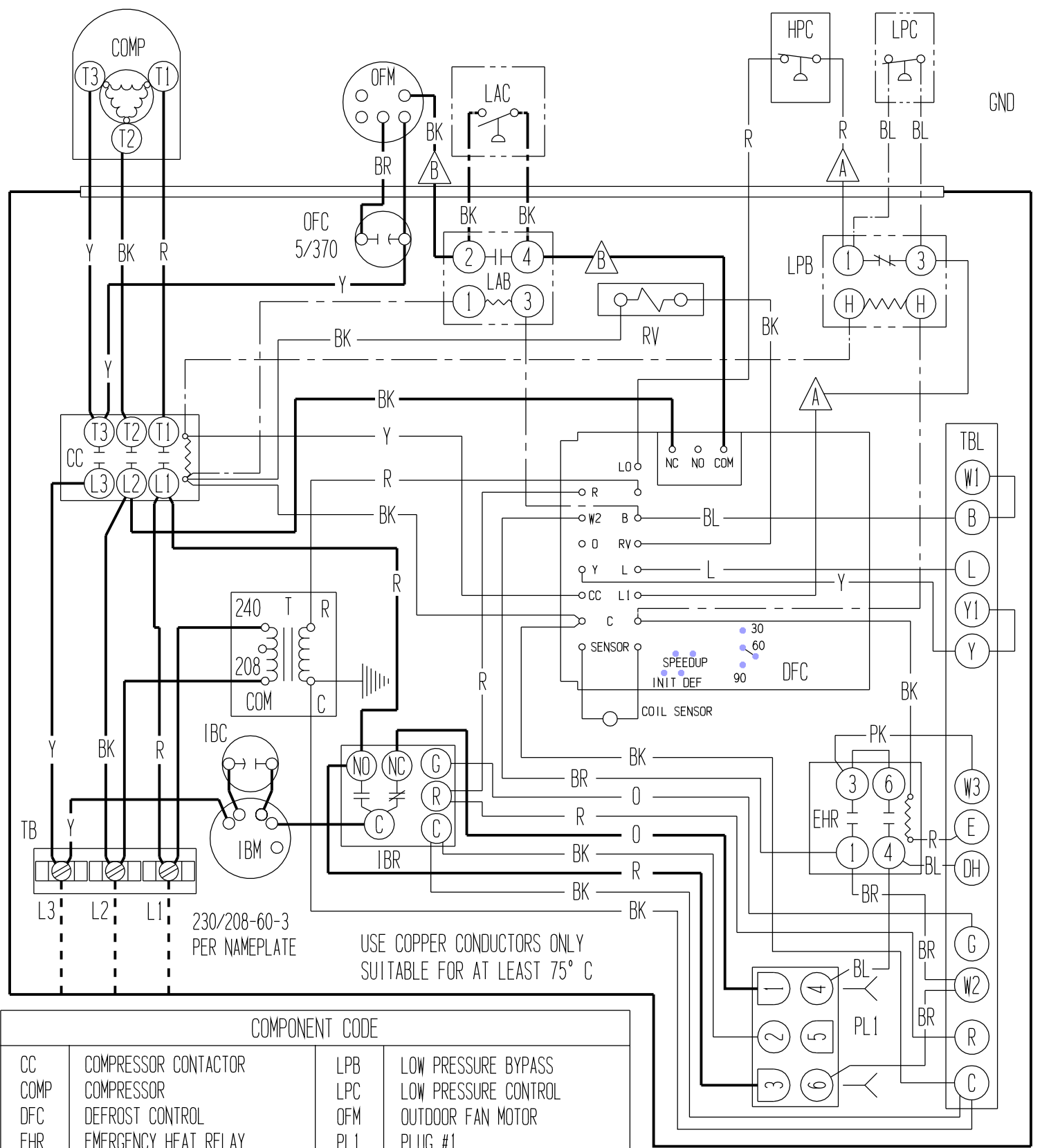

COMPONENT CODE			
CC	COMPRESSOR CONTACTOR	LPB	LOW PRESSURE BYPASS
COMP	COMPRESSOR	LPC	LOW PRESSURE CONTROL
DFC	DEFROST CONTROL	OFM	OUTDOOR FAN MOTOR
EHR	EMERGENCY HEAT RELAY	PL1	PLUG #1
GND	EQUIPMENT GROUND	RV	REV. VALVE SOLINOID
HPC	HIGH PRESSURE CONTROL	TCT	TOP CAP THERMOSTAT
IBC	INDOOR BLOWER CAPACITOR	T	TRANSFORMER
IBM	INDOOR BLOWER MOTOR	TB	TERMINAL BLOCK
IBR	INDOOR BLOWER RELAY	TBL	LOW VOLTAGE TERMINAL BLOCK
LAB	LOW AMBIENT BYPASS CONTROL	OFC	OUTDOOR FAN CAPACITOR
LAC	LOW AMBIENT CONTROL		

		FACTORY STD.	FIELD	OPTIONAL	COLOR CODE				BARD MFG. CO. 4065-211 A			
HIGH VOLTAGE		————	-----	-----	BK	BLACK	Y	YELLOW		V	VIOLET	T
LOW VOLTAGE		————	-----	-----	BR	BROWN	G	GREEN	(PR)	PURPLE	PK	PINK
ACCESSORY		————	-----	-----	R	RED	BL	BLUE	GY	GRAY	L	LAVENDER
		————	-----	-----	O	ORANGE	W	WHITE	(S)	SLATE		

⚠️, ⚠️ LABELED WIRES CONNECT IF NO OPTIONS USED. ⚠️ MOVE RED WIRE TO 208V TAP FOR 208V OPERATION

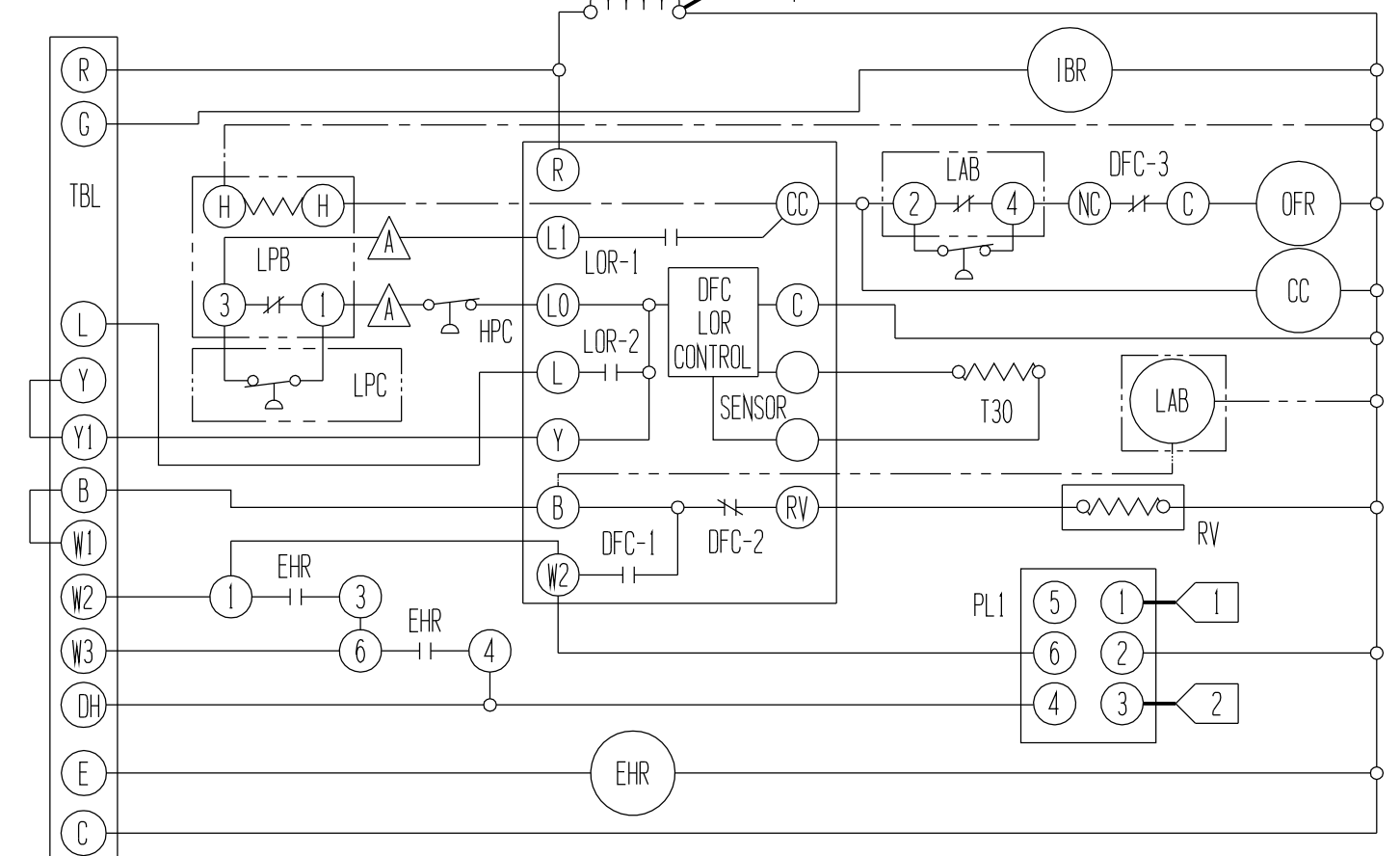
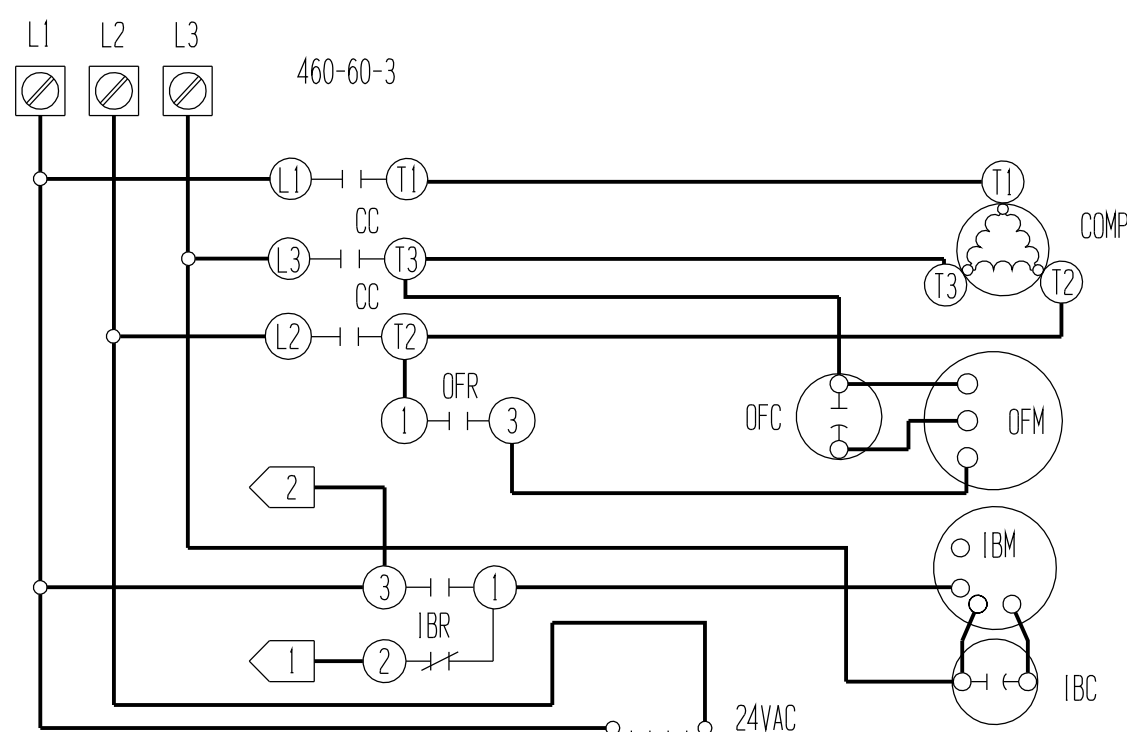
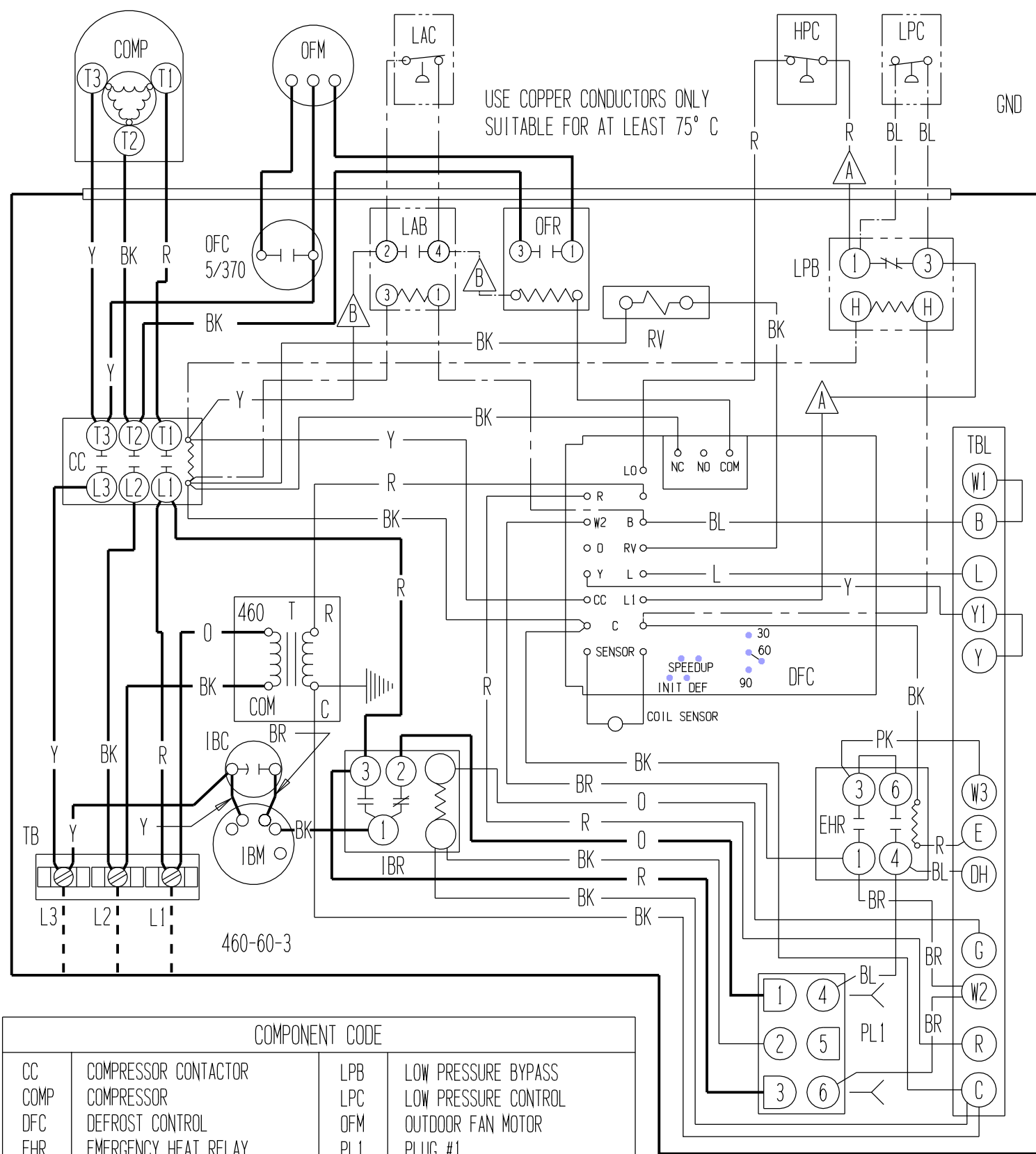

COMPONENT CODE			
CC	COMPRESSOR CONTACTOR	LPB	LOW PRESSURE BYPASS
COMP	COMPRESSOR	LPC	LOW PRESSURE CONTROL
DFC	DEFROST CONTROL	OFM	OUTDOOR FAN MOTOR
EHR	EMERGENCY HEAT RELAY	PL1	PLUG #1
GND	EQUIPMENT GROUND	RV	REV. VALVE SOLINOID
HPC	HIGH PRESSURE CONTROL	T	TRANSFORMER
IBC	INDOOR BLOWER CAPACITOR	TB	TERMINAL BLOCK
IBM	INDOOR BLOWER MOTOR	TBL	LOW VOLTAGE TERMINAL BLOCK
IBR	INDOOR BLOWER RELAY	OFC	OUTDOOR FAN CAPACITOR
LAB	LOW AMBIENT BYPASS CONTROL	OFR	OUTDOOR FAN RELAY
LAC	LOW AMBIENT CONTROL		

A, **B** LABELED WIRES CONNECT IF NO OPTIONS USED.

	FACTORY STD.	FIELD	OPTIONAL
HIGH VOLTAGE	————	-----	-----
LOW VOLTAGE	————	-----	-----
ACCESSORY	————	-----	-----

COLOR CODE							
BK	BLACK	Y	YELLOW	V	VIOLET	T	TAN
BR	BROWN	G	GREEN	(PR)	PURPLE	PK	PINK
R	RED	BL	BLUE	GY	GRAY	L	LAVENDER
O	ORANGE	W	WHITE	(S)	SLATE		

BARD MFG. CO.
4065-311 B

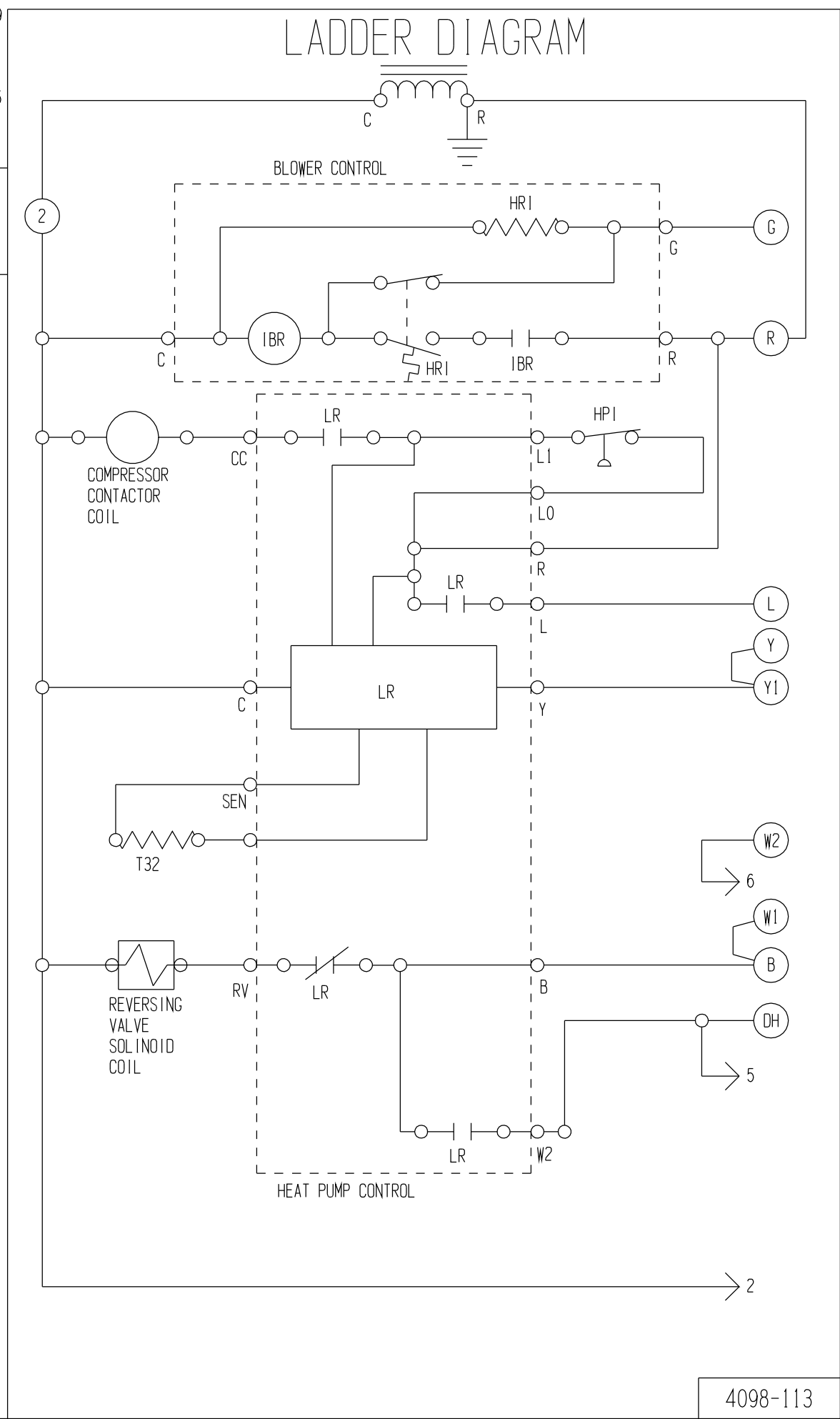
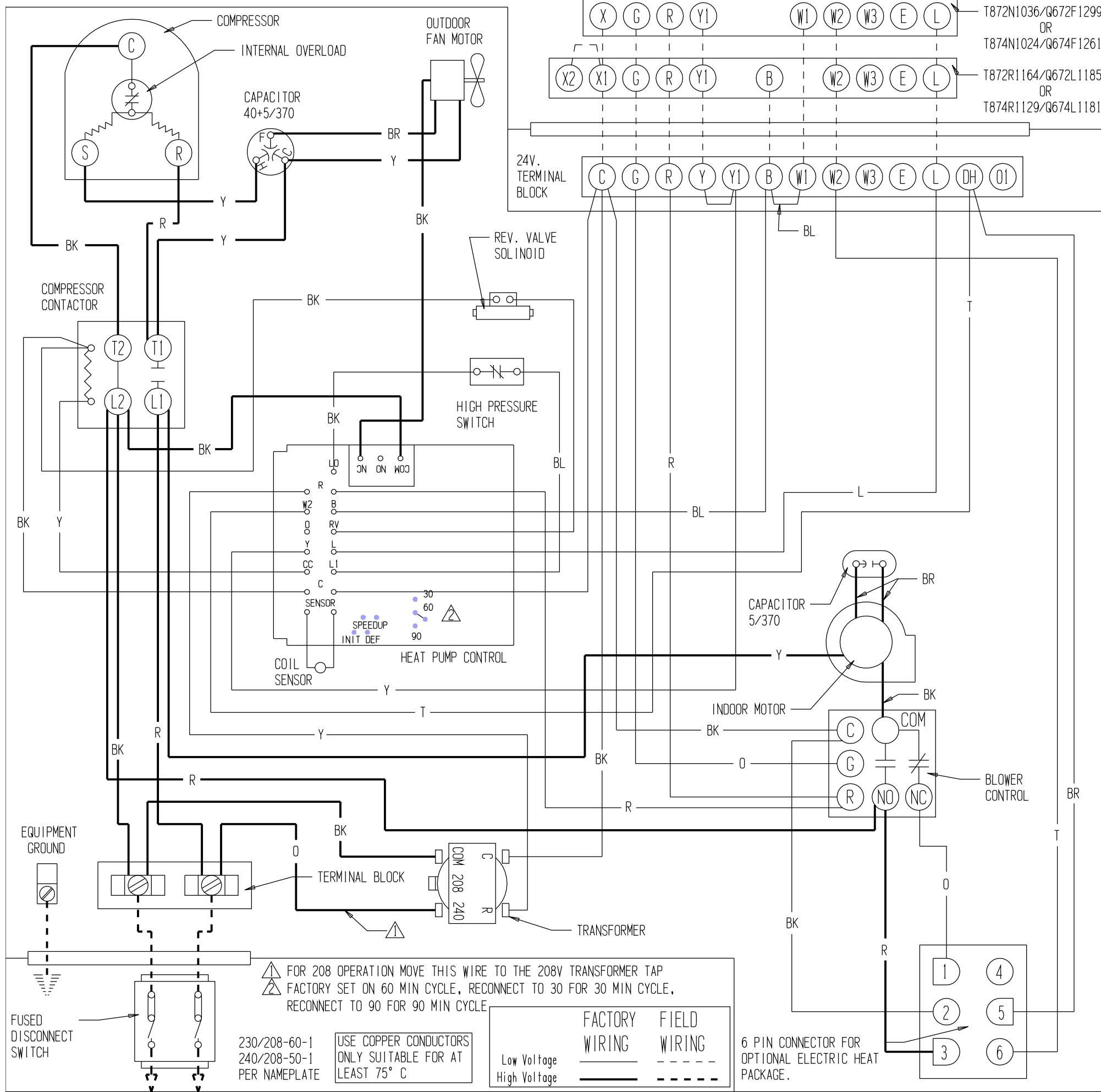

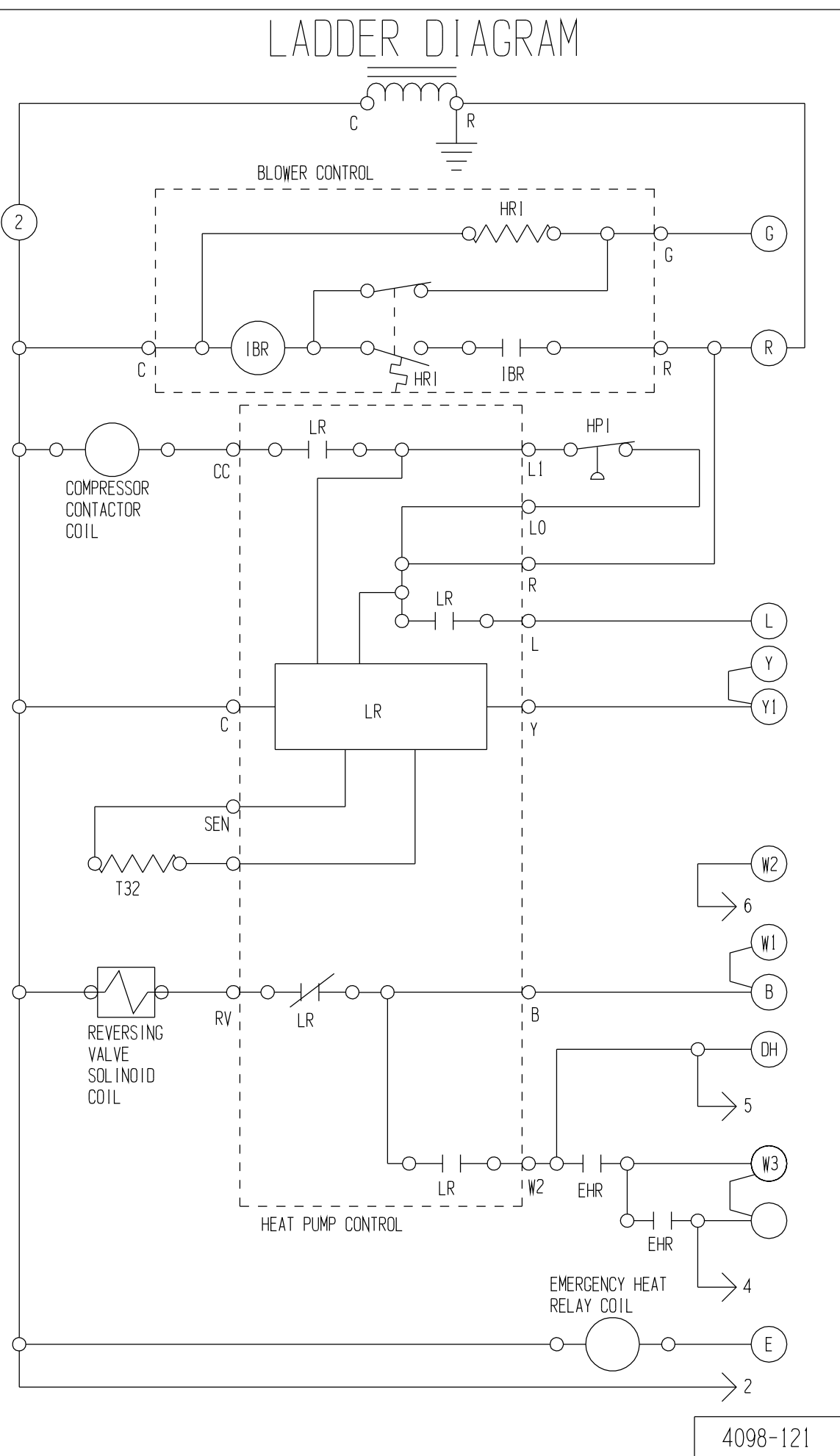
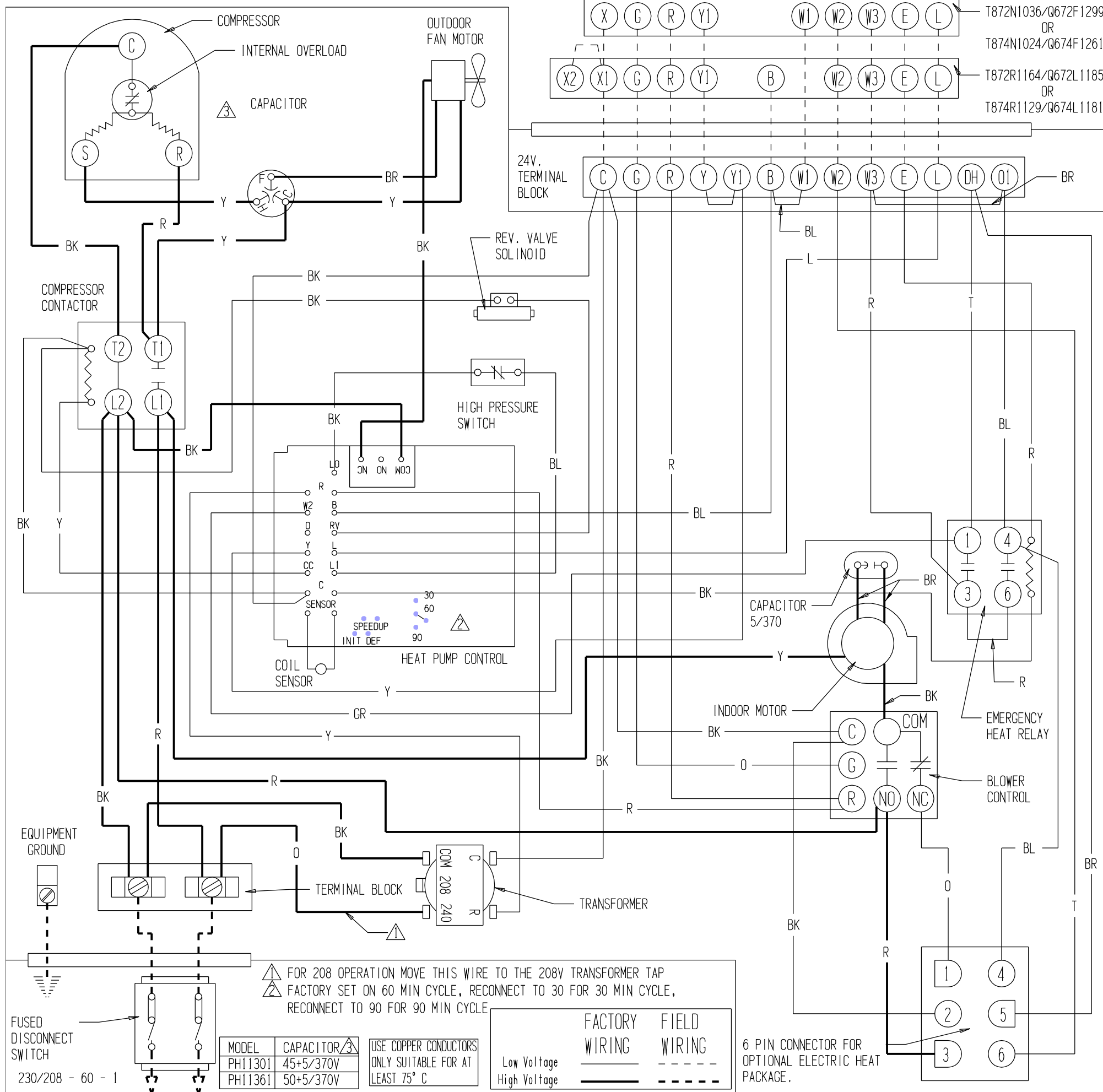

⚠ FOR 208 OPERATION MOVE THIS WIRE TO THE 208V TRANSFORMER TAP
 ⚠ FACTORY SET ON 60 MIN CYCLE, RECONNECT TO 30 FOR 30 MIN CYCLE,
 RECONNECT TO 90 FOR 90 MIN CYCLE

MODEL	CAPACITOR	USE COPPER CONDUCTORS ONLY SUITABLE FOR AT LEAST 75° C
PHI1301	45+5/370V	
PHI1361	50+5/370V	

	FACTORY WIRING	FIELD WIRING
Low Voltage	————	-----
High Voltage	————	-----

6 PIN CONNECTOR FOR
OPTIONAL ELECTRIC HEAT
PACKAGE.

FUSED
DISCONNECT
SWITCH
230/208 - 60 - 1

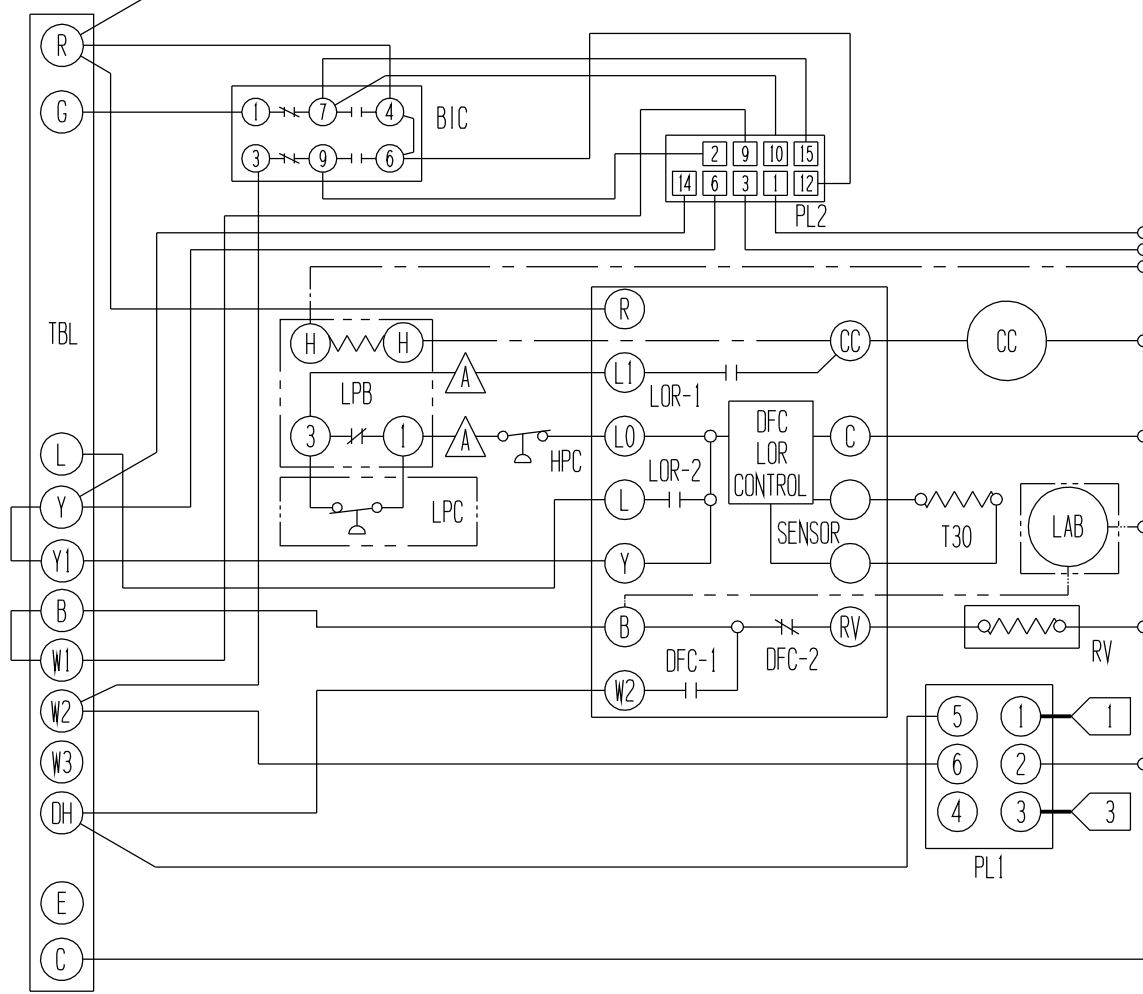
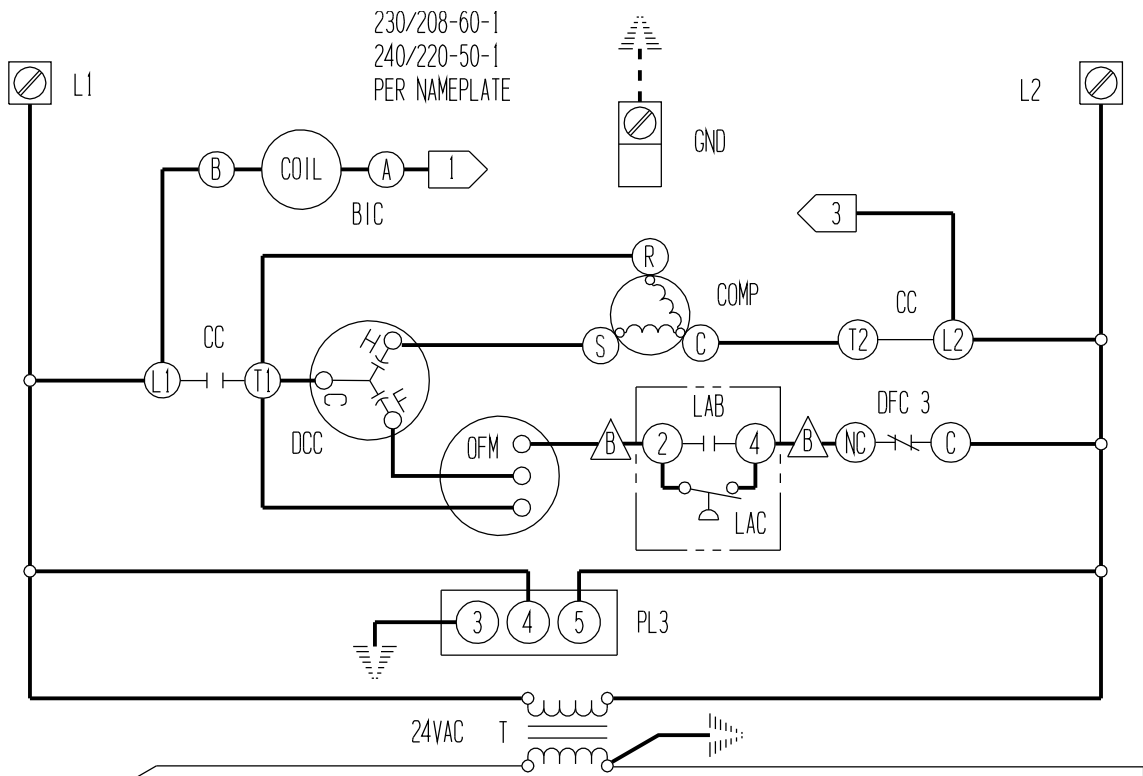
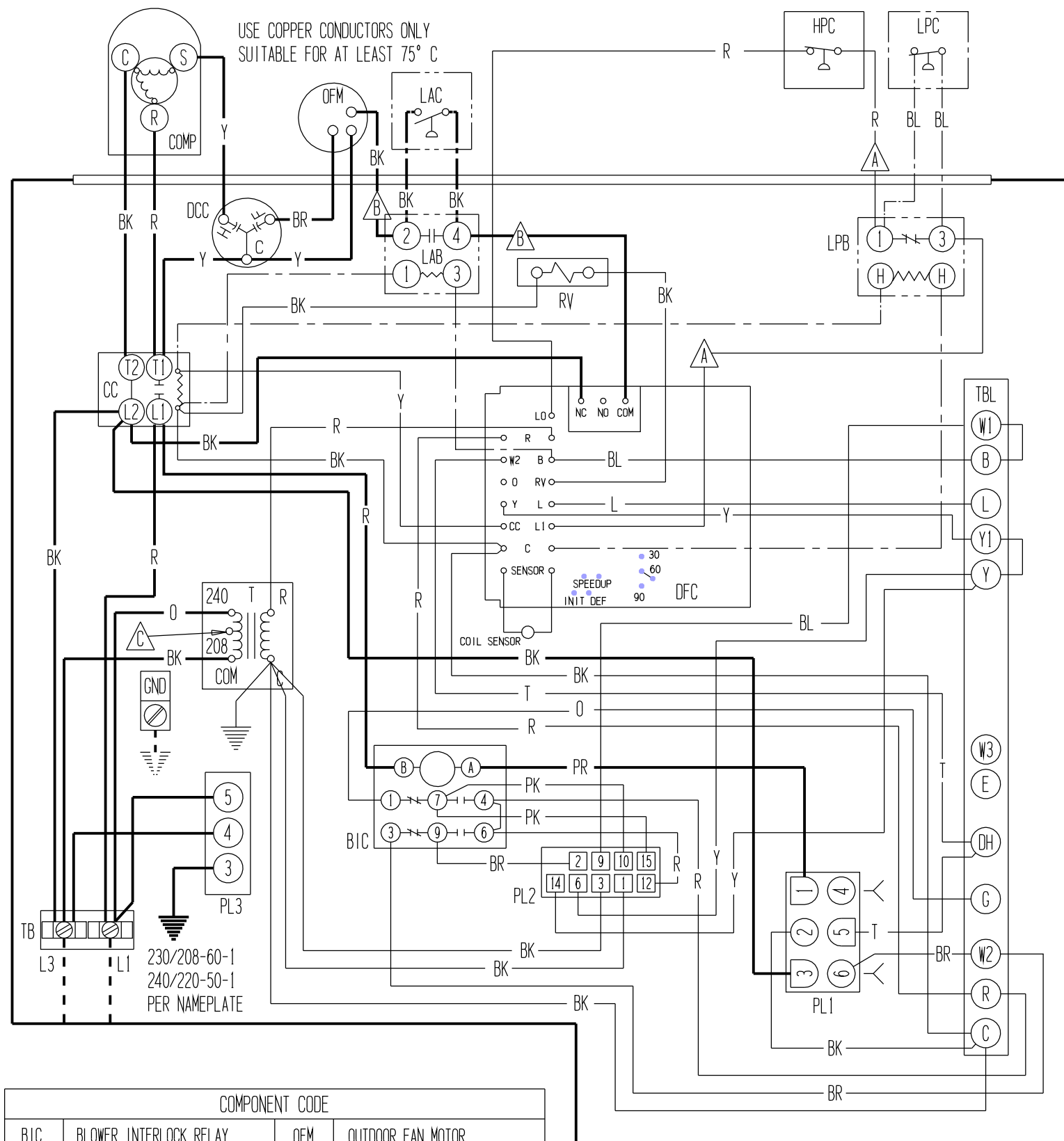

COMPONENT CODE			
BIC	BLOWER INTERLOCK RELAY	OFM	OUTDOOR FAN MOTOR
CC	COMPRESSOR CONTACTOR	PL1	PLUG #1
COMP	COMPRESSOR	PL2	PLUG #2
DCC	DUAL CAN CAPACITOR	PL3	PLUG #3
DFC	DEFROST CONTROL	RV	REV. VALVE SOLINOID
GND	EQUIPMENT GROUND	T	TRANSFORMER
HPC	HIGH PRESSURE CONTROL	TB	TERMINAL BLOCK
LAB	LOW AMBIENT BYPASS CONTROL	TBL	LOW VOLTAGE TERMINAL BLOCK
LAC	LOW AMBIENT CONTROL		
LPB	LOW PRESSURE BYPASS		
LPC	LOW PRESSURE CONTROL		

CAPACITOR	PART NO.	MODEL
45/5 370	8552-052	PH1224

A, A LABELED WIRES CONNECT IF NO OPTIONS USED. A MOVE RED WIRE TO 208V TAP FOR 208V OPERATION

HIGH VOLTAGE	FACTORY STD.	FIELD	OPTIONAL	COLOR CODE			
	————	- - - -	-----	BK	Y	V	T
LOW VOLTAGE	————	- - - -	-----	BR	G	(PR)	PK
ACCESSORY	————	- - - -	-----	R	BL	GY	L
				O	W	(S)	

BARD MFG. CO.
4098-123 A

230/208-60-1
240/220-50-1
PER NAMEPLATE

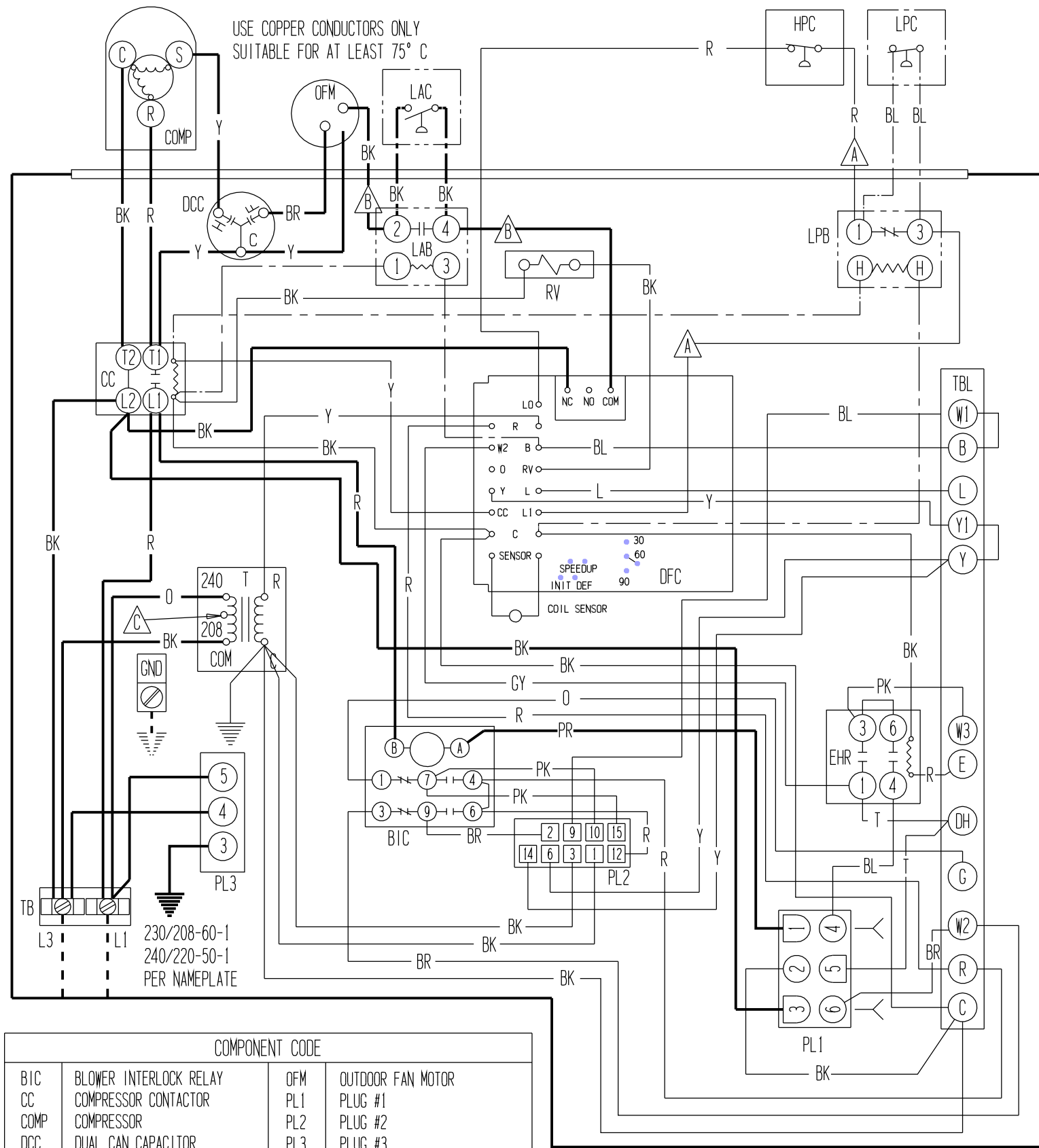

USE COPPER CONDUCTORS ONLY
SUITABLE FOR AT LEAST 75° C

230/208-60-1
240/220-50-1
PER NAMEPLATE

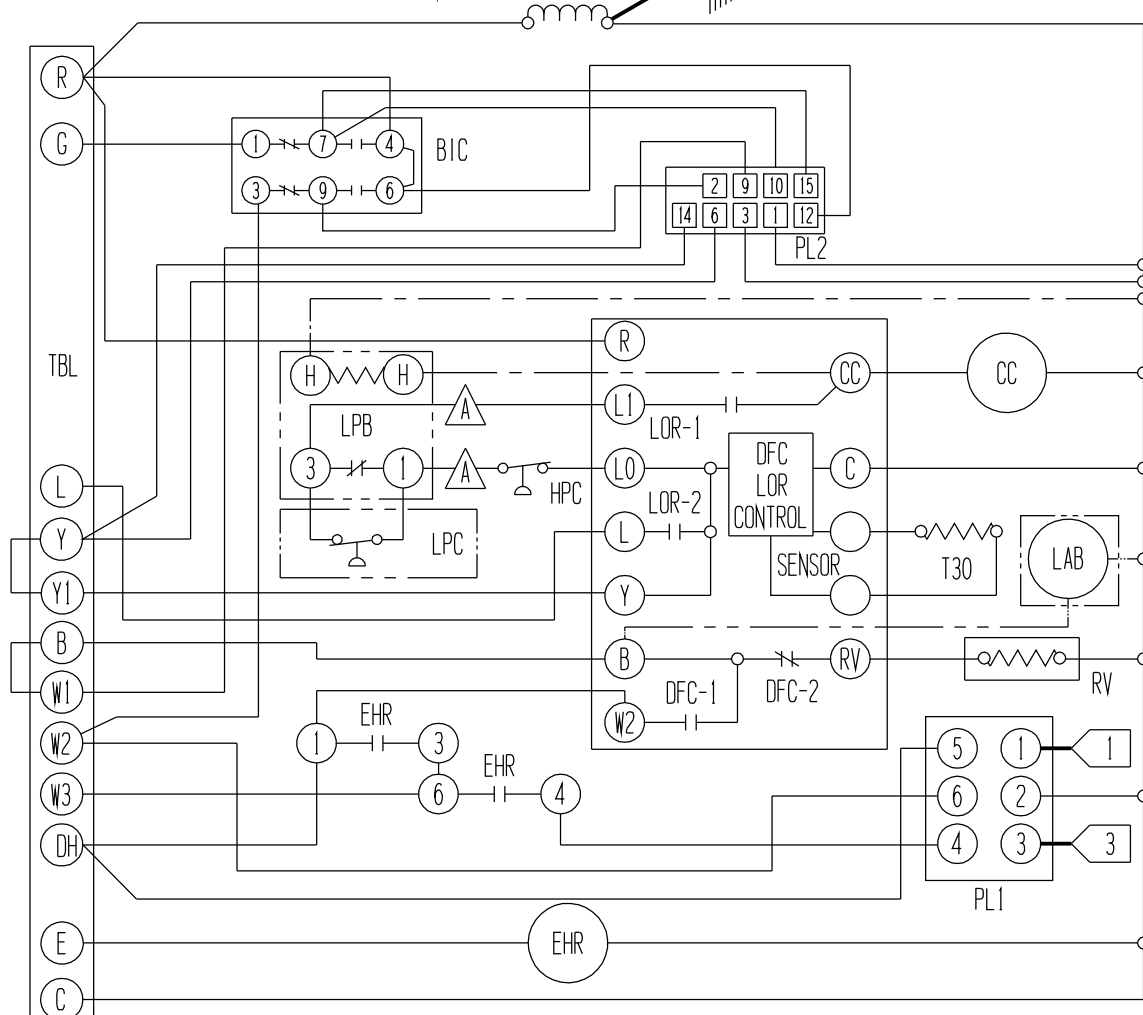
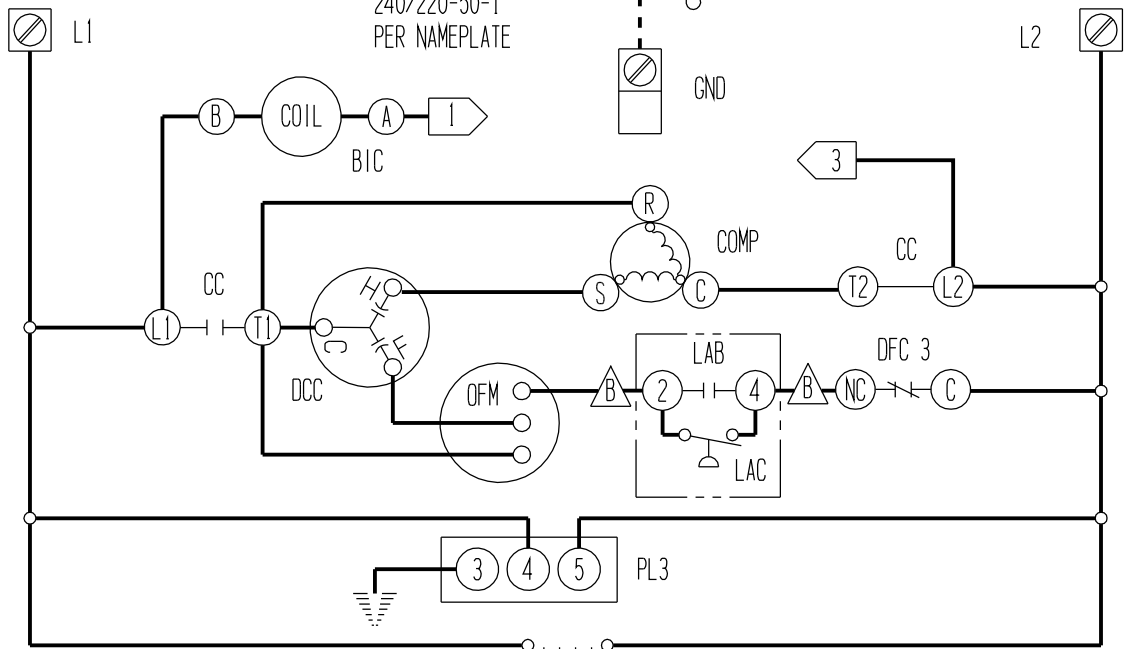

COMPONENT CODE			
BIC	BLOWER INTERLOCK RELAY	OFM	OUTDOOR FAN MOTOR
CC	COMPRESSOR CONTACTOR	PL1	PLUG #1
COMP	COMPRESSOR	PL2	PLUG #2
DCC	DUAL CAN CAPACITOR	PL3	PLUG #3
DFC	DEFROST CONTROL	RV	REV. VALVE SOLINOID
EHR	EMERGENCY HEAT RELAY	T	TRANSFORMER
GND	EQUIPMENT GROUND	TB	TERMINAL BLOCK
HPC	HIGH PRESSURE CONTROL	TBL	LOW VOLTAGE TERMINAL BLOCK
LAB	LOW AMBIENT BYPASS CONTROL		
LAC	LOW AMBIENT CONTROL		
LPB	LOW PRESSURE BYPASS		
LPC	LOW PRESSURE CONTROL		

	FACTORY STD.	FIELD	OPTIONAL	COLOR CODE							
HIGH VOLTAGE	————	-----	-----	BK	BLACK	Y	YELLOW	V	VIOLET	T	TAN
LOW VOLTAGE	————	-----	-----	BR	BROWN	G	GREEN	(PR)	PURPLE	PK	PINK
ACCESSORY	————	-----	-----	R	RED	BL	BLUE	GY	GRAY	L	LAVENDER
				O	ORANGE	W	WHITE	(S)	SLATE		

BARD MFG. CO.
4098-124 B

△, △ Labeled wires connect if no options used. △ MOVE ORANGE WIRE TO 208V TAP FOR 208V OPERATION

USE COPPER CONDUCTORS ONLY
SUITABLE FOR AT LEAST 75° C

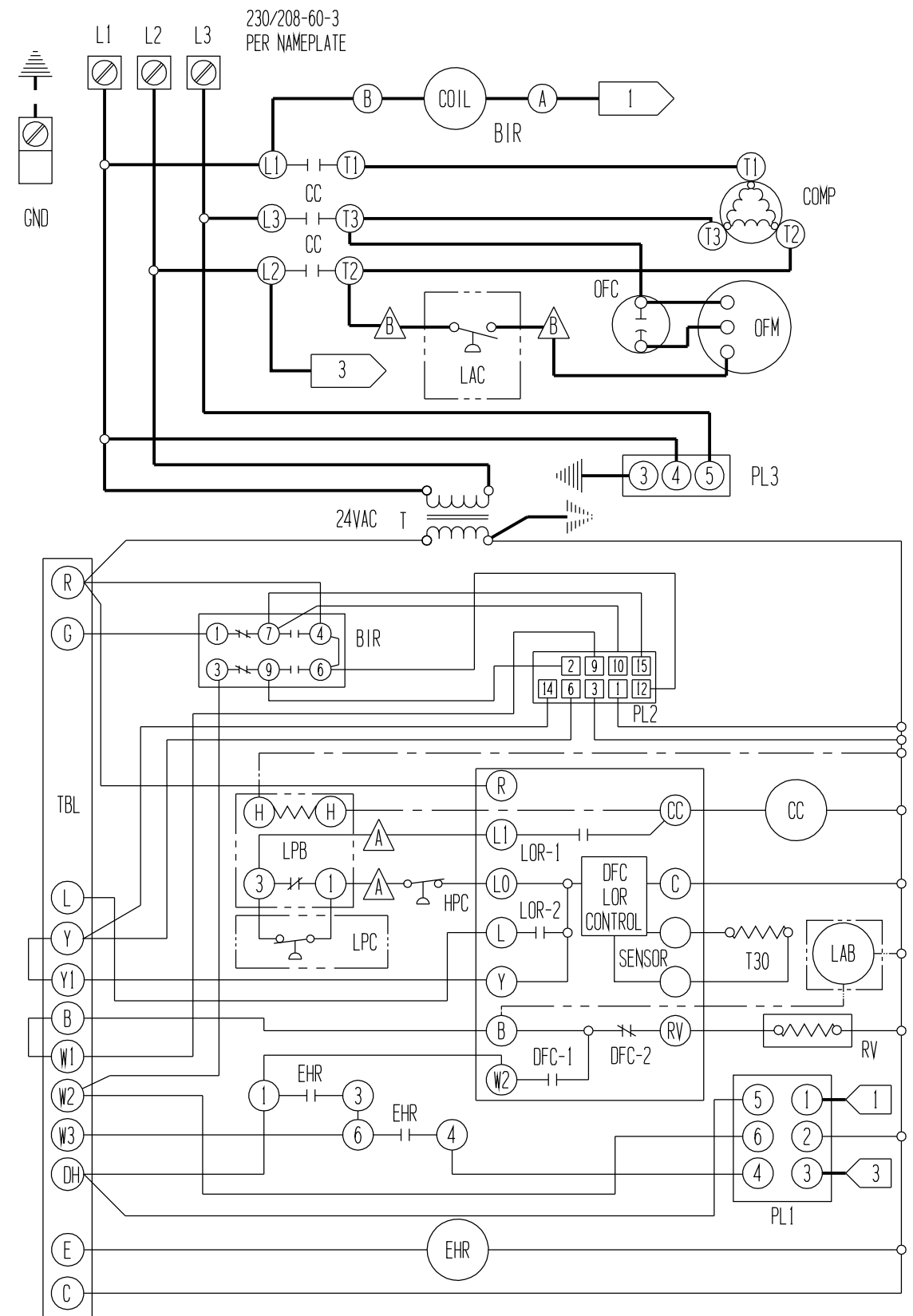
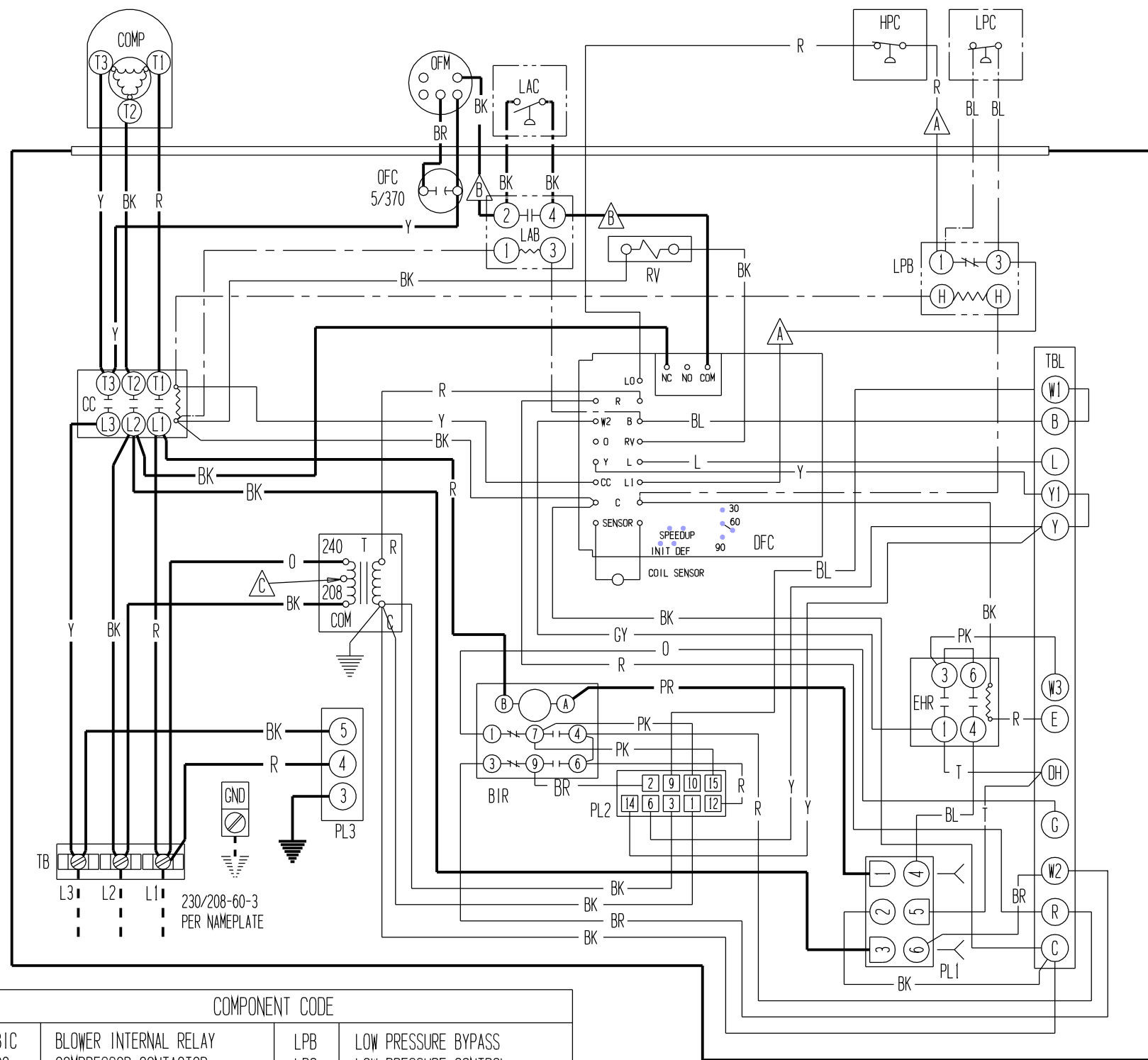

COMPONENT CODE			
BIC	BLOWER INTERNAL RELAY	LPB	LOW PRESSURE BYPASS
CC	COMPRESSOR CONTACTOR	LPC	LOW PRESSURE CONTROL
COMP	COMPRESSOR	OFM	OUTDOOR FAN MOTOR
DFC	DEFROST CONTROL	PL1	PLUG #1
EHR	EMERGENCY HEAT RELAY	PL2	PLUG #2
GND	EQUIPMENT GROUND	PL3	PLUG #3
HPC	HIGH PRESSURE CONTROL	RV	REV. VALVE SOLINOID
IBC	INDOOR BLOWER CAPACITOR	TCT	TOP CAP THERMOSTAT
IBM	INDOOR BLOWER MOTOR	T	TRANSFORMER
IBR	INDOOR BLOWER RELAY	TB	TERMINAL BLOCK
LAB	LOW AMBIENT BYPASS CONTROL	TBL	LOW VOLTAGE TERMINAL BLOCK
LAC	LOW AMBIENT CONTROL	OFC	OUTDOOR FAN CAPACITOR

, LABELED WIRES CONNECT IF NO OPTIONS USED. MOVE RED WIRE TO 208V TAP FOR 208V OPERATION

	FACTORY STD.	FIELD	OPTIONAL	COLOR CODE							
HIGH VOLTAGE				BK	BLACK	Y	YELLOW	V	VIOLET	T	TAN
LOW VOLTAGE				BR	BROWN	G	GREEN	(PR)	PURPLE	PK	PINK
ACCESSORY				R	RED	BL	BLUE	GY	GRAY	L	LAVENDER
				O	ORANGE	W	WHITE	(S)	SLATE		

BARD MFG. CO.
4098-211