
INSTALLATION INSTRUCTIONS

MOTORIZED FRESH AIR DAMPER

MODEL

WGMFAD-3

WGMFAD-5



CLIMATE CONTROL SOLUTIONS

Bard Manufacturing Company
Bryan, Ohio 43506

Since 1914...Moving ahead just as planned.

Manual : 2100-362B
Supersedes: 2100-362A
File: Volume III Tab 19
Date: 09-23-03

CONTENTS

Description 1
Application 1
Installation Instructions 2
Wiring Diagram 5

Figures

Figure 1 Vent Option Door 3
Figure 2 Exhaust Cover Plates 3
Figure 3A Routing of Wires 4
Figure 3B Proper Installation 4

Tables

Table 1 WGMFAD-3 Ventialtion Air 1
Table 2 WGMFAD-3 Ventialtion Air 2
Table 3 WGMFAD-5 Ventialtion Air 3

Manufactured under U.S. patent number:

5,485,878

DESCRIPTION

The motorized fresh air damper WGMFAD is an internally mounted damper designed to bring in up to 25% fresh air. The damper blade is powered by a 24 VAC motor with spring return on power loss. The damper is powered open anytime the unit blower motor is energized.

This ventilation device does not include an exhaust provision. Depending on the tightness of the structure, an independent exhaust provision may be needed to obtain the ventilation air quantities shown.

APPLICATION

The amount of outside fresh air brought into the structure is dependent on the supply and return duct static pressure present in the duct system. Refer to Table for ventilation air that will be supplied at different duct static pressure for the model installed.

For free blow applications with return air filter grille and supply grille use 0.00 supply air static pressure and 0.1 return air static pressure.

TABLE 1
WGMFAD-3 VENTILATION AIR
For use with WG24 Model

HIGH SPEED							
Supply Air Static	Ventilation Air / Total Air (CFM)						
0.00	150/1325	330/1300	480/1275	600/1240	680/1200	730/1140	750/1060
0.20	120/1190	310/1150	465/1130	580/1090	660/1035	700/985	720/925
0.40	110/1040	290/1000	440/940	550/880	640/845	690/760	NA
Return Static	0.00	0.05	0.10	0.15	0.20	0.25	0.30
MEDIUM SPEED							
Supply Air Static	Ventilation Air / Total Air (CFM)						
0.00	140/1130	300/1090	450/1075	570/1050	670/1000	720/940	740/850
0.20	110/1000	270/980	420/950	540/910	650/870	700/820	720/760
0.40	100/880	250/860	400/800	520/750	NA	NA	NA
Return Static	0.00	0.05	0.10	0.15	0.20	0.25	0.30
LOW SPEED							
Supply Air Static	Ventilation Air / Total Air (CFM)						
0.00	130/900	290/880	430/860	550/830	650/800	700/750	NA
0.20	100/820	250/790	400/730	520/700	NA	NA	NA
0.40	90/700	NA	NA	NA	NA	NA	NA
Return Static	0.00	0.05	0.10	0.15	0.20	0.25	0.30

TABLE 2
WGMFAD-3 VENTILATION AIR
For use with WG30 and WG36 Models

HIGH SPEED							
Supply Air Static							
0.00	160/1520	340/1490	490/1460	620/1420	725/1360	810/1330	870/1270
0.20	130/1340	320/1320	480/1270	610/1240	710/1140	780/1100	820/1050
0.40	120/1160	300/1140	450/1080	580/1020	680/930	760/820	NA
Return Static	0.00	0.05	0.10	0.15	0.20	0.25	0.30
MEDIUM SPEED							
Supply Air Static	Ventilation Air / Total Air (CFM)						
0.00	150/1325	330/1300	480/1275	600/1240	680/1200	730/1140	750/1060
0.20	120/1190	310/1150	465/1130	580/1090	660/1035	700/985	720/925
0.40	110/1040	290/1000	440/940	550/880	640/845	690/760	NA
Return Static	0.00	0.05	0.10	0.15	0.20	0.25	0.30
LOW SPEED							
Supply Air Static	Ventilation Air / Total Air (CFM)						
0.00	140/1130	300/1090	450/1075	570/1050	670/1000	720/940	740/850
0.20	110/1000	270/980	420/950	540/910	650/870	700/820	720/760
0.40	100/880	250/860	400/800	520/750	NA	NA	NA
Return Static	0.00	0.05	0.10	0.15	0.20	0.25	0.30

INSTALLATION

- Step 1. Disconnect all power to unit before installing WGMFAD.
- Step 2. Remove vent option door. (See Figure 1.) Remove fresh air damper or blank off plate if installed on vent option door.
- Step 3. The “exhaust cover plates” *must be* in place when a WGMFAD is installed. (See Figure 2.)

- Step 4. Install WGMFAD with notch in front lip of WGMFAD centered over hole in condenser partition. (See Figure 3A.)
- Step 5. Position WGMFAD with front lip over condenser partition and front grille. (See Figure 3B.) *This is important to insure proper drainage of any water entering damper assembly.*

TABLE 3
WGMFAD-5 VENTILATION AIR
For use with WG42, WG48 and WG60 Models

HIGH SPEED							
Supply Air Static	Ventilation Air / Total Air (CFM)						
0.00	140/1930	190/1910	235/1880	295/1840	355/1810	400/1770	440/1725
0.20	160/1650	205/1640	250/1625	335/1570	420/1515	450/1475	475/1430
0.40	175/1375	235/1340	295/1310	350/1240	465/1170	515/1085	565/1000
Return Static	0.00	0.05	0.10	0.15	0.20	0.25	0.30
MEDIUM SPEED							
Supply Air Static	Ventilation Air / Total Air (CFM)						
0.00	110/1615	160/1595	250/1575	300/1535	395/1500	450/1475	500/1445
0.20	130/1415	190/1380	270/1350	345/1300	380/1265	470/1200	555/1140
0.40	150/1135	215/1080	305/1030	375/965	475/895	540/790	600/680
Return Static	0.00	0.05	0.10	0.15	0.20	0.25	0.30
LOW SPEED							
Supply Air Static	Ventilation Air / Total Air (CFM)						
0.00	45/1190	150/1175	260/1165	350/1135	435/1105	530/1070	620/1030
0.20	65/1010	180/980	290/950	390/910	490/865	560/800	635/735
0.40	85/790	210/725	355/660	415/600	495/535	NA	NA
Return Static	0.00	0.05	0.10	0.15	0.20	0.25	0.30

Step 6. Route wires as shown in Figure 3A into unit low voltage terminal strip area.

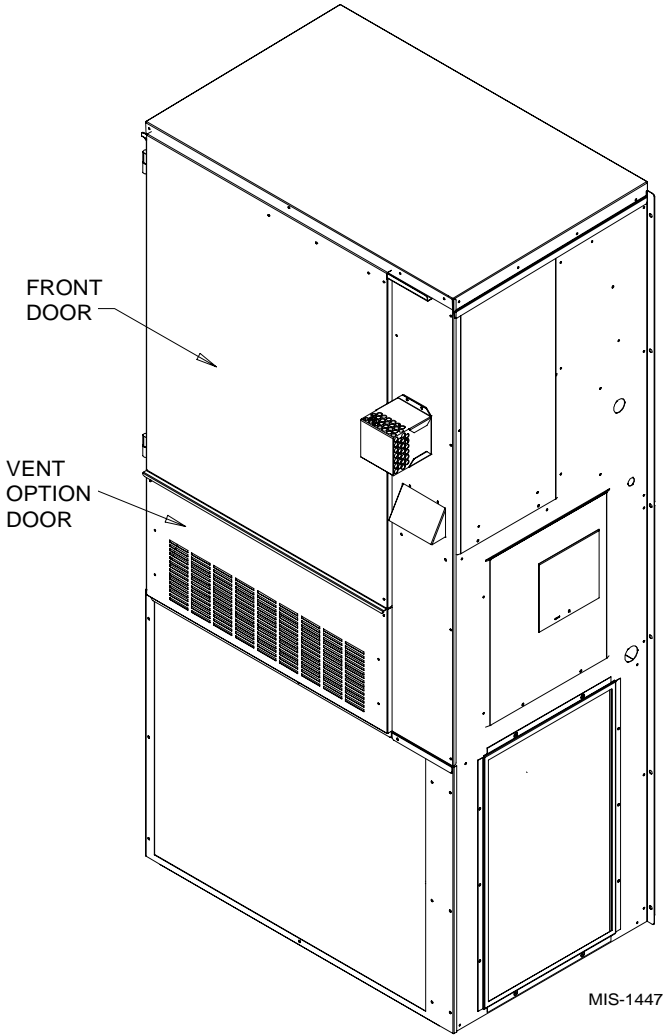
Step 7. Connect black wire to C terminal of low voltage block. Connect orange wire to G terminal of low voltage block. Connect blue wire to W1 terminal of low voltage block. See wall mount low voltage connection diagram in

the unit installation instructions for wiring diagram.

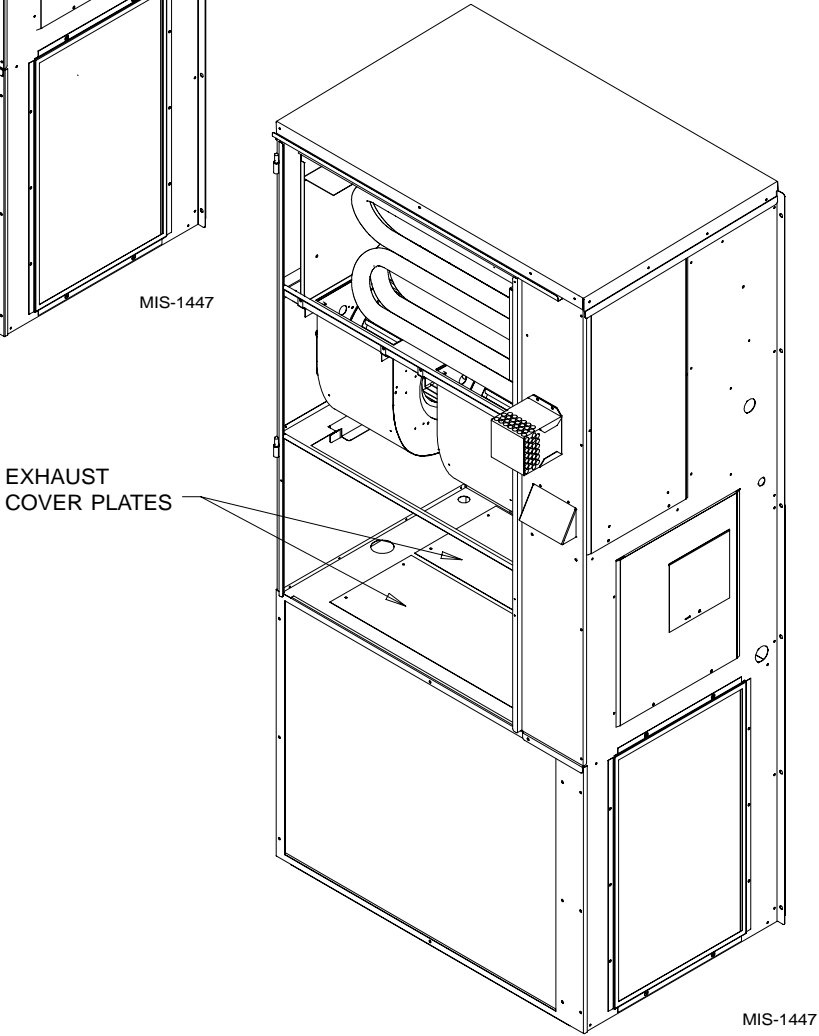
Step 8. Check WGMFAD for proper operation. WGMFAD should open whenever the blower is energized.

Step 9. Plug 4 holes in vent option door with plastic plugs provided and replace vent option door.

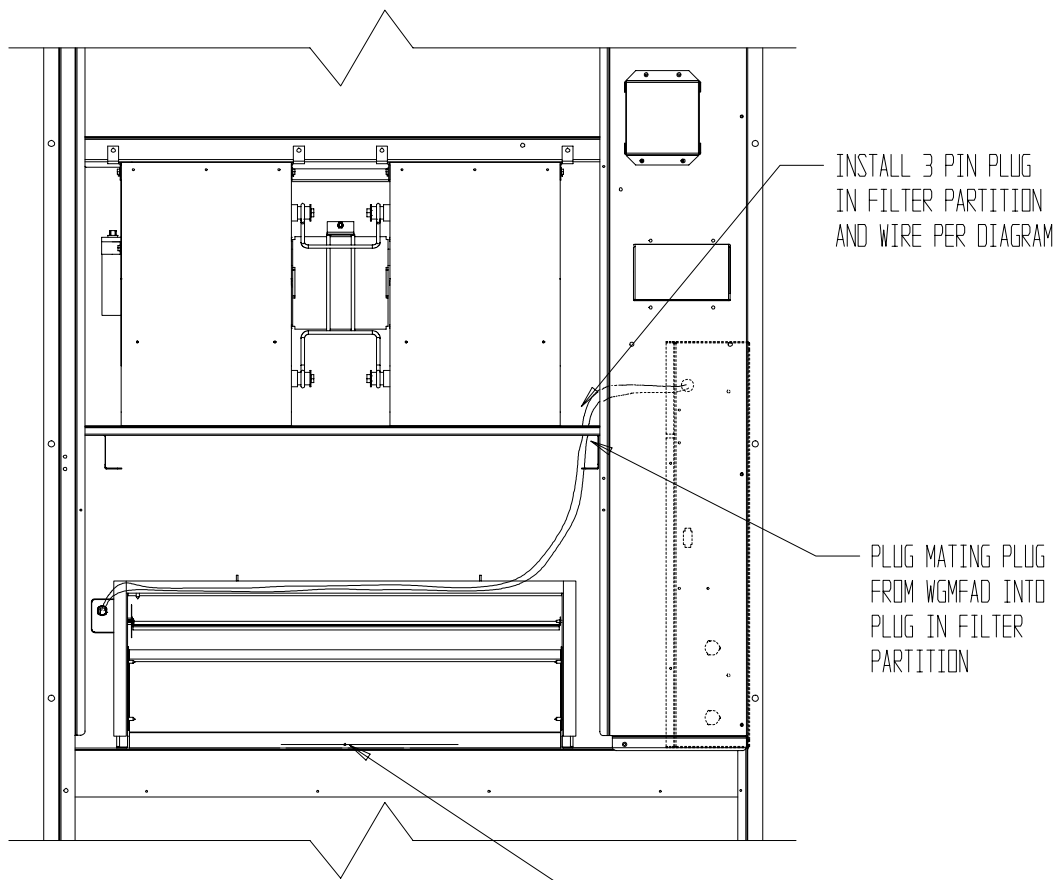
**FIGURE 1
VENT OPTION DOOR TO BE REMOVED**



**FIGURE 2
EXHAUST COVER PLATES
MUST BE IN PLACE**

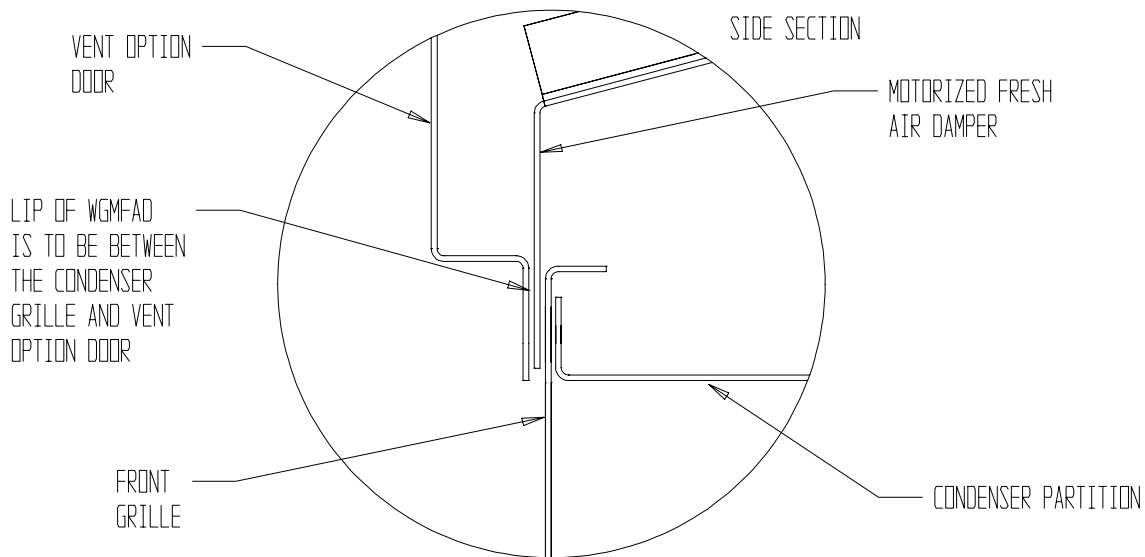


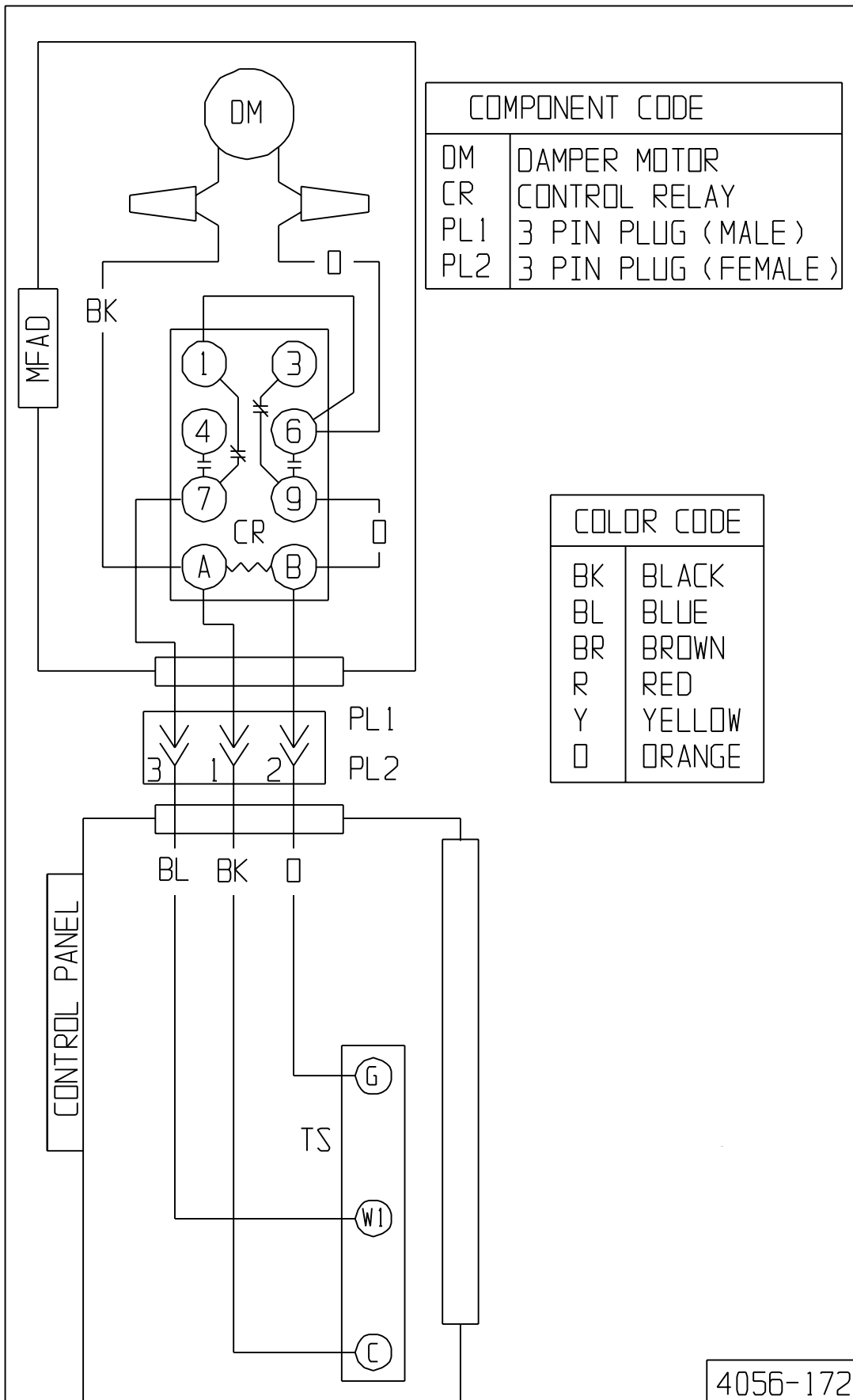
**FIGURE 3A
ROUTING OF WIRES**



WHEN INSTALLING WGMFAD POSITION SO THAT HOLE IN FRONT LIP IS CENTERED OVER HOLE IN CONDENSER GRILLE TO INSERT A SELF DRILLING SCREW

**FIGURE 3B
PROPER INSTALLATION**





4056-172