INSTALLATION INSTRUCTIONS

COMMERCIAL ROOM VENTILATORS WITH EXHAUST

MODELS

WGCRVS-3

WGCRVP-3

WGCRVS-5

WGCRVP-5



Bard Manufacturing Company
Bryan, Ohio 43506

Since 1914...Moving ahead just as planned

Manual : 2100-363B
Supersedes: 2100-363A
File: Volume III Tab 19
Date: 01-16-02

Contents

WG General Information

General Information	1
Unpacking	1
Discription	1
Features	1
Sequence of Operation	1

Installation Instructions

Basic Installation	4
Wiring Diagrams	17 & 18

Figures

Figure 1	Sequence of Operation - Call for Blower Operation	2
Figure 2	Sequence of Operation - On Loss of Blower Operation	3
Figure 3	Removal of Vent Option Panel	4
Figure 4	Removal of Front Exhaust Cover Plate	5
Figure 5	Installation of CRV Plate	5
Figure 6	Installation of Ventilator	6

Tables

Table 1	WGCRV-3 Ventilation Air – Free Blow Application	8
Table 2A	WGCRV-3 Ventilation Air – High Speed	9
Table 2B	WGCRV-3 Ventilation Air – Medium High Speed	10
Table 2C	WGCRV-3 Ventilation Air – Medium Low Speed	11
Table 2D	WGCRV-3 Ventilation Air – Low Speed	12
Table 3	WGCRV-5 Ventilation Air – Free Blow Application	13
Table 4A	WGCRV-5 Ventilation Air – High Speed	14
Table 4B	WGCRV-5 Ventilation Air – Medium Speed	15
Table 4C	WGCRV-5 Ventilation Air – Low Speed	16

GENERAL INFORMATION

The ventilator should only be installed by a trained heating and air conditioning technician. These instructions serve as a guide to the technician installing the ventilator package. They are not intended as a step by step procedure with which the mechanically incline owner can install the package.

The ventilator housing is shipped in one carton which contains the electrical harness, miscellaneous hardware and installation instructions.

UNPACKING

Upon receipt of the equipment be sure to compare the model number found on the shipping label with the accessory identification information on the ordering and shipping document to verify that the correct accessory has been shipped.

Inspect the carton housing of each ventilator as it is received, and before signing the freight bill verify that all items have been received and that there is no visible damage. Note any shortages or damage on all copies of the freight bill. The receiving party must contact the last carrier immediately, preferably in writing, requesting inspection by the carrier's agent. Concealed damage not discovered until after loading must be reported to the carrier within 15 days of its receipt.

DESCRIPTION

The ventilators are designed to be used with Bard 2 ton through 5 ton wall mount gas electric units. They are electromechanical vent systems designed to provide fresh air to meet indoor air quality standards with built in exhaust provisions.

COMMERCIAL ROOM VENTILATOR

FEATURES:

- One piece construction – easy to install with no mechanical linkage adjustment required.
- Exhaust air damper – built in with positive closed position. Provides exhaust air capability to prevent pressurization of tight buildings.
- **CRVS Model** Actuator motor – 24 volt, power open, spring return with built in torque limiting switch.
- **CRVP Model** Actuator motor – 24 volt, power open, power close with built in torque limiting switch.
- Provides up to 75 percent of outside air.

COMMERCIAL ROOM VENTILATOR SEQUENCE OF OPERATION

On a call for blower operation, CRV opens to full open position as set by minimum position potentiometer. See Figure 1.

A call for cooling cycles the compressor and dampers remain in the ventilation mode. On loss of blower operation, CRV closes fully. See Figure 2.

FIGURE 1
SEQUENCE OF OPERATION
CALL FOR BLOWER OPERATION

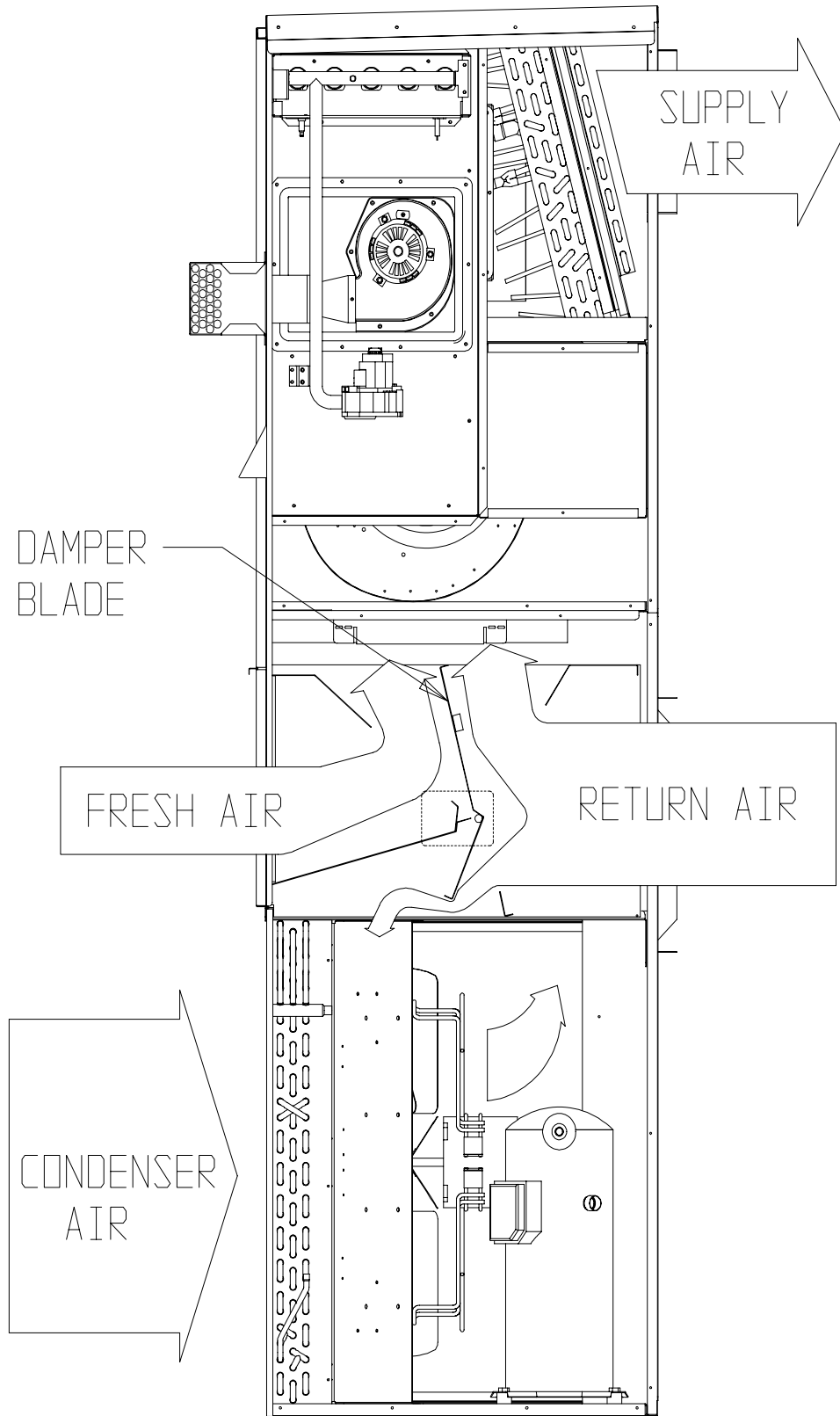

MIS-1465

FIGURE 2
SEQUENCE OF OPERATION
ON LOSS OF BLOWER OPERATION

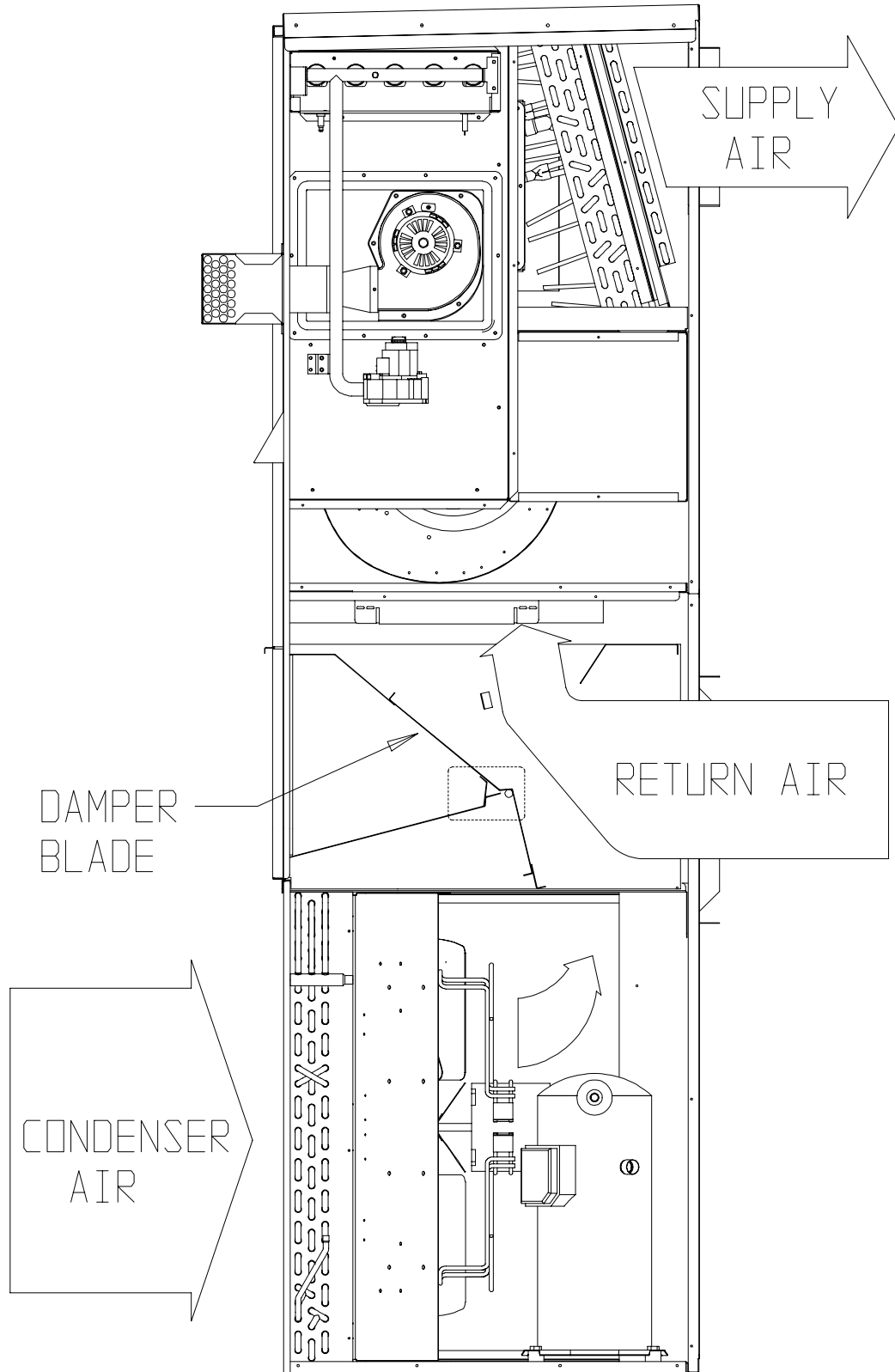

MIS-1466

INSTALLATION INSTRUCTIONS

BASIC INSTALLATION

1. Unpack the ventilator assembly which includes the integral ventilator with attached electrical harness and miscellaneous hardware.

WARNING

Open and lock unit disconnect switch before installing this accessory to prevent injury or death due to electrical shock or contact with moving parts. Turn thermostat to off.

2. Open the front door, and remove and save vent option panel on the Bard Wall mount units. (See Figure 3.)

3. Remove and save existing unit air filter and screw from front center grille. (See Figure 4.)
4. Remove and discard the front exhaust cover plate. (See Figure 4.)
5. Install ventilator by inserting the ventilator into the unit. (See Figure 6.)

IMPORTANT: Position front lip of ventilator on top of front grille and condenser partition. (See Figure 6 Inset.) This is important to ensure proper drainage of any water entering damper assembly.

6. Open control panel to gain access to unit low voltage terminal block.

FIGURE 3

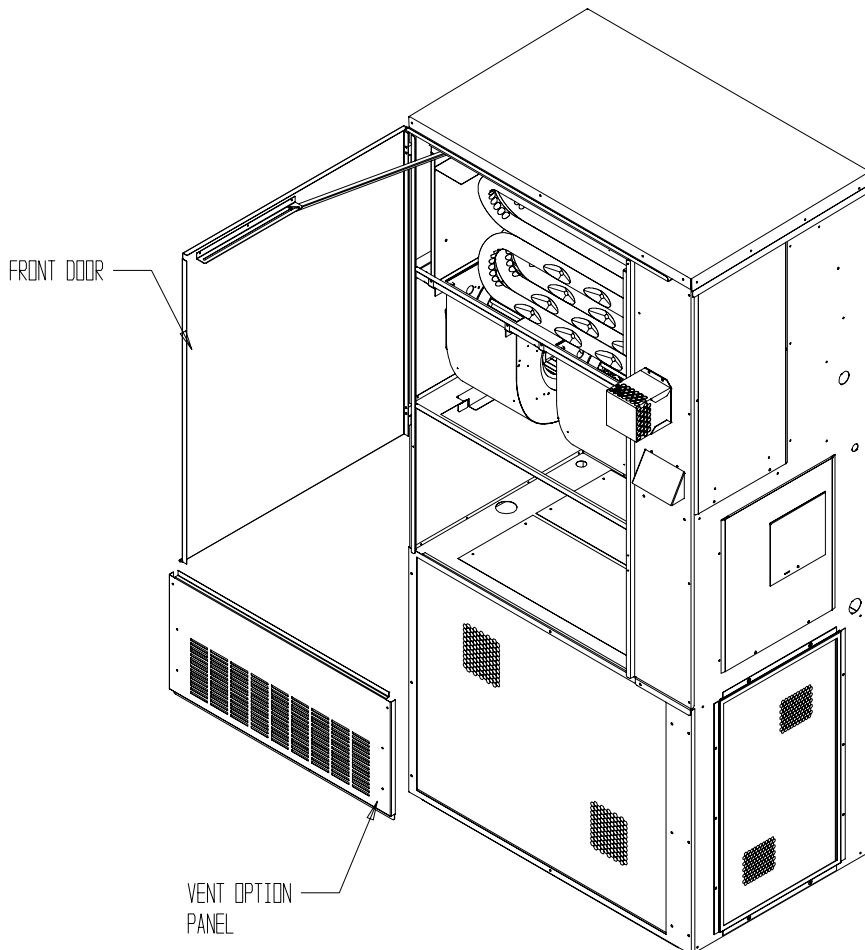

MIS-1448

FIGURE 4

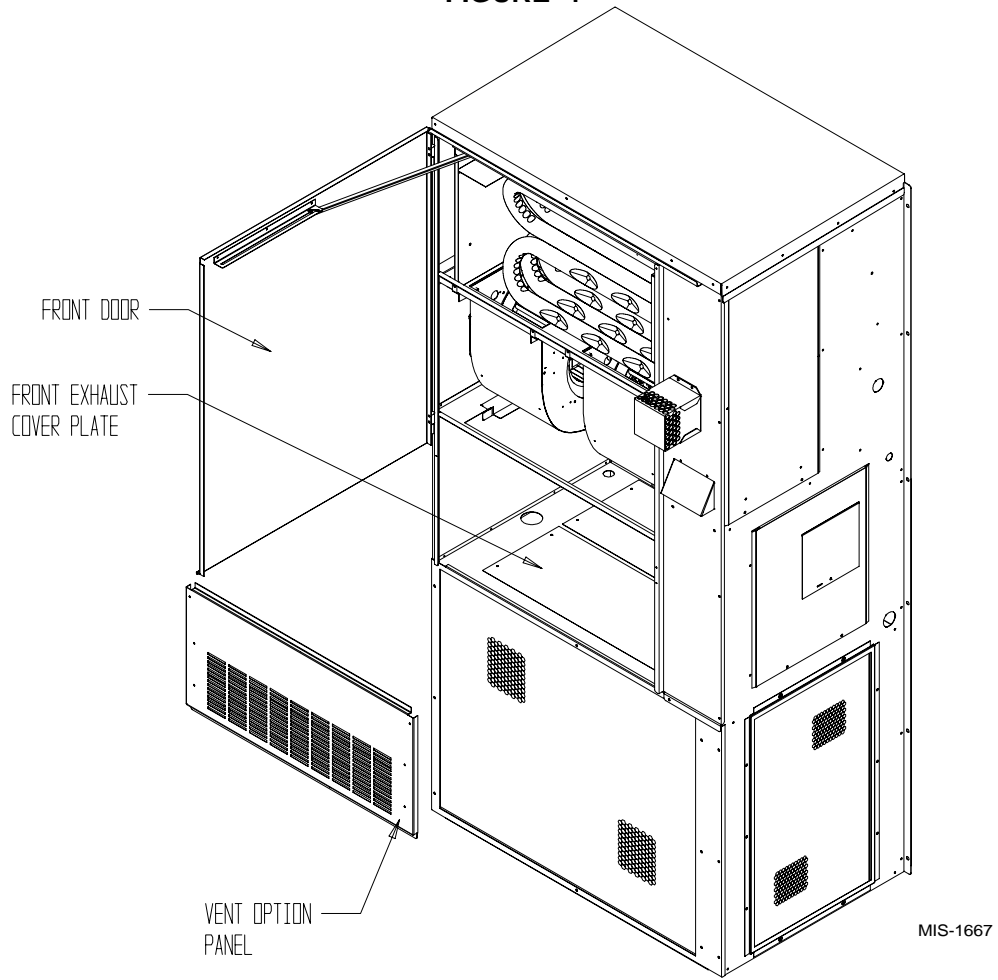
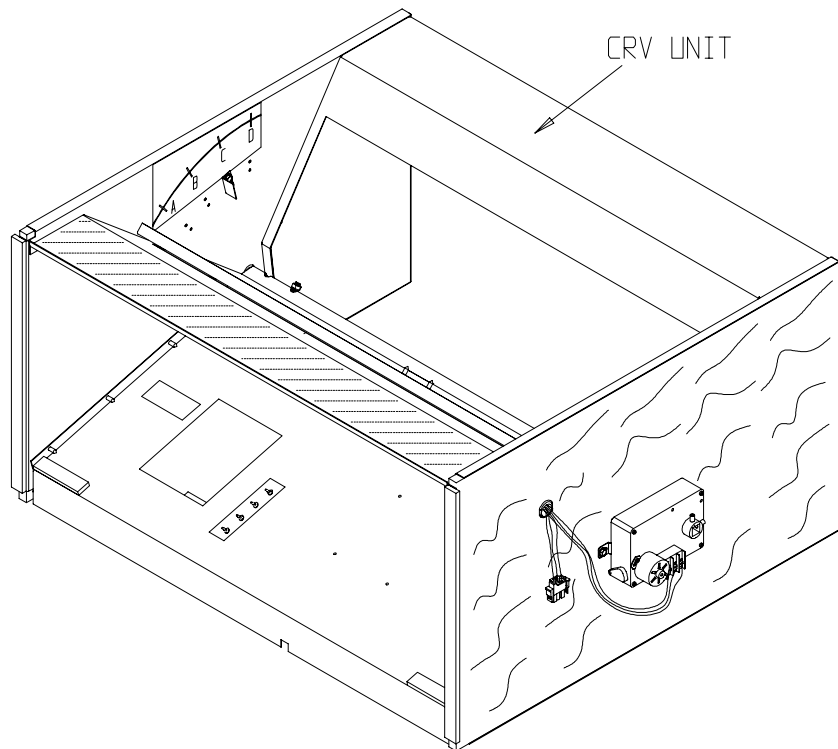

FIGURE 5



MIS-1483

FIGURE 6

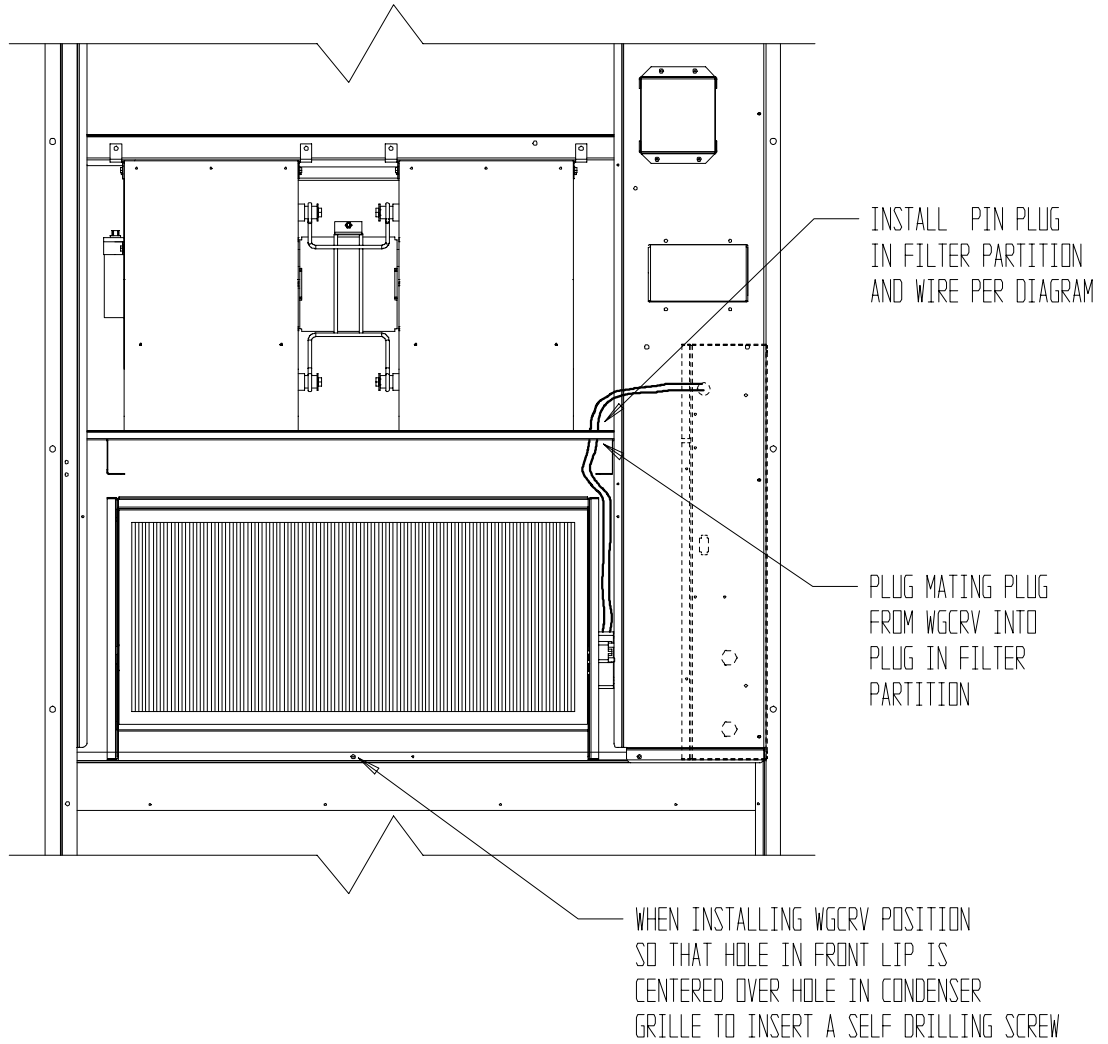
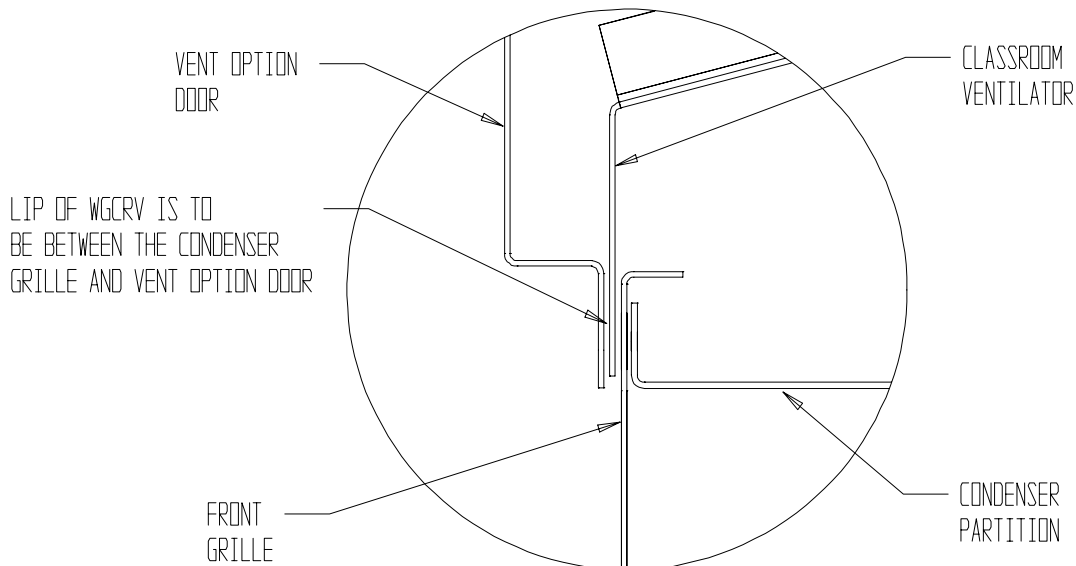

FIGURE 6 INSET



MIS-1464

7. Route electrical harness leads through the 7/8" bushing in control panel (Figure 6) into low voltage box.
8. Connect leads with fork terminal to corresponding points on terminal strip. (See wiring diagrams later in this manual or on ventilator.) Plug connector into corresponding hole in filter rack.
9. Close control panel cover.
10. Plug mating connector from CRV into connector in filter rack.
11. Blade adjustment for desired ventilator air. The amount of ventilation air supplied by the commercial room ventilator is dependent on four (4) factors.
 - a. Return air duct static pressure drop.
 - b. Supply air duct static pressure drop.
 - c. Indoor blower motor speed
 - d. Damper blade open position setting.

To determine the amount of fresh air that will be supplied to the structure first, determine the pressure drops of the supply and return air ducts. For free blow application with return air filter grille and supply grille, assume .05 supply static, .10 return static. See Table for unit installed.

Determine on what speed the evaporator motor is running.

Refer to the tables on the following pages to determine the blade setting necessary to achieve the ventilation air required at the supply and return static duct pressure drops that are applicable.

NOTE: The ventilation air shown in the tables on the following pages is without the condenser fan running. When the condenser fan is running, the ventilation air will increase slightly.

12. Ventilator Checkout

CRVS Models (only)

- a. Remove mist eliminator to allow access to minimum position thumbwheel. (See Figures 6 and 7.)
- b. Resupply power to unit.
- c. Energize the evaporator blower by switching thermostat to the manual fan position with heat/cool in OFF position.
- d. Ventilator should open to the position set by position adjustment thumbwheel. Cycle position adjustment thumbwheel to full open through full close. Observe damper blade operation throughout travel to assure free, unobstructed movement. (See Figure 7.)
- e. Adjust position adjustment thumbwheel until desired blade setting is reached with power applied to unit. See Tables for the unit installed for required blade setting versus ventilator air.
- f. De-energize the evaporator blower. Damper blade should close.
- g. This completes ventilator checkout for CRVS models.

CRVP Models (only)

- a. Locate blade stop and reposition to location that will allow the desired airflow from Table for the unit installed.
- b. Resupply power to unit.
- c. Energize the evaporation blower by switching thermostat to the manual fan position with heat/cool in OFF position.
- d. Ventilation blade should open until it contacts the blade stop.
- e. De-energize evaporator blower. Damper blade should close.
- f. This completes the ventilation checkout for CRVP models.

TABLE 1
WGCRV-3 VENTILATION AIR
FREE BLOW APPLICATION WITH SUPPLY AND RETURN GRILLES

High Speed @ 0.05 Supply Air Static	
Damper Position	Ventilation Air / Total Air (CFM)
"A"	310 / 1390
"B"	445 / 1400
"C"	525 / 1390
Return Static	0.10
Medium High Speed @ 0.05 Supply Air Static	
Damper Position	Ventilation Air / Total Air (CFM)
"A"	300 / 1225
"B"	410 / 1235
"C"	475 / 1210
Return Static	0.10
Medium Low Speed @ 0.05 Supply Air Static	
Damper Position	Ventilation Air / Total Air (CFM)
"A"	385 / 1050
"B"	370 / 1070
"C"	425 / 1070
Return Static	0.10
Low Speed @ 0.05 Supply Air Static	
Damper Position	Ventilation Air / Total Air (CFM)
"A"	260 / 850
"B"	345 / 840
"C"	400 / 840
Return Static	0.10

**TABLE 2A
WGCRV-3 VENTILATION AIR – HIGH SPEED**

HIGH SPEED	0.00 SUPPLY AIR STATIC						
Damper Position	Ventilation Air / Total Air (CFM)						
"A"	180/1500	200/1480	220/1460	240/1400	270/1370	300/1300	330/1290
"B"	360/1490	380/1460	410/1430	440/1390	470/1360	500/1290	520/1285
"C"	540/1480	560/1440	600/1400	640/1375	675/1350	700/1270	730/1280
Return Static	0.00	0.05	0.10	0.15	0.20	0.25	0.30
HIGH SPEED	0.20 SUPPLY AIR STATIC						
Damper Position	Ventilation Air / Total Air (CFM)						
"A"	175/1330	190/1320	210/1310	220/1275	250/1225	280/1160	320/1100
"B"	340/1310	360/1300	390/1285	420/1250	450/1210	480/1150	510/1090
"C"	500-1300	520/1280	570/1260	610/1230	625/1200	650/1140	720/1080
Return Static	0.00	0.05	0.10	0.15	0.20	0.25	0.30
HIGH SPEED	0.40 SUPPLY AIR STATIC						
Damper Position	Ventilation Air / Total Air (CFM)						
"A"	140/1160	155/1130	165/1100	180/1050	230/990	260/930	300/870
"B"	280/1150	300/1120	320/1095	350/1030	410/970	440/910	480/850
"C"	420/1140	440/1110	470/1090	510/1010	590/950	620/890	690/830
Return Static	0.00	0.05	0.10	0.15	0.20	0.25	0.30

**TABLE 2B
WGCRV-3 VENTILATION AIR – MEDIUM HIGH SPEED**

MEDIUM HIGH SPEED	0.00 SUPPLY AIR STATIC						
Damper Position	Ventilation Air / Total Air (CFM)						
"A"	155/1360	175/1320	195/1290	215/1260	240/1220	260/1180	290/1150
"B"	320/1340	340/1300	370/1280	400/1250	440/1210	480/1170	530/1140
"C"	480/1320	500/1280	540/1270	580/1240	640/1200	700/1160	780/1130
Return Static	0.00	0.05	0.10	0.15	0.20	0.25	0.30
MEDIUM HIGH SPEED	0.20 SUPPLY AIR STATIC						
Damper Position	Ventilation Air / Total Air (CFM)						
"A"	125/1190	145/1160	180/1140	200/1110	220/1080	240/1040	270/1010
"B"	270/1180	290/1150	350/1130	370/1100	410/1065	420/1025	450/990
"C"	420/1170	440/1140	520/1120	540/1090	600/1050	620/1010	650/970
Return Static	0.00	0.05	0.10	0.15	0.20	0.25	0.30
MEDIUM HIGH SPEED	0.40 SUPPLY AIR STATIC						
Damper Position	Ventilation Air / Total Air (CFM)						
"A"	120/1040	135/1020	170/1000	190/925	200/850	220/800	250/760
"B"	250/1030	270/1010	330/955	350/890	385/840	400/780	430/740
"C"	385/1020	400/1000	490/910	510/860	570/830	590/760	620/720
Return Static	0.00	0.05	0.10	0.15	0.20	0.25	0.30

**TABLE 2C
WGCRV-3 VENTILATION AIR – MEDIUM LOW SPEED**

MEDIUM LOW SPEED	0.00 SUPPLY AIR STATIC						
Damper Position	Ventilation Air / Total Air (CFM)						
"A"	140/1160	160/1125	180/1095	200/1010	230/1050	250/1035	280/1025
"B"	270/1135	320/1100	360/1085	390/1050	420/1040	440/1025	460/1010
"C"	400/1110	470/1075	530/1075	580/140	620/1030	650/1010	670/990
Return Static	0.00	0.05	0.10	0.15	0.20	0.25	0.30
MEDIUM LOW SPEED	0.20 SUPPLY AIR STATIC						
Damper Position	Ventilation Air / Total Air (CFM)						
"A"	120/1020	140/980	170/960	190/930	200/880	220/860	250/840
"B"	250/1010	280/970	330/950	360/920	390/870	410/850	430/830
"C"	380/1000	420/960	500/940	520/910	580/860	600/840	630/820
Return Static	0.00	0.05	0.10	0.15	0.20	0.25	0.30
MEDIUM LOW SPEED	0.40 SUPPLY AIR STATIC						
Damper Position	Ventilation Air / Total Air (CFM)						
"A"	100/870	120/830	160/810	180/760	780/710	NA	NA
"B"	210/860	240/520	310/800	340/750	NA	NA	NA
"C"	325/850	340/810	440/790	460/740	NA	NA	NA
Return Static	0.00	0.05	0.10	0.15	0.20	0.25	0.30

**TABLE 2D
WGCRV-3 VENTILATION AIR – LOW SPEED**

LOW SPEED	0.00 SUPPLY AIR STATIC						
Damper Position	Ventilation Air / Total Air (CFM)						
"A"	110/940	140/920	170/900	185/880	200/860	220/840	240/820
"B"	220/930	270/910	320/890	360/870	400/850	430/830	460/810
"C"	330/920	390/900	450/880	500/860	550/840	590/820	630/800
Return Static	0.00	0.05	0.10	0.15	0.20	0.25	0.30
LOW SPEED	0.20 SUPPLY AIR STATIC						
Damper Position	Ventilation Air / Total Air (CFM)						
"A"	100/830	130/810	160/780	170/760	190/680	NA	NA
"B"	200/820	250/800	300/770	340/750	NA	NA	NA
"C"	300/810	360/790	430/760	NA	NA	NA	NA
Return Static	0.00	0.05	0.10	0.15	0.20	0.25	0.30
LOW SPEED	0.40 SUPPLY AIR STATIC						
Damper Position	Ventilation Air / Total Air (CFM)						
"A"	90/710	110/680	NA	NA	NA	NA	NA
"B"	170/700	NA	NA	NA	NA	NA	NA
"C"	250/690	NA	NA	NA	NA	NA	NA
Return Static	0.00	0.05	0.10	0.15	0.20	0.25	0.30

TABLE 3
WGCRV-5 VENTILATION AIR
FREE BLOW APPLICATION WITH SUPPLY AND RETURN GRILLES

High Speed @ 0.05 Supply Air Static	
Damper Position	Ventilation Air / Total Air (CFM)
"A"	240 / 1780
"B"	430 / 1760
"C"	540 / 1710
"D"	650 / 1630
Return Static	0.10
Medium High Speed @ 0.05 Supply Air Static	
Damper Position	Ventilation Air / Total Air (CFM)
"A"	180 / 1480
"B"	385 / 1450
"C"	480 / 1410
"D"	600 / 1375
Return Static	0.10
Low Speed @ 0.05 Supply Air Static	
Damper Position	Ventilation Air / Total Air (CFM)
"A"	145 / 1110
"B"	335 / 1100
"C"	390 / 1070
"D"	500 / 1050
Return Static	0.10

**TABLE 4A
WGCRV-5 VENTILATION AIR – HIGH SPEED**

HIGH SPEED	0.00 SUPPLY AIR STATIC						
Damper Position	Ventilation Air / Total Air (CFM)						
"A"	240/1895	250/1870	260/1845	280/1820	300/1790	330/1760	360/1740
"B"	435/1870	445/1850	460/1830	480/1815	500/1780	530/1750	560/1735
"C"	560/1815	570/1795	585/1775	605/1760	625/1725	655/1700	675/1685
"D"	680/1730	690/1715	705/1700	725/1690	745/1660	770/1630	785/1615
Return Static	0.00	0.05	0.10	0.15	0.20	0.25	0.30
HIGH SPEED	0.20 SUPPLY AIR STATIC						
Damper Position	Ventilation Air / Total Air (CFM)						
"A"	205/1615	220/1600	235/1575	265/1560	285/1530	320/1500	355/1430
"B"	380/1605	400/1590	410/1565	425/1550	445/1520	500/1480	540/1420
"C"	490/1560	510/1545	520/1510	535/1495	560/1460	610/1430	640/1385
"D"	590/1460	610/1445	635/1415	645/1400	675/1360	710/1340	730/1300
Return Static	0.00	0.05	0.10	0.15	0.20	0.25	0.30
HIGH SPEED	0.40 SUPPLY AIR STATIC						
Damper Position	Ventilation Air / Total Air (CFM)						
"A"	180/1315	195/1300	220/1275	250/1240	270/1170	310/1120	355/1045
"B"	315/1305	330/1280	350/1250	395/1210	415/1140	455/1090	540/1015
"C"	410/1245	425/1220	440/1190	485/1155	505/1090	555/1020	600/985
"D"	495/1165	515/1145	530/1105	555/1090	575/1020	615/990	660/935
Return Static	0.00	0.05	0.10	0.15	0.20	0.25	0.30

**TABLE 4B
WGCRV-5 VENTILATION AIR – MEDIUM SPEED**

MEDIUM SPEED	0.00 SUPPLY AIR STATIC						
Damper Position	Ventilation Air / Total Air (CFM)						
"A"	165/1540	180/1535	195/1530	220/1525	250/1510	295/1495	340/1475
"B"	360/1525	375/1515	390/1505	420/1500	450/1480	495/1460	540/1440
"C"	470/1490	485/1480	500/1470	530/1465	560/1440	605/1420	625/1400
"D"	590/1455	615/1445	630/1440	650/1430	670/1400	715/1380	735/1365
Return Static	0.00	0.05	0.10	0.15	0.20	0.25	0.30
MEDIUM SPEED	0.20 SUPPLY AIR STATIC						
Damper Position	Ventilation Air / Total Air (CFM)						
"A"	125/1325	150/1310	170/1290	200/1275	230/1250	280/1200	330/1170
"B"	320/1310	345/1295	370/1275	390/1260	420/1230	480/1175	535/1155
"C"	405/1270	430/1255	455/1235	470/1220	500/1180	550/1150	590/1120
"D"	505/1225	530/1200	555/1185	580/1175	610/1150	630/1120	680/1080
Return Static	0.00	0.05	0.10	0.15	0.20	0.25	0.30
MEDIUM SPEED	0.40 SUPPLY AIR STATIC						
Damper Position	Ventilation Air / Total Air (CFM)						
"A"	120/1060	140/1020	185/1000	190/985	220/920	280/860	300/700
"B"	255/1045	275/1005	315/980	370/955	410/880	460/800	520/670
"C"	325/1000	355/960	390/940	435/920	480/850	520/750	580/660
"D"	410/960	440/940	470/900	505/885	535/815	580/710	600/635
Return Static	0.00	0.05	0.10	0.15	0.20	0.25	0.30

**TABLE 4C
WGCRV-5 VENTILATION AIR – LOW SPEED**

LOW SPEED	0.00 SUPPLY AIR STATIC						
Damper Position	Ventilation Air / Total Air (CFM)						
"A"	75/1190	110/1180	150/1165	190/1150	235/1130	290/1100	340/1075
"B"	270/1165	305/1150	345/1140	390/1130	435/1100	490/1070	540/1055
"C"	325/1140	360/1130	400/1125	430/1110	475/1090	530/1060	560/1040
"D"	445/1120	480/1110	520/1100	550/1090	595/1070	640/1040	655/1025
Return Static	0.00	0.05	0.10	0.15	0.20	0.25	0.30
LOW SPEED	0.20 SUPPLY AIR STATIC						
Damper Position	Ventilation Air / Total Air (CFM)						
"A"	55/995	90/970	130/950	160/925	205/890	280/870	330/840
"B"	230/980	265/955	305/940	370/910	415/870	480/850	520/820
"C"	285/955	320/925	360/910	390/895	435/850	510/810	550/790
"D"	385/930	420/910	460/900	495/880	540/840	590/790	610/760
Return Static	0.00	0.05	0.10	0.15	0.20	0.25	0.30
LOW SPEED	0.40 SUPPLY AIR STATIC						
Damper Position	Ventilation Air / Total Air (CFM)						
"A"	40/740	75/700	115/650	140/600	NA	NA	NA
"B"	180/730	215/680	255/630	360/585	NA	NA	NA
"C"	210/710	245/660	290/610	380/570	NA	NA	NA
"D"	290/690	325/650	375/590	450/560	NA	NA	NA
Return Static	0.00	0.05	0.10	0.15	0.20	0.25	0.30

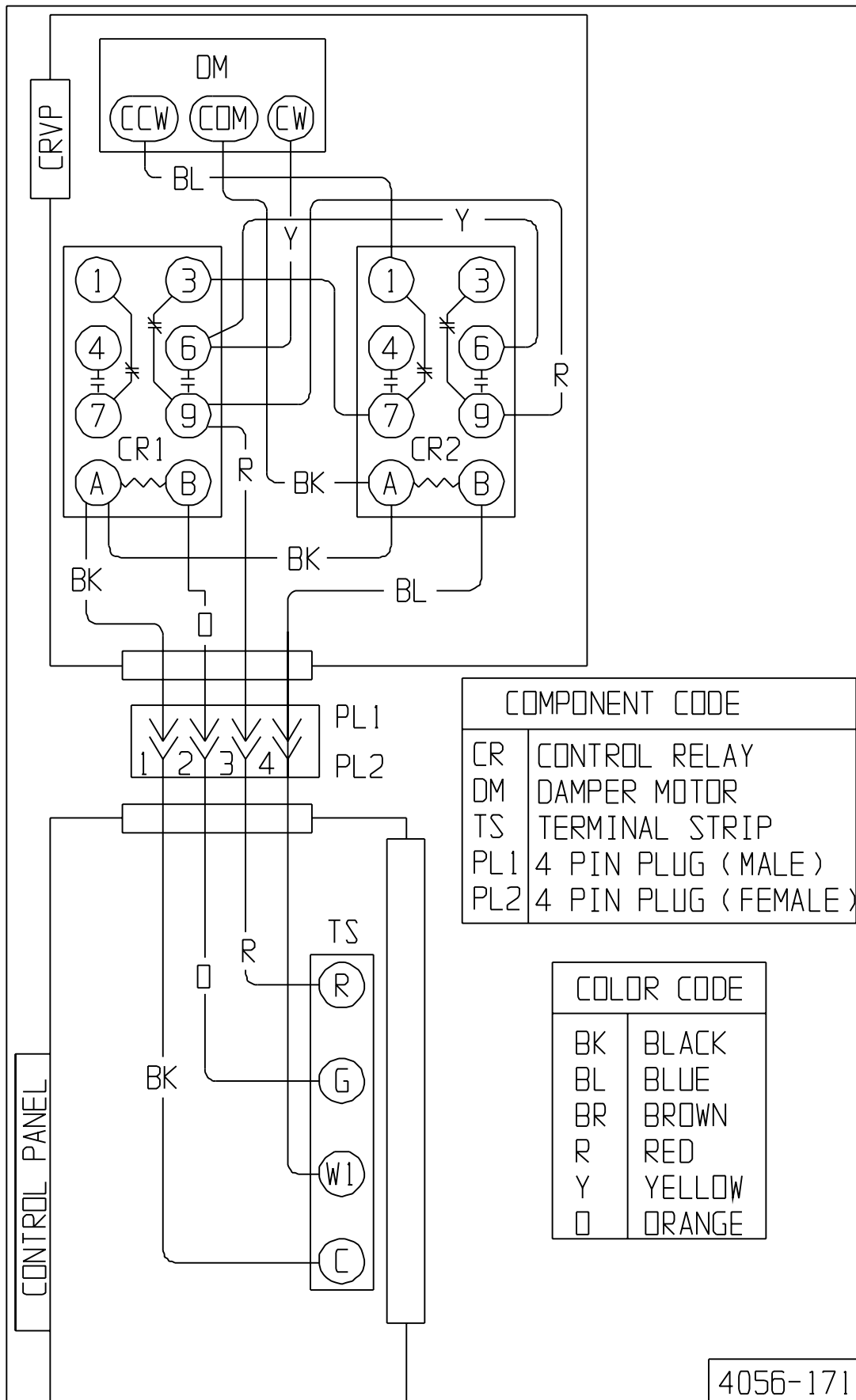

COMPONENT CODE	
CR	CONTROL RELAY
DM	DAMPER MOTOR
TS	TERMINAL STRIP
PL1	4 PIN PLUG (MALE)
PL2	4 PIN PLUG (FEMALE)

COLOR CODE	
BK	BLACK
BL	BLUE
BR	BROWN
R	RED
Y	YELLOW
O	ORANGE

4056-171

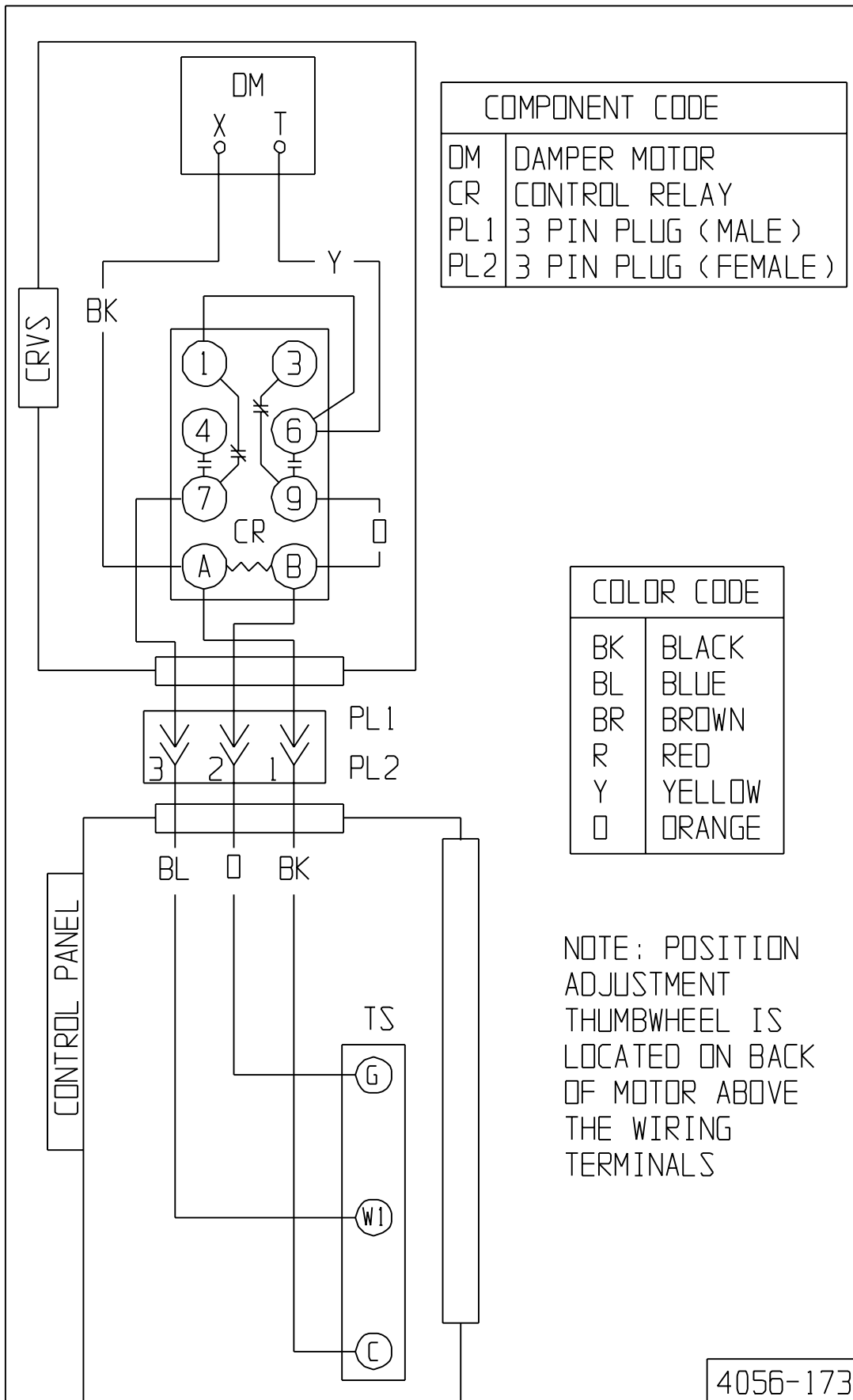

COMPONENT CODE	
DM	DAMPER MOTOR
CR	CONTROL RELAY
PL1	3 PIN PLUG (MALE)
PL2	3 PIN PLUG (FEMALE)

COLOR CODE	
BK	BLACK
BL	BLUE
BR	BROWN
R	RED
Y	YELLOW
O	ORANGE

NOTE: POSITION ADJUSTMENT THUMBWHEEL IS LOCATED ON BACK OF MOTOR ABOVE THE WIRING TERMINALS

4056-173