INSTALLATION INSTRUCTIONS

ENERGY RECOVERY VENTILATOR WITH EXHAUST

MODELS:
WGERV-A3A
WGERV-C3A
WGERV-A5A
WGERV-C5A
WGSERV-A5
WGSERV-C5



Bard Manufacturing Company, Inc.
Bryan, Ohio 43506
Since 1914...Moving ahead, just as planned.

Manual: 2100-364J
Supersedes: 2100-364I
File: Volume III, Tab 19
Date: 05-16-08

CONTENTS

Model Nomenclature Legend	3	Basic Installation (Field Installation)	8 & 9
Electrical Specifications	3	Basic Installation (Factory Installed Versions)	21
General Description	3	Control Wiring	21
General Information	3	Control Requirements	21
Unpacking	3	Recommended Control Sequences	21
Performance and Application Data - WGERV-A3	4	Ventilation Airflow	21
Performance and Application Data - WGERV-C3	5	Energy Recovery Ventilator Maintenance	22
Performance & Application Data - WGERV-A5/ WGSERV-A5	6	Maintenance Procedures	22
Performance & Application Data - WGERV-C5/ WGSERV-C5	7	Quarterly & Annual Maintenance	23
		Wiring Diagrams	26-27

Figures

Figure 1 Intake Hood Assembly	9
Figure 2 Remove Vent Option Door	10
Figure 3 Filter & Exhaust Plate Location	11
Figure 4A Installation of Exhaust Blower Assembly ...	12
Figure 4B Installation of Exhaust Blower Assembly ...	13
Figure 5 Installation of WGERV	14
Figure 6 WGERV Assembly	15
Figure 7 Wiring - 230 Volt	16
Figure 8 Wiring - 460 Volt	17
Figure 9 Wiring - All WGSERV	18
Figure 10 Fresh Air Intake Hood Assy	19
Figure 11 Operation w/WGERV Installed	20
Figure 12 Terminal Block Location Diagram	24
Figure 13 Hub Assembly with Ball Bearings	25

Tables

Table 1 Ventilation Air (CFM)	22
-------------------------------------	----

**COPYRIGHT APRIL 2004
BARD MANUFACTURING COMPANY, INC.
BRYAN, OHIO USA 43506**

Manufactured under the following U.S. patent numbers:
5,485,878; 5,0023,116; 4,924,934;
4,875,520; 4,825,936

MODEL NOMENCLATURE LEGEND

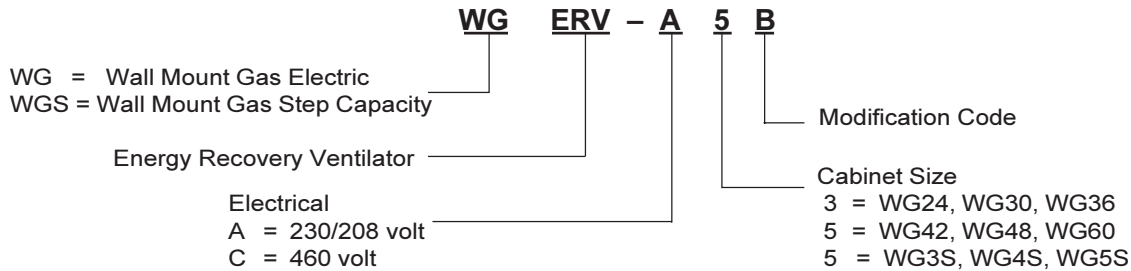

ELECTRICAL SPECIFICATIONS

Model	Voltage	Amps	Control Voltage
WGERV-A3 WGERV-A5 WGSERV-A5	230/208	2.1	24V
WGERV-C3 WGERV-C5 WGSERV-C5	460	1.1	24V

NOTE: Never set intake blower at a lower speed than the exhaust blower, as it will create a negative pressure in the room.

GENERAL DESCRIPTION

The Energy Recovery Ventilator was designed to provide energy efficient, cost effective ventilation to meet I.A.Q. (Indoor Air Quality) requirements while still maintaining good indoor comfort and humidity control for a variety of applications such as schools, classrooms, lounges, conference rooms, beauty salons and others. It provides a constant supply of fresh air for control of airborne pollutants including CO₂, smoke, radon, formaldehyde, excess moisture, virus and bacteria.

The ventilator incorporates patented rotary heat exchanger technology to remove both heat and moisture.

It is designed as a single package, which can be easily factory or field installed for new installations or retrofit to Bard WG/WGS wall mounted units. The package consists of a unique rotary Energy Recovery Cassette that can be easily removed for cleaning or maintenance. The cassette has a 21-inch diameter heat transfer wheel for efficient heat transfer. The heat transfer wheel uses a permanently bonded dry desiccant coating for total heat recovery.

Ventilation is accomplished with two (2) blower/motor assemblies each consisting of a drive motor and dual blowers for maximum ventilation at low sound levels. On non-independent motor control models, the air is exhausted at the same rate that fresh air is brought into the structure, thus not impacting building pressure. On independent motor control models, the air can be exhausted at a different rate than the intake or fresh air. Never operate the fresh air at a lower speed than the exhaust air. Operating the fresh air at a higher speed than the exhaust air will help maintain a slight positive pressure in the building. The rotating energy wheel provides the heat transfer effectively during both summer and winter conditions. Provides required ventilation to meet the requirements of ASHRAE 62.1 Standard.

GENERAL INFORMATION

The ventilator should only be installed by a trained heating and air conditioning technician. These instructions serve as a guide to the technician installing the ventilator package. They are not intended as a step-by-step procedure with which the mechanically-inclined owner can install the package.

The ventilator housing is shipped in one carton, which contains the following:

1. Energy Recovery Ventilator
2. Service Door
3. Rain Hood and Mist Eliminator
4. Installation Instructions

UNPACKING

Upon receipt of the equipment, be sure to compare the model number found on the shipping label with the accessory identification information on the ordering and shipping document to verify that the correct accessory has been shipped.

Inspect the carton housing of each ventilator as it is received, and before signing the freight bill, verify that all items have been received and that there is no visible damage. Note any shortages or damage on all copies of the freight bill. The receiving party must contact the last carrier immediately, preferably in writing, requesting inspection by the carrier's agent. Concealed damage not discovered until after loading must be reported to the carrier within 15 days of its receipt.

APPLICATION DATA – WGERV-A3
SUMMER COOLING PERFORMANCE
(INDOOR DESIGN CONDITIONS 75°DB/63°WB)

Ambient O.D.	VENTILATION RATE -- 450 CFM High Speed (Black) 72% EFFICIENCY						VENTILATION RATE -- 370 CFM Medium Speed (Blue) 73% EFFICIENCY						VENTILATION RATE -- 280 CFM Low Speed (Red) 74% EFFICIENCY						
	DB/ WB	F	VLT	VLS	VLL	HRT	HRS	HRL	VLT	VLS	VLL	HRT	HRS	HRL	VLT	VLS	VLL	HRT	HRS
105	75	21465	14580	6885	15455	10500	4955	17650	11990	5660	12885	8750	4135	13350	8750	4600	9880	6710	3170
	70	14580	14580	0	10500	10500	0	11990	11990	0	8750	8750	0	9070	8750	320	6710	6710	0
	65	14580	14580	0	10500	10500	0	11990	11990	0	8750	8750	0	9070	8750	320	6710	6710	0
100	80	31500	12150	19350	22680	8750	13930	25900	9990	15910	18910	7295	11615	19600	7290	12310	14500	5395	9105
	75	21465	12150	9315	15455	8750	6705	17650	9990	7660	12885	7295	5590	13355	7290	6065	9885	5395	4490
	70	12350	12150	200	8890	8750	140	10160	9990	170	7415	7295	120	7685	7290	395	5685	5395	290
	65	12150	12150	0	8750	8750	0	9990	9990	0	7295	7295	0	7290	7290	0	5395	5395	0
	60	12150	12150	0	8750	8750	0	9990	9990	0	7295	7295	0	7290	7290	0	5395	5395	0
95	80	31590	9720	21870	22745	7000	15745	25975	7990	17985	18960	5835	13125	19655	5830	13825	14545	4315	10230
	75	21465	9720	11745	15455	7000	8455	17650	7990	9660	12885	5835	7050	13355	5830	7525	9885	4315	5570
	70	12350	9720	2630	8890	7000	1890	10150	7990	2160	7410	5835	1575	7685	5830	1855	5685	4315	1370
	65	9720	9720	0	7000	7000	0	7990	7990	0	5835	5835	0	5830	5830	0	4315	4315	0
	60	9720	9720	0	7000	7000	0	7990	7990	0	5835	5835	0	5830	5830	0	4315	4315	0
90	80	31590	7290	24300	22745	5250	17495	25975	5995	19980	18960	4376	14584	19655	4375	15280	14545	3240	11305
	75	21465	7290	14175	15455	5250	10205	17650	5995	11655	12885	4376	8508	13355	4375	8980	9885	3240	6645
	70	12350	7290	5060	8890	5250	3640	10155	5995	4160	7415	4376	3039	7685	4375	3310	5685	3240	2445
	65	7290	7290	0	5250	5250	0	5995	5995	0	4376	4376	0	4375	4375	0	3240	3240	0
	60	7290	7290	0	5250	5250	0	5995	5995	0	4376	4376	0	4375	4375	0	3240	3240	0
85	80	31590	4860	26730	22745	3500	19245	25975	3995	21980	18962	2916	16045	19655	2915	16740	14545	2155	12390
	75	21465	4860	16605	15455	3500	11955	17650	3995	13655	12885	2916	9968	13355	2915	10440	9885	2155	7730
	70	12350	4860	7490	8892	3500	5392	10155	3995	6160	7415	2916	4499	7685	2915	4770	5685	2155	3530
	65	4860	4860	0	3500	3500	0	3995	3995	0	2916	2916	0	2915	2915	0	2155	2155	0
	60	4860	4860	0	3500	3500	0	3995	3995	0	2916	2916	0	2915	2915	0	2155	2155	0
80	75	21465	2430	19035	15455	1750	13705	17650	2000	15650	12885	1460	11425	13355	1460	11895	9885	1080	8805
	70	12350	2430	9920	8892	1750	7142	10150	2000	8150	7410	1460	5950	7685	1460	6225	5685	1080	4605
	65	4250	2430	1820	3060	1750	1310	3500	2000	1500	2555	1460	1095	2645	1460	1185	1960	1080	880
	60	2430	2430	0	1750	1750	0	2000	2000	0	1460	1460	0	1460	1460	0	1080	1080	0
75	70	12350	0	12350	8892	3060	5832	10150	0	10150	7410	2550	4860	7685	0	7685	5685	1955	3730
	65	4250	0	4250	3060	0	3060	3495	0	3495	2550	0	2550	2645	0	2645	1955	0	1955

LEGEND:

- VLT = Ventilation Load – Total
- VLS = Ventilation Load – Sensible
- VLL = Ventilation Load – Latent
- HRT = Heat Recovery – Total
- HRS = Heat Recovery – Sensible
- HRL = Heat Recovery – Latent
- WVL = Winter Ventilation Load
- WHR = Winter Heat Recovery

WINTER HEATING PERFORMANCE
(INDOOR DESIGN CONDITIONS 70°F DB)

Ambient O.D.	VENTILATION RATE					
	450 CFM 76% EFF.		370 CFM 78% EFF.		280 CFM 80% EFF.	
DB/°F	WVL	WHR	WVL	WHR	WVL	WHR
65	2430	1850	2000	1560	1510	1210
60	4860	3690	4000	3120	3020	2420
55	7290	5540	5990	4680	4540	3630
50	9720	7390	7990	6230	6050	4840
45	12150	9230	9990	7790	7560	6050
40	14580	11080	11990	9350	9070	7260
35	17010	12930	13990	10910	10580	8470
30	19440	14770	15980	12470	12100	9680
25	21870	16620	17980	14030	13610	10890
20	24300	18470	19980	15580	15120	12100
15	26730	20320	21980	17140	16630	13310

NOTE: Sensible performance only is shown for winter application.

APPLICATION DATA – WGERV-C3
SUMMER COOLING PERFORMANCE
(INDOOR DESIGN CONDITIONS 75°DB/63°WB)

Ambient O.D.		VENTILATION RATE -- 450 CFM High Speed (Black) 72% EFFICIENCY						VENTILATION RATE -- 370 CFM Low Speed (Red) 73% EFFICIENCY					
DB/ WB	F	VLT	VLS	VLL	HRT	HRS	HRL	VLT	VLS	VLL	HRT	HRS	HRL
105	75	21465	14580	6885	15455	10500	4955	17650	11990	5660	12885	8750	4135
	70	14580	14580	0	10500	10500	0	11990	11990	0	8750	8750	0
	65	14580	14580	0	10500	10500	0	11990	11990	0	8750	8750	0
100	80	31500	12150	19350	22680	8750	13930	25900	9990	15910	18910	7295	11615
	75	21465	12150	9315	15455	8750	6705	17650	9990	7660	12885	7295	5590
	70	12350	12150	200	8890	8750	140	10160	9990	170	7415	7295	120
	65	12150	12150	0	8750	8750	0	9990	9990	0	7295	7295	0
	60	12150	12150	0	8750	8750	0	9990	9990	0	7295	7295	0
95	80	31590	9720	21870	22745	7000	15745	25975	7990	17985	18960	5835	13125
	75	21465	9720	11745	15455	7000	8455	17650	7990	9660	12885	5835	7050
	70	12350	9720	2630	8890	7000	1890	10150	7990	2160	7410	5835	1575
	65	9720	9720	0	7000	7000	0	7990	7990	0	5835	5835	0
	60	9720	9720	0	7000	7000	0	7990	7990	0	5835	5835	0
90	80	31590	7290	24300	22745	5250	17495	25975	5995	19980	18960	4376	14584
	75	21465	7290	14175	15455	5250	10205	17650	5995	11655	12885	4376	8508
	70	12350	7290	5060	8890	5250	3640	10155	5995	4160	7415	4376	3039
	65	7290	7290	0	5250	5250	0	5995	5995	0	4376	4376	0
	60	7290	7290	0	5250	5250	0	5995	5995	0	4376	4376	0
85	80	31590	4860	26730	22745	3500	19245	25975	3995	21980	18962	2916	16045
	75	21465	4860	16605	15455	3500	11955	17650	3995	13655	12885	2916	9968
	70	12350	4860	7490	8892	3500	5392	10155	3995	6160	7415	2916	4499
	65	4860	4860	0	3500	3500	0	3995	3995	0	2916	2916	0
	60	4860	4860	0	3500	3500	0	3995	3995	0	2916	2916	0
80	75	21465	2430	19035	15455	1750	13705	17650	2000	15650	12885	1460	11425
	70	12350	2430	9920	8892	1750	7142	10150	2000	8150	7410	1460	5950
	65	4250	2430	1820	3060	1750	1310	3500	2000	1500	2555	1460	1095
	60	2430	2430	0	1750	1750	0	2000	2000	0	1460	1460	0
75	70	12350	0	12350	8892	3060	5832	10150	0	10150	7410	2550	4860
	65	4250	0	4250	3060	0	3060	3495	0	3495	2550	0	2550

LEGEND:

- VLT = Ventilation Load – Total
- VLS = Ventilation Load – Sensible
- VLL = Ventilation Load – Latent
- HRT = Heat Recovery – Total
- HRS = Heat Recovery – Sensible
- HRL = Heat Recovery – Latent
- WVL = Winter Ventilation Load
- WHR = Winter Heat Recovery

WINTER HEATING PERFORMANCE
(INDOOR DESIGN CONDITIONS 70°F DB)

Ambient O.D.	VENTILATION RATE			
	450 CFM 76% EFF.		370 CFM 78% EFF.	
DB/°F	WVL	WHR	WVL	WHR
65	2430	1850	2000	1560
60	4860	3690	4000	3120
55	7290	5540	5990	4680
50	9720	7390	7990	6230
45	12150	9230	9990	7790
40	14580	11080	11990	9350
35	17010	12930	13990	10910
30	19440	14770	15980	12470
25	21870	16620	17980	14030
20	24300	18470	19980	15580
15	26730	20320	21980	17140

NOTE: Sensible performance only is shown for winter application.

APPLICATION DATA – WGERV-A5 / WGSERV-A5

SUMMER COOLING PERFORMANCE (INDOOR DESIGN CONDITIONS 75°DB/63°WB)

Ambient O.D.	VENTILATION RATE -- 450 CFM High Speed (Black) 60% EFFICIENCY						VENTILATION RATE -- 370 CFM Medium Speed (Blue) 62% EFFICIENCY						VENTILATION RATE -- 280 CFM Low Speed (Red) 64% EFFICIENCY							
	DB/ WB	F	VLT	VLS	VLL	HRT	HRS	HRL	VLT	VLS	VLL	HRT	HRS	HRL	VLT	VLS	VLL	HRT	HRS	HRL
105	75	21465	14580	6884	12879	8748	4131	17649	11988	5661	10942	7433	3510	13356	9072	4284	8548	5806	2742	
	70	14580	14580	0	8748	8748	0	11988	11988	0	7433	7433	0	9072	9072	0	5806	5806	0	
	65	14580	14580	0	8748	8748	0	11988	11988	0	7433	7433	0	9072	9072	0	5806	5806	0	
100	80	31500	12150	19440	18900	7290	11610	25900	9990	15910	16058	6194	9864	19600	7560	12040	12544	4838	7706	
	75	21465	12150	9314	12879	7290	5589	17649	9990	7659	10942	6194	4749	13356	7560	5796	8548	4838	3709	
	70	12352	12150	202	7411	7290	121	10156	9990	166	6297	6194	103	7686	7560	126	4919	4838	80	
	65	12150	12150	0	7290	7290	0	9990	9990	0	6194	6194	0	7560	7560	0	4838	4838	0	
	60	12150	12150	0	7290	7290	0	9990	9990	0	6194	6194	0	7560	7560	0	4838	4838	0	
95	80	31590	9720	21870	18954	5832	13122	25974	7992	17982	16104	4955	11149	19656	6048	13608	12580	3871	8709	
	75	21465	9720	11744	12879	5832	7047	17649	7992	9657	10942	4955	5987	13356	6048	7308	8548	3871	4677	
	70	12352	9720	2632	7411	5832	1579	10156	7992	2164	6297	4955	1342	7686	6048	1638	4919	3871	1048	
	65	9720	9720	0	5832	5832	0	7992	7992	0	4955	4955	0	6048	6048	0	3871	3871	0	
	60	9720	9720	0	5832	5832	0	7992	7992	0	4955	4955	0	6048	6048	0	3871	3871	0	
90	80	31590	7290	24300	18954	4374	14580	25974	5994	19980	16104	3716	12388	19656	4536	15120	12580	2903	9677	
	75	21465	7290	14175	12879	4374	8505	17649	5994	11655	10942	3716	7226	13356	4536	8820	8548	2903	5645	
	70	12352	7290	5062	7411	4374	3037	10156	5994	4162	6297	3716	2580	7686	4536	3150	4919	2903	2016	
	65	7290	7290	0	4374	4374	0	5994	5994	0	3716	3716	0	4536	4536	0	2903	2903	0	
	60	7290	7290	0	4374	4374	0	5994	5994	0	3716	3716	0	4536	4536	0	2903	2903	0	
85	80	31590	4860	26730	18954	2916	16038	25974	3996	21978	16104	2478	13626	19656	3024	16632	12580	1935	10644	
	75	21465	4860	16605	12879	2916	9963	17649	3996	13653	10942	2478	8465	13356	3024	10332	8548	1935	6612	
	70	12352	4860	7492	7411	2916	4495	10156	3996	6160	6297	2478	3819	7686	3024	4662	4919	1935	2983	
	65	4860	4860	0	2916	2916	0	3996	3996	0	2478	2478	0	3024	3024	0	1935	1935	0	
	60	4860	4860	0	2916	2916	0	3996	3996	0	2478	2478	0	3024	3024	0	1935	1935	0	
80	75	21465	2430	19035	12879	1458	11421	17649	1998	15651	10942	1239	9704	13356	1512	11844	8548	968	7580	
	70	12352	2430	9922	7411	1458	5953	10156	1998	8158	6297	1239	5058	7686	1512	6174	4919	968	3951	
	65	4252	2430	1822	2551	1458	1093	3496	1998	1498	2168	1239	929	2646	1512	1134	1693	968	726	
	60	2430	2430	0	1458	1458	0	1998	1998	0	1239	1239	0	1512	1512	0	968	968	0	
75	70	12352	0	12352	7411	0	7411	10156	0	10156	6297	0	6297	7686	0	7686	4919	0	4919	
	65	4252	0	4252	2551	0	2551	3496	0	3496	2168	0	2168	2646	0	2646	1693	0	1693	

LEGEND:

- VLT = Ventilation Load – Total
- VLS = Ventilation Load – Sensible
- VLL = Ventilation Load – Latent
- HRT = Heat Recovery – Total
- HRS = Heat Recovery – Sensible
- HRL = Heat Recovery – Latent
- WVL = Winter Ventilation Load
- WHR = Winter Heat Recovery

WINTER HEATING PERFORMANCE (INDOOR DESIGN CONDITIONS 70°F DB)

Ambient O.D.	VENTILATION RATE					
	450 CFM 77% EFF.		370 CFM 78% EFF.		280 CFM 79% EFF.	
DB/°F	WVL	WHR	WVL	WHR	WVL	WHR
65	2430	1870	2000	1560	1510	1190
60	4860	3740	4000	3120	3020	2390
55	7290	5610	5990	4680	4540	3580
50	9720	7480	8000	6230	6050	4780
45	12150	9360	9990	7790	7560	5970
40	14580	11230	11990	9350	9070	7170
35	17010	19100	13990	10910	10580	8360
30	19440	14970	15980	12470	12100	9560
25	21870	16840	17980	14030	13610	10750
20	24300	18710	19980	15580	15120	11950
15	26730	20580	21980	17140	16630	13140

NOTE: Sensible performance only is shown for winter application.

APPLICATION DATA – WGERV-C5 / WGSERV-C5

SUMMER COOLING PERFORMANCE (INDOOR DESIGN CONDITIONS 75°DB/63°WB)

Ambient O.D.		VENTILATION RATE -- 450 CFM High Speed (Black) 60% EFFICIENCY						VENTILATION RATE -- 370 CFM Low Speed (Red) 62% EFFICIENCY					
DB/ WB	F	VLT	VLS	VLL	HRT	HRS	HRL	VLT	VLS	VLL	HRT	HRS	HRL
105	75	21465	14580	6884	12879	8748	4131	17649	11988	5661	10942	7433	3510
	70	14580	14580	0	8748	8748	0	11988	11988	0	7433	7433	0
	65	14580	14580	0	8748	8748	0	11988	11988	0	7433	7433	0
100	80	31500	12150	19440	18900	7290	11610	25900	9990	15910	16058	6194	9864
	75	21465	12150	9314	12879	7290	5589	17649	9990	7659	10942	6194	4749
	70	12352	12150	202	7411	7290	121	10156	9990	166	6297	6194	103
	65	12150	12150	0	7290	7290	0	9990	9990	0	6194	6194	0
	60	12150	12150	0	7290	7290	0	9990	9990	0	6194	6194	0
95	80	31590	9720	21870	18954	5832	13122	25974	7992	17982	16104	4955	11149
	75	21465	9720	11744	12879	5832	7047	17649	7992	9657	10942	4955	5987
	70	12352	9720	2632	7411	5832	1579	10156	7992	2164	6297	4955	1342
	65	9720	9720	0	5832	5832	0	7992	7992	0	4955	4955	0
	60	9720	9720	0	5832	5832	0	7992	7992	0	4955	4955	0
90	80	31590	7290	24300	18954	4374	14580	25974	5994	19980	16104	3716	12388
	75	21465	7290	14175	12879	4374	8505	17649	5994	11655	10942	3716	7226
	70	12352	7290	5062	7411	4374	3037	10156	5994	4162	6297	3716	2580
	65	7290	7290	0	4374	4374	0	5994	5994	0	3716	3716	0
	60	7290	7290	0	4374	4374	0	5994	5994	0	3716	3716	0
85	80	31590	4860	26730	18954	2916	16038	25974	3996	21978	16104	2478	13626
	75	21465	4860	16605	12879	2916	9963	17649	3996	13653	10942	2478	8465
	70	12352	4860	7492	7411	2916	4495	10156	3996	6160	6297	2478	3819
	65	4860	4860	0	2916	2916	0	3996	3996	0	2478	2478	0
	60	4860	4860	0	2916	2916	0	3996	3996	0	2478	2478	0
80	75	21465	2430	19035	12879	1458	11421	17649	1998	15651	10942	1239	9704
	70	12352	2430	9922	7411	1458	5953	10156	1998	8158	6297	1239	5058
	65	4252	2430	1822	2551	1458	1093	3496	1998	1498	2168	1239	929
	60	2430	2430	0	1458	1458	0	1998	1998	0	1239	1239	0
75	70	12352	0	12352	7411	0	7411	10156	0	10156	6297	0	6297
	65	4252	0	4252	2551	0	2551	3496	0	3496	2168	0	2168

WINTER HEATING PERFORMANCE (INDOOR DESIGN CONDITIONS 70°F DB)

Ambient O.D.	VENTILATION RATE			
	450 CFM 77% EFF.		370 CFM 78% EFF.	
DB/°F	WVL	WHR	WVL	WHR
65	2430	1870	2000	1560
60	4860	3740	4000	3120
55	7290	5610	5990	4680
50	9720	7480	8000	6230
45	12150	9360	9990	7790
40	14580	11230	11990	9350
35	17010	19100	13990	10910
30	19440	14970	15980	12470
25	21870	16840	17980	14030
20	24300	18710	19980	15580
15	26730	20580	21980	17140

LEGEND:

- VLT = Ventilation Load – Total
- VLS = Ventilation Load – Sensible
- VLL = Ventilation Load – Latent
- HRT = Heat Recovery – Total
- HRS = Heat Recovery – Sensible
- HRL = Heat Recovery – Latent
- WVL = Winter Ventilation Load
- WHR = Winter Heat Recovery

NOTE: Sensible performance only is shown for winter application.

BASIC INSTALLATION (Field Installation)

1. Unpack the ventilator assembly, which includes the integral ventilator with attached electrical harness and miscellaneous hardware.

WARNING

Open and lock unit disconnect switch before installing this accessory to prevent injury or death due to electrical shock or contact with moving parts. Turn thermostat to OFF.

Model	For Use With Following Units	Electrical
WGERV-A3	WG24*-A, -B WG30*-A, -B WG36*-A, -B	230/208-1 or 3 phase
WGERV-A5	WG42*-A, -B WG48*-A, -B WG60*-A, -B	230/208-1 or 3 phase
WGSERV-A5	WG3S*-A, -B WG4S*-A, -B WG5S*-A, -B	230/208-1 or 3 phase
WGERV-C3	WG24*-C WG30*-C WG36*-C	460-3 phase
WGERV-C5	WG42*-C WG48*-C WG60*-C	460-3 phase
WGSERV-C5	WG3S*-C WG4S*-C WG5S*-C	460-3 phase

CAUTION

Be sure the correct model and voltage Energy Recovery Ventilator is used with the correct air conditioner or heat pump to insure correct voltage compatibility.

2. Remove intake hood assembly from back of ventilator. (See Figure 1.)
 3. Remove the existing exterior vent option door on the unit. (See Figure 2.)
 4. Remove and save existing unit air filter. Remove and discard the rear exhaust cover plate and remove center screw from condenser grille. (See Figure 3.)
 - 5A. (WGERV-** Models) Install exhaust blower assembly in rear exhaust opening and secure with four (4) screws. Position 4-pin connector so that it is accessible. (See Figure 4A.)
 - 5B. (WGSERV-** Models) Locate ERV fill plate included with this vent package. Locate holes towards the front of the exhaust opening, and install with four (4) screws. Next, install exhaust blower assembly in rear exhaust opening and secure with four (4) screws. Position 4-pin connector so that it is accessible. (See Figure 4B.)
 6. Install ventilator into the unit. (See Figure 5.)
- IMPORTANT NOTE: Position front lip of ventilator over front grille and on top of condenser partition. (See Figure 5.) This is important to insure proper drainage of any water entering damper assembly.*
7. Remove cassette and plug in exhaust blower. Replace cassette. (See Figure 6.)
 8. Open control panel to gain access to unit low voltage terminal block. (Insure all power is OFF prior to opening the control panel.)
 9. Remove female plug of low voltage wiring harness from the heat recovery assembly and snap into filter rack. Route electrical harness leads through the 7/8" bushing into the low voltage box. (See Figure 5.)
 10. Temporarily connect leads C (black), WI (blue), and G (orange) with fork terminal to corresponding points on terminal strip. (See Figures 7 for 230V units and 8 for 460V units and wiring diagram.)
- NOTE: These 24 volt control wires control the starting and stopping of the Energy Recovery Ventilator and can be independently controlled by an energy management control or timer. See separate section on Control Wiring for suggested control schemes.*
11. Remove female plug of high voltage wiring harness from the heat recover assembly and snap into filter rack. Wire to terminal block. (See Figure 7 for WGERV-A* Models, see Figure 8 for WGERV-C* Models, and see Figure 9 for WGSERV-A* & WGSERV-C* Models.)
 12. Plug male plug from female at filter rack. (See Figures 5.)
 13. Close control panel cover.
 14. Replace filter and one (1) screw in condenser grille. (See Figure 3)
 15. Ventilator checkout
 - A. Resupply power to unit.
 - B. Energize the evaporator blower by switching thermostat to the manual fan position with Heat/Cool in OFF position.
 - C. Ventilator heat transfer wheels should rotate slowly (49 RPM). Intake and exhaust blowers should run. (See Figure 10.)
 - D. De-energize the evaporator blower. Energy Recovery wheels, and fresh air and exhaust air blowers should stop.
 - E. This completes ventilator checkout.

16. Disconnect the wires temporarily connected in Step 10 if other control options are to be used.
17. Replace the lower service access panel with the new panel provided. Attach air intake hood with screws provided. (See Figure 10.) Be sure to insert the top flange of the air intake hood into and through the slot in the service door and between the door and insulation to prevent bowing of the door.
18. Close front door.
19. Apply Certification label, included with Installation Instructions, next to unit Serial Plate.
19. Ventilator is now ready for operation.

**FIGURE 1
INTAKE HOOD ASSEMBLY**

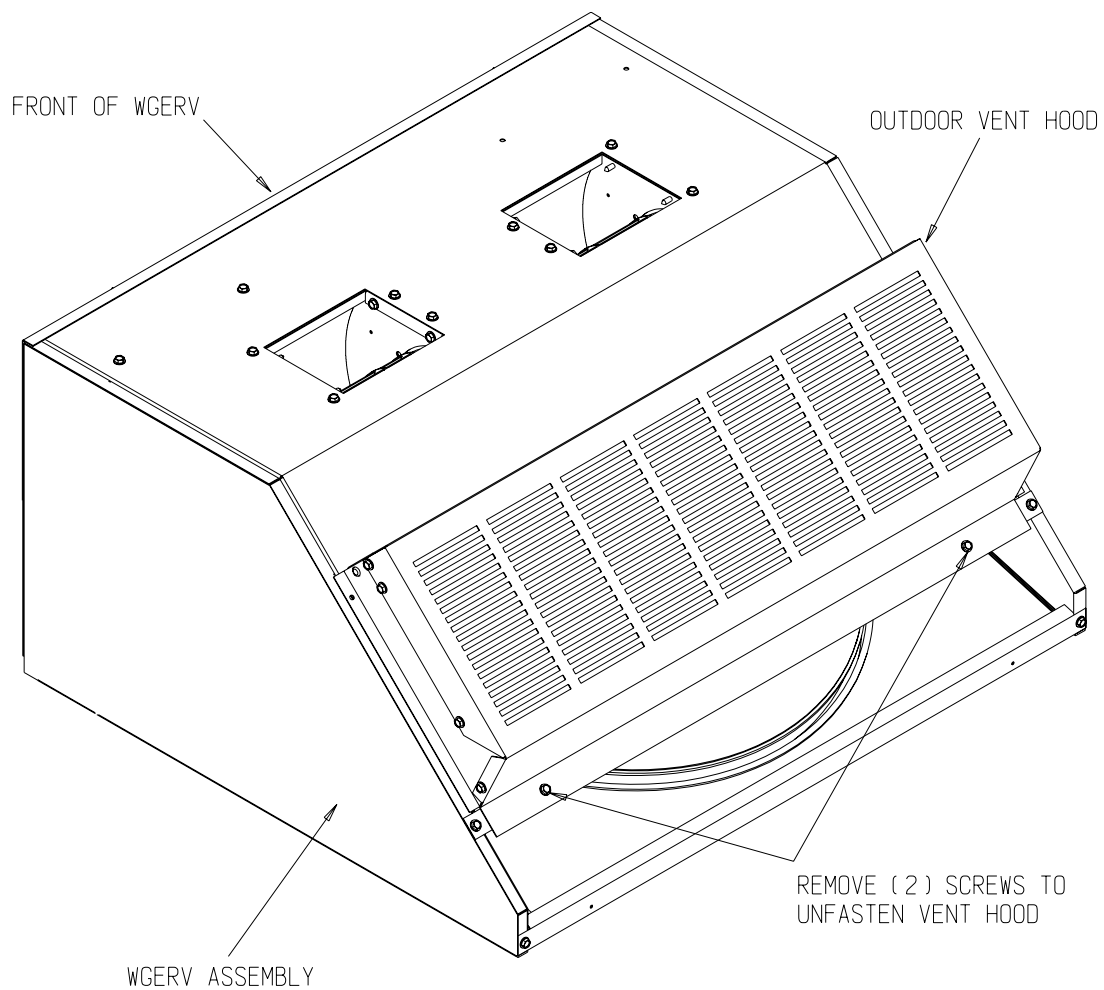

MIS-1504

FIGURE 2
REMOVE VENT OPTION DOOR

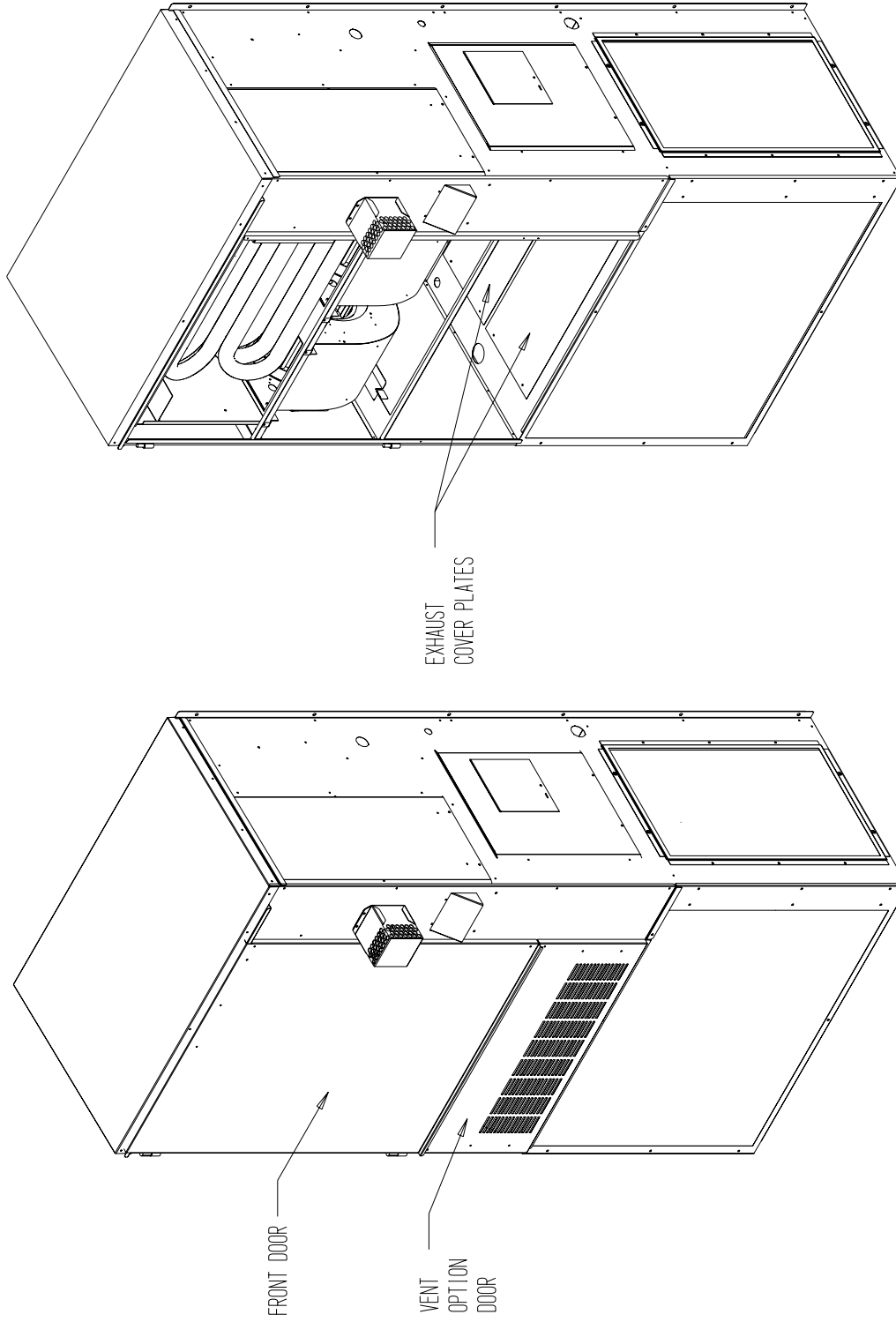
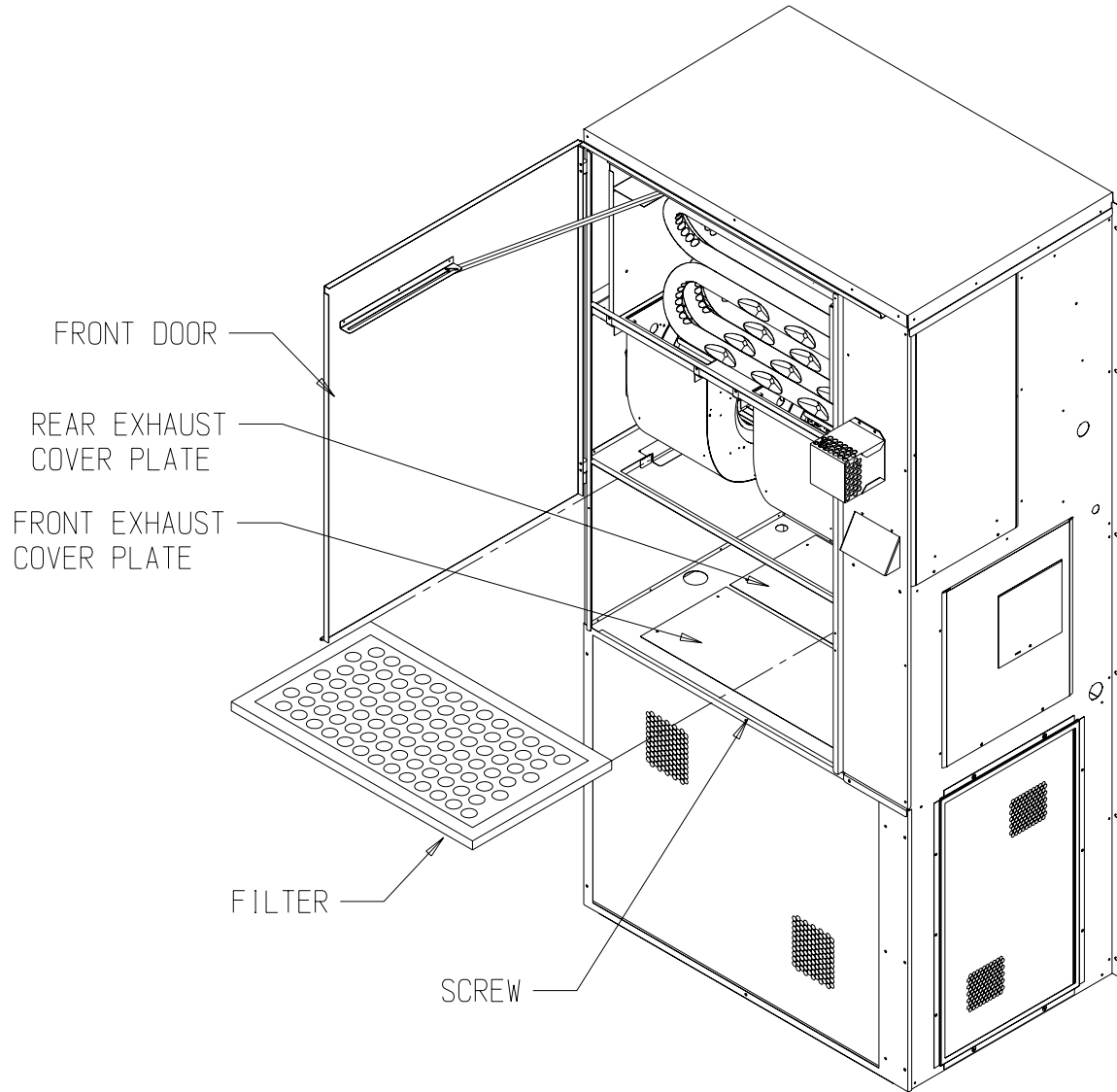
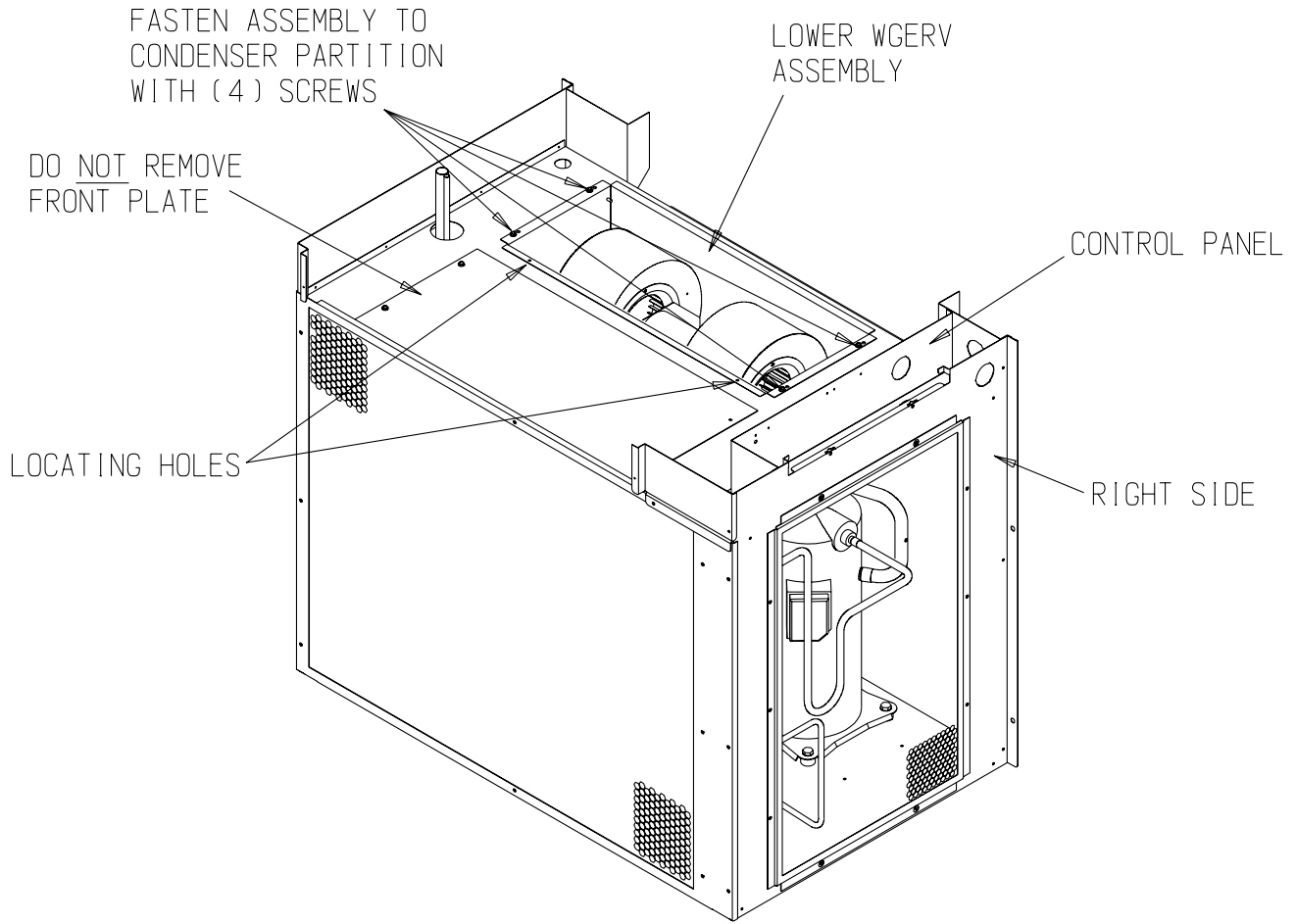

FIGURE 3
FILTER AND EXHAUST PLATE LOCATION



MIS-1449

FIGURE 4A
INSTALLATION OF EXHAUST BLOWER ASSEMBLY
WGERV MODELS



MIS-1500

FIGURE 4B
INSTALLATION OF EXHAUST BLOWER ASSEMBLY
WGSERV MODELS

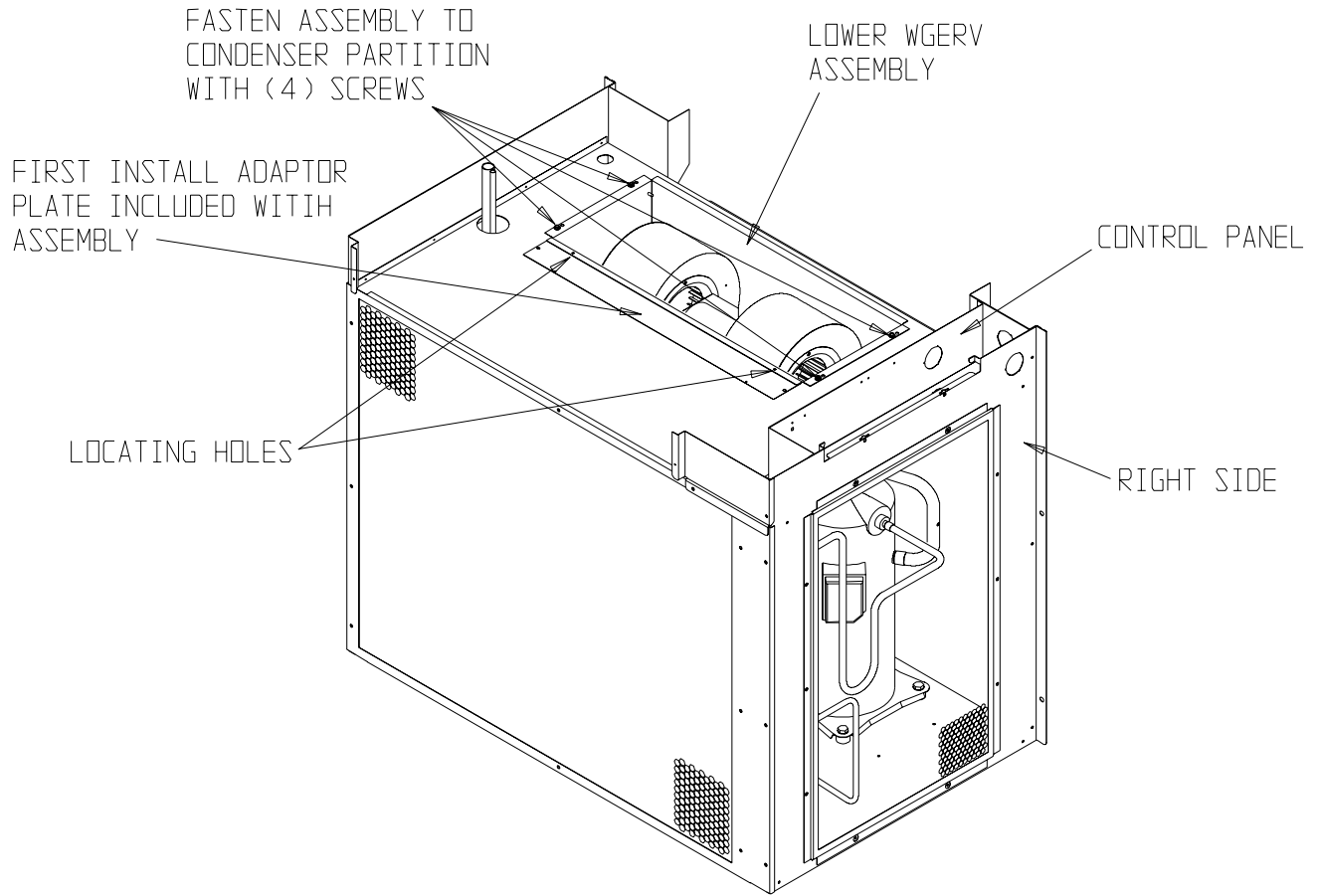

MIS-2426

**FIGURE 5
INSTALLATION OF WGERV**

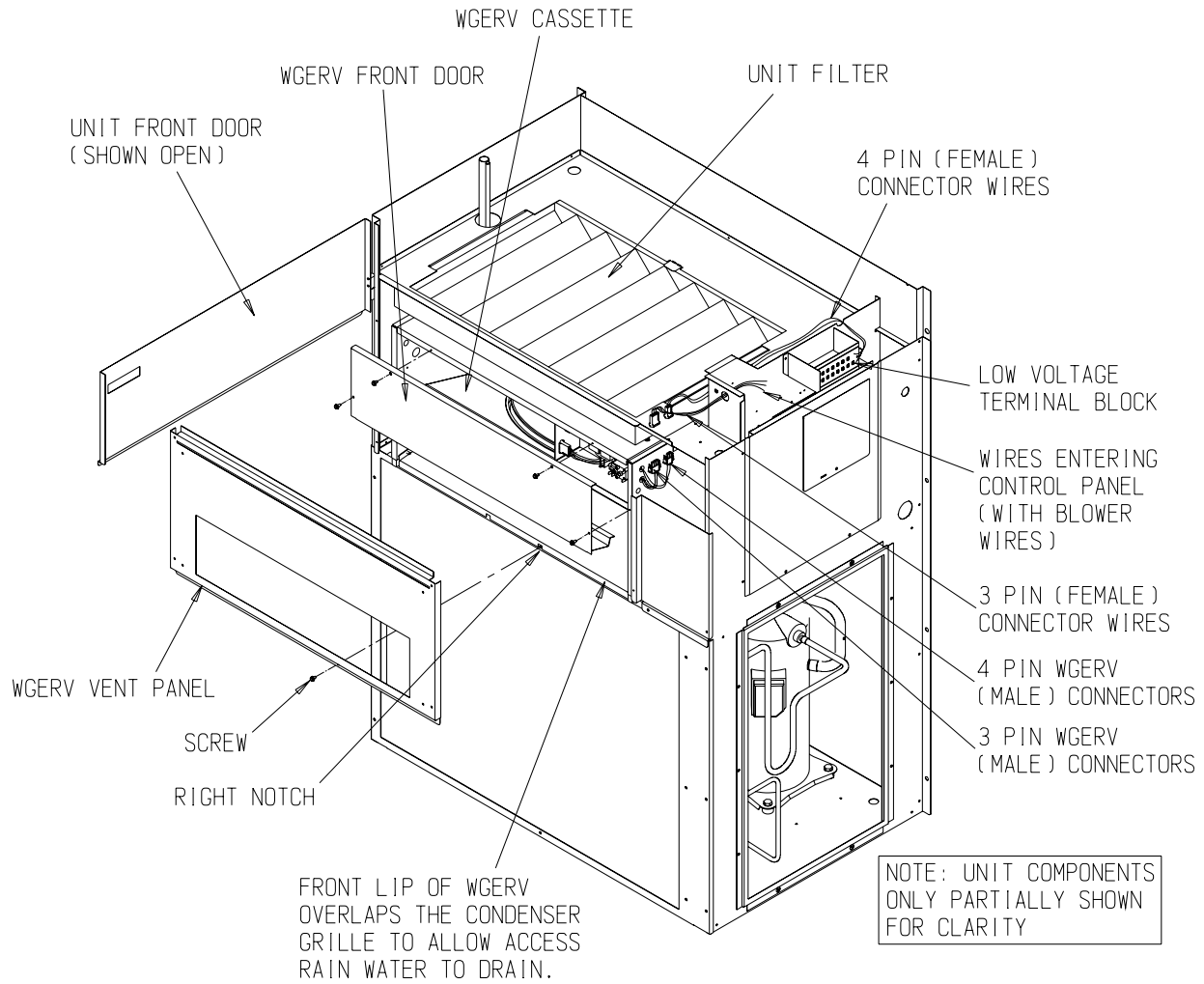

MIS-1501

**FIGURE 6
WGERV ASSEMBLY**

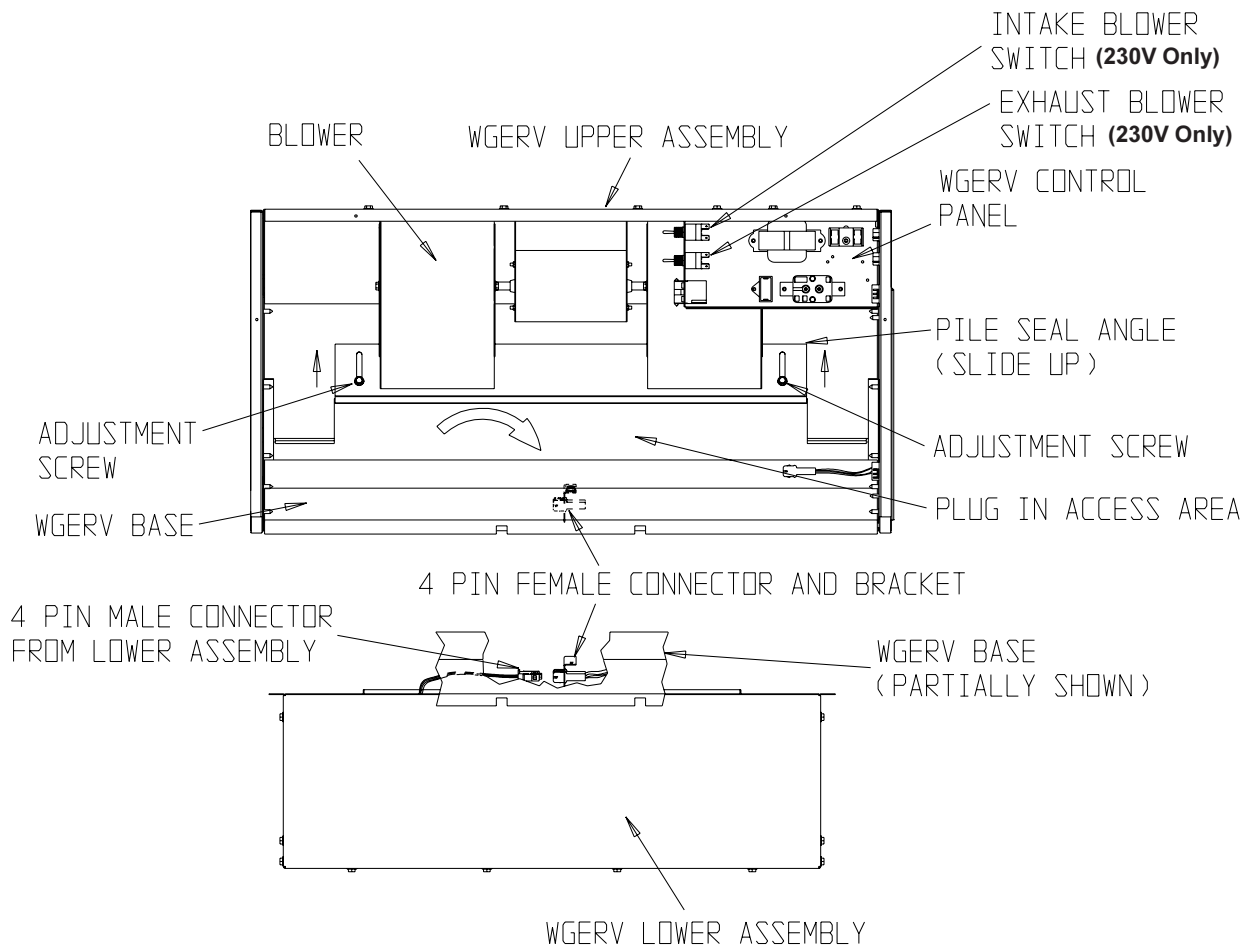

MIS-1502 A

FIGURE 7
WIRING – 230 VOLT
WGERV MODELS

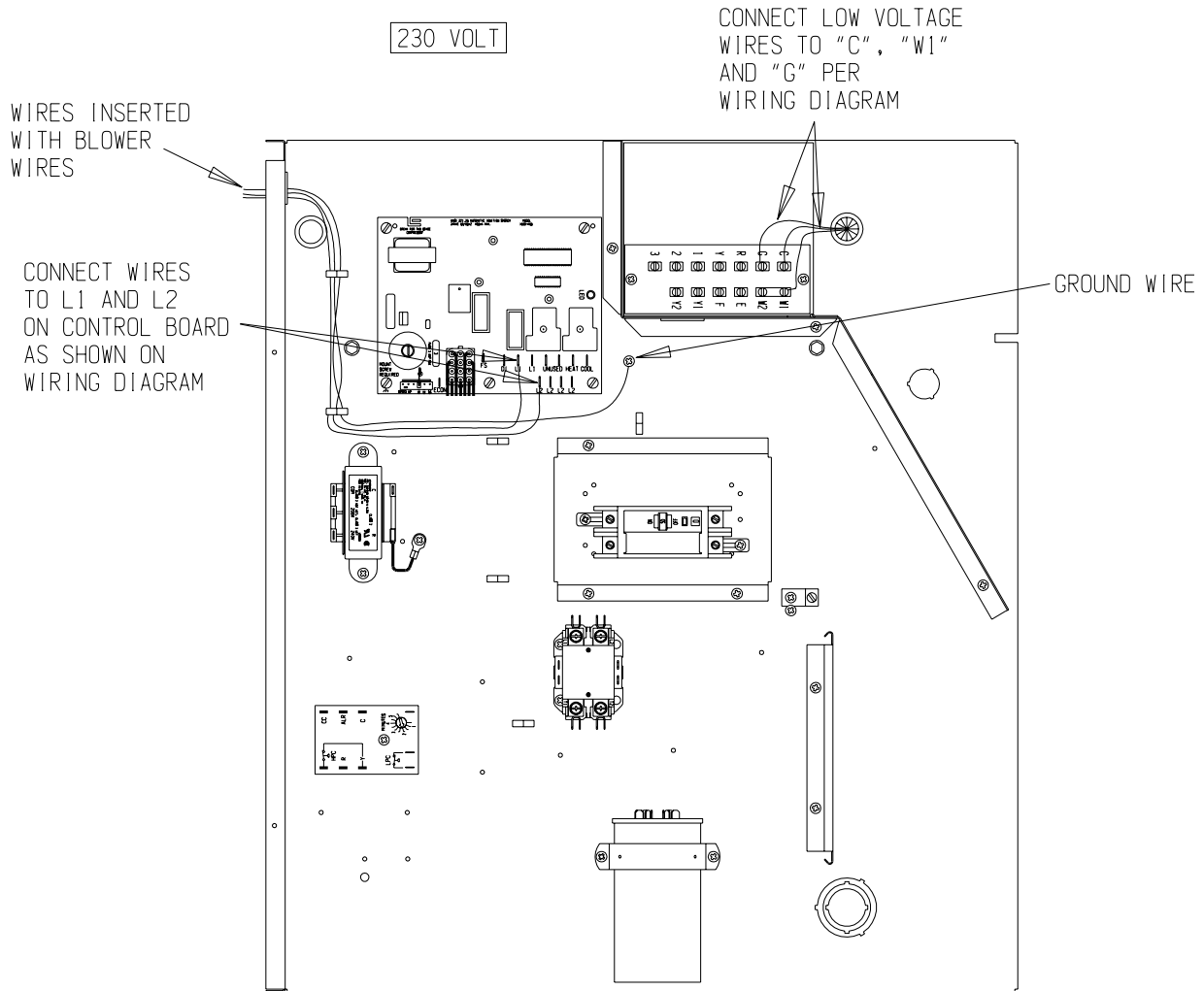

MIS-1511

FIGURE 8
WIRING - 460 VOLT
WGERV MODELS

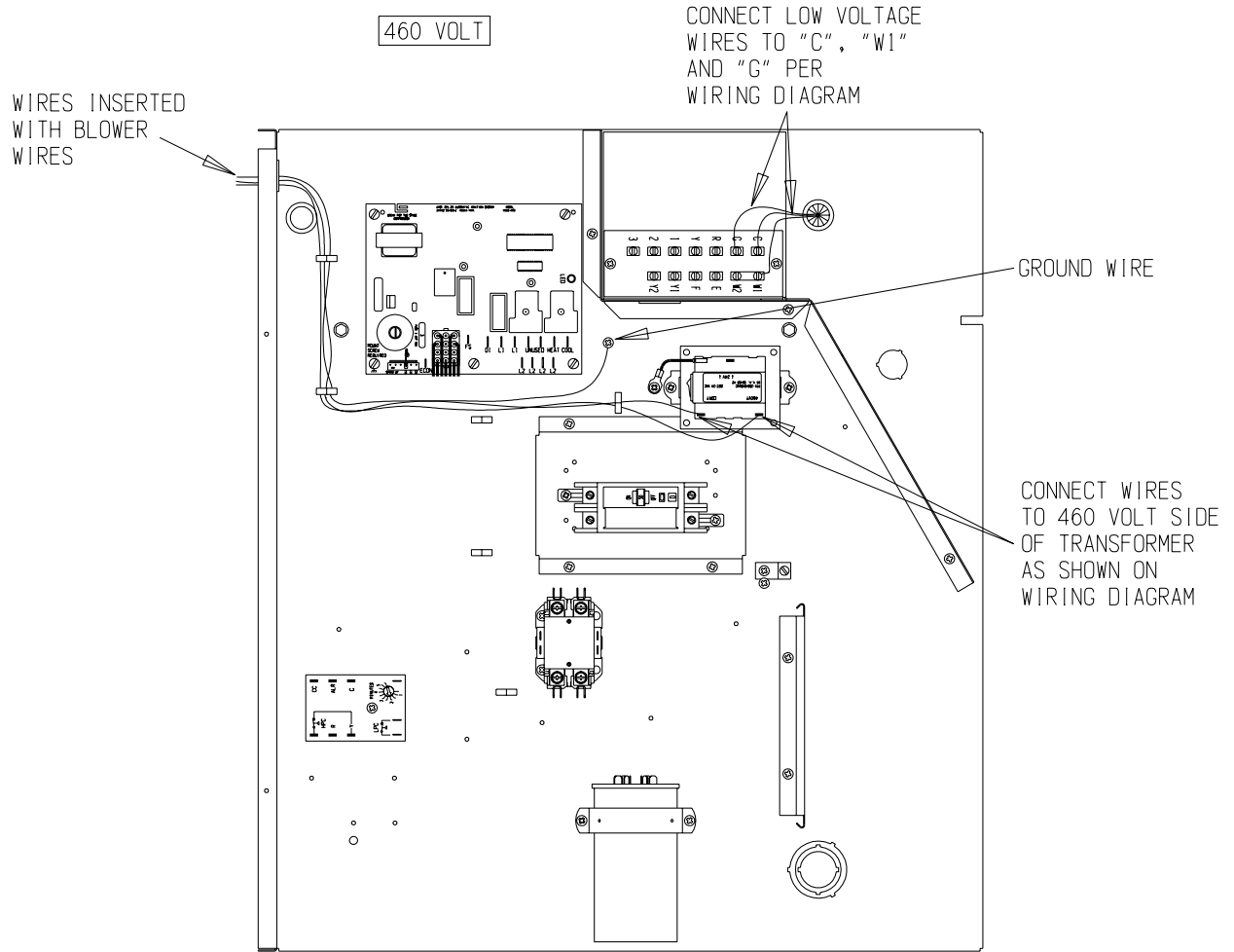

MIS-1506

FIGURE 9
WIRING – ALL WGSERV MODELS

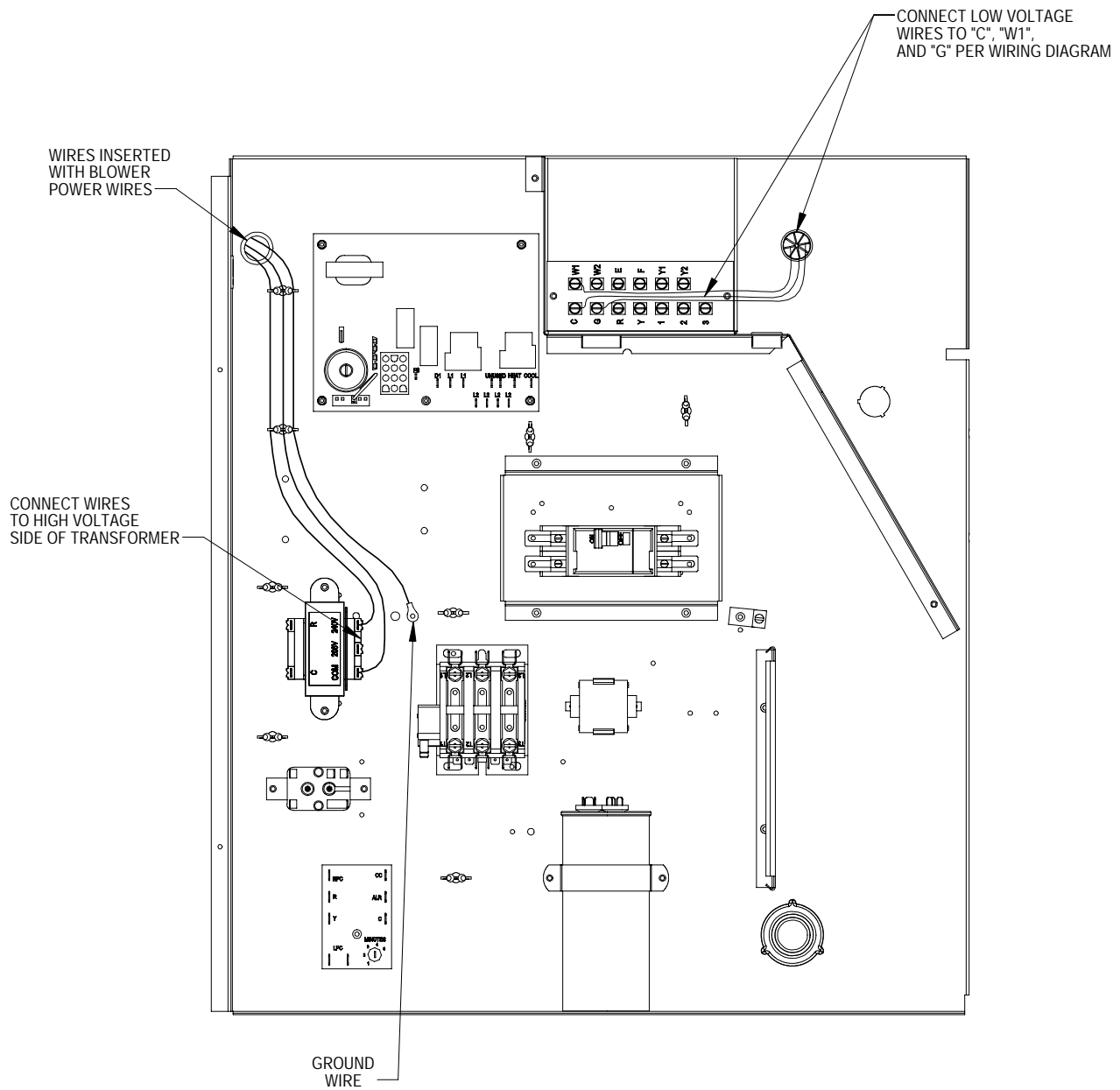

MIS-2427

FIGURE 10
INSTALLATION OF FRESH AIR INTAKE HOOD ASSEMBLY

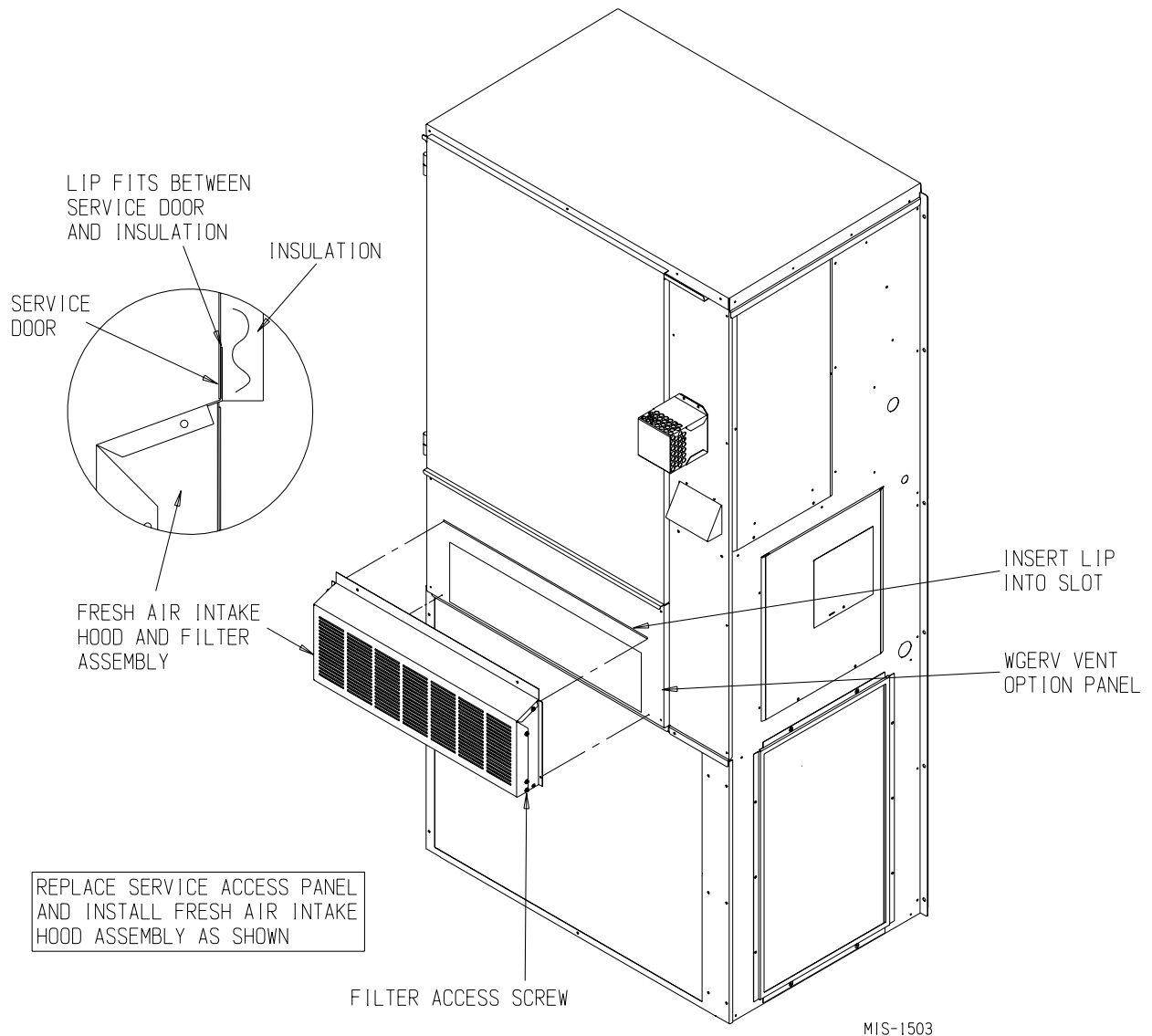
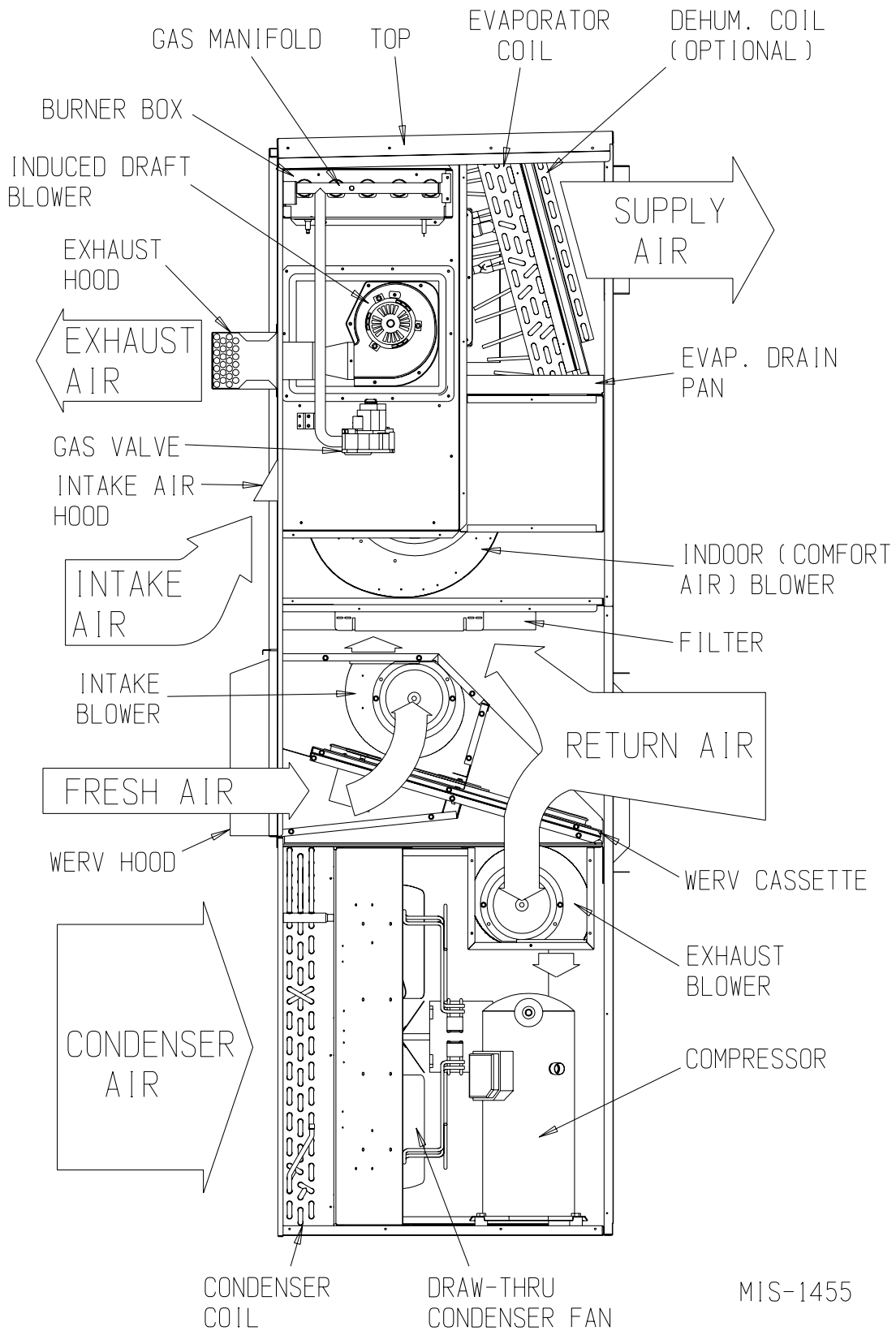

FIGURE 11
OPERATION OF UNIT WITH WGERV INSTALLED



MIS-1455

BASIC INSTALLATION (FACTORY INSTALLED VERSIONS)

1. Remove air intake hood from return air area of unit. (See Figure 1.)
2. Install air intake hood. Refer to Item 17 of Basic Installation (Field Installation).
3. Refer to Control Wiring section for suggested control schemes for the WGERV.
4. After wiring, replace all panels.

CONTROL WIRING

The WGERV comes from the factory with the low voltage control wires wired into the wall mount low voltage terminal strip (see wiring diagrams). Care must be taken when deciding how to control the operation of the ventilator. When designing the control circuit for the ventilator, the following requirements must be met.

CONTROL REQUIREMENTS

1. Indoor blower motor must be run whenever the WGERV is run.
2. Select the correct motor speed tap in the WGERV. Using Table 1 of the WGERV Installation Instructions determine the motor speed needed to get the desired amount of ventilation air needed. For instance, do not use the high speed tap on a WGERV if only 200 CFM of ventilation air is needed. Use the low speed tap. Using the high speed tap would serve no useful purpose and significantly affect the overall efficiency of the air conditioning system. System operating cost would also increase.
3. Run the WGERV only during periods when the conditioned space is occupied. Running the WGERV during unoccupied periods wastes energy, decreases the expected life of the WGERV, and can result in a large moisture buildup in the structure. The WGERV removes 60 to 70% of the moisture in the incoming air, not 100% of it. Running the WGERV when the structure is unoccupied allows moisture to build up in the structure because there is little or no cooling load. Thus, the air conditioner is not running enough to remove the excess moisture being brought in. Use a control system that in some way can control the system based on occupancy.

* * IMPORTANT * *

Operating the WGERV during unoccupied periods can result in a build up of moisture in the structure.

RECOMMENDED CONTROL SEQUENCES

Several possible control scenarios are listed below:

1. Use a programmable electronic thermostat with auxiliary terminal to control the WGERV based on daily programmed occupancy periods. Bard markets and recommends Bard Part #8403-060 programmable electronic thermostat for air conditioner applications. (See Figure 11.)
2. Use a motion sensor in conjunction with a mechanical thermostat to determine occupancy in the structure. Bard markets the CS2000A for this use.
3. Use a DDC control system to control the WGERV based on a room occupancy schedule to control the WGERV.
4. Tie the operation of the WGERV into the light switch. The lights in a room are usually on only when occupied.
5. Use a manual timer that the occupants turn to energize the WGERV for a specific number of hours.
6. Use a programmable mechanical timer to energize the WGERV and indoor blower during occupied periods of the day.

VENTILATION AIRFLOW

The 240 volt WGERV is equipped with a 3-speed motor to provide the capability of adjusting the ventilation rates to the requirements of the specific application by simply changing motor speeds. The 460 volt WGERV is equipped with a 2-speed motor.

**TABLE 1
VENTILATION AIR (CFM)**

Model	High Speed (Black)	Med. Speed (Blue)	Low Speed (Red)
WGERV-A3	450	370	280
WGERV-A5	450	370	280
WGSERV-A5	450	370	280
WGERV-C3	450	N/A	370
WGERV-C5	450	N/A	370
WGSERV-C5	450	N/A	370

All 230 Volt versions are factory set for Medium Speed Intake and Low Speed Exhaust. All 460 Volt versions are wired for High Speed Intake and Low Speed Exhaust.

240-Volt Units (Dual switch models): The speed of each blower (intake and exhaust) can be controlled independently by two (2) switches located on the left side of the control panel, behind the WGERV front door. The switch located on the upper part of the control panel controls the intake blower located in the upper assembly. The switch located on the lower part of the control panel controls the exhaust blower located in the lower assembly. See Figure 6.

460-Volt Units: The speed of each blower (intake and exhaust) can be changed by revising the wiring of each blower. See Figure 12 and Wiring Diagram on 460 Volt models located later in this manual for specific details on wiring of blowers for low speed applications.

If desired, the intake blower can be set up for one speed and the exhaust blower set up for another speed if needed for the specific application.

 WARNING
<p>Open disconnect to shut all power OFF before doing this. Failure to do so could result in injury or death due to electrical shock.</p>

ENERGY RECOVERY VENTILATOR MAINTENANCE

GENERAL INFORMATION

The ability to clean exposed surfaces within air moving systems is an important design consideration for the maintenance of system performance and air quality. The need for periodic cleaning will be a function of operating schedule, climate, and contaminants in the indoor air being exhausted and in the outdoor air being supplied to the building. All components exposed to the airstream, including energy recovery wheels, may require cleaning in most applications.

Rotary counterflow heat exchanges (heat wheels) with laminar airflow are “self-cleaning” with respect to dry particles. Smaller particles pass through; larger particles land on the surface and are blown clear as the flow direction is reversed. For this reason, the primary need for cleaning is to remove films of oil-based aerosols that have condensed on energy transfer surfaces. Buildup of material over time may eventually reduce airflow. Most importantly, in the case of desiccant coated (enthalpy) wheels, such films can close off micron sized pores at the surface of the desiccant material, reducing the efficiency with which the desiccant can absorb and desorb moisture.

FREQUENCY

In a reasonably clean indoor environment such as a school, office building, or home, experience shows that reductions of airflow or loss of sensible (temperature) effectiveness may not occur for ten or more years. However, experience also shows that measurable changes in latent energy (water vapor) transfer can occur in shorter periods of time in commercial, institutional and residential applications experiencing moderate occupant smoking or with cooking facilities. In applications experiencing unusually high levels of occupant smoking, such as smoking lounges, nightclubs, bars and restaurants, washing of energy transfer surfaces, as frequently as every six months, may be necessary to maintain latent transfer efficiency. Similar washing cycles may also be appropriate for industrial applications involving the ventilation of high levels of smoke or oil-based aerosols such as those found in welding or machining operations, for example. In these applications, latent efficiency losses of as much as 40% or more may develop over a period of one to three years.

CLEANABILITY AND PERFORMANCE

In order to maintain energy recovery ventilation systems, energy transfer surfaces must be accessible for washing to remove oils, grease, tars and dirt that can impede performance or generate odors. Washing of the desiccant surfaces is required to remove contaminate buildups that can reduce adsorption of water molecules. The continued ability of an enthalpy wheel to transfer latent energy depends upon the permanence of the bond between the desiccant and the energy transfer surfaces.

Bard wheels feature silica gel desiccant permanently bonded to the heat exchange surface without adhesives; the desiccant will not be lost in the washing process. Proper cleaning of the Bard energy recovery wheel will restore latent effectiveness to near original performance.

MAINTENANCE PROCEDURES

NOTE: Local conditions can vary and affect the required time between routine maintenance procedures, therefore all sites (or specific units at a site) may not have the same schedule to maintain acceptable performance. The following timetables are recommended and can be altered based on local experience.

QUARTERLY MAINTENANCE

1. Inspect mist eliminator/prefilter and clean if necessary. This filter is located in the fresh air intake hood on the front of the unit. This is an aluminum mesh filter and can be cleaned with water and any detergent not harmful to aluminum.
2. Inspect wall mount unit filter and clean or replace as necessary. This filter is located either in the unit, in a return air filter grille assembly, or both. If in the unit it can be accessed by removing the lower service door on the front of the unit. If in a return air filter grille, by hinging the grille open to gain access.
3. Inspect energy recovery ventilator for proper wheel rotation and dirt buildup. This can be done in conjunction with Item 2 above. Energize the energy recovery ventilator after inspecting the filter and observe for proper rotation and/or dirt buildup.
4. Recommended energy recovery wheel cleaning procedures follow: Disconnect all power to unit. Remove the lower service door of the wall mount unit to gain access to the energy recovery ventilator.
5. Remove the front access panel on the ventilator. Unplug amp connectors to cassette motors. Slide energy recovery cassette out of ventilator.
6. Use a shop vacuum with brush attachment to clean both sides of the energy recovery wheels.
7. Reverse shop vacuum to use as a blower and blow out any residual dry debris from the wheel.

NOTE: Discoloration and staining of the wheel does not affect its performance. Only excessive buildup of foreign material needs to be removed.

8. If any belt chirping or squealing noise is present, apply a small amount of LPS-1 or equivalent dry film lubricant to the belt.

ANNUAL MAINTENANCE

1. Inspect and conduct the same procedures as outlined under Quarterly Maintenance.
2. To maintain peak latent (moisture) removal capacity, it is recommended that the energy recovery wheels be sprayed with a diluted nonacid based evaporator coil cleaner or alkaline detergent solution such as 409.

NOTE: Do not use acid based cleaners, aromatic solvents, temperatures in excess of 170°F or steam. Damage to the wheel may result.

Do not disassemble and immerse the entire heat wheel in a soaking solution, as bearing and other damage may result.

3. Rinse wheel thoroughly after application of the cleaning solution, and allow to drain before reinstalling.
4. No re-lubrication is required to heat wheel bearings of the drive motor, or to the intake and exhaust blower motors.
5. If any belt chirping or squealing noise is present, apply a small amount of LPS-1 or equivalent dry film lubricant to the belt.

**FIGURE 12
TERMINAL BLOCK LOCATION
460 VOLT MODELS**

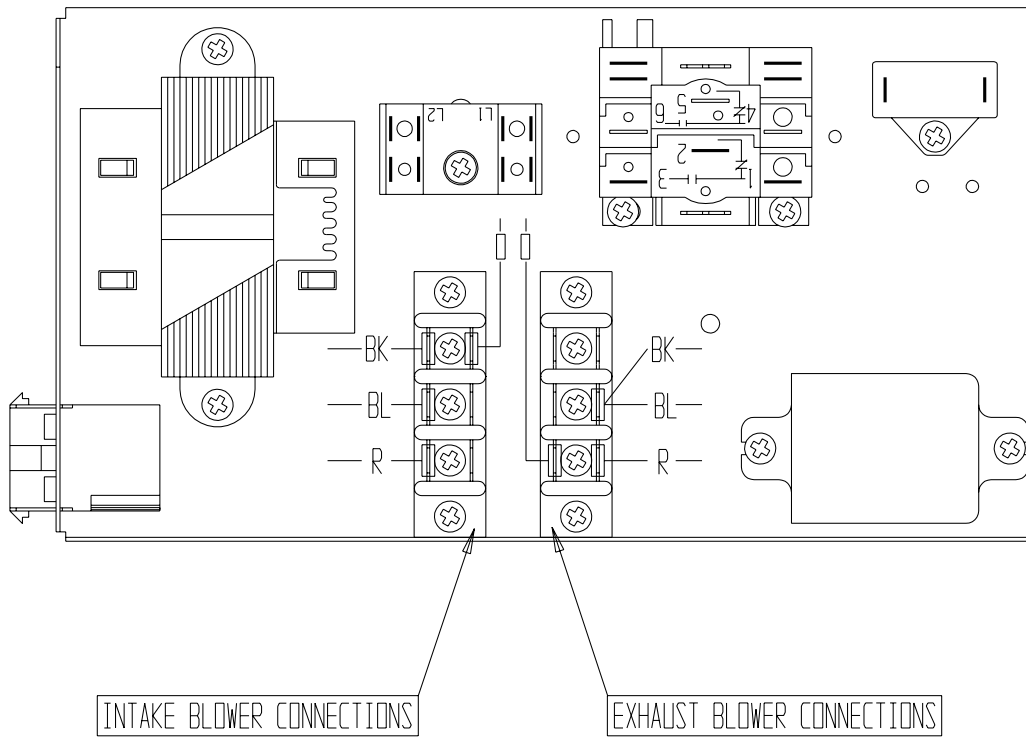

INTAKE BLOWER MOTOR CONNECTIONS ARE FACTORY WIRED ON HIGH SPEED WHILE EXHAUST BLOWER MOTOR CONNECTION ARE WIRED ON LOW SPEED. THIS IS DONE TO MAINTAIN POSITIVE BUILDING PRESSURIZATION PER ASHRAE 62 STANDARD. TO CHANGE ERV BLOWER SPEEDS, SEE CHART BELOW, OR WIRING DIAGRAM 4056-184 INCLUDED IN THIS MANUAL.

HIGH SPEED

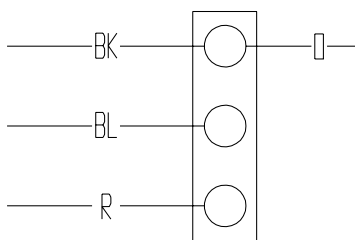

LOW SPEED

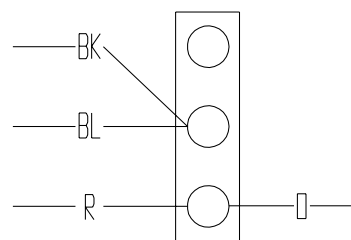

MIS-2071 B

FIGURE 13
HUB ASSEMBLY WITH BALL BEARING

