



BARD MANUFACTURING COMPANY
Bryan, Ohio 43506

Since 1914...Moving ahead, just as planned.

Manual: 2100-366A
Supersedes: 2100-366
File: Vol I, Tab 20
Date: 07-10-00

USER'S INFORMATION MANUAL

WG-Series Combination Gas/Electric Wall-Mount™

We're pleased you've chosen our air conditioner/gas furnace to supply your cooling/heating needs. Please keep this manual in a safe, yet readily available place. It contains important and useful information.

ATTENTION, INSTALLER: After installing air conditioner/gas furnace, give the user:

- User's Information Manual
- Parts List
- Installation Instructions
- Warranty Information

ATTENTION, USER! Your installer should give you the above four important documents relating to your air conditioner/gas furnace. Keep these as long as you do your equipment. Pass these documents on to later purchasers or furnace users. If any of the four documents are missing or damaged, contact your installer or manufacturer for replacement. For efficient service, please give your unit model and serial number, from Section 1 or from your serial rating plate.

WARNING

If the information in this manual is not followed exactly, a fire or explosion may result causing property damage, personal injury or loss of life

- Do not store or use gasoline or other flammable vapors and liquids in the vicinity of this or any other appliance.
- **WHAT TO DO IF YOU SMELL GAS**
 - Do not try to light any appliance.
 - Do not touch any electrical switch; do not use any phone in your building.
 - Immediately call your gas supplier from a neighbor's phone. Follow the gas supplier's instructions.
 - If you cannot reach your gas supplier, call the fire department.
- Installation and service must be performed by a qualified installer or the gas supplier.

WARNING

Read and follow all safety information in this manual, operating instructions and furnace safety labels. Failure to follow safety precautions could result in damage, injury or death.

IMPORTANT SAFETY NOTE: You must know how to turn off gas and electricity to air conditioner/gas furnace. Your qualified installer, service agency or gas supplier can teach you to use controls and switches.

WARNING

Do not use this air conditioner/gas furnace if any part has been under water. Immediately call a qualified service technician to inspect the unit and to replace any part of the control system and any gas control which has been underwater.

Thank you for reading these safety statements. Please read on so you will know how to maintain your air conditioner/gas furnace for years of dependable service.

CONTENTS

Section 1		Figures		
Rating Plate Information	1	Figure 1	Typical Gas Piping	6
Section 2		Figure 2	Step-by-Step Instructions on Lighting Burners	9
Important Safety Precautions	1	Figure 3	Filter Locations	11
Section 3		Figure 4	Location of Access Panels	11
Understanding How Your Furnace and Air Conditioner Works	3	Figure 5	Start Up Procedures	12
Section 4				
Turning Off Furnace in an Emergency	4			
Section 5				
Operating Your Furnace	8			
Section 6				
Proper Maintenance of Your Furnace and Air Conditioner	8			
Section 7				
Air Conditioning Start Up Procedure Crankcase Heater	12			
Section 8				
Ventilation Options	12			
Section 9				
Replacement Parts	13			
Section 10				
Outdoor Coil	13			

Manufactured under the following U.S Patent Numbers:
5,485,878; 5,022,116; 4,924,934; 4,875,520;
4,825,936; 4,432,409

**COPYRIGHT JULY 2000
BARD MANUFACTURING COMPANY
BRYAN, OHIO USA 43506**

SECTION 1 • RATING PLATE INFORMATION

Record the manufacturer's name, unit model number and serial number below. These are your furnace rating plate. Record installation date which is important for warranty purposes.

YOUR FURNACE INFORMATION

Furnace Type _____

Manufacturer's Name _____

Model Number _____

Serial Number _____

Date Installed _____

Installer/Service _____

Address _____

City/State/Zip Code _____

Telephone Number _____

SECTION 2 • IMPORTANT SAFETY PRECAUTIONS

2.A HAZARD ALERT SYMBOL



An explanation point surrounded by a triangle.

2.B SIGNAL WORDS

Years of safe, dependable service are assured when you understand and follow all safety precautions.

Signal words **“WARNING”** and **“CAUTION”** alert you to potential hazards.

“WARNING” indicates a potentially hazardous situation which, if not avoided, could result in death or serious injury.

“CAUTION” indicates a potentially hazardous situation which, if not avoided, may result in minor or moderate injury. It may also be used to alert against unsafe practices. It can also be used to signal property damage only potential.

2.C. SAFETY PRECAUTIONS

These are some of our most important safety precautions; others are throughout this manual. Please read and follow them.

2.1 GAS AND COMBUSTION PRODUCTS



Any condition that will allow gas of combustion products to enter furnace area can cause nausea, asphyxiation or fire resulting in damage, injury or death.

Natural gas and propane (LP) gas have characteristic odors. When your furnace is operating correctly, you should not smell any unfamiliar odor. Normally, burning gas with air produces combustion products which contain carbon dioxide, oxygen and water vapor. Under abnormal conditions, combustion products can contain aldehydes and carbon monoxide.

- Aldehydes have a strong pungent, acrid smell that can cause nausea.
- Carbon monoxide is tasteless, colorless and odorless. It can cause headaches, flu-like symptoms or nausea. We refer to all these symptoms as nausea in this manual. It can also cause death by asphyxiation.

WARNING

Any unfamiliar smell can alert you to presence of gas or aldehydes. If you detect any unfamiliar odor follow instruction in Section 4.B.1. Otherwise, nausea, asphyxiation or fire could occur resulting in damage, injury or death.

WARNING

Do not block or cover combustion openings in the furnace. Blocking or covering these openings could cause nausea, asphyxiation or fire resulting in damage, injury or death.

WARNING

A loud noise may mean faulty burner ignition. If your furnace makes a loud noise, turn it off. Follow instructions in Section 4.B.2. If you don't turn off your furnace, it could cause fire or an explosion resulting in damage, injury or death.

WARNING

Do not operate furnace with blower door open or removed. Do not alter furnace to allow operation with blower door removed. Doing either should allow combustion products to circulate throughout the furnace area causing nausea, asphyxiation or fire resulting in damage, injury or death.

WARNING

Front door must be in place during furnace operation. Hot surfaces behind front door.

2.2 STORAGE AND USE OF FLAMMABLE, CORROSIVE AND COMBUSTIBLE PRODUCTS NEAR YOUR FURNACE

WARNING

Never store or use flammable liquids or vapors near or on your furnace. These include gasoline, kerosene, cigarette lighter fluid, cleaning fluids, solvents, paint thinners or painting compounds. Flammable vapors can travel great distances before igniting.

WARNING

Never store or use anything near or on your furnace that can produce vapors that are corrosive to gas-fired furnaces. Vapors from products containing chlorines, fluorines, bromines and iodines can cause vent system or heat exchanger failure. Examples of such products are spray or aerosol containers, detergents, bleaches, cat litter, waxes, adhesives, solvents and other cleaning compounds. Vent system or heat exchanger failure could cause nausea, asphyxiation or fire resulting in damage, injury or death.

WARNING

Never store anything combustible near or on your unit. A fire could occur resulting in damage, injury or death.

2.3 ALTERATION OF FURNACE CONTROLS

WARNING

Do not alter any gas or electrical controls (gas control or safety controls) in any manner. Altering them could cause furnace to operate unsafely resulting in damage, injury or death.

SECTION 3 • UNDERSTANDING HOW YOUR FURNACE WORKS

Your installer should have given you a detailed explanation of how the furnace operates. Shown below are the basic operation characteristics and sequence of operation. If you have any questions consult your installer and/or service agency.

*** * IMPORTANT * ***

There are many types of thermostats compatible with this furnace. Make sure you understand the specific type installed. Ask installer for detailed explanation, and retain thermostat instruction manual for reference.

This furnace is equipped with a vent shut-off system which monitors the combustion air into the burners by means of a pressure sensing device. When the vent becomes blocked, this device turns off the gas valve circuit to prevent flue products from entering the structure. In the event that this occurs, shut off furnace and contact a qualified service agency.

3.1 BASIC OPERATION – HEATING CYCLE

This furnace is operated by an Integrated Furnace Control (IFC) and a gas control system which controls all functions of the furnace.

On a call for heat from the thermostat, the IFC first turns on the inducer motor. The pressure switch then closes signaling the ignition control to proceed with ignition function.

The ignition system consists of a direct spark igniter (DSI) and remote sensor. When the thermostat calls for heat the DSI sparks to light main burner gas. Once ignited the remote sensor confirms flame carryover to all burners.

There is a 60 second delay after main burner is on until the comfort air blower starts on heating speed. After the thermostat is satisfied, the burners will go off as gas valve closes. The inducer will continue to run for 30 seconds, and the comfort air blower will continue to run for 2-1/2 minutes.

3.2 BASIC OPERATION – COOLING CYCLE

On a call for cool the compressor and condenser fan will start immediately, and the comfort air blower will start 7 seconds later on cooling speed. Note: Some models may be equipped with optional Low Ambient Control that will cycle the condenser fan motor to maintain proper refrigerant pressures under lower outdoor temperature conditions. When the thermostat is satisfied the compressor and condenser fan will stop and the comfort air blower will continue to operate for 60 seconds.

3.2.1 COMPRESSOR CONTROL MODULE (CCM)

All models are equipped with a compressor control module. This control is an anti-short cycle/lockout timer with high and low pressure switch monitoring and alarm relay output.

Delay on Make Timer and Break Time Delay

- On initial power up, or any time the power is interrupted to the unit, the delay on make period begins. This delay will be 2 minutes plus 10% of the delay on break setting. This feature assures that pressures will be equalized for normal start up if there are brief power interruptions, and can accommodate staggered starts for dual unit installations as long as the off delay periods are set differently for the two units.
- During routine operation of the unit with no power interruptions the compressor will operate on demand with no delay as long as off delay time has been met.
- Adjustable 30 second to 5 minute delay on break timer assures that pressures can equalize if units are short cycled by the operating controls or personnel. Recommended settings would be 2 minutes for unit 1 and 3 minutes for Unit 2.

High Pressure Switch and Lockout Sequence

- If the high pressure switch opens, the compressor contactor will de-energize immediately. The lockout time in the CCM will go into a soft lockout and stay locked out until the high pressure switch closes and the delay on break has expired.
- If the high pressure switch opens again during the same operating cycle the CCM will go into a manual lockout condition.
- Recycling the wall thermostat resets the manual lockout.

Low Pressure Switch, Bypass and Lockout Sequence (Optional)

- If the low pressure switch opens for more than 120 seconds the compressor contactor will de-energize and the CCM will go into soft lockout.
- Regardless of the state of the low pressure switch the compressor contactor will reenergize after the delay on break time has expired.
- If the low pressure switch remains open, or opens again for longer than 120 seconds, the CCM will go into a manual lockout and the alarm relay circuit will energize.
- Recycling the wall thermostat resets the manual lockout.

NOTE: Both high and low pressure switch controls are inherently automatic reset devices. The high pressure switch opens at 425 and closes at 325 psig, and the low pressure switch opens at 14 and closes at 30 psig. The lockout features, both soft and manual, are a function of the Compressor Control Module.

Alarm Relay Output

- Alarm terminal on Compressor Control Module is 24V AC output connection for applications where signal is desired. This terminal is powered whenever compressor is in manual lockout due to high pressure or low pressure sequences as described.

PHASE MONITOR

All units with three phase scroll compressors are equipped with a three phase line monitor to prevent compressor damage due to phase reversal.

The phase monitor in this unit is equipped with two LEDs. If the “&” signal is present at the phase monitor and phases are correct, the green LED will light.

If phases are reversed, the red fault LED will be lit and compressor operation is inhibited.

3.3 MANUAL FAN (CONTINUOUS AIRFLOW) OPERATION

If wall thermostat is set to MANUAL (ON) position to operate comfort air blower continuously to provide air circulation throughout the building, the blower will operate on the heating speed rather than the cooling as is typical with most systems. This permits the air to circulate as desired but helps keep the operating noise level down as well a conserving energy.

During a call for cooling, the blower automatically shifts up to cooling speed, and remains there until 60 seconds after thermostat is satisfied then drops back to heating speed.

SECTION 4 • TURNING OFF FURNACE IN AN EMERGENCY

WARNING

Have a qualified installer, service agency or gas supplier teach you location and operation of gas and electrical shut-off devices. Ask them any questions you have about this section. If you don't turn off your furnace in an emergency damage, injury or death could result.

In an emergency you *must* know how to turn off gas and electricity. Find out how *before* the emergency.

 WARNING
Should overheating occur or the gas supply fail to shut off, shut off the manual gas valve to the furnace before shutting off the electrical supply. Failure to do so can cause a fire or explosion which could result in damage, injury or death.

4.A GAS AND ELECTRICAL SHUT-OFF DEVICES

1. GAS SHUT-OFF DEVICES

In an emergency, you may not be able to reach all the gas shut-off devices. You must know how to turn off gas using any one of the three manual types:

- a. Manual Shut-off Switch on Gas Control
Gas control location is behind the access panel on the right side. See Lighting and Shutdown Instructions in Section 5 for more information.

To turn gas control furnace knob OFF, turn it to “OFF” position. Use this same procedure when you leave a vacation home vacant and do not want the furnace to operate.

- b. Manual In-Line Shut-off Valve in Gas Supply Line.

This valve could be next to furnace. Figure 1 shows a typical installation.

Normally, gas is ON when you turn the shut-off valve handle parallel to gas pipe. Gas is OFF when you turn handle 90° from gas pipe.

- c. Manual Shut-off Valve at Natural Gas Meter or Propane (LP) Gas Tank.

Normally, natural gas is ON when you turn shut-off parallel to gas pipe. Gas is OFF when you turn shut-off 90° from gas pipe. Some valves require a wrench or other tools.

2. ELECTRICAL SHUT-OFF DEVICES

In an emergency, you may not be able to reach both of your electrical shut-off devices. Therefore, you must know how to turn off electricity using either one of them. Here are two types of electrical shut-off devices:

- a. There should be an electrical shut-off device located on or immediately adjacent to the furnace.
- b. There should be a separate circuit breaker or fuse serving only the furnace located in the main circuit breaker or fuse panel. Know its location and make sure this device is clearly identified.

FIGURE 1
TYPICAL GAS PIPING

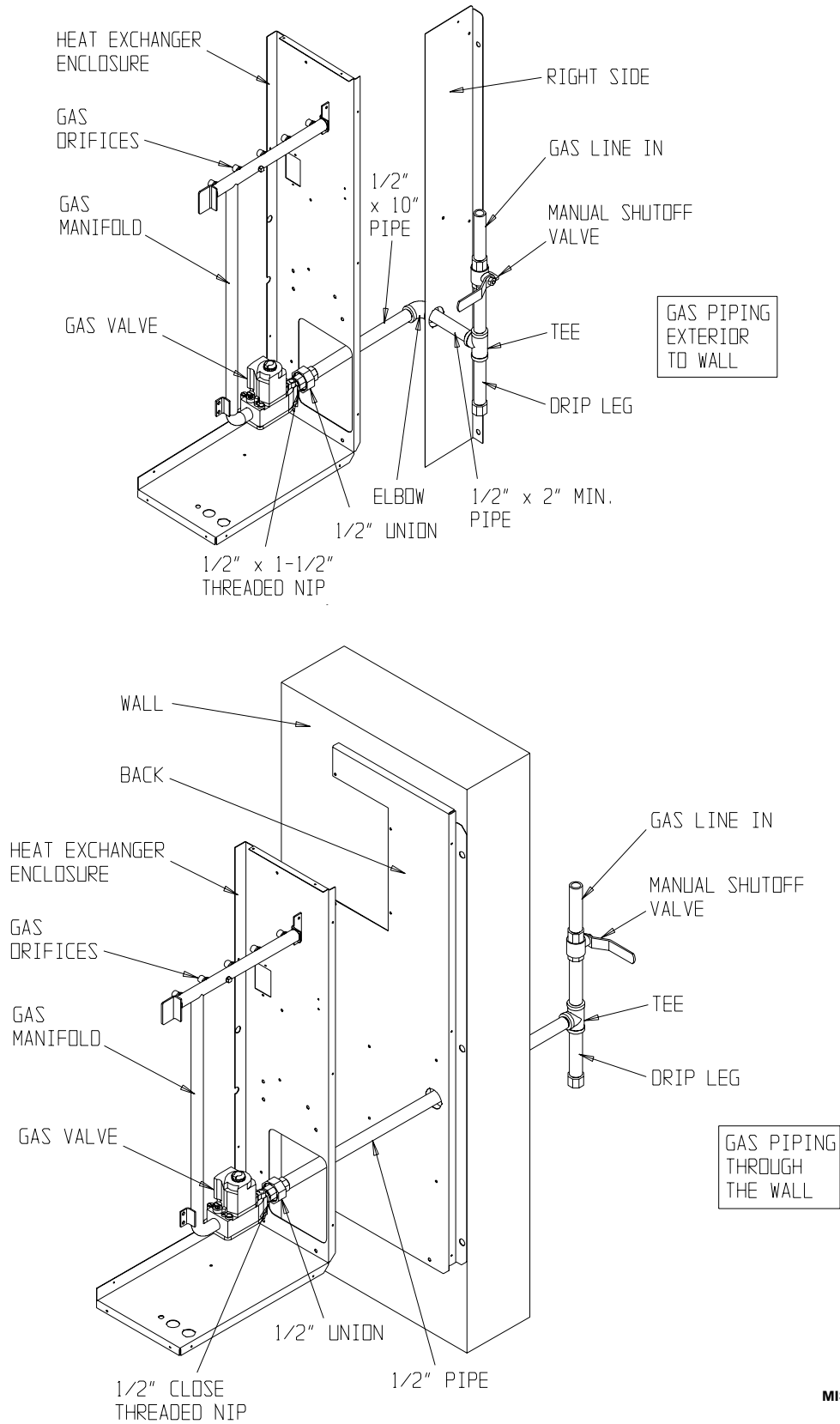

MIS-1478

4.B POSSIBLE EMERGENCIES AND RECOMMENDED ACTIONS

WARNING

If gas or electricity is off due to an emergency, only a qualified installer, service agency or gas supplier should turn it back on. Doing it yourself could result in damage, injury or death.

1. **Possible Emergency:** Smelling gas or other unfamiliar smell; or not knowing what may be wrong or that to do about it.

ACTION: For your safety –

- a. Leave your house or building immediately.
- b. Go to a neighbor's or another building.
- c. Use their telephone.
- d. Call your gas supplier. Tell them you smell gas and give them your name and address.
- e. If you cannot reach gas supplier, call fire department.

WARNING

Three important **things not to do** –

1. Don't try to light any gas appliances.
2. Don't touch any electrical switches
3. Don't use the telephone in your house or building.

Any of the above may cause a spark which could cause a fire or explosion resulting in damage, personal injury or death.

2. **Possible Emergency:** Your thermostat is set below room temperature; yet even though the blower is on, the air coming from your room registers continually gets hotter.

ACTION:

- a. Turn room thermostat to its lowest or OFF setting.

- b. If you can do so safely, turn gas off. Use manual shut-off valve at gas meter or on propane (LP) gas tank. You may need a wrench or tools. If you can safely turn off electricity at the main circuit panel, do so. If you cannot do these things safely, leave your home or building immediately. Call your gas supplier or fire department from a neighbor's phone for help.

3. **Possible Emergency:** Your thermostat is set above room temperature. The blower is on but the air coming from your room registers is hot, then cold, then hot, then cold in a continuing cycle. This condition indicates lack of airflow through furnace.

ACTION:

- a. Make sure air filter is clean and installed correctly.
- b. Check that registers and return air grilles are open and unobstructed.
- c. If condition continues, call your local qualified service technician or gas supplier.

4. **Possible Emergency:** While furnace is operating, you smell unfamiliar odors that go away when furnace is off.

WARNING

Unfamiliar odors may mean gas or aldehydes are present which could result in damage, injury or death.

ACTION:

- a. Turn thermostat to its lowest or OFF setting.
- b. Move gas valve control level to OFF.
- c. If blower is not operating, immediately turn off electricity to furnace using shut-off device near furnace or at main circuit panel.
- d. If blower is operating, wait five minutes for furnace to cool down and then turn off electricity to furnace using shut-off device near furnace or at main circuit panel.
- e. Call your local qualified service technician or gas supplier.

5. **Possible Emergency:** Main electrical circuit breaker for furnace cannot be reset without tripping again or new fuses continue to blow.

ACTION:

- a. Move gas valve control level to OFF.
- b. Call your local qualified service technician or gas supplier.

SECTION 5 • OPERATING YOUR FURNACE

After reading the Safety Information and Precautions follow Operating Instructions on front door of furnace and instructions repeated on Page 8.

 WARNING
If you do not follow these instructions exactly a fire or explosion could occur resulting in damage, injury or death.

 WARNING
Never use tools to move gas control knob. Only use your hand. If gas control knob will not move by hand, do not force it or try to repair it. Call a qualified installer, service agency or gas supplier. Forcing knob can cause gas to leak which could result in fire or explosion.

Properly operating your furnace requires certain abilities, mechanical skills and tools. If you are uncertain about your abilities or if you lack proper skills or tools, do not proceed. Instead, contact a qualified installer, service agency or gas supplier.

An automatic ignition device lights the burners. Do not try to light manually. See Figure 2 on Page 8 for step by step instructions.

SECTION 6 • PROPER MAINTENANCE OF YOUR FURNACE

You need special abilities, mechanical skills and tools to maintain your furnace properly. If you are uncertain about your abilities or if you lack proper skills or tools, do not try to maintain or repair your furnace yourself. Instead, contact a qualified installer, service agency or gas supplier.

6.A IF YOU SMELL GAS OR ANY UNFAMILIAR SMELL WHILE WORKING ON YOUR FURNACE:

- 1. Do not try to light main burners.
- 2. Do not touch or turn on any electrical switch.
- 3. Do not use any phone in your building.
- 4. Immediately call your gas supplier from a neighbor's phone. Follow gas supplier's instructions.
- 5. If you cannot reach your gas supplier, call fire department.

6.B LUBRICATION REQUIREMENTS

The main blower motor, outdoor fan motor, and the induced draft blower motor are permanently lubricated, and no maintenance is required.

6.C MAKE SURE AIR FILTER(S) IS IN PLACE

Ask your installer, local qualified service technician or gas supplier to make sure your filter(s) is in place properly. Become familiar with its location and procedures for removing, cleaning and replacing it.

Recommended filter sizes are shown below.

Main System Filter: 20 X 30 X 2 Throwaway

See Figure 3 on Page 10 for filter locations.

 WARNING
Operating furnace without clean air filter(s) can damage blower motor, heat exchanger or air conditioning system components. This can cause system failure which could result in damage or injury.

FIGURE 2
START UP PROCEDURE

FOR YOUR SAFETY READ BEFORE OPERATING

WARNING: If you do not follow these instructions exactly, a fire or explosion may result causing property damage, personal injury or loss of life.

- A. This appliance does not have a pilot. It is equipped with an ignition device which automatically lights the burner. Do NOT try to light the burner by hand.
- B. BEFORE OPERATING smell all around the appliance area for gas. Be sure to smell next to the floor because some gas is heavier than air and will settle on the floor.

WHAT TO DO IF YOU SMELL GAS

- *Do not try to light any appliance.
- *Do not touch any electric switch; do not use any phone in your building.
- *Immediately call your supplier from a neighbor's phone. Follow the gas supplier's instructions.

*If you cannot reach your gas supplier; call the fire department.

- C. Use only your hand to push in or move the gas control lever. Never use tools. If the lever will not push in or turn by hand, don't try to repair it, call a qualified service technician. Force or attempted repair may result in a fire or explosion.
- D. Do not use this appliance if any part has been under water. Immediately call a qualified service technician to inspect the appliance and to replace any part of the control system and any gas control which has been under water.

OPERATING INSTRUCTIONS

1. STOP! Read the safety information above on this label.
2. Set the thermostat to lowest setting.
3. Turn off all electric power to the appliance.
4. This appliance is equipped with an ignition device which automatically lights the burner. Do NOT try to light the burner by hand.

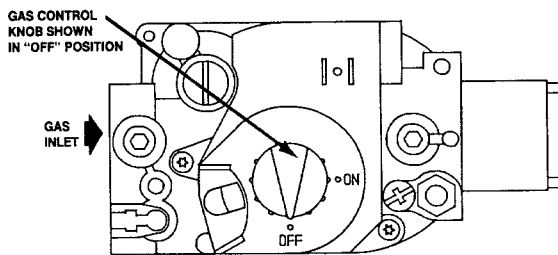

5. Remove control access panel.
6. Push in gas control knob slightly and turn clockwise to "OFF".
NOTE: Knob cannot be turned to "OFF" unless knob is pushed in slightly. Do not force.
7. Wait five (5) minutes to clear out any gas. Then smell for gas, including near the floor. If you smell gas, STOP! Follow "B" in the safety information above on this label. If you don't smell gas, go to the next step.
8. Turn gas control knob counterclockwise to "ON".
9. Replace control access panel.
10. Turn on all electric power to the appliance.
11. Set thermostat to desired setting.
12. If the appliance will not operate, follow the instructions "To Turn Off Gas To Appliance" and call your service technician or gas supplier.

TO TURN OFF GAS TO APPLIANCE

1. Set the thermostat to lowest setting.
2. Turn off all electric power to the appliance if service is to be performed.
3. Remove control access panel.
4. Push in gas control lever slightly and move to "OFF". Do not force.
5. Replace control access panel.

7961-509

6.D KEEP AIR FILTER(S) CLEAN

As a user, your personal responsibility is to keep air filter(s) clean.

CAUTION

A dirty air filter(s) reduces system efficiency and can cause erratic control performance. These could result in damage to blower motor or heat exchanger.

1. During the first four weeks after your furnace is installed, inspect your air filter(s) for dirt every week. Then check the filters monthly and replace as necessary.
2. If the filter(s) is of a washable type, clean filter(s) according to the manufacturer's specifications.

WARNING

After cleaning or changing filter(s), filter access must be closed and latched. Failure to do so could cause nausea, asphyxiation, or fire resulting in damage, injury or death.

6.E DO NOT OBSTRUCT DUCT WORK

For proper operation, keep registers and return air grilles open. Do not cover or block them with rugs, carpets, drapes or furniture.

6.F HAVE YOUR FURNACE CHECKED ANNUALLY

The furnace, vent terminal, and the combustion air intake hood should be inspected yearly by a qualified service agency, generally prior to the heating season. Detailed procedures for this inspection are contained in the instructions booklet and should be handled by the qualified service agency only.

A general inspection of the furnace, the furnace area and the vent terminal should be conducted on a regular basis by the owner/occupant. This review should include:

1. Make sure the furnace always has the minimum clearance as detailed on the

furnace rating plate. Special attention must be given to these items if any remodeling is done.

2. Make sure the vent terminal is in place and is physically sound.
3. Reviewing that the return air duct connection(s) is physically sound, is sealed to the furnace casing.
4. The physical support of the furnace is sound without sagging, cracks, gaps, etc. around the unit so as to provide a seal between the unit and the structure.
5. Inspect for any obvious signs of deterioration of the furnace.
6. Periodic examinations of the vent terminal should also be conducted by the owner on a regular basis, preferably every month but at least every two months during the heating season.
7. Check the entire vent terminal for any blockage. If any debris is present remove it.

6.G THE FOLLOWING PROCEDURE SHOULD BE FOLLOWED FOR THE PERIODIC INSPECTION AS CONDUCTED BY THE OWNER/OCCUPANT.

1. Set the wall thermostat to the OFF position or lower the set point lever to a temperature well below the existing room temperature. Shut off electric power to the furnace. A circuit breaker is located behind the lower, small access panel on the right side.
2. Remove the burner access door. See Figure 4.
3. Use flashlight or trouble light to observe the burner compartment and burners. There should be very minimal scaling or sooting in this area. Any loose debris may be vacuumed out. Also observe the sides of the heat exchanger tubes for "hot spots" due to improper burner alignment or overfiring and give particular attention to any area where it looks like there may be any deterioration from corrosion or rusting. Observe for any corrosion on the burners themselves. Should anything appear questionable, contact your service agency.
4. Inspect the vent terminal, or vent system observing for any debris from weather, birds, and the like. Clean if necessary. Also check the combustion air inlet hood to make sure it is clear. See Figure 4.

**FIGURE 3
FILTER LOCATIONS**

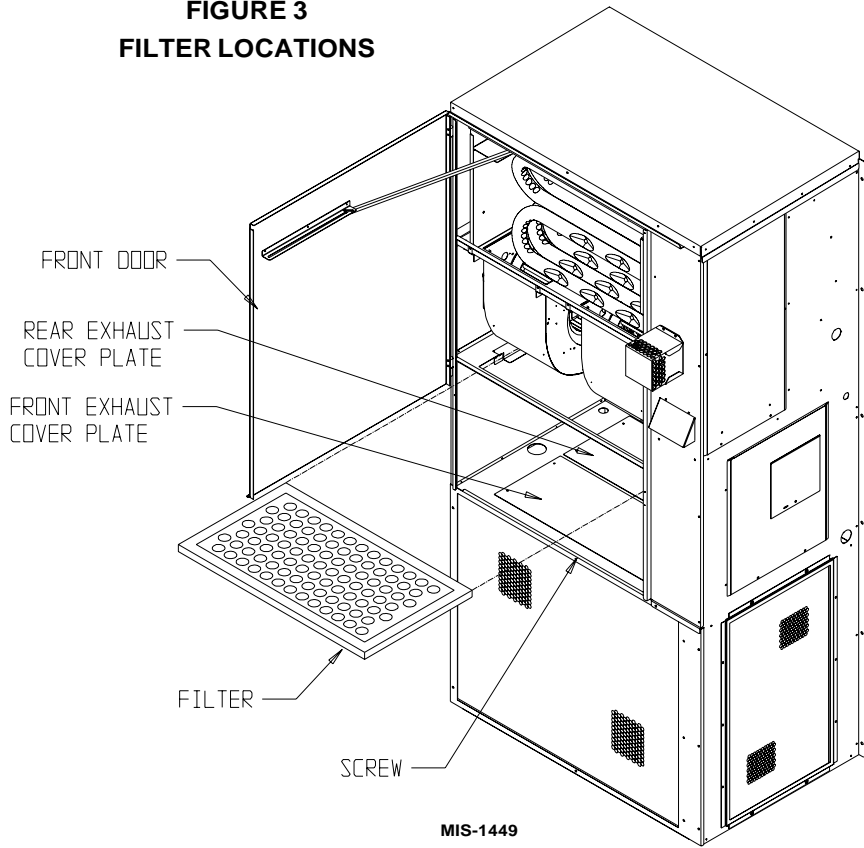

**FIGURE 4
PERIODIC INSPECTIONS**

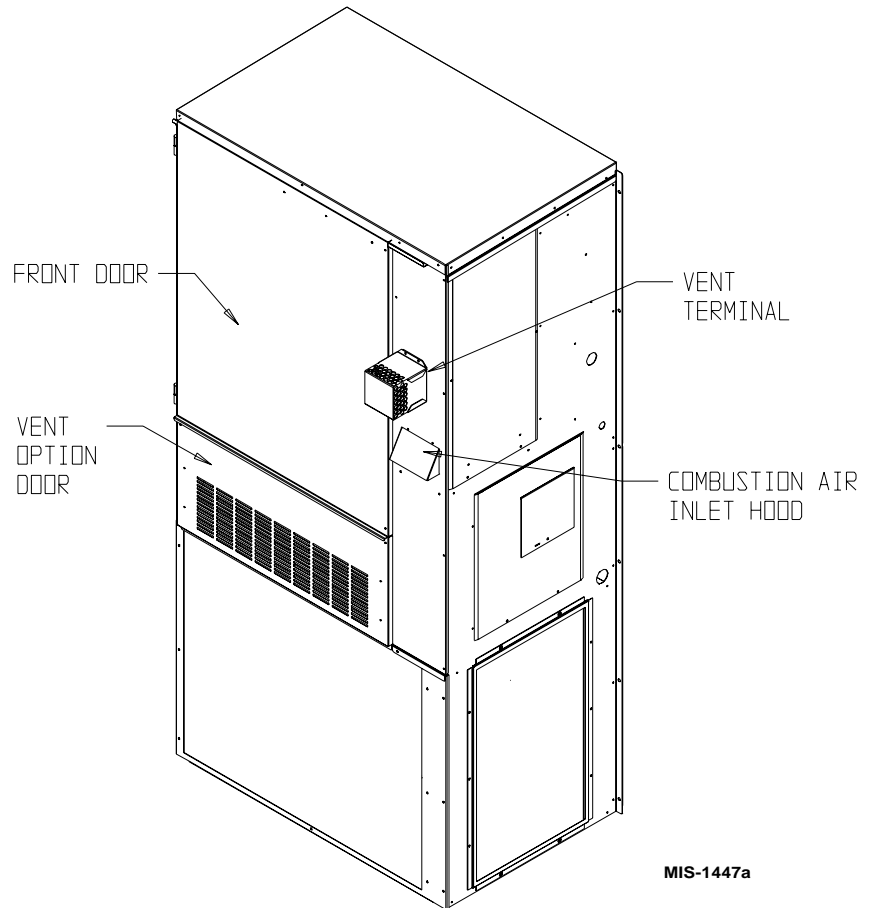

WARNING

Leakage of products of combustion into the living area may result in asphyxiation resulting in injury or death

5. Restore the electrical power to the furnace by turning the switch back on. Adjust the thermostat to call for heating operation.
6. Observe the main burners flames, and respectively. The main burners should be mostly “blue” with possibly a little orange (not yellow) at the tips of the flames. The flames should be in the center of the heat exchanger compartments and not impinging on the heat exchanger surfaces.
7. Observe the flames until the blower starts (there is a normal delay 30 second period until the heat exchanger warms up). There should be no change in the size or shape of the flame. If there is any wavering or blowing of the flame on the blower start-up, it is an indication of a possible leak in the heat exchanger. Turn off the gas valve in the gas line leading to the furnace, and then the main electrical switch to the furnace and call your service agency.
8. Replace the burner access door.

SECTION 7 • AIR CONDITIONING START UP PROCEDURE CRANKCASE HEATERS FOR NON-SCROLL COMPRESSOR UNITS

Some single and three phase models have an insertion well-type heater located in the lower section of the compressor housing. This is a self-regulating type heater that draws only enough power to maintain the compressor at a safe temperature.

Some form of crankcase heat is essential to prevent liquid refrigerant from migrating to the compressor, causing oil pump out on compressor start-up and possible valve failure due to compressing a liquid.

The decal in Figure 5 is affixed to all outdoor units with crankcase heaters detailing start-up procedures. ***This is very important. Please read carefully.***

**FIGURE 5
START-UP PROCEDURES DECAL**

IMPORTANT

These procedures must be followed at initial start-up and at any time power has been removed for 12 hours or longer.

To prevent compressor damage which may result from the presence of liquid refrigerant in the compressor crankcase.

1. Make certain the room thermostat is in the “off” position (the compressor is not to operate).
2. Apply power by closing the system disconnect switch. This energizes the compressor heater which evaporates the liquid refrigerant in the crankcase.
3. Allow 4 hours or 60 minutes per pound of refrigerant in the system as noted on the unit rating plate, whichever is greater.
4. After properly elapsed time, the thermostat may be set to operate the compressor.
5. Except as required for safety while servicing—Do not open system disconnect switch.

7961-061

SECTION 8 • VENTILATION OPTION ASSEMBLIES

The standard Barometric Fresh Air Damper (BFAD) allows up to 25% outside fresh air to be introduced to the building whenever the main unit comfort air blower is operating.

The optional Blank Off Plate (BOP) is installed on the inside of the vent option door to cover the air inlet openings which eliminates outside air from entering the unit.

The optional Motorized Fresh Air Damper (MFAD) allows up to 25% outside fresh air to be introduced to the building through a two position damper which can be fully open or closed.

The optional Commercial Room Ventilator (CRV) allows up to 50% outside fresh air to be introduced to the building and includes a built-in exhaust damper. The CRV complies with ASHRAE Standard 62-89 “Ventilation for Acceptable Indoor Air Quality”.

SECTION 9 • REPLACEMENT PARTS

Replacement parts for the gas/electric units are available through local distributors.

A replacement parts list manual is supplied with each unit. When ordering parts or making inquiries pertaining to any of the units covered by these instructions, it is very important to always supply the complete model number and serial number of the unit. This is necessary to assure that the correct parts (or an approved alternate part) are issued to the service agency.

SECTION 10 • OUTDOOR COIL

Period cleaning of the outdoor coil to permit full and unrestricted airflow circulation is essential. Reduced airflow through the outdoor coil can shorten equipment service life as well as increase operating costs.