
INSTALLATION INSTRUCTIONS

WALL MOUNTED PACKAGE HEAT PUMP

Model
WH242D



Bard Manufacturing Company
Bryan, Ohio 43506
Since 1914....Moving ahead just as planned.

Manual : 2100-374C
Supersedes: 2100-374B
File: Volume III Tab 17
Date: 05-13-02

CONTENTS

Getting Other Informations and Publications

Wall Mount General Information

Heat Pump Wall Mount Model Nomenclature	2
Shipping Damage	2
General	2
Duct Work	4
Filters	5
Fresh Air Intake	5
Condensate Drain	5

Installation Instructions

Wall Mounting Information	6
Mounting the Unit	6
Wiring – Main Power	6
Wiring – Low Voltage Wiring	12
Thermostat Indicator Lamps	12
Compressor Malfunction Light	12

Figures

Figure 1 Unit Dimensions	3
Figure 2 Fresh Air Damper Assembly	5
Figure 3 Mounting Instructions	7
Figure 4 Wall Mounting Instructions	8
Figure 5 Wall Mounting Instructions	8
Figure 6 Common Wall Mounting Installations	9
Figure 7 Hot Gas Reheat During Dehumidification with CS200	12
Figure 8 Hot Gas Reheat During Dehumidification with Programmable Thermostat	13
Figure 9 Start Up Procedure Decal	13
Figure 10 Defrost Control Board	15
Figure 11 Fan Blade Setting	18
Figure 12 Circuit Diagram H/P Cooling Mode	21
Figure 13 Circuit Diagram H/P Dehumidification ...	21

Start Up

Important Installer Note	13
Crankcase Heaters	13
Service Hints	13
Sequence of Operation	13
Pressure Service Ports	14
Defrost Cycle	14

Troubleshooting

Solid State Heat Pump Control Troubleshooting Procedure	16
Checking Temperature Sensor Outside Unit Circuit	17
Temperature vs Resistance of Temperature Sensor	17
Fan Blade Setting Dimensions	18
Removal of Fan Shroud	18
Refrigerant Charge	18
Pressure Tables	19
Optional Accessories	20

Tables

Table 1 Electric Heat Table	2
Table 2 Electrical Specifications	4
Table 3 Thermostat Wire Size	12
Table 4 Wall Thermostat and Subbase Combinations	12
Table 5 Troubleshooting	16
Table 6 Fan Blade Dimensions	18
Table 7 Suction Line Temperatures	18
Table 8 Indoor Blower Performance	18
Table 9 Rated CFM and Raded ESP	18
Table 10 Maximum ESP of Operation	18
Table 11 Pressure Table – Cooling	19
Table 12 Pressure Table – Heating	19
Table 13 Optional Accessories	20

Getting Other Information and Publications

These publications can help you install the air conditioner or heat pump. You can usually find these at your local library or purchase them directly from the publisher. Be sure to consult current edition of each standard.

National Electrical Code ANSI/NFPA 70

Standard for the Installation ANSI/NFPA 90A
of Air Conditioning and
Ventilating Systems

Standard for Warm Air ANSI/NFPA 90B
Heating and Air
Conditioning Systems

Load Calculation for ACCA Manual J
Residential Winter and
Summer Air Conditioning

Duct Design for Residential ACCA Manual D
Winter and Summer Air Conditioning
and Equipment Selection

For more information, contact these publishers:

ACCA **Air Conditioning Contractors of America**
1712 New Hampshire Ave. N.W.
Washington, DC 20009
Telephone: (202) 483-9370
Fax: (202) 234-4721

ANSI **American National Standards Institute**
11 West Street, 13th Floor
New York, NY 10036
Telephone: (212) 642-4900
Fax: (212) 302-1286

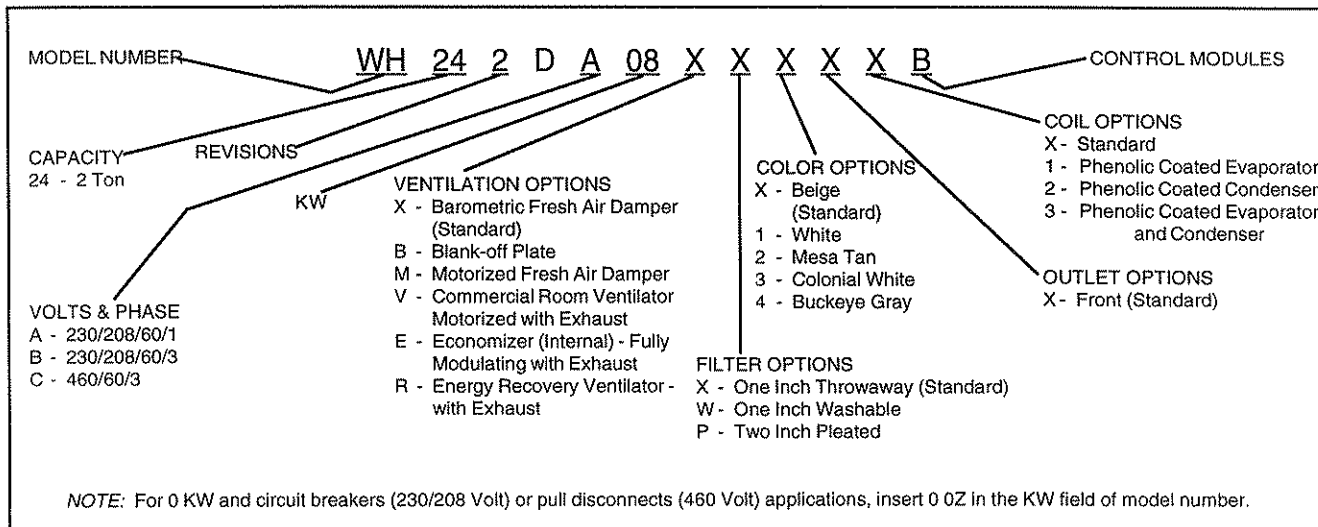
ASHRAE **American Society of Heating Refrigerating,
and Air Conditioning Engineers, Inc.**
1791 Tullie Circle, N.E.
Atlanta, GA 30329-2305
Telephone: (404) 636-8400
Fax: (404) 321-5478

NFPA **National Fire Protection Association**
Batterymarch Park
P.O. Box 9101
Quincy, MA 02269-9901
Telephone: (800) 344-3555
Fax: (617) 984-7057

Manufactured under the following U.S. Patent numbers:
5,485,878; 5,301,777; 5,002,116; 4,924,934;
4,875,520; 4,825,936

WALL MOUNT GENERAL INFORMATION

HEAT PUMP WALL MOUNT MODEL NOMENCLATURE



**TABLE 1
ELECTRIC HEAT TABLE**

Models	WH242DA				WH242DB				WH242DC	
	240-1		208-1		240-3		208-3		460-3	
	A	BTU	A	BTU	A	BTU	A	BTU	A	BTU
4	16.7	13650	14.4	10240						
8	33.3	27300	28.8	20475						
6					14.4	20500	12.5	15360	7.2	20475

SHIPPING DAMAGE

Upon receipt of equipment, the carton should be checked for external signs of shipping damage. If damage is found, the receiving party must contact the last carrier immediately, preferably in writing, requesting inspection by the carrier's agent.

GENERAL

The equipment covered in this manual is to be installed by trained, experienced service and installation technicians.

The refrigerant system is completely assembled and charged. All internal wiring is complete.

The unit is designed for use with or without duct work. Flanges are provided for attaching the supply and return ducts.

These instructions explain the recommended method to install the air cooled self-contained unit and the electrical wiring connections to the unit.

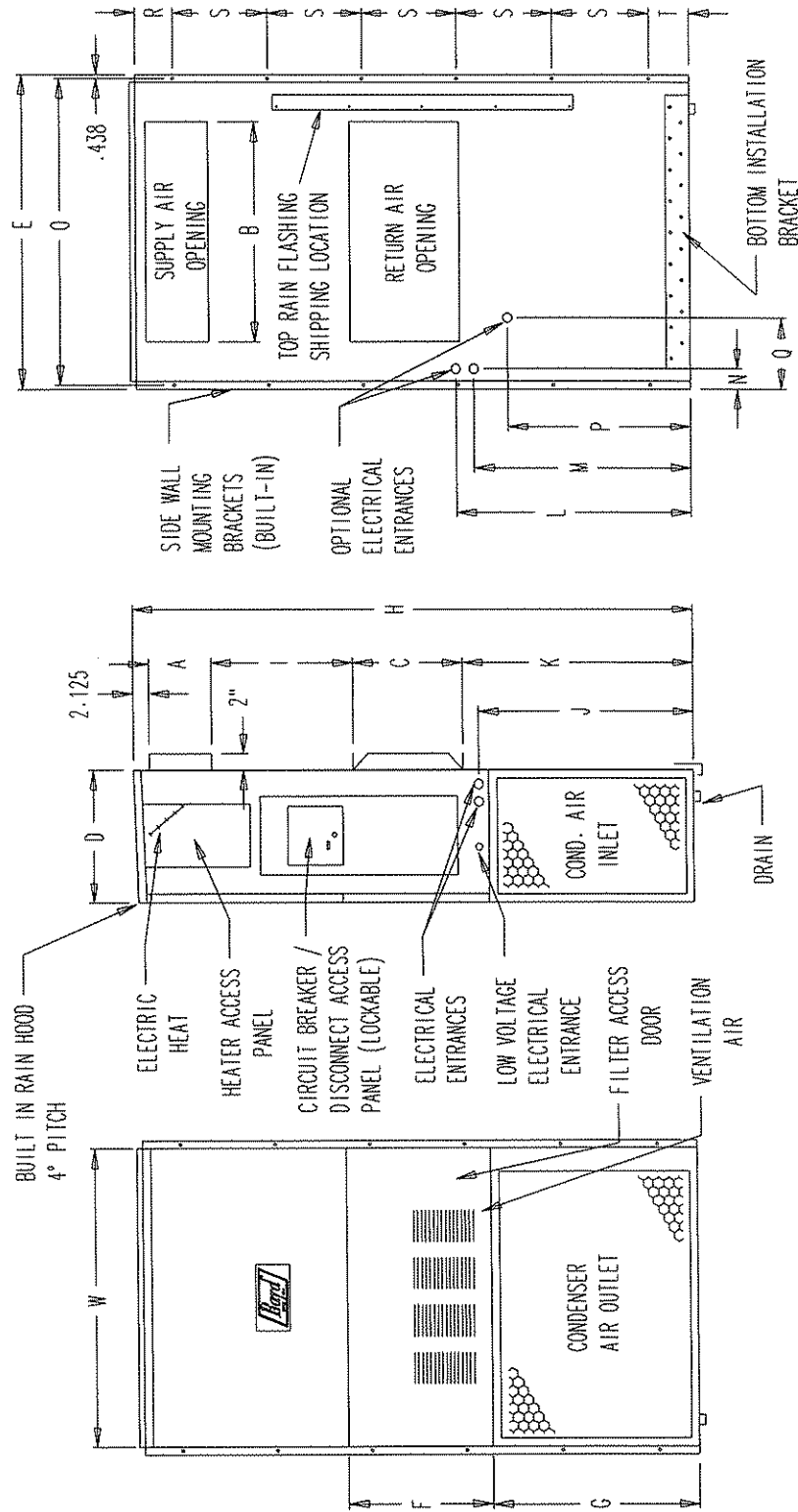
These instructions and any instructions packaged with any separate equipment required to make up the entire air conditioning system should be carefully read before beginning the installation. Note particularly "Starting Procedure" and any tags and/or labels attached to the equipment.

While these instructions are intended as general recommended guide, they do not supersede any national and/or local codes in any way. Authorities having jurisdiction should be consulted before the installation is made. See Page 1 for information on codes and standards.

Size of unit for a proposed installation should be based on heat loss calculation made according to methods of

**FIGURE 1
UNIT DIMENSIONS**

Unit	Width (W)	Depth (D)	Height (H)	Supply			Return			E	F	G	I	J	K	L	M	N	O	P	Q	R	S	T
				A	B	C	D																	
WH242D	33.30	17.125	70.563	7.88	19.88	11.88	19.88	35.00	18.50	25.75	20.56	26.75	28.06	29.25	27.00	2.63	34.13	27.06	10.55	4.19	12.00	5.00		



FRONT VIEW

SIDE VIEW

BACK VIEW

MIS-1261

**TABLE 2
ELECTRICAL SPECIFICATIONS**

SINGLE CIRCUIT						
Model	Rated Volts and Phase	No. Field Power Circuits	③ Minimum Circuit Ampacity	① Maximum External Fuse or Circuit Breaker	② Field Power Wire Size	② Ground Wire Size
WH242DA00, A0Z A04 A08	230/208-1	1	18	25	12	12
		1	39	40	10	10
		1	60	60	6	10
WH242DB00, B0Z B06	230/208-1	1	15	20	12	12
		1	33	35	8	10
WH241DC00, C0Z C06	460-3	1	8	15	14	14
		1	17	20	12	12

- ① Maximum size of the time delay fuse or HACR type circuit breaker for protection of field wiring conductors.
- ② Based on 75° C copper wire. All wiring must conform to NEC and all local codes.
- ③ These "Minimum Circuit Ampacity" values are to be used for sizing the field power conductors. Refer to the National Electric Code (latest revision), article 310, for power conductor sizing. *CAUTION: When more than one field power conductor circuit is run through one conduit the conductors must be derated. Pay special attention to note 89 of table 310 regarding Ampacity Adjustment Factors when more than 3 are in a raceway.*

Air Conditioning Contractors of America (ACCA). The air duct should be installed in accordance with the Standards of the National Fire Protection Association for the Installation of Air Conditioning and Ventilating systems of Other Than Residence Type, NFPA No. 90A, and Residence Type Warm Air Heating and Air Conditioning Systems, NFPA No. 90B. Where local regulations are at a variance with instructions, installer should adhere to local codes.

DUCT WORK

Any heat pump is more critical of proper operating charge and an adequate duct system than a straight air conditioning unit. All duct work, supply and return, must be properly sized for the design air flow requirement of the equipment. Air Conditioning Contractors of America (ACCA) is an excellent guide to proper sizing. All duct work or portions thereof not in the conditioned space should be properly insulated in order to both conserve energy and prevent condensation or moisture damage.

Refer to Table 10 for maximum static pressure available for duct design.

Design the duct work according to methods given by the Air Conditioning Contractors of America (ACCA). When duct runs through unheated spaces, it should be insulated with a minimum of one inch of insulation. Use insulation with a vapor barrier on the outside of the insulation. Flexible joints should be used to connect the duct work to the equipment in order to keep the noise transmission to a minimum.

A 1/4 inch clearance to combustible material for the first three feet of duct attached to the outlet air frame is required. See Pages Wall Mounting Instructions and Figure 3 for further details.

Ducts through the walls must be insulated and all joints taped or sealed to prevent air or moisture from entering the wall cavity.

CAUTION: Some installations may not require any return air duct. A metallic return air grille is required with installations not requiring a return air duct. The spacing between louvers on the grille shall not be larger than 5/8 inches.

Any grille that meets the 5/8 inch louver criteria may be used. It is recommended that Bard Return Air Grille Kit RG2 thru RG5 or RFG2 thru RFG5 be installed when no return duct is used. Contact distributor or factory for ordering information. If using a return air filter grille, filters must be of sufficient size to allow a maximum velocity of 400 fpm.

NOTE: If no return air duct is used, applicable installation codes may limit this cabinet to installation only in a single story structure.

FILTERS

A 1 inch throwaway filter is supplied with each unit. The filter slides into position making it easy to service. This filter can be serviced from the outside by removing the service door. A 1 inch washable filter and a 2 inch pleated filter are also available as optional accessories. The internal filter brackets are adjustable to accommodate the 2 inch filter by loosening two (2) screws in each bracket assembly and sliding the brackets apart to the required width and retightening the four (4) screws.

FRESH AIR INTAKE

All units are built with fresh air inlet slots punched in the service panel.

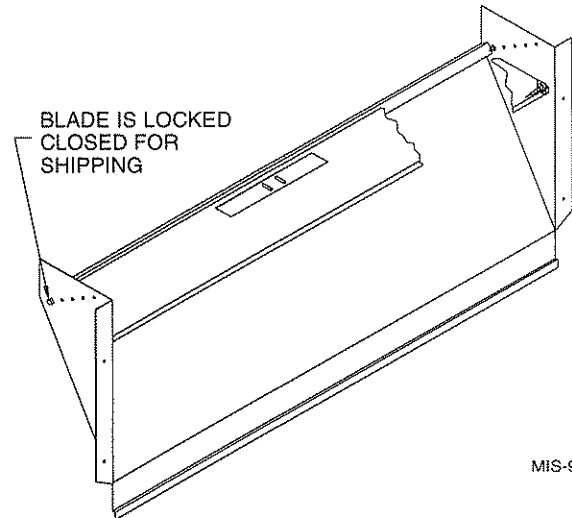
If the unit is equipped with a fresh air damper assembly, the assembly is shipped already attached to the unit. The damper blade is locked in the closed position. To allow the damper to operate, the maximum and minimum blade position stops must be installed. See Figure 2.

All capacity, efficiency, and cost of operation information as required for Department of Energy "Energyguide" Fact Sheets is based upon the fresh air

blank-off plate in place and is recommended for maximum energy efficiency.

The blank-off plate is available upon request from the factory and is installed in place of the fresh air damper shipped with each unit.

**FIGURE 2
FRESH AIR DAMPER ASSEMBLY**



MIS-938

CONDENSATE DRAIN

A plastic drain hose extends from the drain pan at the top of the unit down to the unit base. There are openings in the unit base for the drain hose to pass through. In the event the drain hose is connected to a drain system of some type, it must be an open or vented type system to assure proper drainage.

INSTALLATION INSTRUCTIONS

WALL MOUNTING INFORMATION

1. These units are secured by wall mounting brackets which secure the unit to the outside wall surface at both sides. A bottom mounting bracket is provided for ease of installation, but is not required.
2. On wood frame walls, the wall construction must be strong and rigid enough to carry the weight of the unit without transmitting any unit vibration.
3. Concrete block walls must be thoroughly inspected to insure that they are capable of carrying the weight of the unit being installed.
4. The unit is suitable for 0 inch clearance from the unit, and from the supply and return air ducts.

MOUNTING THE UNIT

1. Two holes for the supply and return air openings must be cut through the wall as shown in Figure 3.
2. Locate and mark lag bolt locations and bottom mounting bracket location, if desired. See Figure 3.
3. Mount bottom mounting bracket, if used.
4. Hook top rain flashing under back bend of top. Top rain flashing is shipped secured to the right side of the back.
5. Position unit in opening and secure with 5/16 lag bolts. Use 5/16" flat washers on the lag bolts.
6. Secure rain flashing to wall and caulk across entire length of top. See Figure 3.
7. For additional mounting rigidity, the return air and supply air frames or collars can be drilled and screwed or welded to the structural wall itself (depending upon wall construction). Be sure to observe required clearance if combustible wall.
8. On side by side installations, maintain a minimum of 20 inches clearance on right side of unit to allow access to control panel and heaters, and to allow proper airflow to the outdoor coil. Additional clearance may be required to meet local or national codes.

WIRING – MAIN POWER

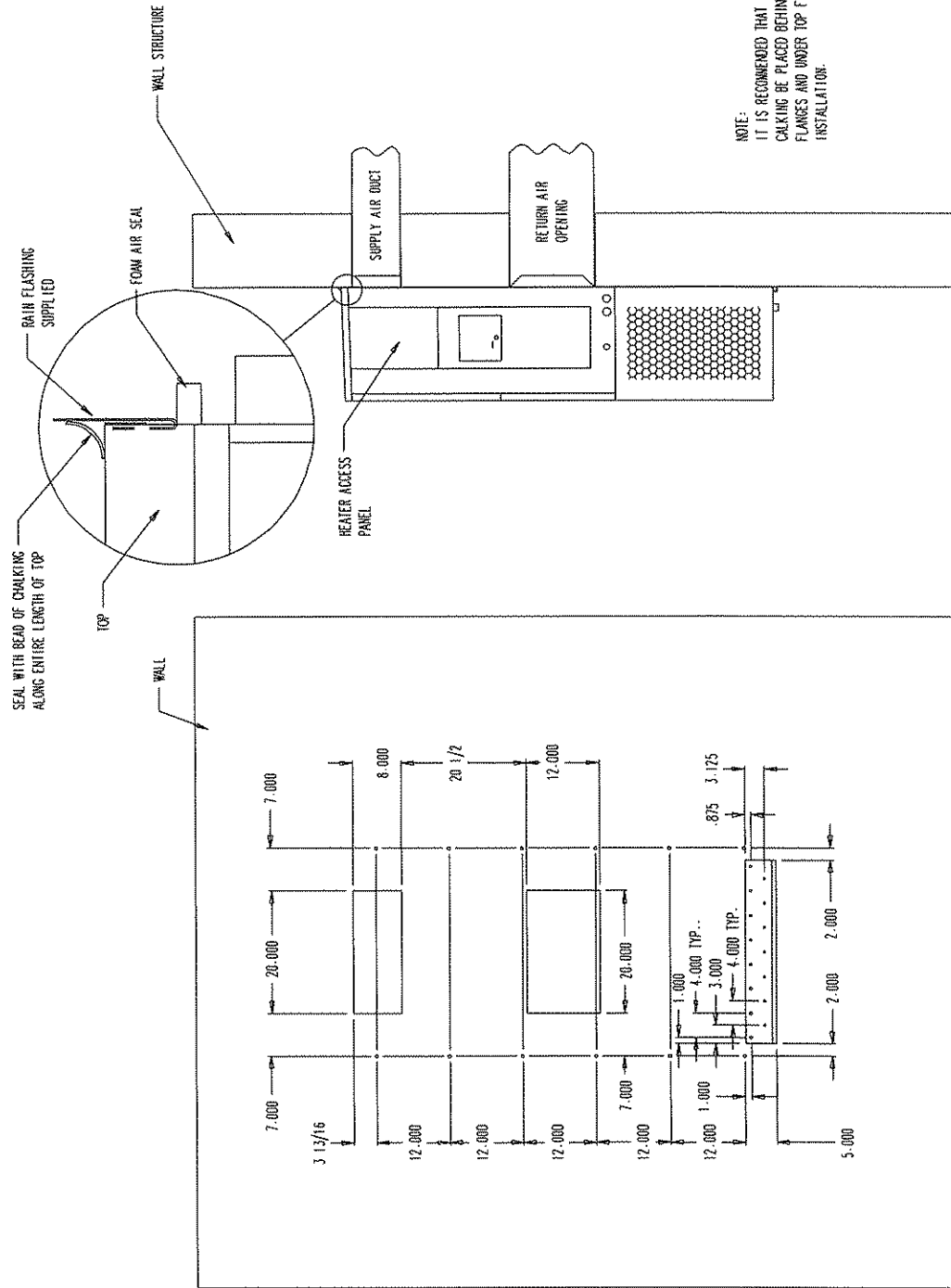
Refer to the unit rating plate for wire sizing information and maximum fuse or "HACR" type circuit breaker size. Each outdoor unit is marked with a "Minimum Circuit Ampacity". This means that the field wiring used must be sized to carry that amount of current. Depending on the installed KW of electric heat, there may be two field power circuits required. If this is the case, the unit serial plate will so indicate. All models are suitable only for connection with copper wire. Each unit and/or wiring diagram will be marked "Use Copper Conductors Only". ***These instructions must be adhered to.*** Refer to the National Electrical code (NEC) for complete current carrying capacity data on the various insulation grades of wiring material. All wiring must conform to NEC and all local codes.

The electrical data lists fuse and wire sizes (75° C copper) for all models, including the most commonly used heater sizes. Also shown are the number of field power circuits required for the various models with heaters.

The unit rating plate lists a "Maximum Time Delay Relay Fuse" or "HACR" type circuit breaker that is to be used with the equipment. The correct size must be used for proper circuit protection and also to assure that there will be no nuisance tripping due to the momentary high starting current of the compressor motor.

The disconnect access door on this unit may be locked to prevent unauthorized access to the disconnect. To convert for the locking capability, bend the tab located in the bottom left hand corner of the disconnect opening under the disconnect access panel straight out. This tab will now line up with the slot in the door. When shut a padlock may be placed through the hole in the tab preventing entry.

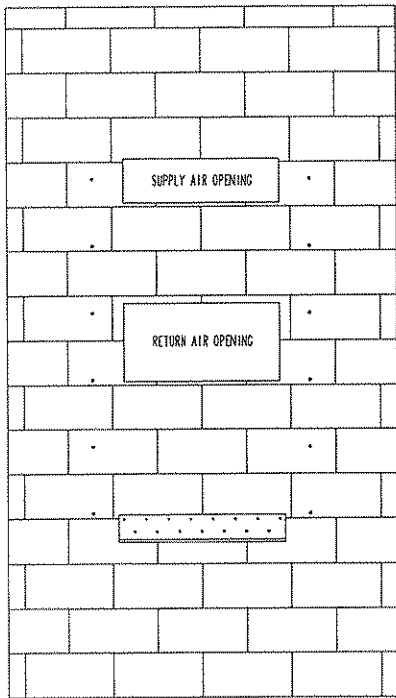
FIGURE 3
MOUNTING INSTRUCTIONS



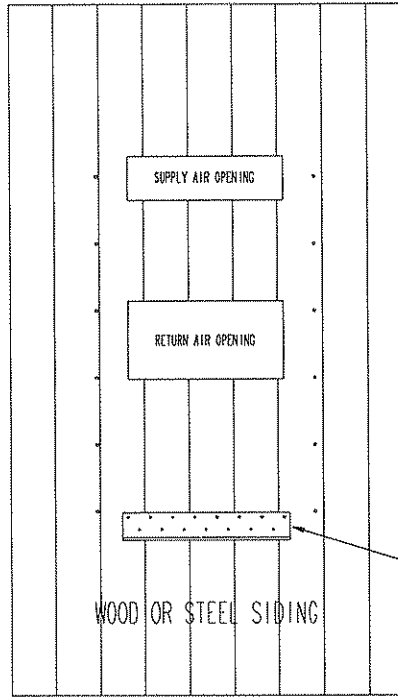
MIS-353

FIGURE 4 WALL MOUNTING INSTRUCTIONS

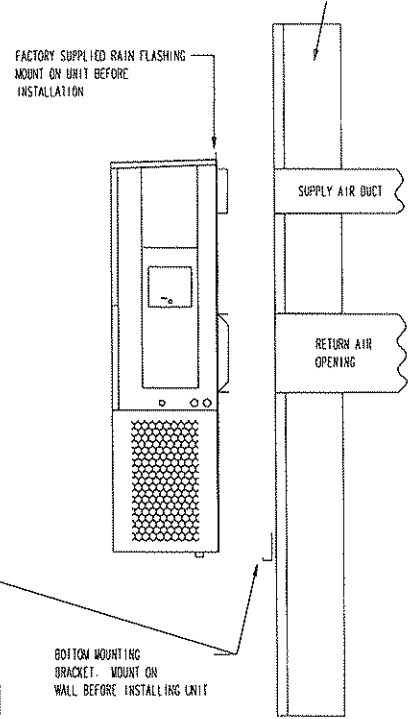
SEE FIGURE 3 - MOUNTING INSTRUCTIONS



CONCRETE BLOCK WALL INSTALLATION



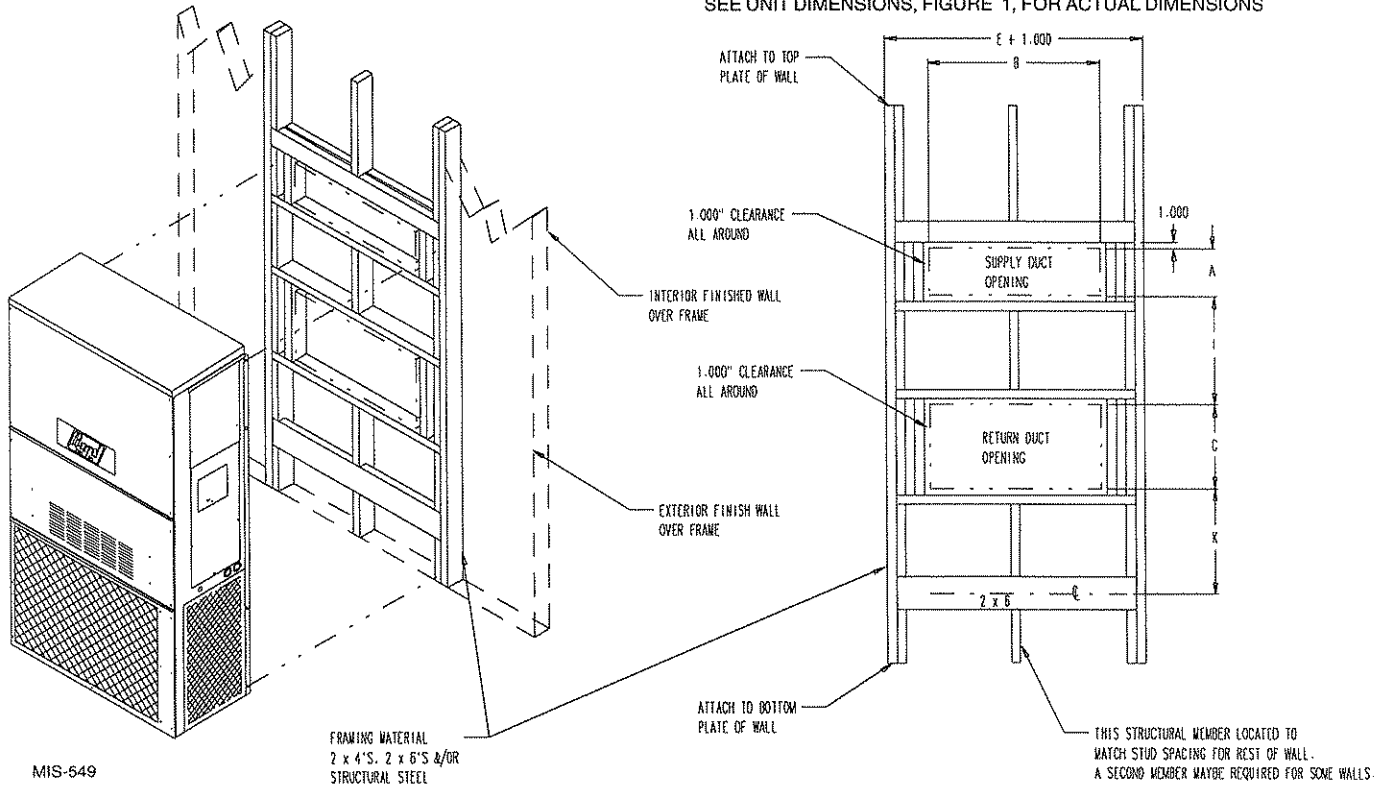
WOOD FRAME WALL INSTALLATION



MIS-548

FIGURE 5 WALL MOUNTING INSTRUCTIONS

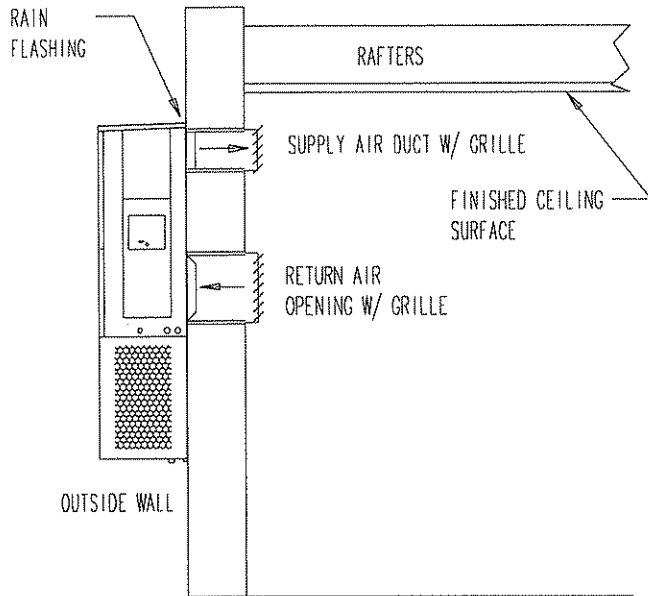
SEE UNIT DIMENSIONS, FIGURE 1, FOR ACTUAL DIMENSIONS



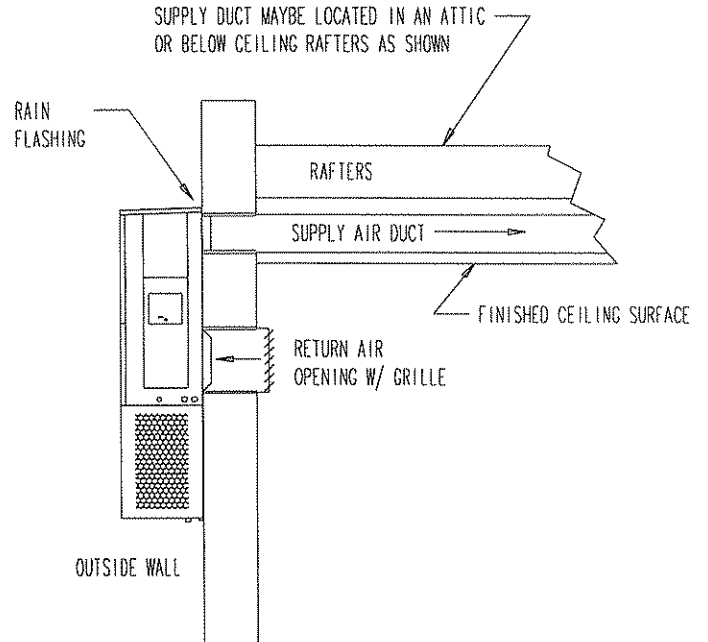
MIS-549

**FIGURE 6
COMMON WALL MOUNTING INSTALLATIONS**

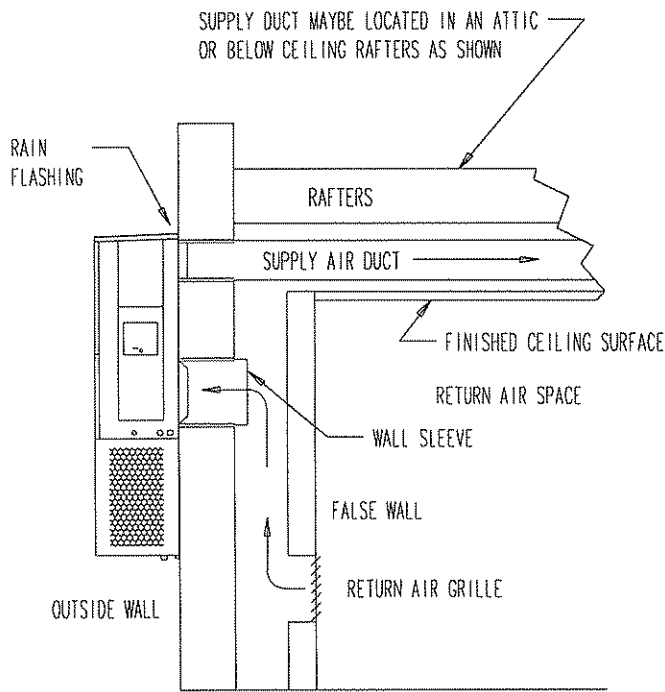
MIS-550



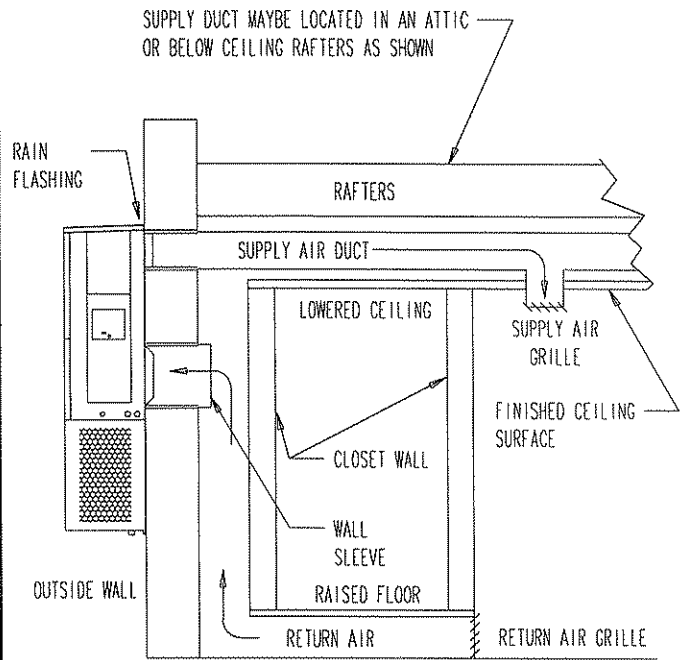
FREE AIR FLOW
NO DUCT



DUCTED SUPPLY
RETURN AT UNIT

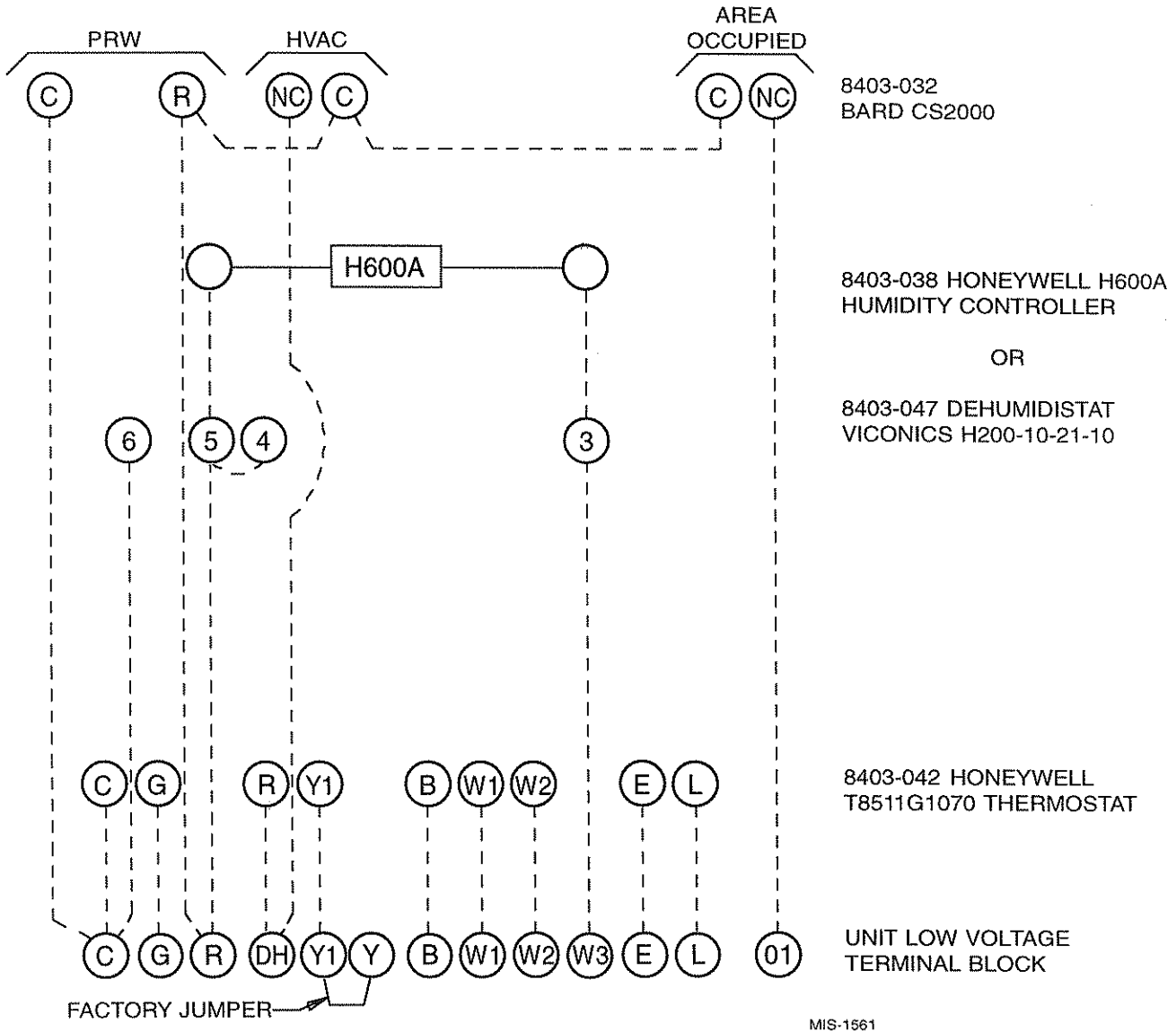


FALSE WALL INSTALLATION



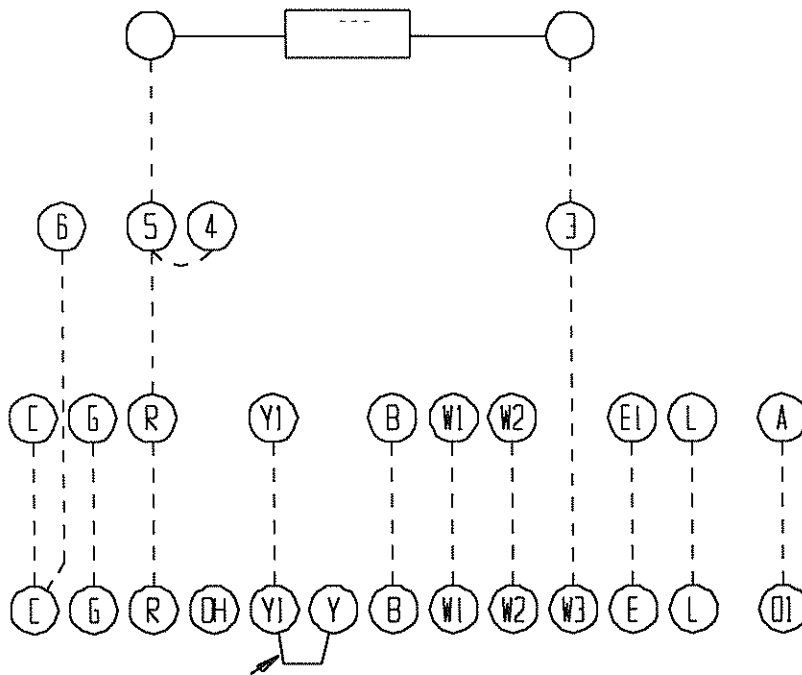
CLOSET INSTALLATION

FIGURE 7
WHxxxDx – HOT GAS REHEAT DURING DEHUMIDIFICATION
WITH CS2000 ENERGY MONITOR FULL TIME DEHUMIDIFICATION



IMPORTANT NOTE: Only the thermostat and subbase combinations as shown in Table 4 will work with this equipment. The thermostat and subbase must be matched, and the correct operation can be assured only by proper selection and application of these parts.

FIGURE 8
WHxxxDx – HOT GAS REHEAT DURING DEHUMIDIFICATION
WITH PROGRAMMABLE THERMOSTAT FULL TIME DEHUMIDIFICATION



8403-038 HONEYWELL H600A
HUMIDITY CONTROLLER

OR

8403-047 DEHUMIDISTAT
VICONICS H200-10-21-10

8403-049 WHITE-RODGERS
1F93-380 THERMOSTAT

UNIT LOW VOLTAGE
TERMINAL BLOCK

MIS-1562B

*IMPORTANT NOTE: Only the thermostat and subbase combinations as shown in Table 4 will work with this equipment. The thermostat and subbase **must** be matched, and the correct operation can be assured only by proper selection and application of these parts.*

WIRING – LOW VOLTAGE WIRING

230 / 208V, 1 phase and 3 phase equipment dual primary voltage transformers. All equipment leaves the factory wired on 240V tap. For 208V operation, reconnect from 240V to 208V tap. The acceptable operating voltage range for the 240 and 208V taps are:

<u>TAP</u>	<u>RANGE</u>
240	253 - 216
208	220 - 187

NOTE: The voltage should be measured at the field power connection point in the unit and while the unit is operating at full load (maximum amperage operating condition).

Nine (9) wires should be run from thermostat subbase to the 24V terminal board in the unit. A nine conductor, 18 gauge copper, color-coded thermostat cable is recommended.. The connection points are shown in Figures 7 and 8.

**TABLE 3
THERMOSTAT WIRE SIZE**

Transformer VA	FLA	Wire Gauge	Maximum In Feet
55	2.3	20 gauge	45
		18 gauge	60
		16 gauge	100
		14 gauge	160
		12 gauge	250

**TABLE 4
WALL THERMOSTAT AND SUBBASE
COMBINATIONS**

Thermostat	Predominant Features
8403-042 (T8511G51070)	1 stage cool; 2 stage heat Electronic Non-Programmable Auto or Manual Changeover
8403-049 1F93-380	2 stage cool; 3 stage heat 7 Day Programmable Auto or Manual Changeover

THERMOSTAT INDICATOR LAMPS

The red lamp marked “Check” will come on if there is any problem that prevents the compressor from running when it is supposed to be.

COMPRESSOR MALFUNCTION LIGHT

Actuation of the red lamp is accomplished by a relay output from the heat pump control board which is factory installed. Any condition such as high head pressure, etc., that will prevent compressor from operating will cause red lamp to activate. This is a signal to the operator of the equipment to place system in emergency heat position.

IMPORTANT INSTALLER NOTE

For improved start up performance, wash the indoor coil with a dish detergent.

CRANKCASE HEATERS

WH241 units are provided with compressor crankcase heat.

These models have an insertion well-type heater located in the lower section of the compressor housing. This is a self-regulating type heater that draws only enough power to maintain the compressor at a safe temperature.

Some form of crankcase heat is essential to prevent liquid refrigerant from migrating to the compressor causing oil pump out on compressor start up and possible valve failure.

The decal in Figure 9 is affixed to all outdoor units detailing start up procedure. *This is very important. Please read carefully.*

SERVICE HINTS

1. Caution homeowner to maintain clean air filters at all times. Also, not to needlessly close off supply and return air registers. This reduces air flow through the system which shortens equipment service life as well as increasing operating costs.
2. Switching to heating cycle at 75° F or higher outside temperature may cause a nuisance trip of the remote reset high pressure switch. Turn thermostat off, then on, to reset the high pressure switch..
3. The heat pump wall thermostats perform multiple functions. Be sure that all function switches are correctly set for the desired operating mode before trying to diagnose any reported service problems.
4. Check all power fuses or circuit breakers to be sure they are the correct rating.
5. Periodic cleaning of the outdoor coil to permit full and unrestricted airflow circulation is essential.

SEQUENCE OF OPERATION

COOLING – Circuit R-Y makes at thermostat pulling in compressor contactor, starting the compressor and outdoor motor. The G (indoor motor) circuit is automatically completed on any call for cooling operation or can be energized by manual fan switch on subbase for constant air circulation.

**FIGURE 9
START UP LABEL**

IMPORTANT

THESE PROCEDURES MUST BE FOLLOWED AT INITIAL START UP AND AT ANY TIME POWER HAS BEEN REMOVED FOR 12 HOURS OR LONGER.

TO PREVENT COMPRESSOR DAMAGE WHICH MAY RESULT FROM THE PRESENCE OF LIQUID REFRIGERANT IN THE COMPRESSOR CRANKCASE:

1. MAKE CERTAIN THE ROOM THERMOSTAT IS IN THE "OFF" POSITION. (THE COMPRESSOR IS NOT TO OPERATE.)
2. APPLY POWER BY CLOSING THE SYSTEM DISCONNECT SWITCH. THIS ENERGIZES THE COMPRESSOR HEATER WHICH EVAPORATES THE LIQUID REFRIGERANT IN THE CRANKCASE.
3. ALLOW 4 HOURS OR 60 MINUTES PER POUND OF REFRIGERANT IN THE SYSTEM AS NOTED ON THE UNIT RATING PLATE, WHICHEVER IS GREATER.
4. AFTER PROPERLY ELAPSED TIME THE THERMOSTAT MAY BE SET TO OPERATE THE COMPRESSOR.
5. EXCEPT AS REQUIRED FOR SAFETY WHILE SERVICING — **DO NOT OPEN SYSTEM DISCONNECT SWITCH.**

7961-061

HEATING – A 24V solenoid coil on reversing valve controls heating cycle operation. Two thermostat options, one allowing "Auto" changeover from cycle to cycle and the other constantly energizing solenoid coil during heating season, and thus eliminating pressure equalization noise except during defrost, are to be used. On "Auto" option a circuit is completed from R-W1 and R-Y on each heating "on" cycle, energizing reversing valve solenoid and pulling in compressor contactor starting compressor and outdoor motor. R-G also make starting indoor blower motor. Heat pump heating cycle now in operation. The second option has no "Auto" changeover position, but instead energizes the reversing valve solenoid constantly whenever the

system switch on subbase is placed in "Heat" position, the "B" terminal being constantly energized from R. A Thermostat demand for heat completes R-Y circuit, pulling in compressor contactor starting compressor and outdoor motor. R-G also make starting indoor blower motor.

OCCUPIED MODE

VENTILATION SEQUENCE – The ERV and indoor blower will be continuously energized when the timer is energized.

COOLING SEQUENCE – On a call for cooling, the compressor of the unit is energized to provide cooling. A call for cooling cancels dehumidification mode. Cooling mode is only available when the timer is energized.

HEATING SEQUENCE – On a call for heating, the compressor and reversing valve of the unit are energized to provide heat pump heating. If the room temperature falls below the 2nd stage heating set point backup electric heat is energized. Heat pump heating is only available when the timer is energized. If heating is energized any call for dehumidification is ignored. If dehumidification is already energized a call for 2nd stage heating is needed to cancel dehumidification mode.

DEHUMIDIFICATION SEQUENCE – On a call for dehumidification the compressor and three way valve of the unit are energized to provide dehumidification. Dehumidification mode will continue until the humidistat is satisfied. If the room temperature falls below 1st stage heating setpoint, electric heat will be energized by the room thermostat and cycle to maintain room temperature. If 2nd stage heating setpoint is reached, dehumidification is de-energized and heat pump heating is energized. A call for cooling cancels dehumidification mode.

UNOCCUPIED MODE

Cooling, heating, emergency heat and ventilation are inhibited.

DEHUMIDIFICATION SEQUENCE – On a call for dehumidification the compressor and three way valve of the unit are energized to provide dehumidification. Dehumidification mode will continue until the humidistat is satisfied. If the room temperature falls below 65 degrees and dehumidification is energized, electric heat will be energized by the return air thermostat and cycle to maintain room temperature.

OTHER CONTROL SEQUENCE

Any time the indoor coil temperature falls below 32 degrees the compressor will be de-energized by the evaporator defrost sensor until the coil temperature rises above 57 degrees.

PRESSURE SERVICE PORTS

High and low pressure service ports are installed on all units so that the system operating pressures can be observed. Pressure curves can be found later in the manual covering all models on both cooling and heating cycles. It is imperative to match the correct pressure curve to the unit by model number.

DEFROST CYCLE

The defrost cycle is controlled by temperature and time on the solid state heat pump control. See Figure 10.

When the outdoor temperature is in the lower 40° F temperature range or colder, the outdoor coil temperature is 32° F or below. This coil temperature is sensed by the coil sensor mounted near the bottom of the outdoor coil. Once coil temperature reaches 30° F or below, the coil sends a signal to the control logic of the heat pump control and the defrost timer will start.

After 30 minutes at 30° F or below, the heat pump control will place the system in the defrost mode.

During the defrost mode, the refrigerant cycle switches back to the cooling cycle, the outdoor motor stops, electric heaters are energized, and hot gas passing through the outdoor coil melts any accumulated frost. When the temperature rises to approximately 57° F, the coil sensor will send a signal to the heat pump control which will return the system to heating operations automatically.

If some abnormal or temporary condition such as a high wind causes the heat pump to have a prolonged defrost cycle, the heat pump control will restore the system to heating operation automatically after 10 minutes.

There are three settings on the heat pump control – 30 minute, 60 minute, and 90 minute. Models are shipped wired on the 30 minute setting for greatest operating economy. If special circumstances require a change to another time, remove wire connected to terminal 30 and reconnect to desired terminal. Refer to Figure 10. The manufacturer's recommendation is for 3 minute defrost cycles.

There is a cycle speed up jumper on the control. This can be used to reduce the time between defrost cycle operation without waiting for time to elapse.

Use a small screwdriver or other metallic object, or another 1/4 inch QC, to short between the *SPEEDUP* terminals to accelerate the HPC timer and initiate defrost.

Be careful not to touch any other terminals with the instrument used to short the *SPEEDUP* terminals. It may take up to 10 seconds with the *SPEEDUP* terminals shorted for the speedup to be completed and the defrost cycle to start.

As soon as the defrost cycle kicks in remove the shorting instrument from the SPEEDUP terminals. Otherwise the timing will remain accelerated and run through the 1 minute maximum defrost length sequence in a matter of seconds and will automatically terminate the defrost sequence.

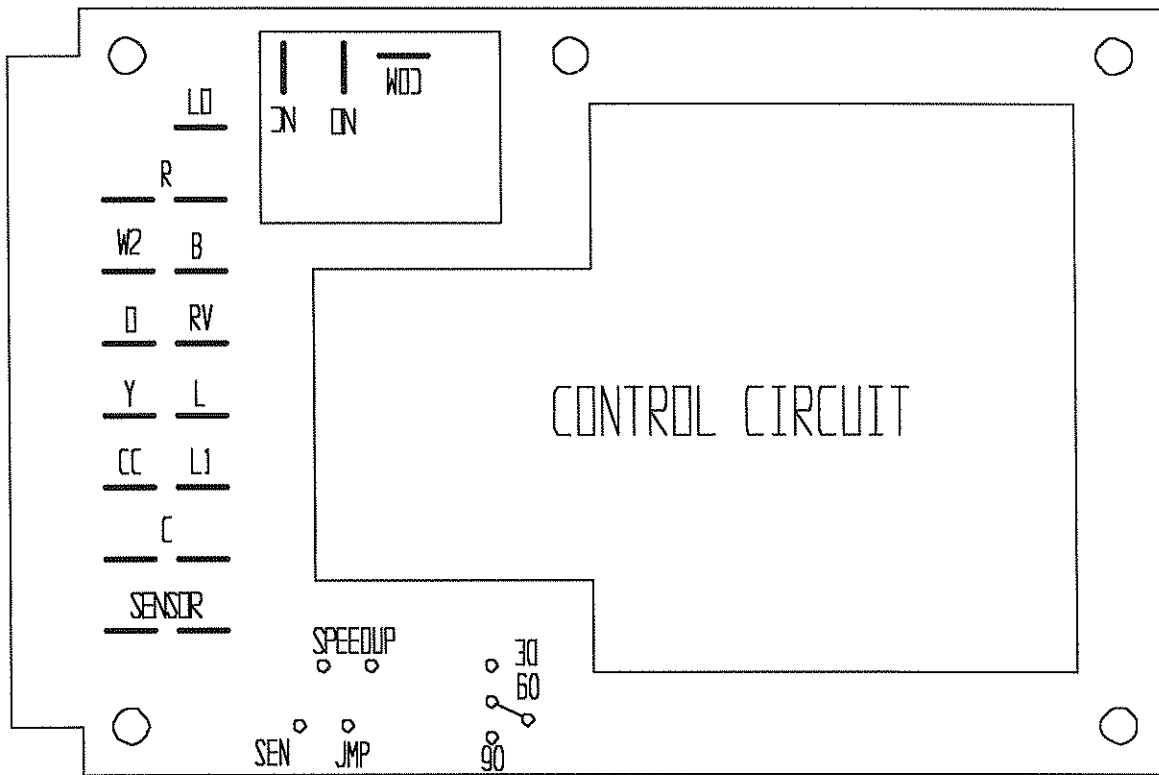
There is an initiate defrost jumper (sen jump) on the control that can be used at any outdoor ambient during the heating cycle to simulate a 0° coil temperature. This can be used to check defrost operation of the unit without waiting for the outdoor ambient to fall into the defrost region.

By placing a jumper across the *SEN JMP* terminals (a 1/4 inch QC terminal works best) the defrost sensor mounted on the outdoor coil is shunted out and will activate the timing circuit. This permits the defrost cycle to be checked out in warmer weather conditions without the outdoor temperature having to fall into the defrost region.

In order to terminate the defrost test the *SEN JMP* jumper must be removed. If left in place too long the compressor could stop due to the high pressure control opening because of high pressure condition created by operating in the cooling mode with outdoor fan off. Pressure will rise fairly fast as there is likely no actual frost on the outdoor coil in this artificial test condition.

There is also a 5 minute compressor time delay function built into the HPC. This is to protect the compressor from short cycling conditions. In some instances it is helpful to the service technician to override or speed up this timing period, and shorting out the *SPEEDUP* terminals for a few seconds can do this.

**FIGURE 10
DEFROST CONTROL BOARD**



MIS-1174

TROUBLESHOOTING

SOLID STATE HEAT PUMP CONTROL TROUBLESHOOTING PROCEDURE

1. Turn on AC power supply to indoor and outdoor units.
2. Turn thermostat blower switch to “fan on” – the indoor blower should start. (If it doesn’t, troubleshoot indoor unit and correct problem.)

3. Turn thermostat blower switch to “auto” position. Indoor blower should stop (after time delay).
4. Set system switch to “heat” or “cool”. Adjust thermostat to call for heat or cool – the indoor blower, compressor and outdoor fan should start.

NOTE: If there was no power to 24 volt transformer, the compressor and outdoor fan motor will not start for 5 minutes. This is because of the compressor short cycle protection.

**TABLE 5
TROUBLESHOOTING**

SYMPTOM	POSSIBLE CAUSES	WHAT TO CHECK	HOW TO CHECK OR REPAIR
Compressor contactor does not energize (cooling or heating)	Control circuit wiring	Check for R connection at unit, and 24V between R-C	Run R connection to outdoor unit to power heat pump control
	Compressor lock out	1. Check for 24V between L1-C on heat pump control 2. Check across high	1. If no voltage between L-C turn thermostat off and on again to reset high pressure switch. 2. If high pressure switch is open and will not
	Compressor short cycle protection	Check for 24V between CC-C and Y-C on heat pump control	If no voltage between CC-C, jumper speed up terminal and within 10 seconds power should appear between CC-C. Remove speed up jumper after 10 seconds.
	Heat pump control defective	Check all other possible causes. Manual 2100-065	Replace heat pump control
	Contactor defective	Check for open or shorted coil winding.	Replace contactor
Fan outdoor motor does not run (cooling or heating except during defrost)	Motor defective	Check for open or shorted motor winding	Replace motor
	Motor capacitor defective	Check capacitor rating. Check for open or shorted capacitor.	Replace capacitor
	Heat pump control defective	Check across fan relay on heat pump control (Com-NC)	Replace heat pump control
Reversing valve does not energize (heating only)	Reversing valve solenoid coil defective	Check for open or shorted coil	Replace solenoid coil
	Heat pump control defective	Check for 24V between RV-C and B-C	1. Check control circuit wiring 2. Replace heat pump control
Unit will not go into defrost (heating only)	Temperature sensor or heat pump control defective	Disconnect temperature sensor from board and jumper across speed up terminals and sen jump terminals. This should cause the unit to go through a defrost cycle within one minute.	1. If unit goes through defrost cycle, replace temperature sensor 2. If unit does not go through defrost cycle, replace heat pump control
Unit will not come out of defrost (heating only)	Temperature sensor or heat pump control defective	Jumper across speed up terminals. This should cause the unit to come out of defrost within one minute.	1. If unit comes out of defrost cycle, replace temperature sensor. 2. If unit does not come out of defrost cycle, replace heat pump control.

CHECKING TEMPERATURE SENSOR OUTSIDE UNIT CIRCUIT.

1. Disconnect temperature sensor from outdoor coil.
2. Use an ohmmeter and measure the resistance of the sensor. Also use ohmmeter to check for short or open.
3. Check resistance reading to chart of resistance use ambient temperature. (Tolerance of part is $\pm 10\%$.)
4. If sensor resistance reads very low, then sensor is shorted and will not allow proper operation of the heat pump control.
5. If sensor is out of tolerance, shorted, open or reads very low ohms then it should be replaced

TEMPERATURE F VS RESISTANCE R OF TEMPERATURE SENSOR

F	R	F	R	F	R
-25.0	196871	25.0	39898	75.0	10501
-24.0	190099	26.0	38757	76.0	10247
-23.0	183585	27.0	37652	77.0	10000
-22.0	177318	28.0	36583	78.0	9760
-21.0	171289	29.0	35548	79.0	9526
-20.0	165487	30.0	34545	80.0	9299
-19.0	159904	31.0	33574	81.0	9077
-18.0	154529	32.0	32634	82.0	8862
-17.0	149355	33.0	31723	83.0	8653
-16.0	144374	34.0	30840	84.0	8449
-15.0	139576	35.0	29986	85.0	8250
-14.0	134956	36.0	29157	86.0	8057
-13.0	130506	37.0	28355	87.0	7869
-12.0	126219	38.0	27577	88.0	7686
-11.0	122089	39.0	26823	89.0	7507
-10.0	118108	40.0	26092	90.0	7334
-9.0	114272	41.0	25383	91.0	7165
-8.0	110575	42.0	24696	92.0	7000
-7.0	107010	43.0	24030	93.0	6840
-6.0	103574	44.0	23384	94.0	6683
-5.0	100260	45.0	22758	95.0	6531
-4.0	97064	46.0	22150	96.0	6383
-3.0	93981	47.0	21561	97.0	6239
-2.0	91008	48.0	20989	98.0	6098
-1.0	88139	49.0	20435	99.0	5961
0.0	85371	50.0	19896	100.0	5827
1.0	82699	51.0	19374	101.0	5697
2.0	80121	52.0	18867	102.0	5570
3.0	77632	53.0	18375	103.0	5446
4.0	75230	54.0	17898	104.0	5326
5.0	72910	55.0	17434	105.0	5208
6.0	70670	56.0	16984	106.0	5094
7.0	68507	57.0	16547	107.0	4982
8.0	66418	58.0	16122	108.0	4873
9.0	64399	59.0	15710	109.0	4767
10.0	62449	60.0	15310	110.0	4663
11.0	60565	61.0	14921	111.0	4562
12.0	58745	62.0	14544	112.0	4464
13.0	56985	63.0	14177	113.0	4367
14.0	55284	64.0	13820	114.0	4274
15.0	53640	65.0	13474	115.0	4182
16.0	52051	66.0	13137	116.0	4093
17.0	50514	67.0	12810	117.0	4006
18.0	49028	68.0	12492	118.0	3921
19.0	47590	69.0	12183	119.0	3838
20.0	46200	70.0	11883	120.0	3757
21.0	44855	71.0	11591	121.0	3678
22.0	43554	72.0	11307	122.0	3601
23.0	42295	73.0	11031	123.0	3526
24.0	41077	74.0	10762	124.0	3452

FAN BLADE SETTING DIMENSIONS

Shown in the drawing below are the correct fan blade setting dimensions for proper air delivery across the outdoor coil.

Any service work requiring removal or adjustment in the fan and/or motor area will require that the dimensions below be check and blade adjusted in or out on the motor shaft accordingly.

FIGURE 11

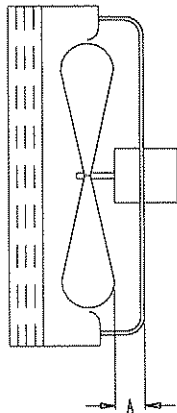


TABLE 6

Model	Dimension A
WH242D	1.00

MIS-1190

REMOVAL OF THE FAN SHROUD

1. Disconnect all power to unit.
2. Remove the screws holding both grilles, one on each side of unit, and remove grilles.
3. Remove screws (9) holding fan shroud to condenser and bottom.
4. Unwire condenser fan motor.
5. Slide complete motor, fan blade, and shroud assembly out the left side of the unit.
6. Service motor/fan as needed.
7. Reverse steps to reinstall.

REFRIGERANT CHARGE

The correct system R-22 charge is shown on the unit rating plate. Optimum unit performance will occur with a refrigerant charge resulting in a suction line temperature (6" from compressor) as shown in Table 7.

The suction line temperatures shown in Table 7 are based upon 80° F dry bulb / 67° F wet bulb (50% R.H.) temperature and rated airflow across the evaporator during cooling cycle.

TABLE 7
SUCTION LINE TEMPERATURES

(Temperatures °F)

Model	Rated Airflow	95° OD Temperature	82° OD Temperature
WH242D	800	57 - 59	65 - 67

TABLE 8
INDOOR BLOWER PERFORMANCE
CFM @ 230V

E.S.P. In H ₂ O	WH242D	
	Dry	Wet
.0	1020	975
.1	960	905
.2	865	800
.3	820	735
.4	735	650
.5	615	535
.6	---	---

TABLE 9
RATED CFM AND ESP

Model	Rated CFM *	Rated ESP *	Recommended Airflow Range
WH242D	800	.20	700 --- 950

* Rated CFM and ESP on high speed tap.

TABLE 10
MAXIMUM ESP OF OPERATION

Model	ESP	
WH242D	A00	.50
	A04	.50
	A08	.40
WH242D	B00	.50
	B06	.50
WH242D	C00	.50
	C06	.50

Values shown are for units equipped with standard throwaway filter or 1" washable filter. Derate ESP by .15 for 2" pleated filter.

**TABLE 11
PRESSURE TABLE**

COOLING

Air Temperature Entering Outdoor Coil °F

Model	Return Air Temperature	Pressure	75	80	85	90	95	100	105	110	115
WH242D	75 deg. DB 62 deg. WB	Low Side	75	76	77	79	80	81	83	84	86
		High Side	216	229	242	256	271	286	302	318	336
	80 deg. DB 67 deg. WB	Low Side	80	81	83	84	85	87	88	90	92
		High Side	221	235	248	263	278	293	310	327	344
	85 deg. DB 72 deg. WB	Low Side	86	88	89	90	92	93	95	97	99
		High Side	229	243	257	272	288	304	321	338	356

Pressures in dehumidification mode will be slightly less than normal cooling mode.

**TABLE 12
PRESSURE TABLE**

HEATING

Air Temperature Entering Outdoor Coil °F

Model	Return Air Temperature	Pressure	0	5	10	15	17	20	25	30	35	40	45	47	50	55	60
WH242D	70 deg.	Low Side	30	30	31	32	33	34	37	41	45	50	56	59	63	71	79
		High Side	158	158	159	162	164	167	175	184	195	208	223	230	241	260	281

Low Side Pressure ± 2 PSIG

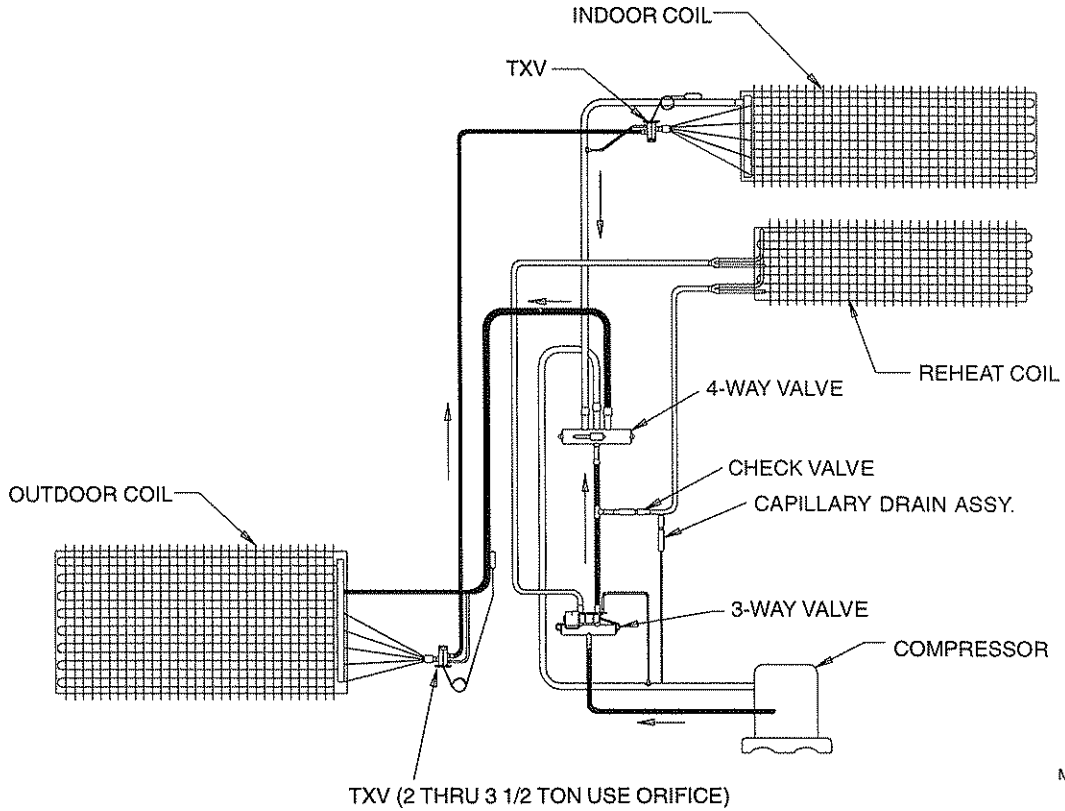
High Side Pressure ± 5 PSIG

Tables are based upon rated CFM (airflow) across the evaporator coil and should be found under section titled "Refrigerant Charge" elsewhere in manual. If there is any doubt as to correct operation charge being in the system, the charge should be removed, system evacuated, and recharged to serial plate instructions.

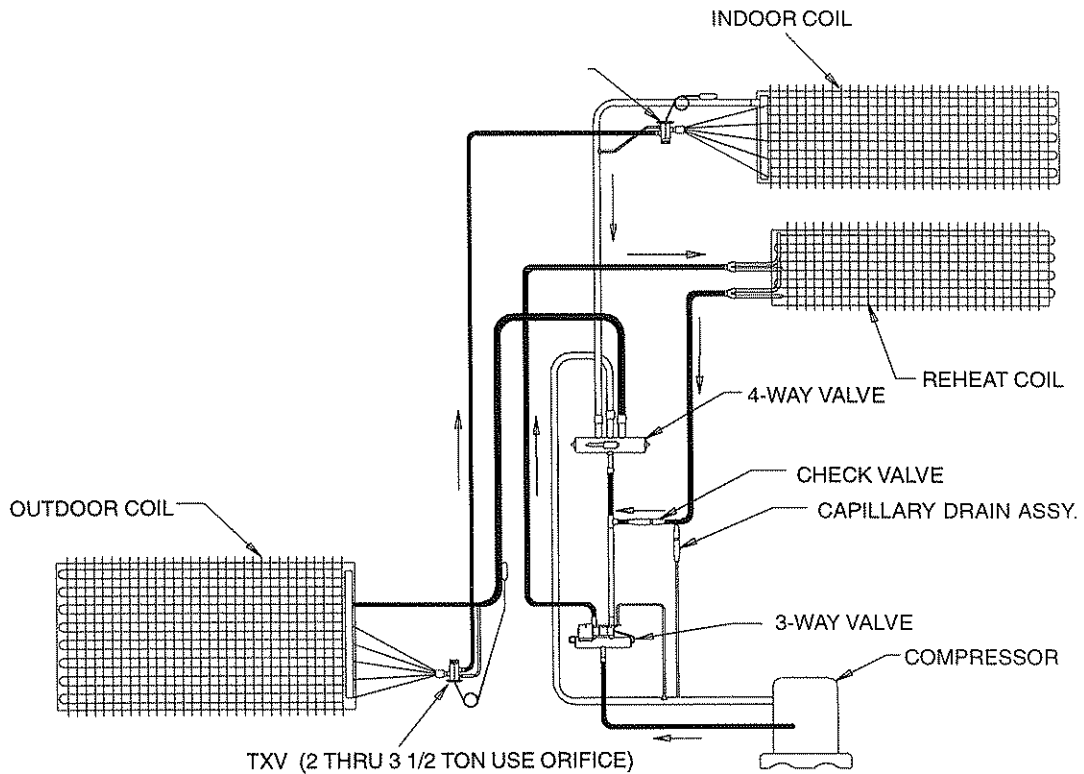
**TABLE 13
OPTIONAL ACCESSORIES**

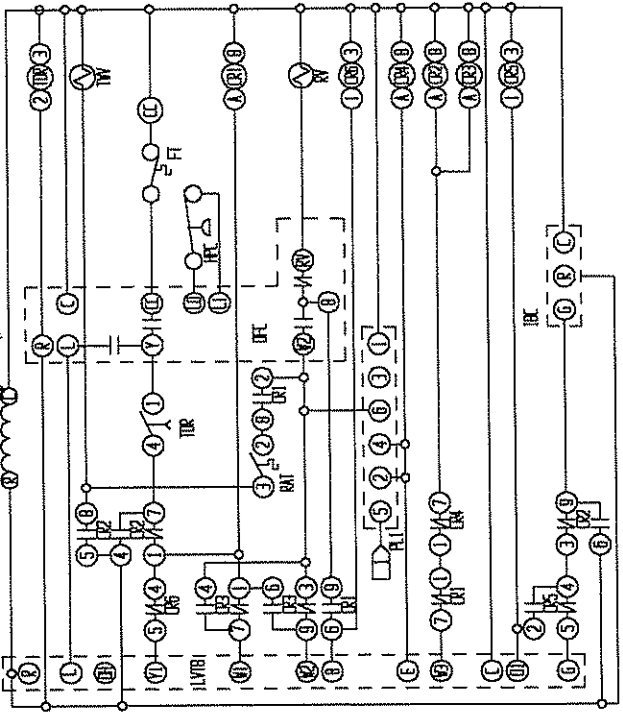
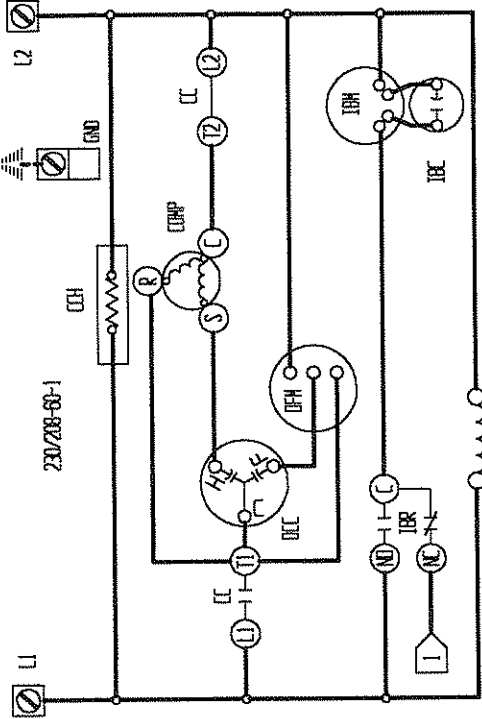
Model	Description	WH242DA	WH242DB	WH242DC
EHWH02A-A04	Heater Packages	X		
EHWH02A-A08	Heater Packages	X		
EHWH24-B06	Heater Packages		X	
EHWH24B-C06	Heater Packages			X
BOP-2	Blank Off Plate			
BFAD-2	Barometric Fresh Air Damper			X
MFAD-2	Motorized Fresh Air Damper	X		X
CRV-2	Classroom Ventilator with Exhaust	X		X
EIFM-2	Economizer with Exhaust	X		X
WERV-A2A	Energy Recovery Ventilator	X	X	
CMH-3	Low Pressure Control (LPC)	X	X	X
CMH-7	Low Ambient Control (LAC)	X	X	
CMH-9	LAC + LPC	X	X	
CMH-15	Start Kit (SK)	X		
WMCB-03A	Circuit Breaker Kit	X		
WMBC-02B	Circuit Breaker Kit		X	
WMBC-01C	Pull Disconnect Kit			X

**FIGURE 12
BARD MFG. HEAT PUMP COOLING MODE
CIRCUIT DIAGRAM**

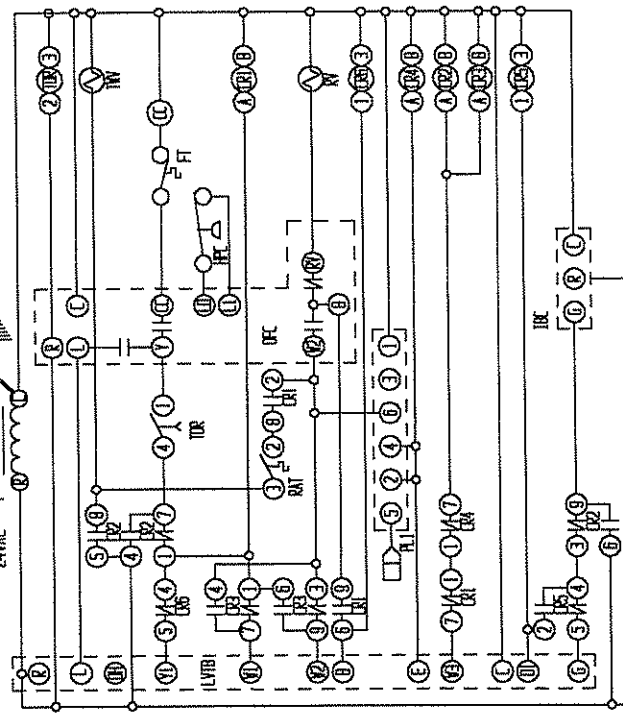
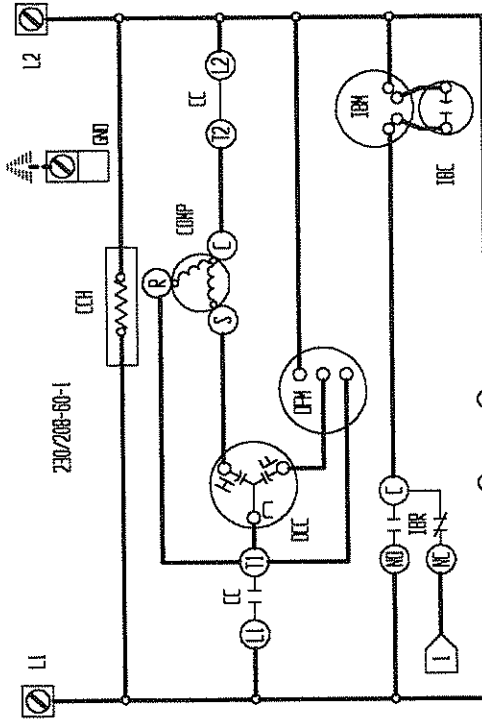


**FIGURE 13
BARD MFG. HEAT PUMP DEHUMIDIFICATION MODE
CIRCUIT DIAGRAM**



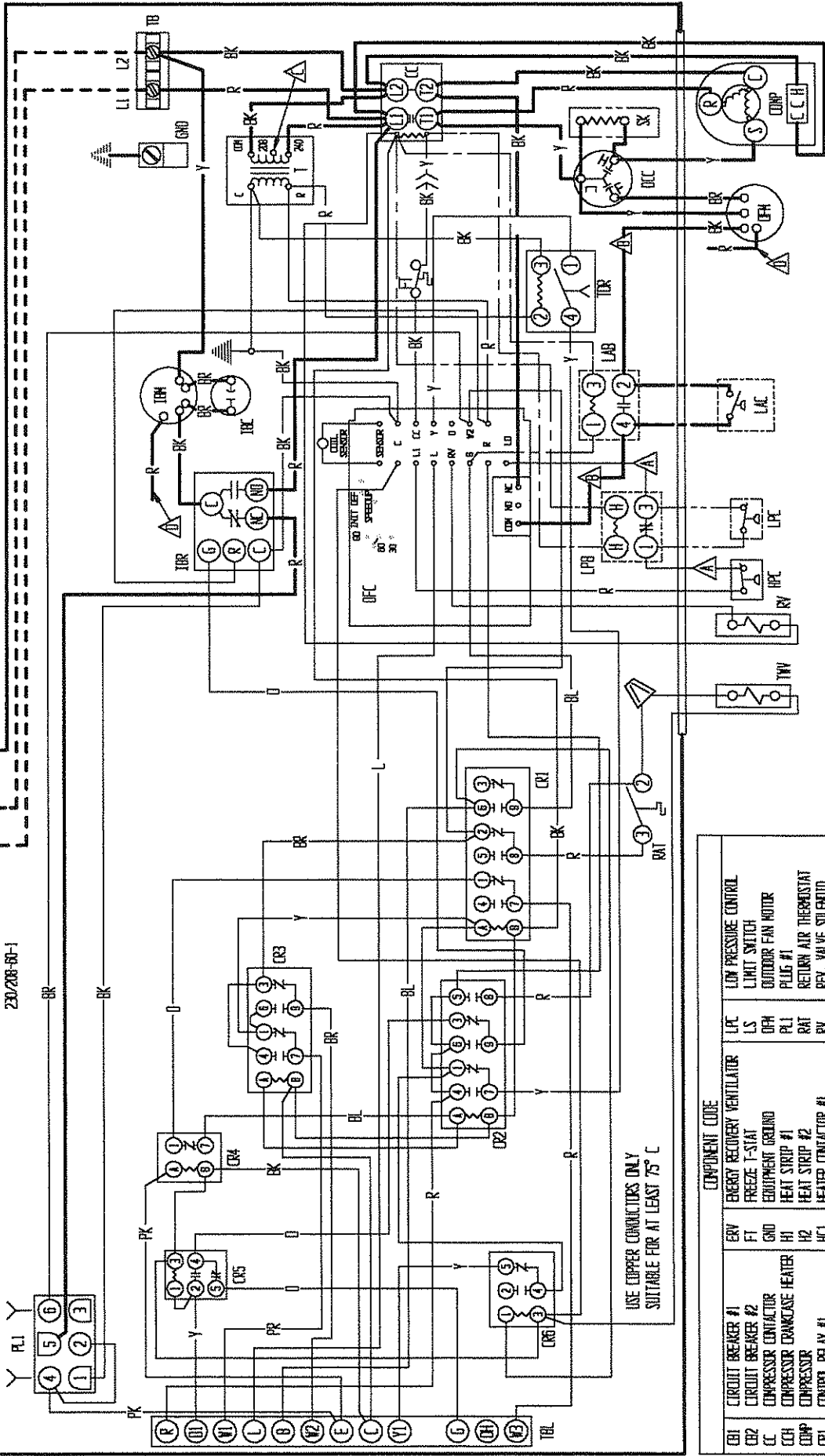


4096-120 B



4096-120 B

230/208-60-1



RED (LOW) BLACK (HIGH) WHERE APPLICABLE

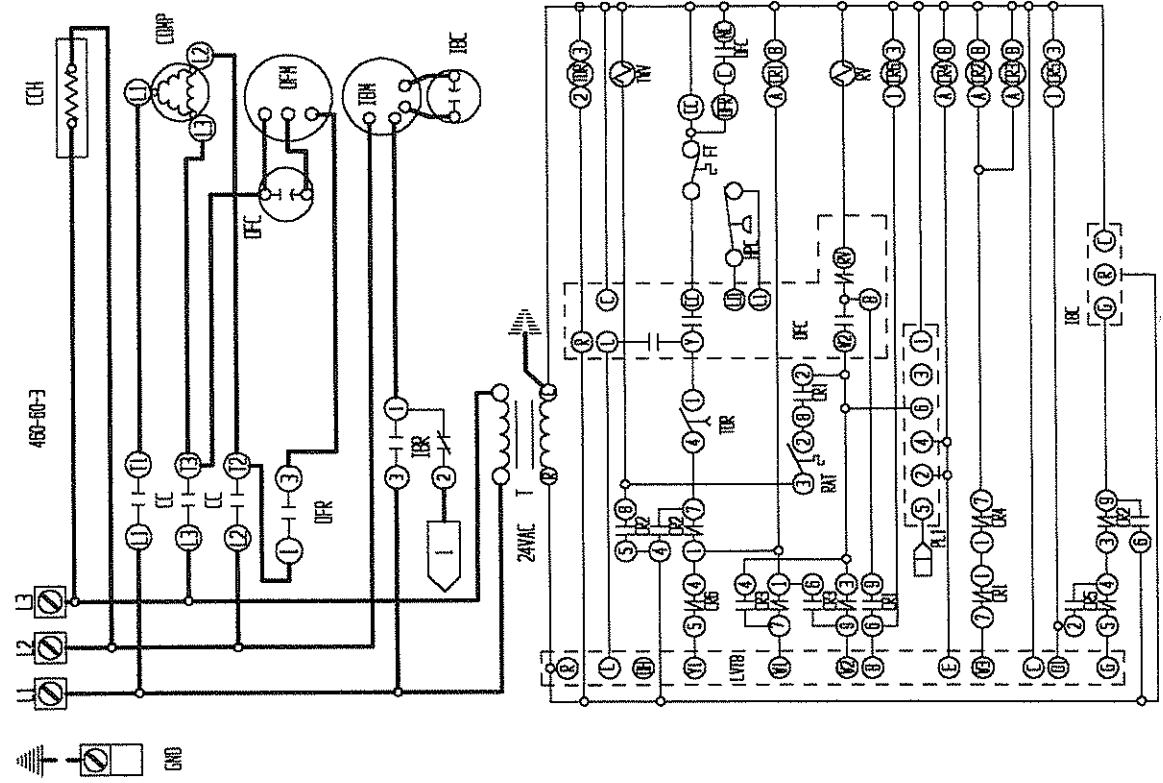
△ WIRE RED WIRE TO 208V TAP FOR 208V OPERATION △ WHERE APPLICABLE

FACTORY STD.	FIELD	OPTIONAL	COLOR CODE	T	PK	L
BLACK	BR	Y	BLACK	VIOLET	PURPLE	GRAY
BROWN	BR	G	BROWN	GREEN (PR)	BLUE	SLATE
RED	R	BL	RED	WHITE	WHITE	SLATE
DRANCE	U	Y	DRANCE	WHITE	WHITE	SLATE

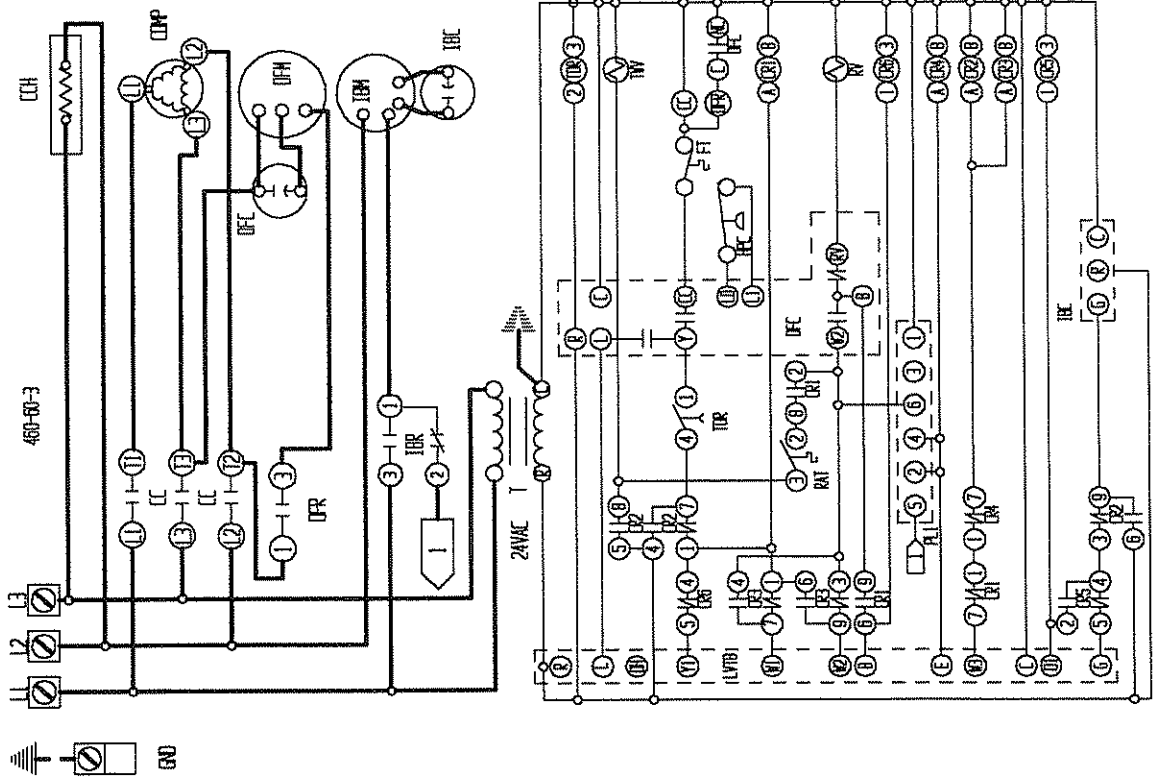
BARB MFG. CO. 4096-123 C

COMPONENT CODE	
CB1	CIRCUIT BREAKER #1
CB2	CIRCUIT BREAKER #2
CC	COMPRESSOR CONTACTOR
CC1	COMPRESSOR CONTACTOR #1
CC2	COMPRESSOR CONTACTOR #2
CR1	CONTROL RELAY #1
CR2	CONTROL RELAY #2
CR3	CONTROL RELAY #3
CR4	CONTROL RELAY #4
CR5	CONTROL RELAY #5
CR6	CONTROL RELAY #6
DCC	DUAL CAN CAPACITOR
DPC	DEFROST CONTROL
ERV	ENERGY RECOVERY VENTILATOR
FT	FREIZE T-STAT
GRD	EQUIPMENT GROUND
H1	HEAT STRIP #1
H2	HEAT STRIP #2
H1C	HEATER CONTACTOR #1
H2C	HEATER CONTACTOR #2
HPC	HIGH PRESSURE CONTROL
IBC	INDOOR BLOWER CAPACITOR
IBM	INDOOR BLOWER MOTOR
IBR	INDOOR BLOWER RELAY
LAB	LOW AMBIENT BYPASS CONTROL
LAC	LOW AMBIENT CONTROL
LPB	LOW PRESSURE BYPASS
LPC	LOW PRESSURE CONTROL
LS	LIMIT SWITCH
OFM	OUTDOOR FAN MOTOR
PL1	PLUS #1
RAT	RETURN AIR THERMOSTAT
RV	REV. VALVE SOLENOID
SK	START KIT
T	TRANSFORMER
TB	TERMINAL BLOCK
TBL	LOW VOLTAGE TERMINAL BLOCK
TCD	THERMAL CUTOFF
TWV	THREE WAY VALVE
TIR	TIME RELAY RELAY

USE COPPER CONDUCTORS ONLY SUITABLE FOR AT LEAST 75 °C



4096-321 B



4096-321 B

