

---

# INSTALLATION INSTRUCTIONS

---

## ECONOMIZERS WITH EXHAUST

MODEL  
**WGEIFM-3B**  
**WGEIFM-5B**

**For Use with Bard 2 thru 5 Ton  
Wall Mount Gas Electric Models**



CLIMATE CONTROL SOLUTIONS

Bard Manufacturing Company  
Bryan, Ohio 43506

*Since 1914...Moving ahead, just as planned.*

Manual : 2100-378B  
Supersedes: 2100-378A  
File: Volume III Tab 19  
Date: 01-18-02

# CONTENTS

---

## GENERAL

General Information .....	1
Unpacking .....	1
Description .....	1

## INSTALLATION

Basic Installation .....	2
Economizer Sequence of Operation .....	6
Wall Thermostats .....	8
Wiring Diagram .....	16

## FIGURES

Figure 1 Installation of Economizer .....	2
Figure 2 Installation of Economizer .....	3
Figure 3 Economizer Logic Module .....	4
Figure 4 Economizer Operation .....	6
Figure 5 Mechanical Cooling Operation .....	7
Figure 6 Economizer Operation for Single Compressor Unit .....	8
Figure 7 Low Voltage Wiring .....	15

## TABLES

Table 1 Economizer Logic Control Setting .....	5
Table 2 Ventilation Air Table .....	9
Table 3A Ventilation Air Table .....	10
Table 3B Ventilation Air Table .....	10
Table 3C Ventilation Air Table .....	11
Table 3D Ventilation Air Table .....	11
Table 4 Ventilation Air Table .....	12
Table 5A Ventilation Air Table .....	13
Table 5B Ventilation Air Table .....	13
Table 5C Ventilation Air Table .....	14

Manufactured under U.S. patent number 5,301,744.  
Other patents pending.

COPYRIGHT JANUARY 2002  
BARD MANUFACTURING COMPANY  
BRYAN, OHIO USA 43506

## GENERAL INFORMATION

The economizer should only be installed by a trained heating and air conditioning technician. These instructions serve as a guide to the technician installing the economizer package. They are not intended as a step by step procedure with which the mechanically inclined owner can install the package.

The economizer housing is shipped in one carton which contains the electrical harness, miscellaneous hardware and installation instructions.

The economizer installation requires an additional two stage cooling thermostat in place of the normal single stage cooling thermostat.

If using a Bard master controller, the MC91AE master controller is designed specifically to control two (2) redundant Bard wall mount units equipped with economizers.

Any wall mount unit equipped with an economizer must also have a low ambient control installed. This control can be factory installed or field installed. If field installed, use kit CMA-6.

## UNPACKING

Upon receipt of the equipment be sure to compare the model number found on the shipping label with the accessory identification information on the orders and shipping document to verify that the correct accessory has been shipped.

Inspect the carton housing of each economizer as it is received, and before signing the freight bill, verify that all items have been received and that there is no visible damage. Note any shortages or damage on all copies of the freight bill. The receiving party must contact the last carrier immediately, preferably in writing, requesting inspection by the carrier's agent. Concealed damage not discovered until after loading must be reported to the carrier within 15 days of its receipt.

## DESCRIPTION

The economizer is designed to be used with Bard 2 through 5 ton wall mount series gas electric models equipped with low ambient fan cycling controls. They are electromechanical economizer systems designed to provide "free" cooling where the outdoor air temperature is cool enough to provide the needed cooling without running the compressor. When cooling is needed, the system automatically takes advantage of cold outdoor air when available and uses it for first stage cooling. This then reduces the need to run the air conditioning compressor providing lower operating costs and increasing the service life of the equipment. If the outdoor air gets too warm or humid to be helpful, the enthalpy control detects the condition and automatically closes the outdoor air and exhaust damper, opens the return air damper and switches to the compressor operation. This is all done automatically to achieve maximum savings without attention from the user. See Figure 6 for a block diagram of the economizer operation logic flow. The unit is equipped with a full modulating type damper motor which controls the damper position to a factory set minimum supply air temperature.

# INSTALLATION

## BASIC INSTALLATION

1. Unpack the economizer assembly which includes the integral economizer with attached electrical harness, mixed air thermistor, miscellaneous hardware and installation instructions.

### **WARNING**

Open and lock unit disconnect switch before installing this accessory to prevent injury or death due to electrical shock or contact with moving parts. Turn thermostat to off.

2. Remove and save existing unit return air filter and center screw in front grille. (See Figure 1.)
3. Remove and discard the front exhaust cover plate. (See Figure 1.)
4. Install economizer by inserting the economizer into the unit. (See Figure 2.)

*IMPORTANT: Position front lip of economizer on top of front grille and condenser partition (See Figure 2 inset.) This is important to ensure proper drainage of any water entering damper assembly.*

**FIGURE 1  
INSTALLATION OF ECONOMIZER**

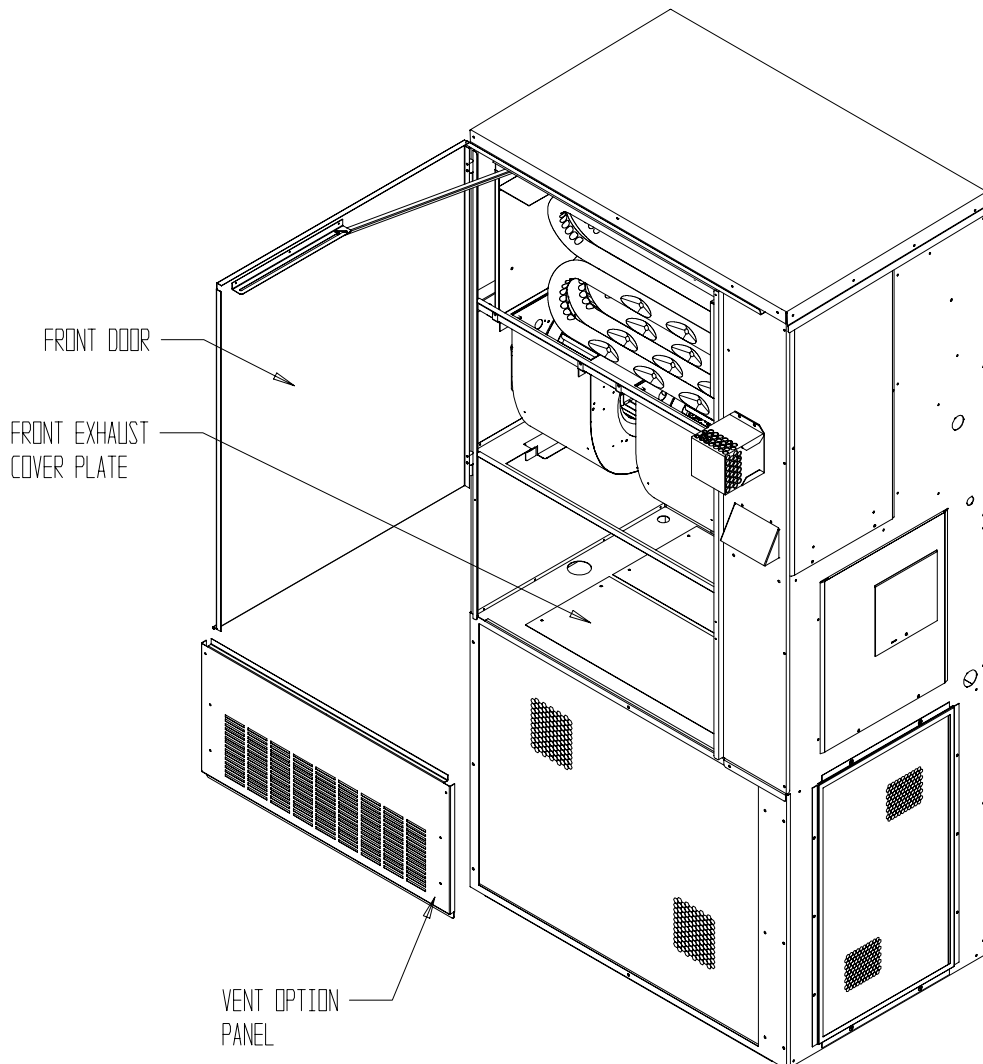

MIS-1678

5. Mount mixed air thermistor to blower as shown with screws provided. Route wires as shown and secure with wire tie. Connect wires to thermistor.
6. Open unit control panel to gain access to unit low voltage terminal block.
7. Route electrical harness leads through the 7/8" bushing in control panel (Figure 2) into low voltage box.
8. Connect leads with fork terminal to corresponding points on terminal strip. (See wiring diagram.)
9. Close control panel cover
10. Reinstall the blower access panel at top of unit and secure with sheet metal screws.
11. Replace filter and screws in front condenser grille.

**FIGURE 2  
INSTALLATION OF ECONOMIZER**

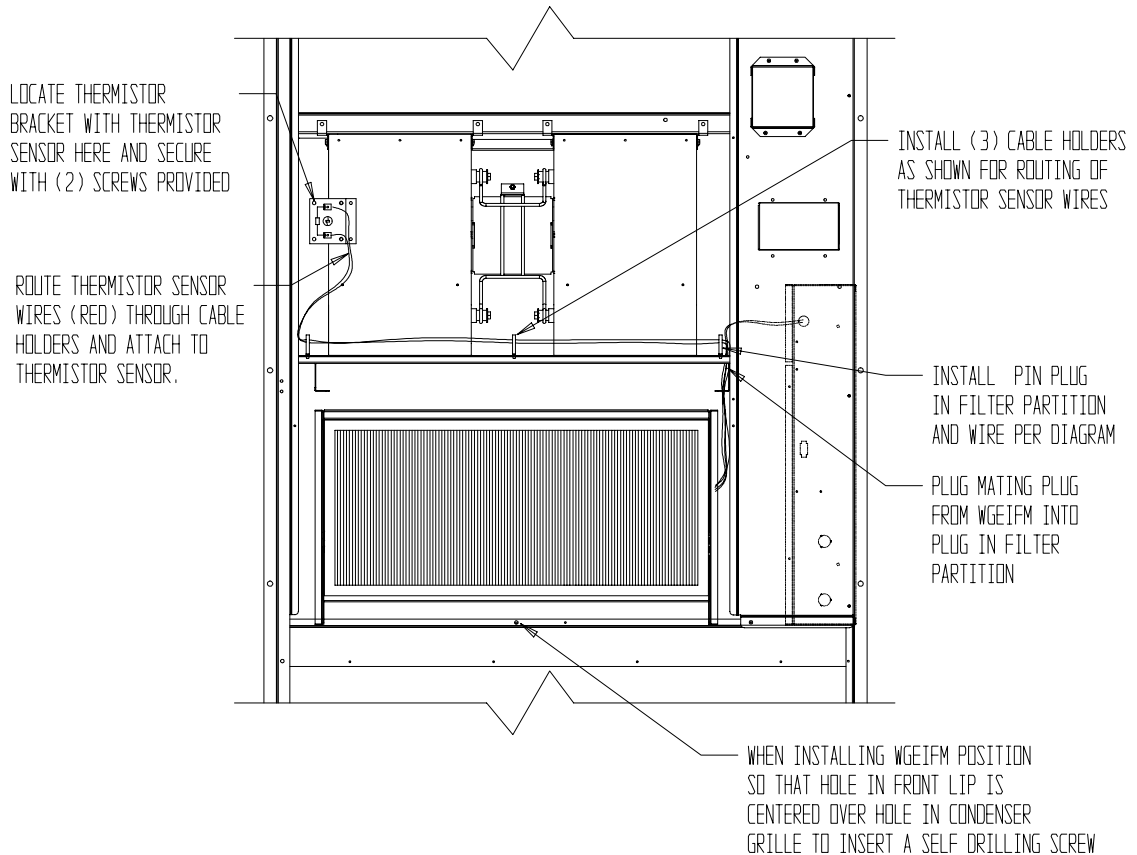

**INSET**

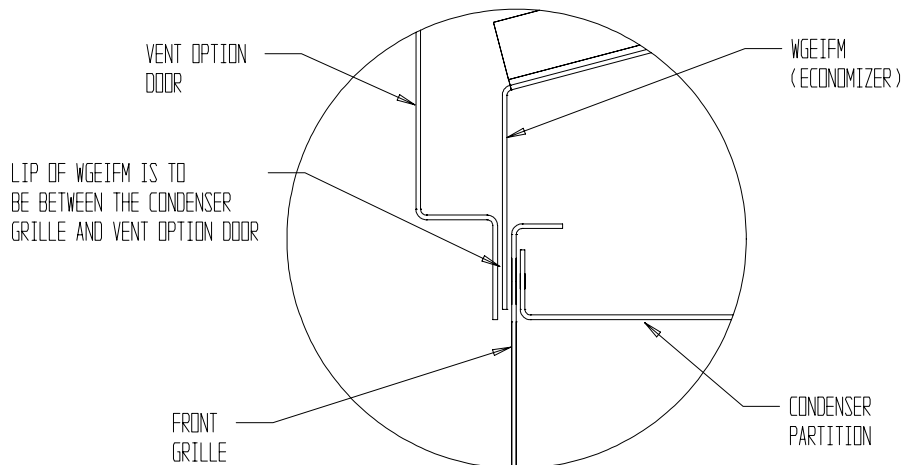

**FIGURE 3  
ECONOMIZER LOGIC MODULE**

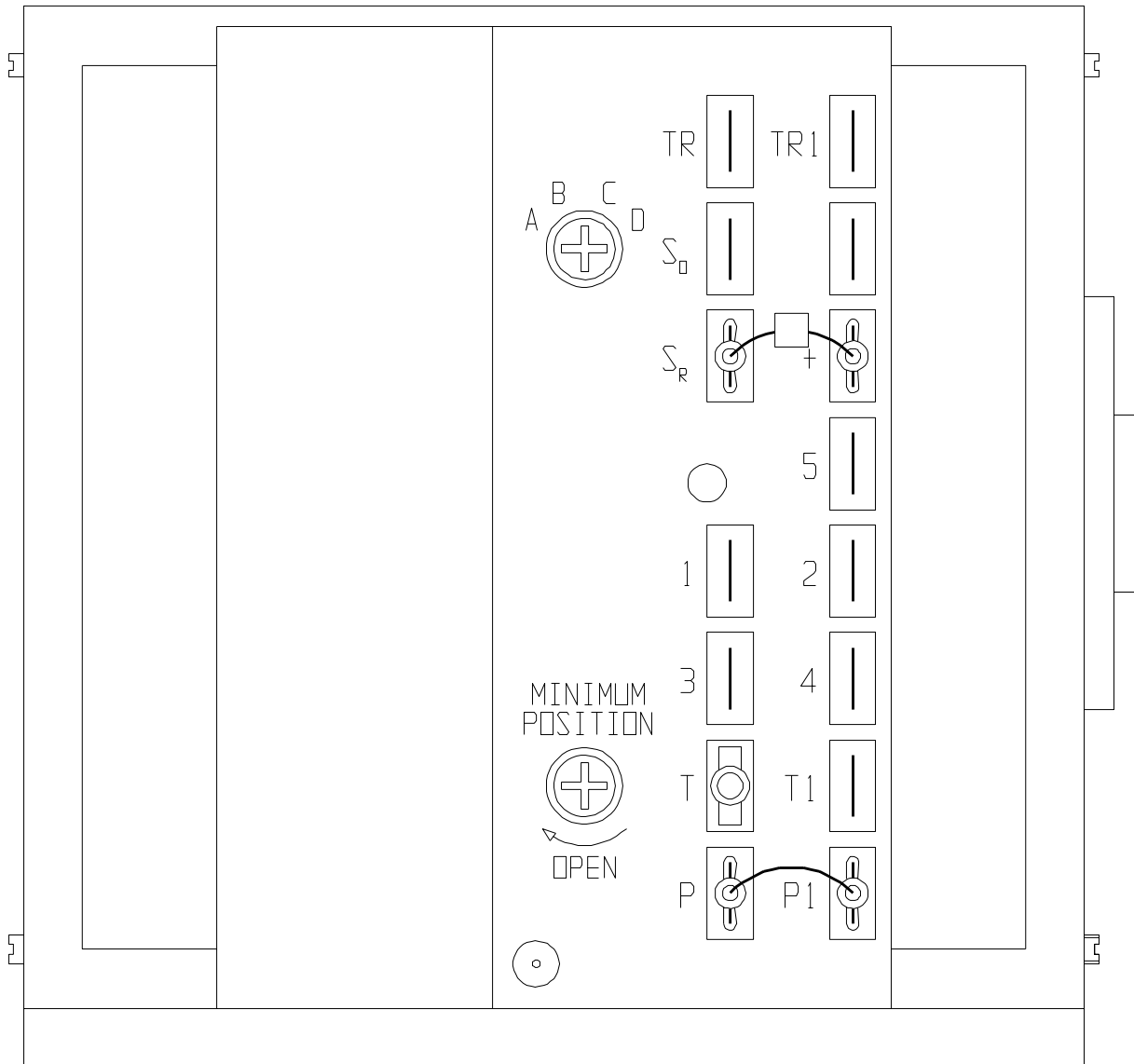

MIS-1146

## 12. ECONOMIZER CHECK OUT

- A. Remove mist eliminator (Figure 2). Locate the minimum position potentiometer. (See Figure 3.)
- B. Energize the evaporator blower by switching thermostat to the manual fan position with heat/cool in the OFF position.
- C. Cycle the minimum position potentiometer (factory set for 0% fresh air) 0 to full open. (See Figure 3.) Throughout checkout procedure observe operation of damper to insure there is free, unobstructed operation through the entire angle of damper travel. Then adjust the damper minimum open position to meet local codes or application requirements. See example below.

### EXAMPLE:

1. Measure return air temperature (RAT) (assume 75° F for example).
2. Measure outdoor air temperature (OAT) (assume 60° F for example).
3. Calculate the mixed air temperature (MAT) which will result from the desired combination of OAT (10 percent) and RAT (90 percent).

$$.1 \text{ OAT} + .9 \text{ RAT} = \text{MAT}$$

or substituting example values

$$.1 (60^\circ \text{ F}) + .9 (75^\circ \text{ F}) = 73.75^\circ \text{ F}$$

4. Adjust the minimum position potentiometer knob until proper mixed air temperature as calculated above is reached. Care should be taken to insure thermometer is sensing air that is well mixed.
  5. Mark correct setting on dial of minimum position potentiometer for future reference.
- D. Adjust the economizer logic module to position A, B, C and D to achieve the maximum combination of temperature and humidity acceptable for the installation as per Table 1. The suggested setting is between A & B 70° DB @ 55 percent RH. It is further recommended to always set the control at C or above.) (See Figure 3.)

- E. Switch the thermostat fan control to automatic and position the heat/cool switch to cool. Adjust the thermostat temperature to engage the first stage of cooling only (Y). This will cause the dampers to modulate to achieve mixed air temperature of 55° provided outside air enthalpy is sufficiently low. If enthalpy is too high for economizing, low enthalpy can be simulated by temporarily removing and jumping leads on terminals 2 and 3 of enthalpy control together. This will also cause the economizer damper to modulate away from minimum position. (*Be sure to properly reconnect leads at end of checkout procedure*).
- F. Readjust temperature on the thermostat to engage the second stage of cooling (Y2). The damper motor should return to previously set minimum position. Compressor motor should start.
- G. Switch thermostat to OFF fan and OFF heat/cool positions to de-energize unit. Economizer damper should return to full closed (100 percent return air) position. Checkout is complete.

13. Replace control access panel and mist eliminator.
14. Remove blank off plate or barometric fresh air damper if installed on the service access panel. Plug the four (4) holes used to mount the BOP or BFAD with the plastic plugs supplied with the economizer.
15. Replace service access panel.
16. Economizer is now ready for operation.

**TABLE 1  
ECONOMIZER LOGIC CONTROL SETTING**

	Dial Setting	20% RH	50% RH	80% RH
<b>Economizer Logic Module Setting</b>	A	79 deg. F (26 deg. C)	72 deg. F (22 deg. C)	65 deg. F (18 deg. C)
	B	77 deg. F (25 deg. C)	69 deg. F (20 deg. C)	62 deg. F (16 deg. C)
	C	74 deg. F (23 deg. C)	66 deg. F (18 deg. C)	58 deg. F (14 deg. C)
	D	71 deg. F (21 deg. C)	63 deg. F (17 deg. C)	54 deg. F (12 deg. C)

## ECONOMIZER SEQUENCE OF OPERATION

### CONDITION A – COOL OUTDOORS

First stage cooling closes and powers the economizer dampers to economizer mode and the indoor blower starts. Mixed Air Sensor senses a mixture of return

air and outdoor air and modulates the dampers accordingly. Compressor operation is inhibited. (See Figure 4.)

If second stage closes on the thermostat, the dampers return to the closed or minimum position setting and the compressor starts for mechanical cooling.

**FIGURE 4  
ECONOMIZER OPERATION**

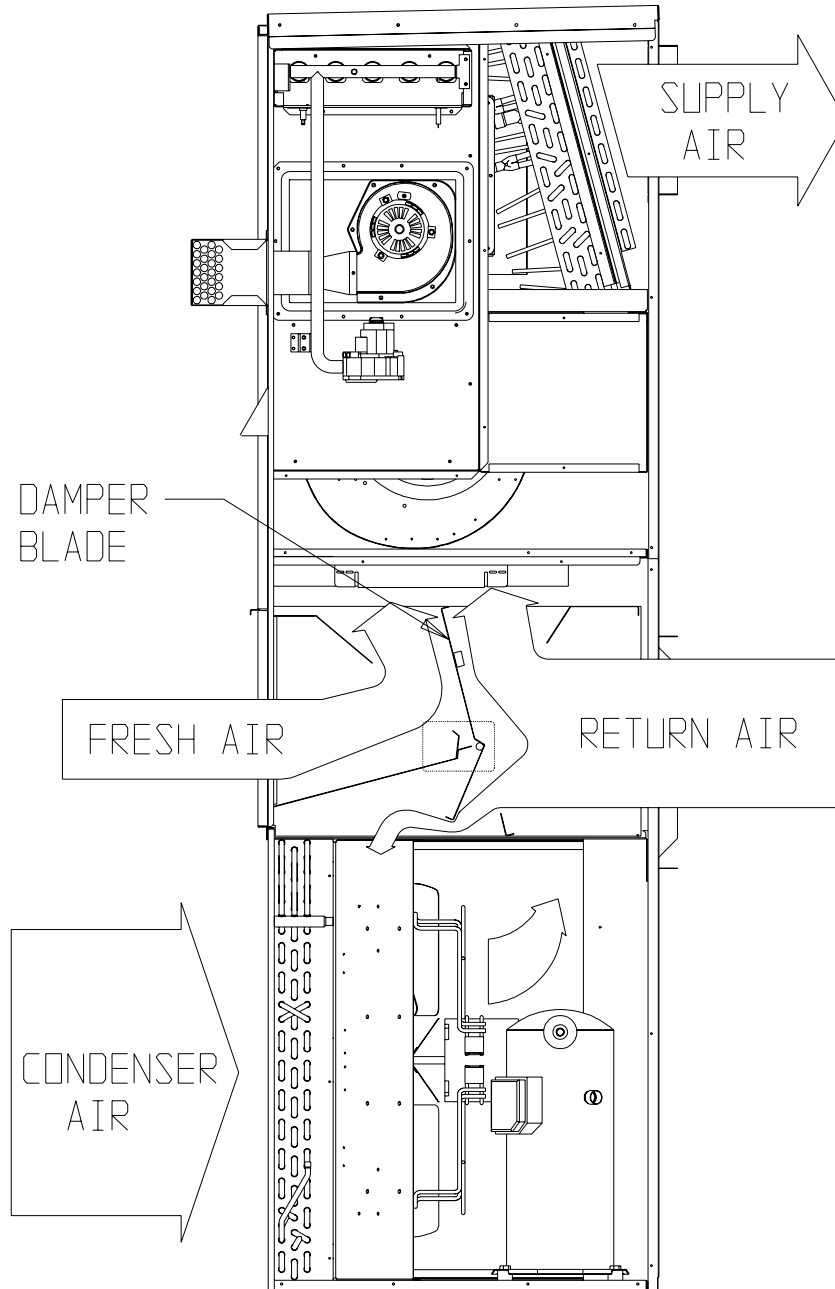

MIS-1465



**CONDITION B – WARM OUTDOORS**

First stage cooling cycles the compressor and dampers remain in mechanical cooling mode.

**FIGURE 5  
MECHANICAL COOLING OPERATION**

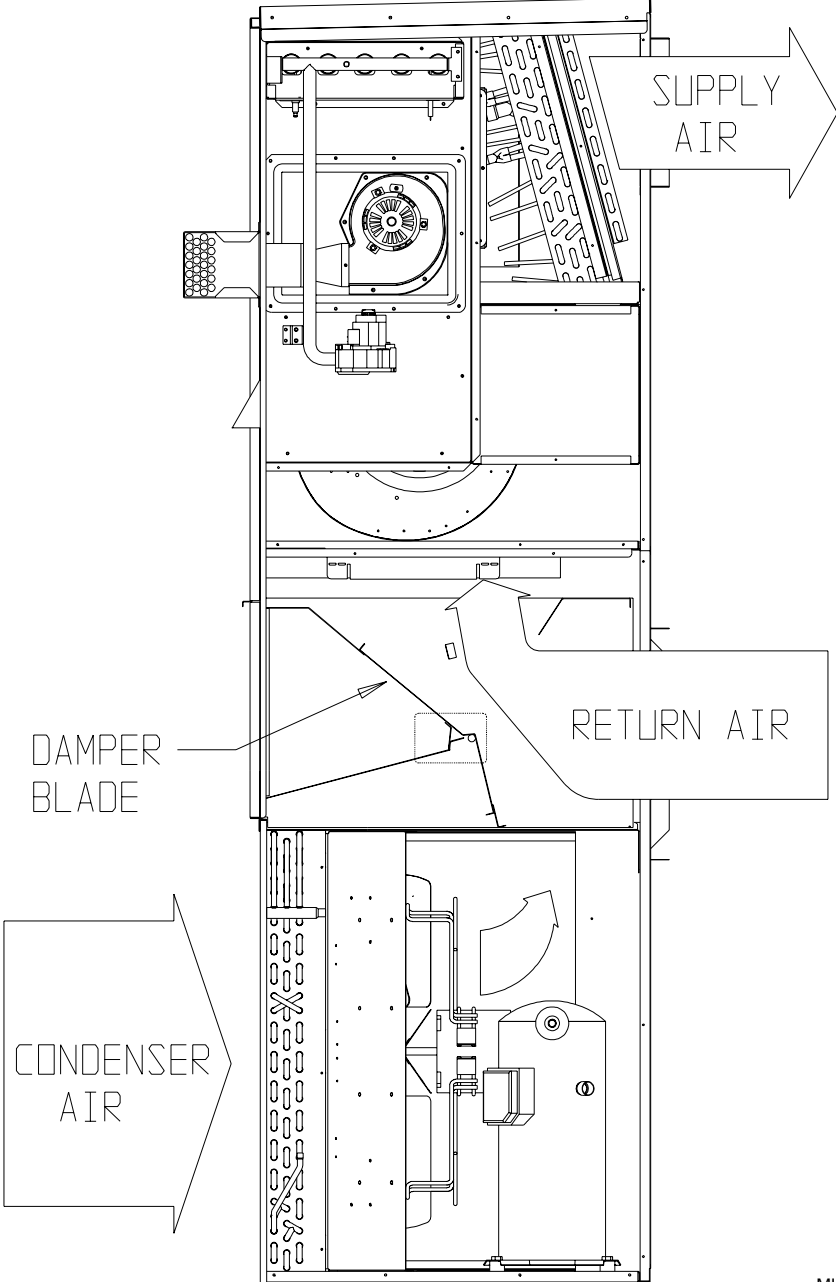

MIS-1466

**FIGURE 6  
ECONOMIZER OPERATION  
FOR SINGLE COMPRESSOR UNIT**

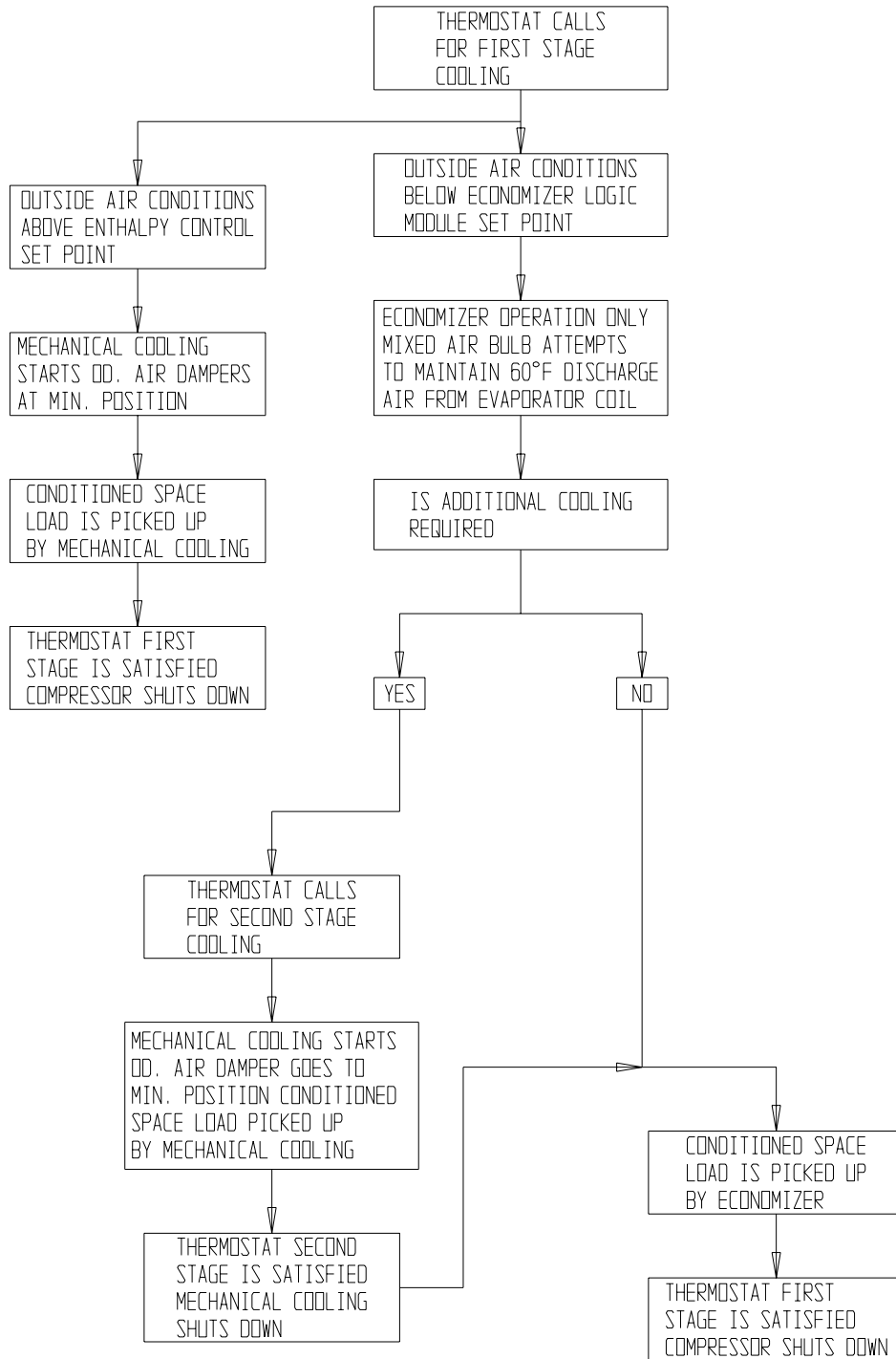

MIS-1626

**WALL THERMOSTATS  
FOR AIR CONDITIONING WITH ECONOMIZER**

Thermostat Part No. 8403-021 (Honeywell T874D1934)  
Subbase part no. 8404-012 (Honeywell Q674A1001)  
2 Stage Cool / 2 Stage Heat

**TABLE 2  
WGEIFM-3B VENTILATION AIR  
FREE BLOW APPLICATION WITH SUPPLY AND RETURN GRILLES**

<b>High Speed @ 0.05 Supply Air Static</b>	
<b>Damper Position</b>	<b>Ventilation Air / Total Air (CFM)</b>
"A"	310 / 1390
"B"	445 / 1400
"C"	525 / 1390
<b>Return Static</b>	<b>0.10</b>
<b>Medium High Speed @ 0.05 Supply Air Static</b>	
<b>Damper Position</b>	<b>Ventilation Air / Total Air (CFM)</b>
"A"	300 / 1225
"B"	410 / 1235
"C"	475 / 1210
<b>Return Static</b>	<b>0.10</b>
<b>Medium Low Speed @ 0.05 Supply Air Static</b>	
<b>Damper Position</b>	<b>Ventilation Air / Total Air (CFM)</b>
"A"	385 / 1050
"B"	370 / 1070
"C"	425 / 1070
<b>Return Static</b>	<b>0.10</b>
<b>Low Speed @ 0.05 Supply Air Static</b>	
<b>Damper Position</b>	<b>Ventilation Air / Total Air (CFM)</b>
"A"	260 / 850
"B"	345 / 840
"C"	400 / 840
<b>Return Static</b>	<b>0.10</b>

**TABLE 3A  
WGEIFM-3B VENTILATION AIR – HIGH SPEED**

<b>HIGH SPEED</b>	<b>0.00 SUPPLY AIR STATIC</b>						
<b>Damper Position</b>	<b>Ventilation Air / Total Air (CFM)</b>						
"A"	180/1500	200/1480	220/1460	240/1400	270/1370	300/1300	330/1290
"B"	360/1490	380/1460	410/1430	440/1390	470/1360	500/1290	520/1285
"C"	540/1480	560/1440	600/1400	640/1375	675/1350	700/1270	730/1280
<b>Return Static</b>	<b>0.00</b>	<b>0.05</b>	<b>0.10</b>	<b>0.15</b>	<b>0.20</b>	<b>0.25</b>	<b>0.30</b>
<b>HIGH SPEED</b>	<b>0.20 SUPPLY AIR STATIC</b>						
<b>Damper Position</b>	<b>Ventilation Air / Total Air (CFM)</b>						
"A"	175/1330	190/1320	210/1310	220/1275	250/1225	280/1160	320/1100
"B"	340/1310	360/1300	390/1285	420/1250	450/1210	480/1150	510/1090
"C"	500-1300	520/1280	570/1260	610/1230	625/1200	650/1140	720/1080
<b>Return Static</b>	<b>0.00</b>	<b>0.05</b>	<b>0.10</b>	<b>0.15</b>	<b>0.20</b>	<b>0.25</b>	<b>0.30</b>
<b>HIGH SPEED</b>	<b>0.40 SUPPLY AIR STATIC</b>						
<b>Damper Position</b>	<b>Ventilation Air / Total Air (CFM)</b>						
"A"	140/1160	155/1130	165/1100	180/1050	230/990	260/930	300/870
"B"	280/1150	300/1120	320/1095	350/1030	410/970	440/910	480/850
"C"	420/1140	440/1110	470/1090	510/1010	590/950	620/890	690/830
<b>Return Static</b>	<b>0.00</b>	<b>0.05</b>	<b>0.10</b>	<b>0.15</b>	<b>0.20</b>	<b>0.25</b>	<b>0.30</b>

**TABLE 3B  
WEIFM-3B VENTILATION AIR – MEDIUM HIGH SPEED**

<b>MEDIUM HIGH SPEED</b>	<b>0.00 SUPPLY AIR STATIC</b>						
<b>Damper Position</b>	<b>Ventilation Air / Total Air (CFM)</b>						
"A"	155/1360	175/1320	195/1290	215/1260	240/1220	260/1180	290/1150
"B"	320/1340	340/1300	370/1280	400/1250	440/1210	480/1170	530/1140
"C"	480/1320	500/1280	540/1270	580/1240	640/1200	700/1160	780/1130
<b>Return Static</b>	<b>0.00</b>	<b>0.05</b>	<b>0.10</b>	<b>0.15</b>	<b>0.20</b>	<b>0.25</b>	<b>0.30</b>
<b>MEDIUM HIGH SPEED</b>	<b>0.20 SUPPLY AIR STATIC</b>						
<b>Damper Position</b>	<b>Ventilation Air / Total Air (CFM)</b>						
"A"	125/1190	145/1160	180/1140	200/1110	220/1080	240/1040	270/1010
"B"	270/1180	290/1150	350/1130	370/1100	410/1065	420/1025	450/990
"C"	420/1170	440/1140	520/1120	540/1090	600/1050	620/1010	650/970
<b>Return Static</b>	<b>0.00</b>	<b>0.05</b>	<b>0.10</b>	<b>0.15</b>	<b>0.20</b>	<b>0.25</b>	<b>0.30</b>
<b>MEDIUM HIGH SPEED</b>	<b>0.40 SUPPLY AIR STATIC</b>						
<b>Damper Position</b>	<b>Ventilation Air / Total Air (CFM)</b>						
"A"	120/1040	135/1020	170/1000	190/925	200/850	220/800	250/760
"B"	250/1030	270/1010	330/955	350/890	385/840	400/780	430/740
"C"	385/1020	400/1000	490/910	510/860	570/830	590/760	620/720
<b>Return Static</b>	<b>0.00</b>	<b>0.05</b>	<b>0.10</b>	<b>0.15</b>	<b>0.20</b>	<b>0.25</b>	<b>0.30</b>

**TABLE 3C  
WEIFM-3B VENTILATION AIR – MEDIUM LOW SPEED**

<b>MEDIUM LOW SPEED</b>	<b>0.00 SUPPLY AIR STATIC</b>						
<b>Damper Position</b>	<b>Ventilation Air / Total Air (CFM)</b>						
"A"	140/1160	160/1125	180/1095	200/1010	230/1050	250/1035	280/1025
"B"	270/1135	320/1100	360/1085	390/1050	420/1040	440/1025	460/1010
"C"	400/1110	470/1075	530/1075	580/140	620/1030	650/1010	670/990
<b>Return Static</b>	<b>0.00</b>	<b>0.05</b>	<b>0.10</b>	<b>0.15</b>	<b>0.20</b>	<b>0.25</b>	<b>0.30</b>
<b>MEDIUM LOW SPEED</b>	<b>0.20 SUPPLY AIR STATIC</b>						
<b>Damper Position</b>	<b>Ventilation Air / Total Air (CFM)</b>						
"A"	120/1020	140/980	170/960	190/930	200/880	220/860	250/840
"B"	250/1010	280/970	330/950	360/920	390/870	410/850	430/830
"C"	380/1000	420/960	500/940	520/910	580/860	600/840	630/820
<b>Return Static</b>	<b>0.00</b>	<b>0.05</b>	<b>0.10</b>	<b>0.15</b>	<b>0.20</b>	<b>0.25</b>	<b>0.30</b>
<b>MEDIUM LOW SPEED</b>	<b>0.40 SUPPLY AIR STATIC</b>						
<b>Damper Position</b>	<b>Ventilation Air / Total Air (CFM)</b>						
"A"	100/870	120/830	160/810	180/760	780/710	NA	NA
"B"	210/860	240/520	310/800	340/750	NA	NA	NA
"C"	325/850	340/810	440/790	460/740	NA	NA	NA
<b>Return Static</b>	<b>0.00</b>	<b>0.05</b>	<b>0.10</b>	<b>0.15</b>	<b>0.20</b>	<b>0.25</b>	<b>0.30</b>

**TABLE 3D  
WEIFM-3B VENTILATION AIR – LOW SPEED**

<b>LOW SPEED</b>	<b>0.00 SUPPLY AIR STATIC</b>						
<b>Damper Position</b>	<b>Ventilation Air / Total Air (CFM)</b>						
"A"	110/940	140/920	170/900	185/880	200/860	220/840	240/820
"B"	220/930	270/910	320/890	360/870	400/850	430/830	460/810
"C"	330/920	390/900	450/880	500/860	550/840	590/820	630/800
<b>Return Static</b>	<b>0.00</b>	<b>0.05</b>	<b>0.10</b>	<b>0.15</b>	<b>0.20</b>	<b>0.25</b>	<b>0.30</b>
<b>LOW SPEED</b>	<b>0.20 SUPPLY AIR STATIC</b>						
<b>Damper Position</b>	<b>Ventilation Air / Total Air (CFM)</b>						
"A"	100/830	130/810	160/780	170/760	190/680	NA	NA
"B"	200/820	250/800	300/770	340/750	NA	NA	NA
"C"	300/810	360/790	430/760	NA	NA	NA	NA
<b>Return Static</b>	<b>0.00</b>	<b>0.05</b>	<b>0.10</b>	<b>0.15</b>	<b>0.20</b>	<b>0.25</b>	<b>0.30</b>
<b>LOW SPEED</b>	<b>0.40 SUPPLY AIR STATIC</b>						
<b>Damper Position</b>	<b>Ventilation Air / Total Air (CFM)</b>						
"A"	90/710	110/680	NA	NA	NA	NA	NA
"B"	170/700	NA	NA	NA	NA	NA	NA
"C"	250/690	NA	NA	NA	NA	NA	NA
<b>Return Static</b>	<b>0.00</b>	<b>0.05</b>	<b>0.10</b>	<b>0.15</b>	<b>0.20</b>	<b>0.25</b>	<b>0.30</b>

**TABLE 4  
WEIFM-5B VENTILATION AIR  
FREE BLOW APPLICATION WITH SUPPLY AND RETURN GRILLES**

<b>High Speed @ 0.05 Supply Air Static</b>	
<b>Damper Position</b>	<b>Ventilation Air / Total Air (CFM)</b>
"A"	240 / 1780
"B"	430 / 1760
"C"	540 / 1710
"D"	650 / 1630
<b>Return Static</b>	<b>0.10</b>
<b>Medium High Speed @ 0.05 Supply Air Static</b>	
<b>Damper Position</b>	<b>Ventilation Air / Total Air (CFM)</b>
"A"	180 / 1480
"B"	385 / 1450
"C"	480 / 1410
"D"	600 / 1375
<b>Return Static</b>	<b>0.10</b>
<b>Low Speed @ 0.05 Supply Air Static</b>	
<b>Damper Position</b>	<b>Ventilation Air / Total Air (CFM)</b>
"A"	145 / 1110
"B"	335 / 1100
"C"	390 / 1070
"D"	500 / 1050
<b>Return Static</b>	<b>0.10</b>

**TABLE 5A  
WEIFM-5B VENTILATION AIR – HIGH SPEED**

<b>HIGH SPEED</b>	<b>0.00 SUPPLY AIR STATIC</b>						
<b>Damper Position</b>	<b>Ventilation Air / Total Air (CFM)</b>						
"A"	240/1895	250/1870	260/1845	280/1820	300/1790	330/1760	360/1740
"B"	435/1870	445/1850	460/1830	480/1815	500/1780	530/1750	560/1735
"C"	560/1815	570/1795	585/1775	605/1760	625/1725	655/1700	675/1685
"D"	680/1730	690/1715	705/1700	725/1690	745/1660	770/1630	785/1615
<b>Return Static</b>	<b>0.00</b>	<b>0.05</b>	<b>0.10</b>	<b>0.15</b>	<b>0.20</b>	<b>0.25</b>	<b>0.30</b>
<b>HIGH SPEED</b>	<b>0.20 SUPPLY AIR STATIC</b>						
<b>Damper Position</b>	<b>Ventilation Air / Total Air (CFM)</b>						
"A"	205/1615	220/1600	235/1575	265/1560	285/1530	320/1500	355/1430
"B"	380/1605	400/1590	410/1565	425/1550	445/1520	500/1480	540/1420
"C"	490/1560	510/1545	520/1510	535/1495	560/1460	610/1430	640/1385
"D"	590/1460	610/1445	635/1415	645/1400	675/1360	710/1340	730/1300
<b>Return Static</b>	<b>0.00</b>	<b>0.05</b>	<b>0.10</b>	<b>0.15</b>	<b>0.20</b>	<b>0.25</b>	<b>0.30</b>
<b>HIGH SPEED</b>	<b>0.40 SUPPLY AIR STATIC</b>						
<b>Damper Position</b>	<b>Ventilation Air / Total Air (CFM)</b>						
"A"	180/1315	195/1300	220/1275	250/1240	270/1170	310/1120	355/1045
"B"	315/1305	330/1280	350/1250	395/1210	415/1140	455/1090	540/1015
"C"	410/1245	425/1220	440/1190	485/1155	505/1090	555/1020	600/985
"D"	495/1165	515/1145	530/1105	555/1090	575/1020	615/990	660/935
<b>Return Static</b>	<b>0.00</b>	<b>0.05</b>	<b>0.10</b>	<b>0.15</b>	<b>0.20</b>	<b>0.25</b>	<b>0.30</b>

**TABLE 5B  
WGEIFM-5B VENTILATION AIR – MEDIUM SPEED**

<b>MEDIUM SPEED</b>	<b>0.00 SUPPLY AIR STATIC</b>						
<b>Damper Position</b>	<b>Ventilation Air / Total Air (CFM)</b>						
"A"	165/1540	180/1535	195/1530	220/1525	250/1510	295/1495	340/1475
"B"	360/1525	375/1515	390/1505	420/1500	450/1480	495/1460	540/1440
"C"	470/1490	485/1480	500/1470	530/1465	560/1440	605/1420	625/1400
"D"	590/1455	615/1445	630/1440	650/1430	670/1400	715/1380	735/1365
<b>Return Static</b>	<b>0.00</b>	<b>0.05</b>	<b>0.10</b>	<b>0.15</b>	<b>0.20</b>	<b>0.25</b>	<b>0.30</b>
<b>MEDIUM SPEED</b>	<b>0.20 SUPPLY AIR STATIC</b>						
<b>Damper Position</b>	<b>Ventilation Air / Total Air (CFM)</b>						
"A"	125/1325	150/1310	170/1290	200/1275	230/1250	280/1200	330/1170
"B"	320/1310	345/1295	370/1275	390/1260	420/1230	480/1175	535/1155
"C"	405/1270	430/1255	455/1235	470/1220	500/1180	550/1150	590/1120
"D"	505/1225	530/1200	555/1185	580/1175	610/1150	630/1120	680/1080
<b>Return Static</b>	<b>0.00</b>	<b>0.05</b>	<b>0.10</b>	<b>0.15</b>	<b>0.20</b>	<b>0.25</b>	<b>0.30</b>
<b>MEDIUM SPEED</b>	<b>0.40 SUPPLY AIR STATIC</b>						
<b>Damper Position</b>	<b>Ventilation Air / Total Air (CFM)</b>						
"A"	120/1060	140/1020	185/1000	190/985	220/920	280/860	300/700
"B"	255/1045	275/1005	315/980	370/955	410/880	460/800	520/670
"C"	325/1000	355/960	390/940	435/920	480/850	520/750	580/660
"D"	410/960	440/940	470/900	505/885	535/815	580/710	600/635
<b>Return Static</b>	<b>0.00</b>	<b>0.05</b>	<b>0.10</b>	<b>0.15</b>	<b>0.20</b>	<b>0.25</b>	<b>0.30</b>

**TABLE 5C  
WGEIFM-5B VENTILATION AIR – LOW SPEED**

<b>LOW SPEED</b>	<b>0.00 SUPPLY AIR STATIC</b>						
<b>Damper Position</b>	<b>Ventilation Air / Total Air (CFM)</b>						
"A"	75/1190	110/1180	150/1165	190/1150	235/1130	290/1100	340/1075
"B"	270/1165	305/1150	345/1140	390/1130	435/1100	490/1070	540/1055
"C"	325/1140	360/1130	400/1125	430/1110	475/1090	530/1060	560/1040
"D"	445/1120	480/1110	520/1100	550/1090	595/1070	640/1040	655/1025
<b>Return Static</b>	<b>0.00</b>	<b>0.05</b>	<b>0.10</b>	<b>0.15</b>	<b>0.20</b>	<b>0.25</b>	<b>0.30</b>
<b>LOW SPEED</b>	<b>0.20 SUPPLY AIR STATIC</b>						
<b>Damper Position</b>	<b>Ventilation Air / Total Air (CFM)</b>						
"A"	55/995	90/970	130/950	160/925	205/890	280/870	330/840
"B"	230/980	265/955	305/940	370/910	415/870	480/850	520/820
"C"	285/955	320/925	360/910	390/895	435/850	510/810	550/790
"D"	385/930	420/910	460/900	495/880	540/840	590/790	610/760
<b>Return Static</b>	<b>0.00</b>	<b>0.05</b>	<b>0.10</b>	<b>0.15</b>	<b>0.20</b>	<b>0.25</b>	<b>0.30</b>
<b>LOW SPEED</b>	<b>0.40 SUPPLY AIR STATIC</b>						
<b>Damper Position</b>	<b>Ventilation Air / Total Air (CFM)</b>						
"A"	40/740	75/700	115/650	140/600	NA	NA	NA
"B"	180/730	215/680	255/630	360/585	NA	NA	NA
"C"	210/710	245/660	290/610	380/570	NA	NA	NA
"D"	290/690	325/650	375/590	450/560	NA	NA	NA
<b>Return Static</b>	<b>0.00</b>	<b>0.05</b>	<b>0.10</b>	<b>0.15</b>	<b>0.20</b>	<b>0.25</b>	<b>0.30</b>



**FIGURE 7  
LOW VOLTAGE WIRING**

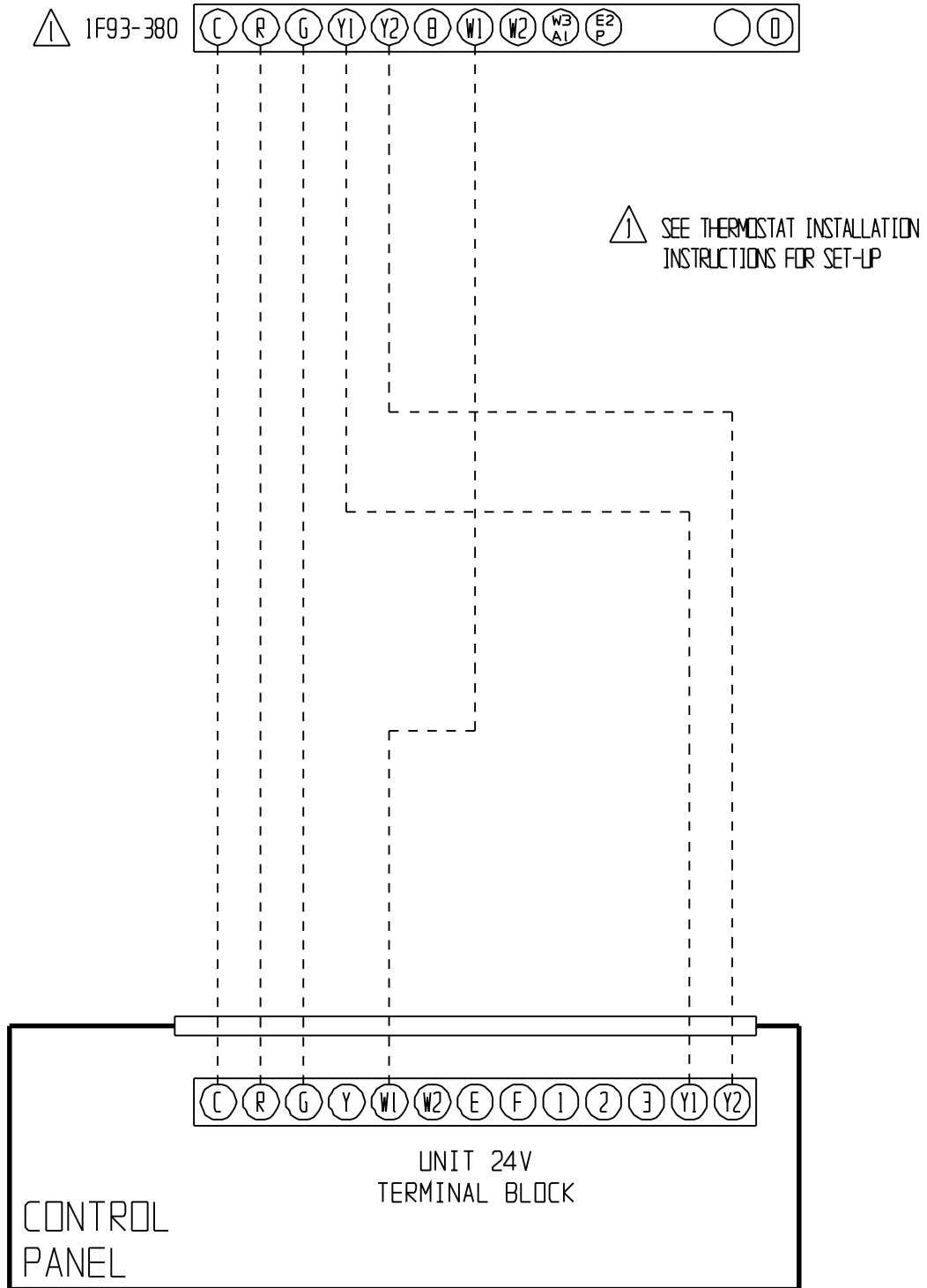

MIS-1717



# DANGER

\* ELECTRICAL SHOCK HAZARD  
 \* DISCONNECT POWER BEFORE  
 SERVICING

## COLOR CODE

BLACK	BK
BROWN	BR
RED	R
ORANGE	O
YELLOW	Y
GREEN	G
BLUE	BL
VIOLET (PURPLE)	V (PR)
GRAY (SLATE)	GY (S)
WHITE	W
TAN	T
PINK	PK

## COMPONENT CODE

CR	CONTROL RELAY
ELM	ECON. LOGIC MODULE
ES	ENTHALPY SENSOR
PL1	PLUG #1 (9 PIN MALE)
PL2	PLUG #2 (9 PIN FEMALE)
TH	THERMISTOR
TS	TERMINAL STRIP (24V)

### CONTROL PANEL

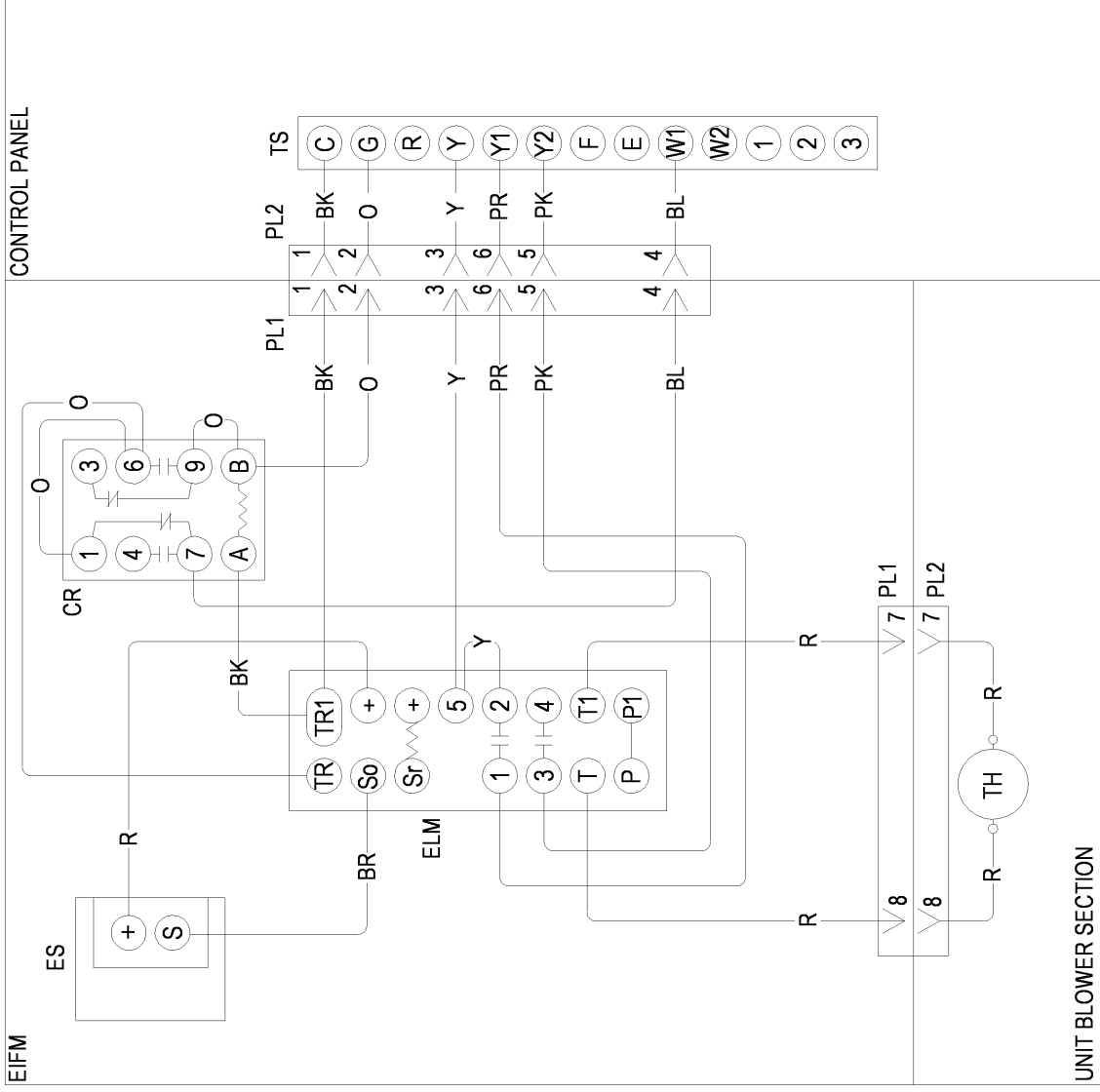

EIFM

UNIT BLOWER SECTION

4056-176

1-4-01