QTEC SERIES PACKAGED HEAT PUMP

INSTALLATION INSTRUCTIONS

Models:

QH242

QH302

QH362

QH422

QH482

QH602

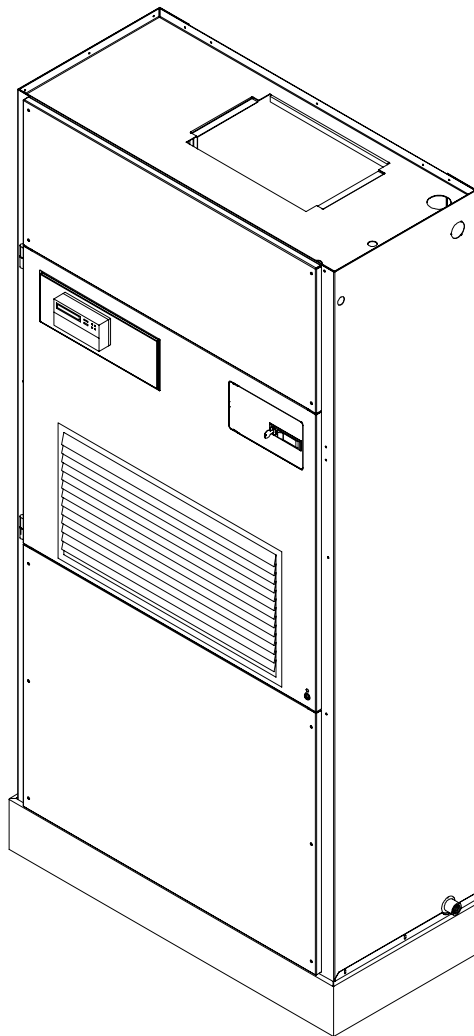

MIS-1554



CLIMATE CONTROL SOLUTIONS

Bard Manufacturing Company
Bryan, Ohio 43506

Since 1914 . . . Moving ahead, just as planned.

Manual: 2100-379D
Supersedes: 2100-379C
File: Vol II Tab 14
Date: 10-23-01

CONTENTS

Getting Other Information and Publications

For more information, contact these publishers: 1

QTEC General Information

QTEC Model Nomenclature	2
Shipping Damage	6
Unit Removal From Skid	6
Handling Unit After Removal From Skid	7
General	7
Minimum Installation Height	7
Duct Work	9
Filters	9
Fresh Air Intake	10
Condensate Drain	10
Service Light	11

Installation Instructions

Mounting the Unit	12
Wiring — Main Power	13
Wiring — Low Voltage Wiring	13
Low Voltage Connections	14

Figures

Figure 1 Unit Dimensions	5
Figure 2 Air Seal on Bottom of Unit	6
Figure 3 Removal of Unit From Skid	6
Figure 4 Unit on Appliance Cart for Moving	7
Figure 5 Installation With Free Blow Plenum	8
Figure 6 Ducted Application	8
Figure 7 Supply Duct Connections	9
Figure 8 Filter Location	9
Figure 9 Side Drain	10
Figure 10 Optional Rear Drain	10
Figure 11 Rear Drain (Top View)	11
Figure 12 Unit Mounting	11
Figure 13 Screws in Wheels of Unit	12
Figure 14 Component Location	13
Figure 15 Thermostat Plug Terminals	15
Figure 16 Thermostat Wiring Diagram "X" Option	16
Figure 17 Thermostat Wiring Diagram "A" Option	17
Figure 18 Thermostat Wiring Diagram "D" Option ...	18
Figure 19 Fresh Air Damper Removal	22
Figure 20 QERV Removal	23
Figure 21 Heat Pump Control Board	24
Figure 22 Fan Blade Setting	28

Start Up

Description of Standard Equipment	19
Optional CFM (QH361QH421and QH481 Only)	19
Important Installer Note	19
Phase Monitor	19
Three Phase Scroll Compressor Start Up Information	19
Service Hints	20
Mist Eliminator Service	20
Vent Options	21
Sequence of Operation	24
Optional Climate Controls Sequence of Operation	24
Pressure Service Ports	24
Defrost Cycle	25

Troubleshooting

Solid State Heat Pump Control Troubleshooting Procedure	27
Checking Temperature Sensor	27
Fan Blade Setting Dimensions	28
Refrigerant Charge	28
Pressure Charts	29 - 30

Tables

Table 1 Factory Built-In Electric Heat Table	2
Table 2 Electrical Specifications	3
Table 2A Electrical Specifications	4
Table 3 Operating Voltage Range	13
Table 4 Wall Thermostats and Subbase Combinations	15
Table 5 Troubleshooting	26
Table 6 Temperature vs Resistance of Temperature Sensor	27
Table 7 Fan Blade Dimensions	28
Table 8 Super Heat at Compressor	28
Table 9 Indoor Blower Performance	28
Table 10 Cooling Pressure	29
Table 11 Heating Pressure	30

QTEC Series General Information

QTEC MODEL NOMENCLATURE

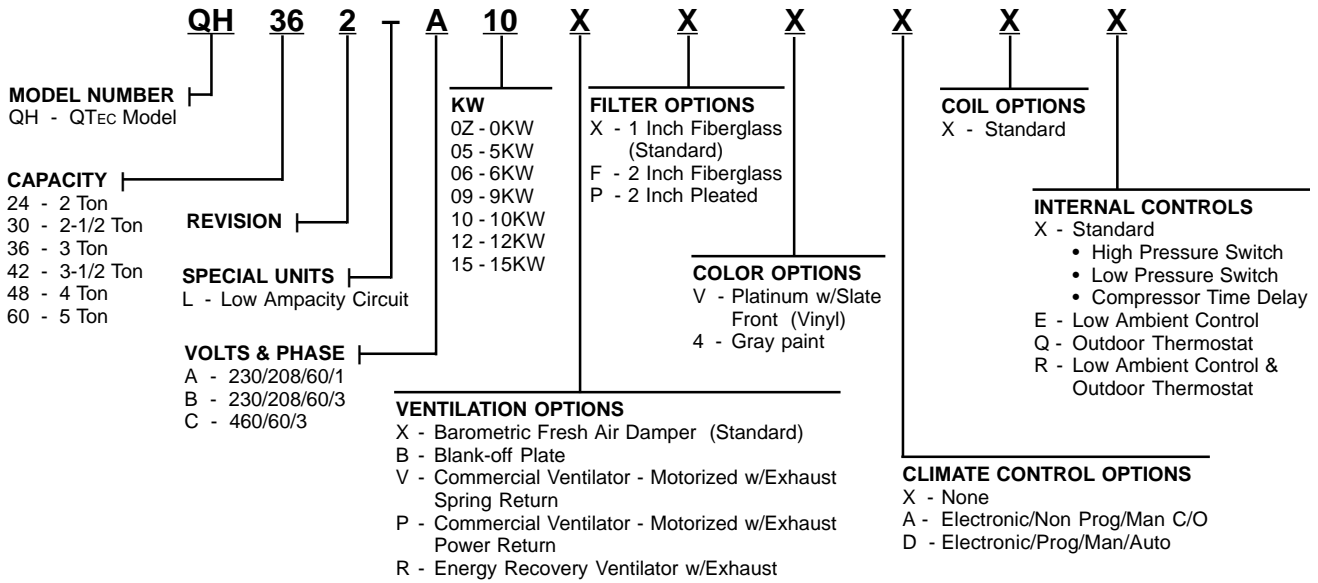

**TABLE 1
FACTORY BUILT-IN ELECTRIC HEAT TABLE**

Models	QH242-A QH302-A		QH242-B		QH302-B		QH242-C	QH302-C	QH362-A QH422-A QH482-A QH602-A		QH362-B QH422-B QH482-B QH602-B		QH362-C QH422-C QH482-C QH602-C
	240V-1	208V-1	240V-1	208V-1	240V-1	208V-1	480V-3	480V-3	240V-1	208V-1	240V-1	208V-1	480V-3
KW	BTUH	BTUH	BTUH	BTUH	BTUH	BTUH	BTUH	BTUH	BTUH	BTUH	BTUH	BTUH	BTUH
5.0	16,380	12,290							16,380	12,290			
6.0			20,500	15,360	20,500	15,360	20,500	20,500			20,500	15,360	20,500
9.0			30,700	23,000	30,700	23,000	30,700	30,700			30,700	23,000	30,700
10.0	32,670	24,570							32,670	24,570			
12.0					41,000	30,700		41,000					
15.0									49,150	36,860	49,150	36,860	49,150

**TABLE 2
ELECTRICAL SPECIFICATIONS**

MODELS	RATED VOLTS & PHASES	SINGLE CIRCUIT					DUAL CIRCUIT							
		NO. FIELD POWER CIRCUITS	③ MINIMUM CIRCUIT AMPACITY	① MAXIMUM EXTERNAL FUSE OR CIRCUIT BREAKER	② FIELD POWER WIRE SIZE	② GROUND WIRE SIZE	③ MINIMUM CIRCUIT AMPACITY		① MAXIMUM EXTERNAL FUSE OR CIRCUIT BREAKER		② FIELD POWER WIRE SIZE		② GROUND WIRE SIZE	
							CKT A	CKT B	CKT A	CKT B	CKT A	CKT B	CKT A	CKT B
QH242-A0Z -A05 -A10	230/208-1	1 1 1 OR 2	22 47 72	30 50 80	10 8 4	10 10 8	-- -- 22	-- -- 50	-- -- 30	-- -- 50	-- -- 10	-- -- 8	-- -- 10	-- -- 10
QH242-B0Z -B06 -B09	230/208-3	1 1 1	17 35 44	20 35 45	12 8 8	12 10 10	-- -- --	-- -- --	-- -- --	-- -- --	-- -- --	-- -- --	-- -- --	-- -- --
QH242-C0Z -C06 -C09	460-3	1 1 1	8 17 22	15 20 25	14 12 10	14 12 10	-- -- --	-- -- --	-- -- --	-- -- --	-- -- --	-- -- --	-- -- --	-- -- --
QH302-A0Z -A05 -A10	230/208-1	1 1 1 OR 2	24 49 74	35 50 80	8 8 4	10 10 8	-- -- 24	-- -- 50	-- -- 30	-- -- 50	-- -- 10	-- -- 8	-- -- 10	-- -- 10
QH302-B0Z -B06 -B09 -B12	230/208-3	1 1 1 1	18 36 45 54	25 40 45 60	10 8 6 6	10 10 10 10	-- -- -- --	-- -- -- --	-- -- -- --	-- -- -- --	-- -- -- --	-- -- -- --	-- -- -- --	-- -- -- --
QH302-C0Z -C06 -C09 -C12	460-3	1 1 1 1	9 18 23 27	15 20 25 30	14 12 10 8	14 12 10 10	-- -- -- --	-- -- -- --	-- -- -- --	-- -- -- --	-- -- -- --	-- -- -- --	-- -- -- --	-- -- -- --
QH362-A0Z -A05 -A10 ④ -A15	230/208-3	1 1 1 OR 2 1 OR 2	29 54 79 82	45 60 90 90	8 6 4 4	10 10 8 8	-- -- 29 32	-- -- 50 50	-- -- 40 40	-- -- 50 50	-- -- 8 8	-- -- 8 8	-- -- 10 10	-- -- 10 10
QH362-B0Z -B06 -B09 ⑤ -B15	230/208-3	1 1 1 1	23 41 50 52	30 45 50 60	10 8 8 6	10 10 10 10	-- -- -- --	-- -- -- --	-- -- -- --	-- -- -- --	-- -- -- --	-- -- -- --	-- -- -- --	-- -- -- --
QH362-C0Z -C06 -C09 ⑤ -C15	460-3	1 1 1 1	11 20 24 26	15 20 30 30	14 10 10 10	14 10 10 10	-- -- -- --	-- -- -- --	-- -- -- --	-- -- -- --	-- -- -- --	-- -- -- --	-- -- -- --	-- -- -- --

- ① Maximum size of the time delay fuse or HACR type circuit breaker for protection of field wiring conductors.
- ② Based on 75° C copper wire. All wiring must conform to the National Electrical Code and all local codes.
- ③ These "Minimum Circuit Ampacity" values are to be used for sizing the field power conductors. Refer to the National Electric Code (latest revision), article 310 for power conductor sizing. CAUTION: When more than one field power conductor circuit is run through one conduit, the conductors must be derated. Pay special attention to Note 8 of Table 310 regarding Ampacity Adjustment Factors when more than three conductors are in a raceway.
- ④ Maximum KW that can operate with heat pump on is 10KW. Other 5KW energizes during emergency heating only.
- ⑤ Maximum KW that can operate with heat pump on is 9KW. Other 6KW energizes during emergency heating only.

ELECTRICAL SPECIFICATIONS CONTINUED ON PAGE 4 TABLE 2A

**TABLE 2A
ELECTRICAL SPECIFICATIONS
(CONTINUED FROM PAGE 3)**

MODEL	RATED VOLTS & PHASE	SINGLE CIRCUIT					DUAL CIRCUIT							
		NO. FIELD POWER CIRCUITS	③ MINIMUM CIRCUIT AMPACITY	① MAXIMUM EXTERNAL FUSE OR CIRCUIT BREAKER	② FIELD POWER WIRE SIZE	② GROUND WIRE SIZE	③ MINIMUM CIRCUIT AMPACITY		① MAXIMUM EXTERNAL FUSE OR CIRCUIT BREAKER		② FIELD POWER WIRE SIZE		② GROUND WIRE SIZE	
							CKT A	CKT B	CKT A	CKT B	CKT A	CKT B	CKT A	CKT B
QH422-A0Z -A05 -A10 ④ -A15	230/208-1	1 1 1 OR 2 1 OR 2	33 58 83 83	50 60 90 90	8 6 4 4	10 10 8 8	-- -- 33 33	-- -- 50 50	-- -- 40 40	-- -- 50 50	-- -- 8 8	-- -- 8 8	-- -- 10 10	-- -- 10 10
QH422-B0Z -B06 -B09 ⑤ -B15	230/208-3	1 1 1 1	24 43 52 52	30 45 50 60	10 8 6 6	10 10 10 10	-- -- -- --	-- -- -- --	-- -- -- --	-- -- -- --	-- -- -- --	-- -- -- --	-- -- -- --	
QH422-C0Z -C06 -C09 ⑤ -C15	460-3	1 1 1 1	16 25 30 30	20 25 30 30	12 10 10 10	12 10 10 10	-- -- -- --	-- -- -- --	-- -- -- --	-- -- -- --	-- -- -- --	-- -- -- --	-- -- -- --	
QH482-A0Z -A05 -A10 ④ -A15	230/208-1	1 1 1 OR 2 1 OR 2	36 61 86 86	60 70 100 100	8 6 3 3	10 8 6 6	-- 36 36 36	-- 25 50 50	-- 60 60 60	-- 25 50 50	-- 8 8 8	-- 10 8 8	-- 10 10 10	-- 10 10 10
QH482-B0Z -B05 -B10 ⑤ -B15	230/208-3	1 1 1 1	26 44 53 53	40 50 60 60	8 8 6 6	10 10 10 10	-- -- -- --	-- -- -- --	-- -- -- --	-- -- -- --	-- -- -- --	-- -- -- --	-- -- -- --	
QH482-C0Z -C06 -C09 ⑤ -C15	460-3	1 1 1 1	14 23 27 27	15 25 30 30	14 10 10 10	14 10 10 10	-- -- -- --	-- -- -- --	-- -- -- --	-- -- -- --	-- -- -- --	-- -- -- --	-- -- -- --	
QH602-A0Z -A05 -A10 ④ -A15	230/208-1	1 1 or 2 1 or 2 1 or 2	45 70 95 95	60 90 110 110	8 6 2 2	10 8 6 6	-- 45 45 45	-- 25 50 50	-- 60 60 60	-- 25 50 50	-- 8 8 8	-- 10 8 8	-- 10 10 10	-- 10 10 10
QH602-B0Z -B09 ⑤ -B15	230/208-3	1 1 1	34 60 60	45 70 70	8 6 6	10 10 10	-- -- --	-- -- --	-- -- --	-- -- --	-- -- --	-- -- --	-- -- --	
QH602-C0Z -C09 ⑤ -C15	460-3	1 1 1	17 30 30	25 35 35	10 8 8	10 10 10	-- -- --	-- -- --	-- -- --	-- -- --	-- -- --	-- -- --	-- -- --	

- ① Maximum size of the time delay fuse or HACR type circuit breaker for protection of field wiring conductors.
- ② Based on 75° C copper wire. All wiring must conform to the National Electrical Code and all local codes.
- ③ These "Minimum Circuit Ampacity" values are to be used for sizing the field power conductors. Refer to the National Electric Code (latest revision), article 310 for power conductor sizing. CAUTION: When more than one field power conductor circuit is run through one conduit, the conductors must be derated. Pay special attention to Note 8 of Table 310 regarding Ampacity Adjustment Factors when more than three conductors are in a raceway.
- ④ Maximum KW that can operate with heat pump on is 10KW. Other 5KW energizes during emergency heating only.
- ⑤ Maximum KW that can operate with heat pump on is 9KW. Other 6KW energizes during emergency heating only.

**FIGURE 1
UNIT DIMENSIONS**

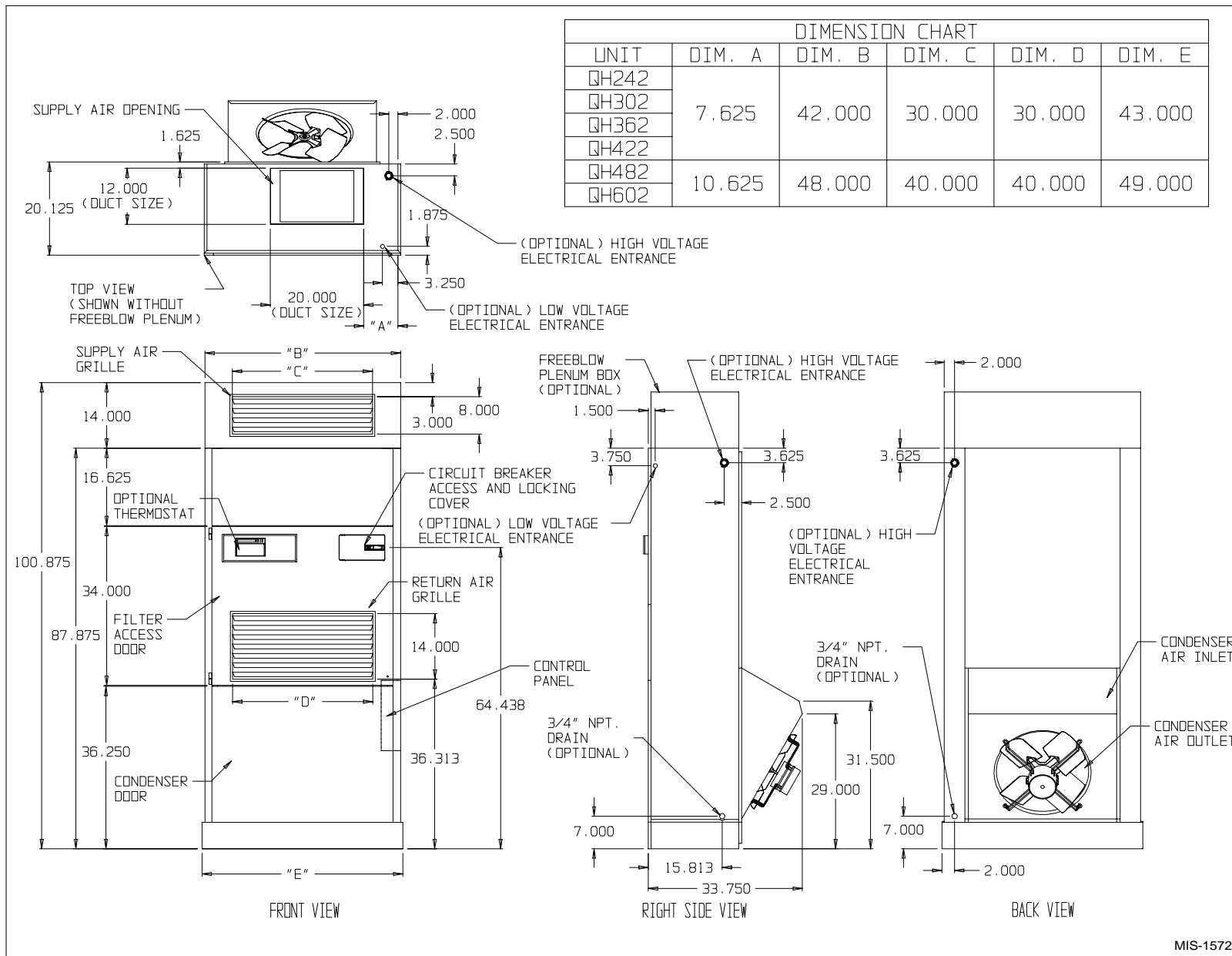

SHIPPING DAMAGE

Upon receipt of equipment, the carton should be checked for external signs of shipping damage. The skid must remain attached to the unit until the unit is ready for installation. If damage is found, the receiving party must contact the last carrier immediately, preferably in writing, requesting inspection by the carrier's agent.

UNIT REMOVAL FROM SKID

WARNING

This unit is heavy and requires more than one person to handle and remove from the skid. Check unit wheels to ensure that wheels are locked before removing from skid. Extreme caution must be taken to prevent injury to personnel and damage to the unit.

It is recommended that the unit not be removed from the skid with a fork lift since the air seal under the unit could be damaged. See Figure 2.

The shipping brackets on each side of the unit must be removed and discarded. See Figure 3-A. The return air grille panel can be removed to provide a place to hold

FIGURE 2
AIR SEAL UNDER QT_{EC} UNIT

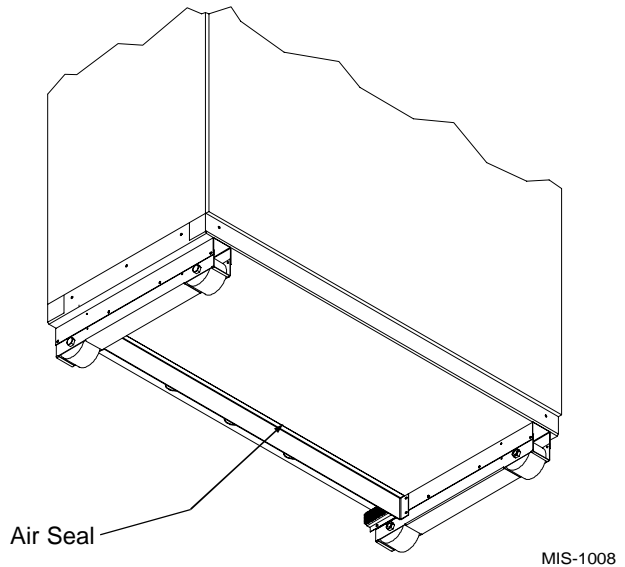

the unit. The unit can be slid forward on the skid until the front wheels hang over the edge of the skid. See Figure 3-B. The unit can be tipped forward and slid down the edge of the skid until the front wheels touch the ground. See Figure 3-C. The wheels will not roll. They are shipped from the factory locked so they will not roll. The back of the skid will have to be held down to keep it from tipping up. The skid can be slid out from under the unit. The unit can then be set upright.

FIGURE 3
REMOVAL OF UNIT FROM SKID

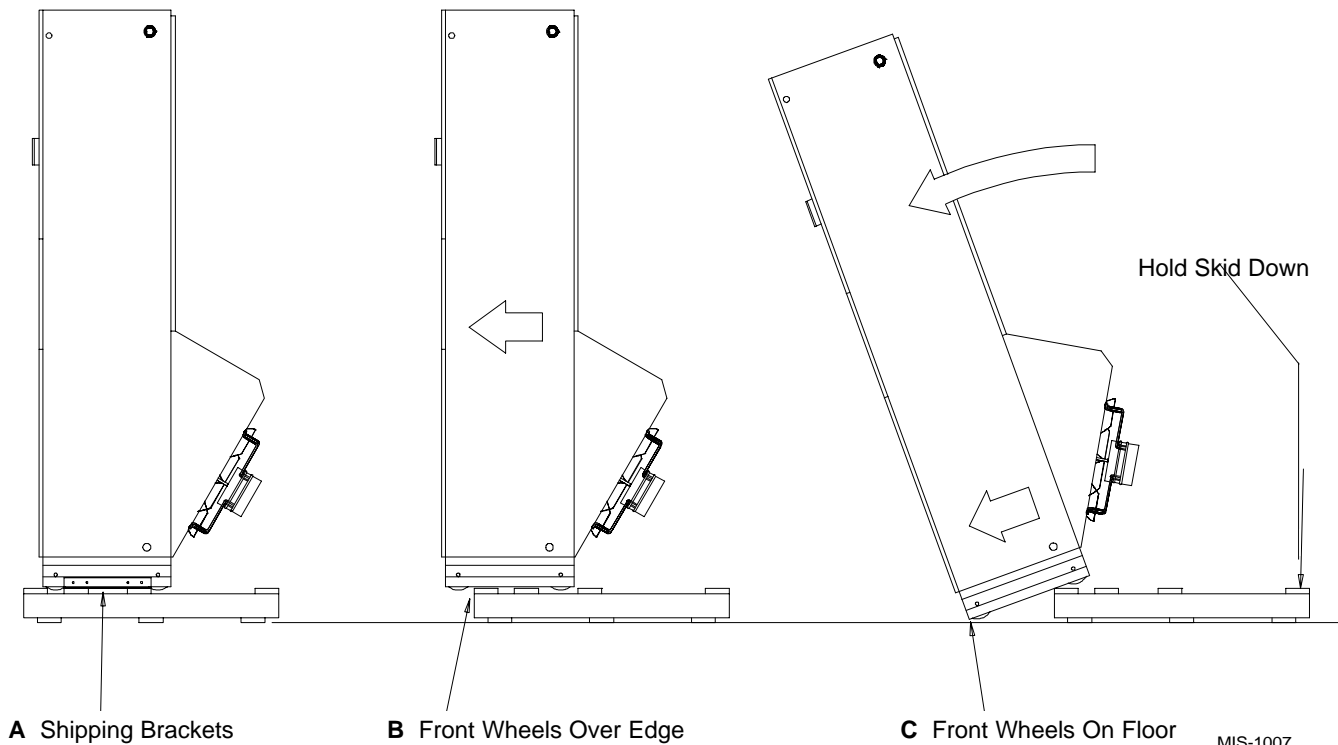

HANDLING UNIT AFTER REMOVAL FROM SKID

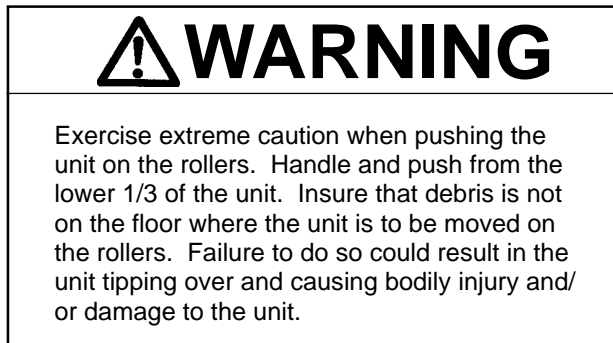

The unit will have to be turned sideways and removed from the skid to fit through a 36" doorway. If the door height allows, the unit can be slid sideways through the door.

If the unit can not be slid through the door, then the unit will have to be put on a cart and tipped down to roll through the door. It is recommended that an appliance cart be used with a strap to hold the unit on the cart.

**FIGURE 4
UNIT ON APPLIANCE CART**

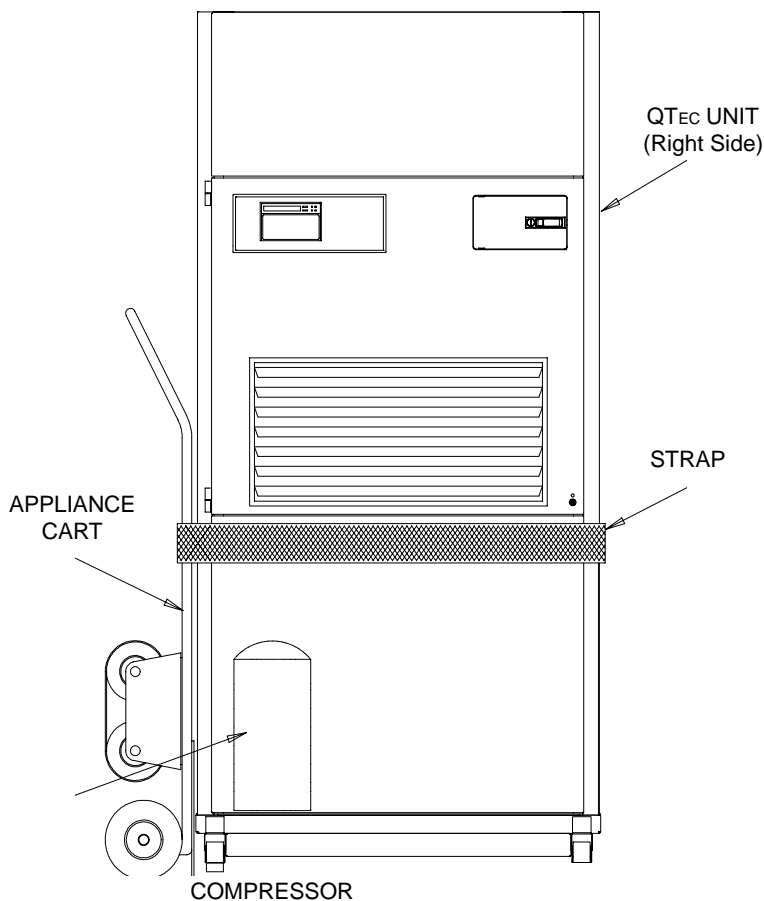

MIS-1555

The wheels of the unit *must be locked*. If the wheels were allowed to roll, the unit could roll off the cart. *The unit should always be carted from the left side.* This is the side where the compressor is located. See Figure 4. The blade of the appliance cart should be slid under the wheels of the unit. The strap of the appliance cart should be placed around the unit and strapped tightly. Help will be required to tip the unit back onto the cart. The unit can be leaned far enough back to be rolled through the door. Be careful when setting the unit back up to keep from damaging the unit.

GENERAL

The equipment covered in this manual is to be installed by trained, experienced service and installation technicians.

The unit is designed for use with or without duct work. For use without duct work, Plenum Box QPB42 is recommended.

These instructions explain the recommended method to install the air cooled self-contained unit and the electrical wiring connections to the unit.

These instructions and any instructions packaged with any separate equipment required to make up the entire air conditioning system should be carefully read before beginning the installation. Note particularly "Start Procedure" and any tags and/or labels attached to the equipment.

While these instructions are intended as a general recommended guide, they do not supersede any national and/or local codes in any way. Authorities having jurisdiction should be consulted before the installation is made. See Page 1 for information on codes and standards.

Size of unit for a proposed installation should be based on heat loss calculation made according to methods of Air Conditioning Contractors of America (ACCA). The air duct should be installed in accordance with the Standards of the National Fire Protection Systems of Other Than Residence Type, NFPA No. 90A, and Residence Type Warm Air Heating and Air Conditioning Systems, NFPA No. 90B. Where local regulations are at a variance with instructions, installer should adhere to local codes.

MINIMUM INSTALLATION HEIGHT

The minimum installation height of the unit with a Free Blow Plenum is 8 ft. 6 in. This provides enough clearance for the plenum to be removed. See Figure 5.

The minimum installation height for ducted applications is 8 ft. 4-1/2 in. This provides enough clearance to install the duct work. See Figure 6.

**FIGURE 5
INSTALLATION WITH FREE BLOW PLENUM**

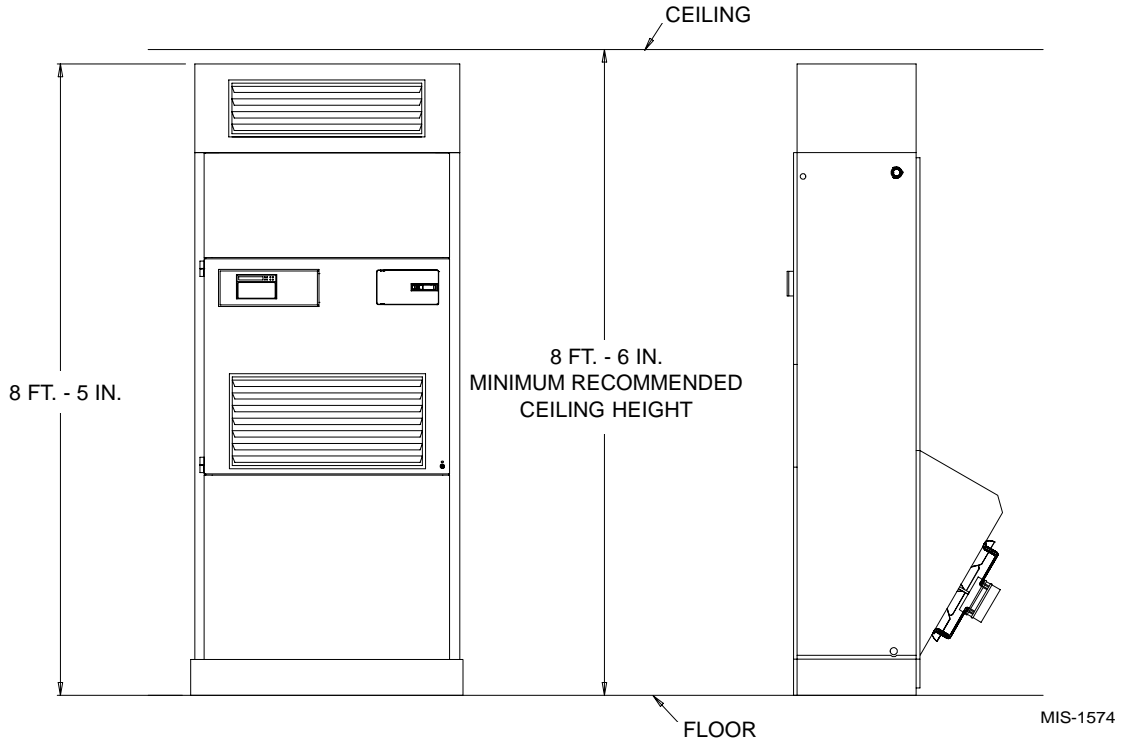

**FIGURE 6
DUCTED APPLICATION**

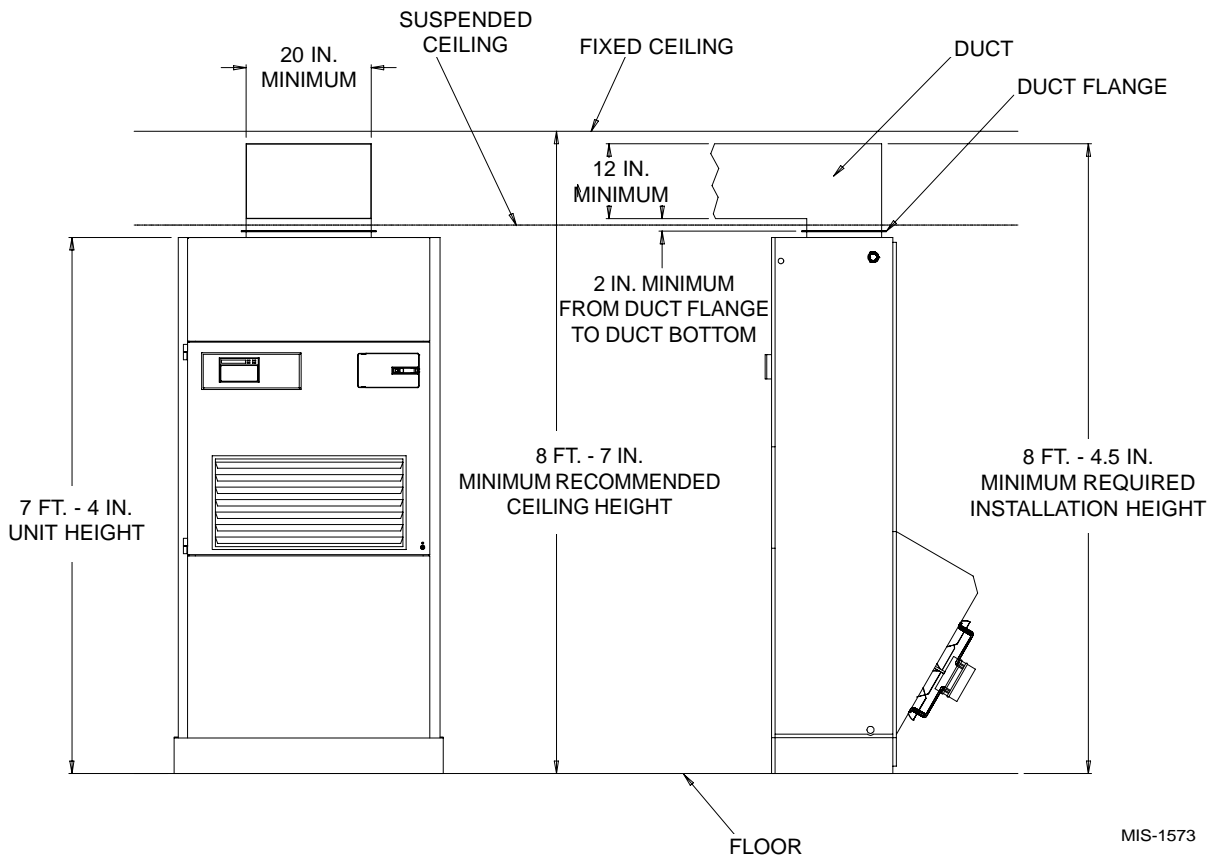

DUCT WORK

Any heat pump is more critical of proper operating charge and an adequate duct system than a straight air conditioning unit. All duct work must be properly sized for the design air flow requirement of the equipment. Air Conditioning Contractors of America (ACCA) is an excellent guide to proper sizing. All duct work or portions thereof not in the conditioned space should be properly insulated in order to both conserve energy and prevent condensation or moisture damage. When duct runs through unheated spaces, it should be insulated with a minimum of one inch of insulation. Use insulation with a vapor barrier on the outside of the insulation. Flexible joints should be used to connect the duct work to the equipment in order to keep the noise transmission to a minimum.

The QTEC series heat pump has provision to attach a supply air duct to the top of the unit. Duct connection size is 12 inches x 20 inches. The duct work is field supplied and must be attached in a manner to allow for ease of removal when it becomes necessary to slide the unit out from the wall for service. See Figure 7 for suggested attachment method.

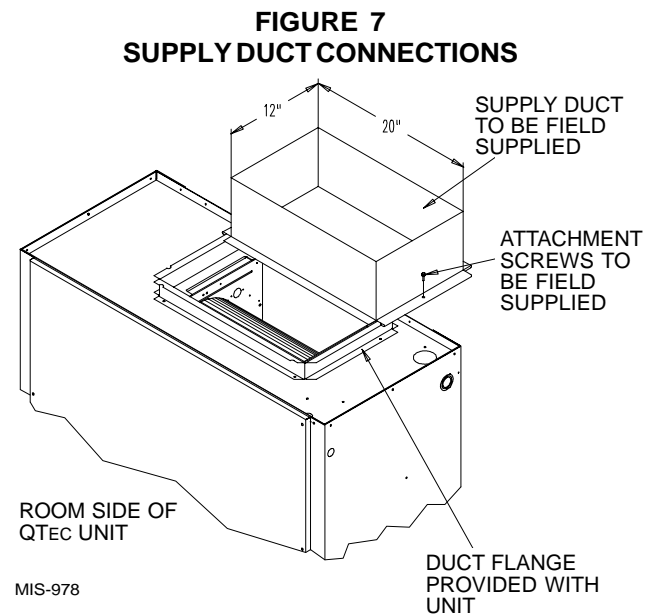

NOTE: Unit cabinet, supply air duct and free blow plenum are approved for "0" clearance to combustible material.

The QTEC series heat pumps are designed for use with free return (non-ducted) and either free blow with the use of QPB Plenum Box or a duct supply air system.

The QPB and QPBHW Plenum Box mounts on top of the unit and has both vertically and horizontally adjustable louvers on the front discharge grille.

For hot water coil option a QPBHW_{xx}-F for free blow or QPBHW_{xx}-D for ducted airflow is used

When used with a ducted supply, a QCX Cabinet Extension can be used to conceal the duct work above the unit to the ceiling. This extends 20" above the unit for a total height above the floor of 10'-7/8". The unit is equipped with a variable speed indoor blower motor which increases in speed with an increase in duct static pressure. The unit will therefore deliver proper rated air flow up to the maximum ESP shown in Table 8. However, for quiet operation of the air system, the duct static should be kept as low as practical, within the guidelines of good duct design.

FILTERS

Two 1 inch throw away filters [(1) 16x16 and (1) 16x20] are supplied with each unit. The filters slide into filter brackets. Refer to Figure 8.

The filters are serviced from the inside of the building by opening the hinged door. This door is attached by 1/4 turn fasteners and one locking latch.

The internal filter brackets are adjustable to accommodate 2 inch filters. The tabs for the 1 inch filters must be bent down to allow the 2 inch filters to slide in place.

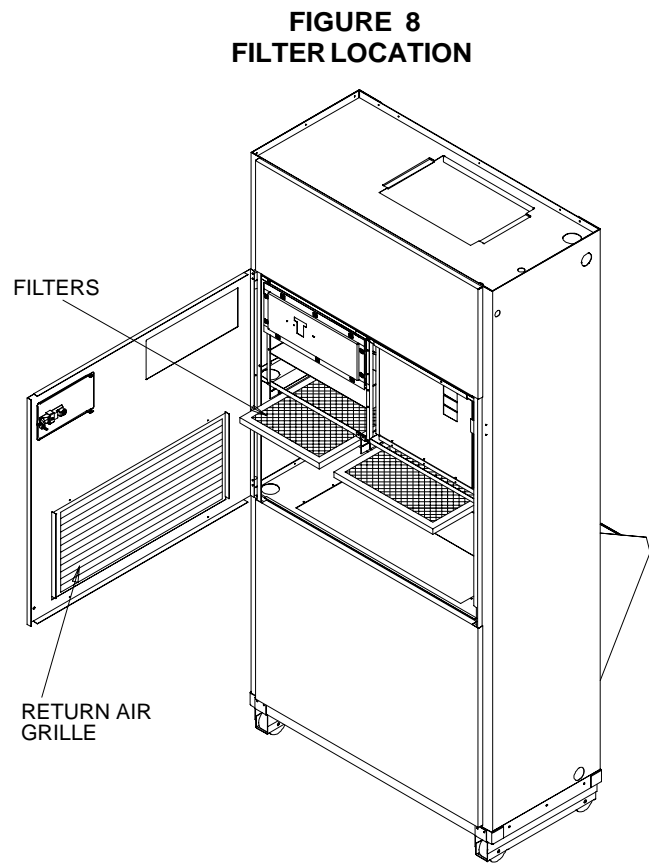

FRESH AIR INTAKE

This unit is equipped with a fresh air damper assembly. The damper blade is locked in the closed position when the unit is shipped from the Factory. To allow the damper to operate remove the two plastic locking pins, one on each end of the blade. This will allow for maximum fresh air flow. The Damper blade will now open when the indoor blower is operating. If less than maximum fresh air flow is required, reinsert the plastic pins to limit damper blade opening to desired level. Two extra pins are provided (taped to the inside of the assembly) which may be used to hold the blade in some position other than minimum or maximum position. This fresh air assembly is located in the rear of the unit and to gain access to make these adjustments remove the air filter service door.

All capacity, efficiency and cost of operation information as required for Department of Energy "Energyguide" Fact Sheets are based upon the fresh air blank-off plate in place and is recommended for maximum energy efficiency.

The blank-off plate is available upon request from the factory and is installed in place of the fresh air damper shipped with each unit.

For details on energy recovery ventilation see separate section.

CONDENSATE DRAIN

There are two drain connections on the unit. The rear drain is the primary drain, and is located on the right lower rear panel of the unit. The optional side drain is located on the bottom right side of the unit. The side drain is shipped with a plug installed.

The *side drain* requires a water trap for proper drainage. See Figure 9. The drain can be routed through the floor or through the wall. ***If the drain is to be routed through an unconditioned space, it must be protected from freezing.*** The drain line must be able to be removed from the unit if it is necessary to remove the unit from the wall.

The *rear drain* can be used with wall thickness of up to 10 inches where a water trap can be installed between the unit and the interior wall. See Figure 10. The trap cannot extend beyond the edge of the unit or it will interfere with the wall mounting bracket. When the rear drain is used, the plug must be removed and installed in the side drain. The drain can be routed through the floor or through the wall. If the drain is routed through the wall, the drain line must be positioned such that it will not interfere with the sleeve flange or the grille. See Figure 11. ***If the drain is to be routed through an unconditioned space, it must be protected from freezing.***

Optional rear drain kits, both standard and heated versions, are available to facilitate easy installation, and also removability of heat pump for service.

**FIGURE 9
SIDE DRAIN (SIDE VIEW)**

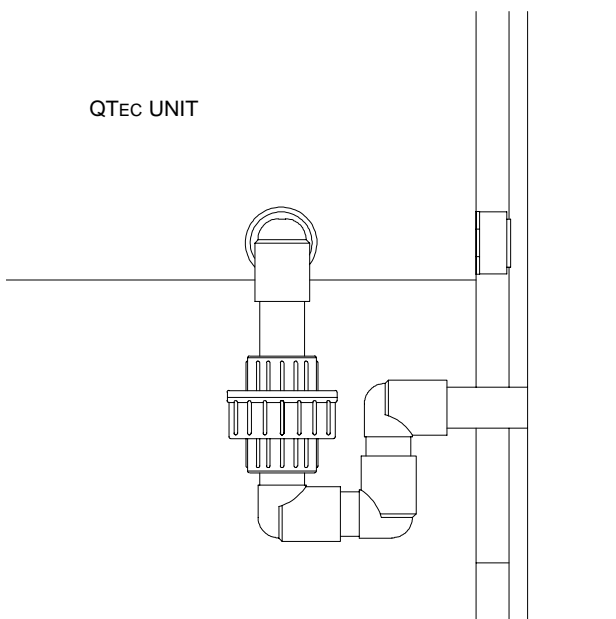

MIS-976

**FIGURE 10
OPTIONAL REAR DRAIN**

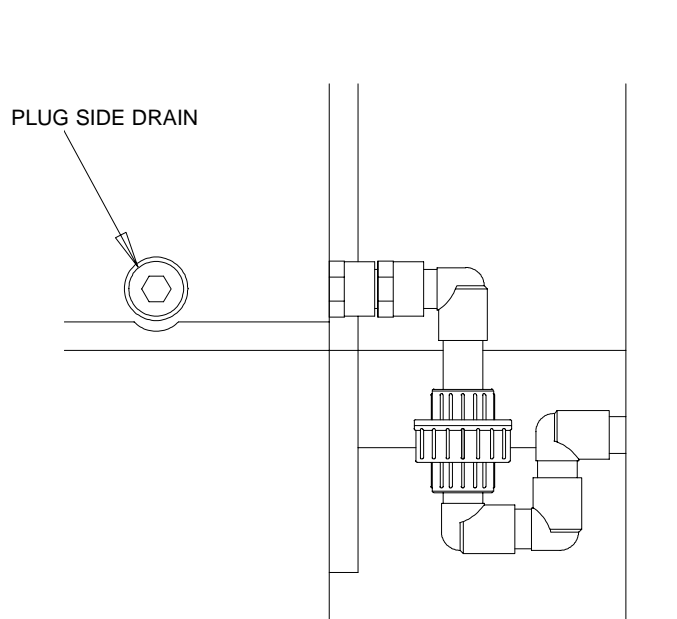

MIS-975

**FIGURE 11
REAR DRAIN (TOP VIEW)**

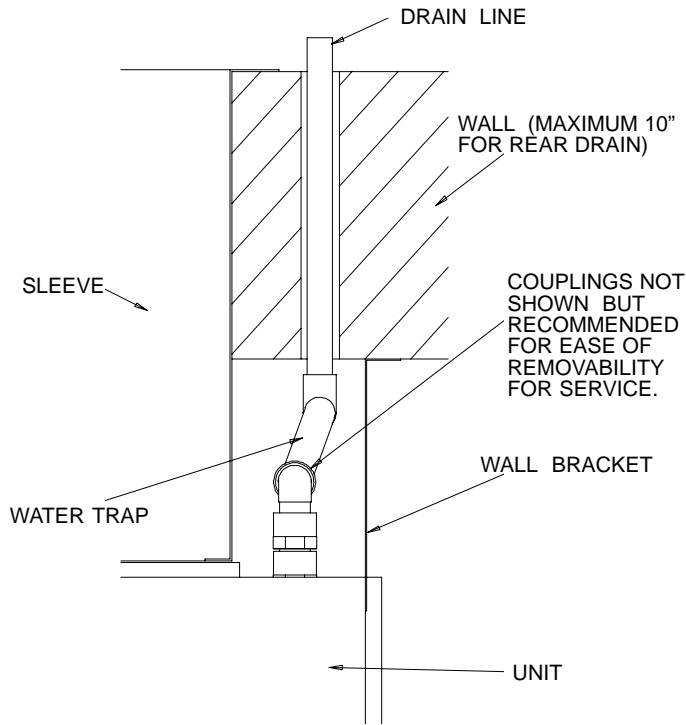

MIS-977

SERVICE LIGHT

The unit is equipped with a service light which signals the user that service is required. The light is located in the upper control panel and is visible only when the hinged service/filter access door is open.

The *Service Unit* light indicates that the unit has been shut off by a high or low pressure device. This indicates that the unit needs to be serviced.

**FIGURE 12
UNIT MOUNTING**

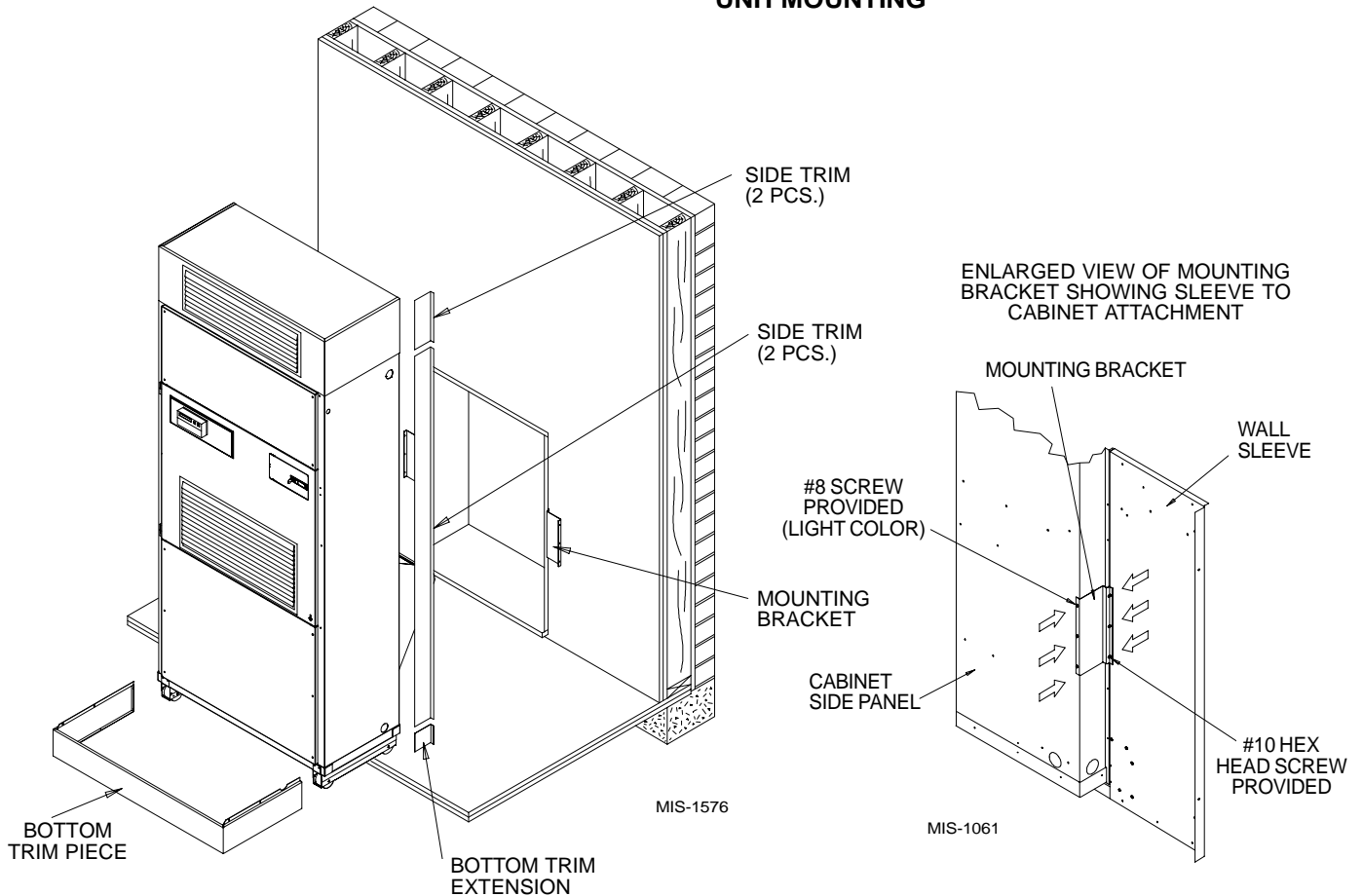

INSTALLATION INSTRUCTIONS

MOUNTING THE UNIT

When installing a QTEC unit near an interior wall on the left side, a minimum of 8 inches is required; 12 inches is preferred.

When installing a QTEC unit near an interior wall on the right side, a minimum of 18 inches is required as additional space is required to connect the side drain. If the rear condensate drain kit QCDS48 is used the minimum can be reduced to 8 inches.

This clearance is required to allow for the attachment of the unit to the sleeve and side trim pieces to the wall.

This unit is to be secured to the wall sleeve with mounting brackets provided. The unit itself, the supply duct and the free blow plenum are suitable of "0" clearance to combustible material.

Following are the steps for mounting the QTEC, for reference see Figure 12 (page 11).

1. Attach mounting brackets to the wall sleeve with screws provided.
2. Position the unit in front of the sleeve with the condenser section toward the sleeve.
3. Remove the locking screws from the wheels. Refer to Figure 13.
4. Roll the unit into the sleeve. Make sure to check both sides of the unit as it is being rolled to keep it centered in the sleeve. Also check the

alignment to the mounting brackets. This unit must be level from side to side. If adjustments are necessary, shim up under the rollers with sheets of steel or any substance that is not affected by moisture.

5. Make sure the gasket on the rear of the unit is touching the sleeve across the top and down both sides. This is a rain water seal.
6. Secure the mounting brackets to the unit with screws provided, #10 hex head sheet metal screws.
7. Bottom trim extensions are provided for use when wall is less than 14 inches but greater than 10.5 inches. Secure to wall with screws (not provided).
8. Attach the bottom trim piece to the unit with the screws provided (dark colored).
9. Position side trim pieces to wall and attach with field supplied screws. There are two long pieces and two short pieces supplied. The long pieces are to enclose the gap behind the unit. The short pieces are to fill the gap behind the cabinet extension or the free blow plenum box. The may be cut to suit your ceiling height or overlap the unit side trim. There is sufficient length to trip up to a 10'2" ceiling.

NOTE: If the exterior wall thickness is between 5 inches to 10.5 inches, a side trim extension piece kit, model QSTX42, is available.

**FIGURE 13
REMOVING LOCKING SCREWS FROM WHEELS**

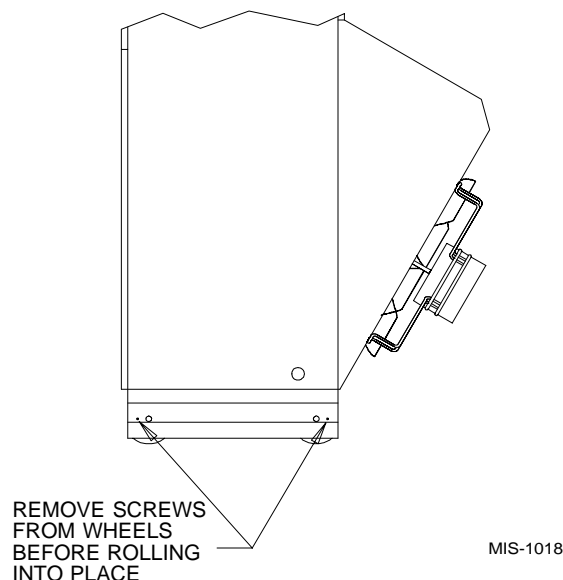

WIRING – MAIN POWER

Refer to the unit rating plate and/or Table 2 for wire sizing information and maximum fuse or “HACR Type” circuit breaker size. Each unit is marked with a “Minimum Circuit Ampacity”. This means that the field wiring used must be sized to carry that amount of current. Depending on the installed KW of electric heat, there may be two field power circuits required. If this is the case, the unit serial plate will so indicate. All models are suitable only for connection with copper wire. Each unit and/or wiring diagram will be marked “Use Copper Conductors Only”. These instructions **MUST BE** adhered to. Refer to the National Electrical Code (NEC) for complete current carrying capacity data on the various insulation grades of wiring material. All wiring must conform to NEC and all local codes.

The electrical data lists fuse and wire sizes (75° C copper) for all models, including the most commonly used heater sizes. Also shown are the number of field power circuits required for the various models with heaters.

The unit rating plate lists a “Maximum Time Delay Relay Fuse” or “HACR Type” circuit breaker that is to be used with the equipment. The correct size must be used for proper circuit protection, and also to assure that

there will be no nuisance tripping due to the momentary high starting current of the compressor motor.

The disconnect access door on this unit may be locked to prevent unauthorized access to the disconnect.

See Start Up section for information on three phase scroll compressor start-ups.

The field wiring connections are located behind the top and hinged panel in the circuit breaker panel. See Figure 14.

WIRING – LOW VOLTAGE WIRING

230/208V, 1 PHASE AND 3 PHASE EQUIPMENT DUAL PRIMARY VOLTAGE TRANSFORMERS.

All Equipment leaves the factory wired on 240V tap. For 208V operation, reconnect from 240V to 208V tap. The acceptable operating voltage range for the 240 and 208V taps are as noted in Table 3.

**TABLE 3
OPERATING VOLTAGE RANGE**

TAP	RANGE
240V	253 – 216
208V	220 – 187

NOTE: The voltage should be measured at the field power connection point in the unit and while the unit is operating at full load (maximum amperage operating condition).

The standard Climate Control **Option X** is a remote thermostat connection terminal block. See Figure 16 for wiring diagram. Compatible thermostats are listed in Table 4.

The Climate Control **Option A** is an electronic, non-programmable manual or auto changeover thermostat. The subbase of the thermostat is factory wired to the front panel of the unit. See Figure 17 for wiring diagram. Compatible for use with Bard CS2000 Controller and Energy Recovery Ventilator.

The Climate Control **Option D** is an electronic, programmable thermostat. The subbase of the thermostat is factory wired to the front panel of the unit. See Figure 18 for wiring diagram. Compatible for use with Energy Recovery Ventilator or Economizer.

**FIGURE 14
COMPONENT LOCATION**

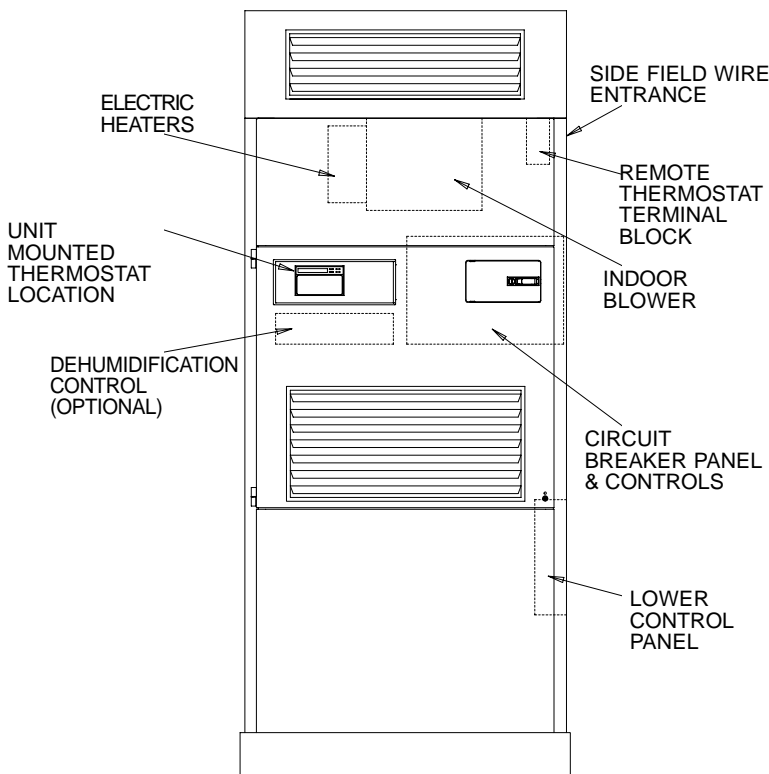

MIS-1577

LOW VOLTAGE CONNECTIONS

These units use a grounded 24 volt AC low voltage circuit.

The “R” terminal is the *hot* terminal and the “C” terminal is *grounded*.

“G” terminal or pins 6 and 1 of P2 are the *fan inputs*. **Both must be energized** for proper fan operation. This is done automatically in the factory installed climate control options. If the climate control option is abandoned and connections are made directly to P2 both pins 6 and 1 of P2 must be energized for proper operation.

“Y” terminal or pin 7 of P2 is the *compressor input*.

“B” terminal or pin 8 of P2 is the *reversing valve input*. The reversing valve must be energized for heating mode.

“R” terminal or pin 10 of P2 is *24 VAC hot*.

“C” terminal or pin 11 of P2 is *24 VAC grounded*.

“L” terminal or pin 12 of P2 is *compressor lockout output*. This terminal is activated on a high or low pressure trip by the electronic heat pump control. This is a 24 VAC output.

“W2” terminal or pin 9 of P2 is *second stage heat* (if equipped). If the unit is equipped with an optional hot water coil plenum box or electric heat these will be energized by this terminal.

“O1” terminal of pin 5 of P2 is the *ventilation input*. This terminal energizes any factory installed ventilation option.

“E” terminal or pin 3 of P2 is the *emergency heat input*. This terminal energizes the emergency heat relay.

NOTE: For total and proper control using DDC, a total of 6 controlled outputs are required (5 if no ventilation system is installed). For proper system operation under Emergency Heat conditions. Where the compressor needs to be deactivated, the B-W2-E outputs need to be energized. Removing the Y (compressor) signal alone turns the compressor off, but does not activate the additional circuitry embedded in the heat pump for proper and complete operation.

LOW VOLTAGE CONNECTIONS FOR DDC CONTROL

Fan Only	Energize G
Cooling Mode	Energize Y, G
Heat Pump Heating	Energize Y, G, B
2nd Stage Heating (if employed)	Energize G, W2
Ventilation	Energize G, O1
Emergency Heat	Energize B, W2, E

TABLE 4
WALL THERMOSTATS AND SUBBASE COMBINATIONS

Thermostat	Subbase	Predominant Features
8407-017 (T874R1129)	8404-009 (Q674L1181)	Heat or Cool No Auto
8403-018 (T874N2024)	8404-010 (Q6741261)	Automatic Heat/Cool Changeover Position
8403-034 (1F94-80)	N/A	Manual/Auto/Heat Cool Programmable Electronic
8403-042 (T8511G1070)	N/A	Manual/Auto/Heat/Cool Non-Programmable Electronic

FIGURE 15

**THERMOSTAT PLUG TERMINALS
P2 AND P4
(VIEWED FROM PIN END)**

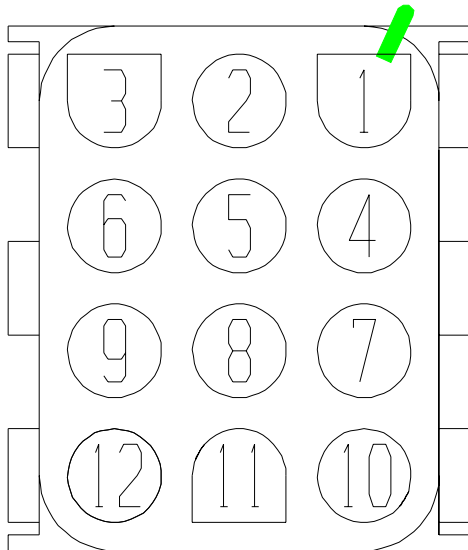

**BLOWER MOTOR
LOW VOLTAGE PLUG
(VIEWED FROM PIN END)**

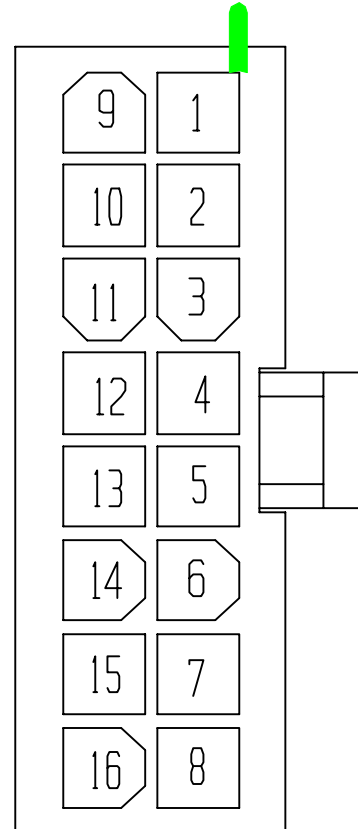

MIS-1285

**FIGURE 16
REMOTE THERMOSTAT WIRING DIAGRAM
"X" THERMOSTAT OPTION**

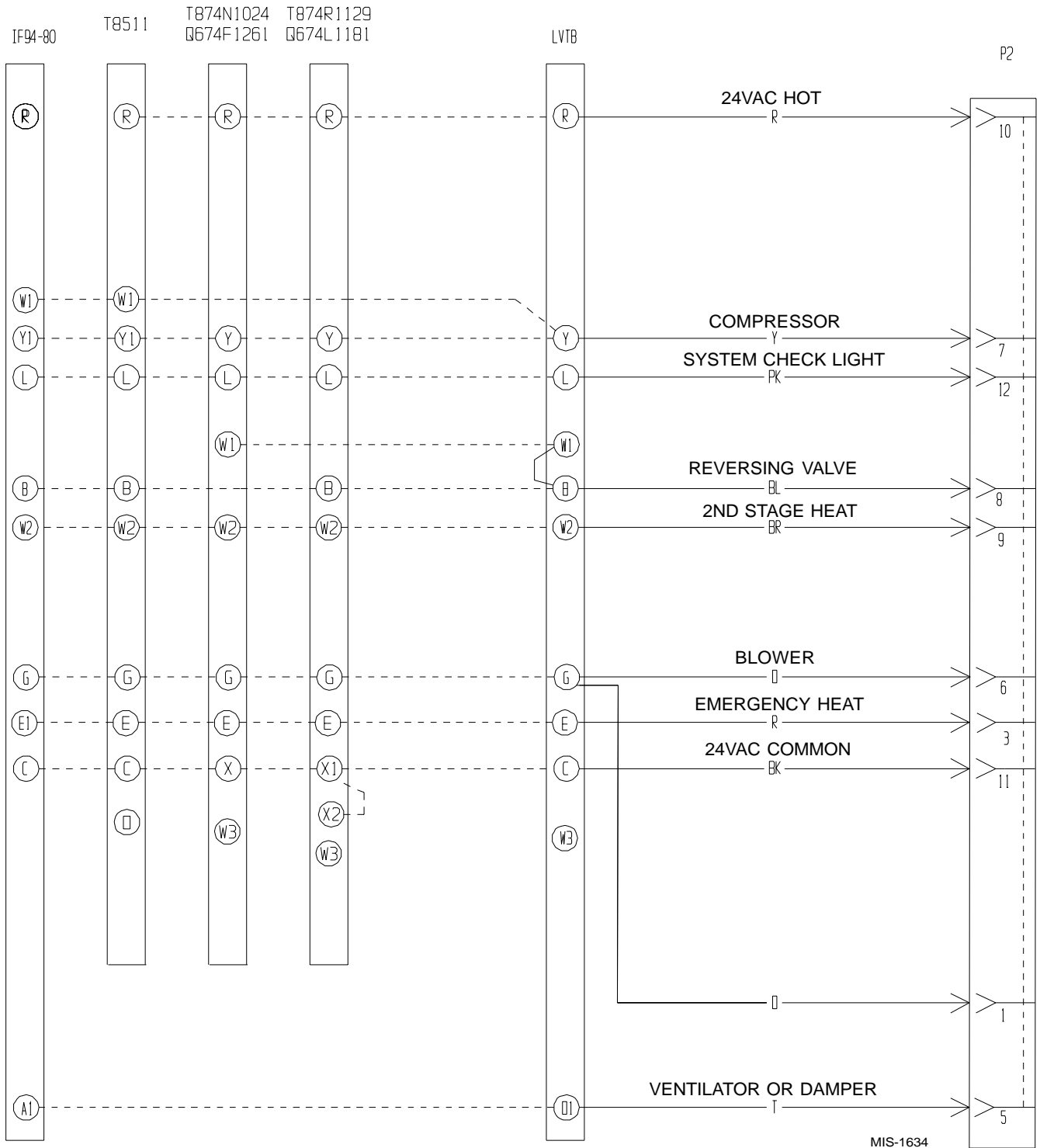
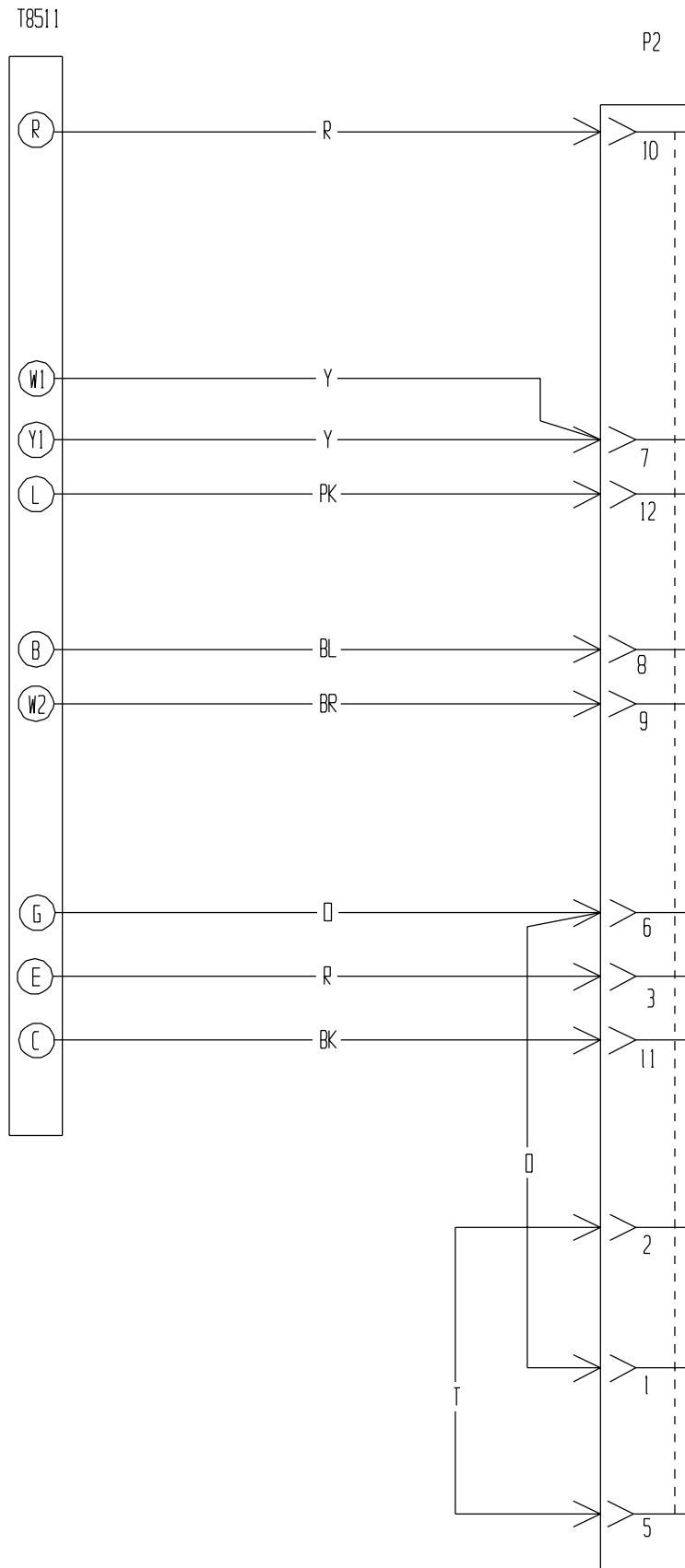
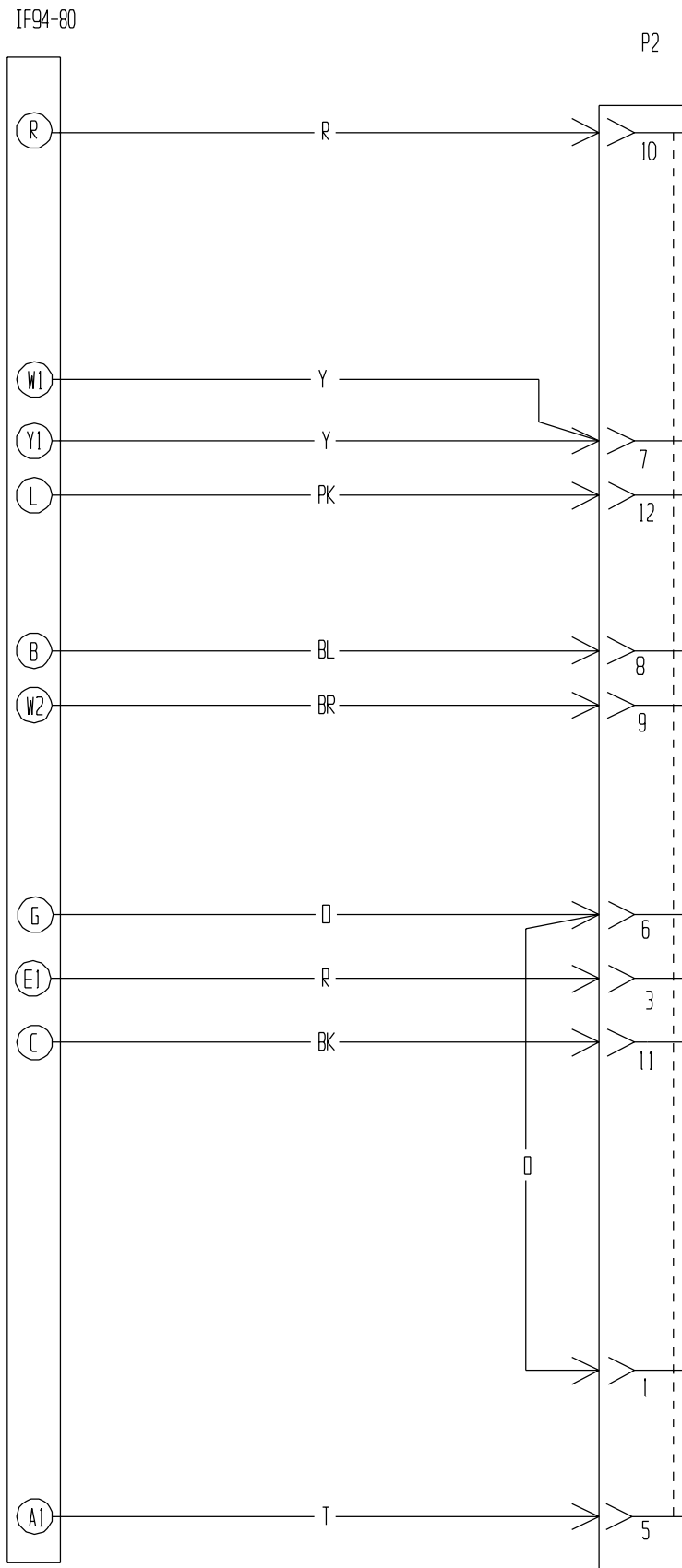

FIGURE 17
UNIT MOUNTED THERMOSTAT WIRING DIAGRAM
"A" THERMOSTAT OPTION



4102-021

**FIGURE 18
UNIT MOUNTED THERMOSTAT WIRING DIAGRAM
"D" THERMOSTAT OPTION**



4102-022

DESCRIPTION OF STANDARD EQUIPMENT

Solid State Electronic Heat Pump Control

Provides efficient 30 minute defrost cycle. A thermistor sensor and speed up terminal for service along with a 10 minute defrost override are standard on the electronic heat pump control.

High / Low Pressure Switch

Provides refrigerant circuit high pressure and loss of charge protection. Includes lockout circuit that is resettable from room thermostat.

Five Minute Compressor Time Delay

Provides short cycle protection for the compressor which extends compressor life. Built into the electronic heat pump control as standard.

Service Lights

One service light indicates when service is required.

- Check System – detects high or low pressure switch operation for compressor protection.

OPTIONAL CFM (QH362, QH422, QH482 AND QH602 ONLY)

These units are shipped from the factory set to operate at the optional CFM level shown in Table 9. This provides lower operating sound levels for non-ducted, free discharge applications. This CFM level will reduce the system capacity performance by approximately 2% at the same energy efficiency.

Rated CFM is required for ducted applications for maximum performance rating. To obtain full CFM on these models, connect jumper wire as follows:

1. Disconnect all power to the unit. Failure to do so may result in damage to the motor.
2. Open return air service panel
3. Open inner control panel cover
4. Locate low voltage terminal strip. There is a pink jumper wire with both ends attached to terminal marked “G2”. Move one end of this jumper to terminal “Y”.
5. Reverse steps to reassemble.

IMPORTANT INSTALLER NOTE

For improved start-up performance, wash the indoor coil with a dishwasher detergent.

PHASE MONITOR

All units with three phase scroll compressors are equipped with a 3 phase line monitor to prevent compressor damage due to phase reversal.

The phase monitor in this unit is equipped with two LEDs. If the Y signal is present at the phase monitor and phases are correct the green LED will light and the compressor contactor is allowed to energize.

If phases are reversed, the red fault LED will be lit and compressor operation is inhibited.

If a fault condition occurs, reverse two of the supply leads to the unit. Do not reverse any of the unit factory wires as damage may occur.

THREE PHASE SCROLL COMPRESSOR START UP INFORMATION

Scroll compressors, like several other types of compressors, will only compress in one rotational direction. Direction of rotation is not an issue with single phase compressors since they will always start and run in the proper direction.

However, three phase compressors will rotate in either direction depending upon phasing of the power. Since there is a 50-50 chance of connecting power in such a way as to cause rotation in the reverse direction, ***verification of proper rotation must be made.*** Verification of proper rotation direction is made by observing that suction pressure drops and discharge pressure rises when the compressor is energized. Reverse rotation also results in an elevated sound level over that with correct rotation, as well as, substantially reduced current draw compared to tabulated values.

Verification of proper rotation must be made at the time the equipment is put into service. If improper rotation is corrected at this time there will be no negative impact on the durability of the compressor. However, reverse operation for over one hour may have a negative impact on the bearing due to oil pump out.

All three phase scroll compressors used in the QTec series are wired identically internally. As a result, once the correct phasing is determined for a specific system or installation, connecting properly phased power leads to the same Fusite terminal should maintain proper rotation direction. The direction of rotation of the motor may be changed by reversing any two line connections to the unit.

SERVICE HINTS

1. Caution user to maintain clean air filters at all times. Also, not to needlessly close off supply air registers. This may reduce air flow through the system, which shortens equipment service life as well as increasing operating costs and noise levels.
2. Switching to heating cycle at 75°F or higher outside temperature may cause a nuisance trip of the remote reset high pressure switch. Turn thermostat off, then on to reset the high pressure switch.
3. The heat pump wall thermostats perform multiple functions. Be sure that all function switches are correctly set for the desired operating mode before trying to diagnose any reported service problems.
4. Check all power fuses or circuit breakers to be sure they are the correct rating.
5. Periodic cleaning of the outdoor coil to permit full and unrestricted airflow circulation is essential.
6. Some service requires the need to remove the unit from the wall including replacement of the indoor coil and/or the outdoor coil. Also servicing the outdoor fan motor or fan blade will require removing the unit from the wall if the unit is installed at a height that is not easily accessible from the outside of the building.

In order to remove the unit from the wall the following procedure must be used:

- a. Turn off power to the unit at the remote location. Some units may have more than one power supply.
- b. Disconnect field wiring at unit terminal block and remove from unit.
- c. Disconnect condensate drain.
- d. Remove the lower skirting around the unit.
- e. Remove wall mounting brackets from wall on each side of the unit.
- f. If unit is attached to duct work, remove upper cabinet extension by removing the top center screw only from the cabinet side panel.
- g. Remove screws that attach the duct work to the unit flanges.
This unit is equipped with four rollers mounted to the base. For ease of pulling unit out from the wall, you may want to remove the bottom service door which requires removal of the return air panel, and grip the front flange of the base pan then pull straight out.

7. Annual maintenance is required to make sure that all of the systems are functioning properly.
 - a. Check to make sure that the drains are not obstructed in any way.
 - b. Remove any debris in the condenser section of the unit.
 - c. Inspect and clean mist eliminator as described below.
 - d. Inspect and wash outdoor coil as necessary.

MIST ELIMINATOR SERVICE

A mist eliminator is supplied with the wall sleeve. The mist eliminator is constructed of an aluminum frame and mesh. The mist eliminator is located in the top section of the wall sleeve and can be removed from the inside of the building without removing the unit from the wall. This requires that the ventilation package must be removed.

It is recommended that the mist eliminator be inspected annually and serviced as required. The mist eliminator can be inspected from the outside of the building by looking through the outdoor grille. The mist eliminator can be serviced from the outside by using a vacuum cleaner. The outdoor grille must be removed. Use the vacuum to remove dirt and debris from the surface of the mist eliminator. If additional cleaning is required, the mist eliminator will have to be removed from the sleeve.

The ventilation package will have to be removed to gain access to the mist eliminator. If the blank off plate option is used, it is not necessary to service the mist eliminator. The steps necessary to remove each of the vent options are listed on the following pages.

The mist eliminator can be cleaned by washing with soap and water. The excess water should be shaken off the mist eliminator before it is reinstalled.

VENT OPTIONS

BAROMETRIC FRESH AIR DAMPER (Standard)

Before starting, make sure the power has been turned off. The return air grille panel must be removed. The fresh air damper assembly can be seen on the back of the unit. See Figure 19.

1. The fresh air damper is attached to the back of the unit with one screw on either side of the assembly. Both of the screws must be removed.
2. Once the mounting screws are removed, tilt the assembly down and lift it out.

The mist eliminator can be seen through the opening. The mist eliminator must be raised up and the bottom can be pulled toward the front of the unit.

COMMERCIAL ROOM VENTILATOR (Option)

Before starting, make sure the power has been turned off. The return air grille panel must be removed. The commercial room ventilator (CRV) can be seen after the panel has been removed. The CRV must be removed to gain access to the mist eliminator.

1. The two mounting screws in the front of the CRV must be removed.
2. The power connectors for the CRV (located on the right side of the unit) must be disconnected. Squeeze the tabs on the sides of the connector and pull straight out. Unplug both of the connectors.
3. Slide the CRV straight out of the unit.

The mist eliminator can be seen through the opening in the back of the unit. The mist eliminator must be raised up and the bottom can be pulled toward the front of the unit and removed.

QTEC R ENERGY RECOVERY VENTILATOR (Option)

Before starting, make sure that the power has been turned off. The return air grille panel must be removed. The energy recovery ventilator (QERV) can be seen after the panel has been removed. To gain access to the mist eliminator, the QERV must be removed. See Figure 20.

1. The front fill plate of the QERV must be removed. There is one screw on either side of the plate. Remove these screws and remove the plate.
2. On either side of the QERV there are mounting screws that hold the QERV in place. Remove both of these screws.
3. Underneath the heat recovery cassette there is a power connector for the lower blower assembly. To disconnect this plug, the tabs on both sides of the plug must be squeezed to release the plug. While squeezing the tabs, pull the plug out of the socket.
4. The QERV is plugged into the unit in the right side of the unit. Both of these plugs must be disconnected to remove the QERV. Squeeze the tabs on the sides of the connector and pull straight out.
5. Slide the QERV assembly straight out of the unit, being careful not to let the cassette slide out of the QERV.

The mist eliminator can be seen through the opening in the back of the unit. The mist eliminator must be raised up and the bottom can be pulled toward the front of the unit and removed.

FIGURE 19
FRESH AIR DAMPER REMOVAL

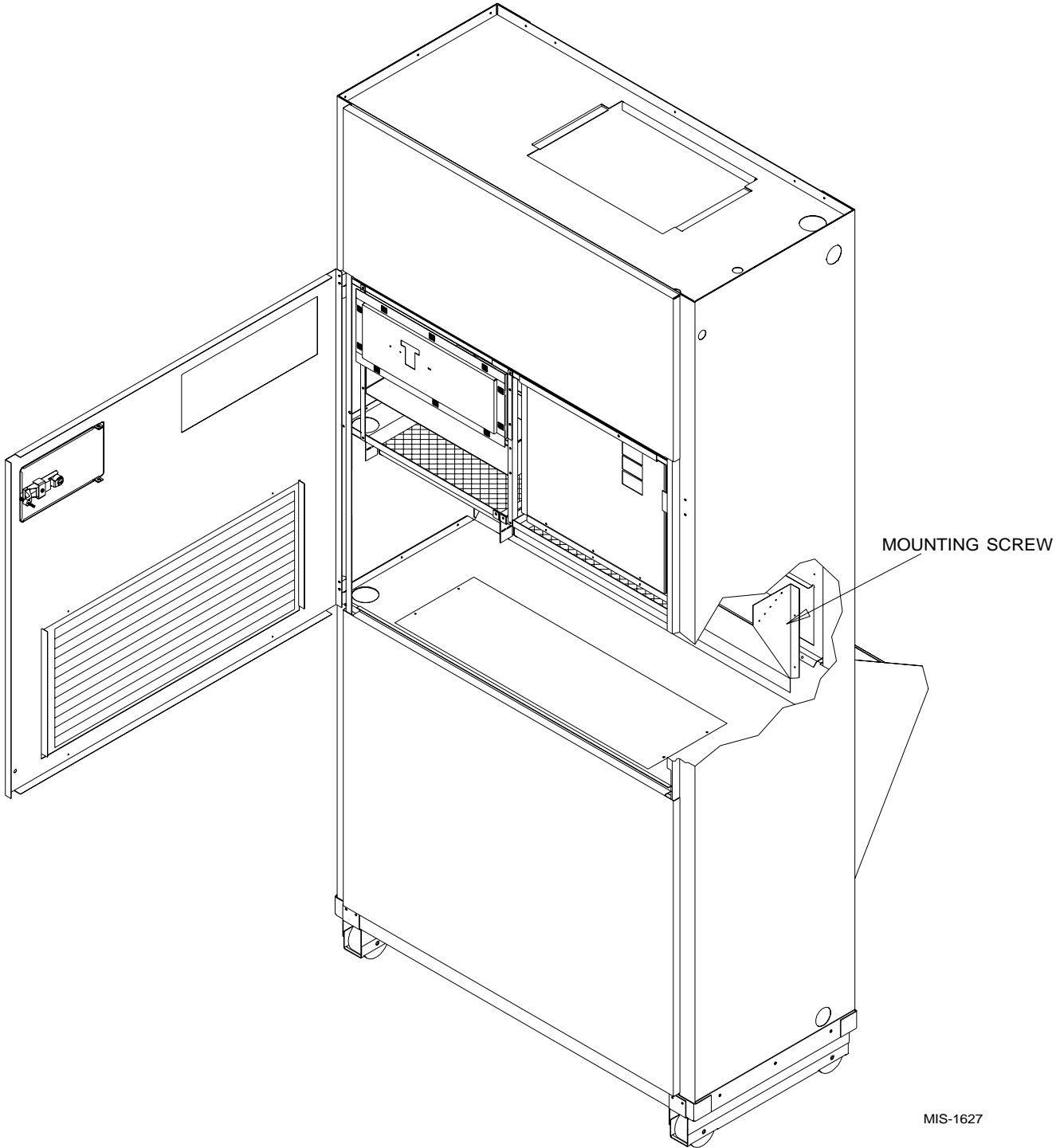

MIS-1627

**FIGURE 20
QERV REMOVAL**

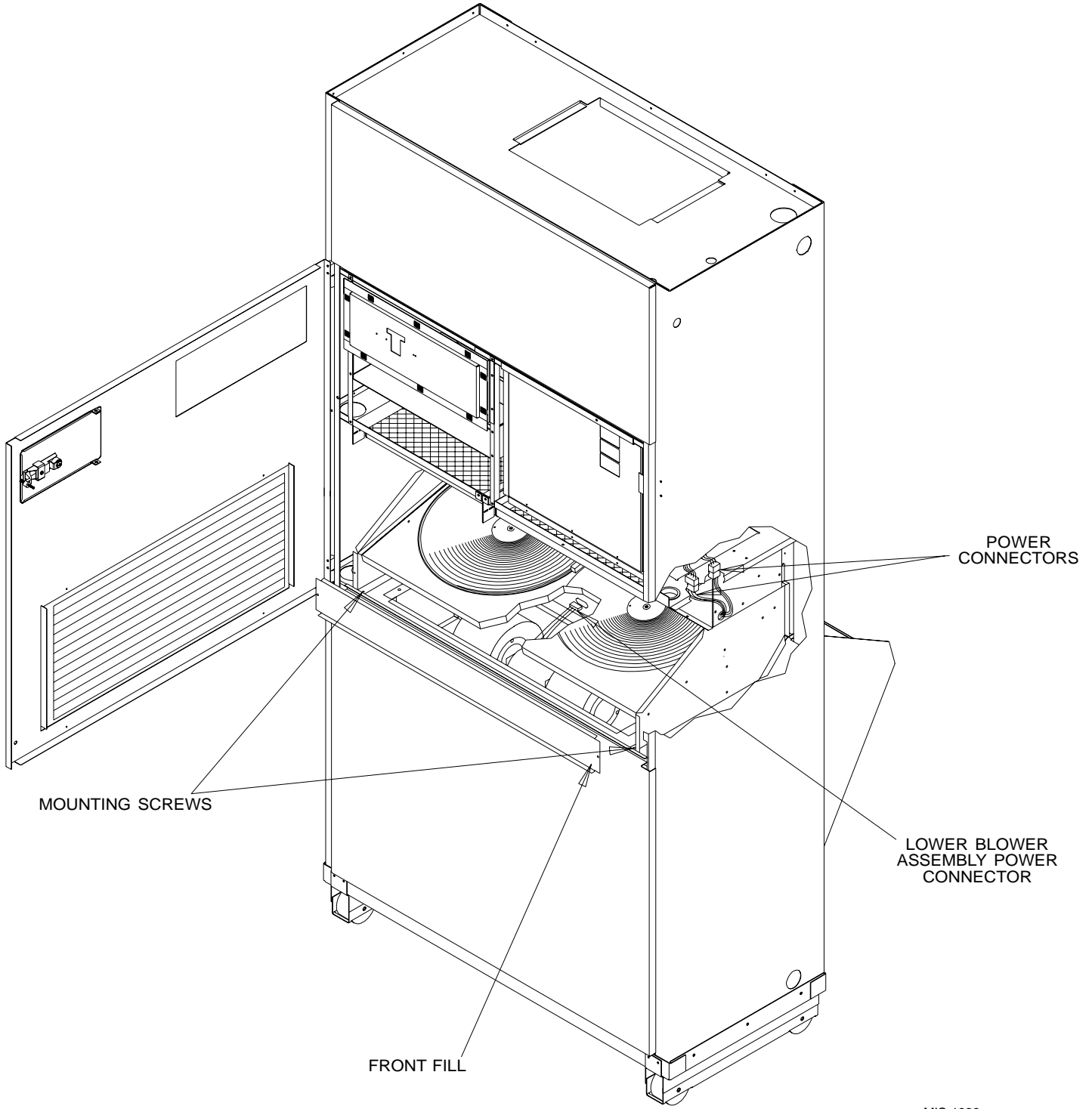

MIS-1039

SEQUENCE OF OPERATION

Cooling – Circuit R-Y makes the thermostat pull in the compressor contactor starting the compressor and outdoor motor. The G (indoor motor) circuit is automatically completed on any call for cooling operation, or can be energized by manual fan switch on subbase for constant air circulation.

Heating – A 24V solenoid coil on reversing valve controls heating cycle operation. Two thermostat options, one allowing “Auto” change over from cycle to cycle and the other constantly energizing solenoid coil during heating season and thus eliminating pressure equalization noise except during defrost, are to be used on “Auto” option, a circuit is completed for R-W1 and R-Y on each heating “on” cycle, energizing reversing valve solenoid and pulling in compressor contactor starting compressor and outdoor motor. R-G also makes starting indoor blower motor. Heat pump heating cycle now in operation.

The second option has no “Auto” change over position, but instead energizes the reversing valve solenoid constantly whenever the system switch on subbase is placed in “Heat” position, the “B” terminal being constantly energized from R. A thermostat demand for heat completes R-Y circuit, pulling in compressor contactor starting compressor and outdoor motor. R-G also make starting indoor blower motor.

High / Low Pressure control provides protection for the compressor. In the advent system pressures go above 450 PSI or below 3.5 PSI in either cooling or heating mode the compressor will be stopped. This will activate the red light located in the control panel. The lockout circuit will hold compressor off line. When the

system problem is corrected, the unit operation can be restored by turning of the main power supply off and then back on, or reset the room thermostat. The low pressure control has a bypass to eliminate nuisance lockout on cold start up.

OPTIONAL CLIMATE CONTROLS SEQUENCE OF OPERATION

The Climate Control Option A is an electronic, non-programmable manual or auto changeover thermostat. The thermostat may be manually set to heat or cool mode. The thermostat will maintain the temperature set on the thermostat in the mode in which it is set.

The Climate Control Option D is an electronic, programmable thermostat. The thermostat can be set in the heat, cool or automatic mode. When the thermostat is sent in the heat mode, it can heat only to maintain the temperature set on the thermostat. When the thermostat is set in the cool mode, it can cool only to maintain the temperature set on the thermostat. When the thermostat is set in the automatic mode, the thermostat can change automatically to the heat or cool modes to maintain the temperature set on the thermostat.

PRESSURE SERVICE PORTS

High and low pressure service ports are installed on all units so that the system operating pressures can be observed. Pressure curves can be found later in the manual covering all models on both cooling and heating cycles. It is imperative to match the correct pressure curve to the unit by model number. Upper and lower service doors must be attached to obtain proper reading.

**FIGURE 21
HEAT PUMP CONTROL BOARD (HPC)**

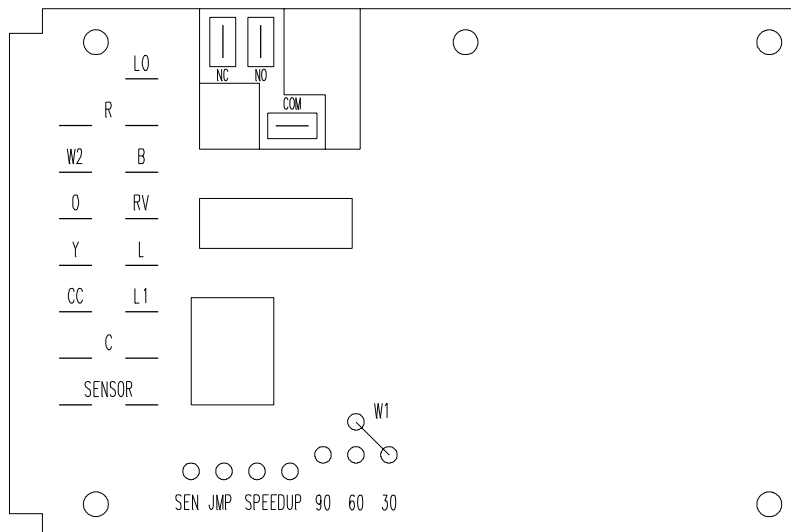

MIS-973

DEFROST CYCLE

The defrost cycle is controlled by temperature and time on the solid state heat pump control. (Refer to Figure 19.)

When the outdoor temperature is in the lower 40° F temperature range or colder, the outdoor coil temperature is 32° F or below. This coil temperature is sensed by the coil sensor mounted near the bottom of the outdoor coil. Once coil temperature reaches 30° F or below, the coil sends a signal to the control logic of the heat pump control and the defrost timer will start.

After 30 minutes at 30° F or below, the heat pump control will place the system in the defrost mode.

During the defrost mode the refrigerant cycle switches back to the cooling cycle, the outdoor motor stops, electric heaters are energized, and hot gas passing through the outdoor coil melts any accumulated frost. When the temperature rises to approximately 57° F, the coil sensor will send a signal to the heat pump control which will return the system to heating operations automatically.

If some abnormal or temporary condition such as a high wind causes the heat pump to have a prolonged defrost cycle, the heat pump control will restore the system to heating operation automatically after 10 minutes.

There are three settings on the heat pump control – 30 minute, 60 minute and 90 minute. Models are shipped wired on the 30 minute setting for greatest operating economy. If special circumstances require a change to another time, remove wire connected to terminal 30 and reconnect to desired terminal. Refer to Figure 21. The manufacturer's recommendation is for 30 minute defrost cycles.

There is a cycle speed up jumper on the control. This can be used to reduce the time between defrost cycle operation without waiting for time to elapse.

Use a small screwdriver or other metallic object, or another 1/4 inch QC, to short between the *SPEEDUP* terminals to accelerate the HPC timer and initiate defrost. Be careful not to touch any other terminals with the instrument used to short the *SPEEDUP* terminals. It may take up to 10 seconds with the *SPEEDUP* terminals shorted for the speedup to be completed and the defrost cycle to start.

As soon as the defrost cycle kicks in remove the shorting instrument from the SPEEDUP terminal. Otherwise the timing will remain accelerated and run through the 1- minute maximum defrost length sequence in a matter of seconds and will automatically terminate the defrost sequence.

There is an initial defrost jumper (sen jmp) on the control that can be used at any outdoor ambient during the heating cycle to simulate a 0° coil temperature. This can be used to check defrost operation of the unit without waiting for the outdoor ambient to fall into the defrost region.

By placing a jumper across the *SEN JMP* terminals (a 1/4 inch QC terminal works best) the defrost sensor mounted on the outdoor coil is shunted out and will activate the timing circuit. This permits the defrost cycle to be checked out in warmer weather conditions without the outdoor temperature having to fall into the defrost region.

In order to terminate the defrost test the *SEN JMP* jumper must be removed. If left in place too long the compressor could stop due to the high pressure control opening because of high pressure condition created by operating in the cooling mode with outdoor fan off. Pressure will rise fairly fast as there is likely no actual frost on the outdoor coil in this artificial test condition.

There is also a 5 minute compressor time delay function built into the HPC. This is to protect the compressor from short cycling conditions. In some instances it is helpful to the service technician to override or speed up this timing period, and shorting out the *SPEEDUP* terminals for a few seconds can do this.

TROUBLESHOOTING

**TABLE 5
TROUBLESHOOTING**

Symptom	Possible Cause	What to Check	How to Check or Repair
Compressor contactor does not energize (cooling or heating)	Control circuit wiring	Check for R connection at unit, and 24V between R-C.	Run R connection to outdoor unit to power heat pump control.
	Compressor lock out	1) Check for 24V between L1-C on heat pump control. 2) Check across high pressure switch.	1) If no voltage between L1-C turn thermostat off and on again to reset high pressure switch. 2) If high pressure switch is open and will not reset, replace high pressure switch.
	Compressor short cycle protection	Check for 24V between CC-C and Y-C on heat pump control.	If no voltage between CC-C jumper speed up terminal and within 10 seconds power should appear between CC-C. Remove speed up jumper after 10 seconds.
	Heat pump control defective	Check all other possible causes. Manual 2100-034	Replace heat pump control.
	Contactor defective	Check for open or shorted coil winding.	Replace contactor.
Fan outdoor motor does not run (cooling or heating except during defrost)	Motor defective	Check for open or shorted motor winding.	Replace motor.
	Motor capacitor defective	Check capacitor rating. Check for open or shorted capacitor.	Replace capacitor.
	Heat pump control defective	Check across fan relay on heat pump control (Com-NC)	Replace heat pump control.
	460V models only – outdoor motor relay defective	Check relay for 24V to relay coil when compressor contactor is energized, and that contacts are closing properly.	Replace relay.
Reversing valve does not energize (heating only)	Reversing valve solenoid coil defective	Check for open or shorted coil.	Replace solenoid coil.
	Heat pump control defective	Check for 24V between RV-C and B-C.	1) Check control circuit wiring. 2) Replace heat pump control
Unit will not go into defrost (heating only)	Temperature sensor or heat pump control defective	Disconnect temperature sensor from board, and jumper across speed up terminals and sen jmp terminals. This should cause the unit to go through a defrost cycle within one minute.	1) If unit goes through defrost cycle, replace temperature sensor. 2) If unit does not go through defrost cycle, replace heat pump control.
Unit will not come out of defrost (heating only)	Temperature sensor or heat pump control defective	Jumper across speed up terminals. This should cause the unit to come out of defrost within one minute.	1) If unit comes out of defrost cycle, replace temperature sensor. 2) If unit does not come out of defrost cycle, replace heat pump control.

SOLID STATE HEAT PUMP CONTROL TROUBLESHOOTING PROCEDURE

1. Turn on AC power supply to indoor and outdoor units.
2. Turn thermostat blower switch to “fan on” – the indoor blower should start. (If it doesn’t, troubleshoot indoor unit and correct problem.)
3. Turn thermostat blower to “auto” position. Indoor blower should stop.
4. Set system switch to “heat” or “cool”. Adjust thermostat to call for heat or cool. The indoor blower, compressor and outdoor fan should start.

NOTE: If there was no power to 24 volt transformer, the compressor and outdoor fan motor will not start for 5 minutes. This is because of the compressor short cycle protection.

CHECKING TEMPERATURE SENSOR

1. Disconnect temperature sensor from board and from outdoor coil.
2. Use an ohmmeter and measure the resistance of the sensor. Also use ohmmeter to check for short or open.
3. Check resistance reading to chart of resistance use sensor ambient temperature. (Tolerance of part is $\pm 10\%$.)
4. If sensor resistance reads very low, then sensor is shorted and will not allow proper operation of the heat pump control.
5. If sensor is out of tolerance, shorted, open, or reads very low ohms then it should be replaced.

**TABLE 6
TEMPERATURE (F) VS RESISTANCE (R) OF TEMPERATURE SENSOR**

F	R	F	R	F	R	F	R	F	R
-25.0	196871	5.0	72910	35.0	29986	65.0	13474	95.0	6531
-24.0	190099	6.0	70670	36.0	29157	66.0	13137	96.0	6383
-23.0	183585	7.0	68507	37.0	28355	67.0	12810	97.0	6239
-22.0	177318	8.0	66418	38.0	27577	68.0	12492	98.0	6098
-21.0	171289	9.0	64399	39.0	26823	69.0	12183	99.0	5961
-20.0	165487	10.0	62449	40.0	26082	70.0	11883	100.0	2827
-19.0	159904	11.0	60565	41.0	25383	71.0	11591	101.0	4697
-18.0	154529	12.0	58745	42.0	24696	72.0	11307	102.0	5570
-17.0	149355	13.0	56985	43.0	24030	73.0	11031	103.0	5446
-16.0	144374	14.0	55284	44.0	23384	74.0	10762	104.0	5326
-15.0	139576	15.0	53640	45.0	22758	75.0	10501	105.0	5208
-14.0	134956	16.0	52051	46.0	22150	76.0	10247	106.0	5094
-13.0	130506	17.0	50514	47.0	21561	77.0	10000	107.0	4982
-12.0	126219	18.0	49028	48.0	20989	78.0	9760	108.0	4873
-11.0	122089	19.0	47590	49.0	20435	79.0	9526	109.0	4767
-10.0	118108	20.0	46200	50.0	19896	80.0	9299	110.0	7663
-9.0	114272	21.0	44855	51.0	19374	81.0	9077	111.0	4562
-8.0	110575	22.0	43554	52.0	18867	82.0	8862	112.0	4464
-7.0	107010	23.0	42295	53.0	18375	83.0	8653	113.0	4367
-6.0	103574	24.0	41077	54.0	17989	84.0	8449	114.0	7274
-5.0	100260	25.0	39898	55.0	17434	85.0	8250	115.0	4182
-4.0	97064	26.0	38757	56.0	16984	86.0	8057	116.0	4093
-3.0	93981	27.0	37652	57.0	16547	87.0	7869	117.0	4006
-2.0	91008	28.0	36583	58.0	16122	88.0	7686	118.0	3921
-1.0	88139	29.0	35548	59.0	15710	89.0	7507	119.0	3838
0.0	85371	30.0	34545	60.0	15310	90.0	7334	120.0	3757
1.0	82699	31.0	33574	61.0	14921	91.0	7165	121.0	3678
2.0	80121	32.0	32634	62.0	14544	92.0	7000	122.0	3601
3.0	77632	33.0	31723	63.0	14177	93.0	6840	123.0	3526
4.0	75230	34.0	30840	64.0	13820	94.0	6683	124.0	3452

FAN BLADE SETTING DIMENSIONS

Any service work requiring removal or adjustment in the fan and/or motor area will require that the dimensions in Table 7 be checked and blade adjusted in or out of the motor shaft accordingly.

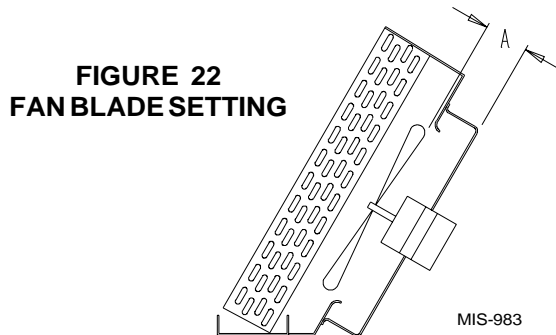

FIGURE 22
FAN BLADE SETTING

TABLE 7
FAN BLADE DIMENSIONS

MODEL	DIMENSION A (INCHES)
QH242	.750
QH302	.750
QH362	.750
QH422	.750
QH482	.750
QH602	.750

REFRIGERANT CHARGE

The correct system R-22 charge is shown on the unit rating plate. Optimum unit cooling performance will occur with a refrigerant charge resulting in a Super Heat as shown in Table 8. If correct charge is in doubt, recover the refrigerant and recharge per the charge on the unit rating plate.

TABLE 8
SUPER HEAT AT COMPRESSOR

MODEL	RATED CFM	95°F OD TEMPERATURE	82°F OD TEMPERATURE
QH242	800	16 - 18	14 - 16
QH302	1000	16 - 18	15 - 17
QH362	1200	16 - 18	14 - 16
QH422	1200	19 - 21	16 - 18
QH482	1400	23 - 25	22 - 24
QH602	1550	7 - 9	13 - 15

TABLE 9
INDOOR BLOWER PERFORMANCE

Model	Rated ESP	① Max. ESP	② Rated CFM	③ Optional CFM	④ Continuous CFM	CFM @ Max. ESP
QH242 ⑤	.10	0.5	800		800	700
QH302	.15	0.8	1000		1000	910
QH362	.15	0.8	1200	1000	1000	1175
QH422	.15	0.8	1200	1000	1000	1175
QH482	.15	0.8	1400	1100	1100	1175
QH602	.20	0.5	1550	1250	1250	1400

NOTE: These units are equipped with a variable speed (ECM) indoor motor that automatically adjust itself to maintain approximately the same rate of indoor air flow in both heating and cooling, dry and wet coil conditions and at both 230/208 or 460 volts.

- ① Maximum ESP (inches WC) shown is with 1" thick disposable filter (reduced by .2 for 2" filter).
- ② Rated CFM for ducted applications – required for maximum performance rating. To obtain full CFM on models QH362 and QH422, connect the pink jumper wire (provided) to terminal #5 and #6 on the low voltage terminal block located in the circuit breaker box.
- ③ Optional CFM – the unit is shipped from the factory set to operate at the optional CFM level shown. This provides lower operating sound levels for non-ducted, free discharge applications. This reduces system capacity performance by approximately 2% at the same energy efficiency.
- ④ Continuous fan CFM is the total air being circulated during continuous fan mode.
- ⑤ Models QH242 – when operating on 2nd stage heating the indoor air will increase to 1000 CFM.

**TABLE 10
COOLING PRESSURE
(ALL TEMPERATURES IN DEGREES F)**

MODEL	RETURN AIR TEMP.	PRESSURE	① AIR TEMPERATURE ENTERING OUTDOOR COIL								
			75	80	85	90	95	100	105	110	115
QH242	75 DB 62 WB	Low Side High Side	73 195	73 199	74 214	76 229	77 244	79 259	80 274	81 289	83 304
	80 DB 67 WB	Low Side High Side	78 203	78 204	79 219	80 234	82 250	84 264	85 280	87 296	88 312
	85 DB 72 WB	Low Side High Side	84 121	84 213	85 228	86 244	88 259	89 274	91 290	93 305	94 320
QH302	75 DB 62 WB	Low Side High Side	75 226	75 202	76 242	77 258	78 273	79 319	80 303	81 319	82 335
	80 DB 67 WB	Low Side High Side	80 228	80 233	81 248	82 264	83 280	84 296	85 311	86 327	87 343
	85 DB 72 WB	Low Side High Side	86 238	86 240	87 257	88 273	89 290	90 306	91 323	92 339	93 356
QH362	75 DB 62 WB	Low Side High Side	74 212	74 215	75 233	76 251	77 269	78 287	79 305	80 323	81 341
	80 DB 67 WB	Low Side High Side	79 219	79 220	80 239	81 257	82 276	83 294	84 312	85 331	86 350
	85 DB 72 WB	Low Side High Side	85 223	85 228	86 247	87 267	88 286	89 305	90 324	91 343	92 363
QH422	75 DB 62 WB	Low Side High Side	71 246	71 248	72 264	73 281	74 299	75 318	76 339	77 362	79 385
	80 DB 67 WB	Low Side High Side	75 251	76 243	77 270	78 288	79 307	80 327	81 349	82 371	83 395
	85 DB 72 WB	Low Side High Side	82 261	82 262	83 279	84 298	85 318	86 330	87 361	88 384	90 409
QH482	75 DB 62 WB	Low Side High Side	69 221	71 237	72 252	72 270	73 287	74 305	75 323	75 343	76 363
	80 DB 67 WB	Low Side High Side	75 228	76 244	76 260	77 276	78 294	79 312	80 331	80 351	81 372
	85 DB 72 WB	Low Side High Side	81 237	82 252	82 269	83 285	84 304	85 323	86 342	86 363	87 385
QH602	75 DB 62 WB	Low Side High Side	66 241	70 258	74 276	78 294	81 314	85 332	89 353	93 372	96 373
	80 DB 67 WB	Low Side High Side	71 247	75 265	79 283	83 302	87 322	91 341	95 362	99 382	103 403
	85 DB 72 WB	Low Side High Side	73 256	78 274	82 293	86 313	90 333	94 353	98 375	102 395	107 417

Low side pressure ± 2 psig
High side pressure ± 5 psig

Tables are based upon rated CFM (airflow) across the evaporator coil. If there is any doubt as to correct operating charge being in the system, the charge should be removed, system evacuated and recharged to serial plate instructions.

① 75° F outdoor temperature condenser fan motor is running on low speed.

**TABLE 11
HEATING PRESSURE
(ALL TEMPERATURES IN DEGREES F)**

MODEL	RETURN AIR TEMP.	PRESSURE	AIR TEMPERATURE ENTERING OUTDOOR COIL													
			0	5	10	15	17	20	25	30	35	40	47	50	55	60
QH242	70	Low Side	7	12	17	23	25	28	33	39	44	50	57	60	65	71
		High Side	147	155	164	172	176	181	189	198	206	215	227	232	240	249
QH302	70	Low Side	16	20	24	28	30	33	37	41	45	49	55	58	62	67
		High Side	157	163	169	175	177	180	187	193	199	205	213	217	222	228
QH362	70	Low Side	13	17	21	25	27	30	34	38	42	46	52	55	59	63
		High Side	147	153	159	164	167	171	176	182	188	194	202	206	211	217
QH422	70	Low Side	13	18	22	26	28	31	35	39	44	48	54	57	61	65
		High Side	161	168	174	180	183	187	193	199	206	212	221	225	231	237
QH482	70	Low Side	11	15	20	24	26	29	33	38	42	47	53	56	60	65
		High Side	154	160	167	173	176	180	186	192	199	206	215	219	225	232
QH602	70	Low Side	59	60	61	62	63	63	64	65	66	67	68	69	70	71
		High Side	156	162	168	175	177	181	188	194	200	207	216	220	226	233

Refer to notes following Table 10