

---

# INSTALLATION INSTRUCTIONS

## QW SERIES WALL SLEEVE

Model: QWVS42  
QWVS42-19

---

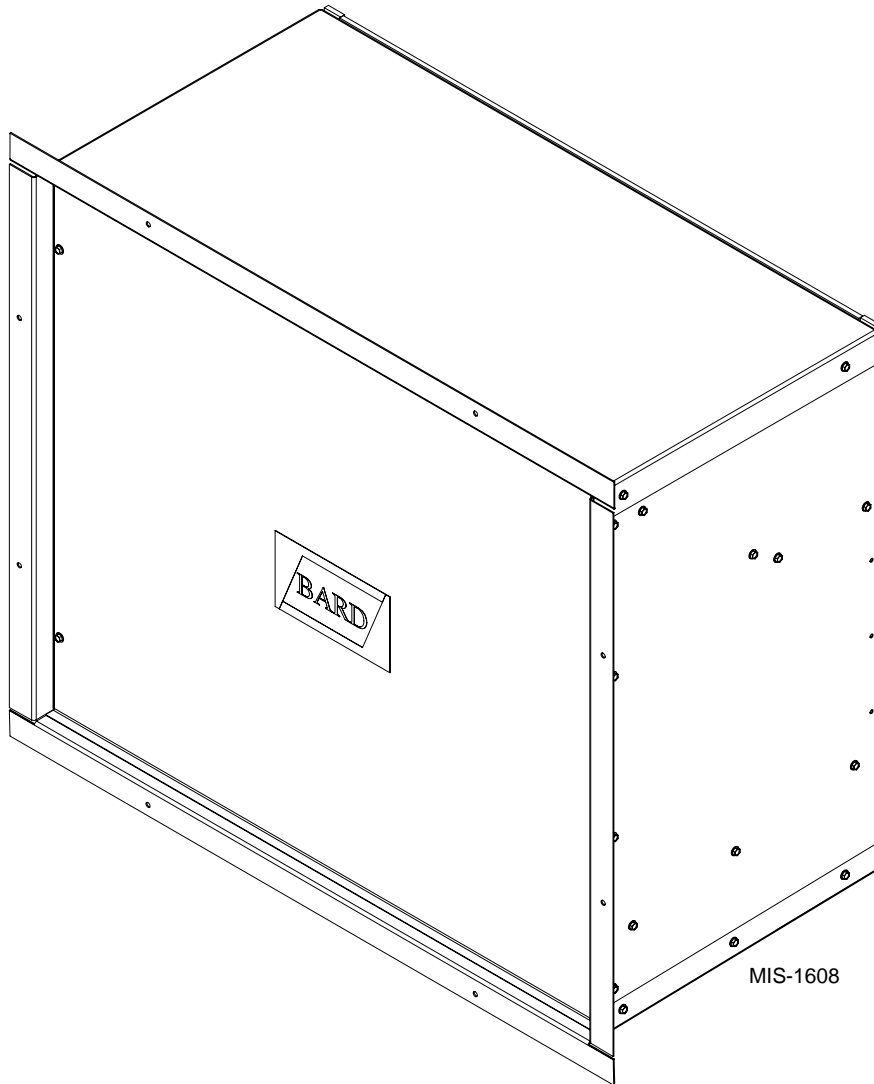

Bard Manufacturing Company, Inc.  
Bryan, Ohio 43506  
*Since 1914...Moving ahead, just as planned.*

Manual No.: 2100-383A  
Supersedes: 2100-383  
File: Vol. II Tab 14  
Date: 06-26-06

# CONTENTS

---

**Getting Other Information and Publications ..... 3**

**QW Series Wall Sleeve General Information**

Shipping Damage ..... 4

General ..... 4

**Installation Instructions**

Installation Wood Framed Walls ..... 4 & 6

Installation Masonry Construction Walls ..... 6 & 7

Installation Through Window Opening ..... 9

**Figures**

Figure 1 Wood Framed Installation ..... 4

Figure 2 Application of Sealant to Flanges ..... 5

Figure 3 Masonry Construction Installation ..... 6

Figure 4 Typical Installation ..... 7

Figure 5 Installation Through a Window Opening .. 8

# Getting Other Information and Publications

---

These publications can help you install the air conditioner or heat pump. You can usually find these at your local library or purchase them directly from the publisher. Be sure to consult current edition of each standard.

Standard for the Installation ..... ANSI/NFPA 90A  
of Air Conditioning and Ventilating Systems

Standard for Warm Air ..... ANSI/NFPA 90B  
Heating and Air Conditioning Systems

QW Installation Instruction Manual ..... Bard/2100-381

## FOR MORE INFORMATION, CONTACT THESE PUBLISHERS:

**ACCA**     **Air Conditioning Contractors of America**  
1712 New Hampshire Avenue, NW  
Washington, DC 20009  
Telephone: (202) 483-9370  
Fax: (202) 234-4721

**ANSI**     **American National Standards Institute**  
11 West Street, 13th Floor  
New York, NY 10036  
Telephone: (212) 642-4900  
Fax: (212) 302-1286

**ASHRAE**   **American Society of Heating, Refrigerating,  
and Air Conditioning Engineers, Inc.**  
1791 Tullie Circle, N.E.  
Atlanta, GA 30329-2305  
Telephone: (404) 636-8400  
Fax: (404) 321-5478

**BARD**     **Bard Manufacturing Company, Inc.**  
1914 Randolph Drive  
Bryan, OH 43506  
Telephone: (419) 636-1194  
Fax: (419) 636-2640

## SHIPPING DAMAGE

Upon receipt of equipment, the carton should be checked for external signs of shipping damage. If damage is found, the receiving party must contact the last carrier immediately, preferably in writing, requesting inspection by the carrier's agent.

## GENERAL

The QWVS42 Wall Sleeve is designed for use with QW Series Water to Air Heat Pumps where vent options are utilized. The QWVS42 is for use on installations where wall thickness is 14 inches or less. The QWVS42-19 is for use on installations where wall thickness is 16 inches or less.

The equipment covered in this manual is to be installed by trained service and installation technicians.

These instructions explain the recommended method to install the wall sleeve.

These instructions and any instructions packaged with any separate equipment required to make the entire air conditioning system should be carefully read before beginning the installation.

While these instructions are intended as a general recommended guide, they do not supersede any national and/or local codes in any way. Authorities having jurisdiction should be consulted before the installation is made.

## INSTALLATION – WOOD FRAMED WALLS

For wood frame construction walls, the dimensions of the opening must be 29.5 inches tall by 35 inches wide. A 2 x 6 header will be required for the opening. The sides of the opening must have trimmer studs to support the header, and to provide a structural member on which to fasten the sleeve. See Figure 1. All of the dimensions are referenced from the finished floor height.

Once the opening is framed, the sheeting can be installed, the sheeting material must not extend into the opening.

The sleeve should be test fit into the opening to make sure of the dimensions. The sleeve must be inserted into the opening from the outside of the building. The bottom of the sleeve must be level from side to side, and the sleeve must be square in the opening. A slope is built into the bottom of the sleeve from the inside to the outside. This will allow any water that gets into the sleeve to drain out. Once the test fit is completed, the sleeve must be removed from the opening, and a 1/4 inch bead of sealant must be applied to the mounting flanges of the sleeve. See Figure 2.

**FIGURE 1  
WOOD FRAMED INSTALLATION**

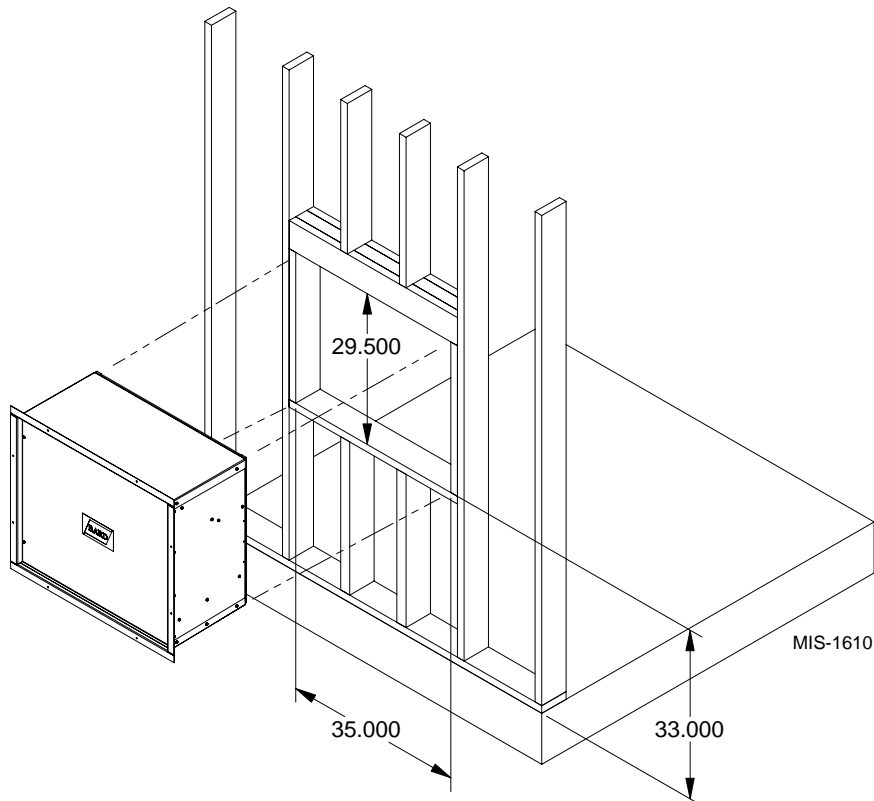

**FIGURE 2**  
**APPLICATION OF SEALANT TO FLANGES**

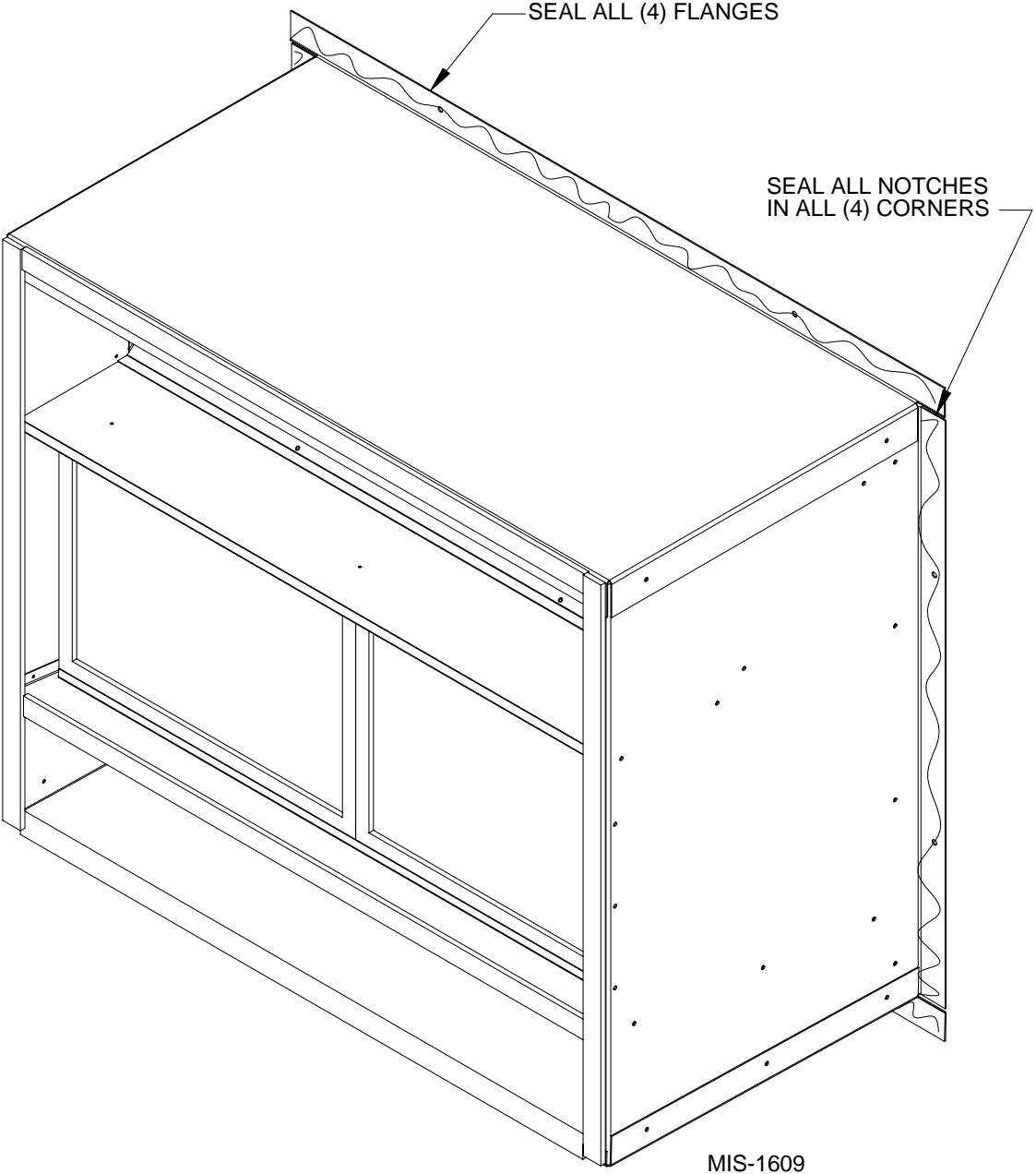

The sleeve is then reinserted into the prepared opening from the outside of the building. All of the mounting flanges must contact the exterior wall. Check to see that there is enough sealant to make this joint watertight. Additional sealant must be applied as necessary. The sleeve must be centered in the opening, and the bottom of the sleeve must be checked to make certain that it is level from side to side. The bottom flange should be secured to the wall by using two screws through the holes in the bottom mounting flange of the sleeve. The sleeve must be checked to make sure that it is square in the opening. Once the sleeve is square, the side and top mounting flanges of the sleeve must be secured to the wall with screws through the holes in the flanges. The gaps between the side flanges, and the top and bottom flanges must be filled with additional sealant.

On the inside of the building, the gaps between the sleeve and the opening must be filled with insulation. This will help insulate the sleeve and prevent infiltration of any unwanted outdoor air. See Figure 4.

There are two brackets supplied with the sleeve for attachment to the unit. Position these brackets to the sleeve and attach with three screws per side. Roll unit

up to sleeve making sure the cabinet rear is tight against the gasket on the sleeve flange to provide an air tight seal. Drill 1/8 diameter holes through the brackets into the cabinet side and attach with screws provided. See Figure 5 for more details.

## INSTALLATION – MASONRY CONSTRUCTION WALLS

For masonry construction walls, the dimensions for the opening will be 29.75 inches tall by 35.25 inches wide. These dimensions are plus or minus 1/4 inch and are measured from the finished floor height. See Figure 3. These will be the finish dimensions of the opening.

The sleeve should be test fit in the opening before final preparations are made. The sleeve will be installed into the opening from the outside of the building in. The sleeve must be centered in the opening from side to side. The mounting flanges of the sleeve must contact the outside wall all around the opening. The side and top mounting flanges must have the mounting holes drilled into the outside wall for the concrete anchors which will

**FIGURE 3  
MASONRY CONSTRUCTION INSTALLATION**

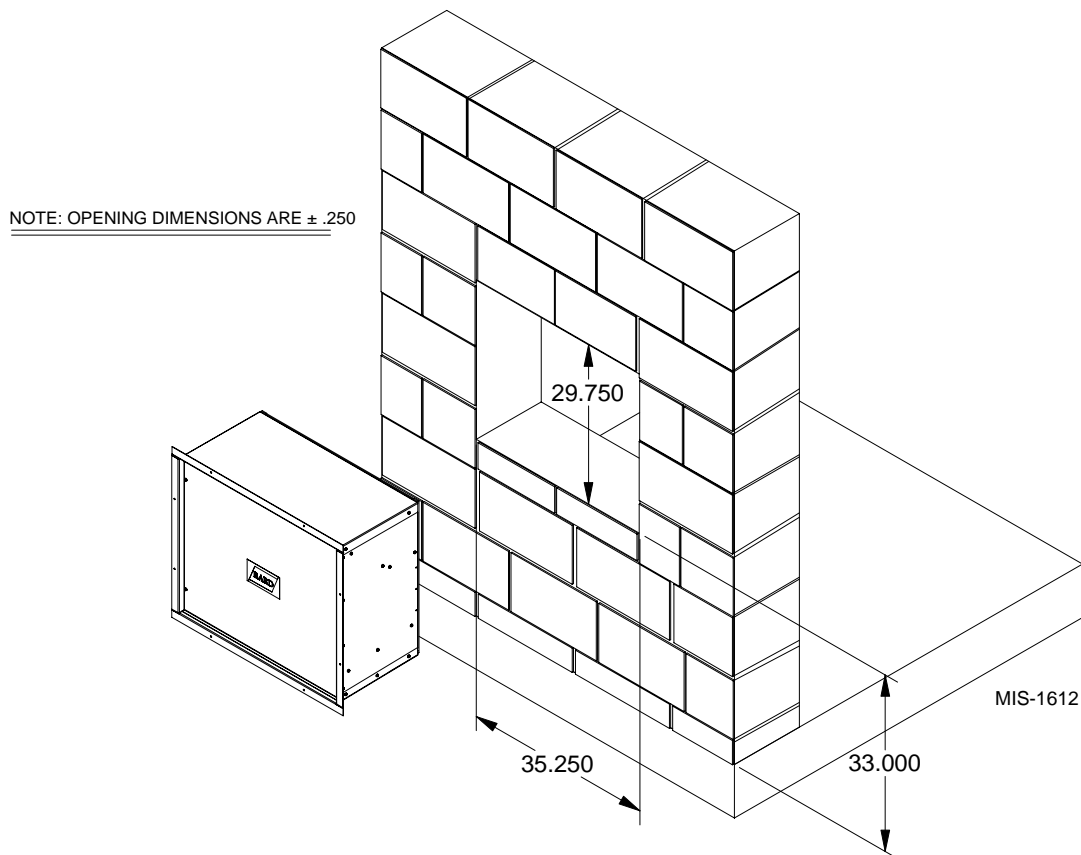

hold the sleeve in the wall. The holes should be drilled through the holes in the sleeve with the sleeve level and square in the opening. A slope is built into the bottom of the sleeve from the inside to the outside. This will allow any water that gets into the sleeve to drain out. Once the test fitting has been checked out, the sleeve should be removed from the wall.

With the sleeve removed, a 1/4 inch bead of sealant must be applied to the flanges that contact the outside wall. See Figure 2.

The sleeve must be installed back in the wall making sure that the predrilled holes in the wall line up with the holes in the mounting flanges of the sleeve. Check to make sure that there is enough sealant between the wall and the flanges to make the joint watertight. Additional sealant must be applied as required. The sleeve must be anchored to the wall. All four mounting flanges must be

fastened with two fasteners each to the outside wall. The gaps between the side flanges, and the top and bottom flanges must be sealed to the wall.

On the inside of the building, the gaps between the sleeve and the opening must be filled with insulation. This will help insulate the sleeve and prevent infiltration of any unwanted outdoor air. See Figure 4.

There are two brackets supplied with the sleeve for attachment to the unit. Position these brackets to the sleeve and attach with three screws per side. Roll unit up to sleeve making sure the cabinet rear is tight against the gasket on the sleeve flange to provide an air tight seal. Drill 1/8 diameter holes through the brackets into the cabinet side and attach with screws provided. See Figure 5 for more details.

**FIGURE 4  
TYPICAL INSTALLATION**

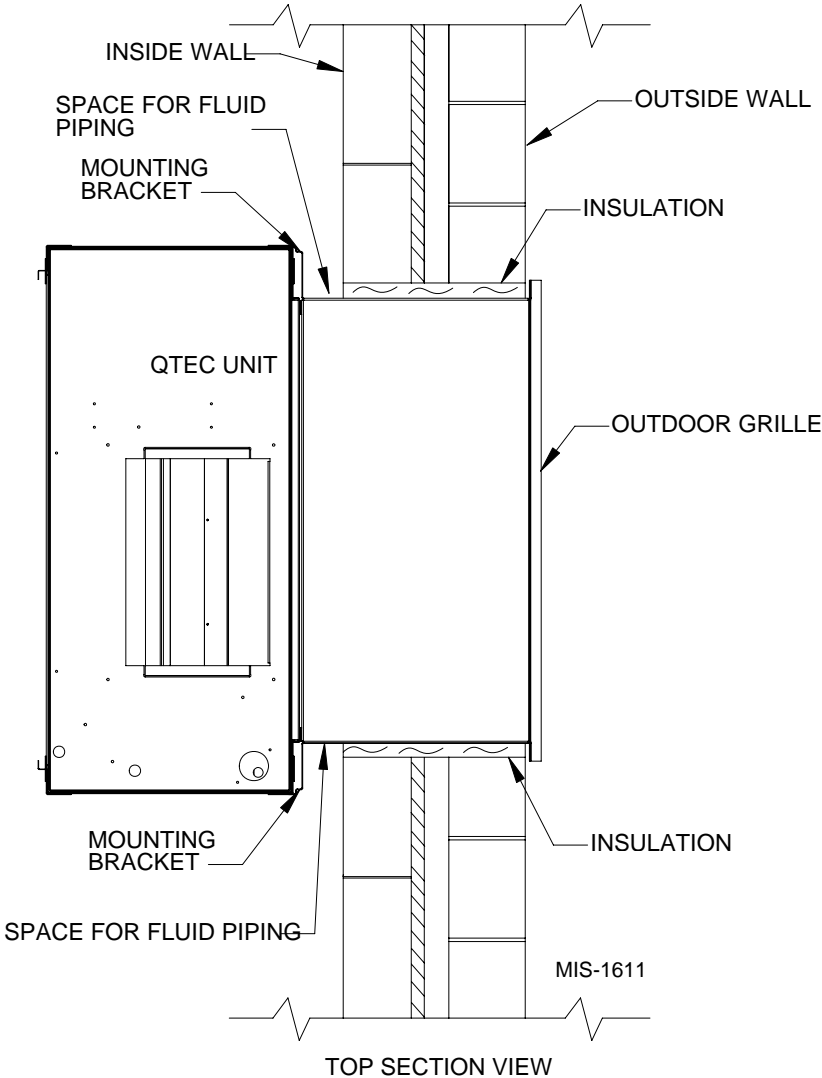

**FIGURE 5  
INSTALLATION OF QW WALL SLEEVE THROUGH A WINDOW OPENING**

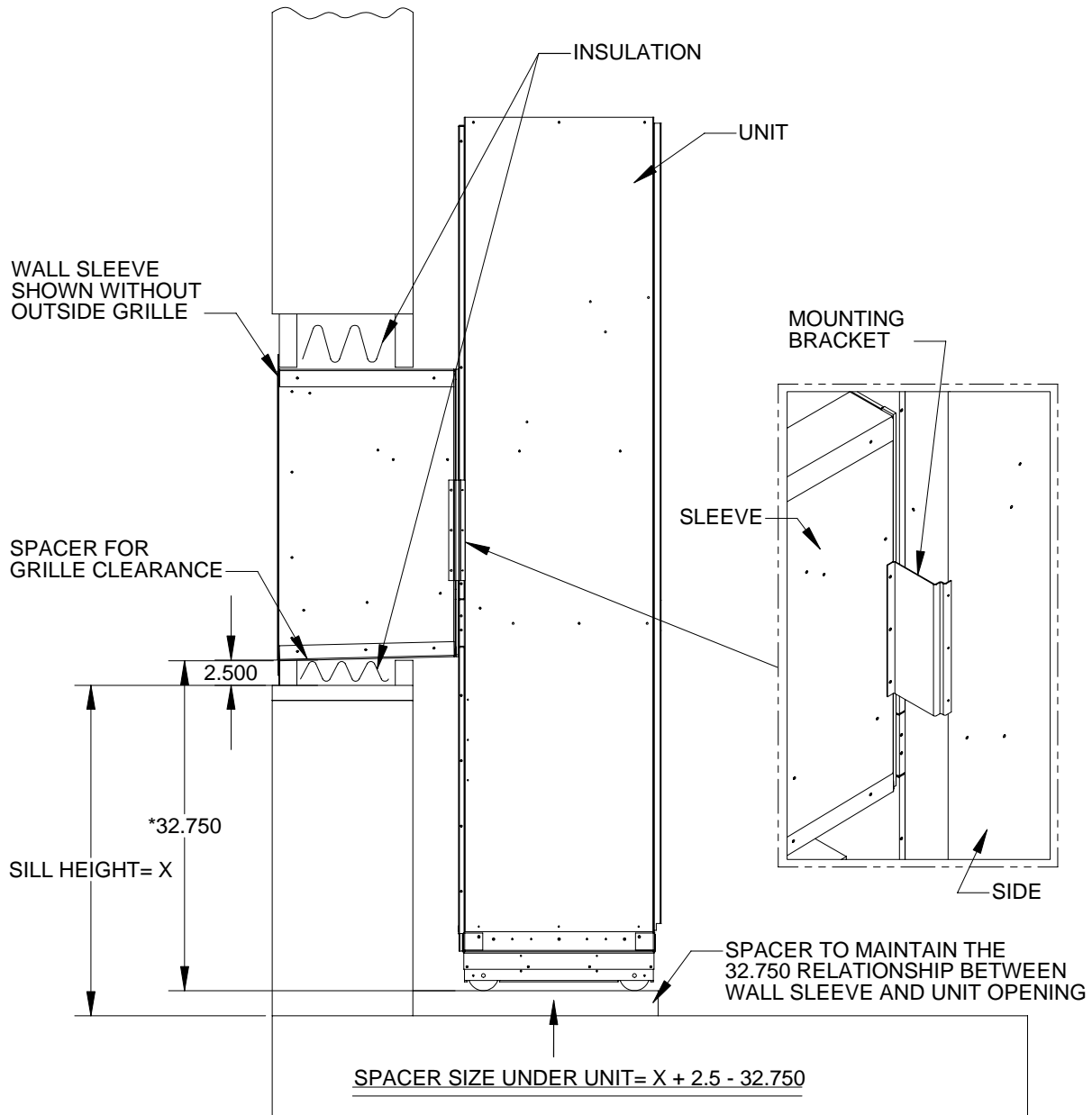

**\*THIS DIMENSION MUST REMAIN CONSTANT  
WHEN FABRICATING UNIT AND WALL SLEEVE  
REGARDLESS OF THE WINDOW SILL DIMENSIONS**

MIS-1614



## INSTALLATION THROUGH A WINDOW OPENING

*NOTE: Depending on the window sill height as measured from the inside finished floor, a spacer may be required under the unit wheels to insure the proper relationship from the bottom of the sleeve and the window sill. To determine the height of this spacer measure the window sill height from the finished floor, add 2.5 inches and subtract 32.75 inches. Example: with a sill height of 33 inches, add 2.5 inches and subtract 32.75 inches. This equals a spacer height of 2.75 inches. This spacer is to continue across the front of the unit to seal up the gap between the floor and the bottom trim piece. When the unit is placed on these spacers the locking screws must be driven back into the wheel to secure the unit's position. Also, there are two brackets supplied with the sleeve to secure the sleeve to the unit. See Figure 5 for the proper location.*

The QWVS42 and QWVS42-19 may be used when the installation is through an existing window opening.

A 2.5 inch spacer is to be placed on the window sill. This spacer must be weather resistant and attached to the window sill. See Figure 5 for the location of this spacer.

The QWVS42 and QWVS42-19 must extend through the window opening on the inside wall by four inches to allow clearance between the unit and the wall for the water pipes.

The window opening can be framed to provide an opening for the sleeve, 35 inches wide by 29.5 inches tall. The height of the opening is measured from the top surface of the 2.5 inch spacer. Once the opening is framed the sheeting can be installed. The sheeting material must not extend into the opening.

The sleeve should be test fit into the opening to make sure of the dimensions. The sleeve must be inserted into the opening from the outside of the building. The bottom of the sleeve must be level from side to side, and the sleeve must be square in the opening. A slope is built into the bottom of the sleeve from the inside to the outside. This will allow any water that gets into the sleeve to drain out. Once the test fit is completed, the sleeve must be removed from the opening and 1/4 inch bead of sealant must be applied to the mounting flanges of the sleeve. (See Figure 2.)

The sleeve is then reinserted into the prepared opening from the outside of the building. All of the mounting flanges must contact the exterior wall. Check to see that there is enough sealant to make this joint water tight. Additional sealant must be applied as necessary. The sleeve must be centered in the opening, and the bottom of the sleeve must be checked to make certain that it is level from side to side. The bottom flange should be secured to the wall by using two screws through the holes in the bottom mounting flange of the sleeve. The sleeve must be checked to make sure that it is square in the opening. Once the sleeve is square, the side and top mounting flanges of the sleeve must be secured to the wall with screws through the holes in the flanges. The gaps between the side flanges, and the top and bottom flanges must be filled with additional sealant.

There are two brackets supplied with the sleeve for attachment to the unit. Position these brackets to the sleeve and attach with three screws per side. Roll unit up to sleeve making sure the rear of the cabinet is tight against the gasket on the sleeve flange to provide an air tight seal. Drill 1/8 diameter holes through the brackets in to the cabinet side and attach with screws provided. See Figure 5 for more detail.