INSTALLATION INSTRUCTIONS

HEATED DRAIN TUBE

**MODEL:
QCDS48H**

**FOR USE WITH WALL SLEEVE FOR THE
QT_{EC} LINE OF PRODUCTS**



BARD MANUFACTURING COMPANY
Bryan, Ohio 43506

Since 1914...Moving, ahead just as planned.

Manual: 2100-394
Supersedes:
File: Volume II, Tab 14
Date: 09-14-01

Model QCDS48H is a heated condensate drain system to be used in conjunction with the wall sleeve for the QTEC line of products. The QCDS48H is required in those areas where outdoor temperature will be below freezing. There are two heaters in this assembly, one in the drain box and one attached to the drain tube. These heaters are self-regulating.

Supply voltage required is 115 volts. The total power draw is 20 watts.

Before the wall sleeve is attached to the wall make adequate clearance for the drain tube assembly. (See Figure 1.)

The following are the installation instructions for the Condensate Drain system model QCDS48H:

1. Four 3/16" holes must be drilled in the sleeve side for the drain mounting attachment screws. Refer to Figure 2.

2. A 1/2" hole must be drilled in the sleeve side for the overflow tube. Refer to Figure 2.
3. Place sleeve in wall and attach per instructions supplied with sleeve.
4. Attach drain box to sleeve. (See Figure 2.)
5. Seal overflow tube to sleeve. (See Figure 3.)
6. A fill plate is provided to enclose the area where the drain tube exits the exterior wall. It is to be attached with four field-supplied screws.
7. An elbow is provided to be attached to the open end of the drain tube. It can be soft soldered in place. Do not use high temperature brazing material.
8. Connect heater leads to a 115 volt circuit. See wiring diagram below.
9. Install the water trap in the rear QTEC drain connection. (See Figure 4.)

WIRING DIAGRAM FOR QCDS48H

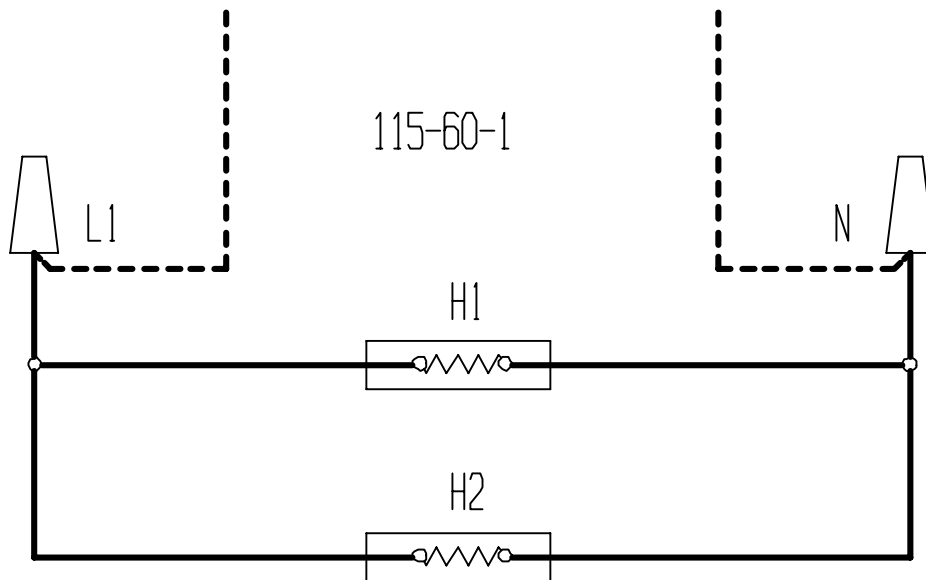

4100-802

**FIGURE 1
WALL SLEEVE DRAWINGS**

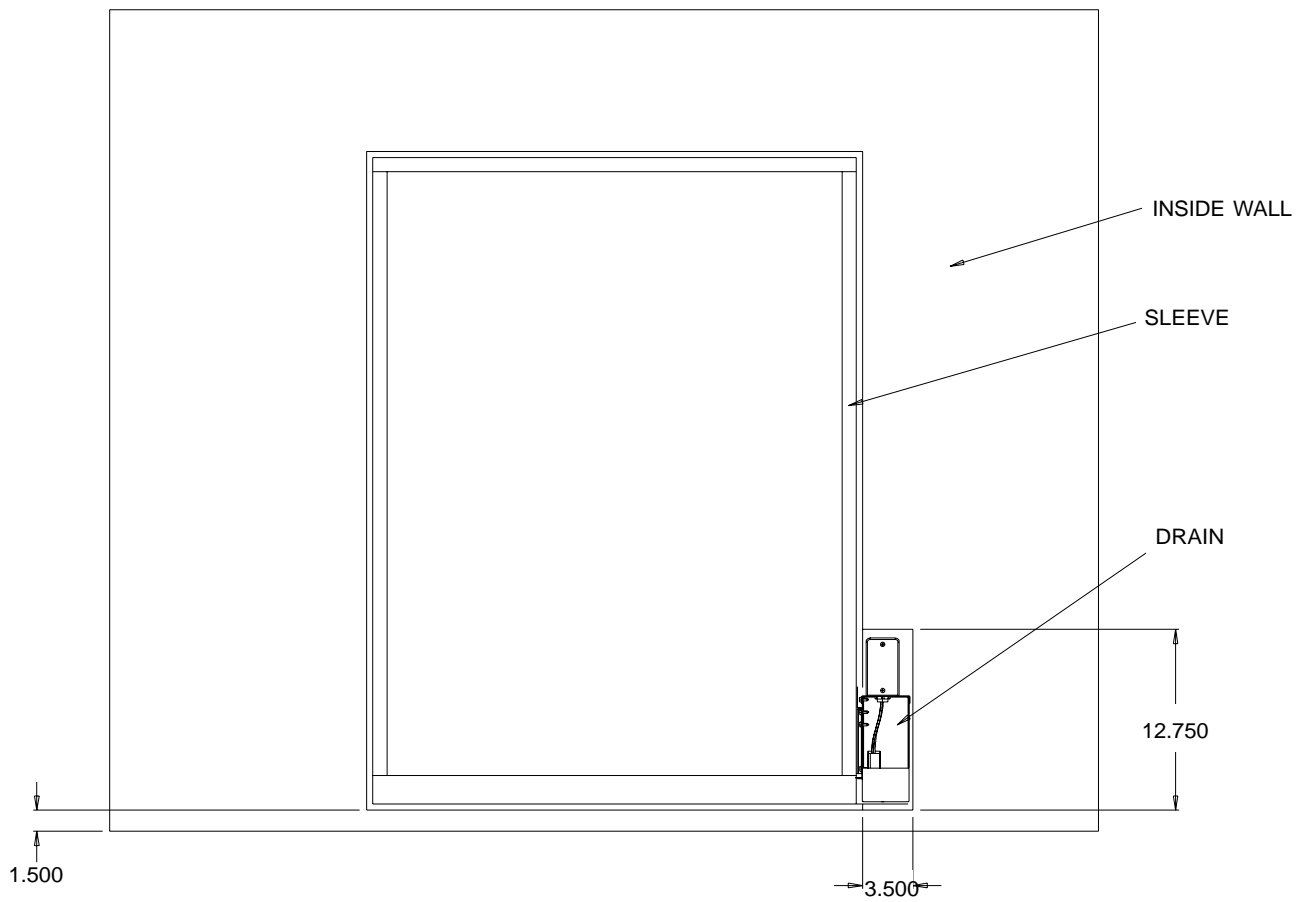
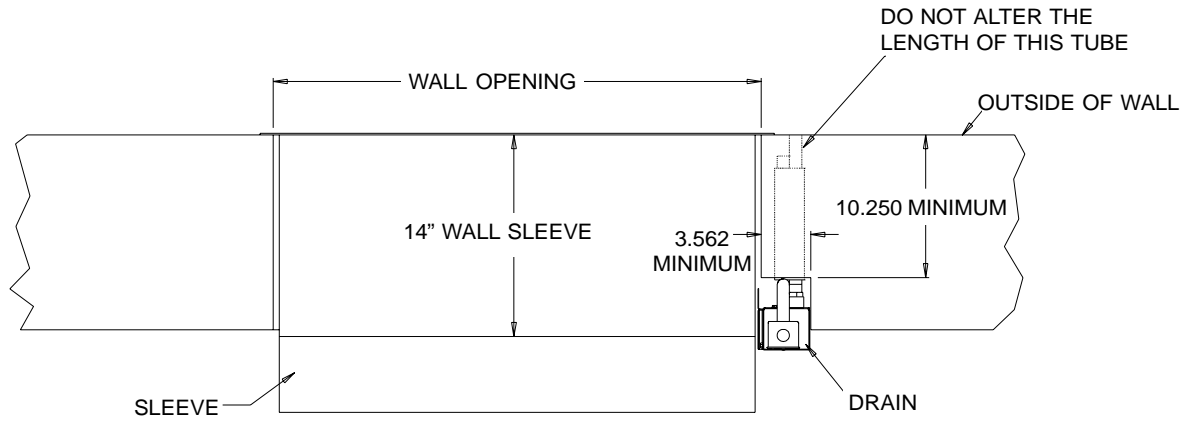

MIS-1669

FIGURE 2
CONDENSATE DRAIN INSTALLATION

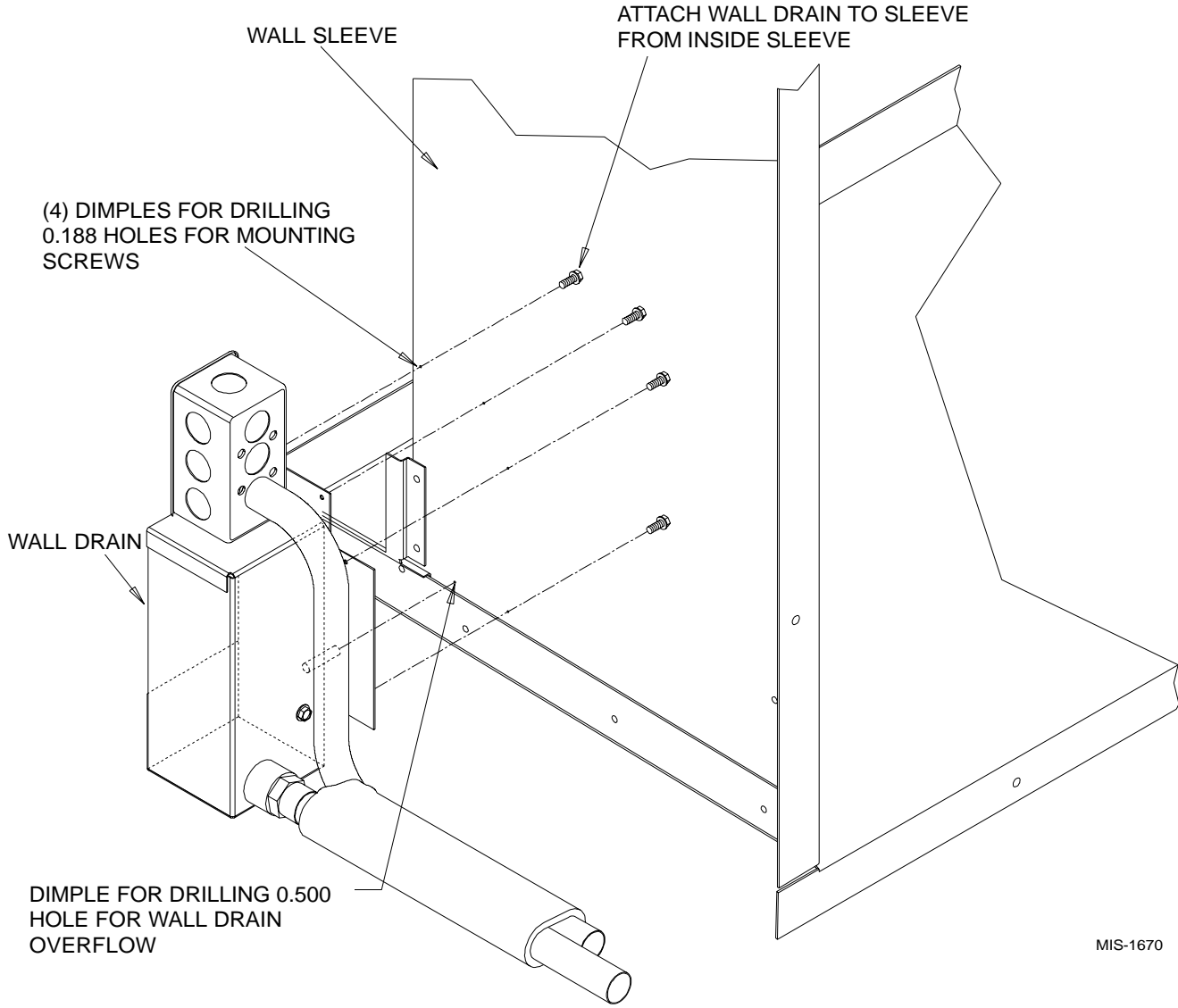
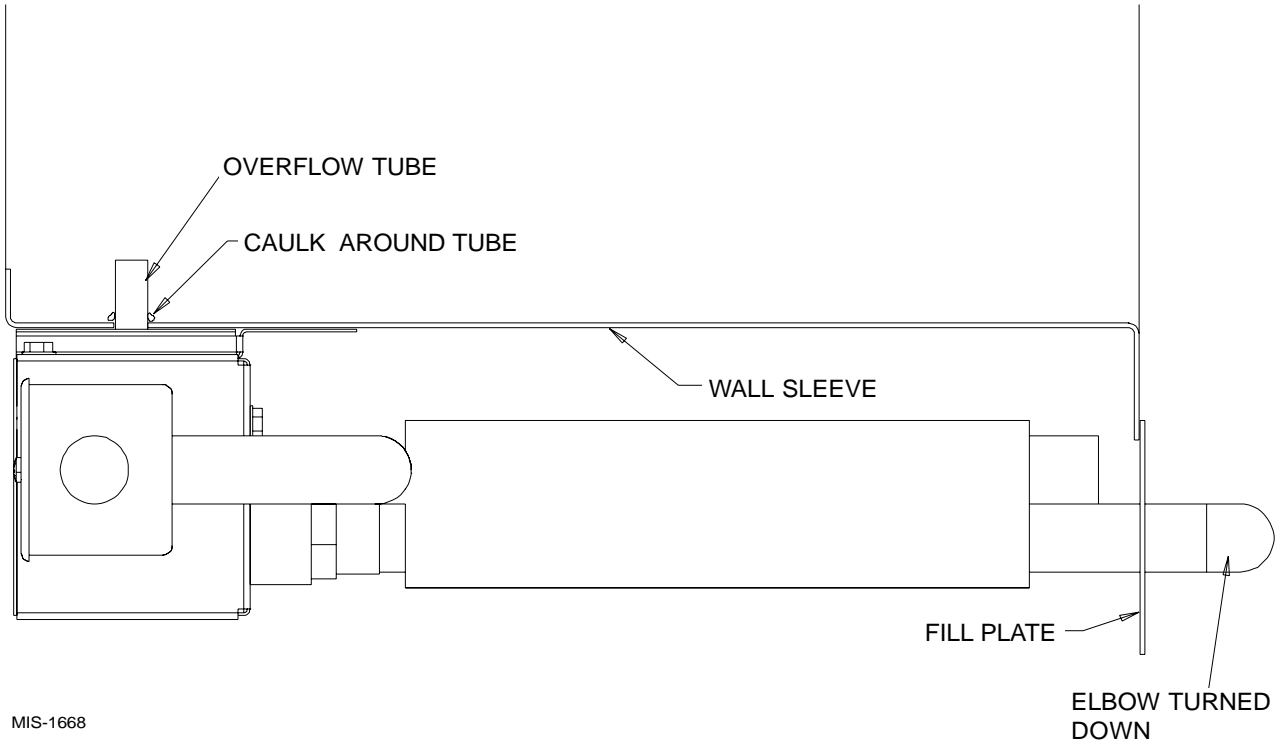

FIGURE 3
TOP SECTION VIEW
CONDENSATION DRAIN INSTALLATION



MIS-1668

FIGURE 4
CONDENSATE DRAIN INSTALLATION

