INSTALLATION INSTRUCTIONS

WGPM-1, WGPM-2

QW SERIES PUMP MODULE KIT

FOR USE WITH ALL QW SERIES
AIR TO WATER HEAT PUMPS



Climate Control Solutions

Bard Manufacturing Company, Inc.
Bryan, Ohio 43506
Since 1914...Moving, ahead just as planned.

Manual: 2100-395B
Supersedes: 2100-395A
File: Volume II, Tab 14
Date: 06-02-04

NOTE: Installation of this kit in QWxxx-C Models (460 volt electrical) requires the use of the WGRK-1 relay kit. This kit is not required for QWxxx-A or QWxxx-B models (240 volt electrical).

The WGHK-1 hose kit is recommended to connect this pump module to the water coil. The following instructions assume the use of this hose kit for installation:

1. Remove lower door to gain access to the compressor and water coil area.
2. Install male half of the ball valve unions into the heat pump connection side of the pump module. (See Figure 1.)
3. Secure the pump module to the back panel of the QW with the bolts and washers provided. (See Figure 1.)
4. Install male half of the unions into the water coil inlet and outlets. (See Figure 1.)
5. Install hoses between the unions.
6. If the unit is a 460 volt unit (QWxxx-C), install a WGRK-1 relay kit. See Installation Manual for WGRK-1 kit.
7. Connect the wires from the pump module to the terminal block or relay. (See Figure 2.)

FIGURE 1

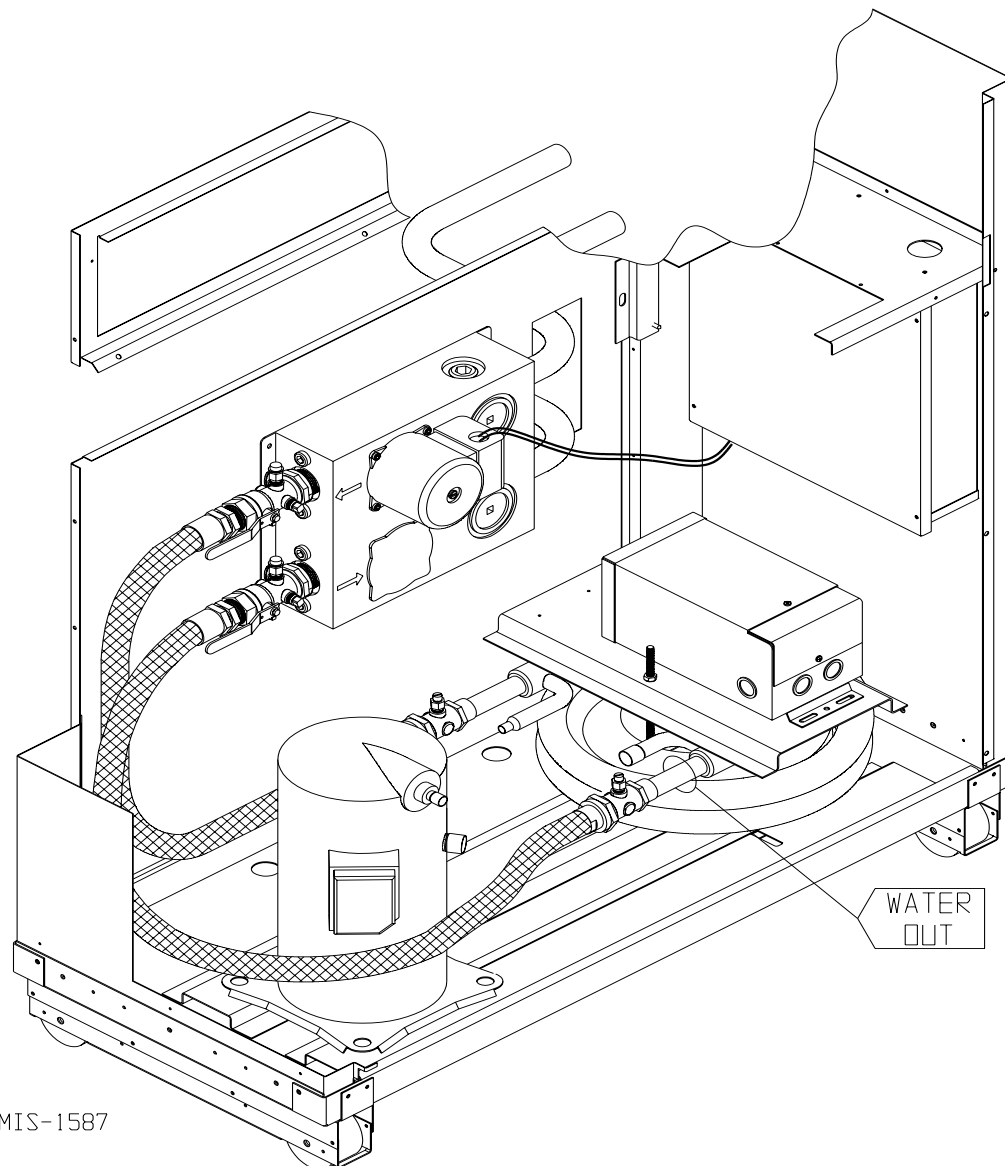
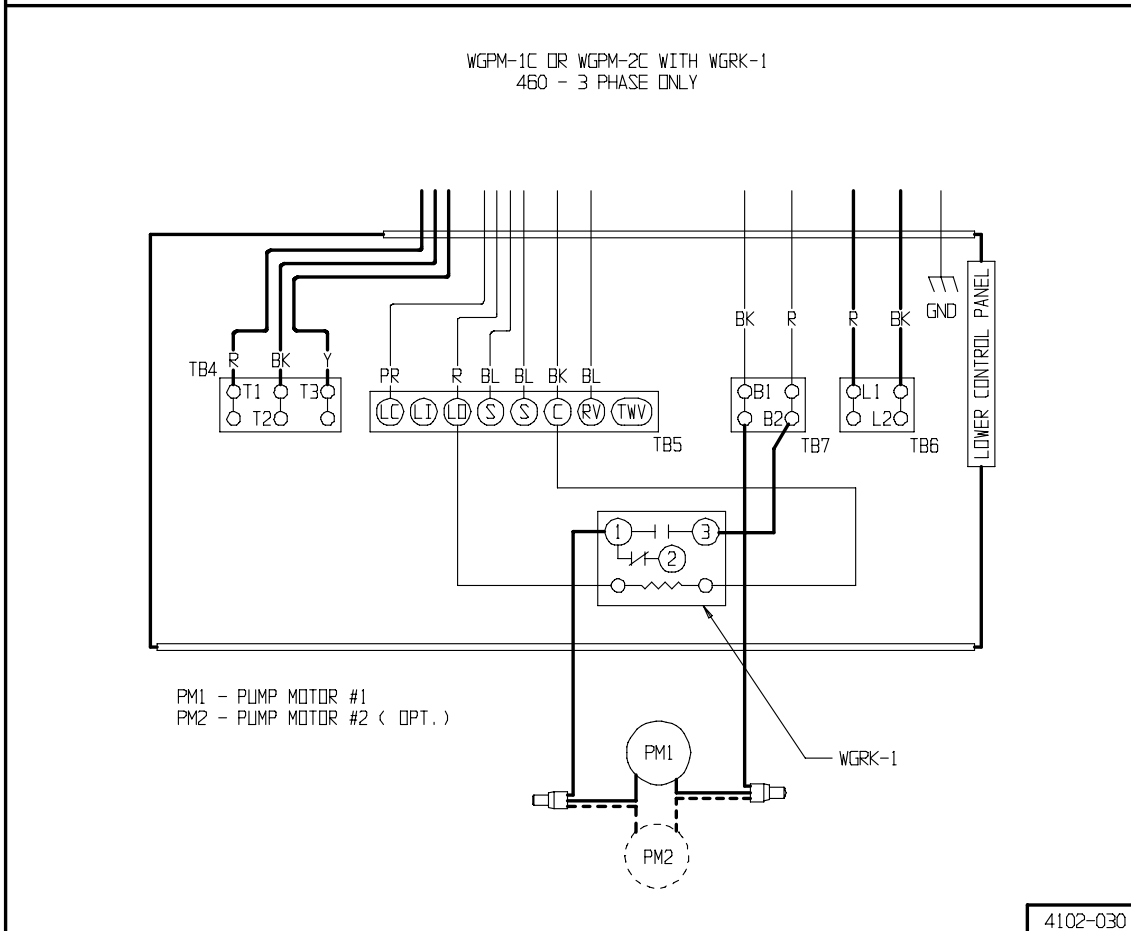
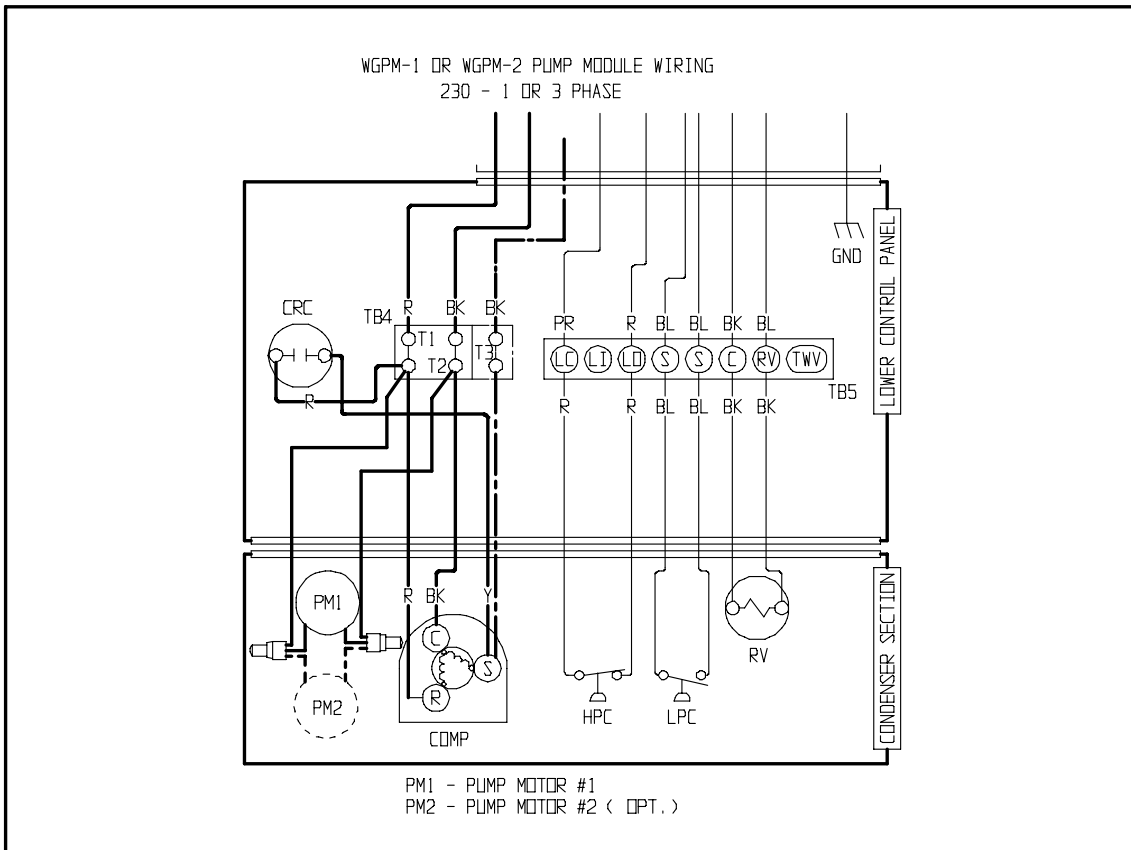

FIGURE 2



4102-030