

---

# INSTALLATION INSTRUCTIONS

---

## WALL MOUNTED PACKAGE HEAT PUMPS

**Models:**

**WH421**

**WH483**

**WH602**



BARD MANUFACTURING COMPANY, INC.  
Bryan, Ohio 43506

*Since 1914...Moving ahead, just as planned.*

Manual: 2100-399C  
Supersedes: 2100-399B  
File: Volume III Tab 17  
Date: 07-20-06

# CONTENTS

---

## Getting Other Information and Publications

For more information, contact these publishers: ..... 3

## Wall Mount General Information

Air Conditioner Wall Mount Model Nomenclature ....	4
Shipping Damage .....	7
General .....	7
Duct Work .....	7
Filters .....	7
Fresh Air Intake .....	8
Condensate Drain .....	8

## Installation Instructions

Wall Mounting Information .....	9
Mounting the Unit .....	9
Typical Installations .....	9
Wiring – Main Power .....	13
Wiring – Low Voltage Wiring .....	13
Optional Outdoor Thermostat Applications .....	14
Electric Heat Hold-Off .....	15
Thermostat Indicators .....	16

## Figures

Figure 1 Unit Dimensions .....	5
Figure 2 Blower Damper Assembly .....	8
Figure 3 Mounting Instructions .....	10
Figure 3A Electric Heat Clearance .....	10
Figure 4 Wall-Mounting Instructions .....	11
Figure 5 Wall-Mounting Instructions .....	11
Figure 6 Common Wall-Mounting Instructions ...	12
Figure 7 Unit 24V Terminal Board .....	13
Figure 8 Compressor Cutoff Thermostat Wiring .....	14
Figure 9 Compressor Cutoff Thermostat Wiring .....	14
Figure 10 Electric Heat Hold-Off Wiring .....	15
Figure 11 Electric Heat Hold-Off Wiring .....	15
Figure 12 Start-Up Label .....	17
Figure 13 Defrost Control Board .....	19
Figure 14 Fan Blade Setting .....	22

## Start Up

Important Installer Note .....	17
Crankcase Heaters .....	17
High Pressure Switch .....	17
Three Phase Scroll Compressor Start Up Information .....	17
Phase Monitor .....	18
Service Hints .....	18
Sequence of Operation .....	18
Pressure Service Ports .....	18
Defrost Cycle .....	18-19

## Troubleshooting

Solid State Heat Pump Control Troubleshooting Procedure .....	20
Checking Temperature Sensor Outdoor Unit Circuit .....	21
Fan Blade Setting Dimensions .....	22
Removal of Fan Shroud .....	22
Refrigerant Charge .....	22
Pressure Chart .....	23-24
Optional Accessories .....	24

## Tables

Table 1 Electric Heat Table .....	4
Table 2 Electrical Specifications .....	6
Table 3 Thermostat Wire Size .....	14
Table 4 Wall Thermostat .....	16
Table 5 Troubleshooting .....	20
Table 6 Fan Blade Dimensions .....	22
Table 7 Suction Line Temperatures .....	22
Table 8 Recommended Operating Ranges .....	22
Table 9 Indoor Blower Performance .....	22
Table 10 Maximum ESP of Operation .....	23
Table 11 Cooling Pressures .....	23
Table 12 Heating Pressures .....	24
Table 13 Optional Accessories .....	24

# Getting Other Information and Publications

---

These publications can help you install the air conditioner or heat pump. You can usually find these at your local library or purchase them directly from the publisher. Be sure to consult current edition of each standard.

National Electrical Code ..... ANSI/NFPA 70

Standard for the Installation ..... ANSI/NFPA 90A  
of Air Conditioning and Ventilating Systems

Standard for Warm Air ..... ANSI/NFPA 90B  
Heating and Air Conditioning Systems

Load Calculation for ..... ACCA Manual J or  
Residential Winter and Summer Air                      Manual N  
Conditioning

Low Pressure, Low Velocity ..... ACCA Manual D or  
Duct System Design for Winter                      Manual Q  
and Summer Air Conditioning

## FOR MORE INFORMATION, CONTACT THESE PUBLISHERS:

**ACCA    Air Conditioning Contractors of America**  
1712 New Hampshire Ave. N.W.  
Washington, DC 20009  
Telephone: (202) 483-9370  
Fax: (202) 234-4721

**ANSI    American National Standards Institute**  
11 West Street, 13th Floor  
New York, NY 10036  
Telephone: (212) 642-4900  
Fax: (212) 302-1286

**ASHRAE American Society of Heating Refrigerating  
and Air Conditioning Engineers, Inc.**  
1791 Tullie Circle, N.E.  
Atlanta, GA 30329-2305  
Telephone: (404) 636-8400  
Fax: (404) 321-5478

**NFPA    National Fire Protection Association**  
Batterymarch Park  
P.O. Box 9101  
Quincy, MA 02269-9901  
Telephone: (800) 344-3555  
Fax: (617) 984-7057

---

Manufactured under the following U.S. patent numbers:  
5,301,744; 5,002,116; 4,924,934; 4,875,520; 4,825,936  
Other patents pending.

# WALL MOUNT GENERAL INFORMATION

## HEAT PUMP WALL MOUNT MODEL NOMENCLATURE

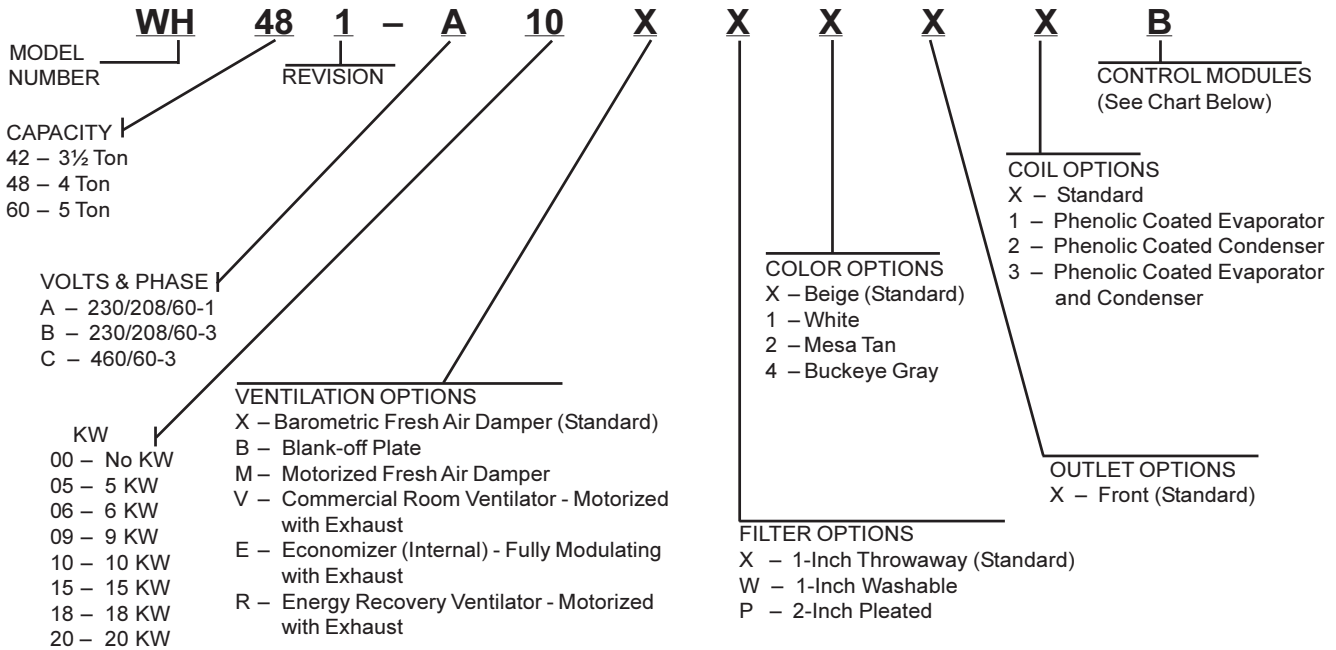

NOTE: For 0KW and circuit breakers (230/208 V) or pull disconnects (460 V) applications, insert 0Z in the KW field of model number.

**TABLE 1  
ELECTRIC HEAT TABLE**

Models	WH421-A				WH421-B WH483-B				WH421-C		WH483-A WH602-A				WH483-B WH602-B				WH483-C WH602-C	
	240-1		208-1		240-3		208-3		460-3		240-1		208-1		240-3		208-3		460-3	
	A	BTU	A	BTU	A	BTU	A	BTU	A	BTU	A	BTU	A	BTU	A	BTU	A	BTU	A	BTU
4											16.7	13650	14.4	10240						
5	20.8	17065	18.1	12800							20.8	17065	18.1	12800						
6					14.4	20500	12.5	15360	7.2	20480										
9					21.7	30600	18.7	23030	10.8	30700					21.7	30600	18.7	23030	10.8	30700
10	41.6	34130	36.2	25600							41.6	34130	36.2	25600						
15	62.5	51200	54.1	38400	36.2	51200	31.2	38400	18.0	51200	62.5	51200	54.1	38400	36.2	51200	31.2	38400	18.0	51200
18															43.3	61400	37.5	46050		
20											83.2	68250	72.1	51200						

**FIGURE 1  
UNIT DIMENSIONS**

SIZE SPECS FOR MIS-411

UNIT	WIDTH (W)	DEPTH (D)	HEIGHT (H)	SUPPLY			RETURN		E	F	G	I	J	K	L	M	N	O	P	Q
				A	B	C	B	Q												
42-48-60	42	22-1/4	84-7/8	9-7/8	29-7/8	15-7/8	29-7/8	29-7/8	43-7/8	19	31-5/8	30	32-11/16	27	34-3/4	32-1/2	3-1/4	43	23-7/8	10

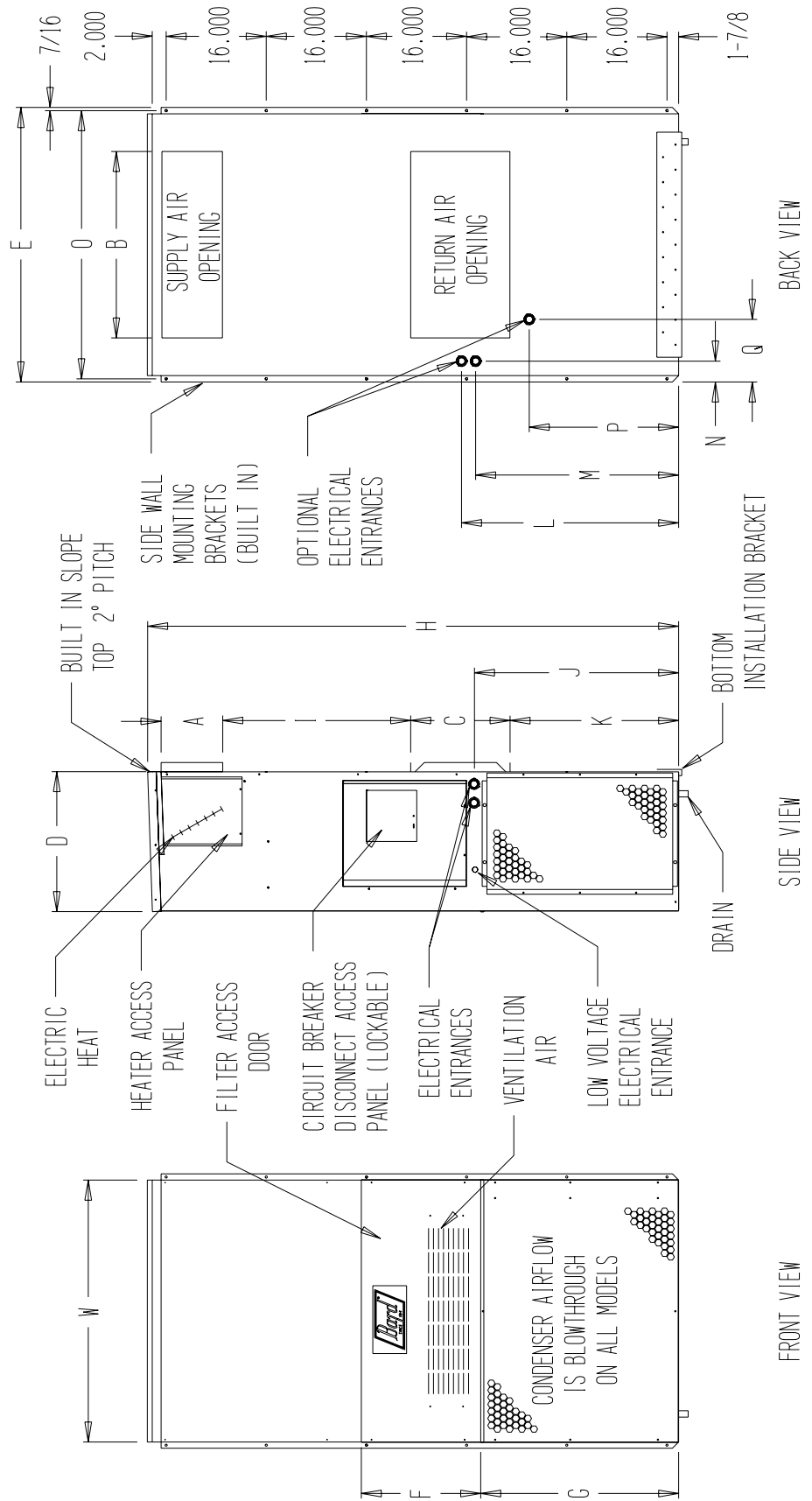

**TABLE 2  
ELECTRICAL SPECIFICATIONS**

Model	SINGLE CIRCUIT						DUAL CIRCUIT							
	Rated Volts & Phase	No. Field Power Ckts.	④	①	②	②	④		①		②		②	
			Minimum Circuit Ampacity	Maximum External Fuse or Circuit Breaker	Field Power Wire Size	Ground Wire Size	Minimum Circuit Ampacity	Maximum External Fuse or Ckt .Breaker	Field Power Wire Size		Ground Wire Size			
Ckt A	Ckt B	Ckt A	Ckt B	Ckt A	Ckt B	Ckt A	Ckt B	Ckt A	Ckt B	Ckt A	Ckt B	Ckt A	Ckt B	
WH421-A00, A0Z A05 ③ A10 A15	230/208-1	1	34	50	8	10	N/A	N/A	N/A	N/A	N/A	N/A	N/A	N/A
		1 or 2	60	70	6	8	34	26	50	30	8	10	10	10
		1 or 2	86	90	3	8	34	52	50	60	8	6	10	10
		1 or 2	86	90	3	8	34	52	50	60	8	6	10	10
WH421-B00, B0Z B06 ③ B09 B15	230/208-3	1	26	35	8	10	N/A	N/A	N/A	N/A	N/A	N/A	N/A	N/A
		1	44	50	8	10	N/A	N/A	N/A	N/A	N/A	N/A	N/A	N/A
		1	53	60	6	10	N/A	N/A	N/A	N/A	N/A	N/A	N/A	N/A
		1	53	60	6	10	N/A	N/A	N/A	N/A	N/A	N/A	N/A	N/A
WH421-C00, C0Z C06 ③ C09 C15	460-3	1	13	20	12	12	N/A	N/A	N/A	N/A	N/A	N/A	N/A	N/A
		1	23	25	10	10	N/A	N/A	N/A	N/A	N/A	N/A	N/A	N/A
		1	27	30	10	10	N/A	N/A	N/A	N/A	N/A	N/A	N/A	N/A
		1	27	30	10	10	N/A	N/A	N/A	N/A	N/A	N/A	N/A	N/A
WH483-A00, A0Z A04 ③ A05 A10 A15 A20	230/208-1	1	36	50	8	10	N/A	N/A	N/A	N/A	N/A	N/A	N/A	N/A
		1	57	60	6	8	N/A	N/A	N/A	N/A	N/A	N/A	N/A	N/A
		1 or 2	62	70	6	8	36	26	50	30	8	10	10	10
		1 or 1	88	100	3	8	36	52	50	60	8	6	10	10
		1 or 2	88	100	3	8	36	52	50	60	8	6	10	10
		1 or 2	110	110	2	6	59	52	60	60	6	6	10	10
WH483-B00, B0Z B06 ③ B09 B15 B18	230/208-3	1	25	35	8	10	N/A	N/A	N/A	N/A	N/A	N/A	N/A	N/A
		1	43	50	8	10	N/A	N/A	N/A	N/A	N/A	N/A	N/A	N/A
		1	52	60	6	10	N/A	N/A	N/A	N/A	N/A	N/A	N/A	N/A
		1	52	60	6	10	N/A	N/A	N/A	N/A	N/A	N/A	N/A	N/A
		1	60	60	6	10	N/A	N/A	N/A	N/A	N/A	N/A	N/A	N/A
WH483-C00, C0Z ③ C09 C15	460-3	1	13	15	14	14	N/A	N/A	N/A	N/A	N/A	N/A	N/A	N/A
		1	26	30	10	10	N/A	N/A	N/A	N/A	N/A	N/A	N/A	N/A
		1	27	30	8	10	N/A	N/A	N/A	N/A	N/A	N/A	N/A	N/A
WH602-A00, A0Z A05 ③ A10 A15 A20	230/208-1	1	45	60	8	10	N/A	N/A	N/A	N/A	N/A	N/A	N/A	N/A
		1 or 2	71	90	4	8	45	26	60	60	8	10	10	10
		1 or 1	97	110	3	6	45	52	60	60	8	6	10	10
		1 or 2	97	110	3	6	45	52	60	60	8	6	10	10
		1 or 2	110	110	2	6	59	52	60	60	6	6	10	10
WH602-B00, B0Z ③ B09 B15 B18	230/208-3	1	33	45	8	10	N/A	N/A	N/A	N/A	N/A	N/A	N/A	N/A
		1	60	60	6	10	N/A	N/A	N/A	N/A	N/A	N/A	N/A	N/A
		1	60	60	6	10	N/A	N/A	N/A	N/A	N/A	N/A	N/A	N/A
		1	60	60	6	10	N/A	N/A	N/A	N/A	N/A	N/A	N/A	N/A
WH602-C00, C0Z ③ C09 C15	460-3	1	16	20	12	12	N/A	N/A	N/A	N/A	N/A	N/A	N/A	N/A
		1	29	35	8	10	N/A	N/A	N/A	N/A	N/A	N/A	N/A	N/A
		1	29	35	8	10	N/A	N/A	N/A	N/A	N/A	N/A	N/A	N/A

① Maximum size of the time delay fuse or HACR type circuit breaker for protection of field wiring conductors.

② Based on 75°C copper wire. All wiring must conform to NEC and all local codes.

③ Maximum KW that can operate with heat pump on.

④ These "Minimum Circuit Ampacity" values are to be used for sizing the field power conductors. Refer to the National Electrical Code (latest version), article 310 for power conductor sizing.

**CAUTION:** When more than one field power conductor circuit is run through one conduit, the conductors must be derated. Pay special attention to note 8 of table 310 regarding Ampacity Adjustment Factors when more than 3 conductors are in a raceway.

## SHIPPING DAMAGE

Upon receipt of equipment, the carton should be checked for external signs of shipping damage. If damage is found, the receiving party must contact the last carrier immediately, preferably in writing, requesting inspection by the carrier's agent.

## GENERAL

The equipment covered in this manual is to be installed by trained, experienced service and installation technicians.

The refrigerant system is completely assembled and charged. All internal wiring is complete.

The unit is designed for use with or without duct work. Flanges are provided for attaching the supply and return ducts.

These instructions and any instructions packaged with any separate equipment required to make up the entire heat pump system should be carefully read before beginning the installation. Note particularly "Starting Procedure" and any tags and/or labels attached to the equipment.

While these instructions are intended as a general recommended guide, they do not supersede any national and/or local codes in any way. Authorities having jurisdiction should be consulted before the installation is made. See Page 3 for information on codes and standards.

Size of unit for a proposed installation should be based on heat loss calculation made according to methods of Air Conditioning Contractors of America (ACCA). The air duct should be installed in accordance with the Standards of the National Fire Protection Association for the Installation of Air Conditioning and Ventilating Systems of Other Than Residence Type, NFPA No. 90A, and Residence Type Warm Air Heating and Air Conditioning Systems, NFPA No. 90B. Where local regulations are at a variance with instructions, installer should adhere to local codes.

## DUCT WORK

Any heat pump is more critical of proper operating charge and an adequate duct system than a straight air conditioning unit. All duct work, supply and return, must be properly sized for the design airflow requirement of the equipment. Air Conditioning Contractors of America (ACCA) is an excellent guide to proper sizing. All duct work or portions thereof not in the conditioned space should be properly insulated in order to both conserve energy and prevent condensation or moisture damage.

Refer to Table 10 for maximum static pressure available for duct design.

Design the duct work according to methods given by the Air Conditioning Contractors of America (ACCA). When duct runs through unheated spaces, it should be insulated with a minimum of one inch of insulation. Use insulation with a vapor barrier on the outside of the insulation. Flexible joints should be used to connect the duct work to the equipment in order to keep the noise transmission to a minimum.

A ¼ inch clearance to combustible material for the first three feet (3') of duct attached to the outlet air frame is required. See Wall Mounting Instructions and Figures 3, 4 and 5 for further details.

Ducts through the walls must be insulated and all joints taped or sealed to prevent air or moisture entering the wall cavity.



## CAUTION

Some installations may not require any return air duct. A metallic return air grille is required with installations not requiring a return air duct. The spacing between louvers on the grille shall not be larger than 5/8 inches.

Any grille that meets the 5/8 inch louver criteria, may be used. It is recommended that Bard Return Air Grille Kit RG-2 through RG-5 or RFG-2 through RFG-5 be installed when no return duct is used. Contact distributor or factory for ordering information. If using a return air filter grille, filters must be of sufficient size to allow a maximum velocity of 400 fpm.

*NOTE: If no return air duct is used, applicable installation codes may limit this cabinet to installation only in a single story structure.*

## FILTERS

A 1-inch throwaway filter is supplied with each unit. The filter slides into position making it easy to service. This filter can be serviced from the outside by removing the service door. A 1-inch washable filter and 2-inch pleated filter are also available as optional accessories. The internal filter brackets are adjustable to accommodate the 2-inch filter by bending down the tabs to allow spacing for the 2-inch filters.

## FRESH AIR INTAKE

All units are built with fresh air inlet slots punched in the service panel.

If the unit is equipped with the fresh air damper assembly, the assembly is shipped already attached to the unit. The damper blade is locked in the closed position. To allow the damper to operate, the maximum and minimum blade position stops must be installed. See Figure 2.

All capacity, efficiency and cost of operation information as required for Department of Energy "Energyguide" Fact Sheets is based upon the fresh air blank-off plate in place and is recommended for maximum energy efficiency.

The blank-off plate is available upon request from the factory and is installed in place of the fresh air damper shipped with each unit.

## CONDENSATE DRAIN

A plastic drain hose extends from the drain pan at the top of the unit down to the unit base. There are openings in the unit base for the drain hose to pass through. In the event the drain hose is connected to a drain system of some type, it must be an open or vented type system to assure proper drainage.

**FIGURE 2  
BLOWER DAMPER ASSEMBLY**

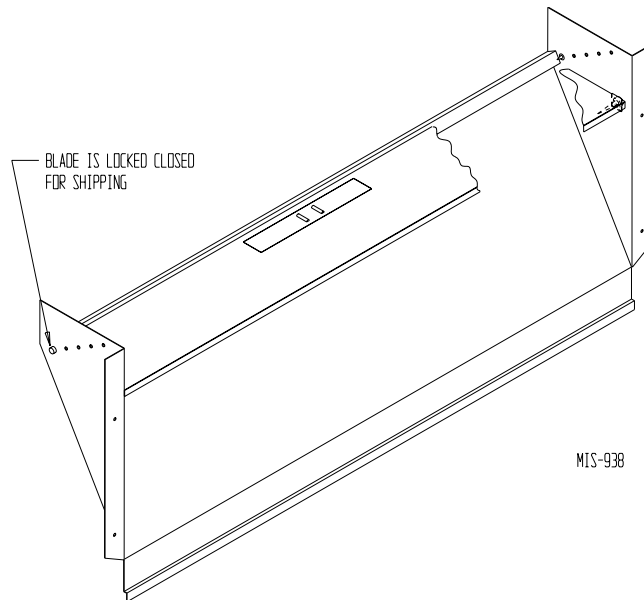



# INSTALLATION INSTRUCTIONS

## WALL MOUNTING INFORMATION

1. Two holes, for the supply and return air openings, must be cut through the wall as shown in Figure 3.
2. On wood-frame walls, the wall construction must be strong and rigid enough to carry the weight of the unit without transmitting any unit vibration. See Figures 4 and 5.

### **WARNING**

Fire hazard can result if ¼ inch clearance to combustible materials for supply air duct is not maintained. See Figure 3.

3. Concrete block walls must be thoroughly inspected to insure that they are capable of carrying the weight of the installing unit. See Figure 4.

## MOUNTING THE UNIT

1. These units are secured by wall mounting brackets, which secure the unit to the outside wall surface at both sides. A bottom mounting bracket is provided for ease of installation, but it is not required.
2. The unit itself is suitable for “0” inch clearance, but the supply air duct flange and the first 3 feet of supply air duct require a minimum of ¼ inch clearance to combustible material. If a combustible wall, use a minimum of 30½" x 10½" dimensions for sizing. However, it is generally recommended that a 1-inch clearance is used for ease of installation and maintaining the required clearance to combustible material. The supply air opening would then be 32" x 12". See Figures 3, 3A and 5 for details.



### **WARNING**

Failure to provide the ¼ inch clearance between the supply duct and a combustible surface for the first 3 feet of duct can result in fire.

3. Locate and mark lag bolt locations and bottom mounting bracket location. See Figure 4.
4. Mount bottom mounting bracket.
5. Hook top rain flashing under back bend of top. Top rain flashing is shipped secured to the right side of the back.
6. Position unit in opening and secure with 5/16 lag bolts; use 7/8 inch diameter flat washers on the lag bolts.
7. Secure rain flashing to wall and caulk across entire length of top. See Figure 3.
8. For additional mounting rigidity, the return air and supply air frames or collars can be drilled and screwed or welded to the structural wall itself (depending upon wall construction). Be sure to observe required clearance if combustible wall.
9. On side-by-side installations, maintain a minimum of 20 inches clearance on right side to allow access to heat strips and control panel, and to allow proper airflow to the outdoor coil. Additional clearance may be required to meet local or national codes.

## TYPICAL INSTALLATIONS

See Figure 6 for common ways to install the wall-mount unit.

**FIGURE 3  
MOUNTING INSTRUCTIONS**

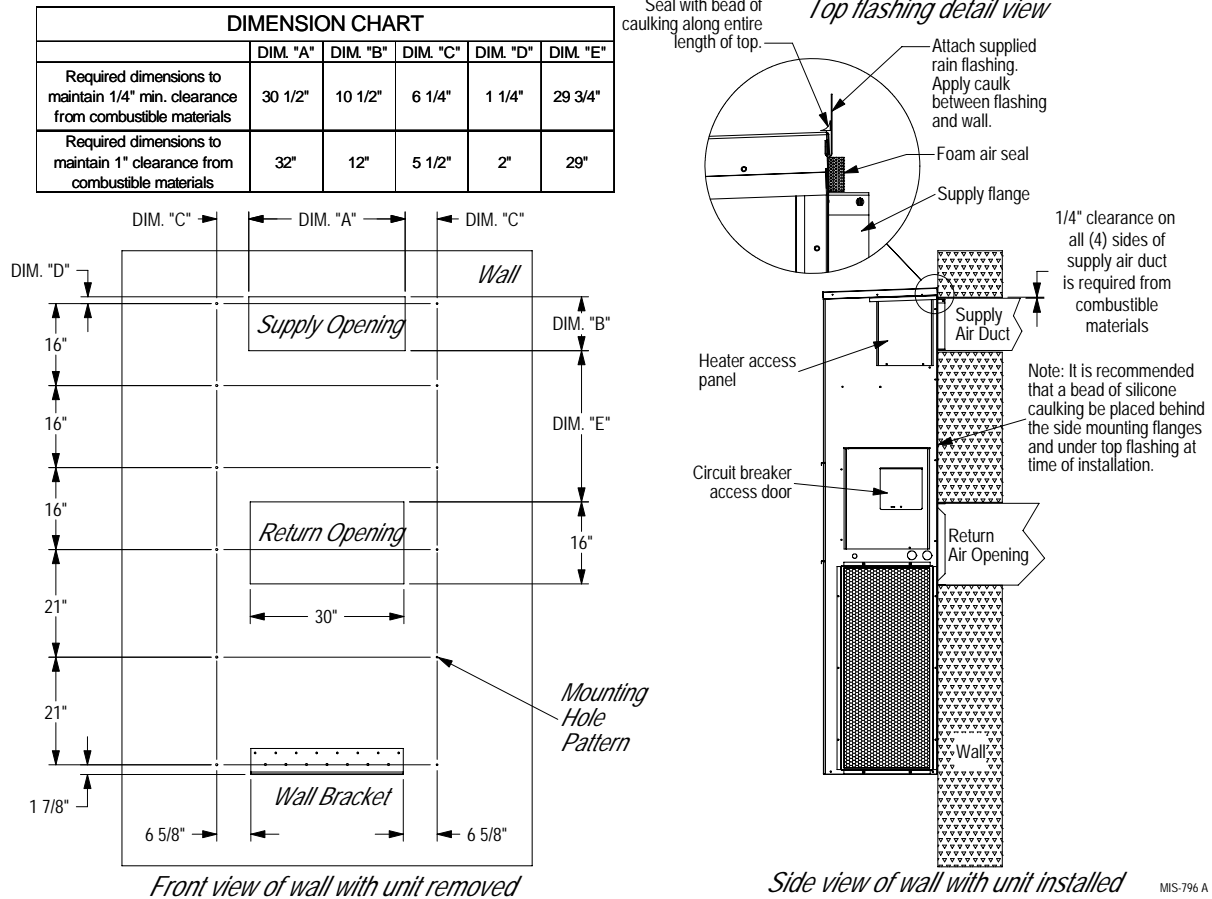

**FIGURE 3A  
ELECTRIC HEAT CLEARANCE**

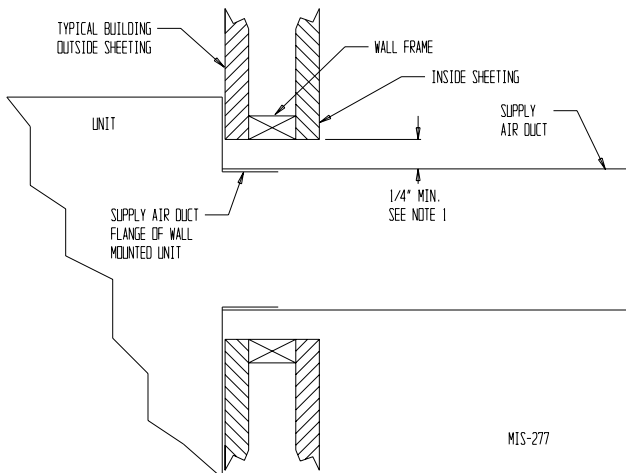

# WARNING

- A minimum of 1/4 inch clearance must be maintained between the supply air duct and combustible materials. This is required for the first 3 feet of ducting.
- It is important to insure that the 1/4 inch minimum spacing is maintained at all points.
- Failure to do this could result in overheating the combustible material and may result in fire.

## FIGURE 4 WALL-MOUNTING INSTRUCTIONS

SEE FIGURE 3 — MOUNTING INSTRUCTIONS

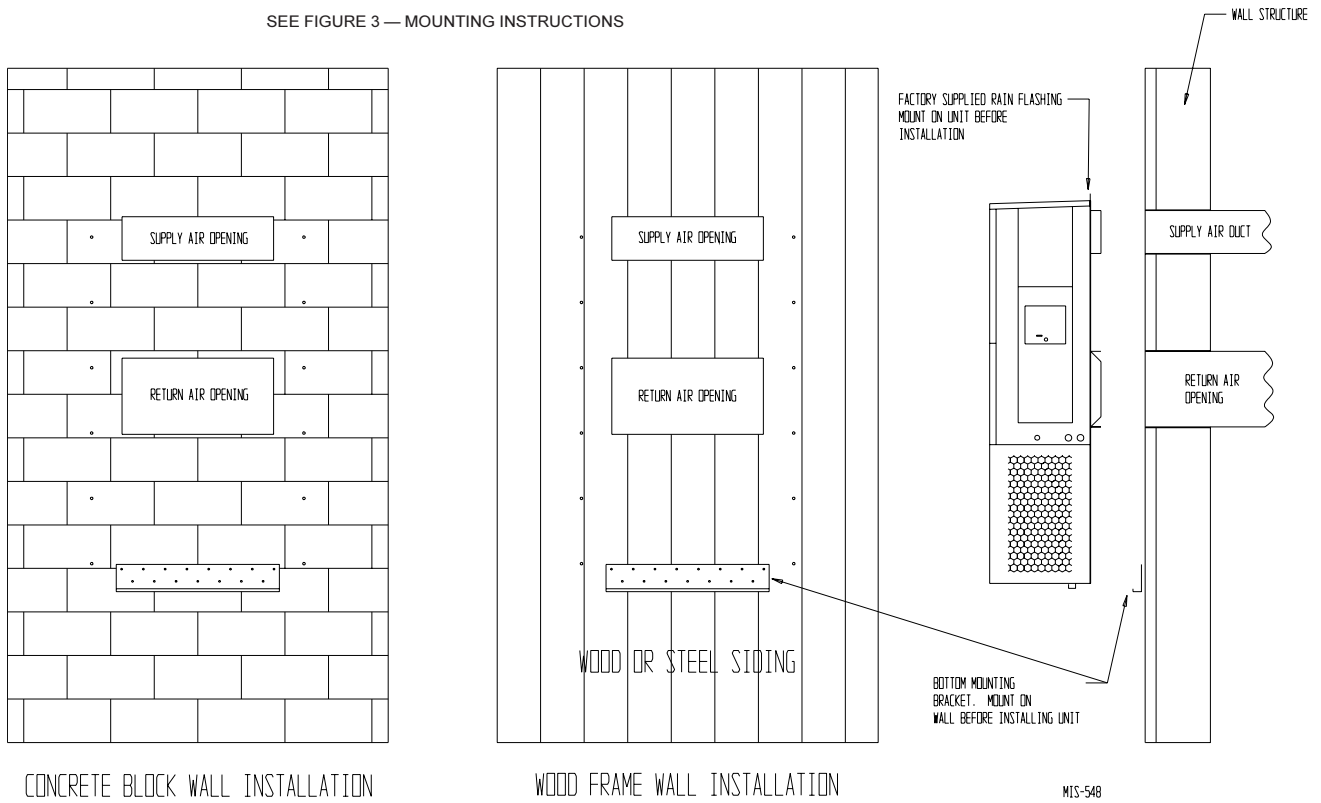

## FIGURE 5 WALL-MOUNTING INSTRUCTIONS

SEE UNIT DIMENSIONS, FIGURE 1,  
FOR ACTUAL DIMENSIONS

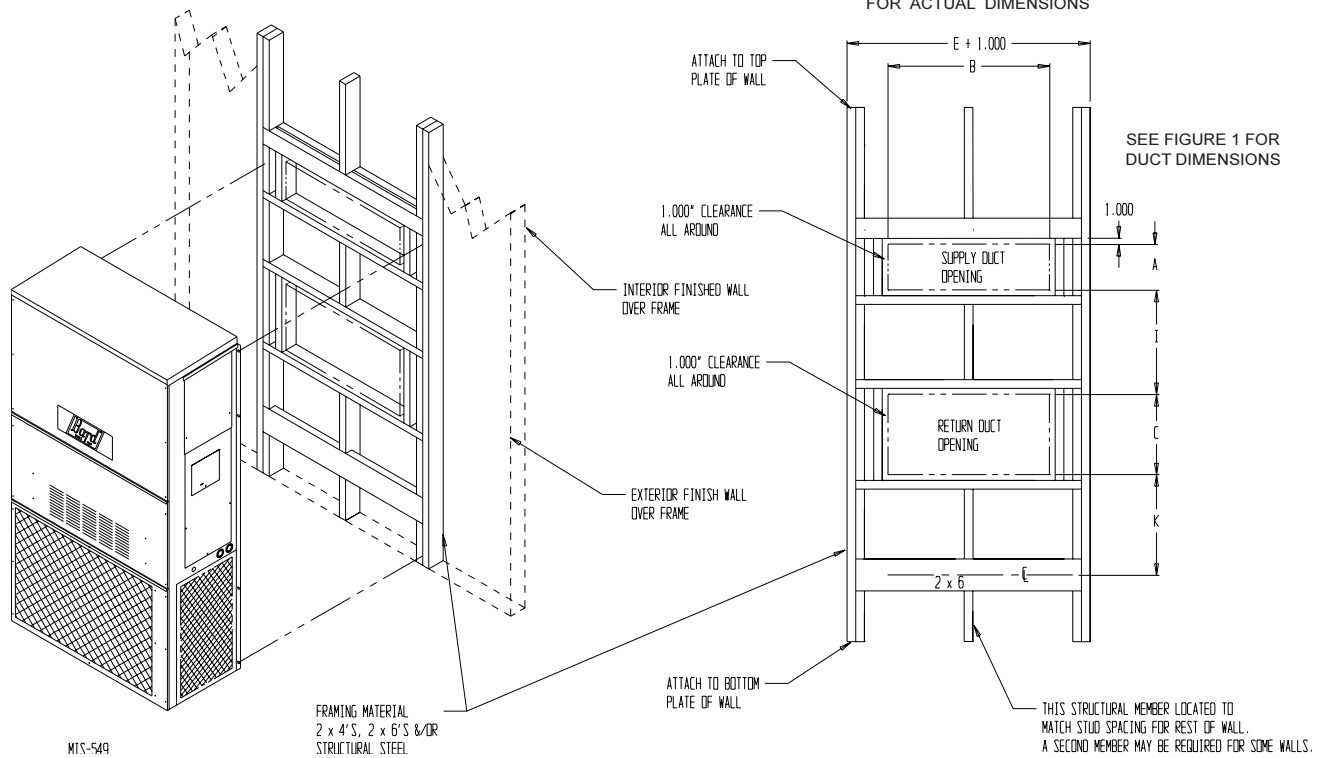

**FIGURE 6  
COMMON WALL-MOUNTING INSTALLATIONS**

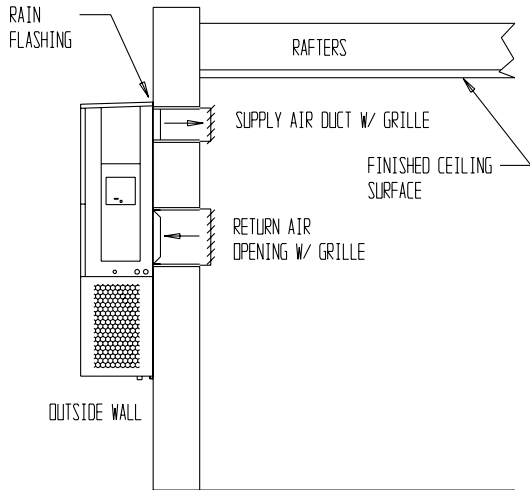

FREE AIR FLOW  
NO DUCT

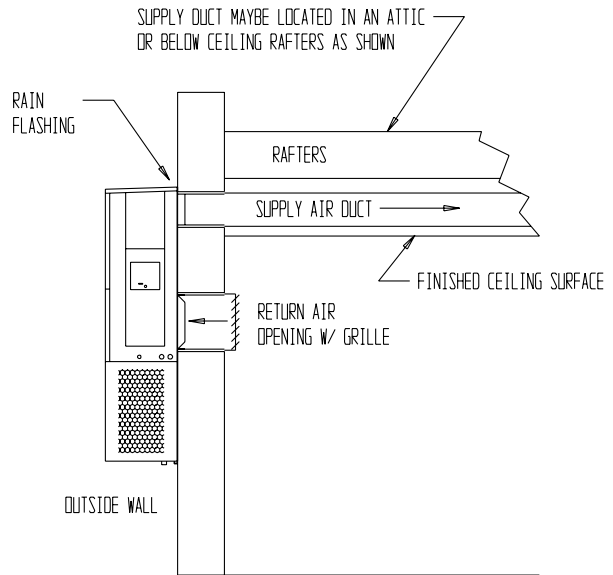

DUCTED SUPPLY  
RETURN AT UNIT

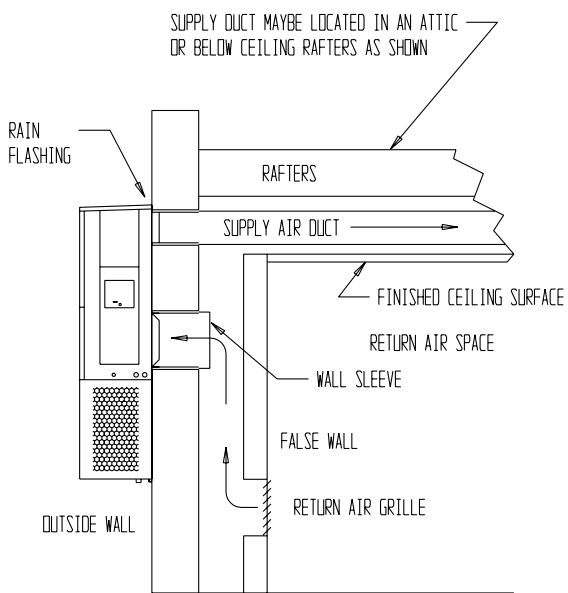

FALSE WALL INSTALLATION

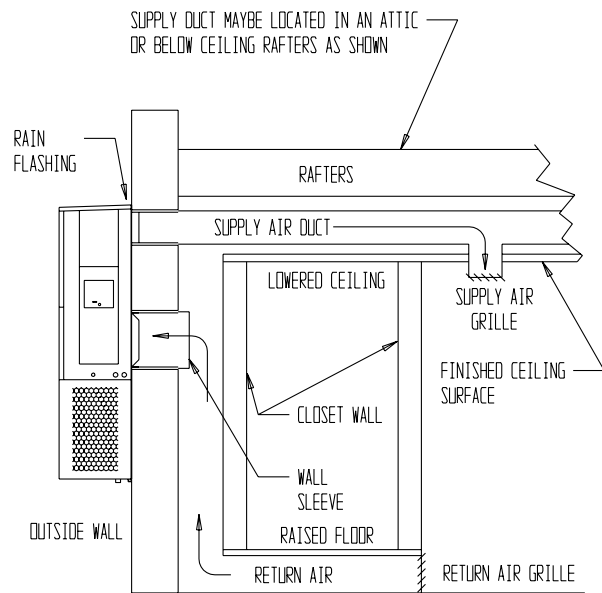

CLOSET INSTALLATION

## WIRING — MAIN POWER

Refer to the unit rating plate for wire sizing information and maximum fuse or “HACR” type circuit breaker size. Each outdoor unit is marked with a “Minimum Circuit Ampacity”. This means that the field wiring used must be sized to carry that amount of current. Depending on the installed KW of electric heat, there may be two field power circuits required. If this is the case, the unit serial plate will so indicate. All models are suitable only for connection with copper wire. Each unit and/or wiring diagram will be marked “Use Copper Conductors Only”. These instructions **must be** adhered to. Refer to the National Electrical Code (NEC) for complete current carrying capacity data on the various insulation grades of wiring material. All wiring must conform to NEC and all local codes.

The electrical data lists fuse and wire sizes (75°C copper) for all models, including the most commonly used heater sizes. Also shown are the number of field power circuits required for the various models with heaters.

The unit rating plate lists a “Maximum Time Delay Relay Fuse” or “HACR” type circuit breaker that is to be used with the equipment. The correct size must be used for proper circuit protection and also to assure that there will be no nuisance tripping due to the momentary high starting current of the compressor motor.

The disconnect access door on this unit may be locked to prevent unauthorized access to the disconnect. To convert for the locking capability, bend the tab located in the bottom left hand corner of the disconnect opening under the disconnect access panel straight out. This tab will now line up with the slot in the door. When shut, a padlock may be placed through the hole in the tab preventing entry.

See Start-up section for information on three phase scroll compressor start-ups.

## WIRING — LOW VOLTAGE WIRING

230/208V, 1 phase and 3 phase equipment dual primary voltage transformers. All equipment leaves the factory wired on 240V tap. For 208V operation, reconnect from 240V to 208V tap. The acceptable operating voltage range for the 240 and 208V taps are:

Tap	Range
240	253 - 216
208	220 - 187

*NOTE: The voltage should be measured at the field power connection point in the unit and while the unit is operating at full load (maximum amperage operating condition).*

Nine (9) wires should be run from thermostat subbase to the 24V terminal board in the unit. A nine conductor, 18 gauge copper, color-coded thermostat cable is recommended. The connection points are shown in Figure 7.

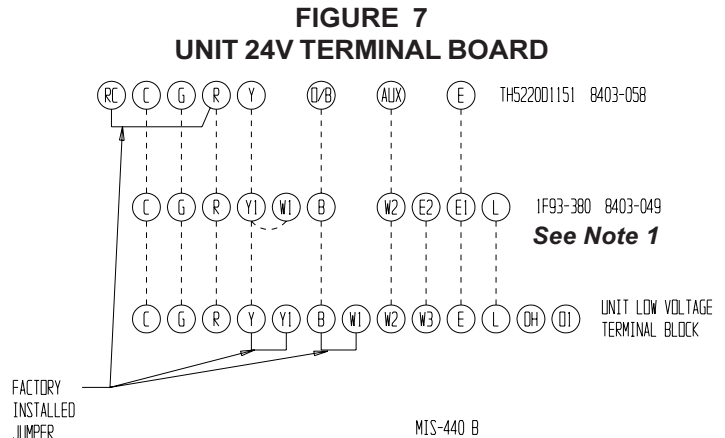

**Note 1:** 1F93-380 thermostat must be set to “Heat Pump” mode to operate properly.

Press the program “RUN” button to make sure the thermostat is in run program model.

Press time “FWD” and “BACK” at the same time to enter User Configuration Menu.

Press and hold set “TIME” and “DAY” for about 3 seconds to enter Installer Menu.

The thermostat will display “MULTI STG”

Press the “UP” or “DOWN” button until the display reads “HEAT PUMP”

Press program “RUN” button to resume operation.

**TABLE 3  
THERMOSTAT WIRE SIZE**

Transformer VA	FLA	Wire Gauge	Maximum Distance In Feet
55	2.3	20 gauge	45
		18 gauge	60
		16 gauge	100
		14 gauge	160
		12 gauge	250

**OPTIONAL OUTDOOR THERMOSTAT APPLICATIONS**

Since most equipment at the time of manufacture is not designated for any specific destination of the country and are installed in areas not approaching the lower outdoor temperature range, outdoor thermostats are not factory installed as standard equipment, but are offered as an option. There are also different applications for applying outdoor thermostats. The set point of either type of outdoor thermostat application is variable with

geographic region and sizing of the heating equipment to the individual structure. Utilization of the heating Application Data, and the heat loss calculation of the building are useful in determining the correct set points.

*NOTE: The additional LAB (low ambient bypass) relay is required to prevent heater operation during low temperature cooling operation.*

**OPTIONAL COMPRESSOR CUTOFF THERMOSTAT (See Figures 8 and 9)**

Heat pump compressor operation at outdoor temperatures below 0°F are neither desirable nor advantageous in term of efficiency. An outdoor thermostat can be applied to take the mechanical heating (compressor) off line, and send the (compressor) signal to energize electric heat in its place (to make electric heat first stage heating). This can also be applied to bank the quantity of available electric heat. For example: A heat pump operates with 10KW second stage heat – once the outdoor thermostat has switched then operates 15KW without the compressor as first stage heat.

**FIGURE 8  
COMPRESSOR CUTOFF THERMOSTAT WIRING  
4 - 10KW 1PH --- 6 & 9KW 3-PH**

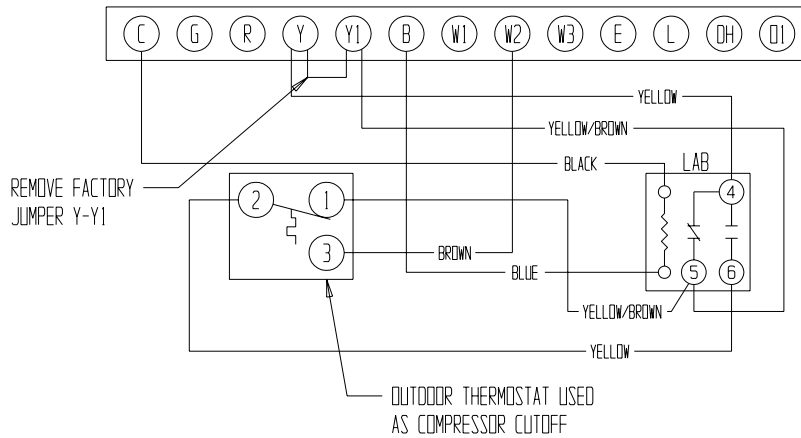

**FIGURE 9  
COMPRESSOR CUTOFF THERMOSTAT WIRING  
15 - 20KW 1-PH & 3-PH**

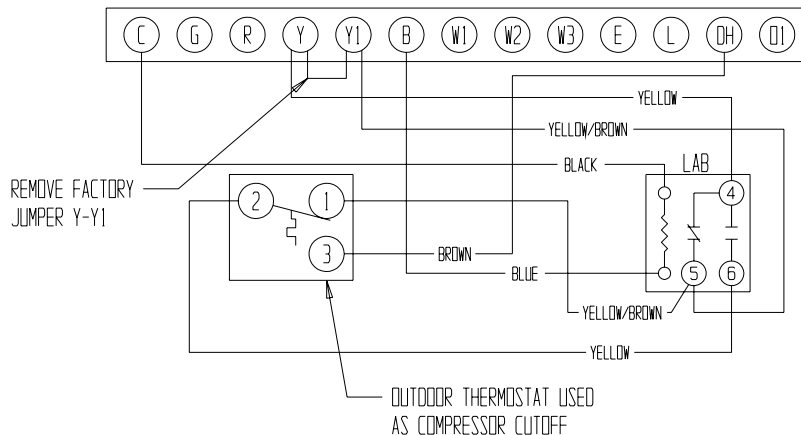

**ELECTRIC HEAT HOLD-OFF  
(SEE FIGURES 10 AND 11)**

In other applications, it is desirable to disable the operation of the electric heat until outdoor temperatures have reached a certain design point. This won't allow the electric heat to come on as second stage heating unless the outdoor temperature is below the set point of the outdoor thermostat. This is done to maximize

efficiency by utilizing the heat pump to bring the conditioned space temperature up, rather than cycling on the electric heat due a second stage call for heat from the thermostat on start-up coming off a night set-back condition or someone increasing the thermostat set point. (NOTE: Some programmable thermostats do have a built-in time delay for pulling in second stage heat when coming off set-back conditions.)

**FIGURE 10  
ELECTRIC HEAT HOLD-OFF WIRING  
4 – 10KW 1 PH — 6 & 9KW 3 PH**

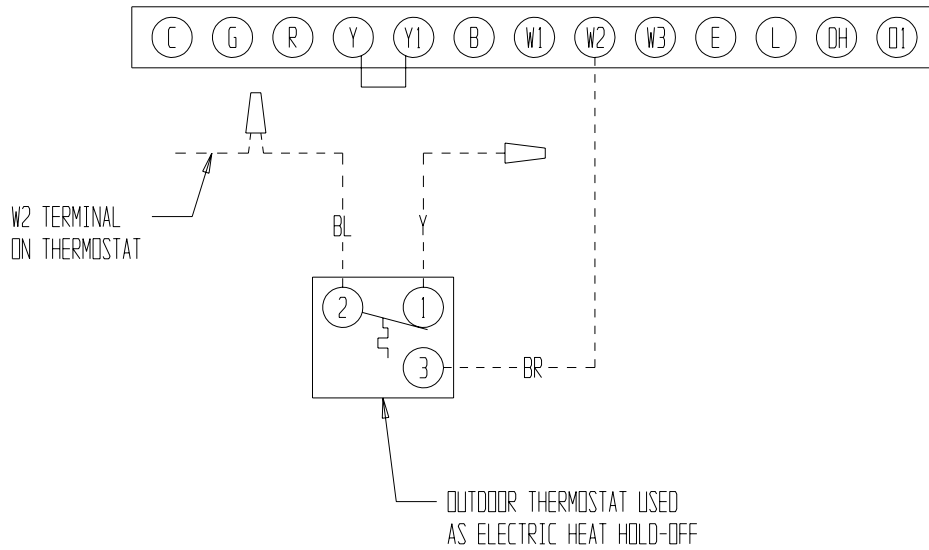

**FIGURE 11  
ELECTRIC HEAT HOLD-OFF WIRING  
15 – 20KW 1 PH & 3 PH**

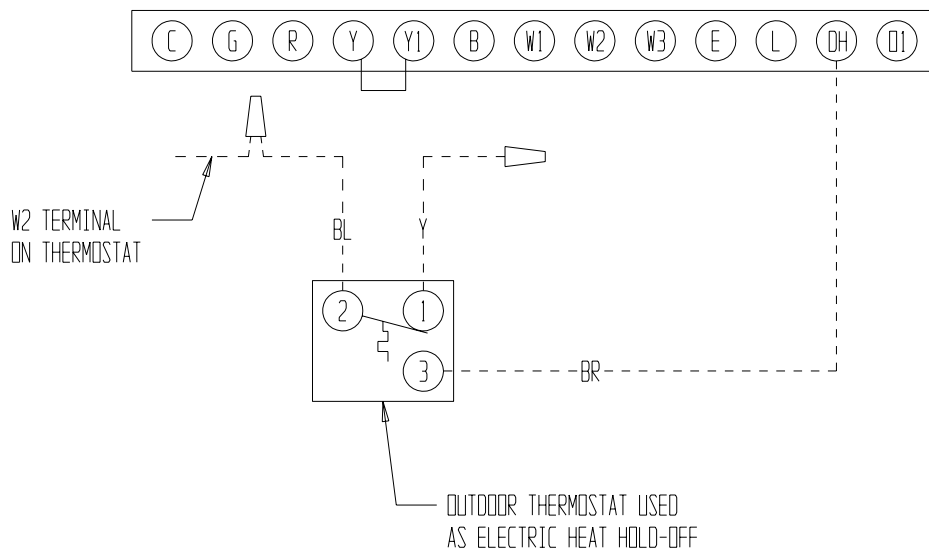

**TABLE 4  
WALL THERMOSTAT**

Thermostat	Predominant Features
8403-049 (1F93-380)	2 stage cool; 3 stage heat Programmable Electronic Auto or Manual changeover
8403-058 (TH5220D1151)	2 stage cool; 2 stage heat Electronic Non-Programmable Auto or Manual changeover

### **THERMOSTAT INDICATORS**

8403-049 (1F93-380) Thermostat:

In heating and cooling, the LED will illuminate green for first stage and yellow for second stage. The same LED will illuminate red for Emergency heating mode and will flash red if there is a malfunction in the system. The Malfunction indicator is accomplished by a relay output from the heat pump control board. A condition such as loss of charge or high head pressure will cause the flashing red light to activate. This is a signal to the operator of the equipment to place system in the emergency position.

8403-058 (TH5220D1151) Thermostat:

Thermostat will display on the screen “Em Heat” when the thermostat is set on emergency heat.



## IMPORTANT INSTALLER NOTE

For improved start-up performance, wash the indoor coil with a dishwashing detergent.

## CRANKCASE HEATERS

WH421 units are provided with compressor crankcase heat. WH602 and WH483 units are not provided with crankcase heat. These units utilize scroll compressors which do not require crankcase heat in this application.

The WH421 models have an insertion well-type heater located in the lower section of the compressor housing this is a self-regulating type heater that draws only enough power to maintain the compressor at a safe temperature on these units.

Some form of crankcase heat is essential to prevent liquid refrigerant from migrating to the compressor, causing oil pump out on compressor start-up and possible valve failure due to compressing a liquid.

The decal in Figure 12 is affixed to all WH421 units detailing start-up procedure. This is very important. *Please read carefully.*

## HIGH PRESSURE SWITCH

The WH483 and WH602 models are supplied with a remote reset high pressure switch. If tripped, this pressure switch may be reset by turning the thermostat off then back on again.

## THREE PHASE SCROLL COMPRESSOR START UP INFORMATION

Scroll compressors, like several other types of compressors, will only compress in one rotational direction. Direction of rotation is not an issue with single phase compressors since they will always start and run in the proper direction.

However, three phase compressors will rotate in either direction depending upon phasing of the power. Since there is a 50-50 chance of connecting power in such a way as to cause rotation in the reverse direction, verification of proper rotation must be made. All three phase units incorporate a phase monitor to ensure proper field wiring. See the Phase Monitor later in this manual.

Verification of *proper rotation* must be made any time a compressor is change or rewired. If improper rotation is corrected at this time there will be no negative impact on the durability of the compressor. However, reverse operation for over one hour may have a negative impact on the bearing due to oil pump out.

FIGURE 12  
START UP LABEL

**IMPORTANT**

**THESE PROCEDURES MUST BE FOLLOWED AT INITIAL START UP AND AT ANY TIME POWER HAS BEEN REMOVED FOR 12 HOURS OR LONGER.**

**TO PREVENT COMPRESSOR DAMAGE WHICH MAY RESULT FROM THE PRESENCE OF LIQUID REFRIGERANT IN THE COMPRESSOR CRANKCASE:**

1. MAKE CERTAIN THE ROOM THERMOSTAT IS IN THE "OFF" POSITION. (THE COMPRESSOR IS NOT TO OPERATE.)
2. APPLY POWER BY CLOSING THE SYSTEM DISCONNECT SWITCH. THIS ENERGIZES THE COMPRESSOR HEATER WHICH EVAPORATES THE LIQUID REFRIGERANT IN THE CRANKCASE.
3. ALLOW 4 HOURS OR 60 MINUTES PER POUND OF REFRIGERANT IN THE SYSTEM AS NOTED ON THE UNIT RATING PLATE, WHICHEVER IS GREATER.
4. AFTER PROPER ELAPSED TIME THE THERMOSTAT MAY BE SET TO OPERATE THE COMPRESSOR.
5. EXCEPT AS REQUIRED FOR SAFETY WHILE SERVICING, DO NOT OPEN SYSTEM DISCONNECT SWITCH.

7961-411

*NOTE: If compressor is allowed to run in reverse rotation for several minutes, the compressor's internal protector will trip.*

All three phase ZR3 compressors are wired identical internally. As a result, once the correct phasing is determined for a specific system or installation, connecting properly phased power leads to the same Fusite terminal should maintain proper rotation direction.

Verification of proper rotation direction is made by observing that suction pressure drops and discharge pressure rises when the compressor is energized. Reverse rotation also results in an elevated sound level over that with correct rotations, as well as, substantially reduced current draw compared to tabulated values.

The direction of rotation of the compressor may be changed by reversing any two line connections to the unit.

## PHASE MONITOR

All units with three phase compressors are equipped with a 3 phase line monitor to prevent compressor damage due to phase reversal.

The phase monitor in this unit is equipped with two LEDs. If the Y signal is present at the phase monitor and phases are correct, the green LED will light. If phases are reversed, the red fault LED will be lit and compressor operation is inhibited.

If a fault condition occurs, reverse two of the supply leads to the unit. Do not reverse any of the unit factory wires as damage may occur.

## SERVICE HINTS

1. Caution homeowner to maintain clean air filters at all times. Also, not to needlessly close off supply and return air registers. This reduces airflow through the system, which shortens equipment service life as well as increasing operating costs
2. Switching to heating cycle at 75° F or higher outside temperature may cause a nuisance trip of the remote reset high pressure switch. Turn thermostat off, then on to reset the high pressure switch.
3. The heat pump wall thermostats perform multiple functions. Be sure that all function switches are correctly set for the desired operating mode before trying to diagnose any reported service problems.
4. Check all power fuses or circuit breakers to be sure they are the correct rating.
5. Periodic cleaning of the outdoor coil to permit full and unrestricted airflow circulation is essential.

## SEQUENCE OF OPERATION

**COOLING** – Circuit R-Y makes at thermostat pulling in compressor contactor, starting the compressor and outdoor motor. The G (indoor motor) circuit is automatically completed on any call for cooling operation or can be energized by manual fan switch on subbase for constant air circulation.

**HEATING** – A 24V solenoid coil on reversing valve controls heating cycle operation. Two thermostat options, one allowing “Auto” changeover from cycle to cycle and the other constantly energizing solenoid coil during heating season, and thus eliminating pressure equalization noise except during defrost, are to be used. On “Auto” option a circuit is completed from R-W1 and R-Y on each heating “on” cycle, energizing reversing valve solenoid and pulling in compressor contactor starting compressor and outdoor motor. R-G also make starting indoor blower motor. Heat pump heating cycle now in operation. The second option has no “Auto”

changeover position, but instead energizes the reversing valve solenoid constantly whenever the system switch on subbase is placed in “Heat” position, the “B” terminal being constantly energized from R. A Thermostat demand for heat completes R-Y circuit, pulling in compressor contactor starting compressor and outdoor motor. R-G also make starting indoor blower motor.

## PRESSURE SERVICE PORTS

High and low pressure service ports are installed on all units so that the system operating pressures can be observed. Pressure tables can be found later in the manual covering all models on both cooling and heating cycles. It is imperative to match the correct pressure curve to the unit by model number.

## DEFROST CYCLE

The defrost cycle is controlled by temperature and time on the solid state heat pump control. See Figure 13.

When the outdoor temperature is in the lower 40° F temperature range or colder, the outdoor coil temperature is 32° F or below. This coil temperature is sensed by the coil temperature sensor mounted near the bottom of the outdoor coil. Once coil temperature reaches 30° F or below, the coil temperature sensor sends a signal to the control logic of the heat pump control and the defrost timer will start.

After 60 minutes at 30° F or below, the heat pump control will place the system in the defrost mode.

During the defrost mode, the refrigerant cycle switches back to the cooling cycle, the outdoor motor stops, electric heaters are energized, and hot gas passing through the outdoor coil melts any accumulated frost. When the temperature rises to approximately 57° F, the coil temperature sensor will send a signal to the heat pump control which will return the system to heating operations automatically.

If some abnormal or temporary condition such as a high wind causes the heat pump to have a prolonged defrost cycle, the heat pump control will restore the system to heating operation automatically after 10 minutes.

The heat pump defrost control board has an option of 30, 60 or 90-minute setting. All models are shipped from the factory on the 60-minute pin. If special circumstances require a change to another time, remove the wire from the 60-minute terminal and reconnect to the desired terminal. The manufacturer's recommendation is for 60-minute defrost cycles. Refer to Figure 13.

There is a cycle speed up jumper on the control. This can be used to reduce the time between defrost cycle operation without waiting for time to elapse.

Use a small screwdriver or other metallic object, or another ¼ inch QC, to short between the *SPEEDUP* terminals to accelerate the HPC timer and initiate defrost.

Be careful not to touch any other terminals with the instrument used to short the *SPEEDUP* terminals. It may take up to 10 seconds with the *SPEEDUP* terminals shorted for the speedup to be completed and the defrost cycle to start.

***As soon as the defrost cycle kicks in remove the shorting instrument from the SPEEDUP terminals.***

Otherwise the timing will remain accelerated and run through the 1-minute minimum defrost length sequence in a matter of seconds and will automatically terminate the defrost sequence.

There is an initiate defrost jumper (sen jump) on the control that can be used at any outdoor ambient during the heating cycle to simulate a 0° coil temperature.

This can be used to check defrost operation of the unit without waiting for the outdoor ambient to fall into the defrost region.

By placing a jumper across the *SEN JMP* terminals (a ¼ inch QC terminal works best) the defrost sensor mounted on the outdoor coil is shunted out and will activate the timing circuit. This permits the defrost cycle to be checked out in warmer weather conditions without the outdoor temperature having to fall into the defrost region.

In order to terminate the defrost test the *SEN JMP* jumper must be removed. If left in place too long, the compressor could stop due to the high pressure control opening because of high pressure condition created by operating in the cooling mode with outdoor fan off. Pressure will rise fairly fast as there is likely no actual frost on the outdoor coil in this artificial test condition.

There is also a 5-minute compressor time delay function built into the HPC. This is to protect the compressor from short cycling conditions. In some instances, it is helpful to the service technician to override or speed up this timing period, and shorting out the *SPEEDUP* terminals for a few seconds can do this.

**FIGURE 13  
DEFROST CONTROL BOARD**

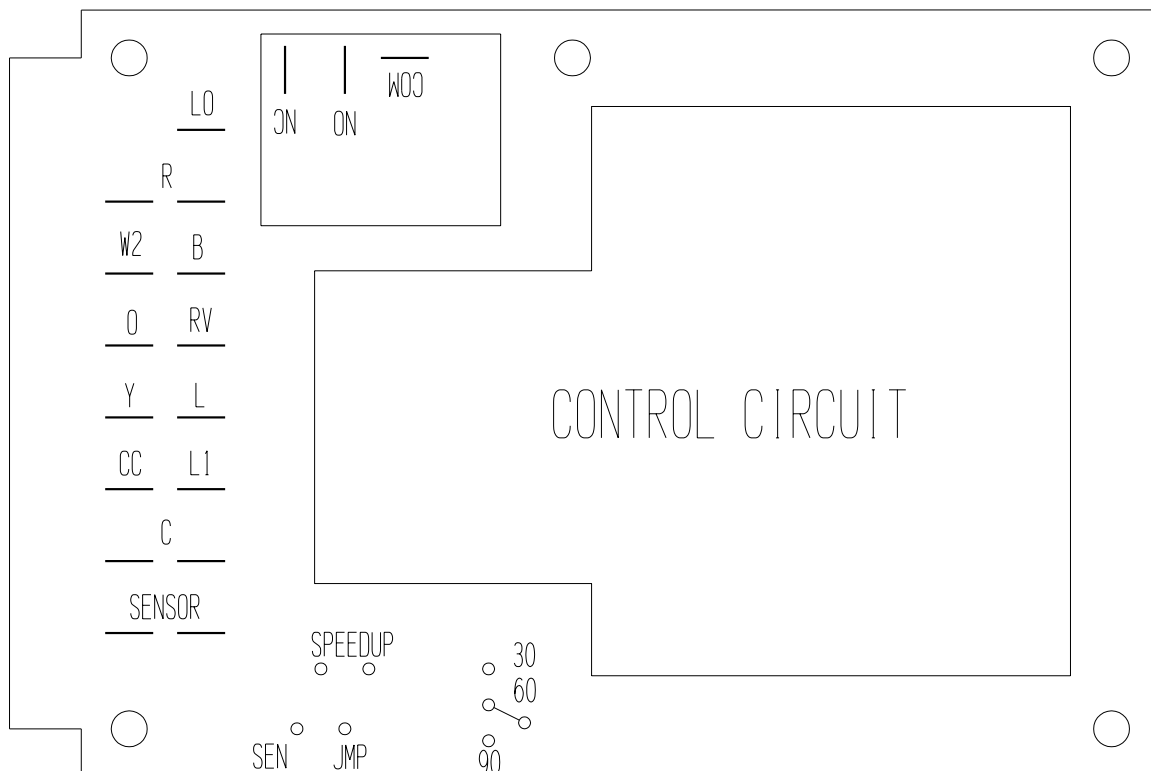

MIS-1174

# TROUBLESHOOTING

## SOLID STATE HEAT PUMP CONTROL TROUBLESHOOTING PROCEDURE

1. Turn on AC power supply to indoor and outdoor units.
2. Turn thermostat blower switch to fan “on” – the indoor blower should start. (If it doesn't, troubleshoot indoor unit and correct problem).
3. Turn thermostat blower switch to auto position. Indoor blower should stop.

4. Set system to heat or cool. Adjust thermostat to call for heat or cool – the indoor blower, compressor, and outdoor fan should start.

*NOTE: If there was no power to 24 volt transformer, the compressor and outdoor fan motor will not start for 5 minutes. This is because of the compressor short cycle protection.*

**TABLE 5  
TROUBLESHOOTING**

Symptom	Possible Causes	What to Check	How to Check or Repair
Compressor contactor does not energize (heating or cooling)	Control circuit wiring	Check for R connectio at unit and 24 volt between R - C	Run R connection to outdoor unit to power heat pump control.
	Compressor lock out	1. Check for 24V between L1-C on heat pump control 2. Check across high presure switch.	1. If no voltage between L1-C, turn thermostat off and on again to reset high pressure switch. 2. If high pressure switch is open and will not reset, replace high pressure switch.
	Compressor short cycle protection	Check for 24 V between CC-C and Y-C on heat pump control.	If not voltage between CC-C, jumper speed up terminal, and within 10 seconds power should appear between CC-C. Remove speed up jumper after 10 seconds.
	Heat pump control defective	Check all other possible causes. Manual 2100-065	Replace heat pump control.
	Contactor defective	Check for open or shorted coil winding.	Replace contactor.
	Power phasing not correct	Check for red LED on phase monitor (3 phase units only).	Switch two power leads to the unit.
Fan outdoor motor does not run (cooling or heating except during defrost)	Motor defective	Check for open or shorted motor winding.	Replace motor.
	Motor capacitor defective	Check capacitor ratng. Check for open or shorted capacitor.	Replace capacitor.
	Heat pump control defective	Check across fan relay on heat pump control (Com-NC).	Replace heat pump control.
Reversing valve does not energize (heating only)	Reversing valve solenoid coil defective	Check for open or shorted coil.	Replace solenoid Coil.
	Heat pump control defective	Check for 24V between RV-C and B-C.	1. Check control circuit wiring. 2. Replace heat pump control.
Unit will not go into defrost (heating only)	Temperature sensor or heat pump control defective	Disconnect temperature sensor from board and jumper across speed up terminals and sen jump terminals. This should caruse the unit to go through a defrost cycle within one minute.	1. If unit goes through defrost cycle, replace temperature sensor. 2. If unit does not go through defrost cycle, replace heat pump control.
Unit will not come out of defrost (heating only)	Temperature sensor or heat pump control defective	Jumper across speed up terminals. This should cause the unit to come out of defrost within one minute.	1. If unit comes out of defrost cycle replace temperature sensor. 2. If unit does not come out of defrost cycle, replace heat pump control.

## CHECKING TEMPERATURE SENSOR OUTSIDE UNIT CIRCUIT

1. Disconnect temperature sensor from board and from outdoor coil.
2. Use an ohmmeter and measure the resistance of the sensor. Also use ohmmeter to check for short or open.
3. Check resistance reading to chart of resistance. Use sensor ambient temperature. (Tolerance of part is  $\pm 10\%$ .)
4. If sensor resistance reads very low, then sensor is shorted and will not allow proper operation of the heat pump control.
5. If sensor is out of tolerance, shorted, open or reads very low ohms then it should be replaced.

**TEMPERATURE F VS. RESISTANCE R OF TEMPERATURE SENSOR**

F	R	F	R	F	R	F	R
-25.0	196871	13.0	56985	53.0	19374	89.0	7507
-24.0	190099	14.0	55284	52.0	18867	90.0	7334
-23.0	183585	15.0	53640	53.0	18375	91.0	7165
-22.0	177318	16.0	52051	54.0	17989	92.0	7000
-21.0	171289	17.0	50514	55.0	17434	93.0	6840
-20.0	165487	18.0	49028	56.0	16984	94.0	6683
-19.0	159904	19.0	47590	57.0	16547	95.0	6531
-18.0	154529	20.0	46200	58.0	16122	96.0	6383
-17.0	149355	21.0	44855	59.0	15710	97.0	6239
-16.0	144374	22.0	43554	60.0	15310	98.0	6098
-15.0	139576	23.0	42295	61.0	14921	99.0	5961
-14.0	134956	24.0	41077	62.0	14544	100.0	5827
-13.0	130506	25.0	39898	63.0	14177	101.0	5697
-12.0	126219	26.0	38757	64.0	13820	102.0	5570
-11.0	122089	27.0	37652	65.0	13474	103.0	5446
-10.0	118108	28.0	36583	66.0	13137	104.0	5326
-9.0	114272	29.0	35548	67.0	12810	105.0	5208
-8.0	110575	30.0	34545	68.0	12492	106.0	5094
-7.0	107010	31.0	33574	69.0	12183	107.0	4982
-6.0	103574	32.0	32634	70.0	11883	108.0	4873
-5.0	100260	33.0	31723	71.0	11591	109.0	4767
-4.0	97064	34.0	30840	72.0	11307	110.0	4663
-3.0	93981	35.0	29986	73.0	11031	111.0	4562
-2.0	91008	36.0	29157	74.0	10762	112.0	4464
-1.0	88139	37.0	28355	75.0	10501	113.0	4367
0.0	85371	38.0	27577	76.0	10247	114.0	4274
1.0	82699	39.0	26823	77.0	10000	115.0	4182
2.0	80121	40.0	26092	78.0	9760	116.0	4093
3.0	77632	41.0	25383	79.0	9526	117.0	4006
4.0	75230	42.0	24696	80.0	9299	118.0	3921
5.0	72910	43.0	24030	81.0	9077	119.0	3838
6.0	70670	44.0	23384	82.0	8862	120.0	3757
7.0	68507	45.0	22758	83.0	8653	121.0	3678
8.0	66418	46.0	22150	84.0	8449	122.0	3601
9.0	64399	47.0	21561	85.0	8250	123.0	3526
10.0	62449	48.0	20989	86.0	8057	124.0	3452
11.0	60565	49.0	20435	87.0	7869		
12.0	58745	50.0	19896	88.0	7686		

## FAN BLADE SETTING DIMENSIONS

Shown in the drawing in Figure 14 are the correct fan blade setting dimensions for proper air delivery across the outdoor coil.

Any service work requiring removal or adjustment in the fan and/or motor area will require that the dimensions below be checked and blade adjusted in or out on the motor shaft accordingly.

**FIGURE 14  
FAN BLADE SETTING**

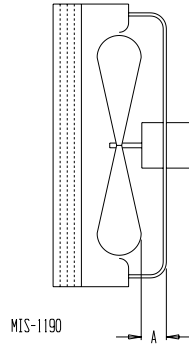

**TABLE 6  
FAN BLADE DIMENSIONS**

Model	Dimension A
WH421 WH483 WH602	1.75

## REMOVAL OF FAN SHROUD

1. Disconnect all power to unit.
2. Remove the screws holding both grilles – one on each side of unit – and remove grilles.
3. Remove screws holding fan shroud to condenser and bottom – (9) screws.
4. Unwire condenser fan motor.
5. Slide complete motor, fan blade, and shroud assembly out the left side of the unit.
6. Service motor/fan as needed.
7. Reverse steps to reinstall.

## REFRIGERANT CHARGE

The correct system R-22 charge is shown on the unit rating plate. Optimum unit performance will occur with a refrigerant charge resulting in a suction line temperature (6 inches from compressor) as shown in the Table 7.

**TABLE 7  
SUCTION LINE TEMPERATURES**

Model	Rated Airflow	95°F O.D. Temperature	82°F O.D. Temperature
WH421	1400	52 -- 54	62 -- 64
WH483	1550	53 -- 55	62 -- 64
WH602	1700	52 -- 54	61 -- 63

The suction line temperatures in Table 7 are based upon 80°F dry bulb/67 degrees F wet bulb (50 percent R.H.) temperature and rated airflow across the evaporator during cooling cycle.

**TABLE 8  
RECOMMENDED OPERATING RANGES**

Model	Rated CFM *	Rated ESP *	Recommended Air Flow Range
WH421	1400	.30	1600 -- 1150
WH483	1550	.20	1750 -- 1285
WH602	1700	.30	1950 -- 1375

\* Rated CFM and ESP on high speed tap.

**TABLE 9  
INDOOR BLOWER PERFORMANCE  
CFM @ 230V**

E.S.P. In H <sub>2</sub> O	WH421, WH483				WH602			
	Low 230V		High 230V		Low 230V		High 230V	
	Dry Coil	Wet Coil	Dry Coil	Wet Coil	Dry Coil	Wet Coil	Dry Coil	Wet Coil
.0	1650	1600	1885	1800	1600	1450	2200	2000
.1	1550	1500	1770	1665	1525	1375	2100	1900
.2	1450	1400	1635	1540			2000	1800
.3	1350	1300	1500	1400			1875	1700
.4	1300	1175	1370	1285			1775	1600
.5	-----	-----	1250	1150			1650	1475

**TABLE 10  
MAXIMUM ESP OF OPERATION  
ELECTRIC HEAT ONLY**

Model Speed KW	WH421		WH483		WH602	
	High Speed	Low Speed	High Speed	Low Speed	High Speed	Low Speed
-A00	.50	.50	.50	.50	.50	.40
-A04	----	----	.50	.50	----	----
-A05	.50	.50	.50	.50	.50	.25
-A10	.50	.45	.50	.45	.50	.25
-A15	.50	.45	.50	.45	.50	.25
-A20	----	----	.50	.45	.50	.25
-B00	.50	.50	.50	.50	.50	.40
-B09	.50	.45	.50	.45	.50	.30
-B15	.50	.45	.50	.45	.50	.30
-B18	----	----	.50	.45	.50	.30
-C00	.50	.50	.50	.50	.50	.40
-C09	.50	.40	.50	.40	.50	.35
-C15	.50	.40	.50	.40	.50	.35

Values shown are for units equipped with STD 1 inch throwaway filter on 1 inch washable filter.  
Derate ESP by .15 for 2 inch pleated filters.

**TABLE 11  
COOLING PRESSURE – (ALL TEMPERATURES °F)**

Model	Return Air Temperature	Pressure	Temperature (°F)								
			75	80	85	90	95	100	105	110	115
WH421	75 deg. DB	Low Side	74	75	77	78	79	80	80	81	82
	62 deg. WB	High Side	205	220	235	251	266	282	297	313	329
	80 deg. DB	Low Side	79	80	82	83	84	85	85	86	86
	67 deg. WB	High Side	210	226	241	257	273	289	305	321	337
	85 deg. DB	Low Side	85	86	88	89	90	91	91	92	92
	72 deg. WB	High Side	217	233	250	266	283	300	316	333	349
WH483	75 deg. DB	Low Side	72	73	74	76	77	78	79	80	81
	62 deg. WB	High Side	215	229	245	261	278	295	313	332	351
	80 deg. DB	Low Side	77	78	79	81	82	83	84	86	87
	67 deg. WB	High Side	220	235	251	268	285	303	321	340	360
	85 deg. DB	Low Side	80	81	82	84	85	86	87	89	90
	72 deg. WB	High Side	228	243	260	277	295	314	332	352	373
WH602	75 deg. DB	Low Side	70	71	73	74	75	76	78	79	81
	62 deg. WB	High Side	225	233	246	262	282	306	333	364	399
	80 deg. DB	Low Side	75	76	78	79	80	81	83	85	87
	67 deg. WB	High Side	213	239	252	269	289	313	341	373	409
	85 deg. DB	Low Side	81	82	84	85	86	88	90	93	95
	72 deg. WB	High Side	240	248	261	278	299	324	353	386	410

Low side pressure ± 2 psig  
High side pressure ± 5 psig

Tables are based upon rated CFM (airflow) across the evaporator coil. If there is any doubt as to correct operating charge being in the system, the charge should be removed, system evacuated and recharged to serial plate instruction.

**TABLE 12**  
**HEATING PRESSURES – (ALL TEMPERATURES °F)**

Model	Return Air Temperature	Pressure	0	5	10	15	20	25	30	35	40	45	50	55	60
WH421	70 deg.	Low Side	21	25	27	29	32	35	39	43	48	53	58	64	71
		High Side	141	147	152	158	163	169	174	180	190	201	214	229	246
WH483	70 deg.	Low Side	24	26	27	28	29	32	35	39	44	51	58	66	74
		High Side	171	173	176	178	180	184	190	197	205	214	225	237	250
WH602	70 deg.	Low Side	23	25	27	28	30	32	33	35	42	51	62	75	91
		High Side	178	182	185	189	192	194	196	205	218	236	257	283	313

Low side pressure ± 2 psig

High side pressure ± 5 psig

Tables are based upon rated CFM (airflow) across the evaporator coil. If there is any doubt as to correct operating charge being in the system, the charge should be removed, system evacuated and recharged to serial plate instruction.

**TABLE 13**  
**OPTIONAL ACCESSORIES**

Model	Description	WH421-A	WH421-B	WH421-C	WH483-A	WH483-B	WH483-C	WH602-A	WH602-B	WH602-C
EHHW42-A05	Heater Packages	X			X					
EHHW42-A10	Heater Packages	X			X					
EHHW42-A15	Heater Packages	X			X					
EHHW42-C06	Heater Packages			X						
EHHW04-A04	Heater Packages				X					
EHHW04-A05	Heater Packages							X		
EHHW04-A10	Heater Packages							X		
EHHW04-A15	Heater Packages							X		
EHHW04-A20	Heater Packages				X			X		
EHHW04-B09	Heater Packages									
EHHW04-B15	Heater Packages									
EHHW04-B18	Heater Packages					X			X	
EHHW05-B06	Heater Packages		X		X					
EHHW05-B09	Heater Packages		X		X				X	
EHHW05-B15	Heater Packages		X		X				X	
EHHW05A-C09	Heater Packages			X			X			X
EHHW05A-C15	Heater Packages			X			X			X
BOP-5	Blank Off Plate	X	X	X	X	X	X	X	X	X
BFAD-5	Barometric Fresh Air Damper	X	X	X	X	X	X	X	X	X
MFAD-5	Motorized Fresh Air Damper	X	X	X	X	X	X	X	X	X
CRV-5	Classroom Ventilator with Exhaust	X	X	X	X	X	X	X	X	X
EIFM-4	Economizer with Exhaust	X	X	X	X	X	X	X	X	X
WERV-A5B	Energy Recovery Ventilator	X	X		X	X		X	X	
WERV-C5B	Energy Recovery Ventilator			X			X			X
CMH-3	Low Pressure Control (LPC)	X	X			X			X	
CMH-7	Low Ambient Control (LAC)	X	X	X	X	X	X	X	X	X
CMH-9	LAC + LPC	X	X	X	X	X	X	X	X	X
CMH-14	Outdoor Thermostat (ODT)	X	X	X	X	X	X	X	X	X
CMH-15	Start Kit (SK)	X								
WMCB-05B	Circuit Breaker		X							
WMCB-06B	Circuit Breaker					X				
WMPD-01	Circuit Breaker			X			X			X
WMCB-07B	Circuit Breaker								X	
WMCB-09A	Circuit Breaker				X			X		
WMCB-08B	Circuit Breaker	X								