

---

# OIL FURNACE INSTALLATION INSTRUCTIONS

---

## MODELS

FH085D36F  
FLF085D36F  
FLR085D36F  
FLR140D60E

FH110D48E  
FLF110D48E  
FLR110D48E  
FC085D36F

FH110D60E  
FLF110D60E  
FLR110D60E



## WARNING

READ ALL INSTRUCTIONS CAREFULLY BEFORE BEGINNING THE INSTALLATION.

THIS INSTALLATION MUST COMPLY WITH THESE INSTRUCTIONS AND THE REQUIREMENTS OF ALL GOVERNING CODES AND ORDINANCES FOR THE INSTALLATION LOCATION.

IT IS THE RESPONSIBILITY OF INSTALLER TO KNOW AND UNDERSTAND ALL OF THESE REQUIREMENTS.

FAILURE TO DO SO COULD CREATE A HAZARD RESULTING IN PROPERTY DAMAGE, BODILY INJURY OR DEATH.

## FOR YOUR SAFETY

DO NOT STORE OR USE GASOLINE OR OTHER FLAMMABLE VAPORS OR LIQUIDS IN THE VICINITY OF THIS OR ANY OTHER APPLIANCE.

## IMPORTANT NOTICE

THIS FURNACE IS NOT INTENDED FOR USE AS A CONSTRUCTION HEATER. USE OF THIS FURNACE DURING CONSTRUCTION AND FINISHING PHASES OF A STRUCTURE IS CONSIDERED AS "OPERATION IN A CORROSIVE ATMOSPHERE" AND "UNUSUAL, NEGLIGENT OR IMPROPER USE" AND AS SUCH ARE CONSIDERED EXCLUSIONS BY THE BARD MANUFACTURING COMPANY LIMITED WARRANTY.



## WARNING

### CARBON MONOXIDE POISONING HAZARD

FAILURE TO FOLLOW THIS WARNING COULD RESULT IN PERSONAL INJURY OR DEATH.

*Carbon Monoxide is invisible, odorless and toxic! Bard Manufacturing recommends a carbon monoxide alarm in your home, even if you do not own a gas appliance. Locate the carbon monoxide alarm in the living area of your home and away from doorways to attached garages. Follow the alarm manufacturer's instructions included with the alarm.*



CLIMATE CONTROL SOLUTIONS

Bard Manufacturing Company, Inc.  
Bryan, Ohio 43506  
*Since 1914...Moving ahead just as planned.*

Manual: 2100-422I  
Supersedes: 2100-422H  
File: VOL. I, TAB 3  
Date: 07-08-10

# CONTENTS

---

## Getting Other Information and Publications ..... 3

## Installation and Operating Instructions

Equipment Selection .....	4
Locating the Furnace .....	4
Installing the Furnace .....	8
Duct Work .....	8
Installing a Cooling Unit .....	8
Wiring .....	9
Oil Line Piping .....	12
Beckett AFG Oil Burner .....	12 & 13
Beckett "CleanCut" Oil Pump .....	13
Beckett Solid State Igniter .....	13
Beckett R7184B Primary Control .....	13
Beckett R7184B Primary Operational Guide .....	14
Beckett GeniSys 7505 .....	14 – 17
Burner States, Reset Button Op., Priming the Pump, Cad Cell Resistance Indicator, Reset Restricted Lockout	
Burner Set up and Adjustments .....	19, 20 & 21
Short Form Adjustment Procedure .....	21
Combustion Air Requirements .....	25
Louvers and Grilles .....	30
Venting Options .....	30
Thermostat .....	30

## TABLES

Table 1	Minimum Clearances .....	4
Table 2	Dimensions FLF/R Models .....	5
Table 3	Electrical Data .....	9
Table A	Reset Button Operation .....	15
Table B	Status Lights .....	15
Table 4	Furnace Data .....	19
Table 5	Correlation of % of CO <sub>2</sub> , O <sub>2</sub> and Reserve Air .....	24
Table 6	No. 2 Fuel Oil Efficiency Chart .....	24
Table 7	Recommended Start-Up Settings .....	24
Table 8	Sq.Ft. Required as Unconfined Space .....	27
Table 9	Minimum Ventilation Openings .....	28
Table 10	Temperature Rise Ranges, Limit Control Settings, and Heating Blower Speeds .....	31
Table 11	Filter Sizes for Oil Furnaces .....	32

## CHARTS

Chart 1	FH085D36F Data .....	38
Chart 2	FH110D48E Data .....	38
Chart 3	FH110D60E Data .....	38
Chart 4	FLF/FLR085D36F Data .....	38
Chart 5	FLF/FLR110D48E Data .....	38
Chart 6	FLF/FLR110D60E Data .....	38
Chart 7	FLR140D60E Data .....	39
Chart 8	FC085D36F Data .....	39

## Filters

Lo-Boy Models – Filter Locations .....	33
--	----

## Maintenance

Lubrication .....	34
Inspect Air Filter .....	34
Final Inspection and Test .....	34
Service Hints .....	34
Combination Combustion Chamber/Burner Mounting System .....	35
To Remove Burner Only .....	36
To Remove Entire Combustion Chamber Mounting System .....	36
Common Causes of Trouble .....	37
Care of Finish .....	37
Cleaning of the Heat Exchanger .....	37
Blower System Resistance Charts .....	38-39
Wiring Diagrams .....	40-42

## FIGURES

Figure 1	FLF/R Models Dimensions .....	5
Figure 2	FH Models Dimensions .....	6
Figure 3	FC Models Dimensions .....	7
Figure 4	Typical Unit Setup - FLF .....	10
Figure 5	Typical Flue Installation Requirements - FLF .....	11
Figure 6	Typical Single Inside Tank Installation .....	12
Figure 7	Electronic Blower Control .....	18
Figure 8	Typical Smoke-CO <sub>2</sub> Characteristic ..	22
Figure 9	Pressure Gauge Connection to Bleed Port .....	23
Figure 10	Electrode Adjustments .....	25
Figure 11	Combustion Air Boot Assembly .....	26
Figure 12	All Air From Inside Building .....	27
Figure 13	All Air From Outdoors .....	28
Figure 14	All Air From Outdoors Through Ventilated Attic .....	29
Figure 15	All Air From Outdoors - Inlet Air From Ventilated Crawl Space and Outlet Air to Ventilated Attic .....	29
Figure 16	Typical Installation of FR26 and FR27. Filter Rack .....	32
Figure 17	Typical Installation of FR25 Filter Kit .....	32
Figure 18	Filter Installation - Lo-Boy Models ...	33
Figure 19	Removal of Burner Only .....	35
Figure 20	Removal of Entire Combustion Chamber Mounting System .....	36

## GETTING OTHER INFORMATION and PUBLICATIONS

---

These publications can help you install the furnace. You can usually find these at your local library or purchase them directly from the publisher. Be sure to consult current edition of each standard.

National Fuel Gas Code ..... ANSI Z223.1/NFPA54

National Electrical Code ..... ANSI/NFPA 70

Standard for the Installation ..... ANSI/NFPA 90A  
of Air Conditioning and Ventilating Systems

Standard for Warm Air ..... ANSI/NFPA 90B  
Heating and Air Conditioning Systems

Standard for Chimneys, Fireplaces, Vents ..... NFPA 211  
and Solid Fuel Burning Appliances

Load Calculation for ..... ACCA Manual J  
Residential Winter and Summer Air Conditioning

Duct Design for Residential ..... ACCA Manual D  
Winter and Summer Air Conditioning  
and Equipment Selection

### FOR MORE INFORMATION, CONTACT THESE PUBLISHERS:

**ACCA**     **Air Conditioning Contractors of America**  
1712 New Hampshire Ave. N.W.  
Washington, DC 20009  
Telephone: (202) 483-9370  
Fax: (202) 234-4721

**ANSI**     **American National Standards Institute**  
11 West Street, 13th Floor  
New York, NY 10036  
Telephone: (212) 642-4900  
Fax: (212) 302-1286

**ASHRAE**     **American Society of Heating Refrigerating,  
and Air Conditioning Engineers, Inc.**  
1791 Tullie Circle, N.E.  
Atlanta, GA 30329-2305  
Telephone: (404) 636-8400  
Fax: (404) 321-5478

**NFPA**     **National Fire Protection Association**  
Batterymarch Park  
P.O. Box 9101  
Quincy, MA 02269-9901  
Telephone: (800) 344-3555  
Fax: (617) 984-7057

# INSTALLATION and OPERATING INSTRUCTIONS

## EQUIPMENT SELECTION

An accurate heating load calculation must be conducted using American Society of Heating, Refrigeration and Air Conditioning Engineers (ASHRAE) or Air Conditioning Contractors of America (ACCA) manuals. **Do not** add a large safety factor above the calculated value. If the calculated heating load requirement exceeds the heating capacity rating of a given model, use only the next larger size available. Never increase by any more than absolutely necessary based upon available equipment **heating capacities**. Always select based upon heat capacity (output), never use input capacities.

*NOTE: It is the personal responsibility and obligation of the purchaser to contract a qualified installer to assure that installation is adequate and is in conformance with governing codes and ordinances.*

## LOCATING THE FURNACE

When installing the furnace be sure to provide adequate space for easy service and maintenance. Locate the furnace as close to the chimney as practical, giving consideration to the accessibility of the oil burner, controls, and blower for service. Allow a minimum of 24 inches at front of furnace for servicing oil burner. Allow adequate room for filter and blower maintenance. **Clearance from combustible material as stated on the furnace and repeated in Table 1 must be maintained.** For damp basement installations, a raised concrete pad is recommended. This will help keep the bottom of the furnace dry and reduce the risk of rusting.

An oil burner must have a generous supply of combustion air to operate properly. The flow of combustion and ventilating air must not be obstructed from reaching the furnace. See “Combustion Air Requirements” section.

The furnace area must be kept clear and free of combustible materials, gasoline and other flammable vapors and liquids.

This unit is not designed for mobile home or trailer installations. Always install furnace in a level position.

**TABLE 1  
MINIMUM CLEARANCES**

Model	Minimum Installation Clearances — Inches								Minimum Service Clearances		
	Furnace			Plenum		① Duct	Flue Pipe	Floor	Front	Back	Sides
	Front	Back	Sides	Top	Sides						
FH085D36F	4	1	2	2	2	2	9	C	24	—	—
FH110D48E	4	1	2	2	2	2	9	C	24	—	—
FH110D60E	4	1	2	2	2	2	9	C	24	—	—
FLF085D36F	6	0	2	2	2	2	9	NC	24	24	18 *
FLR085D36F	6	18	2	2	2	2	9	NC	24	24	18 *
FLF110D48E	6	0	2	2	2	2	9	NC	24	24	18 *
FLF110D60E	6	0	2	2	2	2	9	NC	24	24	18 *
FLR110D48E	6	18	2	2	2	2	9	NC	24	24	18 *
FLR110D60E	6	18	2	2	2	2	9	NC	24	24	18 *
FLR140D60E	6	18	2	2	2	2	9	NC	24	24	18 *
FC085D36F	6	1	2	2	2	2	9	NC **	24	—	—

① For the first three (3) feet from plenum. After three (3) feet, no clearance required.

C Combustible flooring

NC Noncombustible floor

\* Maintained on one side or the other to achieve filter access and/or blower service.

\*\* Floor must be noncombustible. For furnace only installation can be installed on combustible flooring only when installed on special base part no. CFB7 available from factory. When air conditioning coil cabinet DCB23-22 is used then use special base part no. CFB23.

**FIGURE 1  
FL/R MODELS DIMENSIONS**

**TABLE 2  
FL/R MODELS DIMENSIONS (INCHES)**

Model Number	Cabinet		Plenum Openings		Flue Connection			Air Filters ①	
	A Width	B Depth	C Height	D x E Supply Return	Location	G Dia.	H	J	No. Used
FLF085D36F	23	48.125	36.625	22x20	Front	6	31.625	5.125	16 x 20 x 1
FLR085D36F	23	48.125	36.625	22x20	Rear	6	31.625	5.125	16 x 20 x 1
FLF110D48E	23	48.125	40.625	22x20	Front	6	35.625	5.125	20 x 20 x 1
FLF110D60E	23	48.125	40.625	22x20	Front	6	35.625	5.125	20 x 20 x 1
FLR110D48E	23	48.125	40.625	22x20	Rear	6	35.625	5.125	20 x 20 x 1
FLR110D60E	23	48.125	40.625	22x20	Rear	6	35.625	5.125	20 x 20 x 1
FLR140D60E	26	50.250	47.625	25x20	Rear	6	42.125	---	20 x 25 x 1

① Washable type filter 1" nom. thickness

**FLF/FLR 085, 110 AND 140  
SPECIFICATION SHEET**

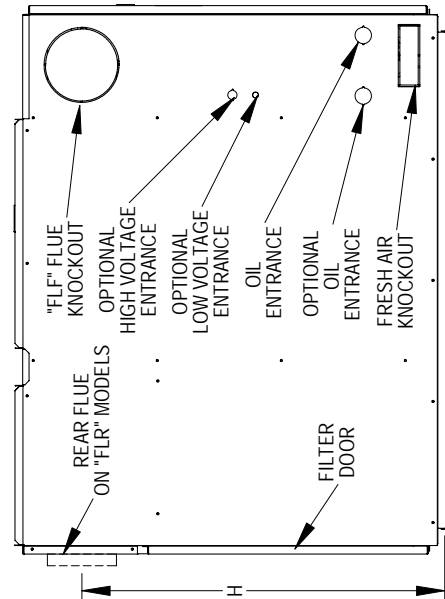
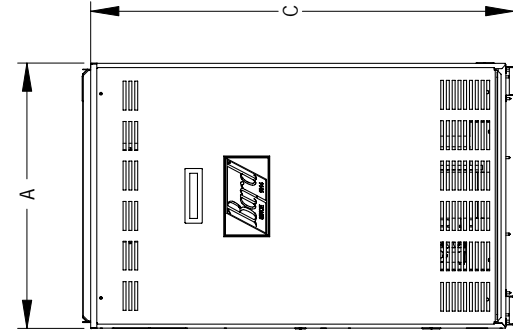
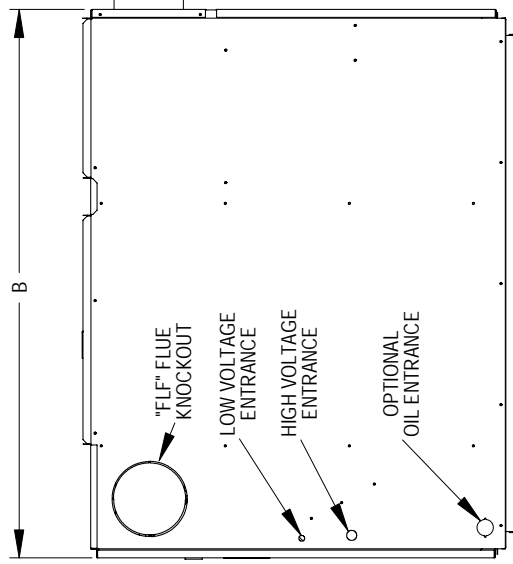
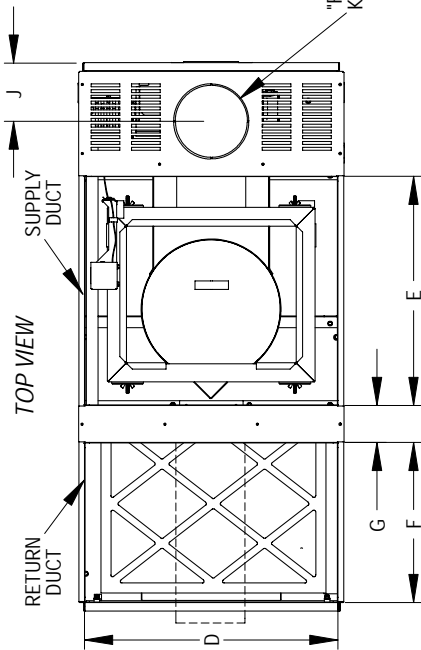

RIGHT SIDE VIEW MIS-1815 A

FRONT VIEW

LEFT SIDE VIEW

# FH085 AND FH110 SPECIFICATION SHEET

**FIGURE 2  
FH MODELS DIMENSIONS**

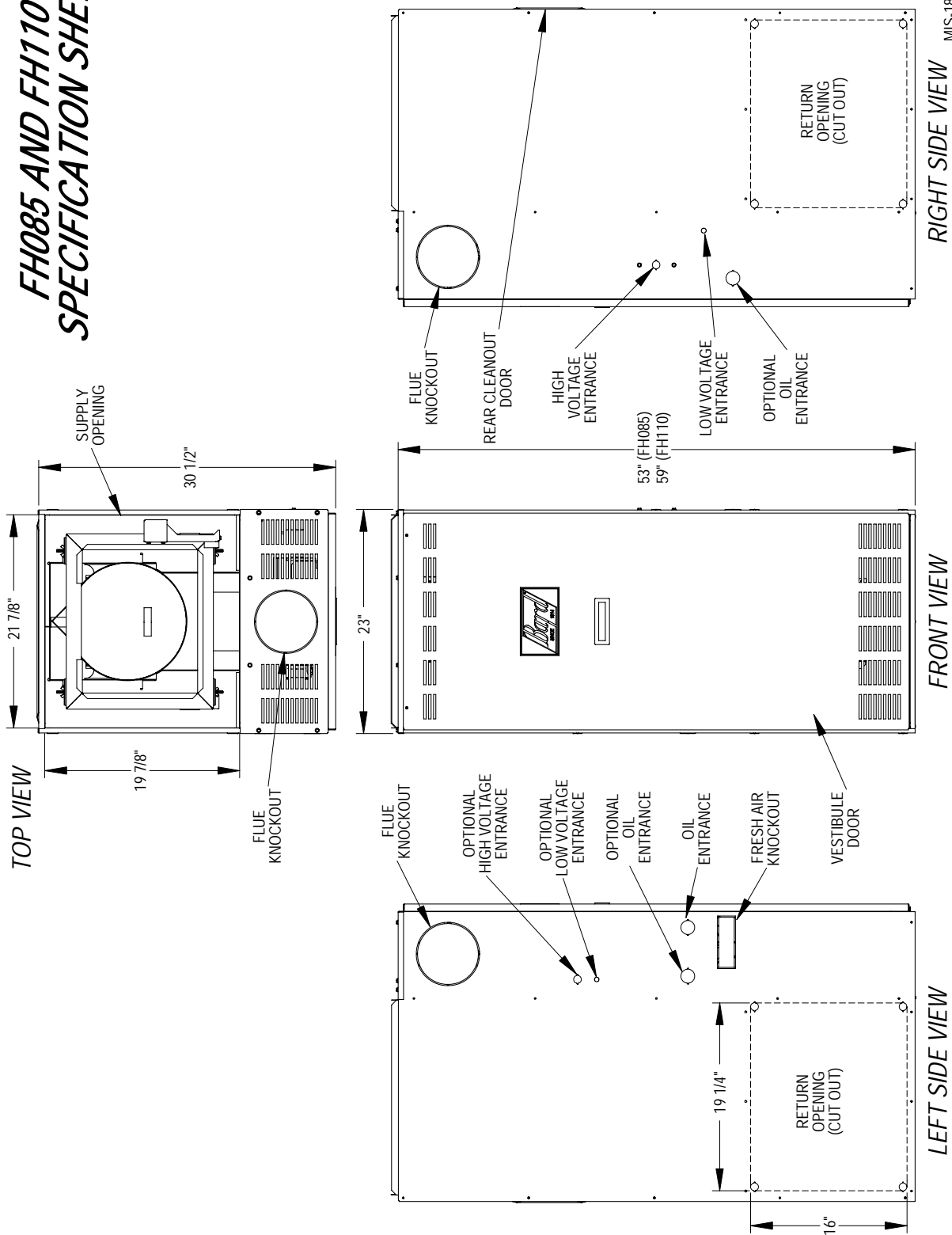

MIS-1814 A

**FIGURE 3  
FC085 MODEL DIMENSIONS**

**COUNTERFLOW  
SPECIFICATION  
SHEET**

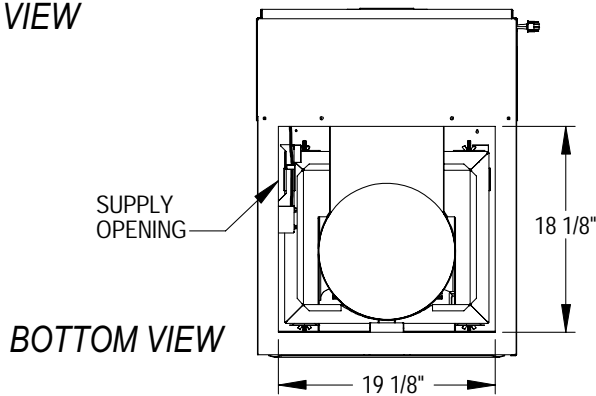
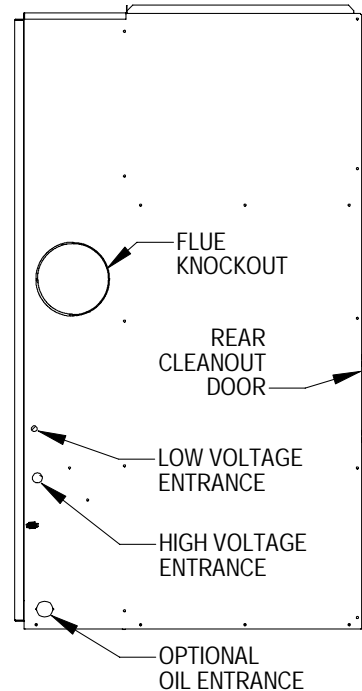
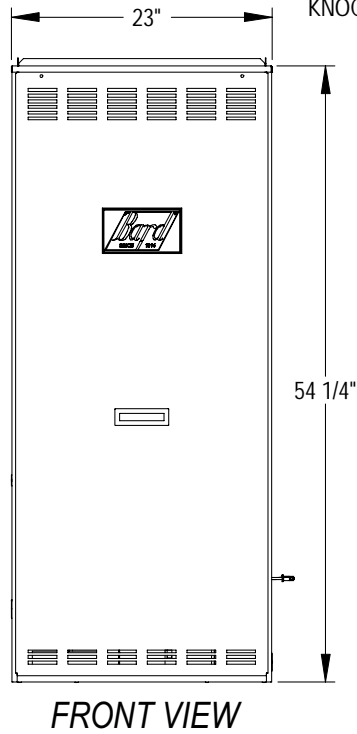
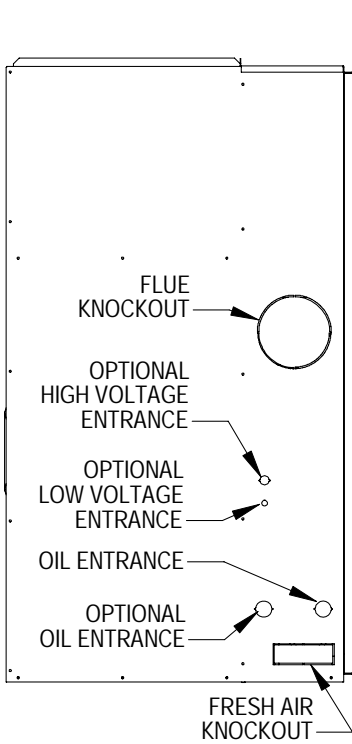
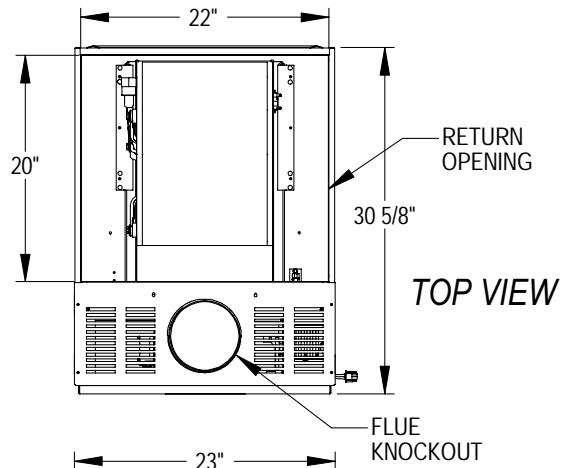

MIS-1826 A



## INSTALLING THE FURNACE

### INSTRUMENTS REQUIRED FOR PROPER SETUP OF THE FURNACE

It is important that a set of instruments capable of the following requirements be used for the setup of this furnace to ensure proper and safe operation:

1. Oil pump pressure gauge that measures up to 150 PSI.
2. Smoke gun to pull smoke samples from flue.
3. Draft gauge that will measure -.02" water column (W.C.)
4. Duct static pressure gauge 0-1.0" W.C. range.
5. Temperature gauge that can read from 50° F up to 700° F.
6. A gauge to measure CO<sub>2</sub> or O<sub>2</sub>.

### INSTALLATION

A typical installation is shown in Figures 4 and 5. All parts of the furnace installation (furnace, oil tank and piping systems, combustion and ventilation air, venting, etc.) must comply with NFPA31, Installation of Oil Burning Equipment -- latest edition. This drawing shows the typical connecting parts needed to correctly install this furnace. Make sure that all parts of the heating system comply with the local codes.

Check the furnace and your load calculation to verify that the unit is properly sized. (Refer to "Equipment Selection" section on Page 4.)

The correct size of unit needed may be substantially smaller than the unit being replaced due to home improvements and technology advancements since the initial installation.

### INADEQUATE SUPPLY AIR and/or RETURN AIR DUCT SYSTEMS

Short cycling because of limit control operation can be created by incorrectly designed or installed supply and/or return air duct systems.

The duct systems must be designed using ASHRAE or ACCA design manuals and the equipment CFM and external static pressure ratings to insure proper air delivery capabilities.

On replacement installations, particularly if equipment is oversized, the duct systems can easily be undersized. Modifications may be required to assure that the equipment is *operating within the approved temperature rise range when under full rated input conditions*, and that no short cycling on limit controls is occurring.

## DUCT WORK

The air distribution system should be designed and installed in conformance with manuals published by Air Conditioning Contractors of America (ACCA) as set forth in Manual D, or ASHRAE publications.

### IMPORTANT

When a furnace is installed so that supply ducts carry air circulated by the furnace to areas outside the space containing the furnace, the return air must also be handled by a duct(s) sealed to the furnace casing and terminating outside the space containing the furnace. This is to prevent drawing possible hazardous combustion products into the circulated air.

### INSTALLING A COOLING UNIT

When the furnace is used in connection with a cooling unit\*, the furnace shall be installed parallel with or on the upstream side of the cooling unit to avoid condensation in the heating element. With a parallel flow arrangement, the dampers or other means used to control flow of air shall be adequate to prevent chilled air from entering the furnace, and if manually operated, must be equipped with means to prevent operation of either unit, unless the damper is in the full heat or cool position.

\* *A cooling unit is an air conditioning coil, heat pump coil or chilled water coil.*

When installing a cooling unit above an FH or FL (below on an FC) series furnace, the coil must be spaced far enough from the furnace outlet to assure proper operation of the furnace. Bard supplied coils, when used with Bard supplied coil cabinets, are automatically positioned.

For top discharge FH and FL models, when coils are installed without using Bard coil cabinets or coils of another brand are used, the coil drain pan should be located a minimum of two (2) inches above the top of the furnace cabinet. If a greater clearance is specified by the coil manufacturer then it would apply.

***NOTE: IF DRAIN PAN IS ANYTHING OTHER THAN A STEEL PAN PARTICULAR ATTENTION MUST BE GIVEN TO THE INSTALLATION INSTRUCTIONS FOR THE COIL TO MAKE SURE IT IS ACCEPTABLE FOR USE WITH THESE OIL FURNACES HAVING MAXIMUM OUTLET AIR TEMPERATURE OF 200° F.***

See CFM versus static pressure curves on pages 38-39 for additional information.



## WIRING

### FACTORY WIRING

All units are fully factory wired. Multispeed blowers are factory wired on high speed for cooling/manual fan operation. Heating speeds are wired for the largest input and may need lower speed for field installed low input nozzle. If replacement wire is necessary, use 105 degrees C minimum. See electrical data, Table 3.

### FIELD WIRING

All wiring must conform to the National Electrical Code and all local codes. A separate fuse or breaker should be used for the furnace.

**TABLE 3  
ELECTRICAL DATA**

Model	Volts-HZ-PH	Total Amps	Blower Motor		Burner Motor		Minimum Circuit Ampacity	Max. Time Delay Fuse or HACR Circuit Breaker
			HP	FLA	HP	FLA		
FH085D36F	115-60-1	9.2	1/3	7.5	1/7	1.7	15	15
FH110D48E	115-60-1	12.2	1/2	10.5	1/7	1.7	16	20
FH110D60E	115-60-1	14.2	3/4	12.5	1/7	1.7	19	20
FLF085D36F	115-60-1	17.3	1/3	5.6	1/7	1.7	15	15
FLR085D36F	115-60-1	17.3	1/3	5.6	1/7	1.7	15	15
FLF110D48E	115-60-1	12.2	1/2	10.5	1/7	1.7	16	20
FLR110D48E	115-60-1	12.2	1/2	10.5	1/7	1.7	16	20
FLF100D60E	115-60-1	14.2	3/4	12.5	1/7	1.7	19	20
FLR100D60E	115-60-1	14.2	3/4	12.5	1/7	1.7	19	20
FLR140D60E	115-60-1	14.2	3/4	12.5	1/7	1.7	19	20
FC085D36F	115-60-1	7.3	1/3	5.6	1/7	1.7	15	15

**FIGURE 4  
TYPICAL UNIT SETUP  
FLF UNIT SHOWN**

**WARNING**  
ALL WIRING MUST  
CONFORM TO THE  
NATIONAL ELECTRIC  
CODE AND ALL LOCAL  
CODES.

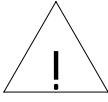
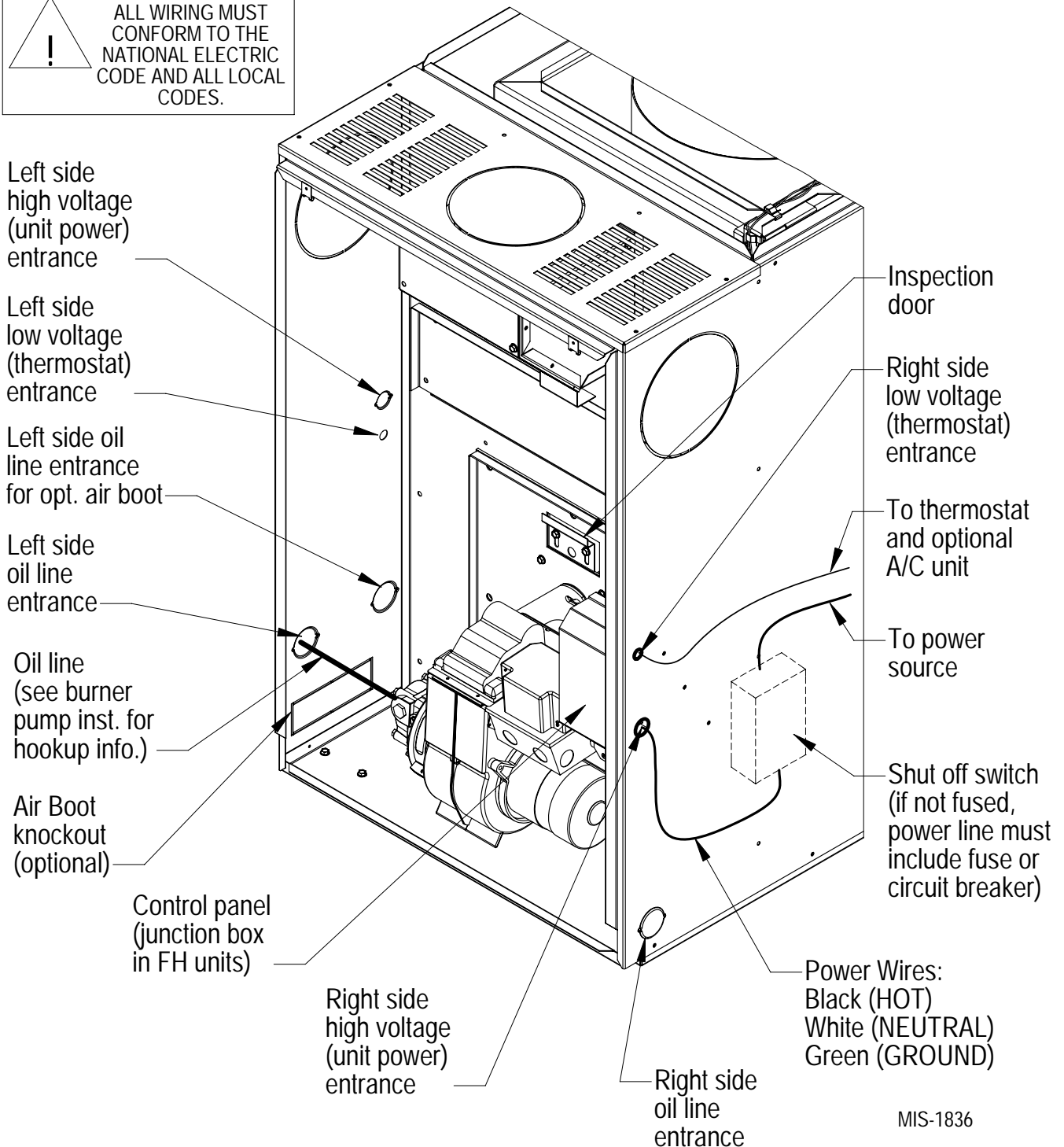
MIS-1836

**FIGURE 5**  
**TYPICAL FLUE INSTALLATION REQUIREMENTS**  
**FRONT FLUE LO-BOY MODEL SHOWN**  
**(REPRESENTS ALL MODELS)**

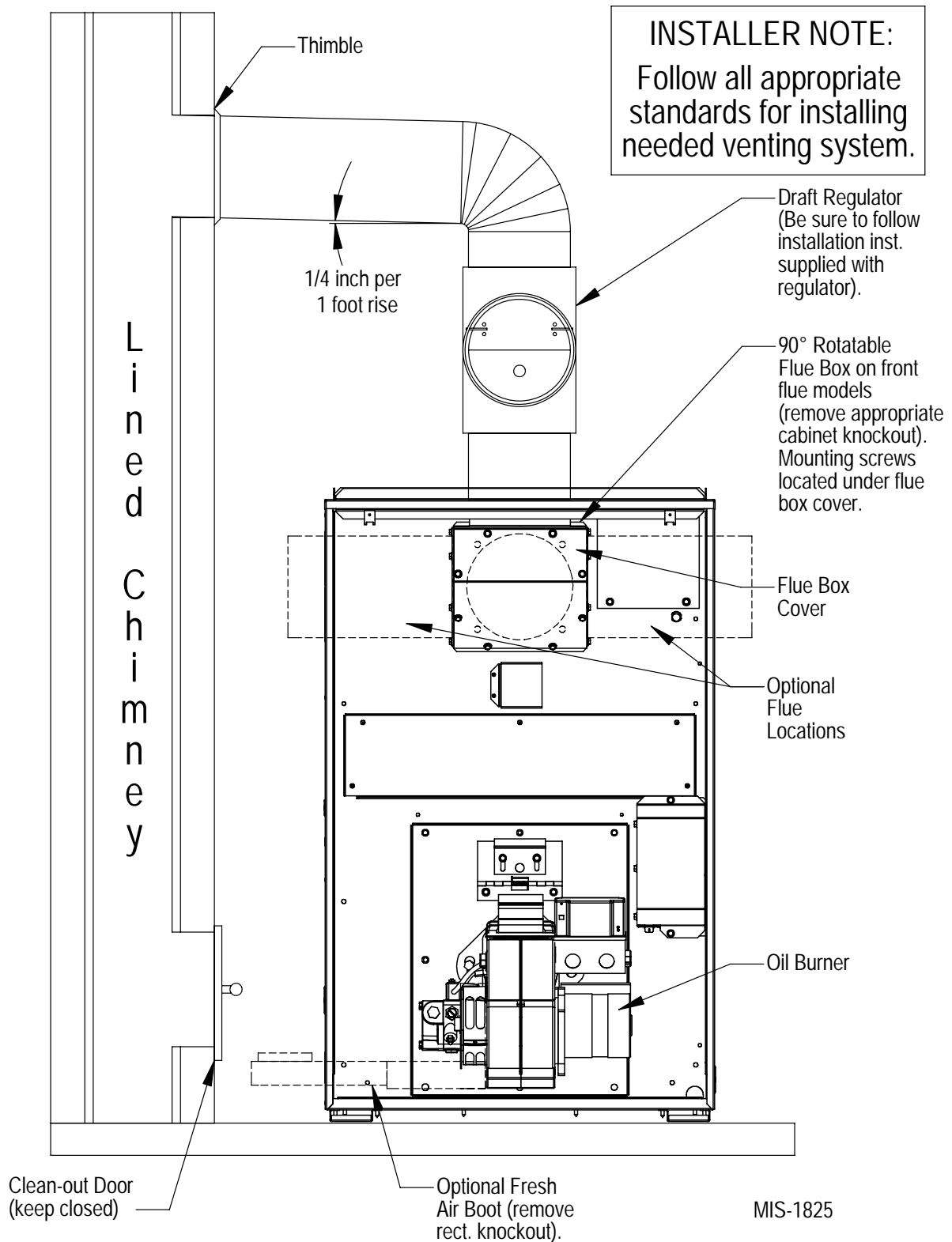

## OIL LINE PIPING

First determine whether the pipe system is to be a single line system or a two line system. All connections must be absolutely air tight or you will have a malfunction of the burner. When installing the piping, a good oil filter should be installed close to the burner. A single line system is recommended for gravity feed.

A typical single inside tank installations shown in Figure 6. For installation details for this and other tank configurations, refer to NFPA31 -- latest edition. All tank and pipe setups must comply with NFPA31.

## BECKETT AFG OIL BURNER

This furnace is equipped with a high static Beckett AFG oil burner which is designed to produce adequate draft in nearly any vertically vented application. The burner employs the latest time tested controls of the highest quality. The controls consist of a high voltage Beckett solid state igniter, a Beckett "CleanCut" oil pump with an integral solenoid valve, and a Beckett R7184B primary control.

**FIGURE 6  
TYPICAL SINGLE INSIDE TANK INSTALLATION**

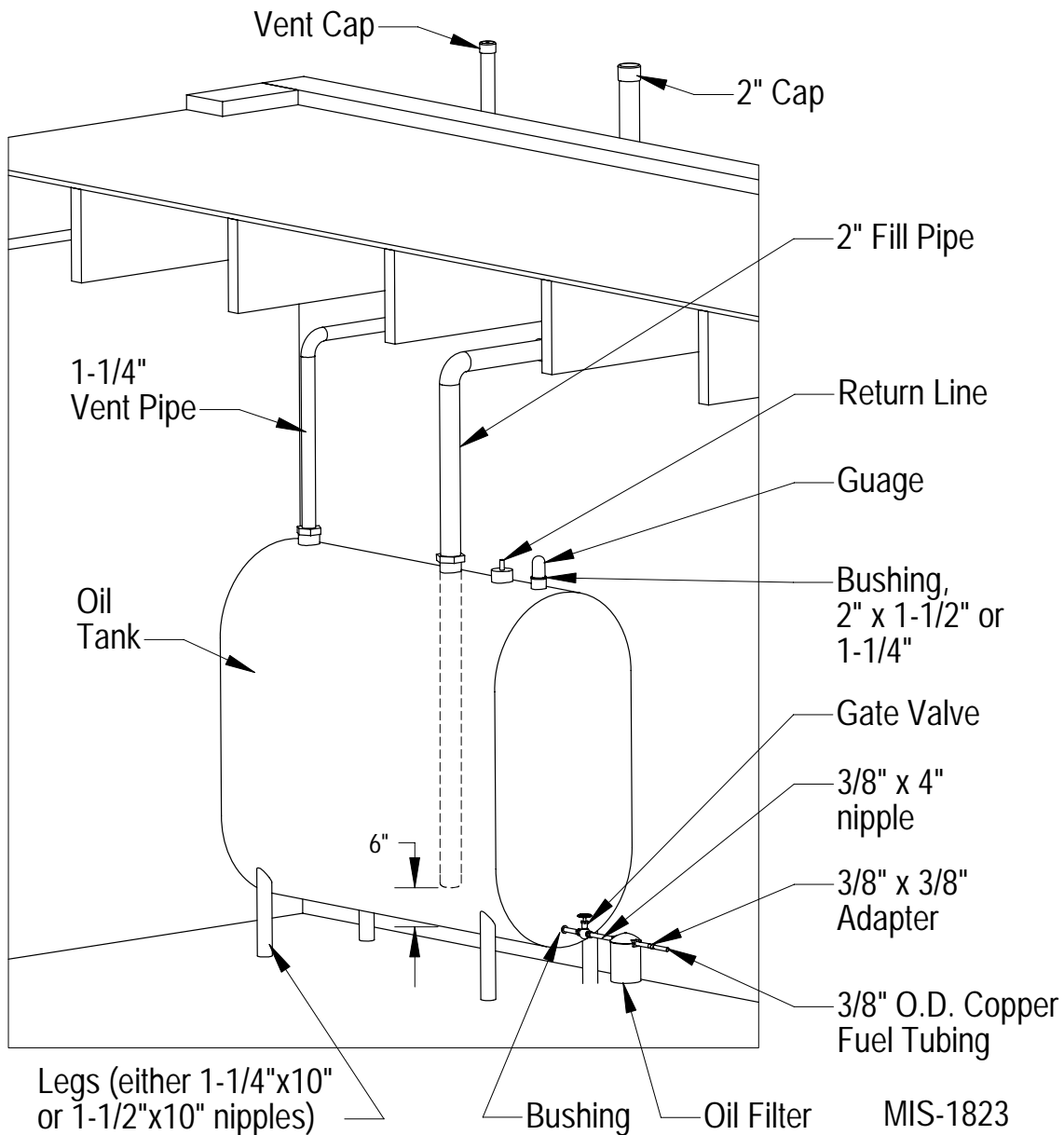

These controls were selected for their proven high quality, dependability, and serviceability. With proper maintenance this burner assembly will provide many years of reliable service.

All units are shipped with the oil burner installed, and with high rate oil nozzle installed designed for use with No. 1 or No. 2 fuel oil. **Inspect firepot refractory before firing to be sure it has not been jarred out of position in shipment. Burner air tube *must not* extend beyond inside surface of firepot. Burner head should be centered on the combustion chamber opening.** See Figures 19 and 20.

## **WARNING**

Never attempt to use gasoline in your furnace. Gasoline is more combustible than fuel oil and could result in a serious explosion causing damage, injury or death.

The following is a detailed explanation of each control included in the Beckett AFG Oil Burner, how each operates, how to set up the burner, and how to troubleshoot problems should they occur.

### **BECKETT “CLEANCUT” OIL PUMP**

This oil pump is equipped with an oil solenoid valve installed in the pump housing. This feature provides quick cutoffs resulting in reduction in smoke after the burner shuts down. This is a time proven pump design and is capable of both one and two pipe systems. This pump *requires* a pre-purge style primary control such as the R7184B primary. All installation and set up instructions are outlined in the “Oil Pump Specification” section of the installation instructions manual.

### **BECKETT SOLID STATE IGNITER**

This igniter differs from the traditional iron core transformer in that it produces a 14,000 volt spark instead of a 10,000 volt spark of the iron core transformer. This hotter spark provides for cleaner, faster ignitions. Being solid state technology this igniter is less susceptible to problems caused by voltage variations. It also has a greater ability to ignite cold and/or inconsistent oil. The solid state igniter is wired to the primary control the same as an iron core transformer.

### **BECKETT R7184B PRIMARY CONTROL**

The R7184B Interrupted Electronic Oil Primary is a line voltage, safety rated, interrupted ignition oil primary control for residential oil burners. The R7184B used with a cad cell flame sensor, operates the oil burner and oil valve. The primary controls fuel oil, senses flame, controls ignition spark and is designed to notify a remote alarm circuit before going into lockout when equipped with a flame monitoring system.

This primary control possesses the latest technology, is a very simple control to operate and provides additional troubleshooting features to ease service and reduce down time. The operational guide for the R7184B primary control is provided following on Page 14.

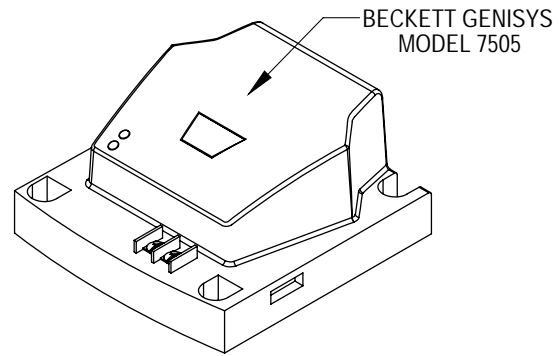
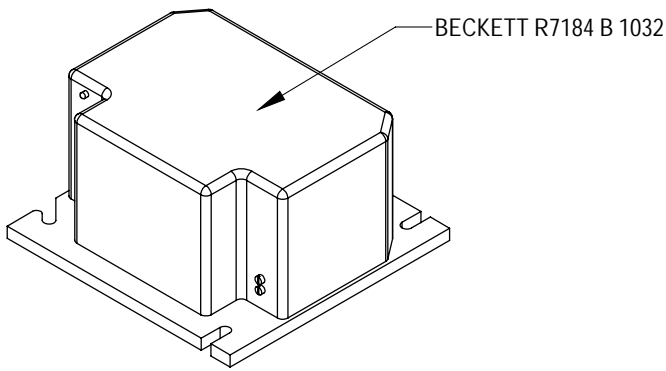

MIS-2491

## PRIMARY OPERATIONAL GUIDE

### BECKETT R7184B

**Pre-Purge Delay** – 15 seconds on delay

**LED Codes** –

- *Flashing 1/2 second on / 1/2 second off* – system is locked out or in restricted mode (hard lockout).
- *Flashing 2 seconds on / 2 seconds off* – control is in recycle mode (soft lockout).
- *ON* – CAD cell is sensing flame
- *OFF* – CAD cell is not sensing flame.

**Ignition Trials** – On any given call for heat the control will allow three ignition trials. After the three trials the control will go into a *soft lockout* mode. The LED will flash 2 seconds on and 2 seconds off when in this recycle mode. The control may then be reset by pressing the RED reset button on the control. If within the same original call for heat the control will again allow three ignition trials followed by another *soft lockout* and a 2 second on / 2 second off LED code. The control may be reset one additional time by pressing the red reset button. This will allow three final ignition trials. If all three of the final ignition trials fail then the control goes into a *hard lockout* or *Restricted Mode*. This series of ignition failures must all occur with the original call for heat in order to reach the *Restricted Mode*. The LED will now flash 1/2 second on / 1/2 second off indicating the *restricted mode*. The control can be resurrected from the restricted mode only by pressing and holding the red reset button for approximately 30 seconds until the LED flashes twice. Removing unit power or resetting the thermostat will not reset the control.

**Checking CAD Cell** – With a call for heat and the burner ignited, press and release the red reset button. The LED will go out and then flash 1, 2, 3, or 4 times before returning to the run mode. The CAD cell resistance must be below 1600 ohms for proper operation.

- *1 flash* – Less than 400 ohms
- *2 flashes* – More than 400 and less than 800 ohms
- *3 flashes* – More than 800 and less than 1600 ohms
- *4 flashes* – More than 1600 and less than 5000 ohms

### BECKETT GENISYS 7505

**Sequence of Operation**

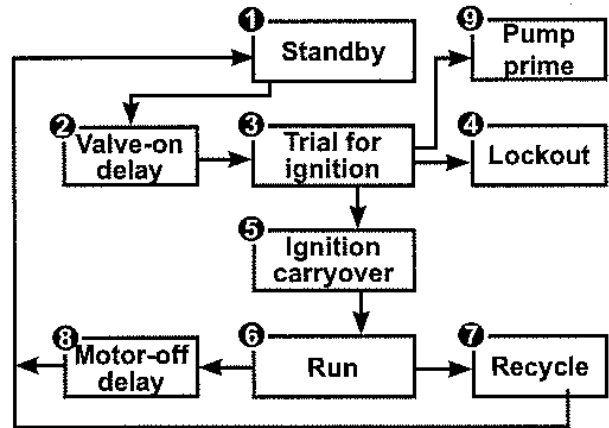

### BURNER STATES

- 1. Standby:** The burner is idle, waiting for a call for heat.
- 2. Valve-On Delay (Prepurge):** The igniter and motor are on while the control delays turning on the oil solenoid valve for the programmed time.
- 3. Trial for Ignition:** The fuel valve is opened. A flame should be established within the factory set trial for ignition time (“lockout time”).
- 4. Lockout:** The control has shut the burner down for one of the following safety reasons:

- The trial for ignition (lockout) time expires without flame being established.
- The cad cell detects flame during Valve-On Delay.
- The Recycle mode 30-second time budget expires (see "Recycle" section for complete explanation of recycle time budget).

If the control locks out three times without completing a successful call for heat, the control enters Restricted (Hard) Lockout, and must be reset by a technician. Hold the reset button for 15 seconds until the red light shuts off to reset from Restricted Lockout.

- 5. Ignition Carryover:** Once flame is established, the igniter remains on for 10 additional seconds to ensure flame stability.
- 6. Run:** The flame is sustained until the call for heat is satisfied. The burner is then sent to Motor-Off Delay (Postpurge), if applicable, or it is shut down and sent to Standby.

**7. Recycle:** If the flame is lost while the burner is firing, the control shuts down the burner, enters a 60-second recycle delay and then repeats the ignition sequence. The control will continue to Recycle each time the flame is lost until the accumulated oil-flow-without-flame time reaches 30 seconds, at which point the control will go into lockout. This feature prevents excessive accumulation of oil in the appliance firing chamber.

**8. Motor-Off Delay:** If applicable, the fuel valve is closed and the control delays turning the motor off for the set motor-off delay time before the control returns to standby.

**9. Pump Prime:** The igniter and motor are on with the oil valve open for up to 4 minutes. During Pump Prime mode, the cad cell is disregarded, allowing the technician to prime the pump without having to jumper the cad cell.

#### RESET BUTTON OPERATION

- **Table A** below explains what action the control will take when the reset button is pressed for different lengths of time during the various burner operating states.

**TABLE A  
RESET BUTTON OPERATION**

If the burner is in the below state:	Pushing the Reset button will:		
	Button Click (press < 1 second)	Button Hold (press > 1 second)	Button Hold (press 15+ seconds)
Lockout	Reset from Soft Lockout		Reset from Restricted (Hard) Lockout
Valve-on Delay, Trial for Ignition, Ignition Carryover	Go to Pump Prime (see Below)	Disable the Burner: Any time the burner is running, press and hold the reset button to disable the burner. The burner will remain off as long as the button is held.	Enables Pump Priming: After the reset button has been held for 15 seconds, the button can then be tapped during the next ignition sequence to enter Pump Prime mode.
Run (igniter is shut off)	Yellow LED flashes to indicate cad cell resistance. See "Cad Cell Resistance Indicator" for table of resistance values.		
Motor-Off Delay, Standby	No action		
Pump Prime	No action	Exit Pump Prime mode and return to Standby	

**TABLE B  
STATUS LIGHTS**

LED Color	On Continuously	Flashing
Red	Restricted (hard) Lockout	Soft Lockout
Green	Flame Detected (Could be flame or stray light)	Recycle
Yellow	Control is in Pump Prime mode <i>or</i> Reset button currently held for 15+ seconds	Cad Cell resistance. See "Cad Cell Resistance Indicator" section for table of resistance values.



## PRIMING THE PUMP



# WARNING

### Hot Gas Puff-Back & Heavy Smoke Hazard

***Failure to bleed the pump properly could result in unstable combustion, hot gas puff-back and heavy smoke.***

- Do not allow oil to spray into a hot combustion chamber while bleeding air from the pump.
- Install a gauge in the nozzle discharge port tubing or fully open the pump bleed valve to prevent oil spray from accumulating in the combustion chamber during the air bleed procedure.
- Ensure that all bubbles and froth are purged from the oil supply system before tightening the pump air bleed valve.

1. Prepare the burner for priming by fully opening the pump bleed port and attaching a clear plastic hose over the bleed port fitting. Use a suitable container to collect purged oil.
2. Initiate a call for heat.
3. After the burner starts, press and hold the reset button for 15 seconds until the yellow LED turns on. This indicates that the button has been held long enough.
4. Release the reset button. The yellow LED will turn off and the burner will start up again.

5. At burner start up, tap the reset button within the first 10 seconds of the ignition cycle. This will transition the control to a dedicated Pump Prime mode, during which the motor, igniter and valve are powered for four minutes. The yellow LED will be on.
6. Bleed the pump until all froth and bubbles are purged. If desired, hold the reset button for at least one second to exit Pump Prime mode and return to Standby.
7. At the end of 4 minutes, the yellow LED will turn off and the control will automatically return to standby mode.
8. If prime is not established during the four minute pump prime mode, return to step 5 to re-enter Pump Prime mode. Repeat steps 5 through 7 until the pump is fully primed and the oil is free of bubbles.
9. Terminate the call for heat, and the control will resume normal operation.

## CAD CELL RESISTANCE INDICATOR

- During the burner Run state, tap the reset button (less than 1 second) to check the cad cell resistance range. The yellow LED will flash 1 to 4 times depending on the amount of light detected by the cad cell. See chart below:

Yellow LED Flashes	Flame Detection Range
1	Normal (0 - 400 ohms)
2	Normal (400 - 800 ohms)
3	Normal (800 - 1600 ohms)
4	Limited (1600 ohms - Lockout)

## RESETTING FROM RESTRICTED LOCKOUT

- If the control locks out three times without a satisfied call for heat, or due to other significant events such as a relay contact weld, the Lockout becomes *restricted* in order to prevent repetitious resetting by the homeowner.



- Then, to reset, hold the button down for 15 seconds until the red light turns off and the yellow LED turns on. Observe at least one full control sequence of operation from startup to shutdown. Simulate a flame failure lockout by following the procedure (within this manual). If the operation is erratic, or not to specifications, then replace the control. Always verify the control functions according to all specifications before leaving the installation site.

## DISABLE FUNCTION

- Any time the burner is running, press and hold the reset button to disable the burner. The burner will remain off as long as the button is held.

## Burner Option – Flame Quality Monitor

This control is trained to recognize and remember a good flame based on initial burner set up. Control then monitors the flame via the CAD cell signal for deviation in the combustion characteristics of the burner. If the control senses a deviation on the high side or on the low side from the original set up condition for three consecutive cycles, it will trigger an alarm circuit which can be tied to an audible local device to signal the home owner or into the home security system. Upon being notified of the alarm, the security agency will notify the dealer of choice based upon information supplied by the home owner. The system will also be capable of being connected to a phone line that will contact the dealer directly with the alarm. This alarm will typically sound 3 to 5 days prior to the primary control going into lockout giving the service agency a prior notice before a sooting condition or other failure can occur resulting in untold savings. This monitor system is available through your local distributor under the Honeywell Part #QS7100F.

## Electronic Blower Control Board (EBC)

This furnace is equipped with an Electronic Blower Control (EBC), which controls all comfort air blower operations. This EBC has three relays; one for heating speed, one for cooling speed, and one which isolates the T–T signal from the oil primary control.

**NOTE:** *If a jumper wire is placed across “R” and “W” prior to turning on power to the unit and then power is applied, the comfort air blower will start and run for the ignition period and through the entire call for heat.*

**Once this call for heat is satisfied, the blower will function according to the regular blower on and blower off delay cycles.**

This EBC is designed to be very simple and dependable. This basic control allows for easy troubleshooting and maintenance. As illustrated in Figure 7 all connections are well marked. The blower on and off timings for both heating and cooling speeds are timed automatically. The heating blower off delay can be selected from four different timings by moving the selection jumper. The timings are as follows:

Heating Blower ON delay – 75 seconds from a call for heat.

Heating Blower OFF delay – Selectable in seconds: 150, 180, 210 or 240. Factory shipped at 240.

Cooling Blower ON delay – 6 seconds from a call for cooling.

Cooling Blower OFF delay – 60 seconds.

**FIGURE 7  
ELECTRONIC BLOWER CONTROL**

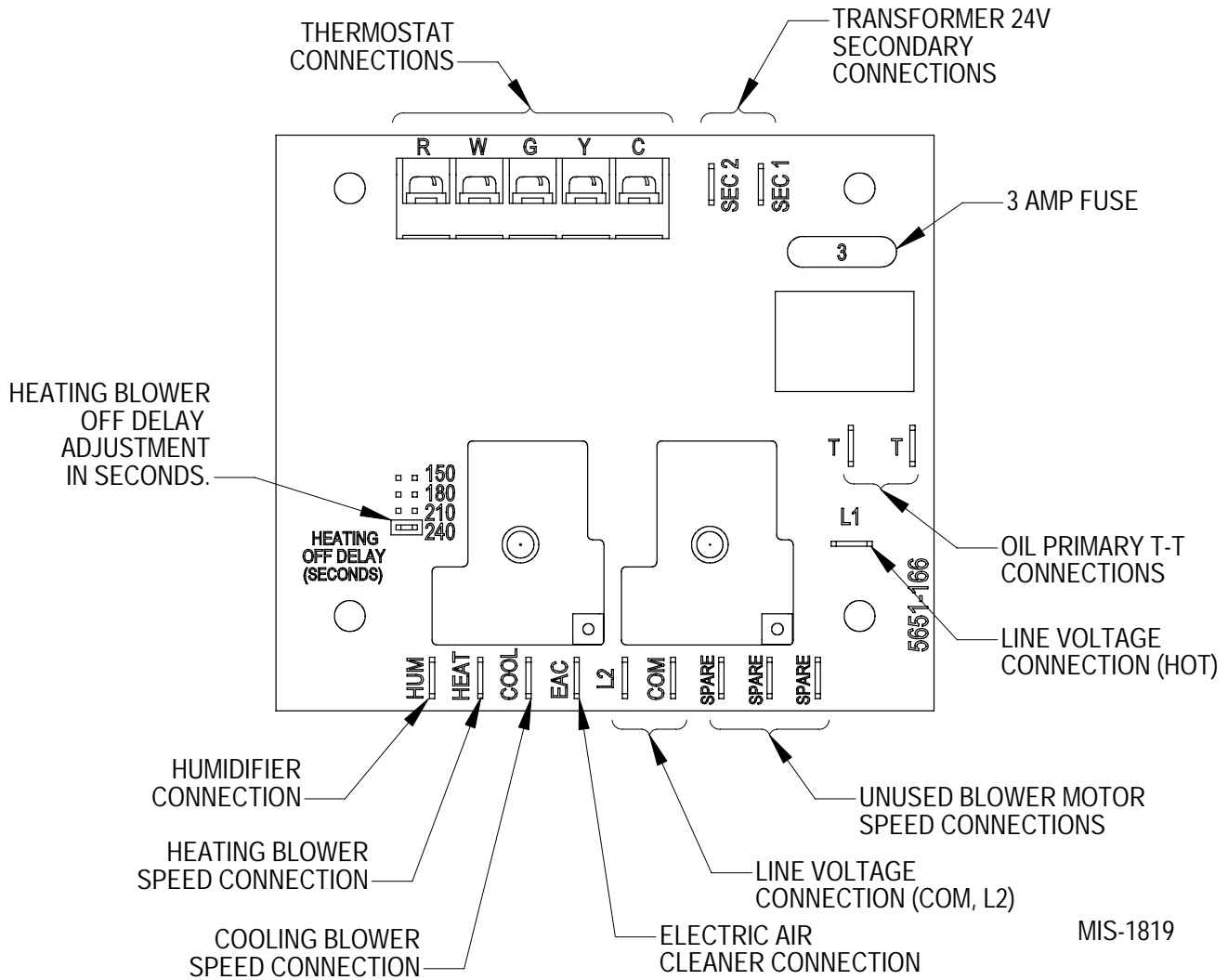

**TABLE 4  
FURNACE DATA**

Model Number	Furnace Installed Standard			Field Installed Options					
	① Nozzle Size	Input BTUH	② Heating Capacity BTUH	① Nozzle Size	Input BTUH	② Heating Capacity BTUH	① Nozzle Size	Input BTUH	② Heating Capacity BTUH
FLF085D36F	.75	105,000	85,000	.65	91,000	74,000	.55	77,000	63,000
FLR085D36F	.75	105,000	85,000	.65	91,000	74,000	.55	77,000	63,000
FLF110D48E	1.00	140,000	113,000	.85	119,000	96,000	NA	NA	NA
FLR110D48E	1.00	140,000	113,000	.85	119,000	96,000	NA	NA	NA
FLF110D60E	1.00	140,000	113,000	.85	119,000	96,000	NA	NA	NA
FLR110D60E	1.00	140,000	113,000	.85	119,000	96,000	NA	NA	NA
FLR140D60E	1.25	175,000	142,000	1.10	154,000	125,000	NA	NA	NA
FC085D36F	.75	105,000	85,000	.65	91,000	74,000	.55	77,000	63,000
FH085D36F	.75	105,000	85,000	.65	91,000	74,000	.55	77,000	63,000
FH110D48E	1.00	140,000	113,000	.85	119,000	96,000	NA	NA	NA
FH110D60E	1.00	140,000	113,000	.85	119,000	96,000	NA	NA	NA

① 70 degree hollow cone spray pattern, 100 PSIG pump pressure

② Annual fuel utilization efficiency and heating capacity based upon U.S. Government standard test using D.O.E. isolated combustion rating procedure.

## BURNER SETUP AND ADJUSTMENT PROCEDURES

All oil burner installations should be performed by a qualified installer in accordance with regulations of the National Fire Protection Standard for Oil-Burning Equipment, NFPA31 -- latest edition, and in complete compliance with all local codes and authorities having jurisdiction. A qualified installer is an individual or agency who is responsible for the installation and adjustments of the heating equipment and who is properly licensed and experienced to install oil-burning equipment in accordance with all codes and ordinances.

The proper installation and adjustment of any oil burner requires technical knowledge and the use of combustion test instruments. The following procedure must be followed to correctly adjust the burner to match the specific characteristics of the installation.

### IMPORTANT

Always use combustion test instruments when making burner adjustments and draft gauge when setting the barometric damper. It is virtually impossible to make accurate and reliable adjustments using the "eyeball" method.

Check all oil lines and connections for leaks.

Connect pressure gauge by removing bleed fitting and screwing in pressure gauge. See Figure 9.

## 1. PREPARATION STEPS

- A. **Calibrate and Check Operation of Measuring Equipment** Follow manufacturer's recommended procedures for calibration and equipment check out.
- B. **Prepare Heating Unit for Testing** Drill two 1/4 inch holes in the flue between the heating plant and the barometric draft regulator. If space permits, the holes should be located in a straight section of the flue, at least two flue diameters from the elbow in the flue pipe and at least one diameter from the draft regulator. The purpose of the two holes in the flue pipe is to speed up testing and reduce instrument handling.
- C. **Clean and Seal Heating Plant** Make sure the burner blast tube, fan housing, and blower wheel are clear of dirt and lint. Seal any air leaks into the combustion chamber.
- D. **Nozzle Inspection** Annual replacement of nozzle is recommended. The nozzle size should match the design load. **DO NOT OVERSIZE.** (Determination of oversizing can be determined prior to your adjustment. If the firing rate should be reduced refer to Table 4.) Short cycles and low percent on: time result in higher overall pollutant emissions and lower thermal efficiency. An in-line oil filter will reduce service problems due to nozzle clogging.

It should be located as close as possible to the oil burner. Care should be taken to prevent air leakage in the oil suction line. Use continuous runs of copper tubing and use minimum number of joints and fittings. Always use flare fittings.

- E. **Adjustment of Electrodes** Adjust ignition electrodes as specified in Figure 10.
- F. **Operate Burner** Operate burner, adjust air setting for good flame by visual observation, and run for at least 10 minutes or until operation has stabilized.
- G. **Check Burner Pressure** Bleed air from pump and nozzle piping. Check pump pressure and adjust to 100 psi, if necessary.

## 2. COMBUSTION ADJUSTMENT STEPS

- H. **Set Draft** Check the draft reading over the fire with a draft gauge through a hole in the inspection door. The hole is above the flame level. Adjust the barometric draft regulator on the flue to give the over fire of  $-.02$ " W.C.
- I. **Check Smoke Readings** After burner has been operating 5 or 10 minutes, make a smoke measurement in the flue, following the smoke tester instructions. Oily or yellow smoke spots on the filter paper are usually a sign of unburned fuel, indicating very poor combustion (and likely high emissions of carbon monoxide and unburned hydrocarbons). This condition can sometimes be caused by too much air, or by other factors. If this condition cannot be corrected, major renovation or even burner replacement may be necessary.
- J. **Develop Smoke - CO<sub>2</sub> Curve** Record measurements of smoke and CO<sub>2</sub> from the flue. Then establish the smoke - CO<sub>2</sub> curve by taking readings over a range of air settings, as shown in Figure 8.

To do this, start with the air gate set at nearly full open and then take smoke and CO<sub>2</sub> readings at progressively lower air settings, as necessary to visualize the general shape of the curve. (The CO<sub>2</sub> readings will increase as the air setting is decreased, unless combustion is incomplete.) Do not set the air gate to give a smoke reading above No. 4 or No. 5. Plot the points on graph paper, as in Figure 8. Usually 3 or 4 readings are enough to establish the curve.

In adjusting each air setting, it is helpful to note the various positions of air gate at which measurements are made so that the final setting can be located quickly.

- K. **Adjust Air Setting** Examine the smoke - CO<sub>2</sub> plot and, keeping in mind the curve of Figure 6, note the location of the "knee" where the smoke number begins to rise sharply. Noting the air gate position marks, adjust the air setting to a CO<sub>2</sub> level 1/2 to 1 percent lower than the CO<sub>2</sub> level at the "knee". (This provides a tolerance against possible shifts in the setting over a period of time.) Do not increase the air setting any more than necessary on the lower portion of the curve below the "knee".

The characteristic curve for some burners may not yield a distinct "knee" in the curve. In such cases, the setting should be made near the minimum smoke, (using judgement).

**Lock the air adjustment and repeat draft, CO<sub>2</sub> and smoke measurements to make sure the setting has not shifted.**

## 3. COMBUSTION DIAGNOSIS

- L. **Check Performance** A well-matched and well-tuned burner should be capable of operation with smoke not greater than No. 2 and at a CO<sub>2</sub> level not less than 10%.

If this cannot be reached, check the following:

1. Air leaks into the combustion chamber or heat exchanger can dilute the combustion gases and prevent normal CO<sub>2</sub> readings. Such leaks should be sealed with furnace cement or other high-temperature sealant.

To check for dilution by leakage, measure the CO<sub>2</sub> at as high a point as possible over the fire, using a stainless steel tube inserted through the fire door sample hole (as described earlier for overfire draft measurements), and compare this with the CO<sub>2</sub> measured in the flue. A difference of more than 1 percent CO<sub>2</sub> between the flue and overfire reading usually indicates air entry through leaks that have not been properly sealed.

Seal between the probe and inspection door sample hole during test. The inspection door hole should be sealed when not being used to avoid leakage of air through it. (See Step H.)

2. If the CO<sub>2</sub> level of 10% cannot be reached without exceeding No. 2 smoke, poor mixing of air and fuel is likely.

It may be necessary to replace the combustion head or try different settings.

#### 4. FINAL CHECKS

M. **Measure Stack Temperature** Operating the unit at an excessive firing rate will generate more heat than the heat exchanger can utilize and result in unnecessary heat loss up the chimney. Other causes of excessive heat loss are badly sooted heat exchanger surfaces and excessive draft. The temperature of the flue gas provides an indication of these heat losses.

Measure flue temperature by subtracting the room air temperature from the thermometer reading. Excessive stack loss is indicated if the net stack temperature during steady operation exceeds 600° F.

N. **Check Ignition** Check operation over repeated cycles to insure prompt ignition on starting.

O. **Check Pump Cutoff** Slow pump cutoff at the end of a firing cycle can cause smoke and other pollutant emissions. Check for prompt pump cutoff by observing flame or by testing smoke at shutdown. If poor cutoff is observed, make sure air is purged from the pump and nozzle line. Air trapped in the pump or nozzle line will expand when heated, thus causing oil to drip into the combustion chamber after shutdown. If poor cutoff persists, repair or replace pump. Also make sure the pump solenoid is working - if not replace.

#### SHORT FORM ADJUSTMENT PROCEDURE

Some burner service organizations may wish to perform a shorter procedure for the adjustment of oil burners. The following is an example of such a short form prepared by the National Association of Oil Heat Service Managers.

##### 1. SERVICE AND CLEAN BURNER

Follow company procedure to complete the cleaning and servicing. Operate burner for ten minutes while tools are gathered and are cleaned.

##### 2. CHECK DRAFT

Set draft regulator, if necessary. Regulator should be adjusted to achieve a -.02" W.C. over fire condition. The more restricted and lengthy the flue, the higher the draft necessary to obtain the accepted over fire conditions.

##### 3. SMOKE TEST

Follow the instructions of the manufacturer of the smoke tester and take a smoke sample. Adjust the air to obtain a preliminary reading of about No. 3 spot. Then readjust the air to obtain the lowest possible reading, but do not open the air adjustment more than absolutely necessary to obtain a trace or No. 0 spot.

##### 4. CO<sub>2</sub> TEST

Check CO<sub>2</sub> levels. This level should be between 10% and 12%.

**FIGURE 8**  
**TYPICAL SMOKE – CO<sub>2</sub> CHART WITH ADJUSTMENT RANGE**

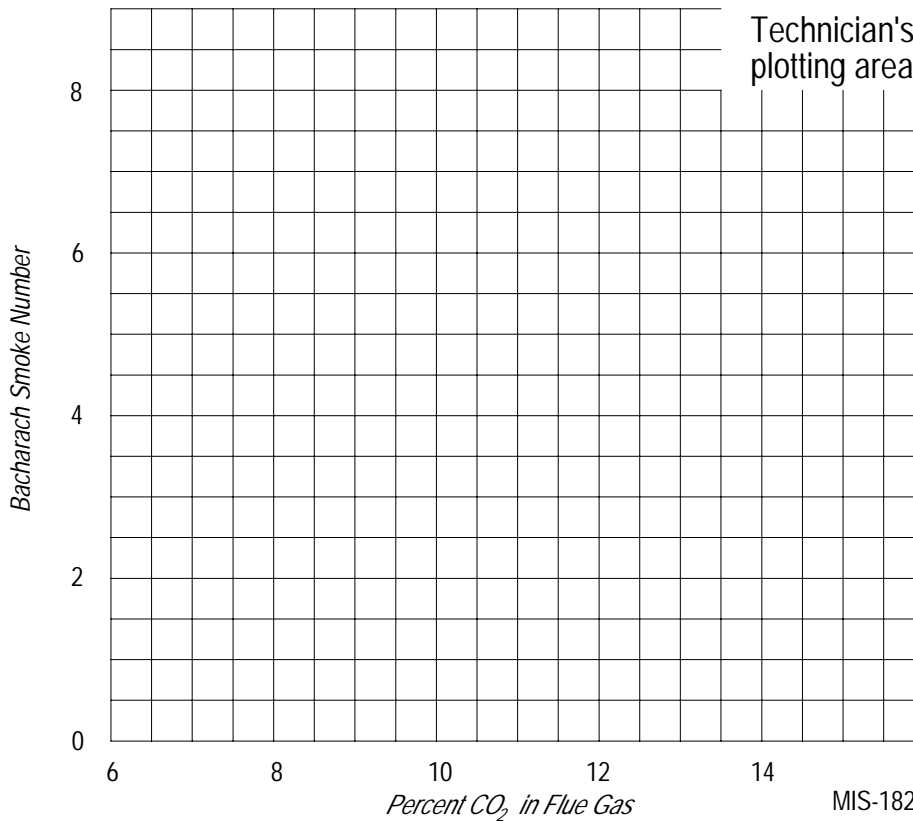
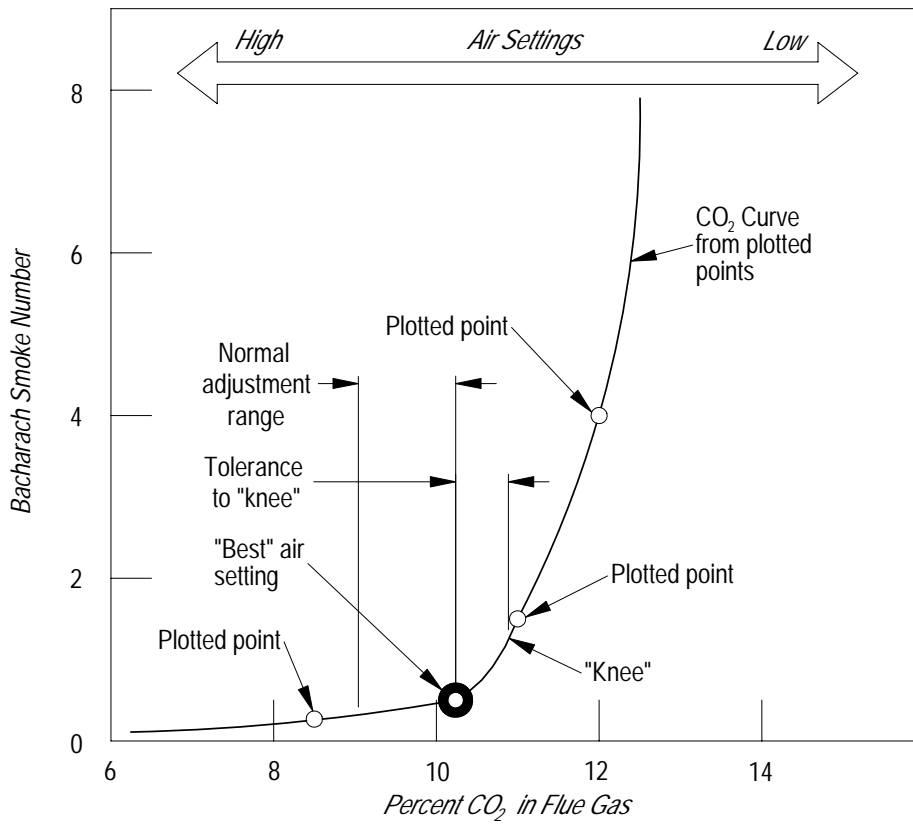

MIS-1827



**FIGURE 9**  
**PRESSURE GAUGE CONNECTION TO BLEED PORT**

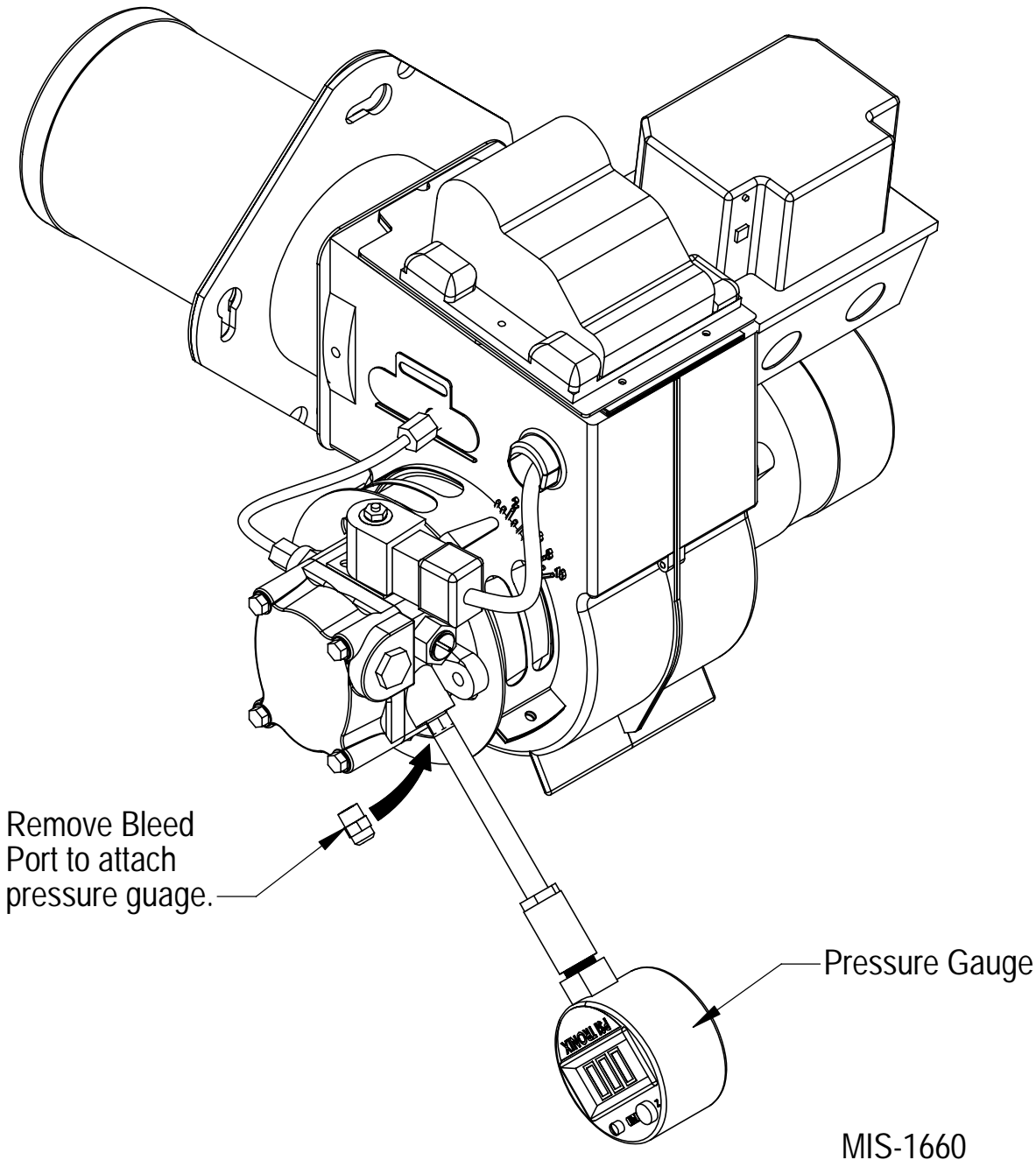

**TABLE 5  
CORRELATION OF PERCENT OF CO<sub>2</sub>, O<sub>2</sub>  
AND RESERVE AIR**

Carbon Dioxide	Oxygen	Reserve Air (Approx.)
15.4	0.0	0.0
15.0	0.6	3.0
14.5	1.2	6.0
14.0	2.0	10.0
13.5	2.6	15.0
13.0	3.3	20.0
12.5	4.0	25.0
12.0	4.6	30.0
11.5	5.3	35.0
11.0	6.0	40.0
10.5	6.7	45.0
10.0	7.4	50.0

**TABLE 6  
NO. 2 FUEL OIL EFFICIENCY CHART  
(NET STACK TEMP. DEGREES F)**

% O <sup>2</sup>	200	250	300	350	400	450	500	550	600	650	700	750	800	% O <sup>2</sup>
1	89.6	88.4	87.3	86.2	85.1	84.0	82.9	81.7	80.6	79.5	78.4	77.3	76.2	14.7
2	89.4	88.2	87.0	85.9	84.7	83.6	82.4	81.2	80.1	78.9	77.7	76.6	75.4	14.0
3	89.2	87.9	86.7	85.5	84.3	83.1	81.9	80.7	79.4	78.2	77.0	75.8	74.6	13.2
4	88.9	87.7	86.4	85.1	83.8	82.6	81.3	80.0	78.7	77.5	76.2	74.9	73.6	12.5
5	88.7	87.3	86.0	84.6	83.3	82.0	80.6	79.3	77.9	76.6	75.3	73.9	72.6	11.7
6	88.4	87.0	85.5	84.1	82.7	81.3	79.9	78.5	77.0	75.6	74.2	72.8	71.4	11.0
7	88.0	86.5	85.0	83.5	82.0	80.5	79.0	77.5	76.0	74.5	73.0	71.5	70.0	10.3

**TABLE 7  
RECOMMENDED START-UP SETTINGS**

Furnace Model No.	Burner Style Part No.	Factory Installed			Field Installed Option					
		① Nozzle	Air Band Setting	Air Shutter Setting	① Nozzle	Air Band Setting	Air Shutter Setting	① Nozzle	Air Band Setting	Air Shutter Setting
FH085D36F	AFG/9020-026	.75	0	6	.65	0	5	.55	0	5
FH110D48E	AFG/9020-027	1.00	2	10	.85	0	8	NA	NA	NA
FH110D60E	AFG/9020-027	1.00	2	10	.85	0	8	NA	NA	NA
FLF085D36F	AFG/9020-026	.75	0	6	.65	0	5	.55	0	5
FLF110D48E FLF110D60E	AFG/9020-027	1.00	2	10	.85	0	8	NA	NA	NA
FLR085D36F	AFG/9020-031	.75	0	6	.65	0	5	.55	0	5
FLR110D48E FLR110D60E	AFG/9020-032	1.00	2	10	.85	0	8	NA	NA	NA
FLR140D60E	AFG/9020-033	1.25	0	8	1.10	0	6	NA	NA	NA
FC085D36F	AFG/9020-026	.75	0	6	.65	0	5	.55	0	5

① 70 degree hollow cone spray pattern, 100 PSIG pump pressure

## SPACING OF ELECTRODES

The electrodes should be spaced  $5/32$ " apart. They should extend  $1/16$ " beyond the end and  $5/16$ " above the center of the nozzle tip as shown in Figure 10.

## GUN ASSEMBLY ADJUSTMENT

The gun assembly can be adjusted in the slot inside of fan housing by loosening screw holding slot cover in position. Nozzle tip should ordinarily be located  $1-1/8$ " behind the front face of the cone.

## REMOVING GUN ASSEMBLY

Disconnect the oil line at the fan housing and remove lock nuts on copper tube fitting. Loosen igniter hold down clamps, then swing igniter up and backward. Gun assembly can now be removed through this opening.

## COMBUSTION AIR REQUIREMENTS

This furnace must be installed in a location where a sufficient supply of combustion air is available for the complete combustion of the fuel oil. Keep in mind that a certain amount of excess air is required as well to ensure complete combustion of the fuel oil.

When structures are constructed too tightly to supply sufficient combustion air, air from outside the structure is required to be brought in directly to the furnace. This furnace has been conveniently designed to accept a combustion air boot which is attached directly to the outdoors by means of a 4" pipe. This pipe can be rigid or flexible, but it is recommended that a metallic material be used. Refer to Figure 11. The air boot used for this design is a Field Controls model number CAS-2B-90E that can be purchased through your local distributor. Follow all installation procedures as specified in the instructions packaged with the air boot kit.

**FIGURE 10  
ELECTRODE ADJUSTMENTS**

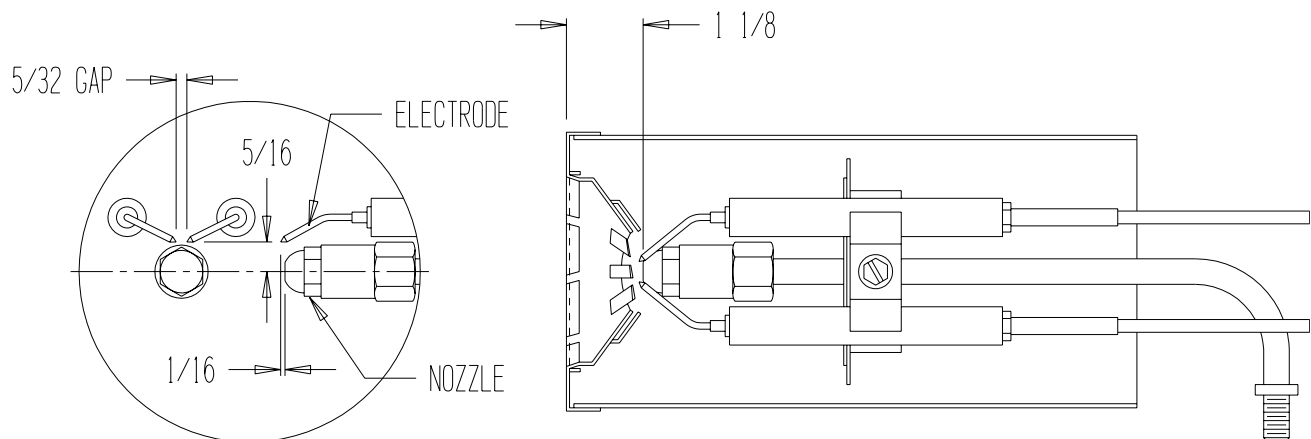

MIS-160

FIGURE 11  
COMBUSTION AIR BOOT ASSEMBLY

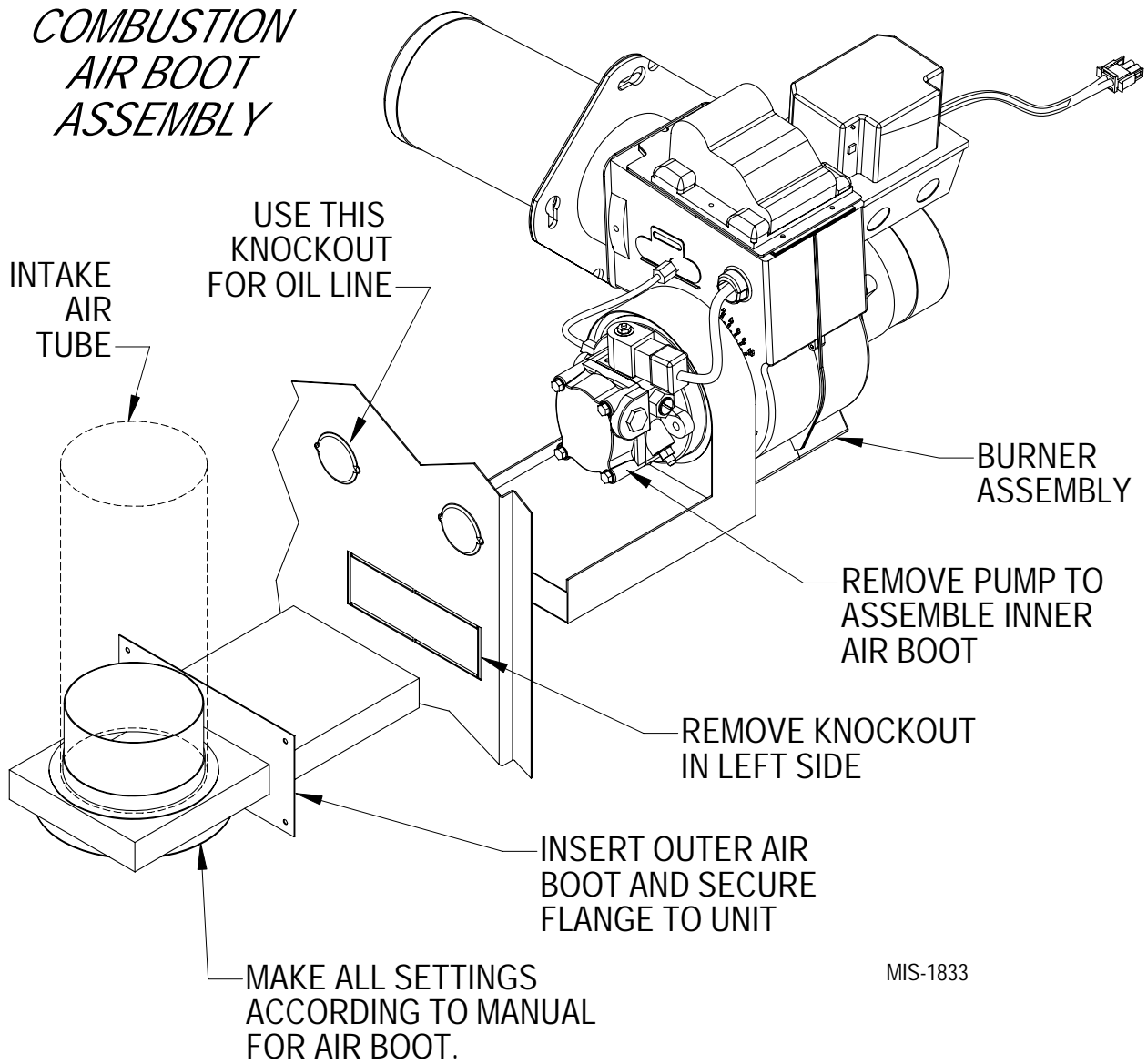

**APPLIANCES LOCATED IN CONFINED SPACES**

In unconfined spaces in buildings, infiltration may be adequate to provide air for combustion, ventilation, and dilution of flue gases. However, in buildings of unusually tight construction, additional air shall be provided using the method described under “All Air From Outdoors” in Figure 13.

An unconfined space (such as an open basement) must have a minimum volume of 50 cubic feet per 1,000 BTUH of total of *all* appliances in area. Adjoining rooms may be counted as one area only if there are not doors between the rooms.

Shown in Table 8 are the required minimum areas in square feet to qualify as an unconfined space for various total BTUH input ratings. The table is based on a room(s) with 8 foot ceiling heights.

If the unconfined space is within a building having insufficient air because of tight construction, the air for combustion and ventilation shall be obtained from outdoors or from spaces freely communicating with the outdoors. Under these conditions a permanent opening or openings have a total free area of not less than one square inch per 5,000 BTU per hour (28 square inches per hour ) of total input rating of all appliances shall be provided. For combustion air options see Page 25, “Combustion Air Requirements”.

**TABLE 8  
SQUARE FEET REQUIRED TO  
QUALIFY AS UNCONFINED SPACE**

Total BTUH Input	Unconfined Space Minimum Area In Square Feet 8' Ceiling Height
60,000 80,000	375 500
85,000 105,000	531 656
115,000 120,000	719 750
140,000 145,000	875 906
160,000 200,000	1000 1250

**FIGURE 12  
APPLIANCES LOCATED  
IN CONFINED SPACES  
ALL AIR FROM INSIDE THE BUILDING**

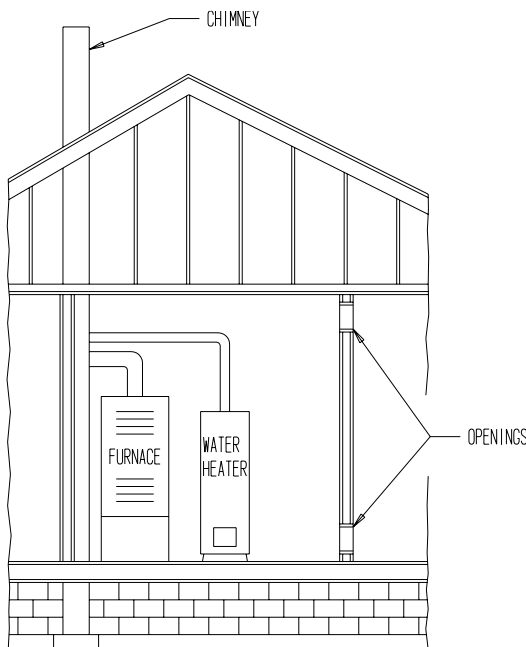

**ALL AIR FROM INSIDE BUILDING**

The confined space shall be provided with two permanent openings, one near the top of the enclosure and one near the bottom. Each opening shall have a free area of not less than one square inch per 1,000 BTU per hour (140 square inches per gallon per hour) of the total input rating of all appliances in the enclosure freely communicating with interior areas having in turn adequate infiltration from the outside. (See Figure 12.) Also see Table 9 on the following page for specific ventilation opening requirements for the furnace only.

***The flow of combustion and ventilating air must not be obstructed from reaching the furnace.***

***NOTE: Each opening shall have a free area of not less than one square inch per 1,000 BTU per hour (140 square inches per gallon per hour) of the total input rating of all appliances in the enclosure.***

**TABLE 9  
MINIMUM VENTILATION OPENINGS**

Model	Min. Ventilation Opening Square Inch	Recommended Opening (2 Required)	
		Size	Sq. In.
FH085D36F	240	8 x 16	128
FH110D48E	280	9 x 18	162
FH110D60E	280	9 x 18	162
FLF085D36F	290	8 x 19	152
FLR085D36F	290	8 x 19	152
FLF110D48E FLF110D60E	340	9 x 19	171
FLR110D48E FLR110D60E	340	9 x 19	171
FLR140D60E	360	9.5 x 19	180
FC085D36F	240	8 x 16	128

**ALL VENTILATION AIR FROM OUTDOORS**

- A. The confined space shall be provided with two permanent openings, one in or near the top of the enclosure and one in or near the bottom. The openings shall communicate directly, or by means of ducts with outdoors or to such spaces (crawl or attic) that freely communicate with outdoors. (See Figures 13, 14, & 15.)
- B. When directly communicating with outdoors or by means of vertical ducts, each opening shall have a free area of not less than one square inch per 4,000 BTU per hour (35 square inches per gallon per hour) of total input rating of all appliances in the enclosures. If horizontal ducts are used, each opening shall have a free area of not less than one square inch per 2,000 BTU per hour (70 square inches per gallon per hour) of total input of all appliances in the enclosure.

**FIGURE 13  
APPLIANCES LOCATED IN CONFINED SPACES  
ALL AIR FROM OUTDOORS**

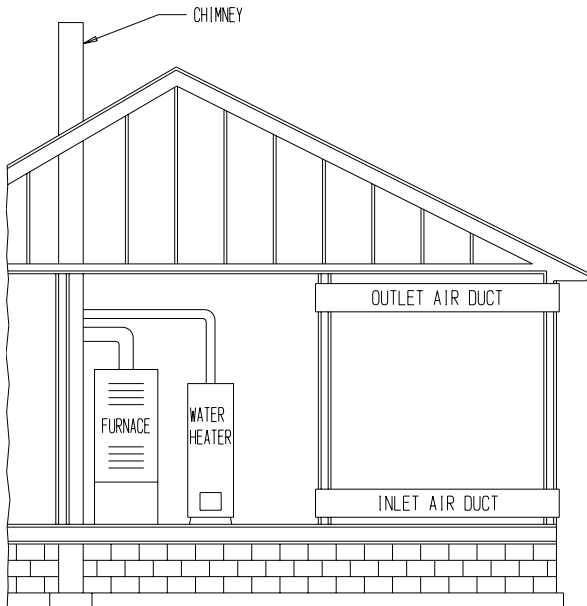

*NOTE: Each air duct opening shall have a free area of not less than one square inch per 2,000 BTU per hour (70 square inches per gallon per hour) of the total input rating of all appliances in the enclosure.*

MIS-1337

**FIGURE 14**  
**APPLIANCES LOCATED IN CONFINED SPACES**  
**ALL AIR FROM OUTDOORS THROUGH VENTILATED ATTIC**

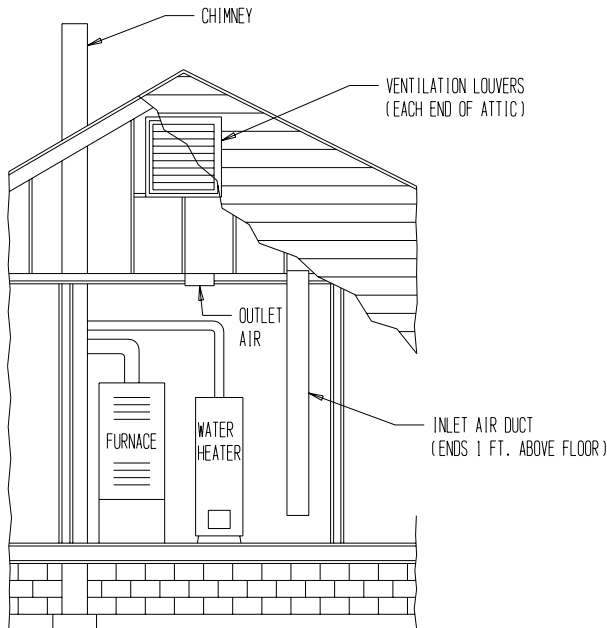

*NOTE: The inlet and outlet air openings shall each have a free area of not less than one square inch per 4,000 BTU per hour (35 square inches per gallon per hour) of the total input rating of all appliances in the enclosure.*

MIS-1338

**FIGURE 15**  
**APPLIANCES LOCATED IN CONFINED SPACES**  
**ALL AIR FROM OUTDOORS**  
**INLET AIR FROM VENTILATED CRAWL SPACE AND OUTLET AIR TO VENTILATED ATTIC**

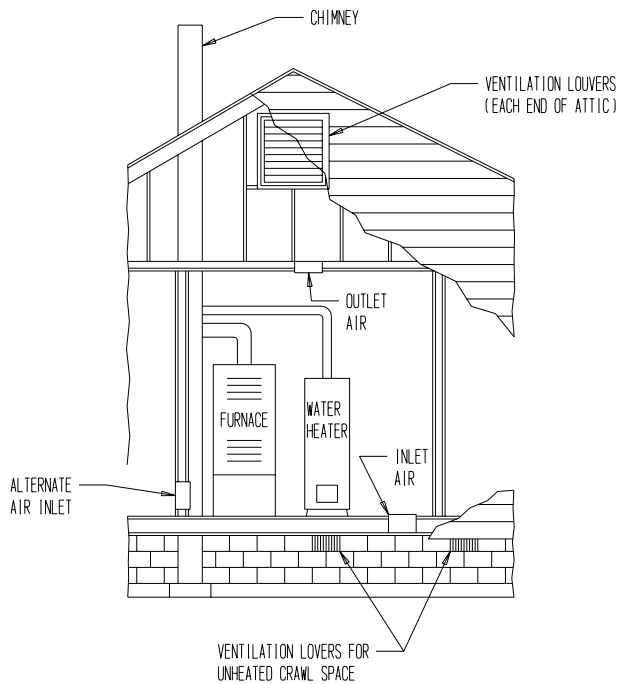

*NOTE: The inlet and outlet air openings shall each have a free area of not less than one square inch per 4,000 BTU per hour (35 square inches per gallon per hour) of the total input rating of appliances in the enclosure.*

MIS-1339



## LOUVERS AND GRILLES

In calculating free area for ventilation and combustion air requirements, consideration shall be given to the blocking effect of louvers, grilles, or screens protecting openings. Screens used shall not be smaller than 1/4 inch (6.3 mm) mesh and shall be readily accessible for cleaning. If the free area through a design of louver or grille is known, it shall be used in calculating the size opening required to provide the free area specified. If the design and free area is not known, it may be assumed that wood louvers will have 30-35 percent free area and metal louvers and grilles will have 60-75 percent free area.

## VENTING OPTIONS

This furnace is designed to be vented conventionally into a vertical chimney or horizontally through a side wall with an optional Field Controls side wall power venting system.

Note that the FH, FC and FLF series furnaces have been designed to allow for bringing the vent system through the cabinet side for increased venting flexibility. To take advantage of this feature, simply remove the desired knockout from either side or top of unit and rotate flue box accordingly by removing four (4) screws under cleanout plate as shown in Figure 4. Make sure smoke pipe gasket is in place before reinstalling flue box screws.

## VERTICAL VENTING

If the unit is to be vertically vented make sure the flue pipe from the furnace to the chimney is the same size diameter as the flue outlet of the furnace which is 6". The flue pipe must have no reductions in diameter, be made of a corrosion-resistant material having an upward pitch of 1/4" for every foot of horizontal run, and be made of material capable of handling temperatures up to 1800° F.

A barometric damper is supplied with the furnace and must be installed in the flue pipe observing the instructions packaged with the damper control. The barometric damper opening must be located in the same atmospheric pressure zone as the combustion air inlet to the furnace. The furnace **must not** be vented into the same chimney with any solid fuel burning appliance such as a wood burner or pellet burner. Masonry chimneys must be lined with a listed system or other approved material that will resist corrosion, softening or cracking from flue gas temperatures up to 1800° F. See Standard for Installation of Oil Burning Equipment NFPA31 latest edition and Standard for Chimneys NFPA211 latest edition for additional information.

## HORIZONTAL VENTING

This furnace is designed to be horizontally vented through a side wall with an optional side wall power vent. The recommended side wall venter is the Field Controls model number SWG-4HDS for 085 and 110 models, and SWG-5S for 140 models only. This venter can be purchased through your local distributor. Follow all installation instructions packaged with the venter system.

## THERMOSTAT

These furnaces are designed to be controlled with any 24V heating or heating/cooling thermostat. The heat/cool thermostats must be designed for independent heat/cool transformer circuits to assure that the 24V transformer built into the oil primary control does not conflict with the main furnace 24V transformer. The heat anticipator should be set at 0.20A. This is a nominal setting. The thermostat circuit should be checked to verify setting.

**TABLE 10  
TEMPERATURE RISE RANGES, LIMIT CONTROL SETTINGS,  
AND HEATING BLOWER SPEEDS**

Model	① Nozzle	Rise Ranges	Maximum Outlet Air Temp.	Heating Blower Speed
FH085D36F	.55	70 - 100	200	Low
	.65	70 - 100	200	Low
	.75	60 - 90	200	Med
FH110D48E	.85	70 - 100	200	Low
	1.00	60 - 90	200	Med Low
FH110D60E	.85	60 - 90	200	Low
	1.00	60 - 90	200	Med Low
FLF085D36F	.55	60 - 90	200	Low
	.65	60 - 90	200	Low
	.75	60 - 90	200	Med
FLF110D48E	.85	60 - 90	200	Med Low
	1.00	60 - 90	200	Med High
FLF110D60E	.85	60 - 90	200	Med Low
	1.00	60 - 90	200	Med High
FLR085D36F	.55	60 - 90	200	Low
	.65	60 - 90	200	Low
	.75	60 - 90	200	Med
FLR110D48E	.85	60 - 90	200	Med Low
	1.00	60 - 90	200	Med High
FLR110D60E	.85	60 - 90	200	Med Low
	1.00	60 - 90	200	Med High
FLR140D60E	1.10	60 - 90	200	Med Low
	1.25	60 - 90	200	Med High
FC085D36F	.55	70 - 100	200	Low
	.65	70 - 100	200	Low
	.75	60 - 90	200	Med

① 70 degree hollow cone spray pattern, 100 PSIG pump pressure

# AIR FILTERS

Only Lo-Boy models are shipped with air filters. Filter kits are available from your local distributor for Upflow and Counterflow models. Knockouts are provided in the sides of the FH series models to facilitate the cutting of the return openings.

The upflow filter kit part numbers are FR23 for a 16x25x1 filter size and FR24 for a 20x25x1 filter size. These filter kits come complete with the filter and all necessary brackets for installing on the furnace. Each comes with a washable aluminum mesh filter. When installing a five ton AC unit on the furnace, one FR24 or Two FR23 must be used due to the high airflow requirements. It is important to note that a minimum of one inch spacing is required between the filter and the unit side. Do not exceed 400 fpm for fiberglass (disposable) type filters and 575 fpm for washable type filters. See Figure 16.

The counterflow filter kit part number FR25 comes with two washable filters. If not installing the FR25 kit remember not to exceed 400 fpm for fiberglass (disposable) type filters and 575 for washable type filters. See Figure 17.

See Table 11 for filter sizes and quantities.

**TABLE 11  
FILTER SIZES FOR OIL FURNACES**

Model	Size
FH085D36F Hi-Boy	(1) 16 x 25 x 1
FH110D48E Hi-Boy	(1) 16 x 25 x 1
FH110D60E Hi-Boy	(1) 20 x 25 x 1
FLF085D36F FLR085D36F Lo-Boys	(1) 16 x 20 x 1
FLF110D48E FLR110D48E FLF110D60E FLR110D60E Lo-Boys	(1) 20 x 20 x 1
FLR140D60E Lo-Boy	(1) 20 x 25 x 1
FC085D36F Counterflow	(2) 16 x 20 x 1

**FIGURE 16  
TYPICAL INSTALLATION OF FR26 AND  
FR27 FILTER RACKS**

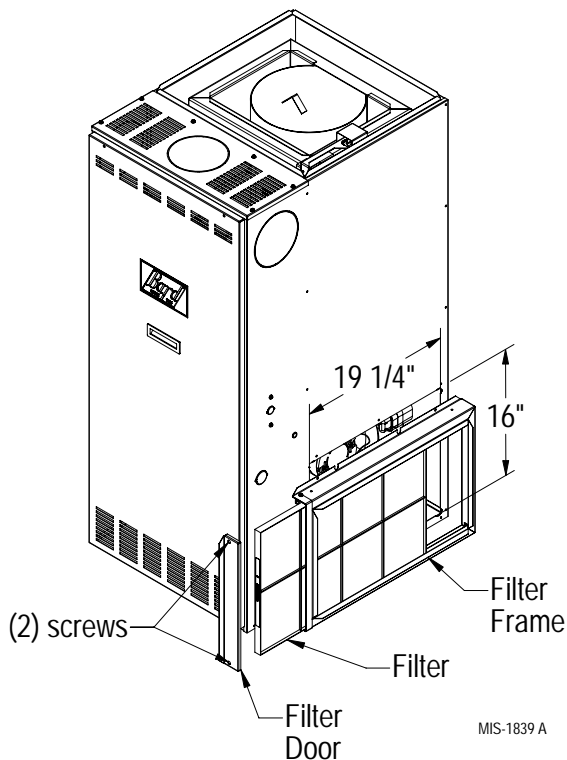

**FIGURE 17  
TYPICAL INSTALLATION OF FR25  
FILTER KIT**

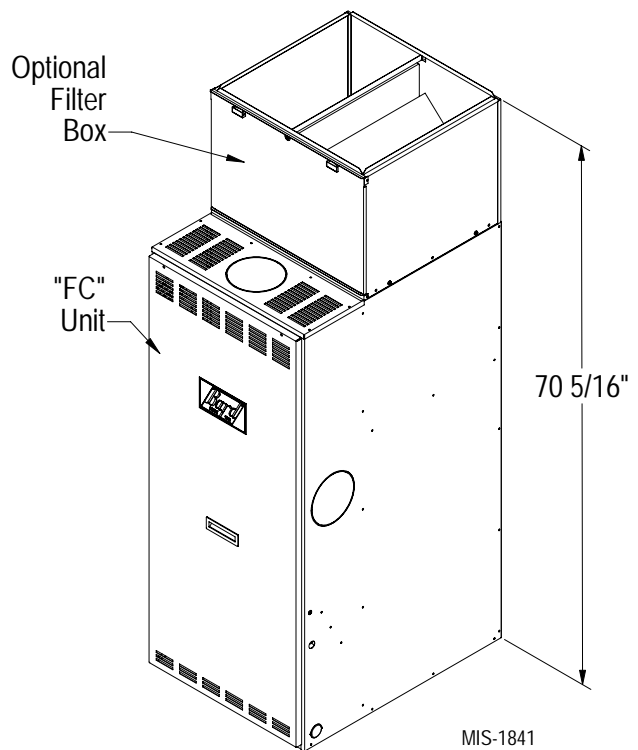

## LO-BOY MODELS – FILTER LOCATIONS

Lo-boy models have the filter installed in the return air cabinet section of the furnace. It is accessible from the rear of the furnace by removing the blower/filter access door. The electrical switch should be turned “off” prior to removing the access door. Refer to Figure 18 below.

**FIGURE 18**  
**FILTER INSTALLATION – LO-BOY MODELS**

UNIT	FILTER SIZE
FLF/FLR085	16 x 20 x1
FLF/FLR110	20 x 20 x1
FLR140	20 x 25 x 1

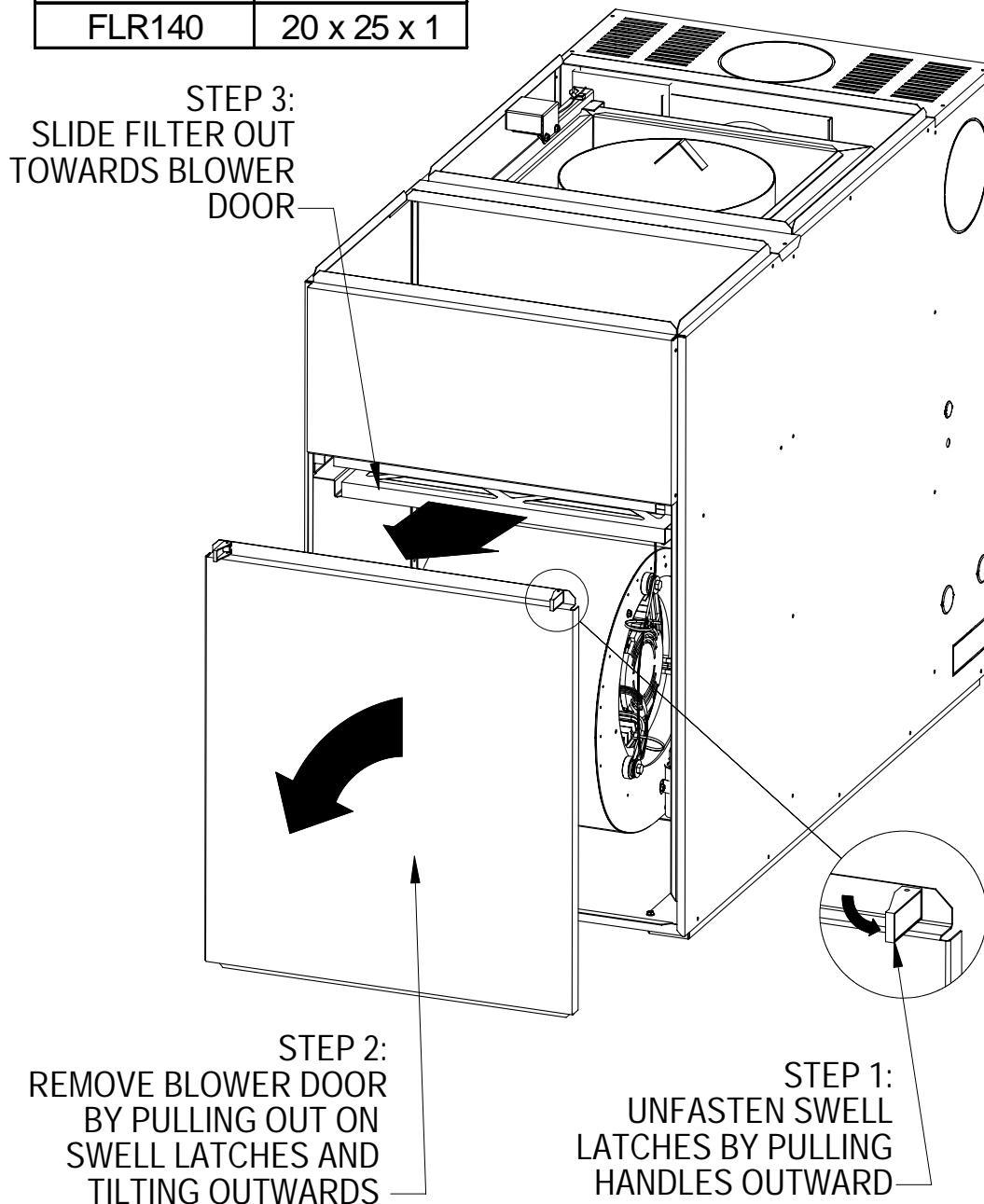

MIS-1835

## LUBRICATION

No lubrication is required for either the burner or the blower motor. Both are permanently lubricated.

## INSPECT AIR FILTER

Replace filters before each heating season begins. It is recommended that filters also be replaced at least twice during the heating season.

Be sure the new filters are set securely in the filter rack so there can be minimal leakage around them.

## FINAL INSPECTION AND TEST

Final inspection and test of an installation shall be made to determine that the work has been done in full accordance with regulations and according to the highest standards for safety, performance and appearance. Such an inspection and test should indicate the following as a minimum:

1. Determine that all parts of the oil storage and circulating system, including tank, piping and burner, are free from oil leaks. Be sure that no oil discharges from the nozzle when burner is not operating.
2. Be sure that the suction line and pump have been entirely vented of air so that the burner has instantaneous oil shutoff at the nozzle and so that the pump operates without an air noise.
3. Check the flame adjustment to determine that the flame is clear, quiet, free of odor and oil nozzle is of proper size for the furnace.
4. Test operation of burner by operating the thermostat. First, set the thermostat above room temperature. Burner should start. Second, set thermostat below room temperature. Burner will stop.
5. Check operation of burner primary control in accordance with manufacturer's instructions included with the control. Following is the method we recommend in checking the safety switch in this primary control.
  - A. Flame Failure – Simulate by shutting off oil supply manual valve while burner is on. Within 9 seconds the control will shut the burner down and flash a diagnostic code of 1/2 second on / 1/2 second off. Ignition and motor stop and oil valve closes

- B. Ignition Failure – Test by closing oil supply while burner is off. Run through starting procedure. The primary control will attempt three trials for ignition. After three attempts, the control will lockout.
- C. Power Failure – Turn off power supply while burner is on. When burner goes out, restore power and burner will restart.
- D. If operation is not as described, check wiring and installation first. If trouble appears to be in the control circuit, replace the flame detector. If trouble still persists, refer to "Common Causes of Trouble" section.

## SERVICE HINTS

Preventive maintenance is the best way to avoid unnecessary expense, inconvenience, and retain operating efficiency of your furnace. It is advisable to have your heating system and burner inspected at periodic intervals by a qualified serviceman. If trouble develops, follow these simple checks before calling the serviceman.

1. Make sure there is oil in tank and valve is open.
2. Make sure thermostat is set above room temperature.
3. Make sure electrical supply to furnace is on and fuses are not blown or circuit breakers tripped.
4. Reset safety switch of burner primary control.



## CAUTION

Reset three (3) times only. More than three resets can cause excessive oil to be pumped into combustion chamber which could result in explosion upon ignition.

5. Make sure air filters are in place and are clean.
6. Make sure all air openings in furnace, all ventilation and combustion air openings, all return air grilles, and all warm air registers are unobstructed and open.

## COMBINATION COMBUSTION CHAMBER/BURNER MOUNTING SYSTEM

The furnace has been designed with a combustion chamber mounting system that enables service personnel to remove the combustion chamber, its mounting system, and burner assembly as one unit for inspection and/or service on the bench. It has also been designed to remove the burner assembly independently from the mounting system to perform basic annual service and inspection. The mounting system is completely adjustable so exact alignment between the burner tube and combustion chamber may be assured prior to installation into the furnace. See Figure 19 and 20.

## WARNING

The procedures described in Figures 19 and 20 should be conducted only by a qualified service technician.

Improper servicing could cause electric shock hazard, fires or explosion resulting in damage, injury or death.

**FIGURE 19  
REMOVAL OF BURNER ONLY**

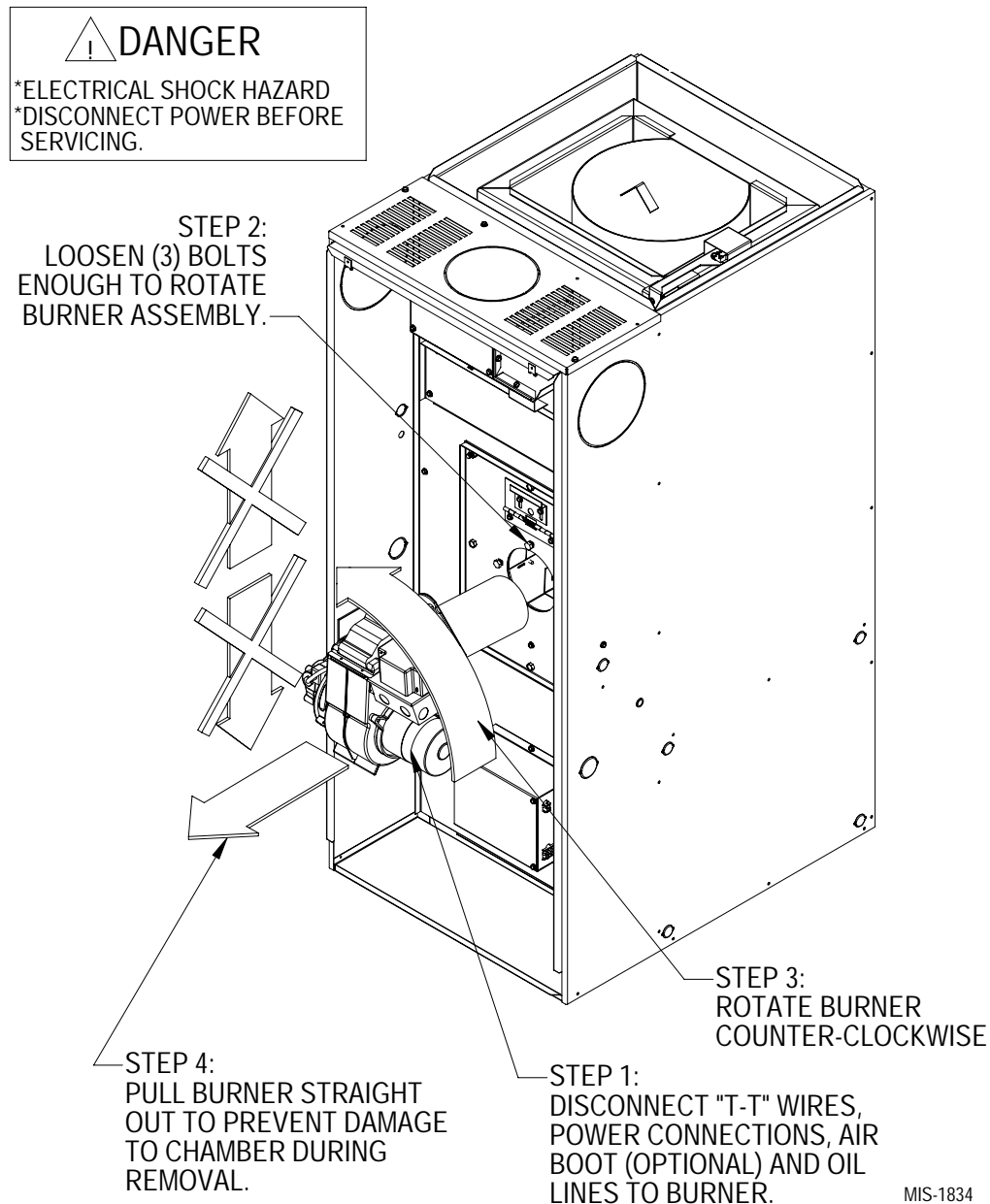

## TO REMOVE BURNER ONLY

Disconnect fuel line, power cord and wires from T, T on primary control. Loosen (3) 1/4 inch bolts securing burner mounting flange. Twist burner counterclockwise and pull straight back away from the furnace. (See Figure 19.)

## TO REMOVE THE ENTIRE COMBUSTION CHAMBER MOUNTING SYSTEM

Disconnect fuel line, power cord and wires from T, T on primary control. Remove (6) 5/16 inch bolts from around front plate. Next remove (2) 5/16 inch nuts from upper right and left hand corners of the front plate. Pull entire assembly straight back away from furnace. **BE CAREFUL NOT TO TIP ASSEMBLY UP OR DOWN AS IT MAY DAMAGE THE COMBUSTION CHAMBER.** (See Figure 20.)

**FIGURE 20**  
**REMOVAL OF ENTIRE COMBUSTION CHAMBER MOUNTING SYSTEM**

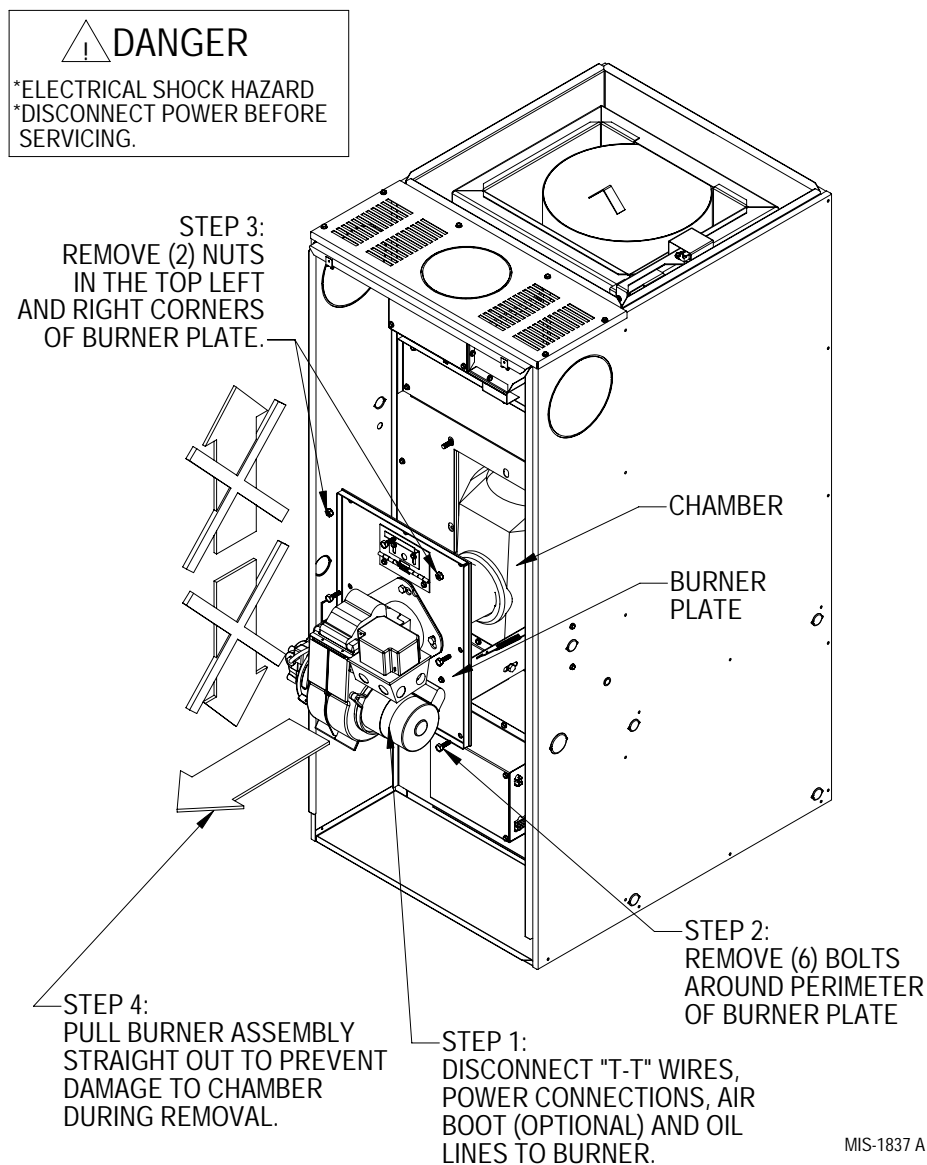



## COMMON CAUSES OF TROUBLE

### CAUTION

To avoid accidents, always open main switch (OFF position) when servicing the burner.

#### BURNER WILL NOT PRODUCE FLAME

Check oil level gauge to see that there is sufficient oil in tank or tanks. Check the burner mounted relay control. *Do not adjust this control.*

Check position of electrodes – incorrect position will cause slow or delayed ignition. Clean electrodes and nozzle. Check and clean strainer in pump. If oil line filter is used, check filter condition.

If burner runs but there is no flame the fuel pump may be air bound. Follow instructions for bleeding fuel pump.

Check and make sure the solenoid valve on the oil pump is being energized and opening.

#### BURNER STARTS OR STOPS TOO OFTEN

Check heat anticipator setting on thermostat.

#### NOZZLE PRODUCES A STRINGY FLAME

Worn tangential grooves in nozzle. Replace nozzle.

#### BASEMENT TANK HUM

Occasionally with a two-pipe installation there may be a low return line hum. Eliminate hum by installing a special anti-hum valve in the return line near pump.

#### HEAVY FIRE OR PULSATING FLAME.

These may occur after burner starts. It may be caused by a slight oil leak in the fuel pump and cannot be corrected except by replacing the pump. This happens only when the burner is started.

#### CHATTERING SOUND OR HIGH PITCH NOISE

This noise from motor can usually be traced to where a conduit or BX cable is fixed rigidly or attached to some part of the building. Relieving this strain may eliminate noise.

## PUMP SQUEALS OR CHATTERS

This may be caused by air in pipes. Check all joints in the oil supply pipe for leaks. Check strainer in pump; if dirty, clean.

#### INSUFFICIENT HEAT

Check limit control setting. It may be that flame is not allowed to stay on long enough to generate sufficient heat in furnace to heat the house properly. If the proper size furnace has been selected according to house requirements and satisfactory heat is not obtained, recheck the heating plant for size and capacity in relation to house. Check for clogged filters.

Check and make sure the heat anticipator on the thermostat is set correctly.

#### CARE OF FINISH

This furnace cabinet is made with a very durable and corrosion resistant finish. With normal cleaning it will last for many years.

### WARNING

Under **no** circumstance should a soot deterioration device be used in the combustion chamber. These products known as “soot busters” or “soot sticks” are comprised of chemicals that burn at very high temperatures, which may exceed the temperature rating of the combustion chamber material.

Use of these products are detrimental to the life expectancy of the combustion chamber and will destroy the chamber. Refer to the “Cleaning of Furnace” section for proper cleaning methods.

## CLEANING OF THE HEAT EXCHANGER

All of these units have four clean out plugs for easy cleaning of the heat exchanger. They are accessible from the front and back of these units by removing the clean out access cover in the burner compartment and at the back of unit. The furnace should be checked annually by a qualified service technician.

# BLOWER SYSTEM RESISTANCE CHARTS

---

**CHART 1  
FH085D36F DATA**

Blower Speed	Blower Static			
Low	.10	.15	.23	.30
Medium	.16	.24	.34	.43
High	.20	.30	.40	.50

**CHART 4  
FLF/FLR085D36F DATA**

Blower Speed	Blower Static			
Low	.07	.13	.19	.25
Medium	.15	.24	.33	.41
High	.20	.30	.40	.50

**CHART 2  
FH110D48E DATA**

Blower Speed	Blower Static			
Low	.03	.08	.13	.18
Medium Low	.09	.16	.23	.32
Medium High	.16	.25	.34	.44
High	.20	.30	.40	.50

**CHART 5  
FLF/FLR110D48E DATA**

Blower Speed	Blower Static			
Low	.05	.09	.15	.20
Medium Low	.09	.16	.23	.31
Medium High	.15	.24	.34	.42
High	.20	.30	.40	.50

**CHART 3  
FH110D60E DATA**

Blower Speed	Blower Static			
Low	.06	.12	.17	.21
Medium Low	.10	.17	.23	.30
Medium High	.14	.21	.31	.38
High	.20	.30	.40	.50

**CHART 6  
FLF/FLR110D60E DATA**

Blower Speed	Blower Static			
Low	.08	.12	.17	.21
Medium Low	.10	.16	.22	.28
Medium High	.13	.21	.29	.36
High	.20	.30	.40	.50

**CHART 7  
FLR140D60E DATA**

<b>Blower Speed</b>	<b>Blower Static</b>			
<b>Low</b>	.05	.14	.17	.24
<b>Medium Low</b>	.08	.17	.22	.30
<b>Medium High</b>	.11	.20	.27	.35
<b>High</b>	.20	.30	.40	.50

**CHART 8  
FC085D36F DATA**

<b>Blower Speed</b>	<b>Blower Static</b>			
<b>Low</b>	.08	.14	.20	.26
<b>Medium</b>	.16	.24	.36	.42
<b>High</b>	.20	.30	.40	.50



# FLF/R SERIES WIRING DIAGRAM

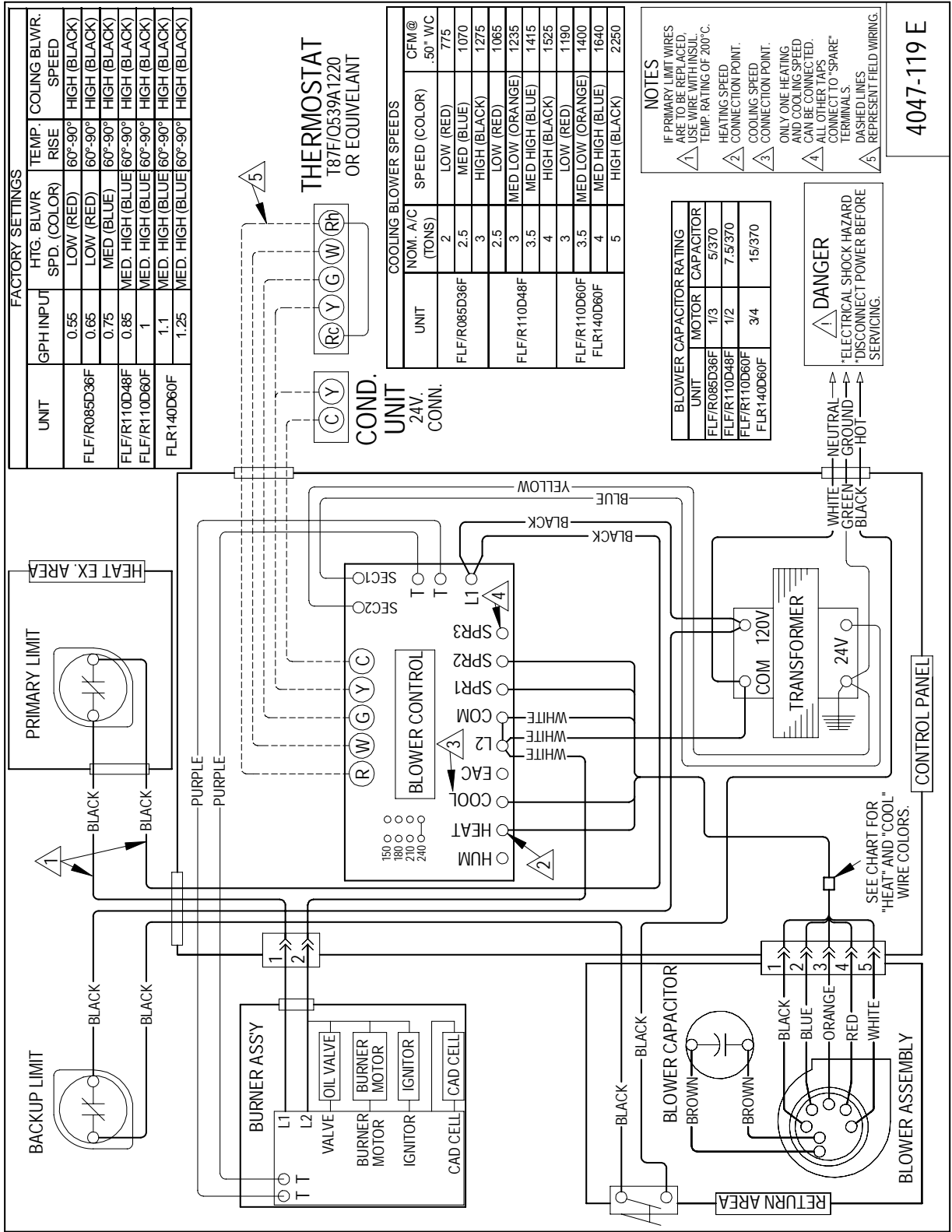

4047-119 E

