

INSTALLATION INSTRUCTIONS

WALL MOUNTED PACKAGED AIR CONDITIONER

Model: **WL701-B, WL701-C, WL702-A, WL721-B**

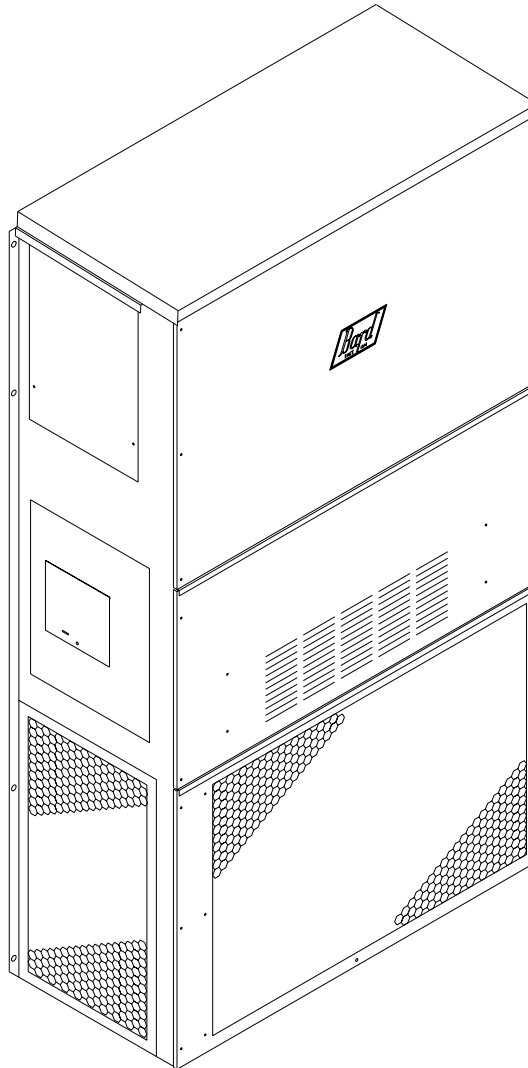

MIS-861



Climate Control Solutions

Bard Manufacturing Company, Inc.
Bryan, Ohio 43506
Since 1914...Moving ahead just as planned.

Manual No.: 2100-426B
Supersedes: 2100-426A
File: Volume III, Tab 16
Date: 10-19-06

CONTENTS

Getting Other Information and Publications

For more information, contact these publishers: 3

Wall Mount General Information

Air Conditioner Wall Mount Model Nomenclature	4
Shipping Damage	6
General	6
Duct Work	6
Filters	7
Fresh Air Intake	7
Condensate Drain	7

Installation Instructions

Wall Mounting Information	8
Mounting the Unit	8
Typical Installations	8
Wiring – Main Power	8 & 9
Wiring – Low Voltage Wiring	9

Figures

Figure 1 Unit Dimensions	5
Figure 2 Blower Damper Assembly	7
Figure 3 Mounting Instructions	9
Figure 4 Electric Heat Clearances	10
Figure 5 Wall-Mounting Instructions	11
Figure 6 Wall-Mounting Instructions	11
Figure 7 Common Wall-Mounting Instructions ...	12
Figure 8 Low Voltage Wiring	13
Figure 9 Start-Up Label	14
Figure 10 Fan Blade Setting	17

Start Up

Important Installer Note	14
Crankcase Heaters	14
High Pressure Switch	14
Three Phase Scroll Compressor Start Up Information	14
Service Hints	15
Sequence of Operation	15
Compressor Control Module	15
Adjustments	16
Phase Monitor	16
Pressure Service Ports	16

Troubleshooting

Fan Blade Setting Dimensions	17
Removal of Fan Shroud	17
Refrigerant Charge	17
Pressure Chart	18
Optional Accessories	18

Tables

Table 1 Electrical Specifications	4
Table 2 Dimensions of Basic Unit	5
Table 3 Electric Heat Table	5
Table 4 Operating Voltage Range	9
Table 5 Thermostat Wire Size	10
Table 6 Wall Thermostat	10
Table 7 Fan Blade Dimensions	17
Table 8 Suction Line Temperatures	17
Table 9 Indoor Blower Performance	17
Table 10 CFM and ESP	17
Table 11 Maximum ESP of Operation Electric Heat Only	17
Table 12 Cooling Pressure	18
Table 13 Optional Accessories	18

Getting Other Information and Publications

These publications can help you install the air conditioner or heat pump. You can usually find these at your local library or purchase them directly from the publisher. Be sure to consult current edition of each standard.

National Electrical Code ANSI/NFPA 70

Standard for the Installation ANSI/NFPA 90A
of Air Conditioning and Ventilating Systems

Standard for Warm Air ANSI/NFPA 90B
Heating and Air Conditioning Systems

Load Calculation for ACCA Manual J or
Residential Winter and Manual N
Summer Air Conditioning

Low Pressure, Low Velocity Duct.. ACCA Manual D or
System Design for Winter and Manual Q
Summer Air Conditioning

FOR MORE INFORMATION, CONTACT THESE PUBLISHERS:

ACCA **Air Conditioning Contractors of America**
1712 New Hampshire Ave. N.W.
Washington, DC 20009
Telephone: (202) 483-9370
Fax: (202) 234-4721

ANSI **American National Standards Institute**
11 West Street, 13th Floor
New York, NY 10036
Telephone: (212) 642-4900
Fax: (212) 302-1286

ASHRAE **American Society of Heating Refrigerating,
and Air Conditioning Engineers, Inc.**
1791 Tullie Circle, N.E.
Atlanta, GA 30329-2305
Telephone: (404) 636-8400
Fax: (404) 321-5478

NFPA **National Fire Protection Association**
Batterymarch Park
P.O. Box 9101
Quincy, MA 02269-9901
Telephone: (800) 344-3555
Fax: (617) 984-7057

WALL MOUNT GENERAL INFORMATION

AIR CONDITIONER WALL MOUNT MODEL NOMENCLATURE

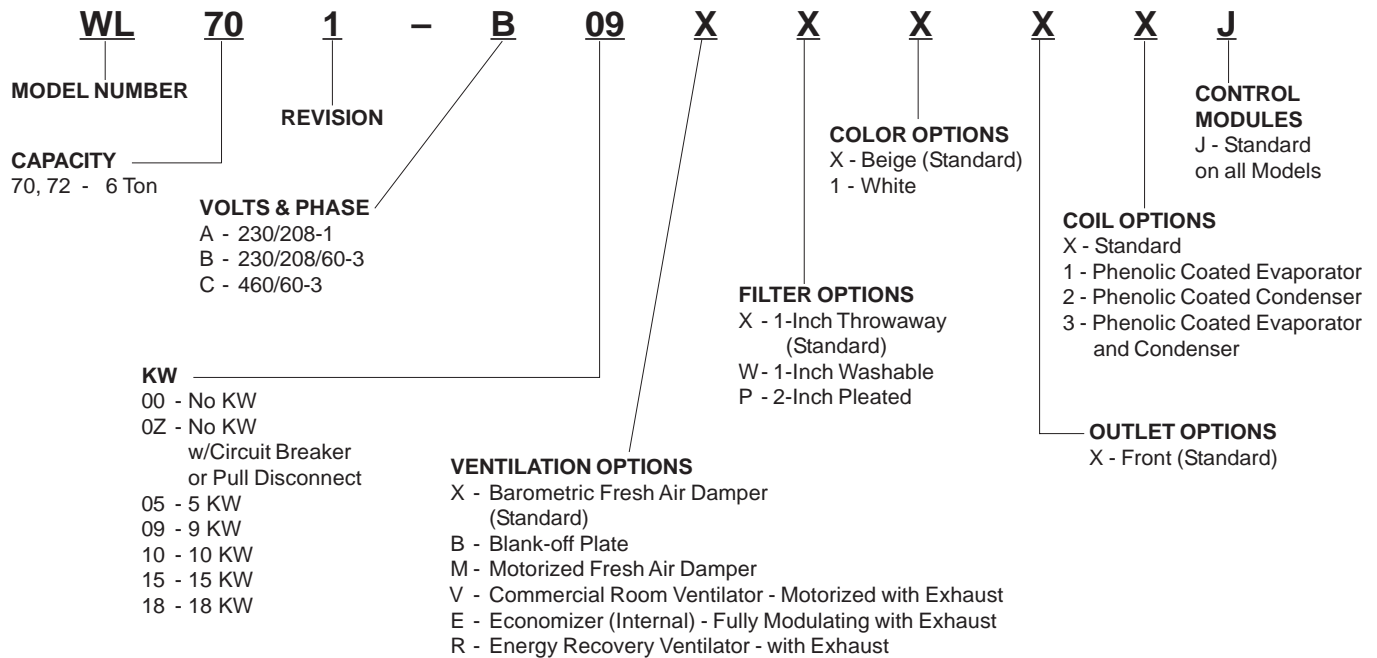

NOTE: For 0 KW and circuit breakers (230/208 V) or pull disconnects (460 V) applications, insert 0Z in the KW field of model number.

**TABLE 1
ELECTRICAL SPECIFICATIONS**

Models	Rated	No. of Power Circuits	Single Circuit				Dual Circuit								
			③ MCA	① MOP	② Field Wire Size	② Ground Wire Size	③ MCA		① MOP		② Field Wire Size		② Ground Wire Size		
							CKT A	CKT B	CKT A	CKT B	CKT A	CKT B	CKT A	CKT B	
															CKT A
WL702-A00,A0Z	203/208-1	1	48	60	8	10	NA	NA	NA	NA	NA	NA	NA	NA	NA
-A05	230/208-1	1	48	60	8	10	NA	NA	NA	NA	NA	NA	NA	NA	NA
-A10	230/208-1	1	59	60	6	10	NA	NA	NA	NA	NA	NA	NA	NA	NA
-A15	230/208-1	1 or 2	85	90	4	8	59	26	60	30	6	10	10	10	10
WL701-B00,B0Z	230/208-3	1	36	50	8	10	NA	NA	NA	NA	NA	NA	NA	NA	NA
-B09		1	36	50	8	10	NA	NA	NA	NA	NA	NA	NA	NA	
-B15		1	52	60	6	10	NA	NA	NA	NA	NA	NA	NA	NA	
WL721-B00,B0Z	230/208-3	1	36	50	8	10	NA	NA	NA	NA	NA	NA	NA	NA	NA
-B09		1	36	50	8	10	NA	NA	NA	NA	NA	NA	NA	NA	
-B15		1	52	60	6	10	NA	NA	NA	NA	NA	NA	NA	NA	
WL701-C00,C0Z	460-3	1	17	25	12	12	NA	NA	NA	NA	NA	NA	NA	NA	NA
-C09		1	17	25	12	12	NA	NA	NA	NA	NA	NA	NA	NA	
-C15		1	26	30	10	10	NA	NA	NA	NA	NA	NA	NA	NA	

- ① Maximum size of the time delay fuse or HACR type circuit breaker for protection of field wiring conductors.
- ② Based on 75°C copper wire. All wiring must conform to the National Electric Code (NEC) and all local codes.
- ③ These "Minimum Circuit Ampacity" values are to be used for sizing the field power conductors. Refer to the National Electric Code (latest version), Article 310 for power conductor sizing.

CAUTION: When more than one filed power conductor circuit is run through one conduit, the conductors must be derated. Pay special attention to Note * of Table 310 regarding Ampacity Adjustment Factors when more than 3 conductors are in a raceway.

**TABLE 2
DIMENSION OF BASIC UNIT FOR ARCHITECTURAL AND
INSTALLATION REQUIREMENTS (NOMINAL)**

Unit	Width W	Depth D	Height H	Supply		Return		E	F	G	I	J	K	L	M	N	O	P	Q
				A	B	C	B												
WL70,72	42	22-1/4	94-7/8	9-7/8	29-7/8	15-7/8	29-7/8	43-7/8	19	41-5/8	30	42-11/16	37	44-3/4	42-1/2	3-1/4	43	33-7/8	10

All dimensions in inches.

**FIGURE 1
UNIT DIMENSIONS**

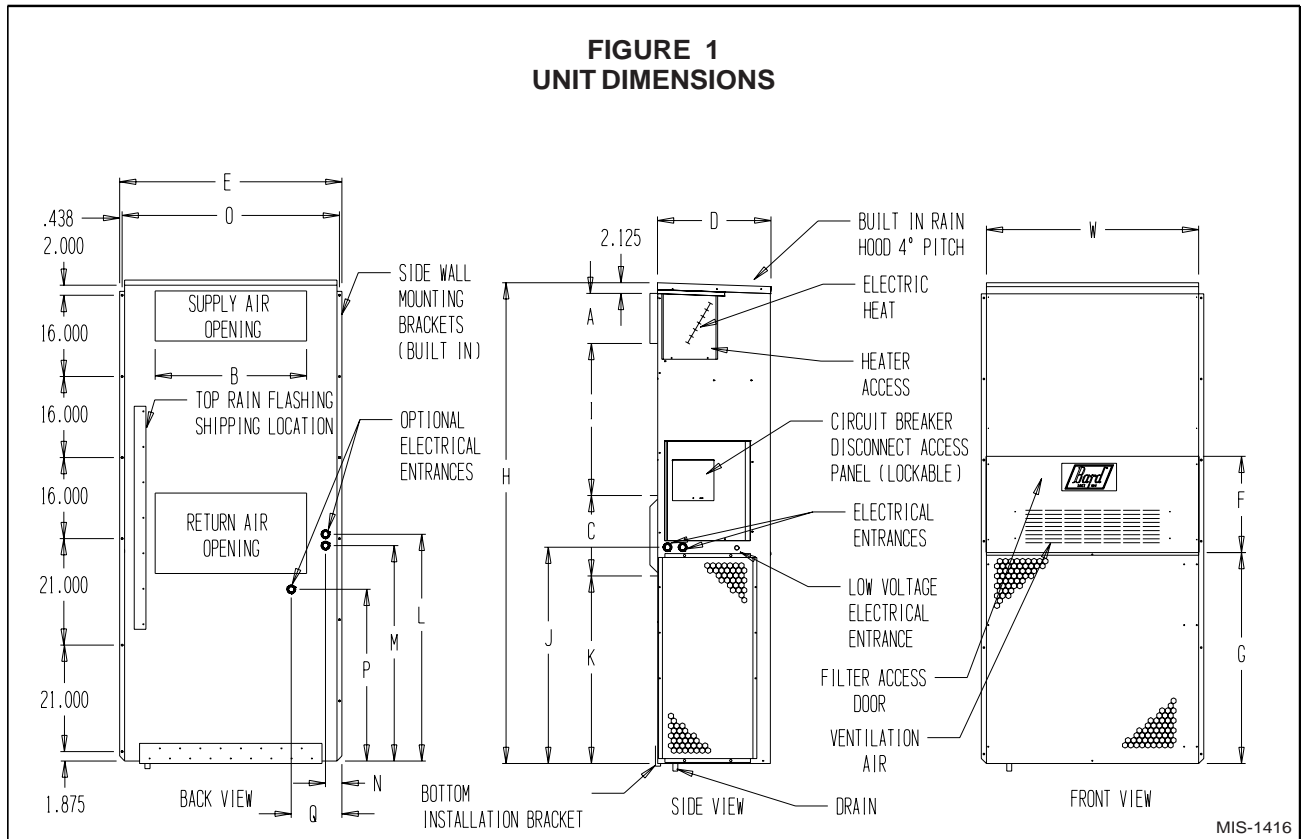

**TABLE 3
ELECTRIC HEAT TABLE**

Models	WL702-A				WL701-B, WL721-B				WL701-C	
	240V-1		208V-1		240V-3		208V-3		460V-3	
	KW	AMPS	BTUH	AMPS	BTUH	AMPS	BTUH	AMPS	BTUH	AMPS
5.0	20.8	17,050	18.1	12,800	---	---	---	---	---	---
9.0	---	---	---	---	21.7	30,600	18.7	23,030	10.8	30,700
10.0	41.6	34,130	36.2	25,600	---	---	---	---	---	---
15.0	62.5	51,200	54.1	38,400	36.2	51,200	31.2	38,400	17.3	47,000

SHIPPING DAMAGE

Upon receipt of equipment, the carton should be checked for external signs of shipping damage. If damage is found, the receiving party must contact the last carrier immediately, preferably in writing, requesting inspection by the carrier's agent.

GENERAL

The equipment covered in this manual is to be installed by trained, experienced service and installation technicians.

The refrigerant system is completely assembled and charged. All internal wiring is complete.

The unit is designed for use with or without duct work. Flanges are provided for attaching the supply and return ducts.

These instructions explain the recommended method to install the air cooled self-contained unit and the electrical wiring connections to the unit.

These instructions and any instructions packaged with any separate equipment required to make up the entire air conditioning system should be carefully read before beginning the installation. Note particularly "Starting Procedure" and any tags and/or labels attached to the equipment.

While these instructions are intended as a general recommended guide, they do not supersede any national and/or local codes in any way. Authorities having jurisdiction should be consulted before the installation is made. See Page 3 for information on codes and standards.

Size of unit for a proposed installation should be based on heat loss calculation made according to methods of Air Conditioning Contractors of America (ACCA). The air duct should be installed in accordance with the Standards of the National Fire Protection Association for the Installation of Air Conditioning and Ventilating Systems of Other Than Residence Type, NFPA No. 90A, and Residence Type Warm Air Heating and Air Conditioning Systems, NFPA No. 90B. Where local regulations are at a variance with instructions, installer should adhere to local codes.

DUCT WORK

All duct work, supply and return, must be properly sized for the design airflow requirement of the equipment. Air Conditioning Contractors of America (ACCA) is an excellent guide to proper sizing. All duct work or portions thereof not in the conditioned space should be properly insulated in order to both conserve energy and prevent condensation or moisture damage.

Refer to Table 11 for maximum static pressure available for duct design.

Design the duct work according to methods given by the Air Conditioning Contractors of America (ACCA). When duct runs through unheated spaces, it should be insulated with a minimum of 1 inch of insulation. Use insulation with a vapor barrier on the outside of the insulation. Flexible joints should be used to connect the duct work to the equipment in order to keep the noise transmission to a minimum.

A 1/4 inch clearance to combustible material for the first three feet of duct attached to the outlet air frame is required. See Wall Mounting Instructions and Figures 3, 5 & 6 for further details.

Ducts through the walls must be insulated and all joints taped or sealed to prevent air or moisture entering the wall cavity.



CAUTION

Some installations may not require any return air duct. A metallic return air grille is required with installations not requiring a return air duct. The spacing between louvers on the grille shall not be larger than 5/8 inches.

Any grille that meets the 5/8 inch louver criteria, may be used. It is recommended that Bard Return Air Grille Kit RG-2 through RG-5 or RFG-2 through RFG-5 be installed when no return duct is used. Contact distributor or factory for ordering information. If using a return air filter grille, filters must be of sufficient size to allow a maximum velocity of 400 fpm.

NOTE: If no return air duct is used, applicable installation codes may limit this cabinet to installation only in a single story structure.

FILTERS

A 1-inch throwaway filter is supplied with each unit. The filter slides into position making it easy to service. This filter can be serviced from the outside by removing the service door. A 1-inch washable filter and 2-inch pleated filter are also available as optional accessories. The internal filter brackets are adjustable to accommodate the 2-inch filter by bending down the tabs to allow spacing for the 2-inch filters.

FRESH AIR INTAKE

All units are built with fresh air inlet slots punched in the service panel.

If the unit is equipped with the fresh air damper assembly, the assembly is shipped already attached to the unit. The damper blade is locked in the closed position to allow the damper to operate, the maximum and minimum blade position stops must be installed. See Figure 2.

All capacity, efficiency and cost of operation information as required for Department of Energy "Energyguide" Fact Sheets is based upon the fresh air blank-off plate in place and is recommended for maximum energy efficiency.

The blank-off plate is available upon request from the factory and is installed in place of the fresh air damper shipped with each unit.

CONDENSATE DRAIN

A plastic drain hose extends from the drain pan at the top of the unit down to the unit base. There are openings in the unit base for the drain hose to pass through. In the event the drain hose is connected to a drain system of some type, it must be an open or vented type system to assure proper drainage.

**FIGURE 2
BLOWER DAMPER ASSEMBLY**

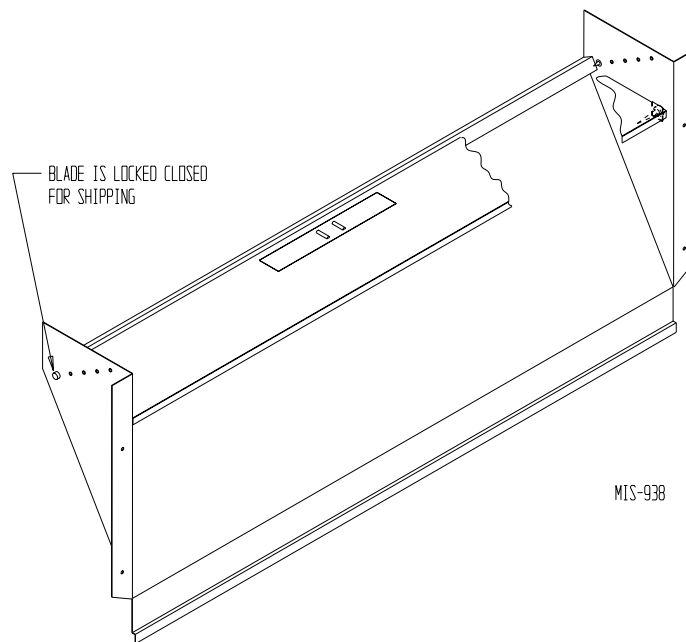

INSTALLATION INSTRUCTIONS

WALL MOUNTING INFORMATION

1. Two holes, for the supply and return air openings, must be cut through the wall as shown in Figure 3.
2. On wood-frame walls, the wall construction must be strong and rigid enough to carry the weight of the unit without transmitting any unit vibration. See Figures 5 and 6.
3. Concrete block walls must be thoroughly inspected to insure that they are capable of carrying the weight of the installing unit. See Figure 5.



WARNING

Fire hazard can result if 1/4 inch clearance to combustible materials for supply air duct is not maintained. See Figure 3.

MOUNTING THE UNIT

1. These units are secured by wall mounting brackets, which secure the unit to the outside wall surface at both sides. A bottom mounting bracket is provided for ease of installation.
2. The unit itself is suitable for “0” inch clearance, but the supply air duct flange and the first 3 feet of supply air duct require a minimum of 1/4 inch clearance to combustible material. If a combustible wall, use a minimum of 30½" x 10½" dimensions for sizing. However, it is generally recommended that a 1-inch clearance is used for ease of installation and maintaining the required clearance to combustible material. The supply air opening would then be 32" x 12". See Figures 3, 4 and 5 for details.



WARNING

Failure to provide the 1/4 inch clearance between the supply duct and a combustible surface for the first 3 feet of duct can result in fire.

3. Locate and mark lag bolt locations and bottom mounting bracket location. See Figure 5.
4. Mount bottom mounting bracket.
5. Hook top rain flashing under back bend of top. Top rain flashing is shipped secured to the right side of the back.

6. Position unit in opening and secure with 5/16 lag bolts; use 7/8 inch diameter flat washers on the lag bolts.
7. Secure rain flashing to wall and caulk across entire length of top. See Figure 3.
8. For additional mounting rigidity, the return air and supply air frames or collars can be drilled and screwed or welded to the structural wall itself (depending upon wall construction). Be sure to observe required clearance if combustible wall.
9. On side-by-side installations, maintain a minimum of 20 inches clearance on left side to allow access to heat strips and control panel and to allow proper airflow to the outdoor coil. Additional clearance may be required to meet local or national codes.

TYPICAL INSTALLATIONS

See Figure 7 for common ways to install the wall-mount unit.

WIRING — MAIN POWER

Refer to the unit rating plate for wire sizing information and maximum fuse or “HACR” type circuit breaker size. Each outdoor unit is marked with a “Minimum Circuit Ampacity”. This means that the field wiring used must be sized to carry that amount of current. Depending on the installed KW of electric heat, there may be two field power circuits required. If this is the case, the unit serial plate will so indicate. All models are suitable only for connection with copper wire. Each unit and/or wiring diagram will be marked “Use Copper Conductors Only”. These instructions **must be** adhered to. Refer to the National Electrical Code (NEC) for complete current carrying capacity data on the various insulation grades of wiring material. All wiring must conform to NEC and all local codes.

The electrical data lists fuse and wire sizes (75°C copper) for all models, including the most commonly used heater sizes. Also shown are the number of field power circuits required for the various models with heaters.

The unit rating plate lists a “Maximum Time Delay Relay Fuse” or “HACR” type circuit breaker that is to be used with the equipment. The correct size must be used for proper circuit protection and also to assure that there will be no nuisance tripping due to the momentary high starting current of the compressor motor.

The disconnect access door on this unit may be locked to prevent unauthorized access to the disconnect. To convert for the locking capability, bend the tab located in the bottom left hand corner of the disconnect opening under the disconnect access panel straight out. This tab will now line up with the slot in the door. When shut, a padlock may be placed through the hole in the tab preventing entry.

See Start-up section for information on three phase scroll compressor start-ups.

WIRING — LOW VOLTAGE WIRING

230/208V, 1 phase and 3 phase equipment dual primary voltage transformers. All equipment leaves the factory wired on 240V tap. For 208V operation, reconnect from 240V to 208V tap. The acceptable operating voltage range for the 240 and 208V taps are:

**TABLE 4
OPERATING VOLTAGE RANGE**

TAP	RANGE
240V	253 - 216
208V	220 - 187

NOTE: The voltage should be measured at the field power connection point in the unit and while the unit is operating at full load (maximum amperage operating condition).

Five (5) wires should be run from thermostat subbase to the 24V terminal board in the unit. A five conductor, 18 gauge copper, color-coded thermostat cable is recommended. The connection points are shown in Figure 8.

**FIGURE 3
MOUNTING INSTRUCTIONS**

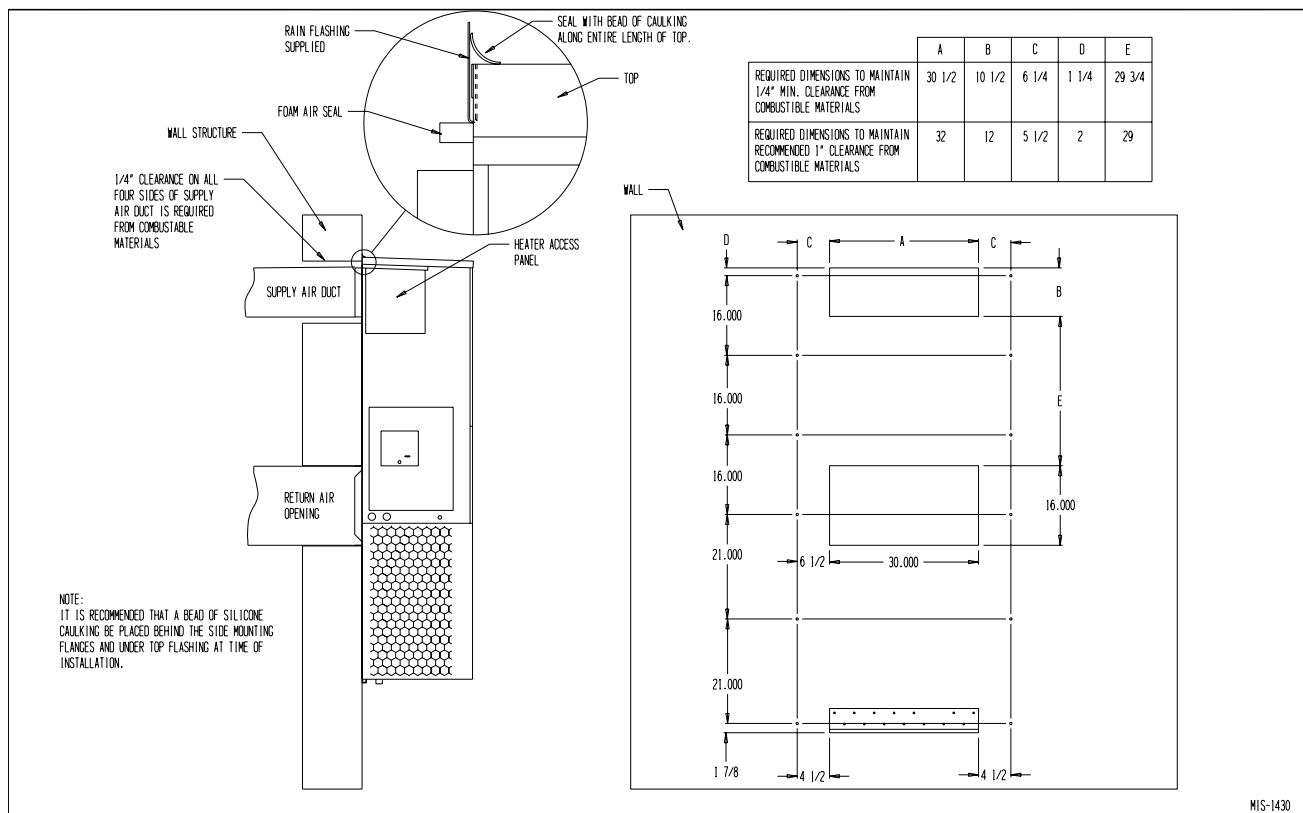

**TABLE 5
THERMOSTAT WIRE SIZE**

Transformer VA	FLA	Wire Gauge	Maximum Distance In Feet
55	2.3	20 gauge	45
		18 gauge	60
		16 gauge	100
		14 gauge	160
		12 gauge	250

**TABLE 6
WALL THERMOSTAT**

Thermostat	Predominate Features
8403-049 (1F93-380)	2 stage Cool; 2 stage Heat Programmable Electronic Auto or Manual changeover
8403-057 (TH5220D1153)	1 stage Cool; 1 stage Heat Electronic Non-Programmable Auto or Manual changeover
8403-058 (TH5220D1151)	2 stage Cool; 2 stage Heat Electronic Non-Programmable Auto or Manual changeover

**FIGURE 4
ELECTRIC HEAT CLEARANCE**

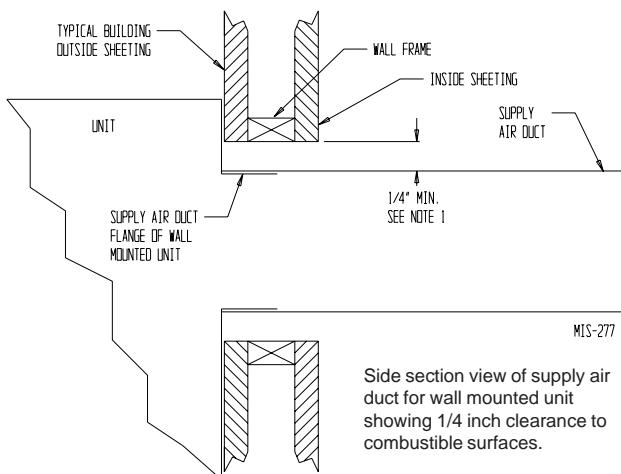

WARNING

- A minimum of 1/4 inch clearance must be maintained between the supply air duct and combustible materials. This is required for the first 3 feet of ducting.
- It is important to insure that the 1/4 inch minimum spacing is maintained at all points.
- Failure to do this could result in overheating the combustible material and may result in fire.

**FIGURE 5
WALL-MOUNTING INSTRUCTIONS**

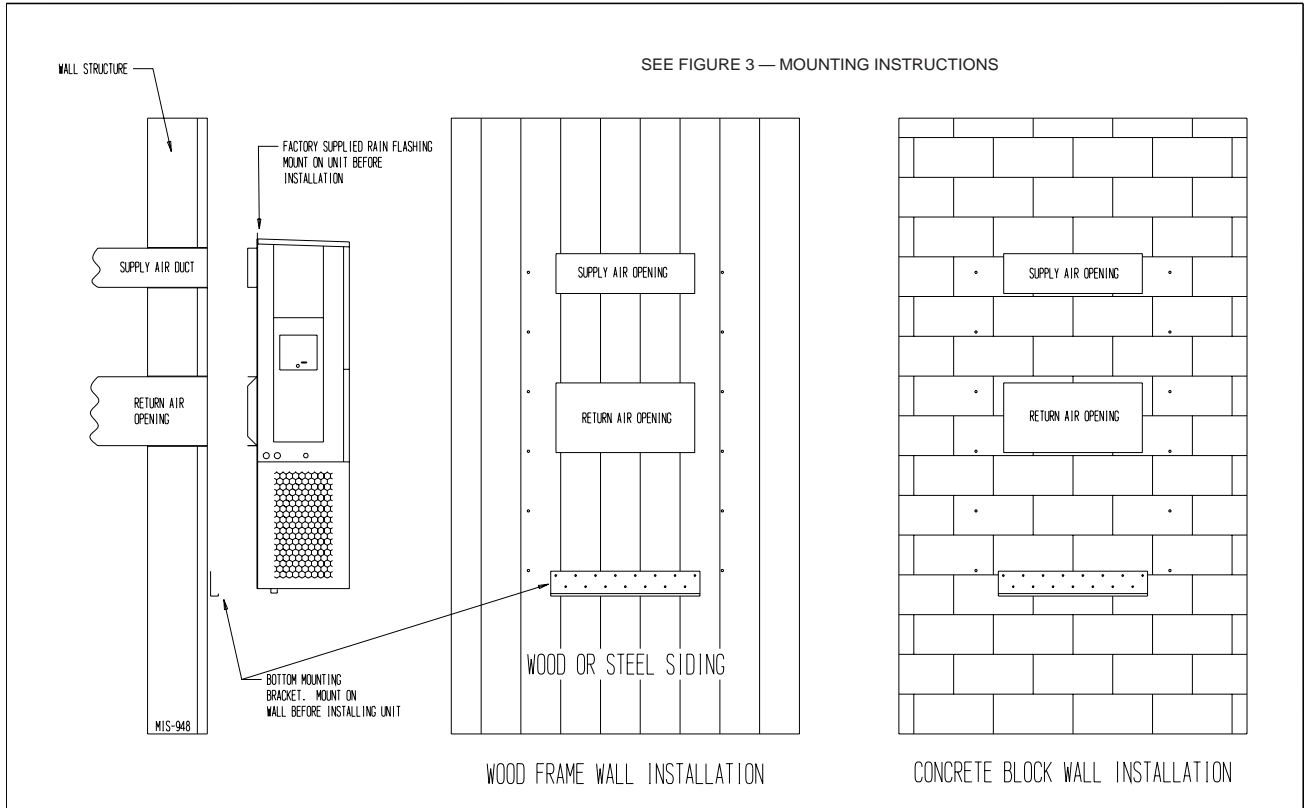

**FIGURE 6
WALL-MOUNTING INSTRUCTIONS**

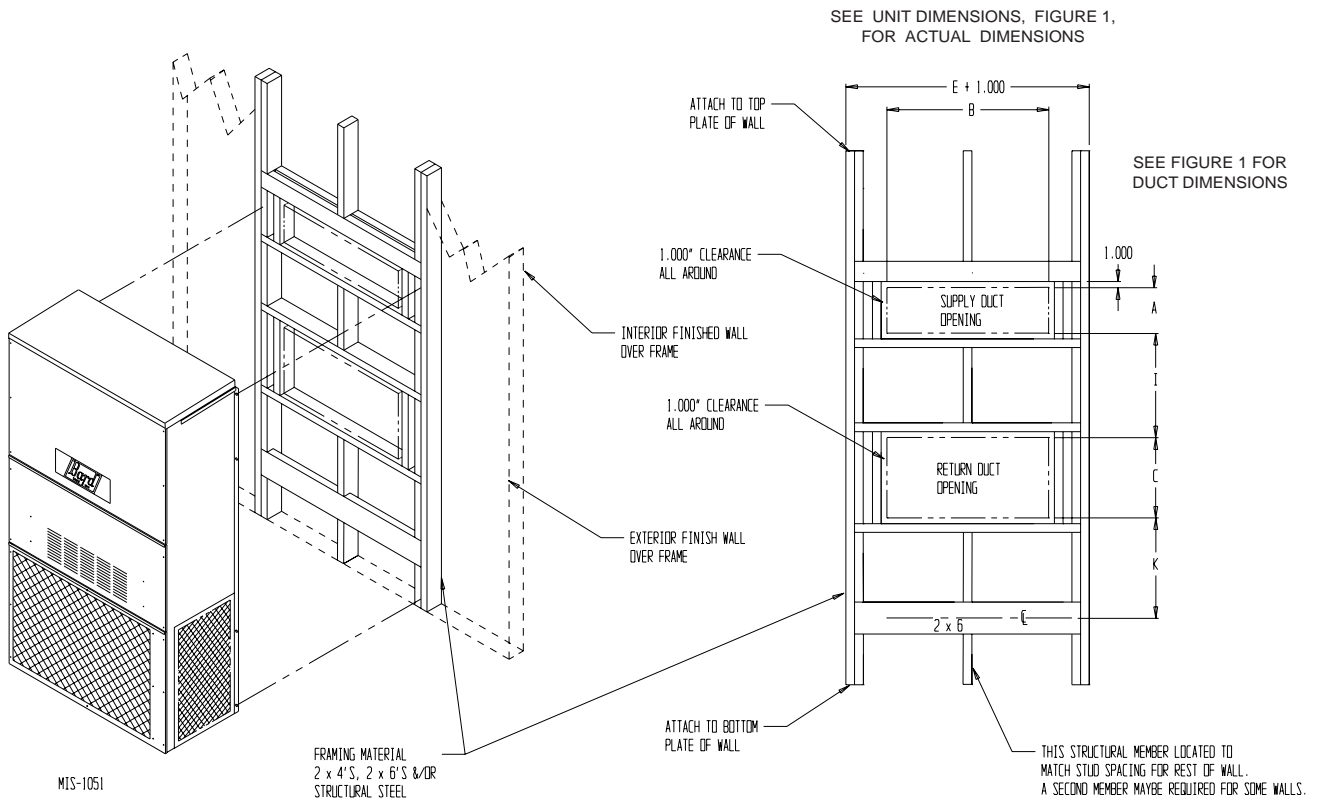

**FIGURE 7
COMMON WALL-MOUNTING INSTALLATIONS**

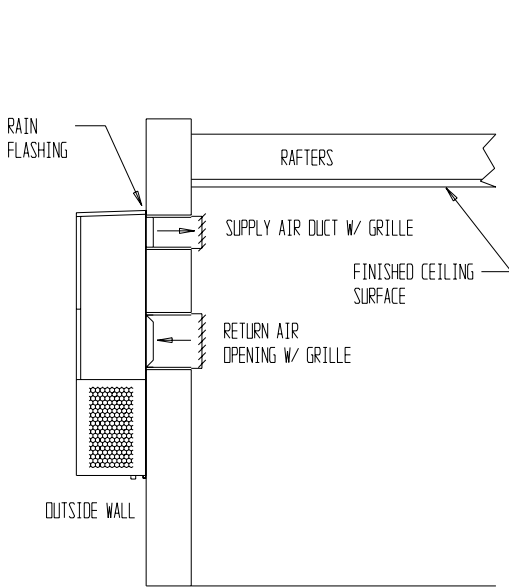

FREE AIR FLOW
NO DUCT

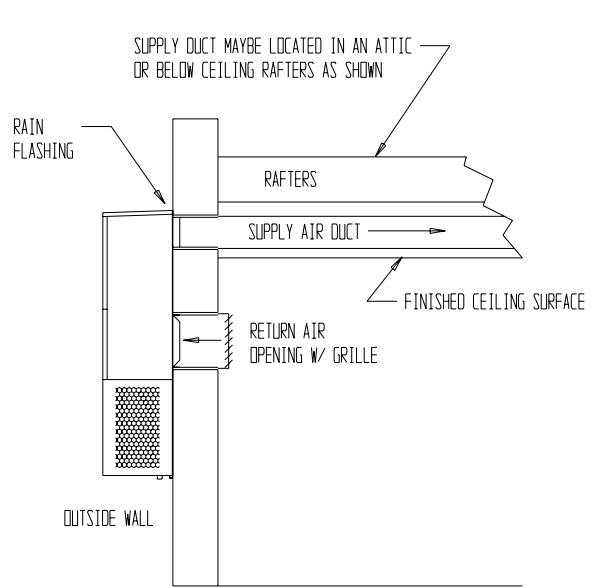

DUCTED SUPPLY
RETURN AT UNIT

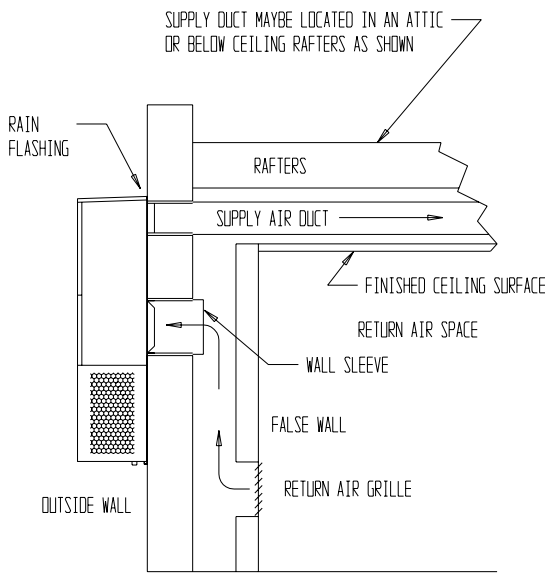

FALSE WALL INSTALLATION

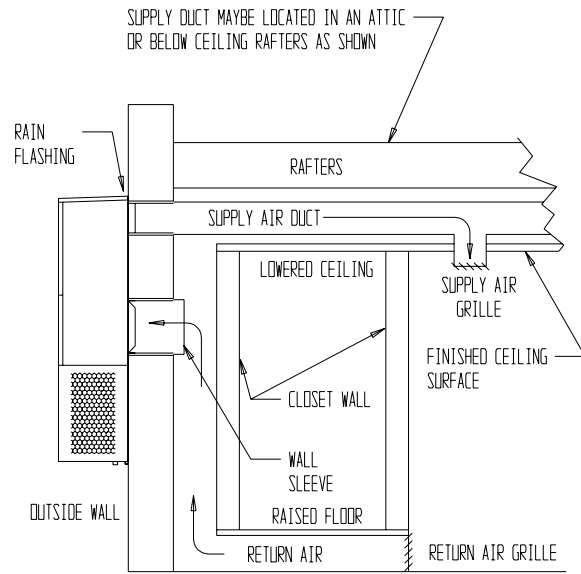

CLOSET INSTALLATION

MIS-1050

**FIGURE 8
LOW VOLTAGE WIRING**

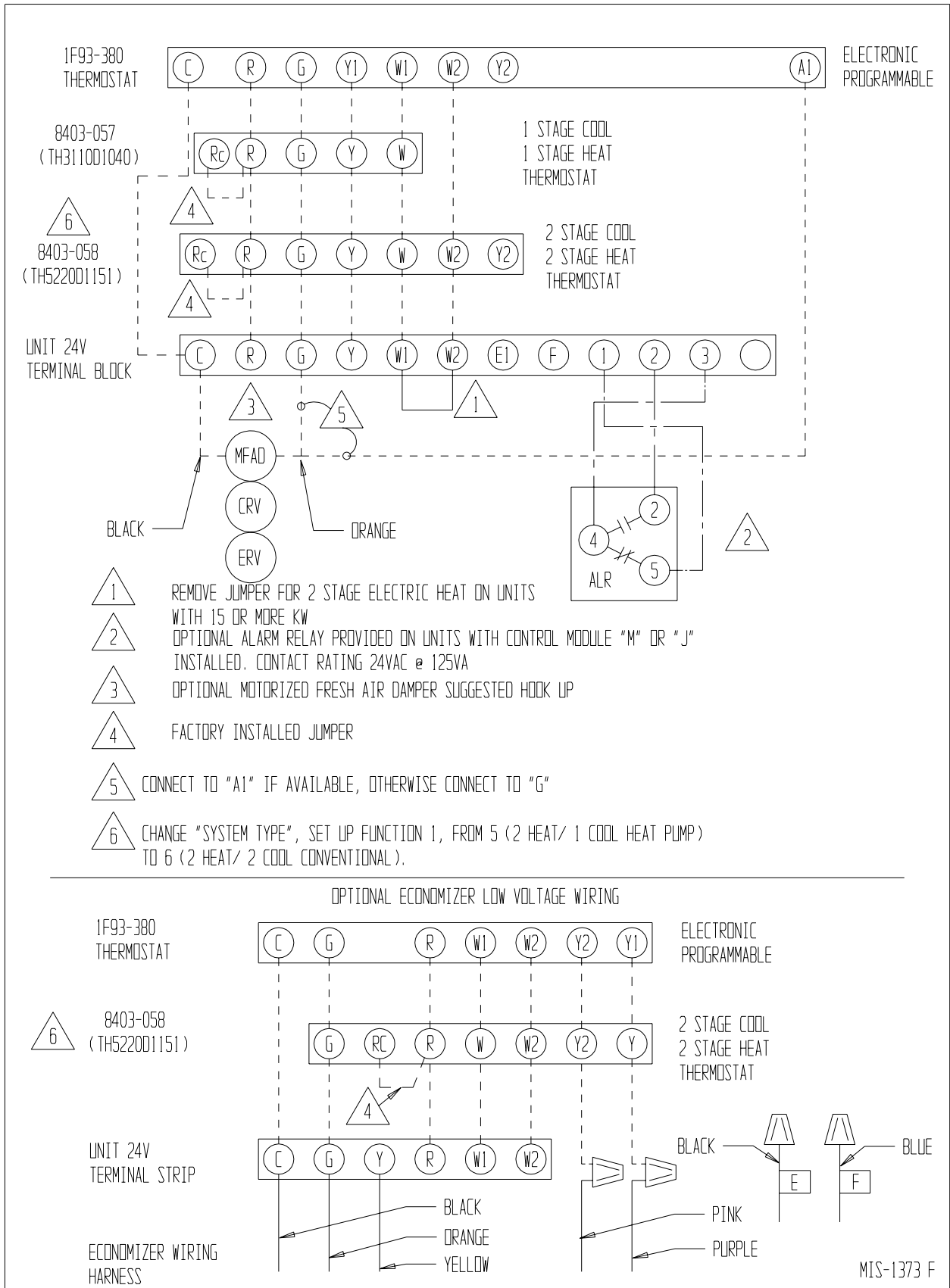

START UP

IMPORTANT INSTALLER NOTE

For improved start-up performance, wash the indoor coil with a dishwasher detergent.

CRANKCASE HEATERS

WL701 & WL721 units are provided with compressor crankcase heat.

The WL701 and WL721 models have a band type heater located around the bottom of the compressor. This heater is controlled by the crankcase heater relay. The heater is only energized when the compressor is not running.

Some form of crankcase heat is essential to prevent liquid refrigerant from migrating to the compressor, causing oil pump out on compressor start-up and possible valve failure due to compressing a liquid.

The decal in Figure 9 is affixed to all WL701 & WL721 units detailing start-up procedure. This is very important. Please read carefully.

FIGURE 9
START-UP LABEL

IMPORTANT

These procedures must be followed at initial start-up and at any time power has been removed for 12 hours or longer.

To prevent compressor damage which may result from the presence of liquid refrigerant in the compressor crankcase.

1. Make certain the room thermostat is in the "off" position (the compressor is not to operate).
2. Apply power by closing the system disconnect switch. This energizes the compressor heater which evaporates the liquid refrigerant in the crankcase.
3. Allow 4 hours or 60 minutes per pound of refrigerant in the system as noted on the unit rating plate, whichever is greater.
4. After properly elapsed time, the thermostat may be set to operate the compressor.
5. Except as required for safety while servicing – **Do not open system disconnect switch.**

7961-061

HIGH PRESSURE SWITCH

The WL701, WL702 and WL721 models are supplied with a remote reset high pressure switch. If tripped, this pressure switch may be reset by turning the thermostat off then back on again.

THREE PHASE SCROLL COMPRESSOR START UP INFORMATION

Scroll compressors, like several other types of compressors, will only compress in one rotational direction. Direction of rotation is not an issue with single phase compressors since they will always start and run in the proper direction.

However, three phase compressors will rotate in either direction depending upon phasing of the power. Since there is a 50-50 chance of connecting power in such a way as to cause rotation in the reverse direction, verification of proper rotation must be made. All three phase units incorporate a phase monitor to ensure proper field wiring. See the Phase Monitor section in this manual.

Verification of *proper rotation* must be made any time a compressor is change or rewired. If improper rotation is corrected at this time there will be no negative impact on the durability of the compressor. However, reverse operation for over one hour may have a negative impact on the bearing due to oil pump out.

NOTE: If compressor is allowed to run in reverse rotation for several minutes, the compressor's internal protector will trip.

All three phase ZR3 compressors are wired identical internally. As a result, once the correct phasing is determined for a specific system or installation, connecting properly phased power leads to the same Fusite terminal should maintain proper rotation direction.

Verification of proper rotation direction is made by observing that suction pressure drops and discharge pressure rises when the compressor is energized. Reverse rotation also results in an elevated sound level over that with correct rotations, as well as, substantially reduced current draw compared to tabulated values.

The direction of rotation of the compressor may be changed by reversing any two line connections to the unit.

SERVICE HINTS

1. Caution homeowner to maintain clean air filters at all times. Also, not to needlessly close off supply and return air registers. This reduces airflow through the system, which shortens equipment service life as well as increasing operating costs.
2. Check all power fuses or circuit breakers to be sure they are the correct rating.
3. Periodic cleaning of the outdoor coil to permit full and unrestricted airflow circulation is essential.

SEQUENCE OF OPERATION

Cooling—Circuit R-Y makes at thermostat pulling in compressor contactor, starting the compressor and outdoor motor. The G (indoor motor) circuit is automatically completed on any call for cooling operation or can be energized by manual fan switch on subbase for constant air circulation. On all 208/230 volt models, when G circuit is de-energized the indoor blower motor will continue to run for one minute. On a call for heating, circuit R-W1 make at the thermostat pulling in heat contact for the strip heat and blower operation. On a call for second stage heat, R-W2 makes bringing on second heat contactor, if so equipped.

COMPRESSOR CONTROL MODULE

The compressor control module is standard on the models covered by this manual. The compressor control is an anti-short cycle/lockout timer with high and low pressure switch monitoring and alarm relay output.

Adjustable Delay On Make And Break Timer

On initial power up or any time power is interrupted to the unit, the *delay on make* period begins, which will be 2 minutes plus 10% of the *delay on break* setting. When the delay on make is complete and the high pressure switch (and low pressure switch if employed) is closed, the compressor contactor is energized. Upon shutdown, the delay or break timer starts and prevents restart until the delay on break and delay on make periods have expired.

During routine operation of the unit with no power interruptions the compressor will operate on demand with no delay.

High Pressure Switch and Lockout Sequence

If the high pressure switch opens, the compressor contactor will de-energize immediately. The lockout timer will go into a *soft lockout* and stay in soft lockout until the high pressure switch closes and the delay on break time has expired. If the high pressure switch opens again in this same operating cycle the unit will go into *manual lockout* condition and the alarm relay circuit will energize. Recycling the wall thermostat resets the manual lockout.

Low Pressure Switch, Bypass, and Lockout Sequence

If the low pressure switch opens for more than 120 seconds, the compressor contactor will de-energize and go into a soft lockout. Regardless the state of the low pressure switch, the contactor will reenergize after the delay on make time delay has expired. If the low pressure switch remains open, or opens again for longer than 120 seconds the unit will go into manual lockout condition and the alarm relay circuit will energize. Recycling the wall thermostat resets the manual lockout.

Alarm Relay Output

Alarm terminal is output connection for applications where alarm relay is employed. This terminal is powered whenever compressor is locked out due to HPC or LPC sequences as described.

NOTE: Both high and low pressure switch controls are inherently automatic reset devices. The high pressure switch and low pressure switch cut out and cut in settings are fixed by specific air conditioner or heat pump unit model. The lockout features, both soft and manual, are a function of the Compressor Control Module.

ADJUSTMENTS

Adjustable Delay on Make and Delay on Break Timer

The potentiometer is used to select Delay on Break time from 30 seconds to 5 minutes. Delay on Make (DOM) timing on power-up and after power interruptions is equal to 2 minutes plus 10% of Delay on Break (DOB) setting:

0.5 minute (30 seconds)	DOB = 123 second	DOM
1.0 minute (60 seconds)	DOB = 126 second	DOM
2.0 minute (120 seconds)	DOB = 132 second	DOM
3.0 minute (180 seconds)	DOB = 138 second	DOM
4.0 minute (240 seconds)	DOB = 144 second	DOM
5.0 minute (300 seconds)	DOB = 150 second	DOM

During routine operation of the unit with no power interruptions the compressor will operate on demand with no delay.

Typical Settings for Dual Unit Installation:

Unit 1: DOB set at 2 minutes, and DOM is 132 seconds

Unit 2: DOB set at 4 minutes, and DOM is 144 seconds

PHASE MONITOR

All units with three phase scroll compressors are equipped with a 3 phase line monitor to prevent compressor damage due to phase reversal.

The phase monitor in this unit is equipped with two LEDs. If the Y signal is present at the phase monitor and phases are correct the green LED will light.

If phases are reversed, the red fault LED will be lit and compressor operation is inhibited.

If a fault condition occurs, reverse two of the supply leads to the unit. Do not reverse any of the unit factory wires as damage may occur.

PRESSURE SERVICE PORTS

High and low pressure service ports are installed on all units so that the system operating pressures can be observed. Pressure tables can be found later in the manual covering all models. It is imperative to match the correct pressure table to the unit by model number.

TROUBLESHOOTING

FAN BLADE SETTING DIMENSIONS

Shown in the drawing below are the correct fan blade setting dimensions for proper air delivery across the outdoor coil.

Any service work requiring removal or adjustment in the fan and/or motor area will require that the dimensions below be checked and blade adjusted in or out on the motor shaft accordingly.

**FIGURE 10
FAN BLADE SETTING**

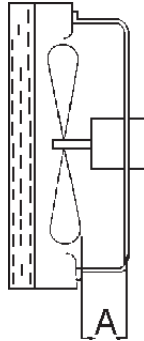

**TABLE 7
FAN BLADE DIMENSIONS**

Model	Dimension A
WL70, 72	1.25

The suction line temperatures in Table 8 are based upon 80°F dry bulb/67°F wet bulb (50 percent R.H.) temperature and rated airflow across the evaporator during cooling cycle.

**TABLE 9
INDOOR BLOWER PERFORMANCE
CFM AT 230 V**

E.S.P. In H ₂ O	WL70 , WL72			
	High Speed		Low Speed	
	Dry Coil	Wet Coil	Dry Coil	Wet Coil
.0	2,200	2,000	1,600	1,450
.1	2,100	1,900	1,525	1,375
.2	2,000	1,800	---	---
.3	1,875	1,700	---	---
.4	1,775	1,600	---	---
.5	1,650	1,475	---	---

REMOVAL OF FAN SHROUD

1. Disconnect all power to unit.
2. Remove the screws holding both grills – one on each side of unit – and remove grills.
3. Remove screws holding fan shroud to condenser and bottom – (9) screws.
4. Unwire condenser fan motor.
5. Slide complete motor, fan blade, and shroud assembly out the left side of the unit.
6. Service motor/fan as needed.
7. Reverse steps to reinstall.

**TABLE 10
CFM AND ESP**

Rated Model	Rated CFM	Recommended ESP	Air Flow Range
WL70, 72	1,800	.20	2,000 -- 1,375

Ⓢ Rated CFM and ESP on high speed tap.

REFRIGERANT CHARGE

The correct system R-22 charge is shown on the unit rating plate. Optimum unit performance will occur with a refrigerant charge resulting in a suction line temperature (6 inches from compressor) as shown in the following table:

**TABLE 8
SUCTION LINE TEMPERATURES**

Ⓢ Models	Rated Airflow	95° F OD Temp.	82° F OD Temp.
WL70, 72	1,800	58 - 60	56 - 58

**TABLE 11
MAXIMUM ESP OF OPERATION
ELECTRIC HEAT ONLY**

Model	WL70 , WL72	
	Low Speed	High Speed
-A00	.50	.50
-A05	.50	.50
-A10	.50	.50
-B00	.50	.50
-B09	.50	.50
-B15	.50	.50
-C09	.50	.50
-C15	.50	.50

**TABLE 12
COOLING PRESSURE – (ALL TEMPERATURES °F)**

Model	Return Air Temp.	Pressure	75	80	85	90	95	100	105	110	115
WL702-A	75 DB 62 WB	Low Side High Side	68 215	68 228	69 242	70 256	71 272	72 289	73 305	74 324	75 343
	80 DB 67 WB	Low Side High Side	73 220	73 234	74 248	75 263	76 279	77 296	78 313	79 332	80 352
	85 DB 72 WB	Low Side High Side	76 228	76 242	77 257	78 272	79 289	80 306	81 324	82 344	83 364
WL701-B,-C WL721-B	75 DB 62 WB	Low Side High Side	62 214	63 230	64 247	65 265	66 280	67 299	68 316	69 333	70 351
	80 DB 67 WB	Low Side High Side	67 220	68 236	69 254	70 271	71 287	72 306	73 324	74 342	75 360
	85 DB 72 WB	Low Side High Side	72 225	73 243	74 261	75 279	76 297	77 316	78 335	79 353	80 372

Low side pressure ± 2 psig
High side pressure ± 5 psig

Tables are based upon rated CFM (airflow) across the evaporator coil. If there is any doubt as to correct operating charge being in the system, the charge should be removed, system evacuated and recharged to serial plate instruction.

**TABLE 13
OPTIONAL ACCESSORIES**

MODEL	DESCRIPTION	WL702-A	WL701-B, WL721-B	WL701-C
EHWA05-A05L	Heater Package	X		
EHWA10-A10L	Heater Package	X		
EHWA15-A15L	Heater Package	X		
EHWA05-B09L	Heater Package		X	
EHWA05-B15L	Heater Package		X	
EHWA05A-C09L	Heater Package			X
EHWA05A-C15L	Heater Package			X
BOP-5	Blank Off Plate	X	X	X
BFAD-5	Barometric Fresh Air Damper	X	X	X
MFAD-5	Motorized Fresh Air Damper	X	X	X
CRV-5	Classroom Ventilator with Exhaust	X	X	X
EIFM-5	Economizer with Exhaust	X	X	X
WERV-A5A	Energy Recovery Ventilator	X	X	
WERV-C5A	Energy Recovery Ventilator			X
WMPD-01C	Pull Disconnect Kit			X