

INSTALLATION INSTRUCTIONS

QW SERIES WALL SLEEVE (THROUGH WINDOW OPENING)

Model: QWVSR42

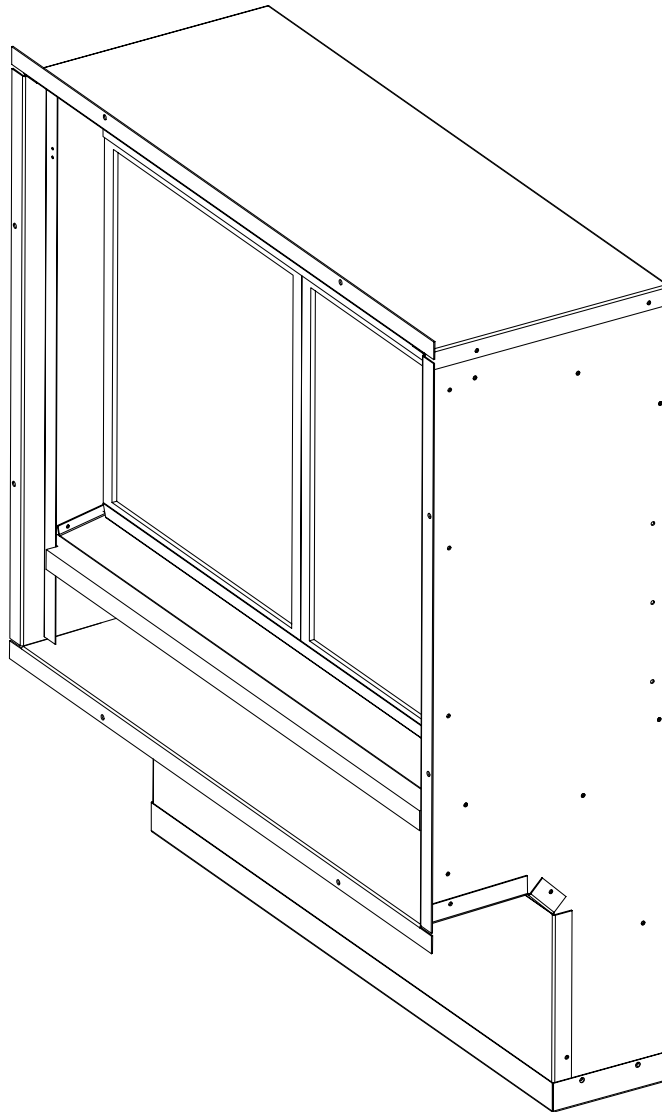

MIS-1828



CLIMATE CONTROL SOLUTIONS

Bard Manufacturing Company
Bryan, Ohio 43506

Since 1914...Moving ahead, just as planned.

Manual No.: 2100-433

Supersedes:

File: Vol. II Tab 14

Date: 04-17-03

CONTENTS

Getting Other Information and Publications 1
Shipping Damage 2
General 2
Installation of Wall Sleeve 2

Figures
Figure 1 Placement of Unit to Wall 3
Figure 2 Wall Sleeve Mounting Bracket Detail 4
Figure 3 Silicone Sealing of Wall Sleeve 5
Figure 4 Mounting Sleeve Angles to
BlankOff Board 6

Getting Other Information and Publications

These publications can help you install the air conditioner or heat pump. You can usually find these at your local library or purchase them directly from the publisher. Be sure to consult current edition of each standard.

Standard for the Installation ANSI/NFPA 90A
of Air Conditioning and
Ventilating Systems

Standard for Warm Air ANSI/NFPA 90B
Heating and Air
Conditioning Systems

QW Installation Instruction Manual Bard/2100-381

FOR MORE INFORMATION, CONTACT THESE PUBLISHERS:

ACCA **Air Conditioning Contractors of America**
1712 New Hampshire Avenue, NW
Washington, DC 20009
Telephone: (202) 483-9370
Fax: (202) 234-4721

ANSI **American National Standards Institute**
11 West Street, 13th Floor
New York, NY 10036
Telephone: (212) 642-4900
Fax: (212) 302-1286

ASHRAE **American Society of Heating, Refrigerating,
and Air Conditioning Engineers, Inc.**
1791 Tullie Circle, N.E.
Atlanta, GA 30329-2305
Telephone: (404) 636-8400
Fax: (404) 321-5478

BARD **Bard Manufacturing Company**
1914 Randolph Drive
Bryan, OH 43506
Telephone: (419) 636-1194
Fax: (419) 636-2640

SHIPPING DAMAGE

Upon receipt of equipment, the carton should be checked for external signs of shipping damage. If damage is found, the receiving party must contact the last carrier immediately, preferably in writing, requesting inspection by the carrier's agent.

GENERAL

The QWVSR42 Wall Sleeve is designed for use with QW Series Water to Air Heat Pumps for an application through a window opening.

The equipment covered in this manual is to be installed by trained service and installation technicians.

These instructions explain the recommended method to install the wall sleeve.

These instructions and any instructions packaged with any separate equipment required to make the entire air conditioning system should be carefully read before beginning the installation.

While these instructions are intended as a general recommended guide, they do not supersede any national and/or local codes in any way. Authorities having jurisdiction should be consulted before the installation is made.

INSTALLATION OF WALL SLEEVE

See Figure 1 for general placement of unit to wall. Maximum windowsill height for use of the QWVSR42 as measured from the floor inside of the building where the QW unit is setting is 42 inches.

Unlock the rollers on the QW unit and roll the unit near the window.

The wall sleeve will be attached to the unit with two mounting brackets that are provided. (See Figure 2.) Attach the brackets to the wall sleeve by driving the screws from the inside out. Position sleeve to unit and measure from the floor up 33-3/8 inches. Drill six (6) 1/8" diameter holes in the cabinet through the brackets and attach with screws. Twelve (12) screws are provided.

Roll the unit up to the window; center on blank off board; and mark around the mounting flanges of the sleeve. Pull the unit away from the window and cut the opening 1 inch smaller on all four sides.

The bottom of the sleeve is located below the windowsill so any rainwater that enters the sleeve must be drained into the building drain system. There is a drain connection provided in the right side of the wall sleeve. The connection size is a 3/4" pipe coupling.

At this point you may chose to attach the drain. If a flexible connection is to be used, a "P" trap is not required.

Apply a bead of silicone around the mounting flange of the sleeve that will mate up to the window blank off board. (See Figure 3.) Roll unit up to the window and attach with field-supplied screws.

There are four sheet metal angles provided to cover the raw edge of the opening in the window blank off board. They are to be attached to the window blank off board with field-supplied screws. Seal these angles to the sleeve with silicone. (See Figure 4.)

The wall mounting brackets that are supplied to attach the QW unit to the wall are not long enough for this type of installation. They will need to be modified or field-fabricated.

Attach outdoor louver grille with the (4) 1-1/2" long screws provided with this sleeve.

Discard side trim pieces supplied with the QW unit.. Install side extension kit model QSTX42A-V for platinum vinyl or QSTX42XA-4 for gray paint. These extension kits are purchased separately.

**FIGURE 1
PLACEMENT OF UNIT TO WALL**

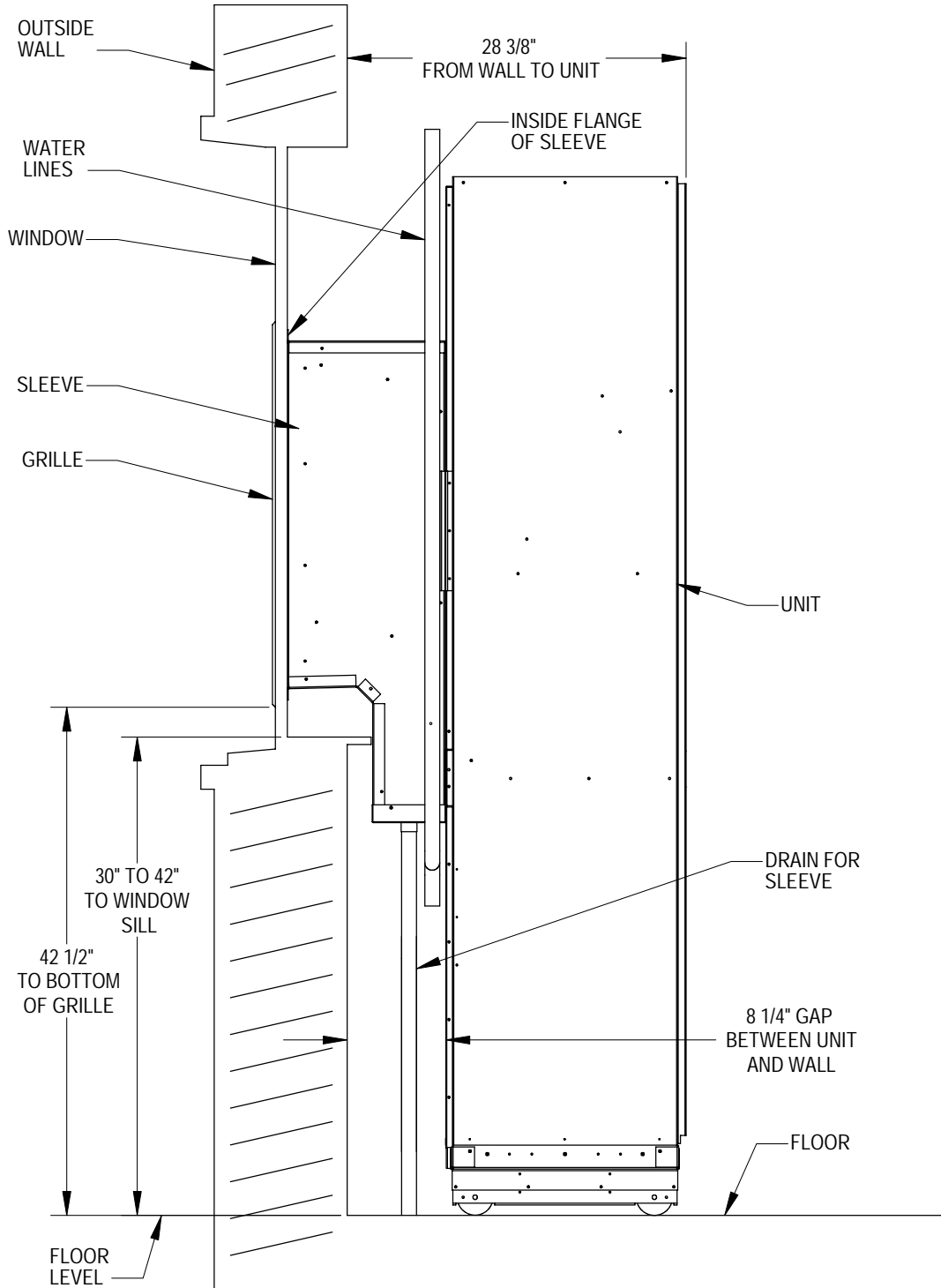

MIS-1829

FIGURE 2
WALL SLEEVE MOUNTING BRACKET DETAIL

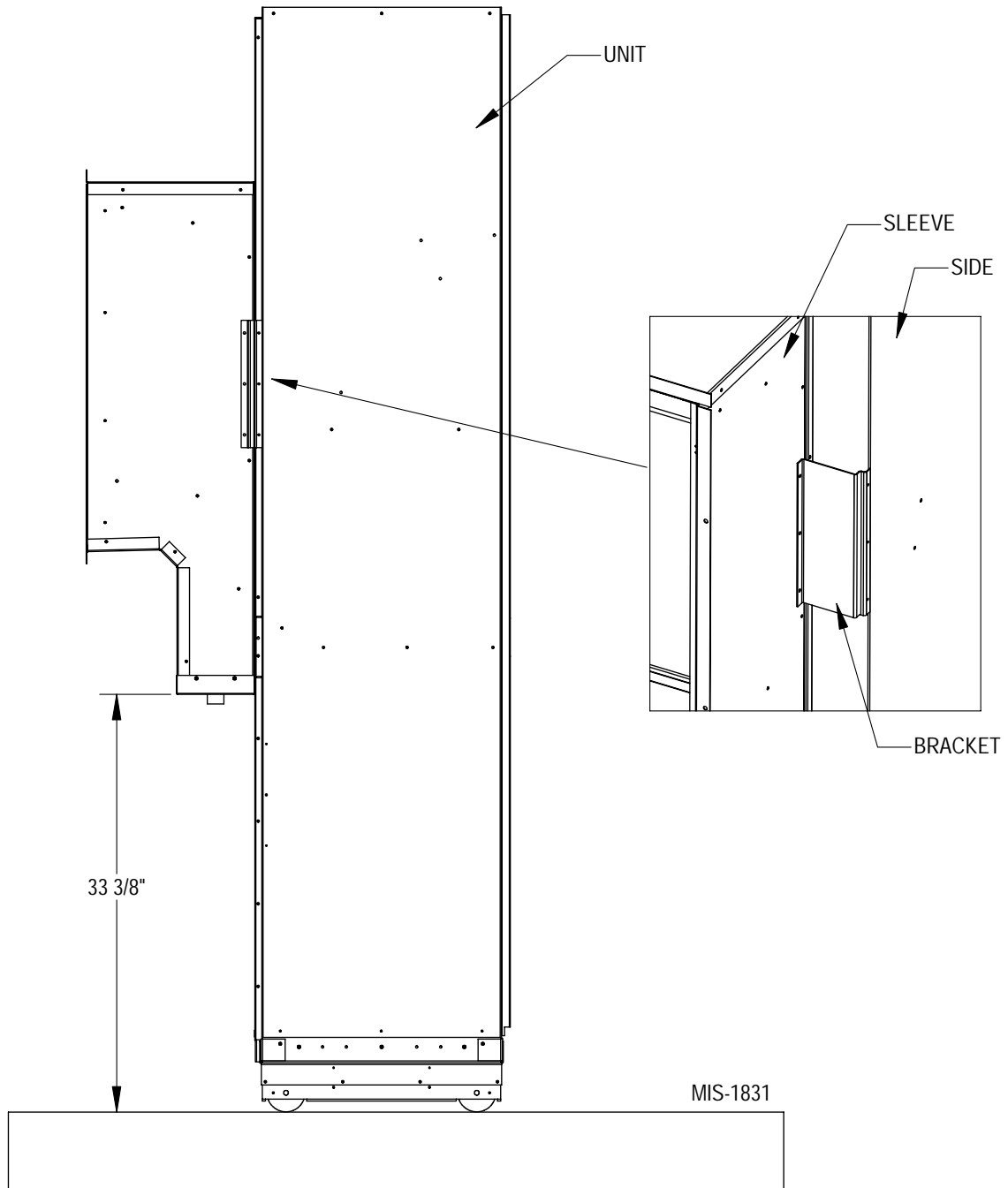

FIGURE 3
SILICONE SEALING OF WALL SLEEVE

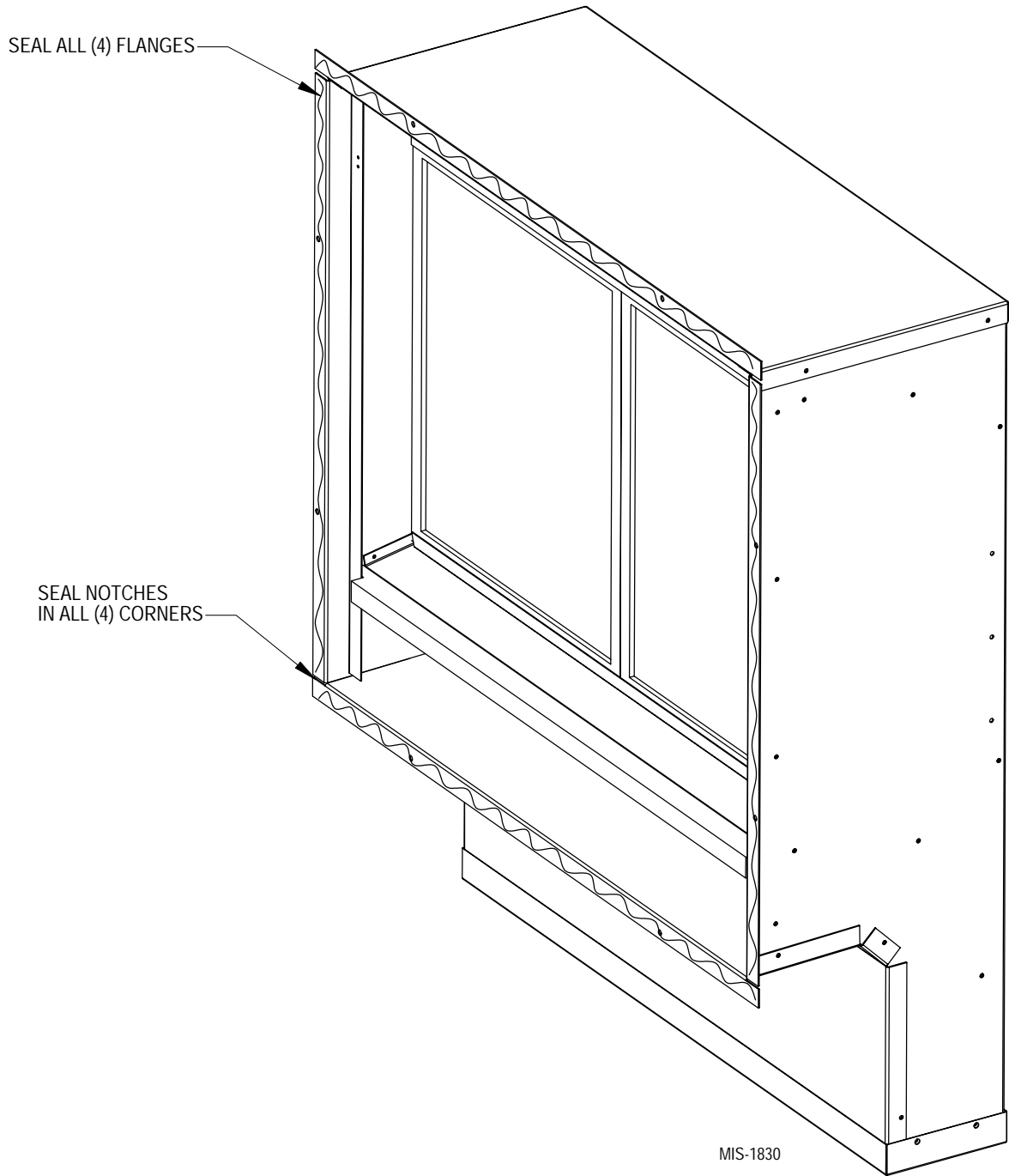
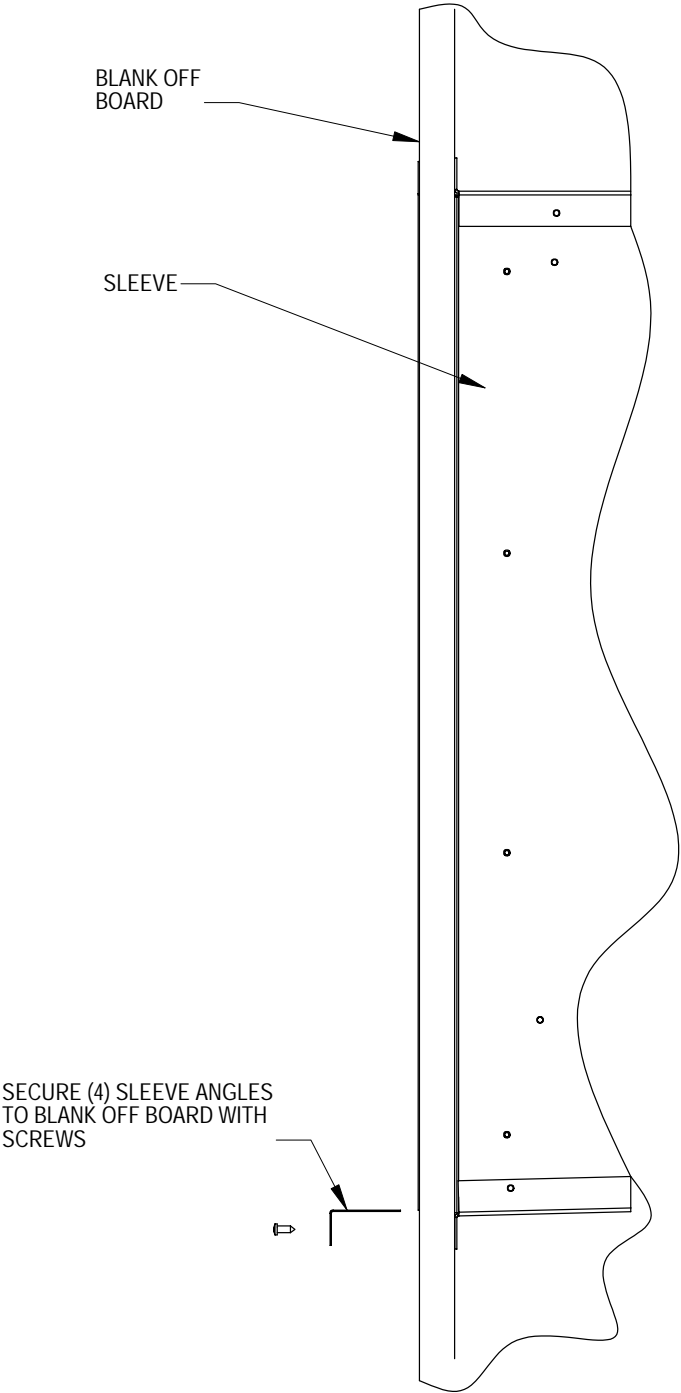

FIGURE 4
MOUNTING SLEEVE ANGLES TO BLANK OFF BOARD



MIS-1832