

INSTALLATION INSTRUCTIONS

Q-TEC Wall Sleeve Model: QWS48A-H19

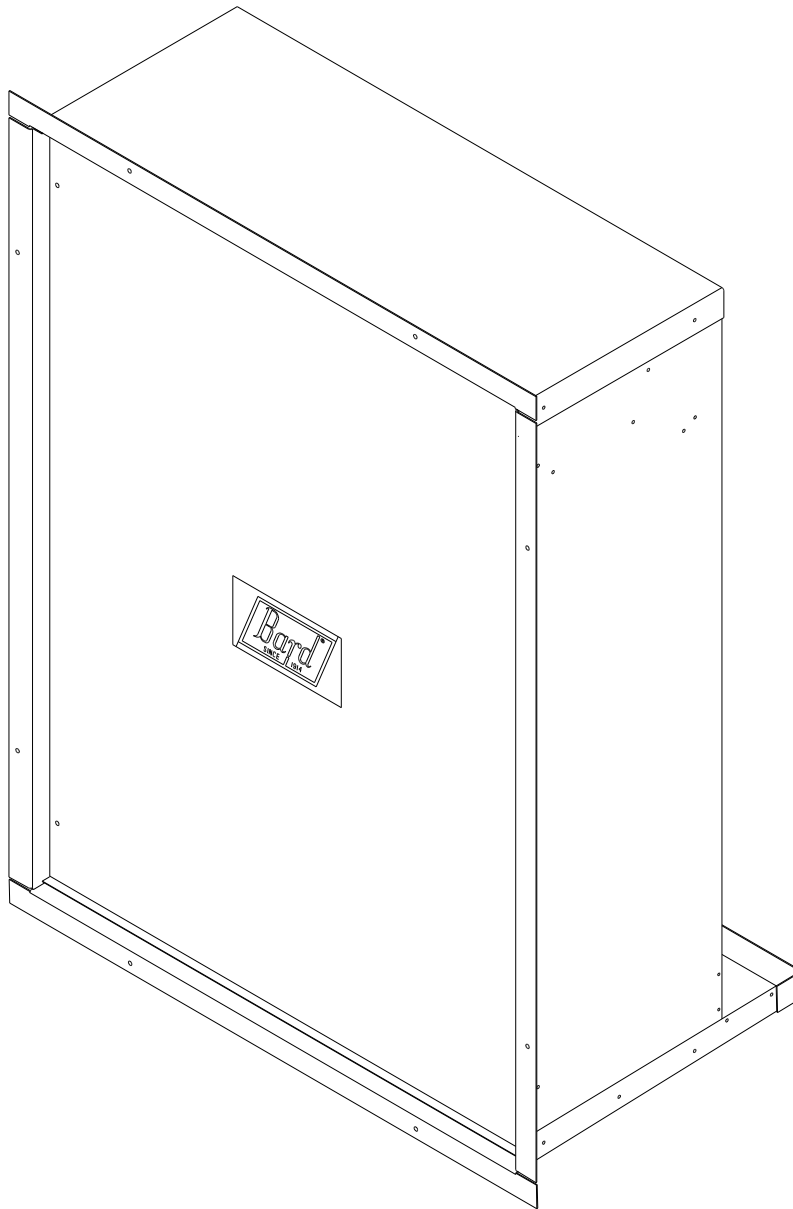

MIS-964



Bard Manufacturing Company, Inc.
Bryan, Ohio 43506
Since 1914...Moving, ahead just as planned.

Manual: 2100-434E
Supersedes: 2100-434D
File: Volume II, Tab 14
Date: 05-25-12

CONTENTS

Getting Other Information and Publications 3

Q-TEC Wall Sleeve General Information

- Shipping Damage4
- General Information4

Installation Instructions

- Installation Wood Framed Walls 4 & 6
- Installation Masonry Construction Walls 6 & 7
- Accessory Item – QCDS48A-H19
- Condensate Disposal System8
- Attachment of Wall Sleeve to QTec Unit9

Figures

- Figure 1 Wood Framed Installation.....4
- Figure 2 Application of Sealant to 2x6 Plate.....5
- Figure 3 Application of Sealant to Flanges5
- Figure 4 Masonry Construction Installation6
- Figure 5 Typical Installation with 14”
Maximum Wall Thickness7
- Figure 6 QCDS48 Condensate Disposal
System.....8

Copyright May 2003
Bard Manufacturing Company, Inc.
Bryan, Ohio 43506

Getting Other Information and Publications

These publications can help you install the air conditioner or heat pump. You can usually find these at your local library or purchase them directly from the publisher. Be sure to consult current edition of each standard.

Standard for the Installation ofANSI/NFPA 90A
Air Conditioning and Ventilating Systems

Standard for Warm Air HeatingANSI/NFPA 90B
Air Conditioning Systems

Q-TEC Installation Instruction Manual . Bard/2100-288

FOR MORE INFORMATION, CONTACT THESE PUBLISHERS:

ACCA **Air Conditioning Contractors of America**
1712 New Hampshire Avenue, NW
Washington, DC 20009
Telephone: (202) 483-9370
Fax: (202) 234-4721

ANSI **American National Standards Institute**
11 West Street, 13th Floor
New York, NY 10036
Telephone: (212) 642-4900
Fax: (212) 302-1286

ASHRAE **American Society of Heating Refrigerating,
& Air Conditioning Engineers, Inc.**
1791 Tullie Circle, N.E.
Atlanta, GA 30329-2305
Telephone: (404) 636-8400
Fax: (404) 321-5478

BARD **Bard Manufacturing Company, Inc.**
1914 Randolph Drive
Bryan, OH 43506
Telephone: (419) 636-1194
Fax: (419) 636-2640

SHIPPING DAMAGE

Upon receipt of equipment, the carton should be checked for external signs of shipping damage. If damage is found, the receiving party must contact the last carrier immediately, preferably in writing requesting inspection by the carrier's agent.

GENERAL

The QWS48 series is designed for use with the Q-TEC Series Air Conditioners and Air Source Heat Pumps. The QWS48A-H19 is for use with wall thickness of 5 to 18 inches. One QWS48A-H19 series wall sleeve is required for each heat pump to be installed.

The equipment covered in this manual is to be installed by trained service and installation technicians.

These instructions explain the recommended method to install the wall sleeve.

These instructions and any instructions packaged with any separate equipment required to make the entire air conditioning system should be carefully read before beginning the installation.

While these instructions are intended as a general recommended guide, they do not supersede any national and/or local codes in any way. Authorities having jurisdiction should be consulted before the installation is made.

INSTALLATION – WOOD FRAMED WALLS

For wood frame construction walls, the dimensions of the opening must be 48 inches tall by 43 inches wide. A 2 x 6 header will be required for the opening. The sides of the opening must have trimmer studs to support the header, and to provide a structural member on which to fasten the sleeve. (See Figure 1.) All of the dimensions are referenced from the finished floor height.

After the opening is framed in, a treated 2 x 6 bottom support and seal plate must be cut to fit in the bottom of the opening. Construction adhesive should be applied to the 2 x 6 before it is put in place. (See Figure 2.) This will help hold the plate in place and provide an additional seal for the bottom of the opening. The treated 2 x 6 must be fastened to the bottom of the opening flush to the finished surface of the outside wall. The 2 x 6 must be sealed to the outside wall with construction adhesive. Any gaps between the sides of the 2 x 6 plate and the opening must also be sealed. See Figure 2.

NOTE: The actual thickness of 2 x 6 must be 1-1/2".

Once the opening is framed, the sheathing can be installed, the sheathing material must not extend into the opening.

The sleeve should be test fit into the opening to make sure of the dimensions. The sleeve must be inserted into the opening from the outside of the building. The bottom of the sleeve must be level from side to side, and the sleeve must be square in the opening. A slope is built into the bottom of the sleeve from the inside to the outside. This will allow any water that gets into the sleeve to drain out. Once the test fit is completed, the sleeve must be removed from the opening, and two 1/4 inch beads of sealant must be applied to the mounting flanges of the sleeve. (See Figure 3.)

**FIGURE 1
WOOD FRAMED INSTALLATION**

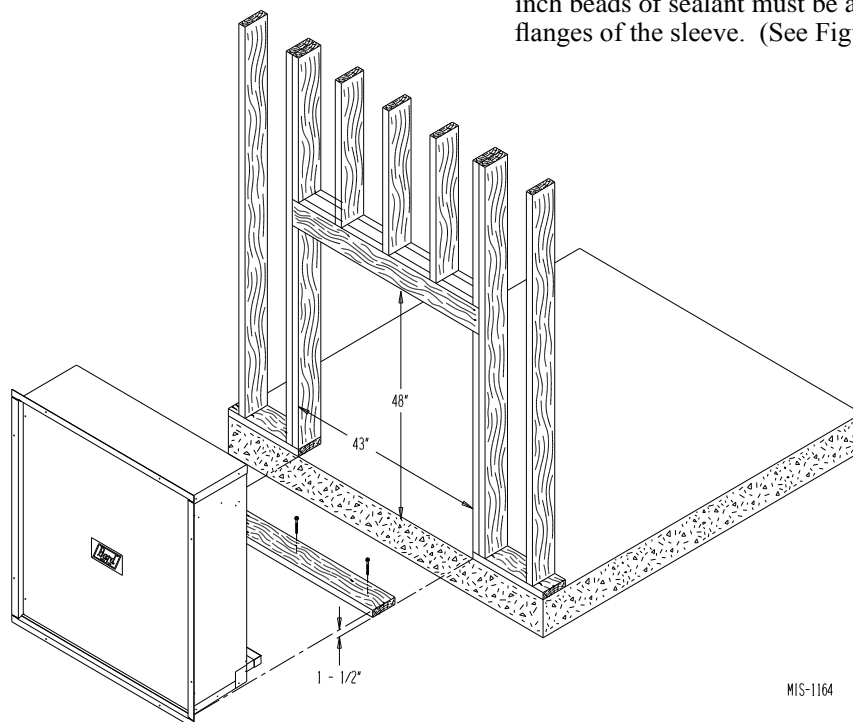

MIS-1164

FIGURE 2
APPLICATION OF SEALANT TO 2 X 6 PLATE

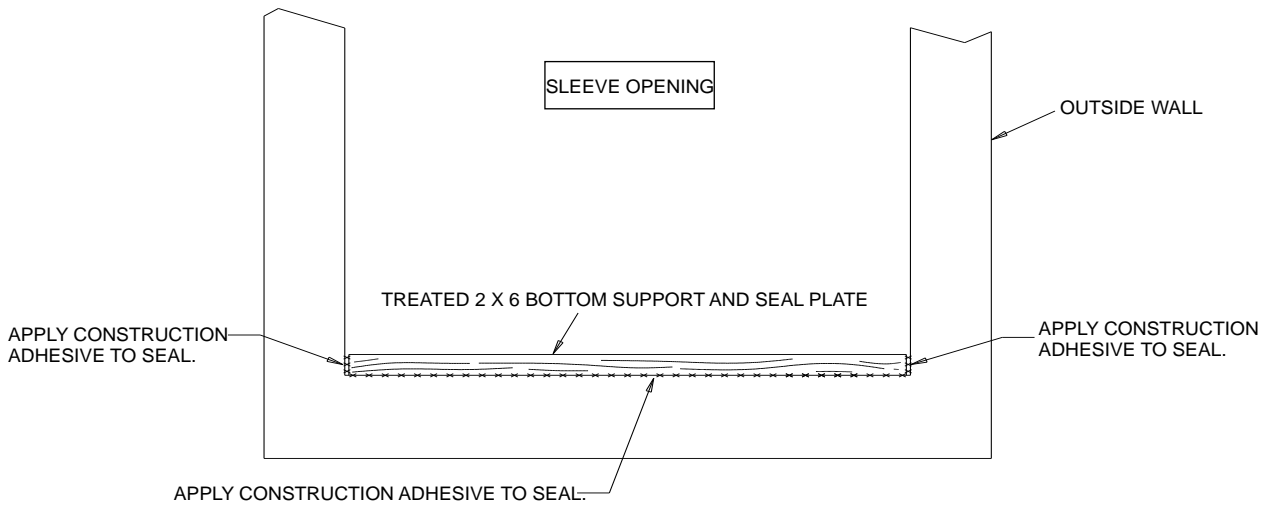

FRONT VIEW

MIS-968

FIGURE 3
APPLICATION OF SEALANT TO FLANGES

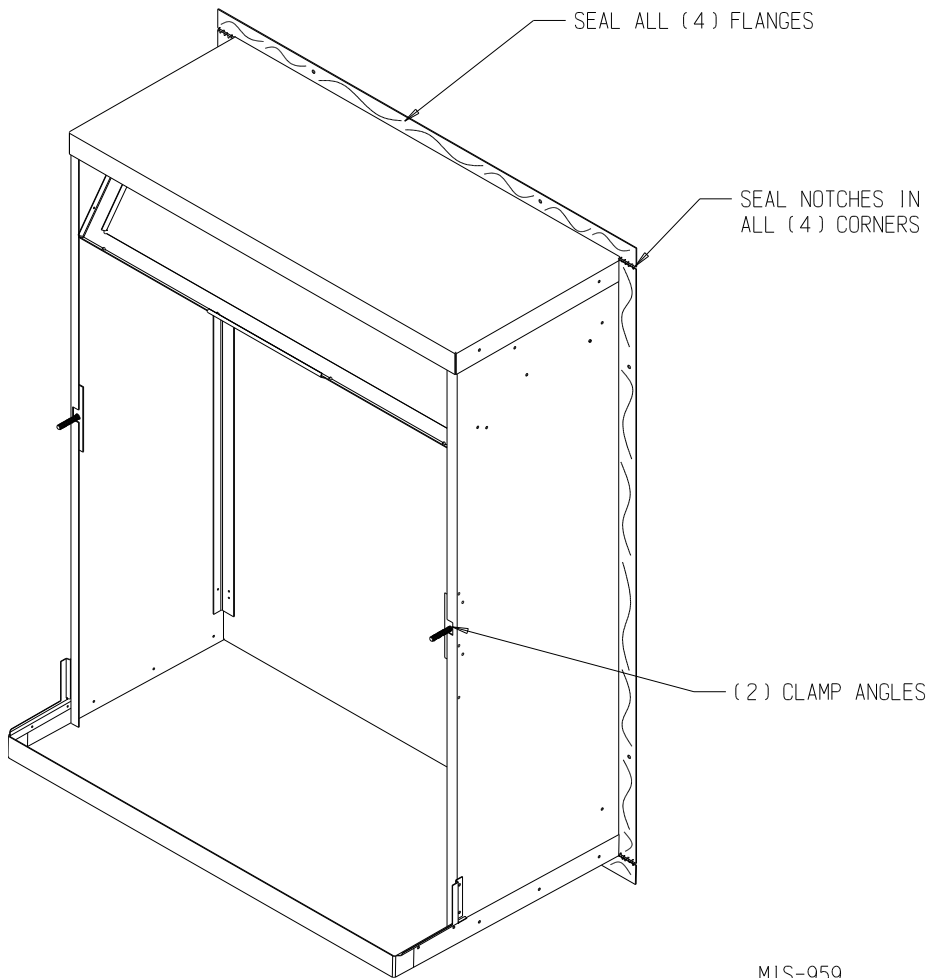

MIS-959

The sleeve is then reinserted into the prepared opening from the outside of the building. All of the mounting flanges must contact the exterior wall. Check to see that there is enough sealant to make this joint watertight. Additional sealant must be applied as necessary. The sleeve must be centered in the opening, and the bottom of the sleeve must be checked to make certain that it is level from side to side. The bottom flange should be be secured to the wall by using two screws through the holes in the bottom mounting flange of the sleeve. The sleeve must be checked to make sure that it is square in the opening. Once the sleeve is square, the side and top mounting flanges of the sleeve must be secured to the wall with screws through the holes in the flanges. The gaps between the side flanges, and the top and bottom flanges must be filled with additional sealant.

On the inside of the building, the gaps between the sleeve and the opening must be filled with insulation. This will help insulate the sleeve and prevent any unwanted outdoor air. See Figure 5.

If the Q-TEC unit will be drained through the wall, the drain line must be installed through the wall. Information for the drain installation is contained in the Q-TEC Installation Instructions.

INSTALLATION – MASONRY CONSTRUCTION WALLS

For masonry construction walls, the dimensions for the opening will be 48 inches tall by 43 inches wide. These dimensions are measured from the finished floor height. See Figure 4. These will be the finish dimensions of the opening.

A 1-1/2 inch spacer needs to be installed in the bottom of the opening to raise the sleeve off the floor. Masonry blocks 1-inch thick, minimum of 6 inches wide, with 1/2 inch mortar between the block and floor will provide the required spacing. These blocks are to be laid flush with the outside wall, and must provide a water tight seal to the floor and to the opening sides. See Figure 2.

The sleeve should be test fit in the opening before final preparations are made. The sleeve will be installed into the opening from the outside of the building in. The sleeve must be centered in the opening from side to side. The mounting flanges of the sleeve must contact the outside wall all around the opening. The side and top mounting flanges must have the mounting holes drilled into the outside wall for the concrete anchors

**FIGURE 4
MASONRY CONSTRUCTION INSTALLATION**

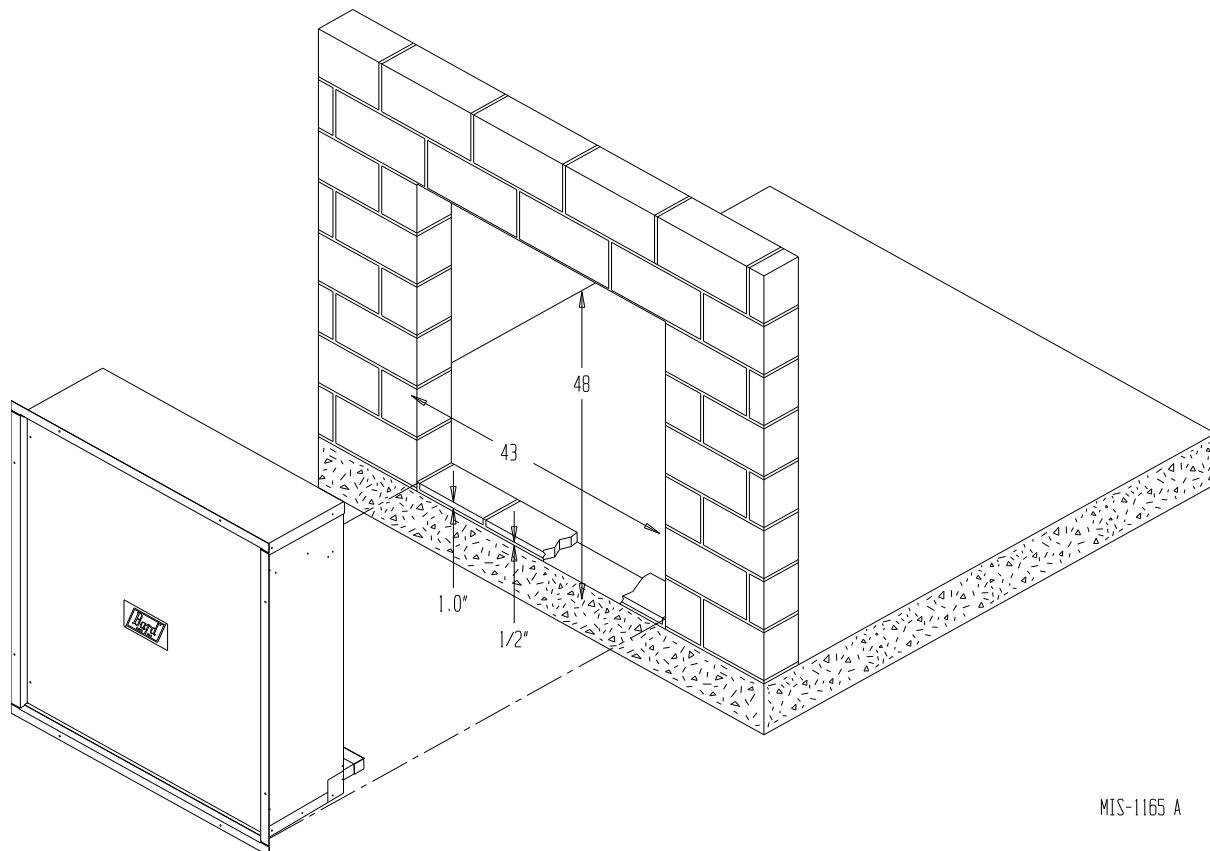

MIS-1165 A

which will hold the sleeve in the wall. The holes should be drilled through the holes in the sleeve with the sleeve level and square in the opening. A slope is built into the bottom of the sleeve from the inside to the outside. This will allow any water that gets into the sleeve to drain out. Once the test fitting has been checked out, the sleeve should be removed from the wall.

With the sleeve removed, two 1/4 inch beads of sealant must be applied to the flanges that contact the outside wall. (See Figure 3.) The sleeve must be installed back in the wall making sure that the predrilled holes in the wall line up with the holes in the mounting flanges of the sleeve. Check to make sure that there is enough sealant between the wall and the flanges to make the joint water tight. Additional sealant must be applied as

required.

The sleeve must be anchored to the wall. All four mounting flanges must be fastened with two fasteners each to the outside wall. The gaps between the side flanges, and the top and bottom flanges must be sealed to the wall.

On the inside of the building, the gaps between the sleeve and the opening must be filled with insulation. This will help insulate the sleeve and prevent infiltration of any unwanted outdoor air. See Figure 5.

If the Q-TEC unit will be drained through the wall, the drain line must be installed through the wall. Information for the drain installation is contained in the Q-TEC Installation Instructions.

**FIGURE 5
TYPICAL INSTALLATION WITH 14" MAX. WALL THICKNESS**

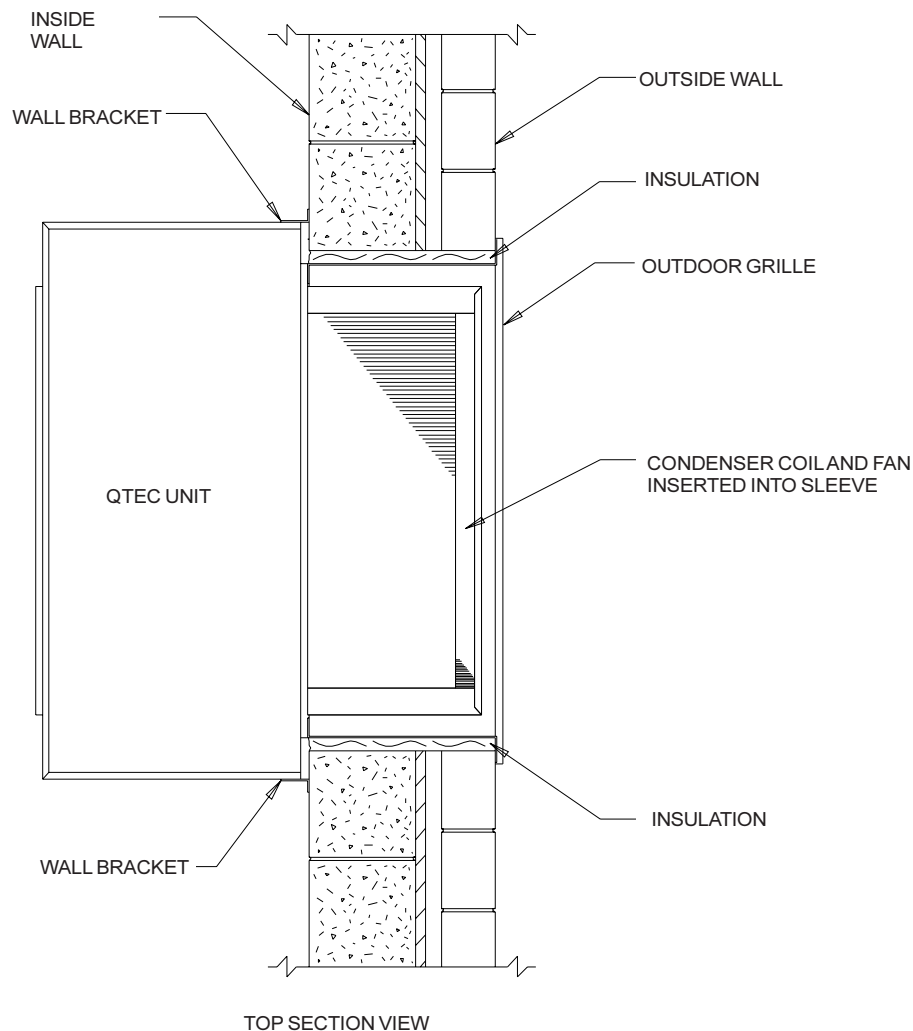

ACCESSORY ITEMS

The QCDS48A is a condensate disposal system for use on all Q-TEC air-source equipment. The system consists of a drain box that attaches to the side of the wall sleeve. It has a rear drain that the installer connects a field supplied drain tube that will exit the exterior wall adjacent to the wall sleeve. It also includes a provision to connect the indoor drain tube to bypass the condensate from having to travel through the outdoor drain pan.

Bypassing the outdoor drain pan with the indoor condensate can benefit the installation in regards to reducing growth within the lower pan by prohibiting standing water during the warm cooling season.

The rear drain box gives further benefit as it allows the Q-TEC unit to be installed or removed without connecting or disconnecting the drain line.

The installation of the QCDS48A requires a recessed area next to the sleeve being built. See Figure 6 for dimensions of the recess for the drain box.

A heated version of the drain box (QCDS48H) is also available for application in climates where concern of freezing may occur. It includes the rear drain tube that projects through the exterior wall. It includes a self-regulating heater box interior of the drain box and on the outlet tube that connects to a 115 Volt power supply.

**FIGURE 6
QCDS48A CONDENSATE DISPOSAL SYSTEM**

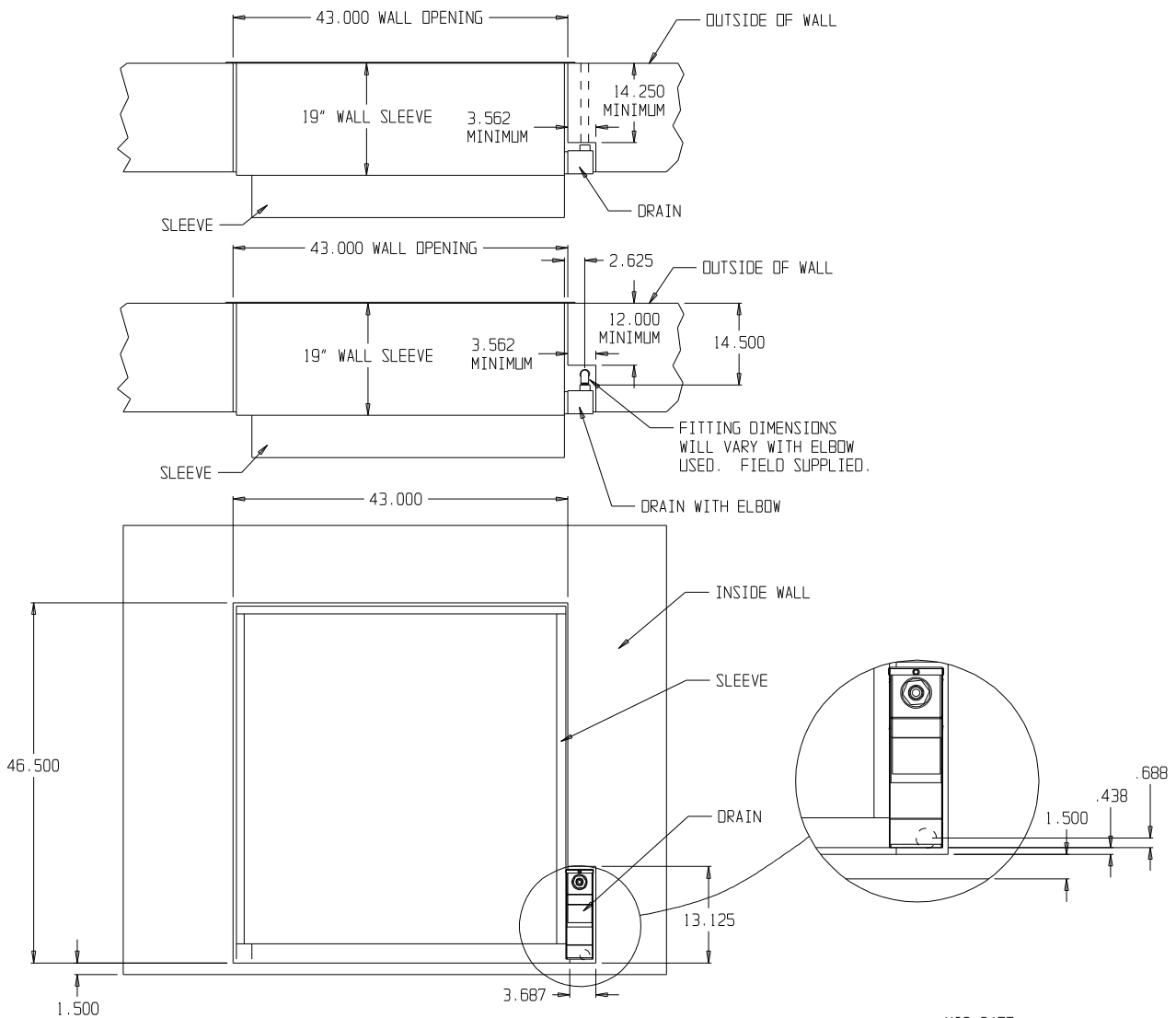

MIS-2475

ATTACHMENT OF WALL SLEEVE TO Q-TEC UNIT

Wall sleeve models QWS48A-H19 has two methods of attachment. It can be attached to the Q-TEC units with brackets supplied with the unit. The side brackets are screwed to the sleeve side and unit side with six screws per side. This method can be used if adequate clearance is available on each side of the unit to drive the screws. If this method is to be used the studs attached to sleeve must be removed and discarded.

The other installation method is for installations where there is not adequate clearance to drive the screw into the cabinet sides. The attachment can be made from inside of the unit. There are two threaded studs extending from the room side of the sleeve to matching holes in the unit rear panel, and are secured with 5/16 nut on each side. See Figure 3.

To use this method, discard the two side mounting brackets. Remove the nuts and washers from the threaded studs and retain for use later. Remove the lower cabinet door and locate the mating holes in the rear of the cabinet. It may be necessary to clear the holes of gasket material.

Roll unit into place making sure the unit is aligned from side to side and that studs have entered the holes in the cabinet back. Push unit back until the rubber seal on the rear of the cabinet touches the flange on the wall sleeve. Replace the washers and nuts previously removed from the studs. Tighten nuts until there is some compression of the gasket. Replace the lower cabinet panel.