INSTALLATION INSTRUCTIONS

WALL MOUNTED PACKAGE HEAT PUMPS

**MODELS:
WH422D
WH484D
WH603D**



CLIMATE CONTROL SOLUTIONS

Bard Manufacturing Company
Bryan, Ohio 43506

Since 1914...Moving ahead just as planned.

Manual : 2100-443A
Supersedes: 2100-443
File: Volume III Tab 17
Date: 01-23-04

Contents

Getting Other Informations and Publications

For more information, contact these publishers: 1

Wall Mount General Information

Heat Pump Wall Mount Model Nomenclature 2
Shipping Damage 5
General 5
Duct Work 5
Filters 5
Fresh Air Intake 6
Condensate Drain 6

Installation Instructions

Wall Mounting Information 7
Mounting the Unit 7
Typical Installations 7
Wiring – Main Power 11
Wiring – Low Voltage 11
Low Voltage Connections 11
Units Equipped with 1F93-380 Thermostat 14
Units Equipped with T8511 Thermostat 14

Figures

Figure 1 Unit Dimensions 3
Figure 2 Blower Damper Assembly 6
Figure 3 Mounting Instructions 8
Figure 4 Electric Heat Clearance 8
Figure 5 Wall Mounting Instructions 9
Figure 6 Wall Mounting Instructions 9
Figure 7 Common Wall Mounting Installations 10
Figure 8 Hot Gas Reheat During
Dehumidification with CS2000 12
Figure 9 Hot Gas Reheat During
Dehumidification with
Programmable Thermostat 13
Figure 10 Start Up Label 15
Figure 11 Defrost Control Board 18
Figure 12 Fan Blade Setting 21
Figure 13 Circuit Diagram Heat Pump
Cooling Mode 24
Figure 14 Circuit Diagram Heat Pump
Dehumidification Mode 24

Start Up

Important Installer Note 15
Crankcase Heaters 15
High Pressure Switch 15
Three Phase Scroll Compressor Start Up 15
Phase Monitor 16
Service Hints 16
Sequence of Operation 16
Pressure Service Ports 16
Defrost Cycle 17

Troubleshooting

Solid State Heat Pump Control
Troubleshooting Procedure 18
Checking Temperature Sensor
Outside Unit Circuit 19
Temperature vs. Resistance of
Temperature Sensor 19
Fan Blade Dimensions 20
Removal of Fan Shroud 20
Refrigerant Charge 20
Pressure Tables 21-22
Optional Accessories 23

Tables

Table 1 Electric Heat Table 2
Table 2 Electrical Specifications 4
Table 3 Thermostat Wire Size 14
Table 4 Wall Thermostats 14
Table 5 Troubleshooting 18
Table 6 Fan Blade Dimensions 20
Table 7 Suction Line Temperatures 20
Table 8 Recommended Operating Ranges 20
Table 9 Indoor Blower Performance 20
Table 10 Maximum ESP of Operation 21
Table 11 Pressure Table – Cooling 21
Table 12 Pressure Table – Heating 22
Table 13 Optional Accessories 22
Table 14 Dehumidification Relay Logic Board 23

Getting Other Information and Publications

These publications can help you install the air conditioner or heat pump. You can usually find these at your local library or purchase them directly from the publisher. Be sure to consult current edition of each standard.

National Electrical Code ANSI/NFPA 70

Standard for the Installation ANSI/NFPA 90A
of Air Conditioning and
Ventilating Systems

Standard for Warm Air ANSI/NFPA 90B
Heating and Air
Conditioning Systems

Load Calculation for ACCA Manual J or N
Residential Winter and
Summer Air Conditioning

Low Pressure, Low Velocity ACCA Manual D or Q
Duct System Design for Winter
and Summer Air Conditioning

For more information, contact these publishers:

ACCA **Air Conditioning Contractors of America**
1712 New Hampshire Ave. N.W.
Washington, DC 20009
Telephone: (202) 483-9370
Fax: (202) 234-4721

ANSI **American National Standards Institute**
11 West Street, 13th Floor
New York, NY 10036
Telephone: (212) 642-4900
Fax: (212) 302-1286

ASHRAE **American Society of Heating Refrigerating
and Air Conditioning Engineers, Inc.**
1791 Tullie Circle, N.E.
Atlanta, GA 30329-2305
Telephone: (404) 636-8400
Fax: (404) 321-5478

NFPA **National Fire Protection Association**
Batterymarch Park
P.O. Box 9101
Quincy, MA 02269-9901
Telephone: (800) 344-3555
Fax: (617) 984-7057

Manufactured under the following U.S. patent numbers:
5,301,744; 5,002,116; 4,924,934; 4,875,520; 4,825,936
Other patents pending.

WALL MOUNT GENERAL INFORMATION

Heat Pump Wall Mount Model Nomenclature

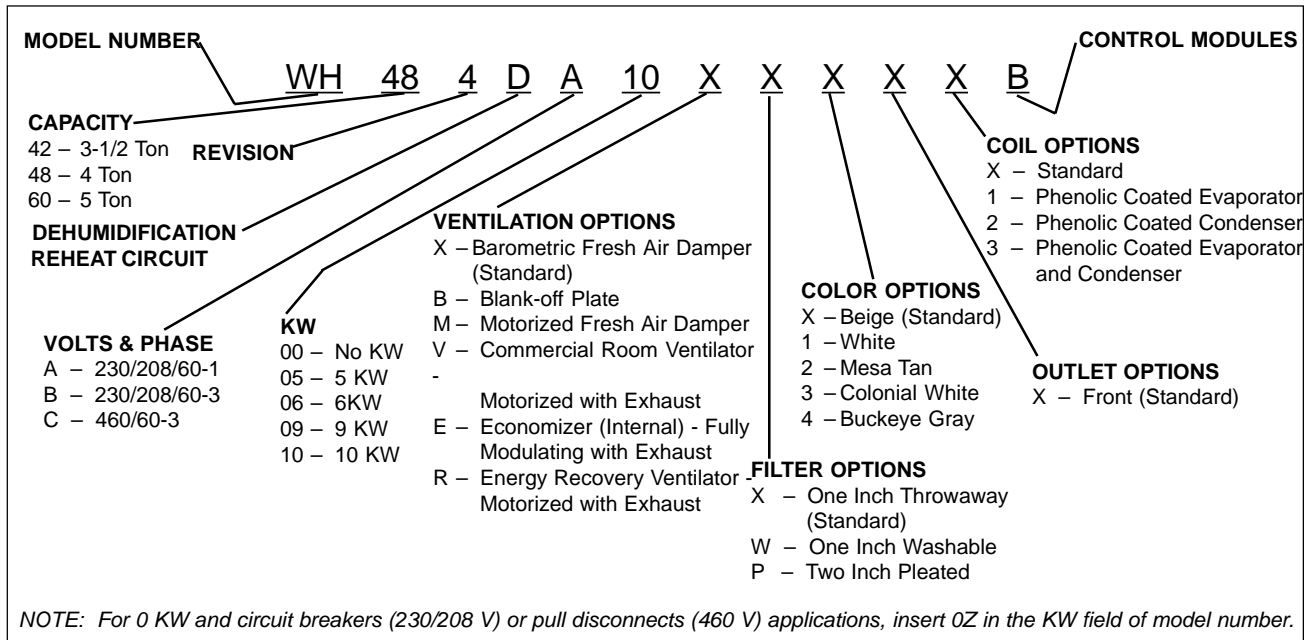
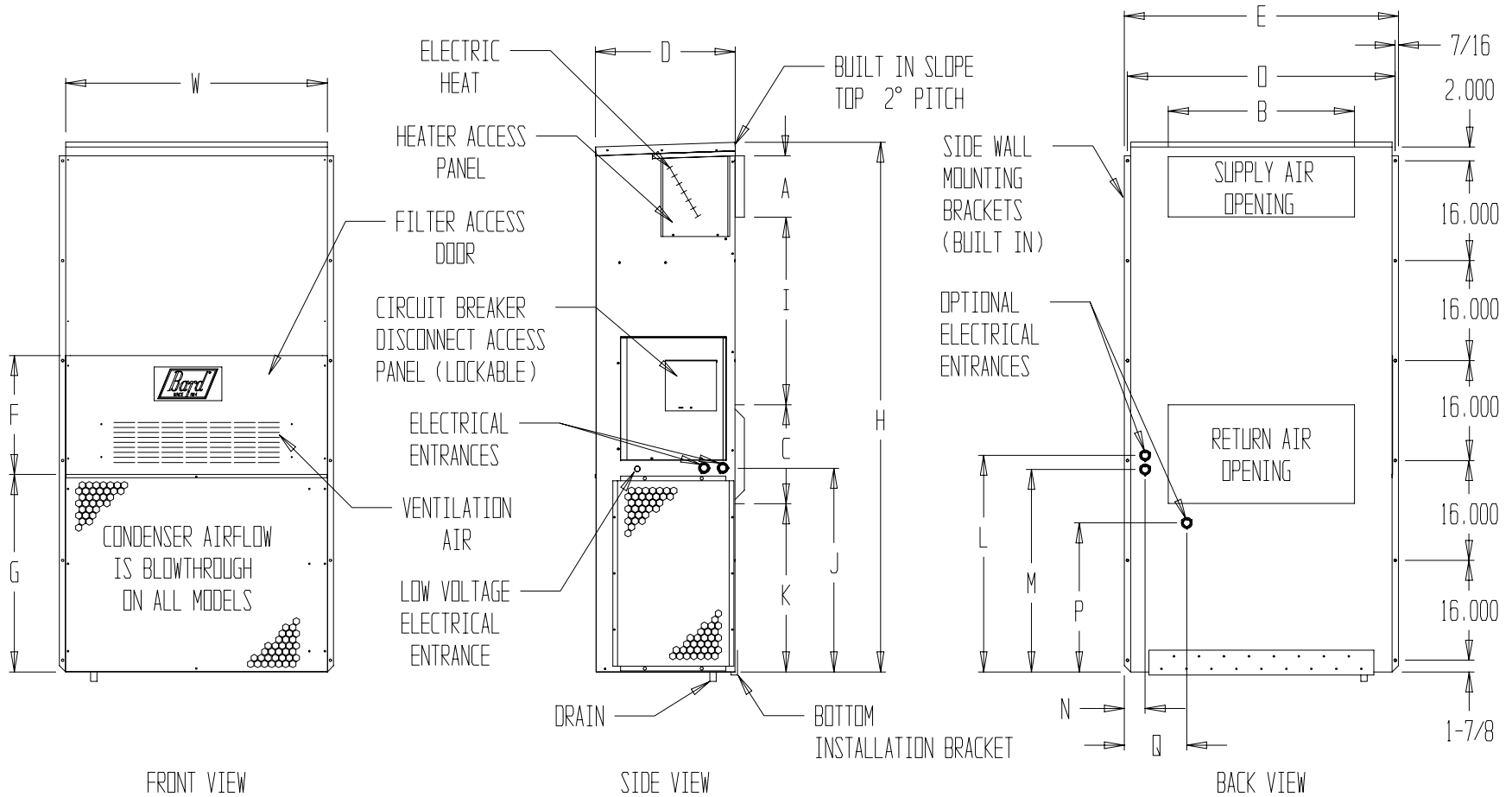

**TABLE 1
ELECTRIC HEAT TABLE**

Models	WH422DA				WH422DB WH484DB				WH422DC				WH484DA WH603DA				WH484DB WH603DB				WH484DC WH603DC	
	240-1		208-1		240-3		208-3		460-3		240-1		208-1		240-3		208-3		460-3			
	A	BTU	A	BTU	A	BTU	A	BTU	A	BTU	A	BTU	A	BTU	A	BTU	A	BTU	A	BTU		
5	20.8	17065	18.1	12800							20.8	17065	18.1	12800								
6					14.4	20500	12.5	15360	7.2	20480												
9					21.7	30600	18.7	23030	10.8	30700					21.7	30600	18.7	23030	10.8	30700		
10	41.6	34130	36.2	25600							41.6	34130	36.2	25600								

**FIGURE 1
UNIT DIMENSIONS**

UNIT	WIDTH (W)	DEPTH (D)	HEIGHT (H)	SUPPLY		RETURN		E	F	G	I	J	K	L	M	N	O	P	Q
				A	B	C	B												
42-48-60	42	22-1/4	84-7/8	9-7/8	29-7/8	15-7/8	29-7/8	43-7/8	19	31-5/8	30	32-11/16	27	34-3/4	32-1/2	3-1/4	43	23-7/8	10



**TABLE 2
ELECTRICAL SPECIFICATIONS**

Model	SINGLE CIRCUIT						DUAL CIRCUIT							
	Rated Volts & Phase	No. Field Power Ckts.	④	①	②	②	④		①		②		②	
			Minimum Circuit Ampacity	Maximum External Fuse or Circuit Breaker	Field Power Wire Size	Ground Wire Size	Minimum Circuit Ampacity	Maximum External Fuse or Ckt. Breaker	Field Power Wire Size	Ground Wire Size	Ckt A	Ckt B	Ckt A	Ckt B
WH422DA00, A0Z A05 ③ A10	230/208-1	1 1 or 2 1 or 2	34 60 86	50 70 90	8 6 3	10 8 8	N/A 34 34	N/A 26 52	N/A 50 50	N/A 30 60	N/A 8 8	N/A 10 6	N/A 10 10	N/A 10 10
WH422DB00, B0Z B06 ③ B09	230/208-3	1 1 1	26 44 53	35 50 60	8 8 6	10 10 10	N/A N/A N/A	N/A N/A N/A	N/A N/A N/A	N/A N/A N/A	N/A N/A N/A	N/A N/A N/A	N/A N/A N/A	N/A N/A N/A
WH422DC00, C0Z C06 ③ C09	460-3	1 1 1	13 23 27	20 25 30	12 10 10	12 10 10	N/A N/A N/A	N/A N/A N/A	N/A N/A N/A	N/A N/A N/A	N/A N/A N/A	N/A N/A N/A	N/A N/A N/A	N/A N/A N/A
WH484DA00, A0Z A05 ③ A10	230/208-1	1 1 or 2 1 or 2	38 64 90	50 80 100	8 6 3	10 8 8	N/A 38 38	N/A 26 52	N/A 60 60	N/A 30 60	N/A 8 8	N/A 10 6	N/A 10 10	N/A 10 10
WH484DB00, B0Z B06 ③ B09	230/208-3	1 1 1	27 45 54	35 50 60	8 8 6	10 10 10	N/A N/A N/A	N/A N/A N/A	N/A N/A N/A	N/A N/A N/A	N/A N/A N/A	N/A N/A N/A	N/A N/A N/A	N/A N/A N/A
WH484DC00, C0Z ③ C09	460-3	1 1	15 28	20 30	12 10	12 10	N/A N/A	N/A N/A	N/A N/A	N/A N/A	N/A N/A	N/A N/A	N/A N/A	N/A N/A
WH603DA00, A0Z A05 ③ A10	230/208-1	1 1 or 2 1 or 2	45 71 97	60 90 110	8 4 3	10 8 6	N/A 45 45	N/A 26 52	N/A 60 60	N/A 60 60	N/A 8 8	N/A 10 6	N/A 10 10	N/A 10 10
WH603DB00, B0Z ③ B09	230/208-3	1 1	33 60	45 60	8 6	10 10	N/A N/A	N/A N/A	N/A N/A	N/A N/A	N/A N/A	N/A N/A	N/A N/A	N/A N/A
WH603DC00, C0Z ③ C09	460	1 1	16 29	20 35	12 8	12 10	N/A N/A	N/A N/A	N/A N/A	N/A N/A	N/A N/A	N/A N/A	N/A N/A	N/A N/A

- ① Maximum size of the time delay fuse or HACR type circuit breaker for protection of field wiring conductors.
- ② Based on 75°C copper wire. All wiring must conform to NEC and all local codes.
- ③ Maximum KW that can operate with heat pump on.
- ④ These Minimum Circuit Ampacity" values are to be used for sizing the field power conductors. Refer to the National Electrical Code (latest version), article 310 for power conductor sizing. **CAUTION: When more than one field power conductor circuit is run through one conduit, the conductors must be derated. Pay special attention to note 8 of table 310 regarding Ampacity Adjustment Factors when more than 3 conductors are in a raceway.**

SHIPPING DAMAGE

Upon receipt of equipment, the carton should be checked for external signs of shipping damage. If damage is found, the receiving party must contact the last carrier immediately, preferably in writing, requesting inspection by the carrier's agent.

GENERAL

The equipment covered in this manual is to be installed by trained, experienced service and installation technicians.

The refrigerant system is completely assembled and charged. All internal wiring is complete.

The unit is designed for use with or without duct work. Flanges are provided for attaching the supply and return ducts.

These instructions and any instructions packaged with any separate equipment required to make up the entire heat pump system should be carefully read before beginning the installation. Note particularly "Starting Procedure" and any tags and/or labels attached to the equipment.

While these instructions are intended as a general recommended guide, they do not supersede any national and/or local codes in any way. Authorities having jurisdiction should be consulted before the installation is made. See Page 1 for information on codes and standards.

Size of unit for a proposed installation should be based on heat loss calculation made according to methods of Air Conditioning Contractors of America (ACCA). The air duct should be installed in accordance with the Standards of the National Fire Protection Association for the Installation of Air Conditioning and Ventilating Systems of Other Than Residence Type, NFPA No. 90A, and Residence Type Warm Air Heating and Air Conditioning Systems, NFPA No. 90B. Where local regulations are at a variance with instructions, installer should adhere to local codes.

DUCT WORK

Any heat pump is more critical of proper operating charge and an adequate duct system than a straight air conditioning unit. All duct work, supply and return, must be properly sized for the design air flow requirement of the equipment. Air Conditioning Contractors of America (ACCA) is an excellent guide to proper sizing. All duct work or portions thereof not in the conditioned space should be properly insulated in order to both conserve energy and prevent condensation or moisture damage.

Refer to Table 10 for maximum static pressure available for duct design.

Design the duct work according to methods given by the Air Conditioning Contractors of America (ACCA). When duct runs through unheated spaces, it should be insulated with a minimum of one inch of insulation. Use insulation with a vapor barrier on the outside of the insulation. Flexible joints should be used to connect the duct work to the equipment in order to keep the noise transmission to a minimum.

A 1/4 inch clearance to combustible material for the first three feet (3') of duct attached to the outlet air frame is required. See Wall Mounting Instructions and Figures 4 and 5 for further details.

Ducts through the walls must be insulated and all joints taped or sealed to prevent air or moisture entering the wall cavity.

CAUTION

Some installations may not require any return air duct. A metallic return air grille is required with installations not requiring a return air duct. The spacing between louvers on the grille shall not be larger than 5/8 inches.

Any grille that meets the 5/8 inch louver criteria, may be used. It is recommended that Bard Return Air Grille Kit RG-2 thru RG-5 or RFG-2 thru RFG-5 be installed when no return duct is used. Contact distributor or factory for ordering information. If using a return air filter grille, filters must be of sufficient size to allow a maximum velocity of 400 fpm.

NOTE: If no return air duct is used, applicable installation codes may limit this cabinet to installation only in a single story structure.

FILTERS

A 1 inch throwaway filter is supplied with each unit. The filter slides into position making it easy to service. This filter can be serviced from the outside by removing the service door. A 1 inch washable filter and 2 inch pleated filter are also available as optional accessories. The internal filter brackets are adjustable to accommodate the 2 inch filter by bending down the tabs to allow spacing for the 2 inch filters.

FRESH AIR INTAKE

All units are built with fresh air inlet slots punched in the service panel.

If the unit is equipped with the fresh air damper assembly, the assembly is shipped already attached to the unit. The damper blade is locked in the closed position. To allow the damper to operate, the maximum and minimum blade position stops must be installed. See Figure 1.

All capacity, efficiency and cost of operation information as required for Department of Energy "Energyguide" Fact Sheets is based upon the fresh air blank-off plate in place and is recommended for maximum energy efficiency.

The blank-off plate is available upon request from the factory and is installed in place of the fresh air damper shipped with each unit.

CONDENSATE DRAIN

A plastic drain hose extends from the drain pan at the top of the unit down to the unit base. There are openings in the unit base for the drain hose to pass through. In the event the drain hose is connected to a drain system of some type, it must be an open or vented type system to assure proper drainage.

**FIGURE 2
BLOWER DAMPER ASSEMBLY**

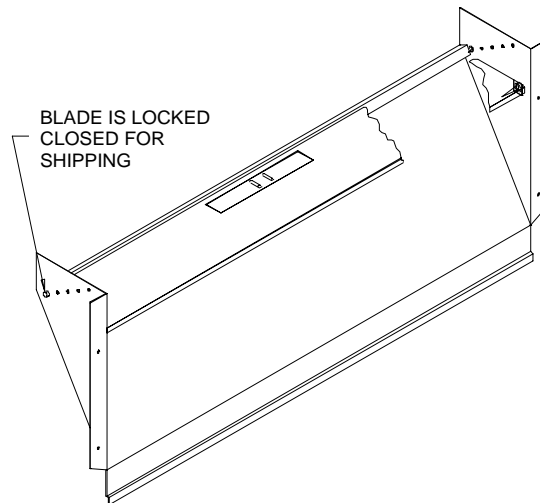

MIS-938

INSTALLATION INSTRUCTIONS

WALL MOUNTING INFORMATION

1. Two holes, for the supply and return air openings, must be cut through the wall as shown in Figure 3.
2. On wood-frame walls, the wall construction must be strong and rigid enough to carry the weight of the unit without transmitting any unit vibration. See Figures 4 and 5.

WARNING

Fire hazard can result if 1/4 inch clearance to combustible materials for supply air duct is not maintained. See Figure 3.

3. Concrete block walls must be thoroughly inspected to insure that they are capable of carrying the weight of the installing unit. See Figure 4.

MOUNTING THE UNIT

1. These units are secured by wall mounting brackets which secure the unit to the outside wall surface at both sides. A bottom mounting bracket is provided for ease of installation, but it is not required.
2. The unit itself is suitable for "0" inch clearance, but the supply air duct flange and the first 3 feet of supply air duct require a minimum of 1/4 inch clearance to combustible material. If a combustible wall, use a minimum of 30-1/2" x 10-1/2" dimensions for sizing. However, it is generally recommended that a 1 inch clearance is used for ease of installation and maintaining the required clearance to combustible material. The supply air opening would then be 32" x 12". See Figures 2, 4 and 7 for details.

WARNING

Failure to provide the 1/4 inch clearance between the supply duct and a combustible surface for the first 3 feet of duct can result in fire.

3. Locate and mark lag bolt locations and bottom mounting bracket location. See Figure 4.
4. Mount bottom mounting bracket.
5. Hook top rain flashing under back bend of top. Top rain flashing is shipped secured to the right side of the back.
6. Position unit in opening and secure with 5/16 lag bolts; use 7/8 inch diameter flat washers on the lag bolts.
7. Secure rain flashing to wall and caulk across entire length of top. See Figure 2.
8. For additional mounting rigidity, the return air and supply air frames or collars can be drilled and screwed or welded to the structural wall itself (depending upon wall construction). Be sure to observe required clearance if combustible wall.
9. On side by side installations, maintain a minimum of 20 inches clearance on right side to allow access to heat strips and control panel, and to allow proper airflow to the outdoor coil. Additional clearance may be required to meet local or national codes.

TYPICAL INSTALLATIONS

See Figure 6 for common ways to install the wall-mount unit.

**FIGURE 3
MOUNTING INSTRUCTIONS**

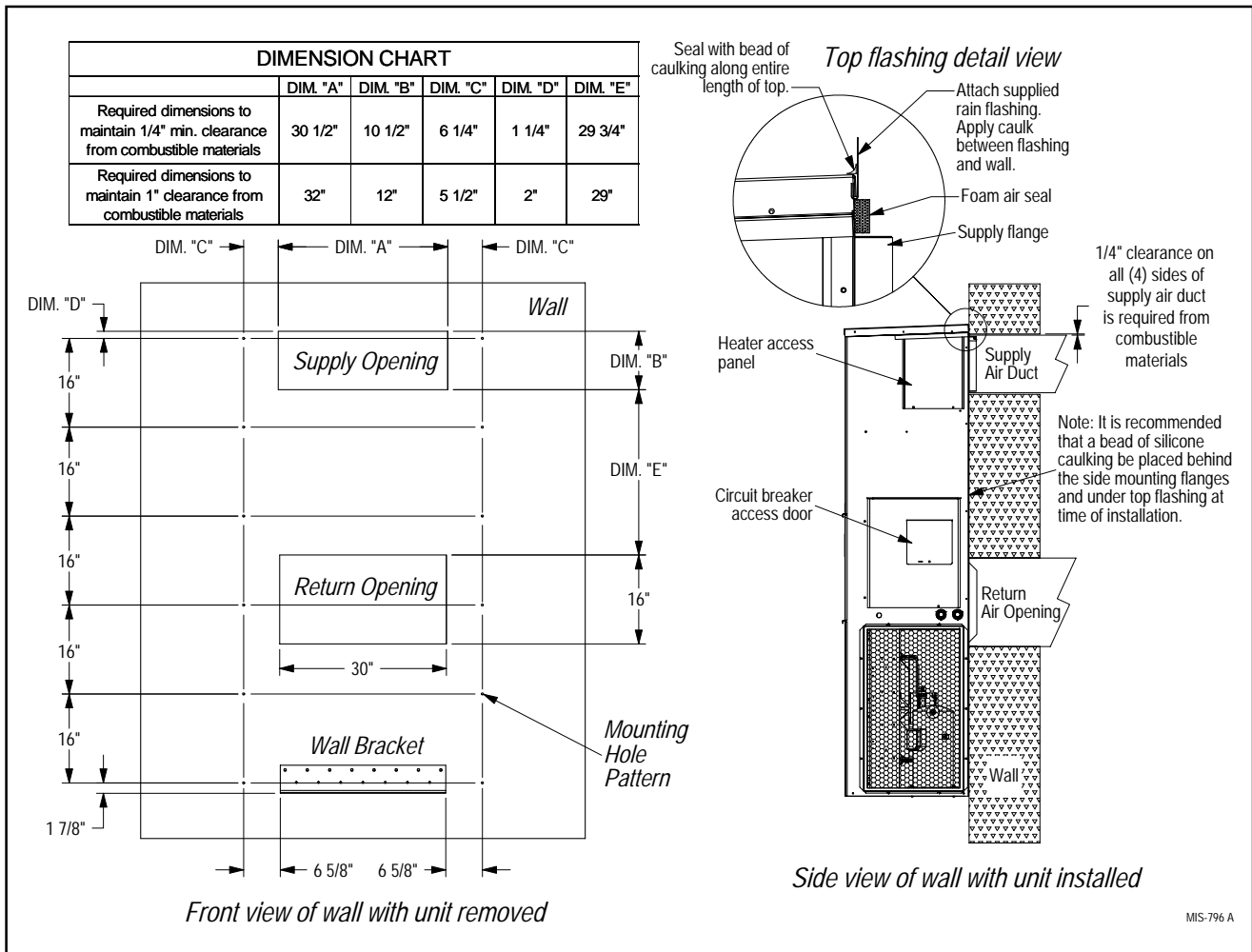

**FIGURE 4
ELECTRIC HEAT CLEARANCE**

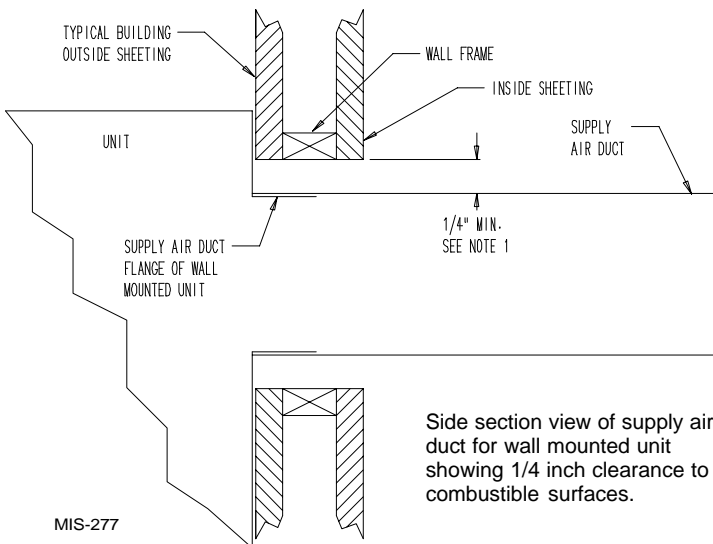

⚠ WARNING

- A minimum of 1/4 inch clearance must be maintained between the supply air duct and combustible materials. This is required for the first 3 feet of ducting.
- It is important to insure that the 1/4 inch minimum spacing is maintained at all points.
- Failure to do this could result in overheating the combustible material and may result in fire.

FIGURE 5 WALL-MOUNTING INSTRUCTIONS

SEE FIGURE 3 — MOUNTING INSTRUCTIONS

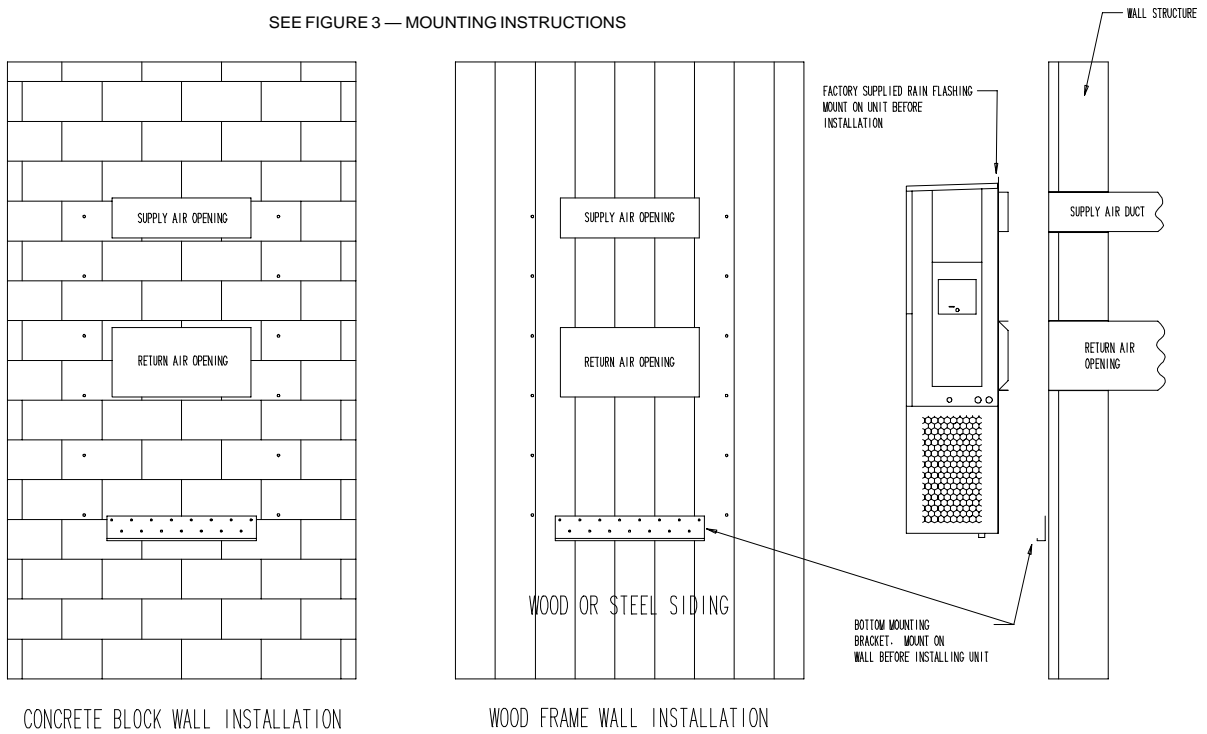

MIS-548

FIGURE 6 WALL-MOUNTING INSTRUCTIONS

SEE UNIT DIMENSIONS, FIGURE 1,
FOR ACTUAL DIMENSIONS

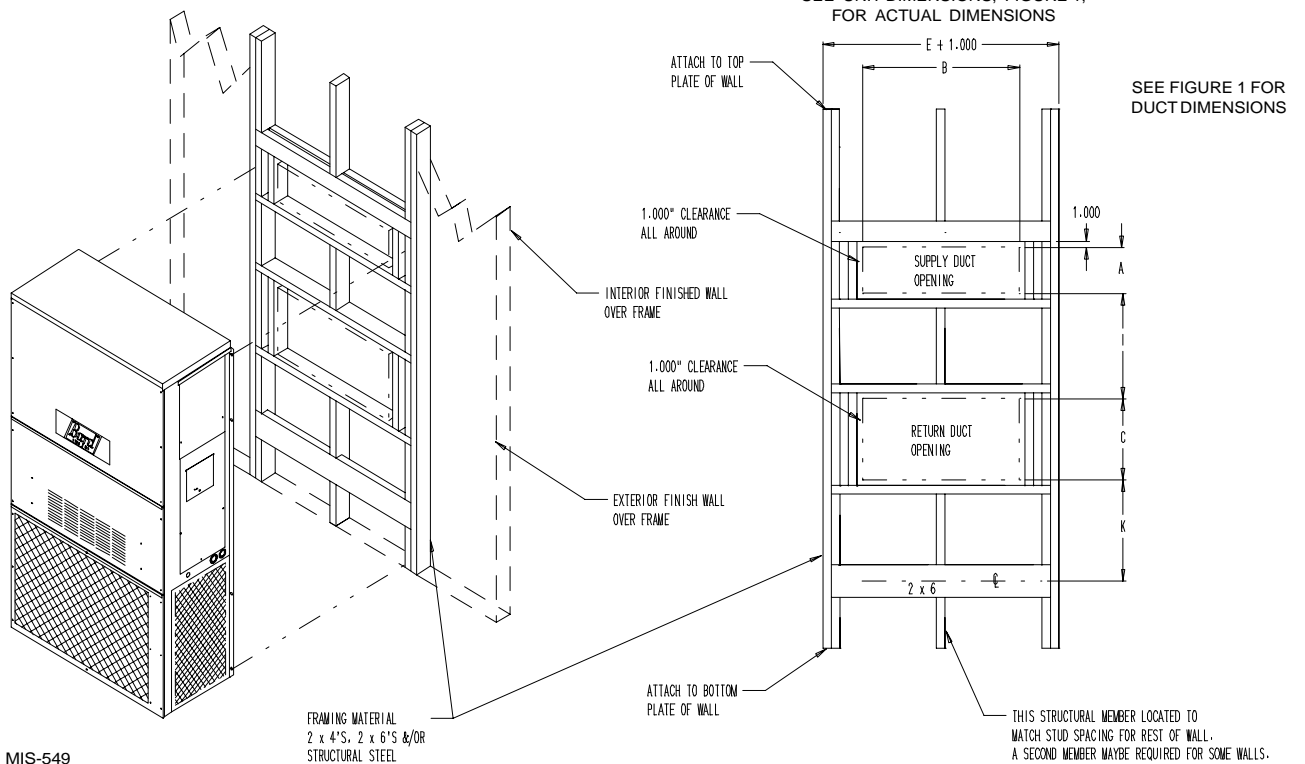

MIS-549

**FIGURE 7
COMMON WALL-MOUNTING INSTALLATIONS**

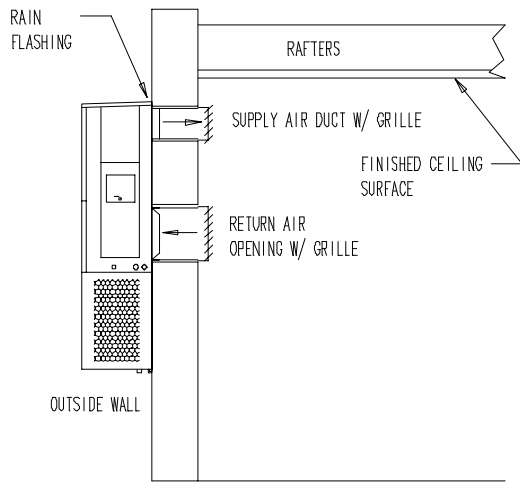

FREE AIR FLOW
NO DUCT

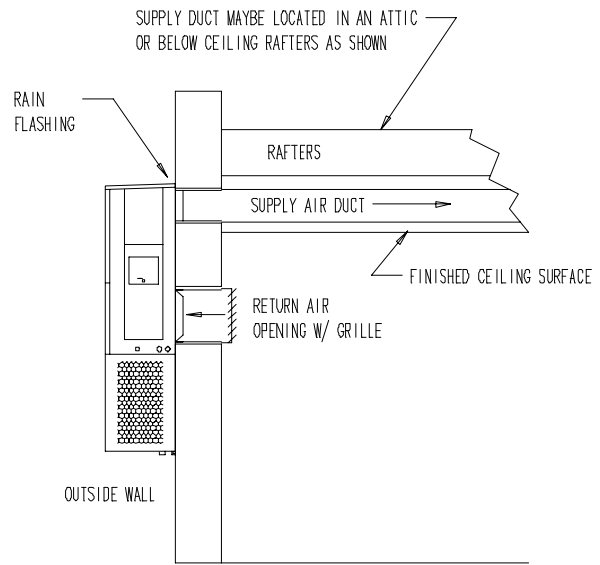

DUCTED SUPPLY
RETURN AT UNIT

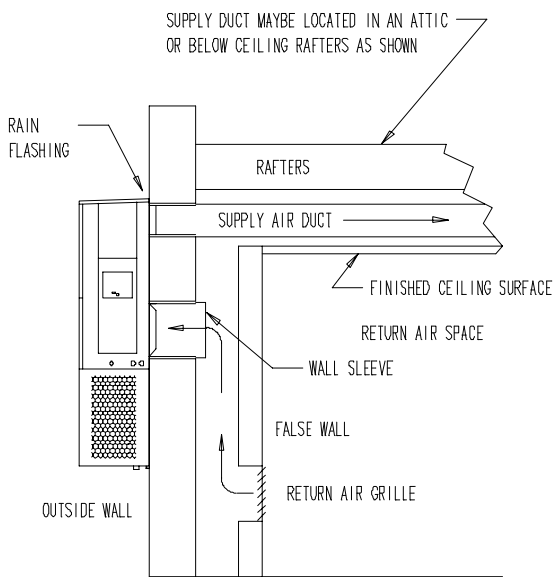

FALSE WALL INSTALLATION

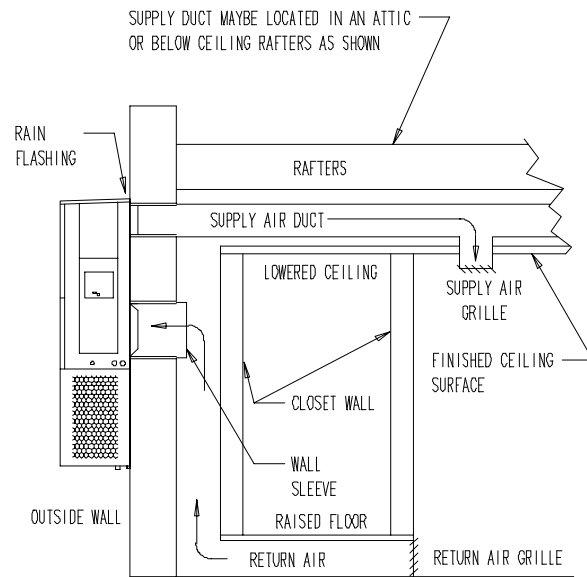

CLOSET INSALLATION

WIRING — MAIN POWER

Refer to the unit rating plate for wire sizing information and maximum fuse or “HACR” type circuit breaker size. Each outdoor unit is marked with a “Minimum Circuit Ampacity”. This means that the field wiring used must be sized to carry that amount of current. Depending on the installed KW of electric heat, there may be two field power circuits required. If this is the case, the unit serial plate will so indicate. All models are suitable only for connection with copper wire. Each unit and/or wiring diagram will be marked “Use Copper Conductors Only”. These instructions **must be** adhered to. Refer to the National Electrical Code (NEC) for complete current carrying capacity data on the various insulation grades of wiring material. All wiring must conform to NEC and all local codes.

The electrical data lists fuse and wire sizes (75°C copper) for all models, including the most commonly used heater sizes. Also shown are the number of field power circuits required for the various models with heaters.

The unit rating plate lists a “Maximum Time Delay Relay Fuse” or “HACR” type circuit breaker that is to be used with the equipment. The correct size must be used for proper circuit protection and also to assure that there will be no nuisance tripping due to the momentary high starting current of the compressor motor.

The disconnect access door on this unit may be locked to prevent unauthorized access to the disconnect. To convert for the locking capability, bend the tab located in the bottom left hand corner of the disconnect opening under the disconnect access panel straight out. This tab will now line up with the slot in the door. When shut, a padlock may be placed through the hole in the tab preventing entry.

See Start-up section for information on three phase scroll compressor start-ups.

WIRING — LOW VOLTAGE WIRING

230/208V, 1 phase and 3 phase equipment dual primary voltage transformers. All equipment leaves the factory wired on 240V tap. For 208V operation, reconnect from 240V to 208V tap. The acceptable operating voltage range for the 240 and 208V taps are:

Tap	Range
240	253 - 216
208	220 - 197

NOTE: *The voltage should be measured at the field power connection point in the unit and while the unit is operating at full load (maximum amperage operating condition).*

LOW VOLTAGE CONNECTIONS

These units use a grounded 24 volt AC low voltage circuit.

The “R” terminal is the *hot* terminal and the “C” terminal is *grounded*.

“G” terminal is the *fan input*.

“Y” terminal is the *compressor input*.

“B” terminal is the *reversing valve input*. The reversing valve must be energized for heating mode.

“R” terminal is *24 VAC hot*.

“C” terminal is *24 VAC grounded*.

“L” terminal is *compressor lockout output*. This terminal is activated on a high or low pressure trip by the electronic heat pump control. This is a 24 VAC output.

“W2” terminal is *second stage heat* (if equipped).

“O1” terminal is the *ventilation input*. This terminal energizes any factory installed ventilation option.

“E” terminal is the *emergency heat input*. This terminal energizes the emergency heat relay.

“W3” terminal is the *dehumidification input*. This terminal energizes compressor, blower and three-way valve.

NOTE: *For total and proper control using DDC, a total of 7 controlled outputs are required (6 if no ventilation system is installed). For proper system operation under Emergency Heat conditions where the compressor needs to be deactivated, the B-W2-E outputs need to be energized. Removing the Y (compressor) signal alone turns the compressor off, but does not activate the additional circuitry embedded in the heat pump for proper and complete operation.*

LOW VOLTAGE CONNECTIONS FOR DDC CONTROL

Fan Only	Energize G
Cooling Mode	Energize Y, G
Heat Pump Heating	Energize Y, G, B
2nd Stg Heating w/Heat Pump (if employed)	Energize G, W2, Y, B
Ventilation	Energize G, O1
Emergency Heat	Energize B, W2, E, G
Dehumidification	Energize W3

**FIGURE 8
WHXXDX – HOT GAS REHEAT DURING DEHUMIDIFICATION
WITH CS2000 ENERGY MONITOR FULL TIME DEHUMIDIFICATION**

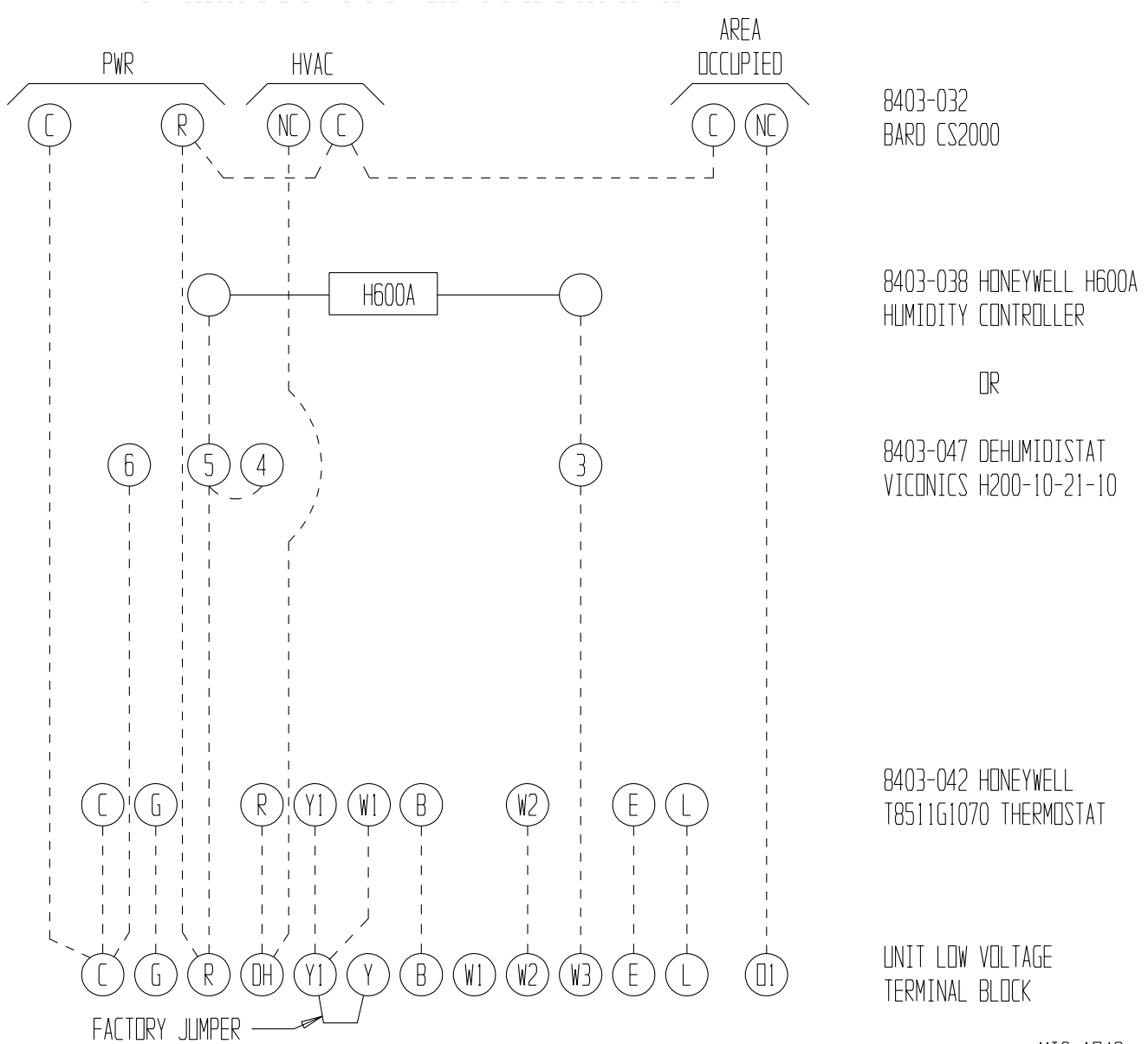

MIS-1746

IMPORTANT NOTE:

*Only the thermostat and subbase combinations as shown in Table 4 will work with this equipment. The thermostat and subbase **must** be matched and the correct operation can be assured only by proper selection and application of these parts.*

FIGURE 9
WHXXXDX – HOT GAS REHEAT DURING DEHUMIDIFICATION
WITH PROGRAMMABLE THERMOSTAT FULL TIME DEHUMIDIFICATION

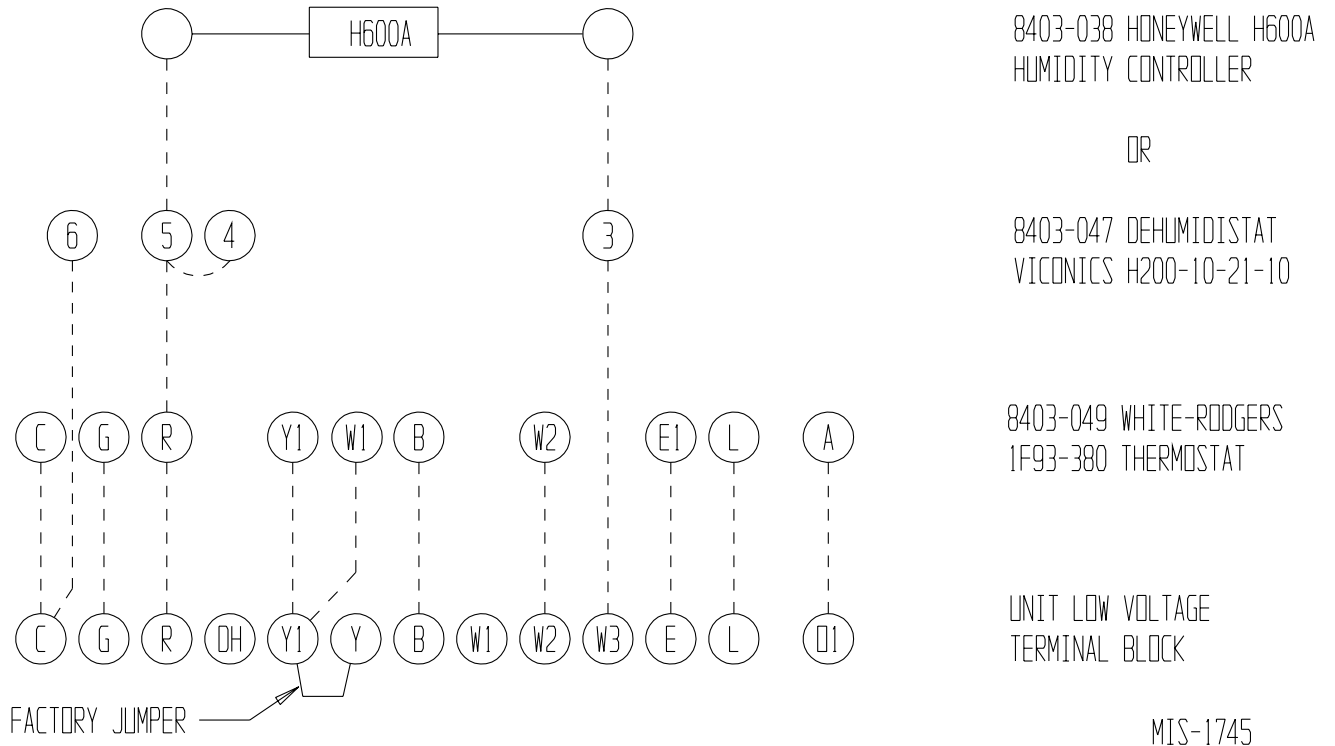

IMPORTANT NOTE:

*Only the thermostat and subbase combinations as shown in Table 4 will work with this equipment. The thermostat and subbase **must** be matched, and the correct operation can be assured only by proper selection and application of these parts.*

**TABLE 3
THERMOSTAT WIRE SIZE**

Transformer VA	FLA	Wire Gauge	Maximum Distance In Feet
55	2.3	20 gauge	45
		18 gauge	60
		16 gauge	100
		14 gauge	160
		12 gauge	250

**TABLE 4
WALL THERMOSTATS**

Thermostat	Predominant Features
8403-042 (T8511G1070)	1 stage cool; 2 stage heat Electronic Non-Programmable Auto or Manual changeover
8403-049 1F93-380	2 stage cool; 3 stage heat 7 Day Programmable Auto or Manual Changeover

IMPORTANT

Only the thermostat and subbase combination as shown in this manual are assured by Bard to work with this equipment.

The thermostat and subbase must be matched, and the correct operation can be assured only by proper selection and application of these parts.

FOR UNITS EQUIPPED WITH 1F93-380 THERMOSTAT (8403-049)

THERMOSTAT INDICATOR LAMPS

The LED comes on and stays on whenever the system switch is placed in the emergency heat position. The LED will flash red if there is any problem that prevents the compressor from running when it is supposed to be.

EMERGENCY HEAT POSITION

The operator of the equipment must manually place the system switch in this position. This is done when there is a known problem with the unit, or when the red flashing LED comes on indicating a problem.

COMPRESSOR MALFUNCTION LIGHT

Actuation of the flashing red LED is accomplished by a relay output from the heat pump control board which is factory installed. Any condition such as loss of charge, high head pressure, etc., that will prevent compressor from operating will cause the red LED to flash. This is a signal to the operator of the equipment to place system in emergency heat position.

FOR UNITS EQUIPPED WITH T8511 THERMOSTAT (8403-042)

THERMOSTAT INDICATOR LAMPS

The red LED will come on if there is any problem that prevents the compressor from running when it is supposed to be.

EMERGENCY HEAT POSITION

The operator of the equipment must manually place the system switch in this position. This is done when there is a known problem with the unit, or when the red LED comes on indicating a problem.

COMPRESSOR MALFUNCTION LIGHT

Actuation of the red LED is accomplished by a relay output from the heat pump control board which is factory installed. Any condition such as loss of charge, high head pressure, etc., that will prevent compressor from operating will cause the red LED to come on. This is a signal to the operator of the equipment to place system in emergency heat position.

IMPORTANT INSTALLER NOTE

For improved start-up performance, wash the indoor coil with a dishwashing detergent.

CRANKCASE HEATERS

WH422 units are provided with compressor crankcase heat. WH484 and WH603 units are not provided with crankcase heat. These units utilize scroll compressors which do not require crankcase heat in this application.

The WH422 models have an insertion well-type heater located in the lower section of the compressor housing this is a self-regulating type heater that draws only enough power to maintain the compressor at a safe temperature on these units.

Some form of crankcase heat is essential to prevent liquid refrigerant from migrating to the compressor, causing oil pump out on compressor start-up and possible valve failure due to compressing a liquid.

The decal in Figure 10 is affixed to all WH422 units detailing start-up procedure. This is very important. *Please read carefully.*

HIGH PRESSURE SWITCH

The models are supplied with a remote reset high pressure switch. If tripped, this pressure switch may be reset by turning the thermostat off then back on again.

THREE PHASE SCROLL COMPRESSOR START UP INFORMATION

Scroll compressors, like several other types of compressors, will only compress in one rotational direction. Direction of rotation is not an issue with single phase compressors since they will always start and run in the proper direction.

However, three phase compressors will rotate in either direction depending upon phasing of the power. Since there is a 50-50 chance of connecting power in such a way as to cause rotation in the reverse direction, verification of proper rotation must be made. All three phase scroll units incorporate a phase monitor to ensure proper field wiring. See the "Phase Monitor" on page 15 of this manual.

Verification of *proper rotation* must be made any time a compressor is change or rewired. If improper rotation is corrected at this time there will be no negative impact on the durability of the compressor. However, reverse operation for over one hour may have a negative impact on the bearing due to oil pump out.

**FIGURE 10
START UP LABEL**

IMPORTANT

THESE PROCEDURES MUST BE FOLLOWED AT INITIAL START UP AND AT ANY TIME POWER HAS BEEN REMOVED FOR 12 HOURS OR LONGER.

TO PREVENT COMPRESSOR DAMAGE WHICH MAY RESULT FROM THE PRESENCE OF LIQUID REFRIGERANT IN THE COMPRESSOR CRANKCASE:

1. MAKE CERTAIN THE ROOM THERMOSTAT IS IN THE "OFF" POSITION. (THE COMPRESSOR IS NOT TO OPERATE.)
2. APPLY POWER BY CLOSING THE SYSTEM DISCONNECT SWITCH. THIS ENERGIZES THE COMPRESSOR HEATER WHICH EVAPORATES THE LIQUID REFRIGERANT IN THE CRANKCASE.
3. ALLOW 4 HOURS OR 60 MINUTES PER POUND OF REFRIGERANT IN THE SYSTEM AS NOTED ON THE UNIT RATING PLATE, WHICHEVER IS GREATER.
4. AFTER PROPER ELAPSED TIME THE THERMOSTAT MAY BE SET TO OPERATE THE COMPRESSOR.
5. EXCEPT AS REQUIRED FOR SAFETY WHILE SERVICING, DO NOT OPEN SYSTEM DISCONNECT SWITCH.

7961-411

NOTE: If compressor is allowed to run in reverse rotation for several minutes, the compressor's internal protector will trip.

All three phase ZR3 compressors are wired identical internally. As a result, once the correct phasing is determined for a specific system or installation, connecting properly phased power leads to the same Fusite terminal should maintain proper rotation direction.

Verification of proper rotation direction is made by observing that suction pressure drops and discharge pressure rises when the compressor is energized.

Reverse rotation also results in an elevated sound level over that with correct rotations, as well as, substantially reduced current draw compared to tabulated values.

The direction of rotation of the compressor may be changed by reversing any two line connections to the unit.

PHASE MONITOR

All units with three phase scroll compressors are equipped with a 3 phase line monitor to prevent compressor damage due to phase reversal.

The phase monitor in this unit is equipped with two LEDs. If the Y signal is present at the phase monitor and phases are correct, the green LED will light. If phases are reversed, the red fault LED will be lit and compressor operation is inhibited.

If a fault condition occurs, reverse two of the supply leads to the unit. Do not reverse any of the unit factory wires as damage may occur.

SERVICE HINTS

1. Caution homeowner to maintain clean air filters at all times. Also, not to needlessly close off supply and return air registers. This reduces air flow through the system, which shortens equipment service life as well as increasing operating costs.
2. Switching to heating cycle at 75° F or higher outside temperature may cause a nuisance trip of the remote reset high pressure switch. Turn thermostat off, then on to reset the high pressure switch.
3. The heat pump wall thermostats perform multiple functions. Be sure that all function switches are correctly set for the desired operating mode before trying to diagnose any reported service problems.
4. Check all power fuses or circuit breakers to be sure they are the correct rating.
5. Periodic cleaning of the outdoor coil to permit full and unrestricted airflow circulation is essential.

SEQUENCE OF OPERATION

OCCUPIED MODE

VENTILATION SEQUENCE – The ERV and indoor blower will be continuously energized when the A1 terminal is energized.

COOLING SEQUENCE – On a call for cooling, the compressor of the unit is energized to provide cooling. A call for cooling cancels dehumidification mode. Cooling mode is only available when the timer is energized. See Figure 13.

Circuit R-Y makes at thermostat pulling in compressor contactor, starting the compressor and outdoor motor. The G (indoor motor) circuit is automatically completed on any call for cooling operation or can be energized by manual fan switch on subbase for constant air circulation. Refer to Figure 13.

HEATING SEQUENCE – On a call for heating, the compressor and reversing valve of the unit are energized to provide heat pump heating. If the room temperature falls below the 2nd stage heating set point backup electric heat is energized. Heat pump heating is only available when the timer is energized. If heating is energized any call for dehumidification is ignored. If dehumidification is already energized a call for 2nd stage heating is needed to cancel dehumidification mode.

A 24V solenoid coil on reversing valve controls heating cycle operation. A thermostat demand for heat completes R-W1 circuit, pulling in compressor contactor starting compressor and outdoor motor. R-G also make starting indoor blower motor.

DEHUMIDIFICATION SEQUENCE – On a call for dehumidification the compressor and three way valve of the unit are energized to provide dehumidification. Dehumidification mode will continue until the humidistat is satisfied. If the room temperature falls below 1st stage heating setpoint, electric heat will be energized by the room thermostat and cycle to maintain room temperature. If 2nd stage heating setpoint is reached, dehumidification is de-energized and heat pump heating is energized. A call for cooling cancels dehumidification mode. Refer to Figure 14.

UNOCCUPIED MODE

Cooling, heating, emergency heat and ventilation are inhibited.

DEHUMIDIFICATION SEQUENCE – On a call for dehumidification the compressor and three way valve of the unit are energized to provide dehumidification. Dehumidification mode will continue until the humidistat is satisfied. If the room temperature falls below 65 degrees and dehumidification is energized, electric heat will be energized by the return air thermostat and cycle to maintain room temperature. See Figure 14.

OTHER CONTROL SEQUENCE

Any time the indoor coil temperature falls below 32 degrees the compressor will be de-energized until the coil temperature rises above 57 degrees.

PRESSURE SERVICE PORTS

High and low pressure service ports are installed on all units so that the system operating pressures can be observed. Pressure tables can be found later in the manual covering all models on both cooling and heating cycles. It is imperative to match the correct pressure curve to the unit by model number.

DEFROST CYCLE

The defrost cycle is controlled by temperature and time on the solid state heat pump control. See Figure 11.

When the outdoor temperature is in the lower 40° F temperature range or colder, the outdoor coil temperature is 32° F or below. This coil temperature is sensed by the coil temperature sensor mounted near the bottom of the outdoor coil. Once coil temperature reaches 30° F or below, the coil temperature sensor sends a signal to the control logic of the heat pump control and the defrost timer will start.

After 60 minutes at 30° F or below, the heat pump control will place the system in the defrost mode.

During the defrost mode, the refrigerant cycle switches back to the cooling cycle, the outdoor motor stops, electric heaters are energized, and hot gas passing through the outdoor coil melts any accumulated frost. When the temperature rises to approximately 57° F, the coil temperature sensor will send a signal to the heat pump control which will return the system to heating operations automatically.

If some abnormal or temporary condition such as a high wind causes the heat pump to have a prolonged defrost cycle, the heat pump control will restore the system to heating operation automatically after 10 minutes.

The heat pump defrost control board has an option of 30, 60 or 90 minutes setting. All models are shipped from the factory on the 60 minute pin. If special circumstances require a change to another time, remove the wire from the 60 minute terminal and reconnect to the desired terminal. The manufacturer's recommendation is for 60 minute defrost cycles. Refer to Figure 11

There is a cycle speed up jumper on the control. This can be used to reduce the time between defrost cycle operation without waiting for time to elapse.

Use a small screwdriver or other metallic object, or another 1/4 inch QC, to short between the *SPEEDUP* terminals to accelerate the HPC timer and initiate defrost.

Be careful not to touch any other terminals with the instrument used to short the *SPEEDUP* terminals. It may take up to 10 seconds with the *SPEEDUP* terminals shorted for the speedup to be completed and the defrost cycle to start.

As soon as the defrost cycle kicks in remove the shorting instrument from the SPEEDUP terminals.

Otherwise the timing will remain accelerated and run through the 1 minute minimum defrost length sequence in a matter of seconds and will automatically terminate the defrost sequence.

There is an initiate defrost jumper (sen jump) on the control that can be used at any outdoor ambient during the heating cycle to simulate a 0° coil temperature. This can be used to check defrost operation of the unit without waiting for the outdoor ambient to fall into the defrost region.

By placing a jumper across the *SEN JMP* terminals (a 1/4 inch QC terminal works best) the defrost sensor mounted on the outdoor coil is shunted out and will activate the timing circuit. This permits the defrost cycle to be checked out in warmer weather conditions without the outdoor temperature having to fall into the defrost region.

In order to terminate the defrost test the *SEN JMP* jumper must be removed. If left in place too long the compressor could stop due to the high pressure control opening because of high pressure condition created by operating in the cooling mode with outdoor fan off. Pressure will rise fairly fast as there is likely no actual frost on the outdoor coil in this artificial test condition.

There is also a 5 minute compressor time delay function built into the HPC. This is to protect the compressor from short cycling conditions. In some instances it is helpful to the service technician to override or speed up this timing period, and shorting out the *SPEEDUP* terminals for a few seconds can do this.

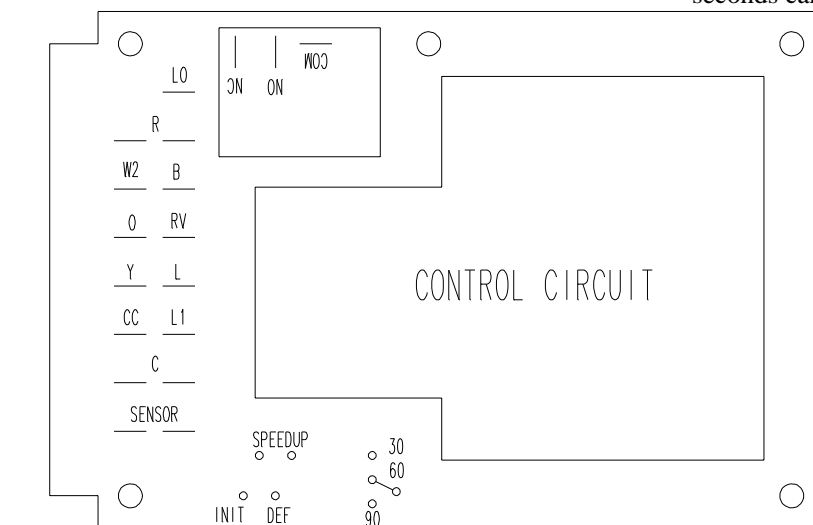

**FIGURE 11
DEFROST CONTROL BOARD**

TROUBLESHOOTING

SOLID STATE HEAT PUMP CONTROL TROUBLESHOOTING PROCEDURE

1. Turn on AC power supply to indoor and outdoor units.
2. Turn thermostat blower switch to fan "on" – the indoor blower should start. (If it doesn't, troubleshoot indoor unit and correct problem).
3. Turn thermostat blower switch to auto position. Indoor blower should stop.
4. Set system to heat or cool. Adjust thermostat to call for heat or cool – the indoor blower, compressor, and outdoor fan should start.

NOTE: If there was no power to 24 volt transformer, the compressor and outdoor fan motor will not start for 5 minutes. This is because of the compressor short cycle protection.

**TABLE 5
TROUBLESHOOTING**

Symptom	Possible Causes	What to Check	How to Check or Repair
Compressor contactor does not energize (heating or cooling)	Control circuit wiring	Check for R connectio at unit and 24 volt between R - C	Run R connection to outdoor unit to power heat pump control.
	Compressor lock out	1. Check for 24V between L1-C on heat pump control 2. Check across high presure switch.	1. If no voltage between L1-C, turn thermostat off and on again to reset high pressure switch. 2. If high pressure switch is open and will not reset, replace high pressure switch.
	Compressor short cycle protection	Check for 24 V between CC-C and Y-C on heat pump control.	If not voltage between CC-C, jumper speed up terminal, and within 10 seconds power should appear between CC-C. Remove speed up jumper after 10 seconds.
	Heat pump control defective	Check all other possible causes. Manual 2100-065	Replace heat pump control.
	Contactor defective	Check for open or shorted coil winding.	Replace contactor.
	Power phasing not correct	Check for red LED on phase monitor (3 phase units only).	Switch two power leads to the unit.
Fan outdoor motor does not run (cooling or heating except during defrost)	Motor defective	Check for open or shorted motor winding.	Replace motor.
	Motor capacitor defective	Check capacitor ratng. Check for open or shorted capacitor.	Replace capacitor.
	Heat pump control defective	Check across fan relay on heat pump control (Com-NC).	Replace heat pump control.
Reversing valve does not energize (heating only)	Reversing valve solenoid coil defective	Check for open or shorted coil.	Replace solenoid Coil.
	Heat pump control defective	Check for 24V between RV-C and B-C.	1. Check control circuit wiring. 2. Replace heat pump control.
Unit will not go into defrost (heating only)	Temperature sensor or heat pump control defective	Disconnect temperature sensor from board and jumper across speed up terminals and sen jump terminals. This should caruse the unit to go through a defrost cycle within one minute.	1. If unit goes through defrost cycle, replace temperature sensor. 2. If unit does not go through defrost cycle, replace heat pump control.
Unit will not come out of defrost (heating only)	Temperature sensor or heat pump control defective	Jumper across speed up terminals. This should cause the unit to come out of defrost within one minute.	1. If unit comes out of defrost cycle replace temperature sensor. 2. If unit does not come out of defrost cycle, replace heat pump control.

CHECKING TEMPERATURE SENSOR OUTSIDE UNIT CIRCUIT

1. Disconnect temperature sensor from board and from outdoor coil.
2. Use an ohmmeter and measure the resistance of the sensor. Also use ohmmeter to check for short or open.
3. Check resistance reading to chart of resistance. Use sensor ambient temperature. (Tolerance of part is $\pm 10\%$.)
4. If sensor resistance reads very low, then sensor is shorted and will not allow proper operation of the heat pump control.
5. If sensor is out of tolerance, shorted, open or reads very low ohms then it should be replaced.

TEMPERATURE F VS. RESISTANCE R OF TEMPERATURE SENSOR

F	R	F	R	F	R
-25.0	196871	25.0	39898	75.0	10501
-24.0	190099	26.0	38757	76.0	10247
-23.0	183585	27.0	37652	77.0	10000
-22.0	177318	28.0	36583	78.0	9760
-21.0	171289	29.0	35548	79.0	9526
-20.0	165487	30.0	34545	80.0	9299
-19.0	159904	31.0	33574	81.0	9077
-18.0	154529	32.0	32634	82.0	8862
-17.0	149355	33.0	31723	83.0	8653
-16.0	144374	34.0	30840	84.0	8449
-15.0	139576	35.0	29986	85.0	8250
-14.0	134956	36.0	29157	86.0	8057
-13.0	130506	37.0	28355	87.0	7869
-12.0	126219	38.0	27577	88.0	7686
-11.0	122089	39.0	26823	89.0	7507
-10.0	118108	40.0	26092	90.0	7334
-9.0	114272	41.0	25383	91.0	7165
-8.0	110575	42.0	24696	92.0	7000
-7.0	107010	43.0	24030	93.0	6840
-6.0	103574	44.0	23384	94.0	6683
-5.0	100260	45.0	22758	95.0	6531
-4.0	97064	46.0	22150	96.0	6383
-3.0	93981	47.0	21561	97.0	6239
-2.0	91008	48.0	20989	98.0	6098
-1.0	88139	49.0	20435	99.0	5961
0.0	85371	50.0	19896	100.0	5827
1.0	82699	51.0	19374	101.0	5697
2.0	80121	52.0	18867	102.0	5570
3.0	77632	53.0	18375	103.0	5446
4.0	75230	54.0	17898	104.0	5326
5.0	72910	55.0	17434	105.0	5208
6.0	70670	56.0	16984	106.0	5094
7.0	68507	57.0	16547	107.0	4982
8.0	66418	58.0	16122	108.0	4873
9.0	64399	59.0	15710	109.0	4767
10.0	62449	60.0	15310	110.0	4663
11.0	60565	61.0	14921	111.0	4562
12.0	58745	62.0	14544	112.0	4464
13.0	56985	63.0	14177	113.0	4367
14.0	55284	64.0	13820	114.0	4274
15.0	53640	65.0	13474	115.0	4182
16.0	52051	66.0	13137	116.0	4093
17.0	50514	67.0	12810	117.0	4006
18.0	49028	68.0	12492	118.0	3921
19.0	47590	69.0	12183	119.0	3838
20.0	46200	70.0	11883	120.0	3757
21.0	44855	71.0	11591	121.0	3678
22.0	43554	72.0	11307	122.0	3601
23.0	42295	73.0	11031	123.0	3526
24.0	41077	74.0	10762	124.0	3452

FAN BLADE SETTING DIMENSIONS

Shown in the drawing in Figure 12 are the correct fan blade setting dimensions for proper air delivery across the outdoor coil.

Any service work requiring removal or adjustment in the fan and/or motor area will require that the dimensions below be checked and blade adjusted in or out on the motor shaft accordingly.

**FIGURE 12
FAN BLADE SETTING**

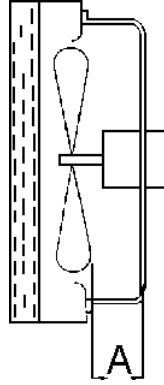

MIS-1190

**TABLE 6
FAN BLADE DIMENSIONS**

Model	Dimension A
WH422	1.75
WH484	
WH603	

REMOVAL OF FAN SHROUD

1. Disconnect all power to unit.
2. Remove the screws holding both grilles – one on each side of unit – and remove grilles.
3. Remove screws holding fan shroud to condenser and bottom – (9) screws.
4. Unwire condenser fan motor.
5. Slide complete motor, fan blade, and shroud assembly out the left side of the unit.
6. Service motor/fan as needed.
7. Reverse steps to reinstall.

REFRIGERANT CHARGE

The correct system R-22 charge is shown on the unit rating plate. Optimum unit performance will occur with a refrigerant charge resulting in a suction line temperature (6 inches from compressor) as shown in the Table 7.

**TABLE 7
SUCTION LINE TEMPERATURES**

Model	Rated Airflow	95° F OD Temperature	82° F OD Temperature
WH422	1400	52 – 54	62 – 64
WH484	1550	53 – 55	62 – 64
WH603	1700	52 – 54	61 – 63

The suction line temperatures in Table 7 are based upon 80°F dry bulb / 67 degrees F wet bulb (50 percent R.H.) temperature and rated airflow across the evaporator during cooling cycle.

**TABLE 8
RECOMMENDED OPERATING RANGES**

Model	Rated CFM *	Rated ESP *	Recommended Airflow Range
WH422	1400	.30	1600 - 1150
WH484	1550	.20	1750 - 1285
WH603	1700	.30	1950 - 1375

* Rated CFM and ESP on high speed tap.

**TABLE 9
INDOOR BLOWER PERFORMANCE
CFM @ 230V**

E.S.P. in H ₂ O	WH422, WH484				WH603			
	Low 230V		High 230V		Low 230V		High 230V	
	Dry Coil	Wet Coil	Dry Coil	Wet Coil	Dry Coil	Wet Coil	Dry Coil	Wet Coil
.0	1650	1600	1885	1800	1600	1450	2200	2000
.1	1550	1500	1770	1665	1525	1375	2100	1900
.2	1450	1400	1635	1540	---	---	2000	1800
.3	1350	1300	1500	1400	---	---	1875	1700
.4	1300	1175	1370	1285	---	---	1775	1600
.5	---	---	1250	1150	---	---	1650	1475

**TABLE 10
MAXIMUM ESP OF OPERATION
ELECTRIC HEAT ONLY**

Model Speed KW	WH422		WH484		WH603	
	High Speed	Low Speed	High Speed	Low Speed	High Speed	Low Speed
-A00	.50	.50	.50	.50	.50	.40
-A05	.50	.50	.50	.50	.50	.25
-A10	.50	.45	.50	.45	.50	.25
-B00	.50	.50	.50	.50	.50	.40
-B09	.50	.45	.50	.45	.50	.30
-C00	.50	.50	.50	.50	.50	.40
-C09	.50	.40	.50	.40	.50	.35

Values shown are for units equipped with standard 1 inch throwaway filter on 1 inch washable filter. Derate ESP by .15 for 2 inch pleated filters.

**TABLE 11
COOLING PRESSURE – (All temperatures °F)**

Model	Return Air Temperature	Pressure	75	80	85	90	95	100	105	110	115
WH422	75 deg. DB 62 deg. WB	Low Side	74	75	77	78	79	80	80	81	82
		High Side	205	220	235	251	266	282	297	313	329
	80 deg. DB 67 deg. WB	Low Side	79	80	82	83	84	85	85	86	86
		High Side	210	226	241	257	273	289	305	321	337
	85 deg. DB 72 deg. WB	Low Side	85	86	88	89	90	91	91	92	92
		High Side	217	233	250	266	283	300	316	333	349
WH484	75 deg. DB 62 deg. WB	Low Side	72	73	74	76	77	78	79	80	81
		High Side	215	229	245	261	278	295	313	332	351
	80 deg. DB 67 deg. WB	Low Side	77	78	79	81	82	83	84	86	87
		High Side	220	235	251	268	285	303	321	340	360
	85 deg. DB 72 deg. WB	Low Side	80	81	82	84	85	86	87	89	90
		High Side	228	243	260	277	295	314	332	352	373
WH603	75 deg. DB 62 deg. WB	Low Side	70	71	73	74	75	76	78	79	81
		High Side	225	233	246	262	282	306	333	364	399
	80 deg. DB 67 deg. WB	Low Side	75	76	78	79	80	81	83	85	87
		High Side	231	239	252	269	289	313	341	373	409
	85 deg. DB 72 deg. WB	Low Side	81	82	84	85	86	88	90	93	96
		High Side	240	248	261	278	299	324	353	386	410

Low side pressure ± 2 psig
High side pressure ± 5 psig

Tables are based upon rated CFM (airflow) across the evaporator coil. If there is any doubt as to correct operating charge being in the system, the charge should be removed, system evacuated and recharged to serial plate instruction.

**TABLE 12
HEATING PRESSURES – (ALL TEMPERATURES °F)**

Model	Return Air Temperature	Pressure	0	5	10	15	20	25	30	35	40	45	50	55	60
WH422	70 deg.	Low Side	21	25	27	29	32	35	39	43	48	53	58	64	71
		High Side	141	147	152	158	163	169	174	180	190	201	214	229	246
WH484	70 deg.	Low Side	24	26	27	28	29	32	35	39	44	51	58	66	74
		High Side	171	173	176	178	180	184	190	197	205	214	225	237	250
WH603	70 deg.	Low Side	23	25	27	28	30	32	33	35	42	51	62	75	91
		High Side	178	182	185	189	192	194	196	205	218	236	257	283	313

Low side pressure ± 2 psig
High side pressure ± 5 psig

Tables are based upon rated CFM (airflow) across the evaporator coil. If there is any doubt as to correct operating charge being in the system, the charge should be removed, system evacuated and recharged to serial plate instruction.

**TABLE 13
OPTIONAL ACCESSORIES**

Model	Description	WH422DA	WH422DB	WH422DC	WH484DA	WH484DB	WH484DC	WH603DA	WH603DB	WH603DC
EHWH42-A05	Heater Packages	X								
EHWH42-A10	Heater Packages	X								
EHWH42-C06	Heater Packages			X						
EHWH04-A05	Heater Packages				X			X		
EHWH04-A10	Heater Packages				X			X		
EHWH04-B09	Heater Packages		X			X			X	
EHWH04-C09	Heater Packages			X			X			X
BOP-5	Blank Off Plate	X	X	X	X	X	X	X	X	X
BFAD-5	Barometric Fresh Air Damper	X	X	X	X	X	X	X	X	X
MFAD-5	Motorized Fresh Air Damper	X	X	X	X	X	X	X	X	X
CRV-5	Classroom Ventilator with Exhaust	X	X	X	X	X	X	X	X	X
EIFM-4	Economizer with Exhaust	X	X	X	X	X	X	X	X	X
WERV-A5B	Energy Recovery Ventilator	X	X		X	X		X	X	
WERV-C5B	Energy Recovery Ventilator			X			X			X
CMH-3	Low Pressure Control (LPC)		X			X			X	
CMH-7	Low Ambient Control (LAC)		X			X			X	
CMH-9	LAC + LPC		X			X			X	
CMH-14	Outdoor Thermostat (ODT)		X	X	X	X	X	X	X	X
CMH-15	Start Kit (SK)	X								
WMCB-05	Circuit Breaker		X			X				
WMPD-01	Circuit Breaker			X			X			X
WMCB-07B	Circuit Breaker								X	
WMCB-09A	Circuit Breaker							X		
WMCB-08B	Circuit Breaker	X			X					

**TABLE 14
DEHUMIDIFICATION RELAY LOGIC BOARD**

		Inputs to Board									Outputs From Board								
		G	Y	B	W2	E1	A1	D	RAT	L	G1	BK	YO	WV	W	E	A2	TWV	L
Cooling Mode	Unoccupied	X	X								X	X	X						
Cooling Mode	Occupied	X	X				X				X	X	X				X		
Cooling Mode	w/Dehum	X	X					X			X	X	X						
1st Stage Heating	Unoccupied	X	X	X							X	X	X	X					
1st Stage Heating	Occupied						X				X	X	X	X			X		
1st Stage Heating	w/Dehum	X	X	X				X			X	X	X		X			X	
2nd Stage Heating	Unoccupied	X	X	X	X						X	X	X	X	X				
2nd Stage Heating	Occupied	X	X	X	X		X				X	X	X	X	X		X		
2nd Stage Heating	w/Dehum	X	X	X	X			X			X	X	X	X	X				
Emergency Heat	Unoccupied				X	X					X	X		X	X	X			
Emergency Heat	Occupied				X	X	X				X	X		X	X	X	X		
Emergency Heat	w/Dehum				X	X		X			X		X			X		X	
Dehumidification	Unoccupied							X			X		X					X	
Dehumidification	Occupied							X	X		X	X	X		X			X	

**FIGURE 13
BARD HEAT PUMP COOLING MODE
CIRCUIT DIAGRAM**

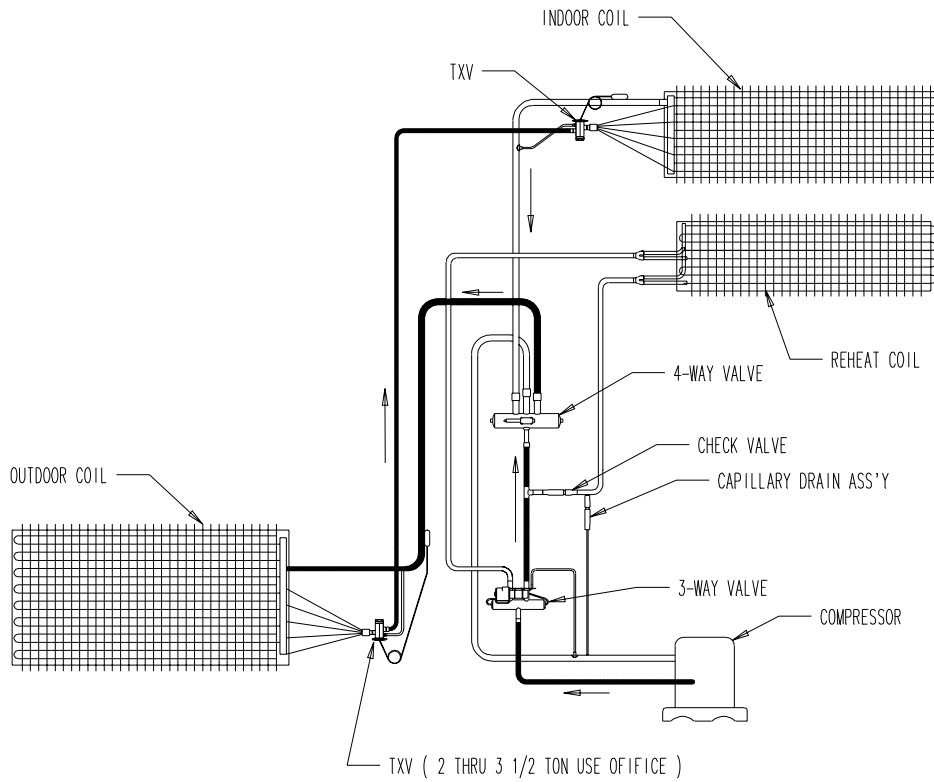

MIS-1426

**FIGURE 14
BARD HEAT PUMP DEHUMIDIFICATION MODE
CIRCUIT DIAGRAM**

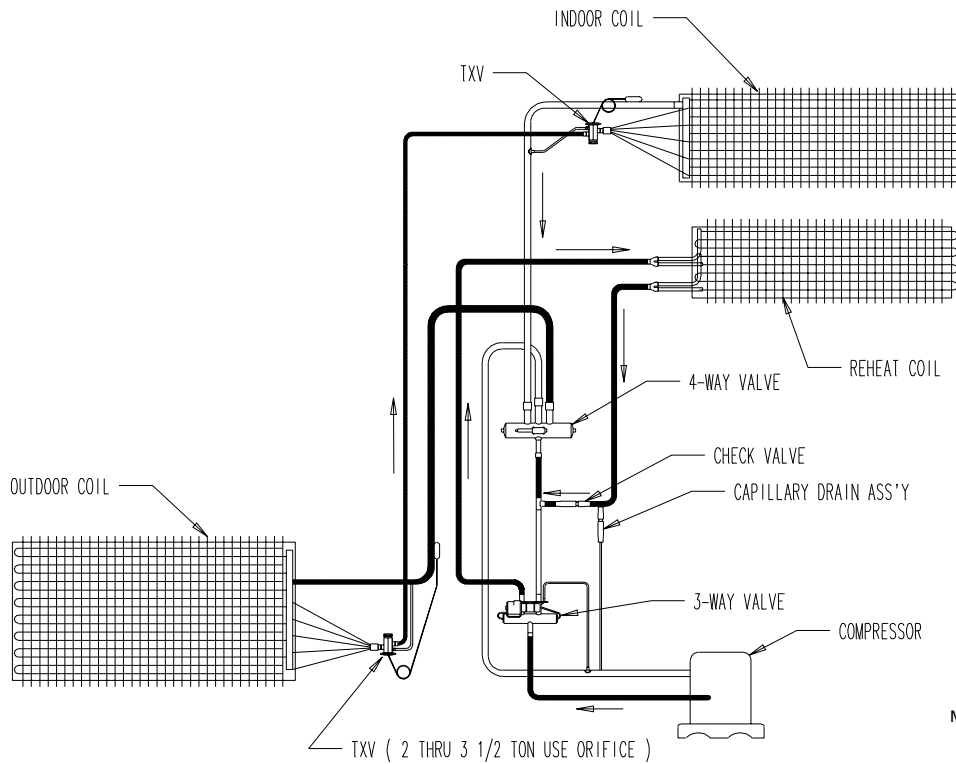

MIS-1427