INSTALLATION INSTRUCTIONS

WALL MOUNTED PACKAGE HEAT PUMPS

Models:

CH3S1

CH4S1

CH5S1

NOTE
THIS IS AN R-410A
HIGH PRESSURE
REFRIGERANT SYSTEM



CLIMATE CONTROL SOLUTIONS

Bard Manufacturing Company, Inc.
Bryan, Ohio 43506

Since 1914...Moving ahead just as planned.

Manual : 2100-455L
Supersedes: 2100-455K
File: Volume III Tab 17
Date: 11-09-11

CONTENTS

Getting Other Information and Publications

For More Information	3
----------------------------	---

Wall Mount General

Heat Pump Wall Mount Model Nomenclature	4
Shipping Damage	8
General	8
Duct Work	8
Filters	8
Condensate Drain – Evaporator	8
Wall Mounting Information	8

Installation Instructions

Optional Top Outlet Flange	9
Mounting the Unit	9
Wiring – Main Power	15
Wiring – Low Voltage Wiring	15
Low Voltage Connections	16

Figures

Figure 1 Unit Dimensions CH3S1	5
Figure 2 Unit Dimensions CH4S1 & CH5S1	6
Figure 3 Optional Top Outlet Flange	9
Figure 4 Mounting Instructions CH3S1	10
Figure 5 Mounting Instructions CH4S1/CH5S1	11
Figure 6 Electric Heat Clearance	12
Figure 7 Wall Mounting Instructions	13
Figure 8 Wall Mounting Instructions	13
Figure 9 Common Wall Mounting Installations ..	14
Figure 10 Common Wall Mounting Installations ..	15
Figure 11 Unit 24V Terminal Board	15
Figure 12 Defrost Control Board	19 & 20
Figure 13 Fan Blade Setting	23
Figure 14 Control Disassembly	28
Figure 15 Winding Test	28
Figure 16 Drip Loop	28

Start Up

Application	16
Safety Practices	17
Important Installer Note	17
Pressure Service Ports	17
High & Low Pressure Switch	17
Three Phase Scroll Compressor Start Up	17
Phase Monitor	18
Service Hints	18
Sequence of Operation	18
Compressor Current & Pressure Control Module	18
Defrost Cycle	19
Troubleshooting GE ECM™ Motors	27 & 28

Troubleshooting

Solid State Heat Pump Control Troubleshooting Procedure	21
Checking Temperature Sensor Outside Unit Circuit	22
Temperature vs. Resistance of Temperature	22
Compressor Solenoid	23
Fan Blade Setting Dimensions	23
Removal of Fan Shroud	23
Refrigerant Charge R-410A	23
Pressure Tables	25 & 26

Tables

Table 1 Electric Heat Table	4
Table 2 Electrical Specifications	7
Table 3 Thermostat Wire Size	15
Table 4 Troubleshooting	21
Table 5 Fan Blade Dimensions	23
Table 6 Indoor Blower Performance	24
Table 7 Maximum ESP of Operation	24
Table 8 Pressure Table - High Cooling	25
Table 9 Pressure Table - Low Cooling	25
Table 10 Pressure Table - High Heating	26
Table 11 Pressure Table - Low Heating	26

Getting Other Information and Publications

These publications can help you install the air conditioner or heat pump. You can usually find these at your local library or purchase them directly from the publisher. Be sure to consult current edition of each standard.

National Electrical Code ANSI/NFPA 70

Standard for the Installation ANSI/NFPA 90A
of Air Conditioning and Ventilating Systems

Standard for Warm Air ANSI/NFPA 90B
Heating and Air Conditioning Systems

Load Calculation for ACCA Manual J
Residential Winter and Summer Air Conditioning

Duct Design for Residential ACCA Manual D
Winter and Summer Air Conditioning and Equipment
Selection

FOR MORE INFORMATION, CONTACT THESE PUBLISHERS:

ACCA **Air Conditioning Contractors of America**
1712 New Hampshire Ave. N.W.
Washington, DC 20009
Telephone: (202) 483-9370
Fax: (202) 234-4721

ANSI **American National Standards Institute**
11 West Street, 13th Floor
New York, NY 10036
Telephone: (212) 642-4900
Fax: (212) 302-1286

ASHRAE **American Society of Heating, Refrigerating,
and Air Conditioning Engineers, Inc.**
1791 Tullie Circle, N.E.
Atlanta, GA 30329-2305
Telephone: (404) 636-8400
Fax: (404) 321-5478

NFPA **National Fire Protection Association**
Batterymarch Park
P.O. Box 9101
Quincy, MA 02269-9901
Telephone: (800) 344-3555
Fax: (617) 984-7057

WALL MOUNT GENERAL INFORMATION

HEAT PUMP WALL MOUNT MODEL NOMENCLATURE

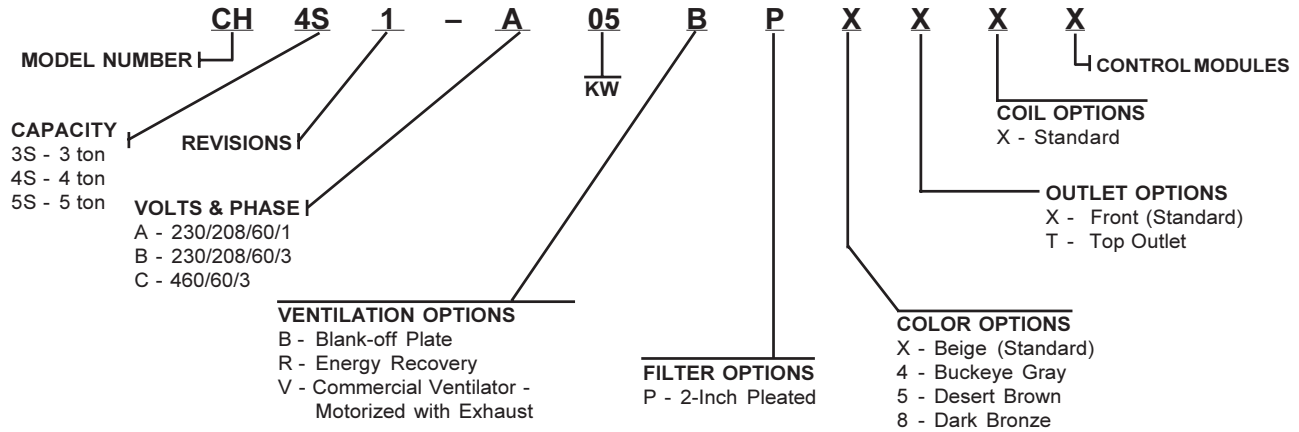
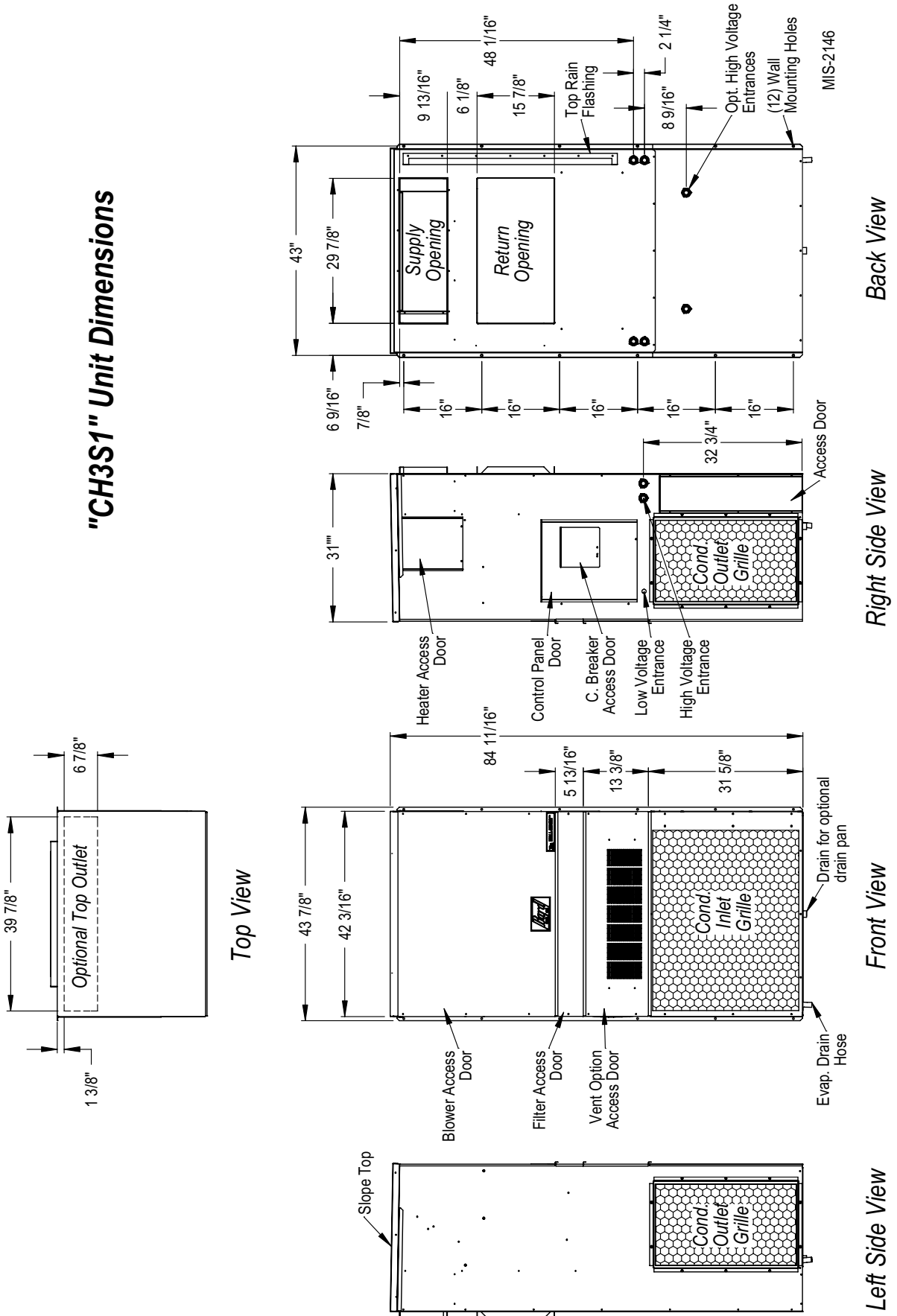

**TABLE 1
ELECTRIC HEAT TABLE**

Models	CH3S1-A				CH3S1-B				CH3S1-C		CH4S1-A CH5S1-A				CH4S1-B CH5S1-B				CH4S1-C CH5S1-C	
	240-1		208-1		240-3		208-3		460-3		240-1		208-1		240-3		208-3		460-3	
	A	BTU	A	BTU	A	BTU	A	BTU	A	BTU	A	BTU	A	BTU	A	BTU	A	BTU	A	BTU
4										16.7	13650	14.4	10240							
5	20.8	17065	18.1	12800						20.8	17065	18.1	12800							
6					14.4	20500	12.5	15360	7.2	20480					14.4	20500	12.5	15360	7.2	20480
9					21.7	30600	18.7	23030	10.8	30700					21.7	30600	18.7	23030	10.8	30700
10	41.6	34130	36.2	25600						41.6	34130	36.2	25600							
15	62.5	51200	54.1	38400	36.2	51200	31.2	38400	18.0	51200	62.5	51200	54.1	38400	36.2	51200	31.2	38400	18.0	51200
18															43.3	61400	37.5	46050	21.6	61400
20										83.2	68250	72.1	51200							

**FIGURE 1
UNIT DIMENSIONS**

"CH3S1" Unit Dimensions



**FIGURE 2
UNIT DIMENSIONS**

"CH4S1 and CH5S1" Unit Dimensions

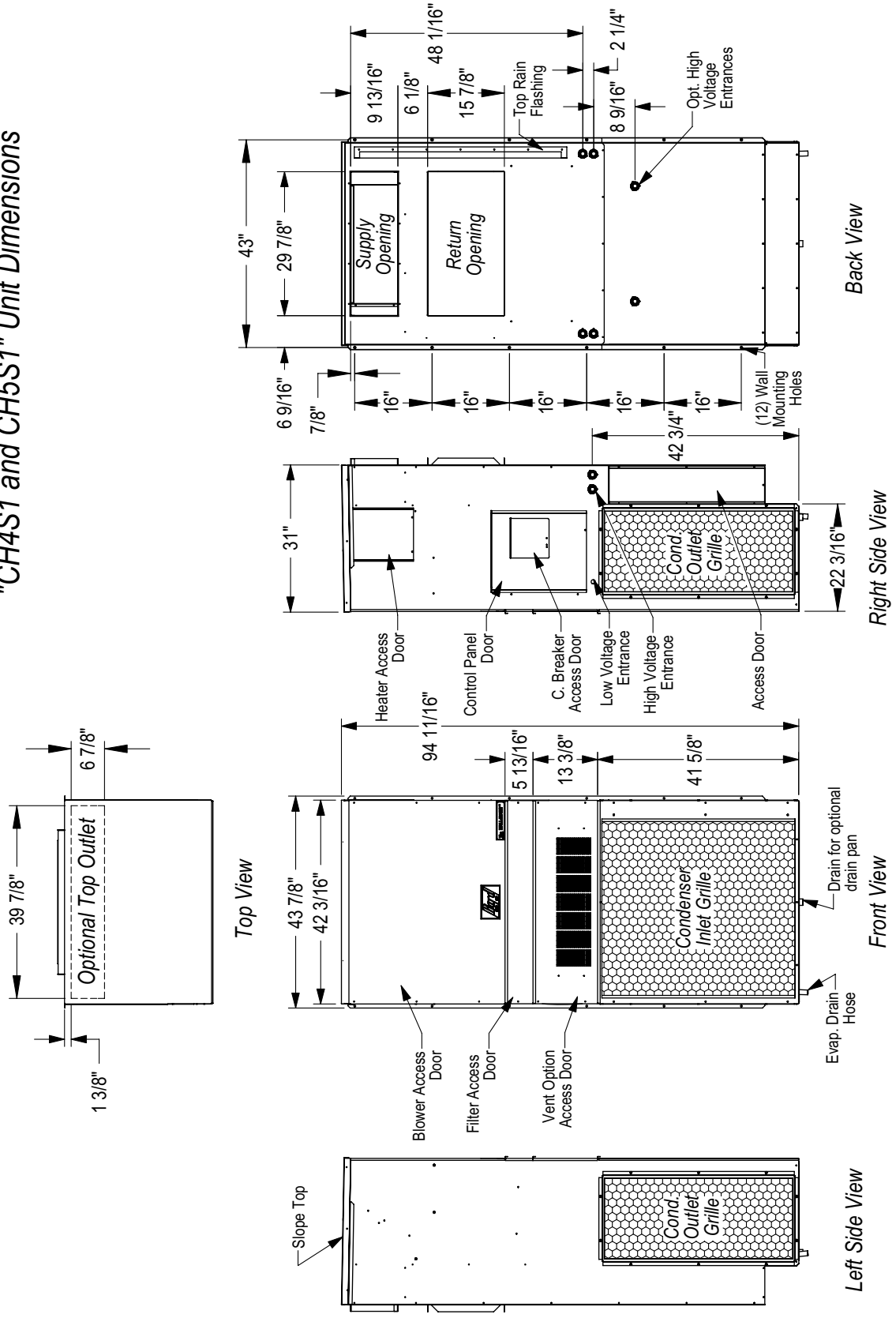

MIS-2020 A

**TABLE 2
ELECTRICAL SPECIFICATIONS**

Model	SINGLE CIRCUIT						DUAL CIRCUIT											
	Rated Volts & Phase	No. Field Power Circuits	③ Minimum Circuit Ampacity	① Maximum External Fuse or Circuit Breaker	② Field Power Wire Size	② Ground Wire Size	③ Minimum Circuit Ampacity			① Maximum External Fuse or Circuit Breaker			② Field Power Wire Size			② Ground Wire Size		
							Ckt. A	Ckt. B	Ckt. C	Ckt. A	Ckt. B	Ckt. C	Ckt. A	Ckt. B	Ckt. C	Ckt. A	Ckt. B	Ckt. C
CH3S1-A0Z	230/208-1	1	29	45	8	10	---	---	---	---	---	---	---	---	---	---	---	---
A05	230/208-1	1	55	60	6	10	---	---	---	---	---	---	---	---	---	---	---	---
A10	230/208-1	1 or 2	81	90	4	8	29	52	---	45	60	---	10	6	---	10	10	---
A15	230/208-1	1 or 2	85	90	4	8	33	52	---	45	60	---	8	6	---	10	10	---
CH3S1-B0Z	230/208-3	1	23	30	10	10	---	---	---	---	---	---	---	---	---	---	---	---
B06	230/208-3	1	41	45	8	10	---	---	---	---	---	---	---	---	---	---	---	---
B09	230/208-3	1	50	50	8	10	---	---	---	---	---	---	---	---	---	---	---	---
B15	230/208-3	1	51	60	8	10	---	---	---	---	---	---	---	---	---	---	---	---
CH3S1-C0Z	460-3	1	11	15	14	14	---	---	---	---	---	---	---	---	---	---	---	---
C06	460-3	1	20	20	12	12	---	---	---	---	---	---	---	---	---	---	---	---
C09	460-3	1	24	25	10	10	---	---	---	---	---	---	---	---	---	---	---	---
C15	460-3	1	25	30	10	10	---	---	---	---	---	---	---	---	---	---	---	---
CH4S1-A0Z	230/208-1	1	37	50	8	10	---	---	---	---	---	---	---	---	---	---	---	---
A04	230/208-1	1	57	60	6	10	---	---	---	---	---	---	---	---	---	---	---	---
A05	230/208-1	1 or 2	63	70	6	8	37	26	---	50	30	---	8	10	---	10	10	---
A10	230/208-1	1 or 2	89	90	3	8	37	52	---	50	60	---	8	6	---	10	10	---
A15	230/208-1	1 or 2	89	90	3	8	37	52	---	50	60	---	8	6	---	10	10	---
A20	230/208-1	1 or 3	113	125	2	6	37	52	26	50	60	30	6	6	10	10	10	10
CH4S1-B0Z	230/208-3	1	27	35	8	10	---	---	---	---	---	---	---	---	---	---	---	---
B06	230/208-3	1	45	50	8	10	---	---	---	---	---	---	---	---	---	---	---	---
B09	230/208-3	1	54	60	6	10	---	---	---	---	---	---	---	---	---	---	---	---
B15	230/208-3	1	54	60	6	10	---	---	---	---	---	---	---	---	---	---	---	---
B18	230/208-3	2	NA	NA	NA	NA	35	28	---	50	30	---	8	10	---	10	10	---
CH4S1-C0Z	460-3	1	14	20	12	12	---	---	---	---	---	---	---	---	---	---	---	---
C06	460-3	1	23	25	10	10	---	---	---	---	---	---	---	---	---	---	---	---
C09	460-3	1	28	30	10	10	---	---	---	---	---	---	---	---	---	---	---	---
C15	460-3	1	28	30	10	10	---	---	---	---	---	---	---	---	---	---	---	---
C18	460-3	1	31	35	8	10	---	---	---	---	---	---	---	---	---	---	---	---
CH5S1-A0Z	230/208-1	1	44	60	6	10	---	---	---	---	---	---	---	---	---	---	---	---
A04	230/208-1	1 or 2	65	70	6	8	44	21	---	60	25	---	8	10	---	10	10	---
A05	230/208-1	1 or 2	70	80	4	8	44	26	---	60	30	---	8	10	---	10	10	---
A10	230/208-1	1 or 2	96	110	3	6	44	52	---	60	60	---	8	6	---	10	10	---
A15	230/208-1	1 or 2	96	110	3	6	44	52	---	60	60	---	8	6	---	10	10	---
A20	230/208-1	1 or 3	114	125	2	6	44	52	26	60	60	30	8	6	10	10	10	10
CH5S1-B0Z	230/208-3	1	36	50	8	10	---	---	---	---	---	---	---	---	---	---	---	---
B06	230/208-3	1	54	60	6	10	---	---	---	---	---	---	---	---	---	---	---	---
B09	230/208-3	2	NA	NA	NA	NA	36	28	---	50	30	---	8	10	---	10	10	---
B15	230/208-3	2	NA	NA	NA	NA	36	28	---	50	30	---	8	10	---	10	10	---
B18	230/208-3	2	NA	NA	NA	NA	37	28	---	50	30	---	8	10	---	10	10	---
CH5S1-C0Z	460-3	1	19	25	10	10	---	---	---	---	---	---	---	---	---	---	---	---
C06	460-3	1	28	35	8	10	---	---	---	---	---	---	---	---	---	---	---	---
C09	460-3	1	32	35	8	10	---	---	---	---	---	---	---	---	---	---	---	---
C15	460-3	1	32	35	8	10	---	---	---	---	---	---	---	---	---	---	---	---
C18	460-3	1	33	35	8	10	---	---	---	---	---	---	---	---	---	---	---	---

① Maximum size of the time delay fuse or HACR type circuit breaker for protection of field wiring conductors.

② Based on 75°C copper wire. All wiring must conform to NEC and all local codes.

③ These "Minimum Circuit Ampacity" values are to be used for sizing the field power conductors. Refer to the National Electric Code (latest revision), Article 310 for power conductor sizing.

CAUTION: When more than one field power conductor circuit is run through one conduit, the conductors must be derated. Pay special attention to note 8 of table 310 regarding Ampacity Adjustment Factors when more than 3 conductors are in a raceway.

SHIPPING DAMAGE

Upon receipt of equipment, the carton should be checked for external signs of shipping damage. If damage is found, the receiving party must contact the last carrier immediately, preferably in writing, requesting inspection by the carrier's agent.

GENERAL

The equipment covered in this manual is to be installed by trained, experienced service and installation technicians.

The refrigerant system is completely assembled and charged. All internal wiring is complete.

The unit is designed for use with or without duct work. Flanges are provided for attaching the supply and return ducts.

These instructions explain the recommended method to install the air cooled self-contained unit and the electrical wiring connections to the unit.

These instructions and any instructions packaged with any separate equipment, required to make up the entire air conditioning system should be carefully read before beginning the installation. Note particularly "Starting Procedure" and any tags and/or labels attached to the equipment.

While these instructions are intended as a general recommended guide, they do not supersede any national and/or local codes in any way. Authorities having jurisdiction should be consulted before the installation is made. See Page 3 for information on codes and standards.

Size of unit for a proposed installation should be based on heat loss/heat gain calculation made according to methods of Air Conditioning Contractors of America (ACCA). The air duct should be installed in accordance with the Standards of the National Fire Protection Association for the Installation of Air Conditioning and Ventilating Systems of Other Than Residence Type, NFPA No. 90A, and Residence Type Warm Air Heating and Air Conditioning Systems, NFPA No. 90B. Where local regulations are at a variance with instructions, installer should adhere to local codes.

DUCT WORK

Any heat pump is more critical of proper operating charge and an adequate duct system than a straight air conditioning unit. All duct work, supply and return, must be properly sized for the design airflow requirement of the equipment. Air Conditioning Contractors of America (ACCA) is an excellent guide to proper sizing. All duct work or portions thereof not in the conditioned space should be properly insulated in order to both conserve energy and prevent condensation or moisture damage.

Design the duct work according to methods given by the Air Conditioning Contractors of America (ACCA). When duct runs through unheated spaces, it should be insulated with a minimum of one inch of insulation. Use insulation with a vapor barrier on the outside of the insulation. Flexible joints should be used to connect the duct work to the equipment in order to keep the noise transmission to a minimum.

These units are suitable for 0 inch clearance to combustible material. See Wall Mounting Instructions and Figures 4, 5, 6, 7 & 8 for further details.

Ducts through the walls must be insulated and all joints taped or sealed to prevent air or moisture entering the wall cavity.

Some installations may not require any return air duct. A metallic return air grille is required with installations not requiring a return air duct. The spacing between louvers on the grille shall not be larger than 5/8 inch.

NOTE: If no return air duct is used, applicable installation codes may limit this cabinet to installation only in a single story structure.

Any grille that meets with 5/8 inch louver criteria may be used. It is recommended that Bard Return Air Grille Kit RG3 through RG5 or RFG3 through RFG5 be installed when no return duct is used. Contact distributor or factory for ordering information. If using a return air filter grille, filters must be of sufficient size to allow a maximum velocity of 400 fpm.

FILTERS

A 2-inch pleated filter is supplied with each unit. The filter slides into position making it easy to service. This filter can be serviced from the outside by removing the filter access door.

CONDENSATE DRAIN – EVAPORATOR

A plastic drain hose extends from the drain pan at the top of the unit down to the unit base. There are openings in the unit base for the drain hose to pass through. In the event the drain hose is connected to a drain system of some type, it must be an open or vented type system to assure proper drainage.

WALL MOUNTING INFORMATION

1. Two holes for the supply and return air openings must be cut through the wall as shown in Figure 4.
2. On wood frame walls, the wall construction must be strong and rigid enough to carry the weight of the unit without transmitting any unit vibration.
3. Concrete block walls must be thoroughly inspected to insure that they are capable of carrying the weight of the installed unit.

INSTALLATION INSTRUCTIONS

OPTIONAL TOP OUTLET FLANGE

Top outlet flange is screwed to the back of the unit upon delivery. Flange must be installed on to the top of the unit *before* mounting. See Figure 3 for details.

MOUNTING THE UNIT

1. These units are secured by wall mounting brackets which secure the unit to the outside wall surface at both sides.
2. The unit itself is suitable for 0 inch clearance. If a combustible wall use a minimum of 30" x 10" supply opening dimensions for sizing. However, it is generally recommended that a 1-inch clearance be used for ease of installation. The supply air opening would then be 32" x 12". See Figures 4 and 5 for details.
3. Hook top rain flashing under back bend of top. Top rain flashing is shipped with unit attached to back of unit on the right side.
4. Position unit in opening and secure with 5/16 lag bolts; use 3/4 inch diameter flat washers on the lag bolts.
5. Secure rain flashing to wall and caulk across entire length of top. See Figure 4.
6. For additional mounting rigidity, the return air and supply air frames or collars can be drilled and screwed or welded to the structural wall itself (depending upon wall construction). Be sure to observe required clearance if combustible wall.
7. On side-by-side installations, maintain a minimum of 20 inches clearance on right side to allow access to control panel and heat strips, and to allow proper airflow to the outdoor coil. Additional clearance may be required to meet local or national codes.

FIGURE 3
OPTIONAL TOP OUTLET FLANGE INSTALLATIONS

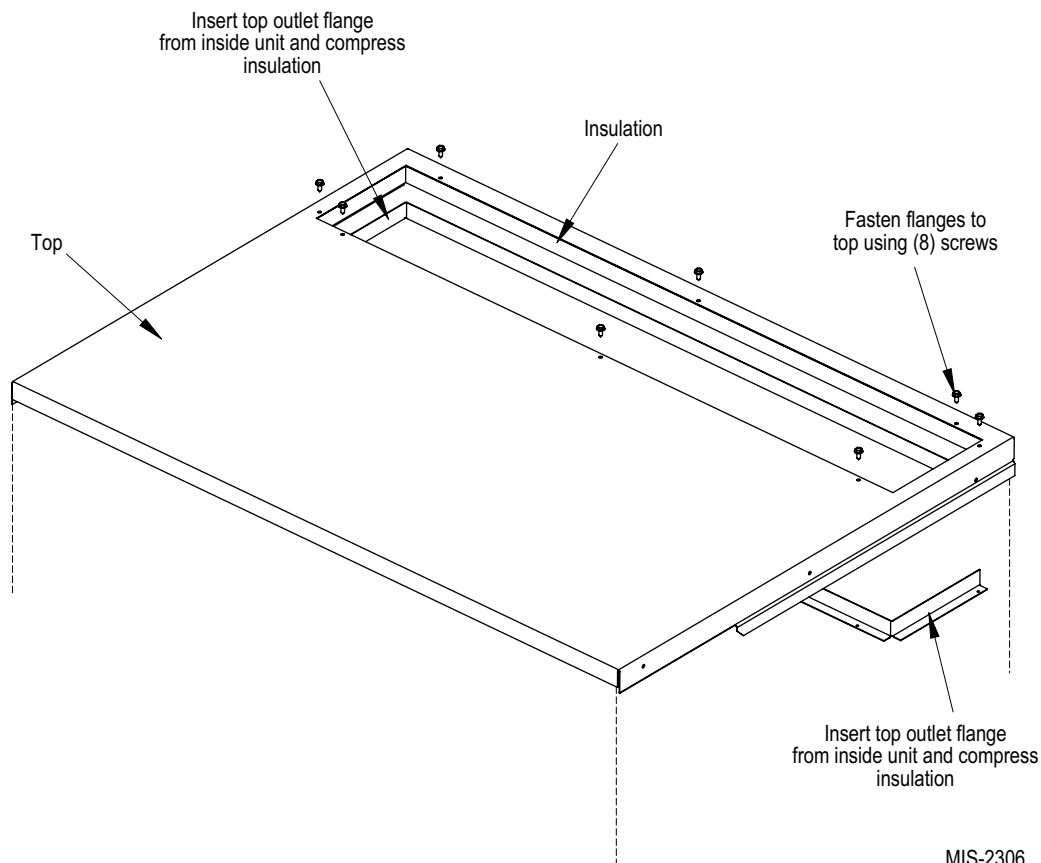

MIS-2306

FIGURE 4
MOUNTING INSTRUCTIONS

"CH3S1" Wall Mounting Instructions

	A	B	C	D	E
REQUIRED DIM. TO MAINTAIN 0" MIN. CLEARANCE FROM COMBUSTIBLE MATERIALS	30	10	6 1/2	1	6
REQUIRED DIM. TO MAINTAIN OPTIONAL 1" CLEARANCE FROM COMBUSTIBLE MATERIALS	32	12	5 1/2	2	5

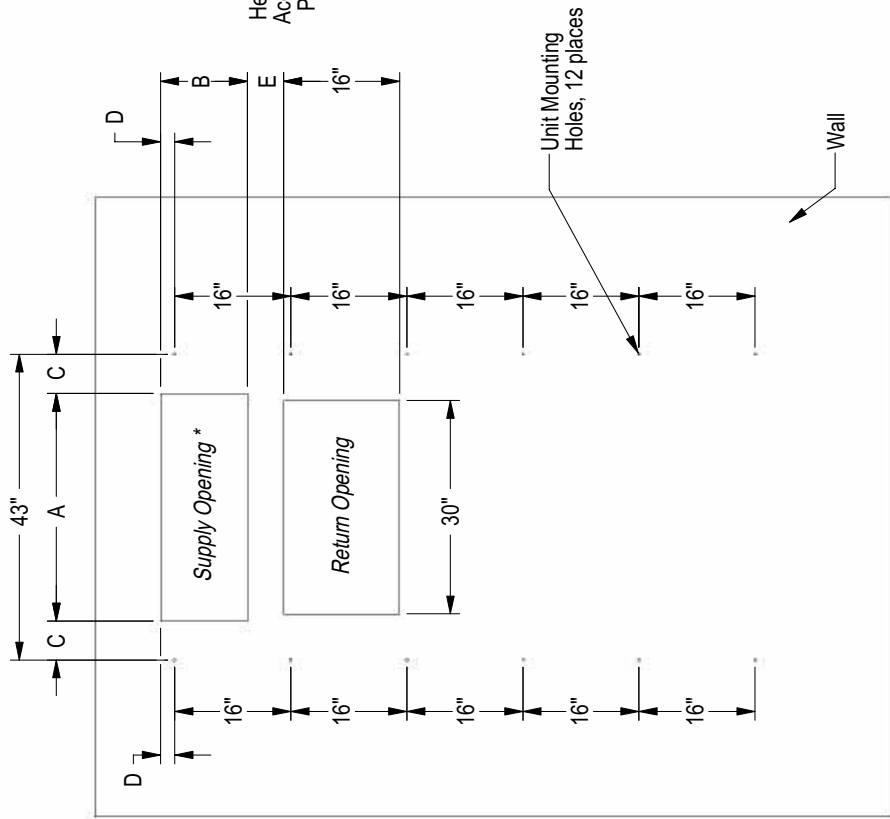
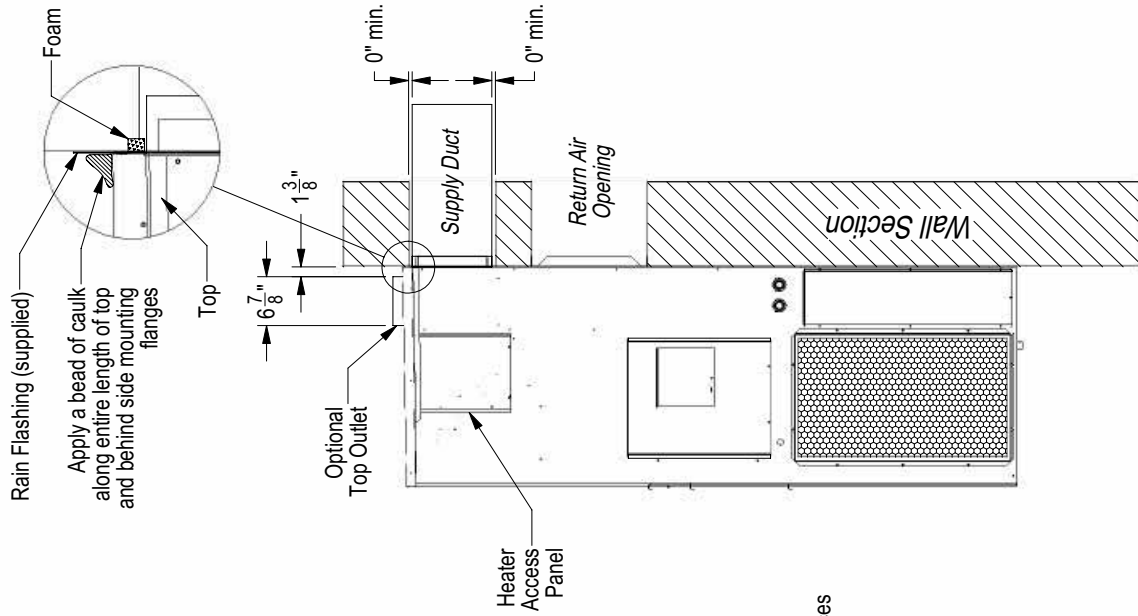

* NOT USED ON TOP OUTLET UNITS

FIGURE 5
MOUNTING INSTRUCTIONS

"CH4S1 and CH5S1" Wall Mounting Instructions

	A	B	C	D	E
REQUIRED DIMS. TO MAINTAIN 0" MIN. CLEARANCE FROM COMBUSTIBLE MATERIALS	30	10	6 1/2	1	6
REQUIRED DIMS. TO MAINTAIN OPTIONAL 1" CLEARANCE FROM COMBUSTIBLE MATERIALS	32	12	5 1/2	2	5

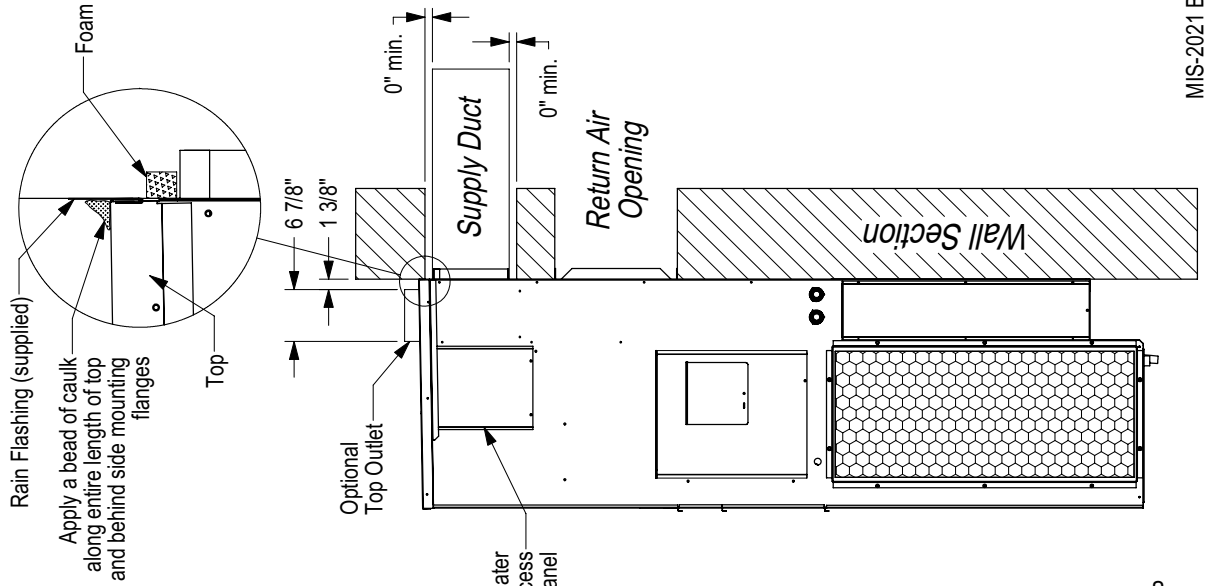
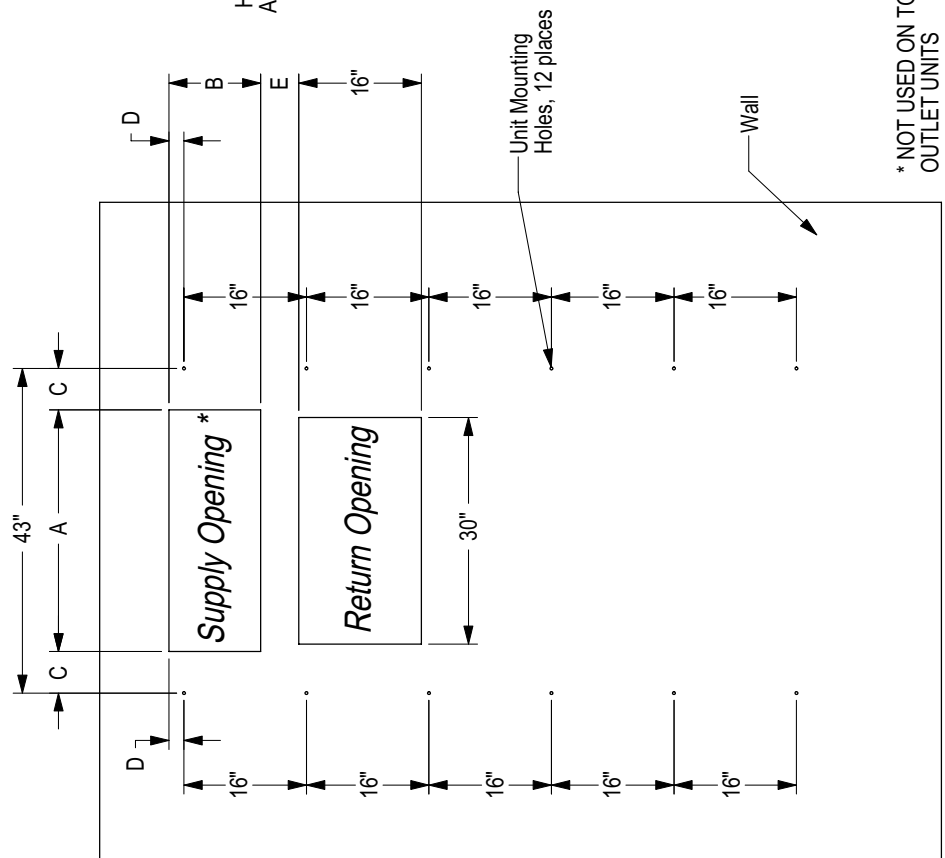

MIS-2021 B

**FIGURE 6
ELECTRIC HEAT CLEARANCE**

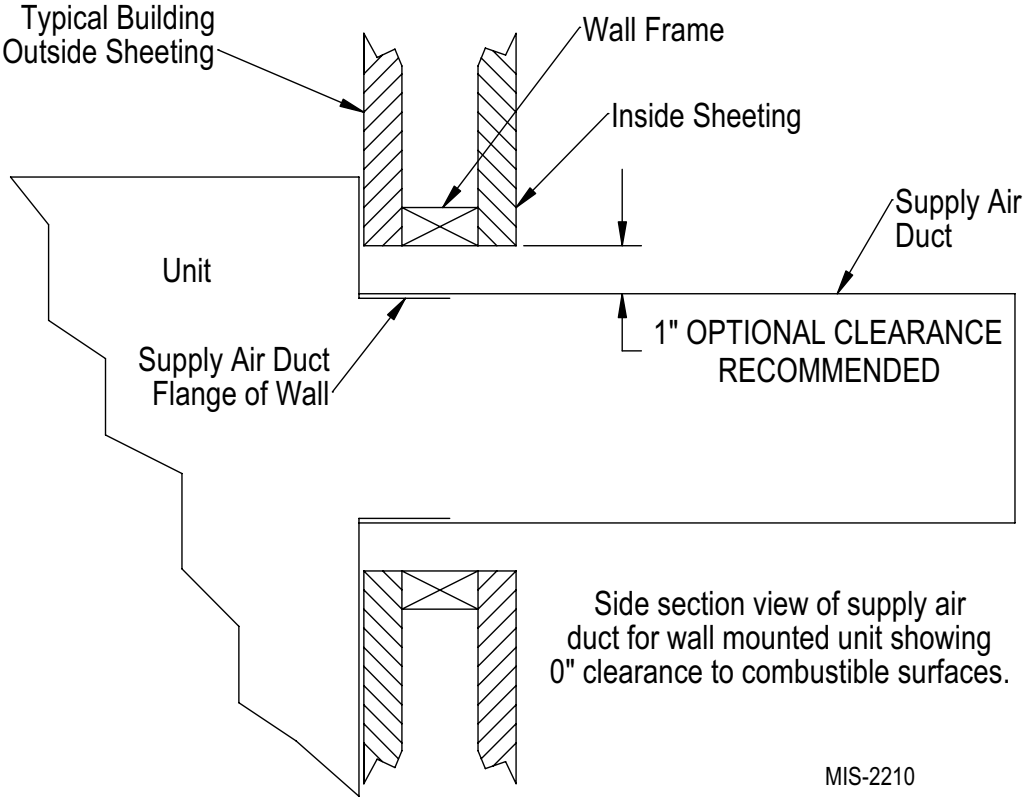

Note: This unit is approved for 0" clearance, but the optional 1" clearance is recommended. See Figures 4 & 5.

**FIGURE 7
WALL MOUNTING INSTRUCTIONS**

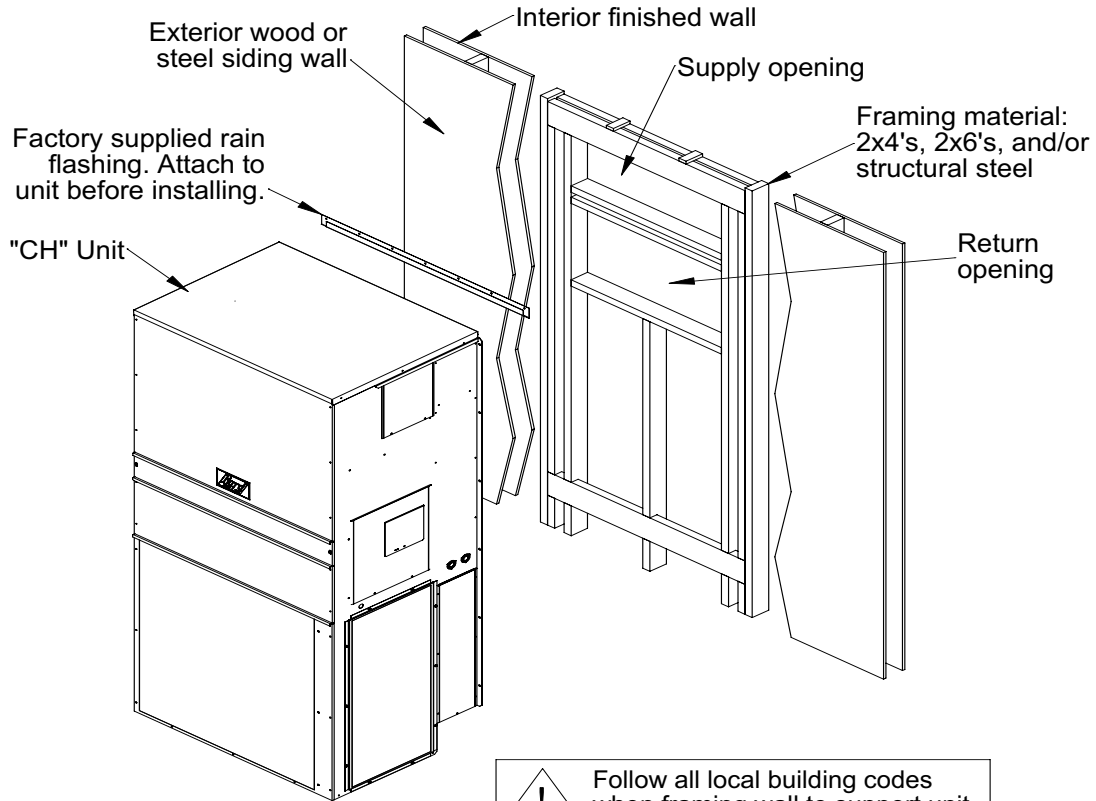

MIS-2024 A

**FIGURE 8
WALL MOUNTING INSTRUCTIONS**

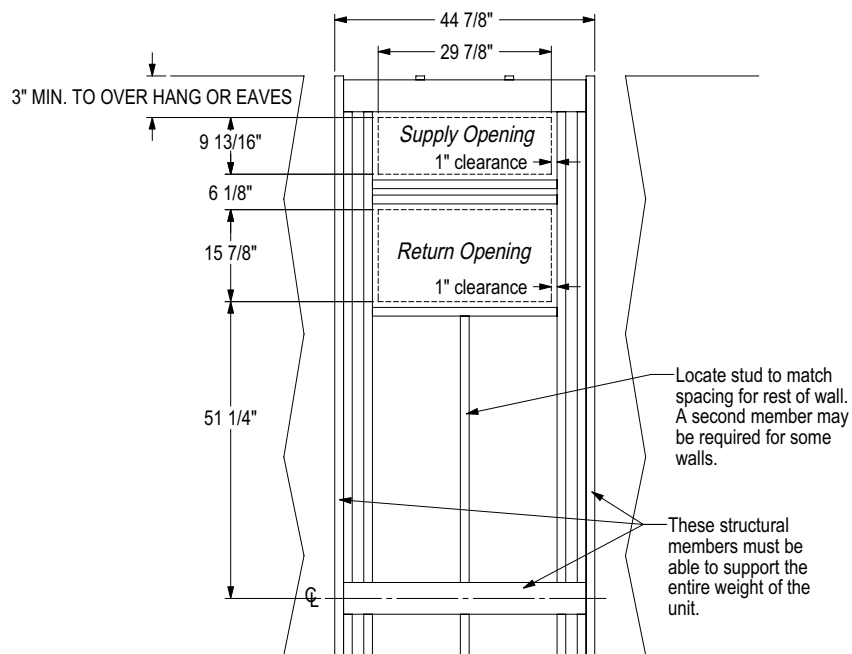

⚠ Follow all local building codes when framing wall to support unit.

MIS-2025 A

**FIGURE 9
COMMON WALL MOUNTING INSTALLATIONS**

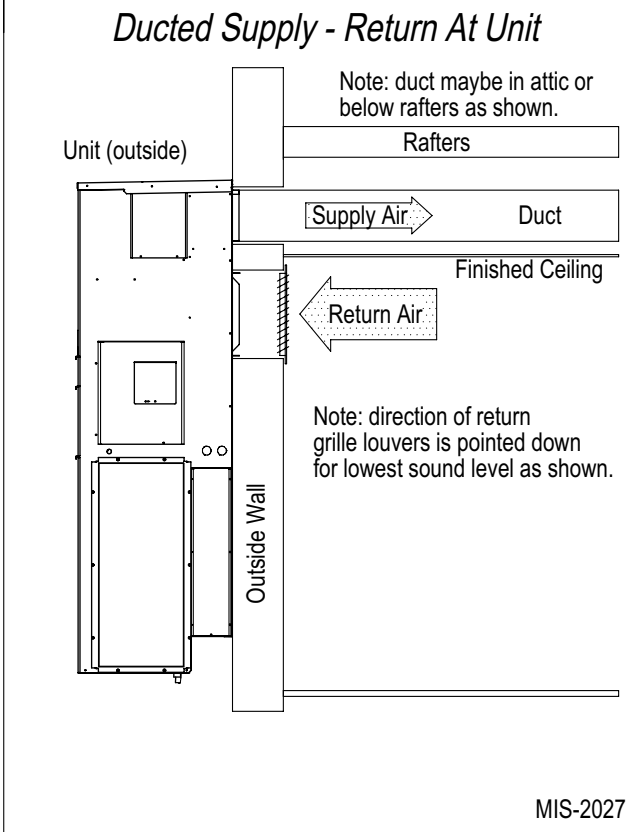
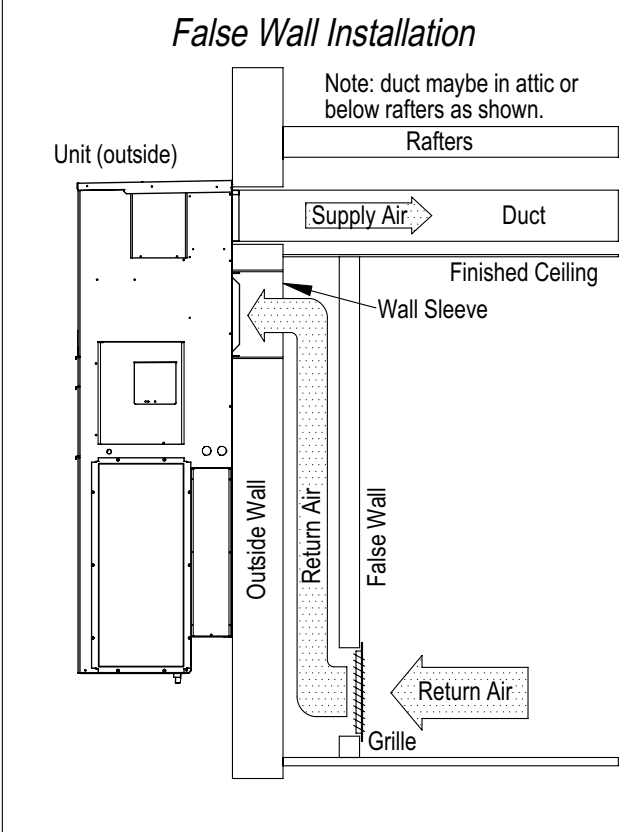
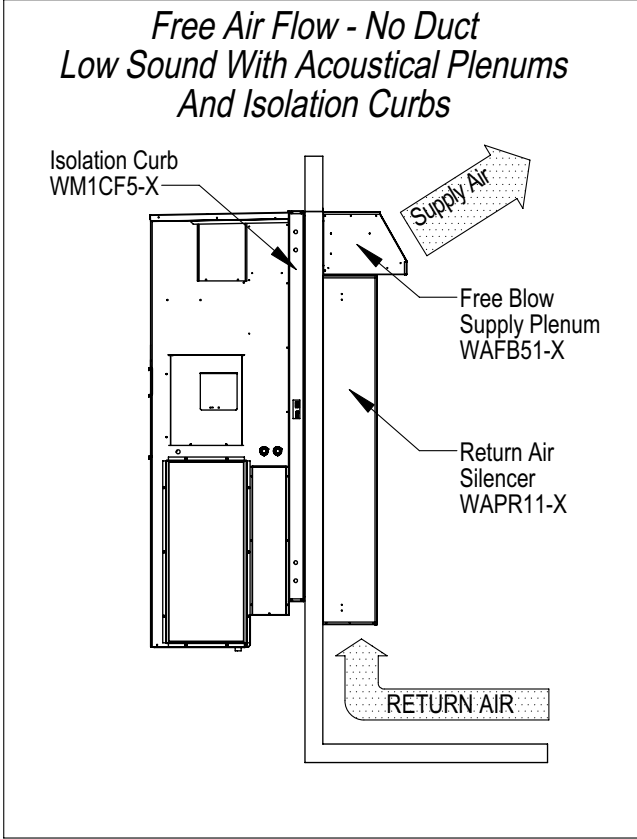
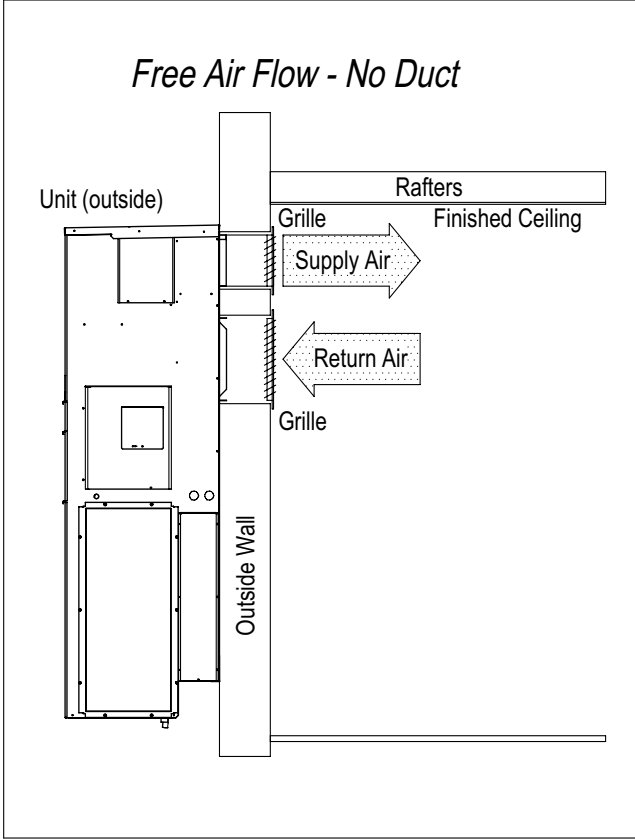

MIS-2027

FIGURE 10
COMMON WALL MOUNTING INSTALLATIONS

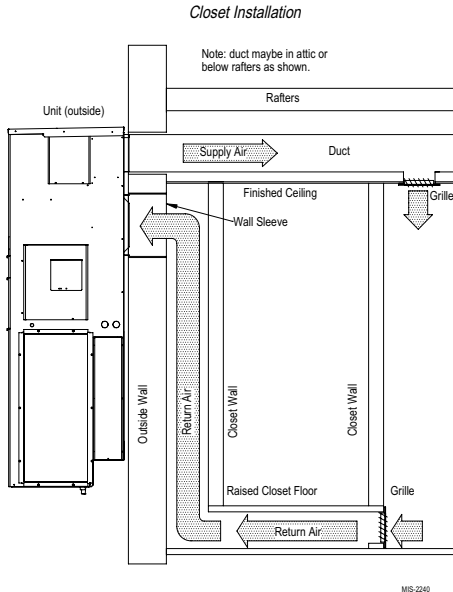

WIRING – MAIN POWER

Refer to the unit rating plate for wire sizing information and maximum fuse or “HACR” type circuit breaker size. Each outdoor unit is marked with a “Minimum Circuit Ampacity”. This means that the field wiring used must be sized to carry that amount of current. Depending on the installed KW of electric heat, there may be two field power circuits required. If this is the case, the unit serial plate will so indicate. All models are suitable only for connection with copper wire. Each unit and/or wiring diagram will be marked “Use Copper Conductors Only”. These instructions *must be* adhered to. Refer to the National Electrical Code (NEC) for complete current carrying capacity data on the various insulation grades of wiring material. All wiring must conform to NEC and all local codes.

The electrical data lists fuse and wire sizes (75°C copper) for all models including the most commonly used heater sizes. Also shown are the number of field power circuits required for the various models with heaters.

The unit rating plate lists a “Maximum Time Delay Relay Fuse” or “HACR” type circuit breaker that is to be used with the equipment. The correct size must be used for proper circuit protection and also to assure that there will be no nuisance tripping due to the momentary high starting current of the compressor motor.

The disconnect access door on this unit may be locked to prevent unauthorized access to the disconnect. To convert for the locking capability, bend the tab located in the bottom left hand corner of the disconnect opening under the disconnect access panel straight out. This tab will now line up with the slot in the door. When shut, a padlock may be placed through the hole in the tab preventing entry.

See “Start Up” section for important information on three phase scroll compressor start ups.

WIRING – LOW VOLTAGE WIRING

230 / 208V, 1 phase and 3 phase equipment have 24V transformers with dual primary voltage. All equipment leaves the factory wired on 240V tap. For 208V operation, reconnect from 240V to 208V tap. The acceptable operating voltage range for the 240 and 208V taps are:

TAP	RANGE
240	253 – 216
208	220 – 187

NOTE: 460V units require no action. The voltage should be measured at the field power connection point in the unit and while the unit is operating at full load (maximum amperage operating condition).

FIGURE 11
UNIT 24V THERMOSTAT CONNECTIONS

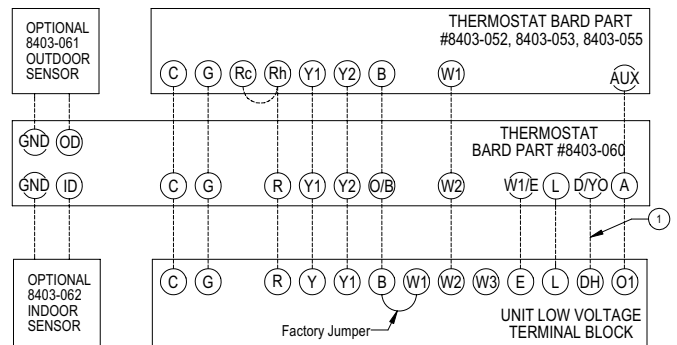

① Only needed if dehumidification is used.

Eleven (11) wires should be run from thermostat subbase to the 24V terminal board in the unit. An eleven conductor, 18 gauge copper color-coded thermostat cable is recommended. The connection points are shown in Figure 11. An additional wire is needed if dehumidification is used.

IMPORTANT

Only the thermostat combinations as shown above will work with this equipment.

TABLE 3
THERMOSTAT WIRE SIZE

Transformer VA	FLA	Wire Gauge	Maximum Distance In Feet
65	2.3	20 gauge	45
		18 gauge	60
		16 gauge	100
		14 gauge	160
		12 gauge	250

LOW VOLTAGE CONNECTIONS

These units use a grounded 24 volt AC low voltage circuit and require at least a 2 stage heating and a 2 stage cooling thermostat.

“G” terminal is the *fan input*.

“Y” terminal is the *compressor Stage 1 input*.

“Y1” terminal is the *compressor Stage 2 input*.

“B” terminal is the *reversing valve input*. The reversing valve must be energized for heating mode.

“R” terminal is *24 VAC hot*.

“C” terminal is *24 VAC grounded*.

“L” terminal is *compressor lockout output*. This terminal is activated on a high or low pressure trip by the electronic heat pump control. This is a 24 VAC output.

“W2” terminal is *second stage heat* (if equipped).

“O1” terminal is the *ventilation input*. This terminal energizes any factory or field installed ventilation option.

“DH” terminal is the *dehumidifier input*. This terminal energizes the factory or field installed dehumidifier option.

“E” terminal is the *emergency heat input*. This terminal energizes the emergency heat relay if equipped.

NOTE: For total and proper control using DDC, a minimum of 8 controlled outputs are required (6 if no ventilation or dehumidifier option is installed). For proper system operation under Emergency Heat conditions where the compressor needs to be deactivated, the B-W2-E outputs need to be energized. Removing the Y (compressor) signal alone turns the compressor off, but does not activate the additional circuitry embedded in the heat pump for proper and complete operation.

LOW VOLTAGE CONNECTIONS FOR DDC CONTROL

Fan Only	Energize G
Cooling Mode 1st Stage	Energize Y, G
Cooling Mode 2nd Stage	Energize Y, Y1, G
Heat Pump Heating 1st Stage	Energize Y, G, B
Heat Pump Heating 2nd Stage	Energize Y, Y1, G, B
3rd Stage Heating w/Heat Pump (if employed)	Energize G, W2, Y, B, Y1
Ventilation	Energize G, O1
Dehumidifier	Energize DH
Emergency Heat	Energize B, W2, E, G

START UP

These units require R-410A refrigerant & Polyol Ester oil.

APPLICATION:

1. Use separate service and manufacturing equipment to avoid cross contamination of oil and refrigerants.
2. Use recovery equipment rated for R-410A refrigerant.
3. Use manifold gauges rated for R-410A (800 psi/250 psi low).
4. R-410A is a binary blend of HFC-32 and HFC-125.
5. R-410A is nearly azeotropic - similar to R-22 and R-12. Although nearly azeotropic, charge with liquid refrigerant.
6. R-410A operates at 40-70% higher pressure than R-22, and systems designed for R-22 cannot withstand this higher pressure.
7. R-410A has an ozone depletion potential of zero, but must be reclaimed due to its global warming potential.
8. R-410A compressors use Polyol Ester oil.
9. Polyol Ester oil is hygroscopic; it will rapidly absorb moisture and strongly hold this moisture in the oil.
10. A liquid line dryer must be used - even a deep vacuum will not separate moisture from the oil.
11. Limit atmospheric exposure to 15 minutes - **MAXIMUM**.
12. If compressor removal is necessary, always plug compressor immediately after removal. Purge with small amount of nitrogen when inserting plugs.

START UP CONT'D.

SAFETY PRACTICES:

1. Never mix R-410A with other refrigerants.
2. Use gloves and safety glasses, Polyol Ester oils can be irritating to the skin, and liquid refrigerant will freeze the skin.
3. Never use air and R-410A to leak check; the mixture may become flammable.
4. Do not inhale R-410A – the vapor attacks the nervous system, creating dizziness, loss of coordination and slurred speech. Cardiac irregularities, unconsciousness and ultimate death can result from breathing this concentration.
5. Do not burn R-410A. This decomposition produces hazardous vapors. Evacuate the area if exposed.
6. Use only cylinders rated DOT4BA/4BW 400.
7. Never fill cylinders over 80% of total capacity.
8. Store cylinders in a cool area, out of direct sunlight.
9. Never heat cylinders above 125°F.
10. Never trap liquid R-410A in manifold sets, gauge lines or cylinders. R-410A expands significantly at warmer temperatures. Once a cylinder or line is full of liquid, any further rise in temperature will cause it to burst.

IMPORTANT INSTALLER NOTE

For improved start-up performance, wash the indoor coil with a dish washing detergent.

PRESSURE SERVICE PORTS

R-410A requires high pressure hose connections and gauges. High and Low pressure service ports are installed on all units so that the system operating pressures can be observed. Pressure tables can be found later in the manual covering all models on both cooling and heating cycles. It is imperative to match the correct pressure table to the unit by model number.

HIGH & LOW PRESSURE SWITCH

All models are supplied with a remote reset high and low pressure switch. If tripped, this pressure switch may be reset by turning the thermostat off then back on again.

High/Low Pressure control provides protection for the compressor. In the event system pressures go above 575 PSI or below 32 PSI, in either cooling or heating mode, the compressor will be stopped. This high pressure switch is located on the discharge line and is matched with Bard Part #8406-113. This will activate the “L” terminal of the low voltage terminal strip. This terminal can be used for remote indication of a pressure lockout. The lockout circuit will hold compressor off line. When the system problem is corrected, the unit operation can be restored by turning the main power supply off and then back on, or reset the room thermostat. The low pressure control has a bypass circuit built into the Defrost Control Board.

THREE PHASE SCROLL COMPRESSOR START UP INFORMATION

Scroll compressors, like several other types of compressors, will only compress in one rotational direction. Direction of rotation is not an issue with single phase compressors since they will always start and run in the proper direction.

However, three phase compressors will rotate in either direction depending upon phasing of the power. Since there is a 50-50 chance of connecting power in such a way as to cause rotation in the reverse direction, verification of proper rotation must be made. All three phase units incorporate a phase monitor to ensure proper field wiring. See the “Phase Monitor” section later in this manual.

Verification of **proper rotation** must be made any time a compressor is changed or rewired. If improper rotation is corrected at this time there will be no negative impact on the durability of the compressor. However, reverse operation for over one hour may have a negative impact on the bearing due to oil pump out.

NOTE: If compressor is allowed to run in reverse rotation for several minutes, the compressor's internal protector will trip.

All three phase ZR3 compressors are wired identically internally. As a result, once the correct phasing is determined for a specific system or installation, connecting properly phased power leads to the same Fusite terminal should maintain proper rotation direction.

Verification of proper rotation direction is made by observing that suction pressure drops and discharge pressure rises when the compressor is energized. Reverse rotation also results in an elevated sound level over that with correct rotations, as well as substantially reduced current draw compared to tabulate values.

The direction of rotation of the compressor may be changed by reversing any two line connections to the unit.

PHASE MONITOR

All units with three phase compressors are equipped with a 3 phase line monitor to prevent compressor damage due to phase reversal.

The phase monitor in this unit is equipped with two LEDs. If the Y signal is present at the phase monitor and phases are correct, the green LED will light. If phases are reversed, the red fault LED will be lit and compressor operation is inhibited.

If a fault condition occurs, shut off main power and reverse two of the supply leads to the unit. Do not reverse any of the unit factory wires as damage may occur.

SERVICE HINTS

1. Caution owner/operator to maintain clean air filters at all times. Also, not to needlessly close off supply and return air registers. This reduces airflow through the system, which shortens equipment service life as well as increasing operating costs.
2. Switching to heating cycle at 75°F or higher outside temperature may cause a nuisance trip of the remote reset high pressure switch. Turn thermostat off then on to reset the high pressure switch.
3. The heat pump wall thermostats perform multiple functions. Be sure that all function switches are correctly set for the desired operating mode before trying to diagnose any reported service problems.
4. Check all power fuses or circuit breakers to be sure they are the correct rating.
5. Periodic cleaning of the outdoor coil to permit full and unrestricted airflow circulation is essential.

SEQUENCE OF OPERATION

COOLING STAGE 1 – Circuit R-Y makes at thermostat pulling in compressor contactor, starting the compressor and outdoor motor. The G (indoor motor) circuit is automatically completed on any call for cooling operation or can be energized by manual fan switch on subbase for constant air circulation.

COOLING STAGE 2 – Circuit R-Y1 makes at the thermostat energizing the 2nd stage solenoid in the compressor. Default position is not energized. Compressor will run at low capacity until this solenoid is energized.

HEATING STAGE 1 – A 24V solenoid coil on reversing valve controls heating cycle operation. Two thermostat options, one allowing “Auto” changeover from cycle to cycle and the other constantly energizing solenoid coil during heating season and thus eliminating pressure equalization noise except during defrost, are to be used. On “Auto” option a circuit is completed from R-B and R-Y on each heating “on” cycle, energizing reversing valve solenoid and pulling in compressor contactor

starting compressor and outdoor motor. R-G also make starting indoor blower motor. Heat pump heating cycle now in operation. The second option has no “Auto” changeover position, but instead energizes the reversing valve solenoid constantly whenever the system switch on subbase is placed in “Heat” position, the “B” terminal being constantly energized from R. A thermostat demand for Stage 1 heat completes R-Y circuit, pulling in compressor contactor starting compressor and outdoor motor. R-G also make starting indoor blower motor.

HEATING STAGE 2 – Circuit R-Y2 makes at the thermostat energizing the 2nd stage solenoid in the compressor.

COMPRESSOR CURRENT & PRESSURE CONTROL MODULE

The compressor control module monitors compressor current and pressure and prevents internal overload trips due to low voltage or extremely high ambient temperatures by de-energizing the full capacity compressor solenoid. The control monitors current to the compressor and discharge pressure. If current is sensed that is in excess of 93% of the compressor maximum continuous current rating or pressure is sensed greater than 540 PSI (located on liquid line and is marked with Bard Part #8406-111), the compressor control module de-energizes the second stage solenoid in the compressor for a time as determined by the time potentiometer on the compressor control module. This will drop the current draw and pressure and allow the compressor to run at 75 percent of capacity rather than not at all. Once the time period has elapsed the full capacity compressor solenoid will re-energize and try again to run at full capacity. If the pressure or current is exceeded again, the coil will again de-energize. This sequence will repeat until the ambient temperature drops or the line voltage increases enough that the trip values are not exceeded.

The relay on the compressor control module is a single pole double throw relay. The full capacity compressor solenoid connects to the common terminal of the relay. Once current is sensed by the compressor control module, the relay closes and the second stage cooling call (if present) is sent to the full capacity compressor solenoid. This sequence prevents damage to the full capacity compressor solenoid by ensuring that the solenoid is not energized when the compressor is not running. A brief time delay in this sequence also prevents locked rotor amperage during start-up from tripping the device and engaging the time delay period.

DEFROST CYCLE

The defrost cycle is controlled by temperature and time on the solid state heat pump control.

When the outdoor temperature is in the lower 40°F temperature range or colder, the outdoor coil temperature is 32°F or below. This coil temperature is sensed by the coil temperature sensor mounted near the bottom of the outdoor coil. Once coil temperature reaches 30°F or below, the coil temperature sensor sends a signal to the control logic of the heat pump control and the defrost timer will start accumulating run time.

After 30, 60 or 90 minutes of heat pump operation at 30°F or below, the heat pump control will place the system in the defrost mode.

During the defrost mode, the refrigerant cycle switches back to the cooling cycle, the outdoor motor stops, electric heaters are energized, and hot gas passing through the outdoor coil melts any accumulated frost. When the temperature rises to approximately 57°F, the coil temperature sensor will send a signal to the heat pump control which will return the system to heating operations automatically.

If some abnormal or temporary condition such as a high wind causes the heat pump to have a prolonged defrost cycle, the heat pump control will restore the system to heating operation automatically after 8 minutes.

The heat pump defrost control board has an option of 30, 60 or 90-minute setting. By default, this Kit is shipped from the factory with the defrost time on the 60 minute pin. If circumstances require a change to another time, remove the wire from the 60-minute terminal and reconnect to the desired terminal.

Refer to Figure 12 for the manufacturer's recommended defrost cycle length.

There is a cycle speed up jumper on the control. This can be used for testing purposes to reduce the time between defrost cycle operation without waiting for time to elapse.

Use a small screwdriver or other metallic object, or another ¼ inch QC, to short between the *SPEEDUP* terminals to accelerate the HPC timer and initiate defrost.

Be careful not to touch any other terminals with the instrument used to short the *SPEEDUP* terminals. It may take up to 10 seconds with the *SPEEDUP* terminals shorted for the speedup to be completed and the defrost cycle to start.

As soon as the defrost cycle kicks in remove the shorting instrument from the SPEEDUP terminals. Otherwise the timing will remain accelerated and run through the 1-minute minimum defrost length sequence in a matter of seconds and will automatically terminate the defrost sequence.

FIGURE 12 — DEFROST CONTROL BOARD

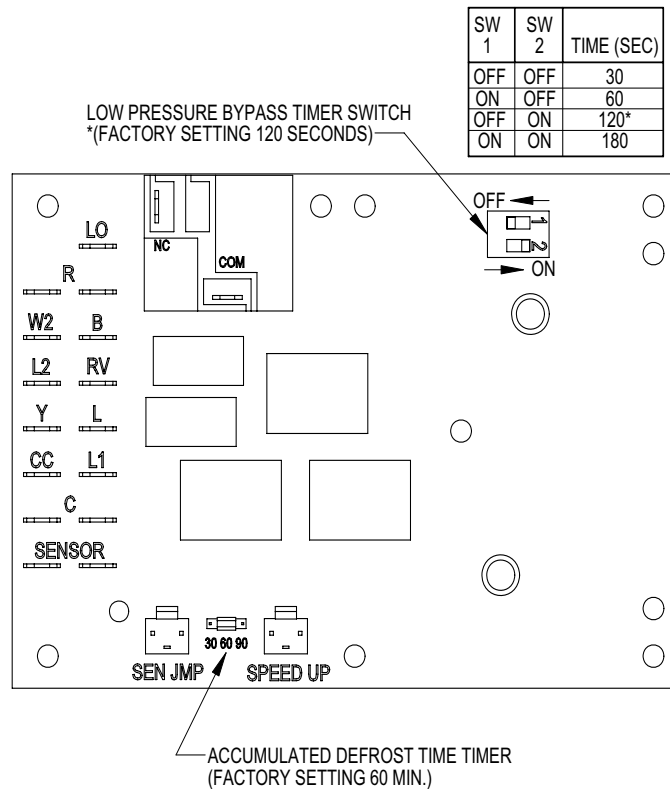

MIS-2668 A

WALL MOUNTS	60 MIN.
PACKAGE UNITS	60 MIN.
Q-TEC CLASSROOM UNITS	30 MIN.
I-TEC CLASSROOM UNITS	90 MIN.

There is an initiate defrost jumper (sen jump) on the control that can be used at any outdoor ambient during the heating cycle to simulate a 0° coil temperature.

This can be used to check defrost operation of the unit without waiting for the outdoor ambient to fall into the defrost region.

By placing a jumper across the *SEN JMP* terminals (a ¼ inch QC terminal works best) the defrost sensor mounted on the outdoor coil is shunted out & will activate the timing circuit. This permits the defrost cycle to be checked out in warmer weather conditions without the outdoor temperature having to fall into the defrost region.

In order to terminate the defrost test the *SEN JMP* jumper must be removed. If left in place too long, the compressor could stop due to the high pressure control opening because of high pressure condition created by operating in the cooling mode with outdoor fan off. Pressure will rise fairly fast as there is likely no actual frost on the outdoor coil in this artificial test condition.

There is also a 5-minute compressor time delay function built into the HPC. This is to protect the compressor from short cycling conditions. The board's LED will have a fast blink rate when in the compressor time delay. In some instances, it is helpful to the service technician to override or speed up this timing period, and shorting out the *SPEEDUP* terminals for a few seconds can do this.

Low Pressure Switch Bypass Operation - The control has a selectable (SW1) low pressure switch bypass set up to ignore the low pressure switch input during the first (30, 60, 120 or 180 seconds) of “Y” operation.

After this period expires, the control will then monitor the low pressure switch input normally to make sure that the switch is closed during “Y” operation.

High Pressure Switch Operation - The control has a built-in lockout system that allows the unit to have the high pressure switch trip up to two times in one hour and only encounter a “soft” lockout. A “soft” lockout shuts the compressor off and waits for the pressure switch to reset, which at that point then allows the compressor to be restarted as long as the 5-minute short cycle timer has run out. If the high pressure switch trips a third time within one hour, the unit is in “hard” lockout indicating something is certainly wrong and it will not restart itself.

TROUBLESHOOTING

SOLID STATE HEAT PUMP CONTROL TROUBLESHOOTING PROCEDURE

- NOTE:** A thorough understanding of the defrost cycle sequence is essential. Review that section earlier in this manual prior to troubleshooting the control. Turn on AC power supply to unit.
- Turn thermostat blower switch to “fan on” – the indoor blower should start. (If it doesn’t, troubleshoot indoor unit and correct problem.)
- Turn thermostat blower to “auto” position. Indoor blower should stop. **NOTE:** Many models have a 1-minute blower time delay on “off” command; wait for this to time-out.
- Set system switch to “heat” or “cool”. Adjust thermostat to call for heat or cool. The indoor blower, compressor and outdoor fan should start.

NOTE: If there was no power to 24 volt transformer, the compressor and outdoor fan motor will not start for 5 minutes. This is because of the compressor short cycle protection.

LED BLINK CODES

BLINK	FUNCTION
Slow	Normal function (1.0 sec on/1.0 sec off)
Fast	ASCD timer active (0.1 sec on/0.1 sec off)
1	Low pressure switch failure
2	High pressure switch failure/“Soft” Lockout
3	Defrost mode active
4	High pressure switch failure/“Hard” Lockout

**TABLE 4
TROUBLESHOOTING**

Symptom	Description, Check & Possible Causes	What & How to Check / Repair
Compressor will not start (heating or cooling)	1. Check for LED illumination. Is there an LED illuminated on the board (flashing)?	Yes = go to Step #2; No = go to Step #3
	2. Check for error codes. Is the LED flashing a Code?	Yes = go to Step #4; No = go to Step #8
	3. Check for power at board. Is there 24 volts AC between R and C?	Yes = go to Step #13; No = go to Step #9
	4. Check codes. What code is blinking?	Code "1", go to Step #6; Code "2", go to Step#7; Fast Blink, go to Step #5
	5. Compressor delay active. Wait for 5 minute delay or jump board's "speed up pins".	Check for proper operation; if still needed, go back to Step #1.
	6. Low pressure fault.	Check wiring circuit and unit pressures.
	7. High pressure fault.	Check wiring circuit and unit pressures.
	8. Check for Compressor input signal. Is there 24 volts AC between Y and C?	Yes = go to Step #10; No = go to Step #11
	9. No power to board.	The unit either does not have unit voltage, the transformer is bad or the unit wiring is incorrect.
	10. Check for Compressor output signal. Is there 24 volts AC between CC & C?	Yes = go to Step #12; No = go to Step #13
	11. No "Y" compressor input signal.	Check thermostat wiring, incorrect phase of unit (see section on Phase Monitor), and finally unit wiring.
	12. No "CC" compressor output signal.	Check compressor contactor for proper operation and finally check compressor.
	13. Faulty board.	Replace defrost board.
Fan outdoor motor does not run (cooling or heating except during defrost)	Heat pump control defective	Check across fan relay on heat pump control. (Com-NC) Replace heat pump control.
	Motor defective	Check for open or shorted motor winding. Replace motor.
	Motor capacitor defective	Check capacitor rating. Check for open or shorted capacitor. Replace capacitor.
Reversing valve does not energize (heating only)	Heat pump control defective	Check for 24V between RV-C and B-C. 1. Check control circuit wiring. 2. Replace heat pump control
	Reversing valve solenoid coil defective	Check for open or shorted coil. Replace solenoid coil.
Unit will not go into defrost (heating only)	Temperature sensor or heat pump control defective	Disconnect temperature sensor from board and jumper across "SPEEDUP" terminals and "SEN JMP" terminals. This should cause the unit to go through a defrost cycle within one minute. 1. If unit goes through defrost cycle, replace temperature sensor. 2. If unit does not go through defrost cycle, replace heat pump control.
Unit will not come out of defrost (heating only)	Temperature sensor or heat pump control defective.	Jumper across "SPEEDUP" terminal. This should cause the unit to come out of defrost within one minute. 1. If unit comes out of defrost cycle, replace temperature sensor. 2. If unit does not come out of defrost cycle, replace heat pump control.

CHECKING TEMPERATURE SENSOR OUTSIDE UNIT CIRCUIT

1. Disconnect temperature sensor from board and from outdoor coil.
2. Use an ohmmeter and measure the resistance of the sensor. Also use ohmmeter to check for short or open.
3. Check resistance reading to chart of resistance use sensor ambient temperature. (Tolerance of part is $\pm 10\%$)
4. If sensor resistance reads very low, then sensor is shorted and will not allow proper operation of the heat pump control.
5. If sensor is out of tolerance, shorted, open, or reads very low ohms then it should be replaced.

TEMPERATURE F VS RESISTANCE R OF TEMPERATURE

F	R	F	R	F	R
-25.0	196871	25.0	39898	75.0	10501
-24.0	190099	26.0	38757	76.0	10247
-23.0	183585	27.0	37652	77.0	10000
-22.0	177318	28.0	36583	78.0	9760
-21.0	171289	29.0	35548	79.0	9526
-20.0	165487	30.0	34545	80.0	9299
-19.0	159904	31.0	33574	81.0	9077
-18.0	154529	32.0	32634	82.0	8862
-17.0	149355	33.0	31723	83.0	8653
-16.0	144374	34.0	30840	84.0	8449
-15.0	139576	35.0	29986	85.0	8250
-14.0	134956	36.0	29157	86.0	8057
-13.0	130506	37.0	28355	87.0	7869
-12.0	126219	38.0	27577	88.0	7686
-11.0	122089	39.0	26823	89.0	7507
-10.0	118108	40.0	26092	90.0	7334
-9.0	114272	41.0	25383	91.0	7165
-8.0	110575	42.0	24696	92.0	7000
-7.0	107010	43.0	24030	93.0	6840
-6.0	103574	44.0	23384	94.0	6683
-5.0	100260	45.0	22758	95.0	6531
-4.0	97064	46.0	22150	96.0	6383
-3.0	93981	47.0	21561	97.0	6239
-2.0	91008	48.0	20989	98.0	6098
-1.0	88139	49.0	20435	99.0	5961
0.0	85371	50.0	19896	100.0	5827
1.0	82699	51.0	19374	101.0	5697
2.0	80121	52.0	18867	102.0	5570
3.0	77632	53.0	18375	103.0	5446
4.0	75230	54.0	17898	104.0	5326
5.0	72910	55.0	17434	105.0	5208
6.0	70670	56.0	16984	106.0	5094
7.0	68507	57.0	16547	107.0	4982
8.0	66418	58.0	16122	108.0	4873
9.0	64399	59.0	15710	109.0	4767
10.0	62449	60.0	15310	110.0	4663
11.0	60565	61.0	14921	111.0	4562
12.0	58745	62.0	14544	112.0	4464
13.0	56985	63.0	14177	113.0	4367
14.0	55284	64.0	13820	114.0	4274
15.0	53640	65.0	13474	115.0	4182
16.0	52051	66.0	13137	116.0	4093
17.0	50514	67.0	12810	117.0	4006
18.0	49028	68.0	12492	118.0	3921
19.0	47590	69.0	12183	119.0	3838
20.0	46200	70.0	11883	120.0	3757
21.0	44855	71.0	11591	121.0	3678
22.0	43554	72.0	11307	122.0	3601
23.0	42295	73.0	11031	123.0	3526
24.0	41077	74.0	10762	124.0	3452

COMPRESSOR SOLENOID

A nominal 24-volt direct current coil activates the internal compressor solenoid. The input control circuit voltage must be 18 to 28 volt ac. The coil power requirement is 20 VA. The external electrical connection is made with a molded plug assembly (PN 029-0311-00). This plug contains a full wave rectifier to supply direct current to the unloader coil.

Compressor Solenoid Test Procedure – If it is suspected that the unloader is not working, the following methods may be used to verify operation.

1. Operate the system and measure compressor amperage. Cycle the compressor solenoid on and off at ten-second intervals. The compressor amperage should go up or down at least 25 percent.
2. If step one does not give the expected results, shut unit off. Apply 18 to 28 volt ac to the solenoid molded plug leads and listen for a click as the solenoid pulls in. Remove power and listen for another click as the solenoid returns to its original position.
3. If clicks can't be heard, shut off power and remove the control circuit molded plug from the compressor and measure the solenoid coil resistance. The resistance should be 32 to 60 ohms depending on compressor temperature.
4. Next, check the molded plug.

Voltage check: Apply control voltage to the plug wires (18 to 28 volt ac). The measured **dc** voltage at the female connectors in the plug should be around 15 to 27 vdc.

Resistance check: Measure the resistance from the end of one molded plug lead to either of the two female connectors in the plug. One of the connectors should read close to zero ohms, while the other should read infinity. Repeat with other wire. The same female connector as before should read zero, while the other connector again reads infinity. Reverse polarity on the ohmmeter leads and repeat. The female connector that read infinity previously should now read close to zero ohms.

Replace plug if either of these test methods does not show the desired results.

FAN BLADE SETTING DIMENSIONS

Shown in Figure 13 are the correct fan blade setting dimensions for proper air delivery across the outdoor coil.

Any service work requiring removal or adjustment in the fan and/or motor area will require that the dimensions below be checked and blade adjusted in or out on the motor shaft accordingly.

**FIGURE 13
FAN BLADE SETTING**

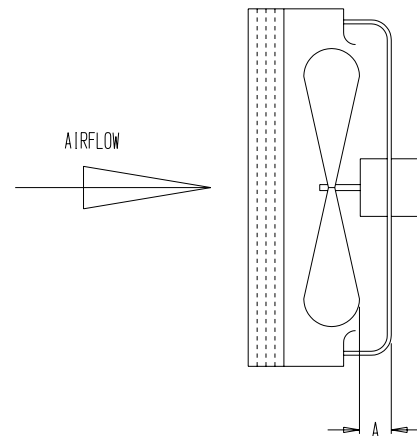

MIS-1272

**TABLE 5
FAN BLADE DIMENSION**

Model	Dimension A
ALL	1.0"

REMOVAL OF FAN SHROUD

1. Disconnect all power to the unit.
2. Remove the screws holding both grilles, one on each side of unit, and remove grilles.
3. Remove screws holding fan shroud to condenser and bottom. Nine (9) screws.
4. Unwire condenser fan motor.
5. Slide complete motor, fan blade, and shroud assembly out the left side of the unit.
6. Service motor/fan as needed.
7. Reverse steps to reinstall.

R-410A

REFRIGERANT CHARGE

This unit was charged at the factory with the quantity of refrigerant listed on the serial plate. AHRI capacity and efficiency ratings were determined by testing with this refrigerant charge quantity.

The following pressure tables show nominal pressures for the units. Since many installation specific situations can affect the pressure readings, this information should only be used by certified technicians as a guide for evaluating proper system performance. They shall not be used to adjust charge. If charge is in doubt, reclaim, evacuate and recharge the unit to the serial plate charge.

**TABLE 6
INDOOR BLOWER PERFORMANCE**

Model	Rated ESP	① Max ESP	② 2nd Stage Cooling 2nd Stage Heating	③ 1st Stage Cooling 1st Stage Heating	④ Blower Only or Vent Mode	Electric Heat
CH3S1	.15	.5	1100	800	800	1100
CH4S1	.2	.5	1500	1100	850	1700
CH5S1	.2	.5	1700	1300	850	1700

NOTE: These units are equipped with a variable speed (ECM) indoor motor that automatically adjusts itself to maintain approximately the same rate of indoor airflow in both heating and cooling, dry and wet coil conditions and at both 230/208 or 460 volts.

- ① Maximum ESP (inches WC) shown is with 2" thick disposable filter.
- ② Rated CFM for 2nd Stage Operation – required for maximum performance rating.
- ③ 1st Stage – the CFM output on 1st Stage Heating or Cooling.
- ④ Blower only CFM is the total air being circulated during continuous fan mode.

**TABLE 7
MAXIMUM ESP OF OPERATION**

	High Speed
ALL	.5

**TABLE 8
PRESSURE TABLE**

HIGH CAPACITY COOLING			AIR TEMPERATURE ENTERING OUTDOOR COIL DEGREE F								
MODEL	RETURN AIR TEMPERATURE	PRESSURE	75°F	80°F	85°F	90°F	95°F	100°F	105°F	110°F	115°F
CH3S1	75° DB 62° WB	LOW SIDE HIGH SIDE	134 298	134 318	134 339	135 363	137 388	138 415	140 445	143 476	146 510
	80° DB 67° WB	LOW SIDE HIGH SIDE	143 306	143 326	143 348	144 372	152 402	148 426	150 456	153 488	156 523
	85° DB 72° WB	LOW SIDE HIGH SIDE	148 317	148 337	148 360	149 385	151 412	153 441	155 472	158 505	161 541
CH4S1	75° DB 62° WB	LOW SIDE HIGH SIDE	131 308	133 332	135 356	137 380	138 406	139 431	139 456	140 483	140 509
	80° DB 67° WB	LOW SIDE HIGH SIDE	140 316	142 340	144 365	146 390	147 416	149 442	149 468	150 495	150 522
	85° DB 72° WB	LOW SIDE HIGH SIDE	145 327	147 352	149 378	151 404	153 431	154 457	154 484	155 512	155 540
CH5S1	75° DB 62° WB	LOW SIDE HIGH SIDE	130 336	131 359	131 381	132 406	134 430	135 455	137 482	138 510	140 538
	80° DB 67° WB	LOW SIDE HIGH SIDE	139 345	140 368	140 391	141 416	143 441	144 467	146 494	148 523	150 552
	85° DB 72° WB	LOW SIDE HIGH SIDE	144 357	145 381	145 405	146 431	148 456	149 483	151 511	153 541	155 571

Low side pressure ± 2 PSIG

High side pressure ± 5 PSIG

Tables are based upon rated CFM (airflow) across the evaporator coil. If there is any doubt as to correct operating charge being in the system, the charge should be removed, system evacuated and recharged to serial plate instruction.

**TABLE 9
PRESSURE TABLE**

LOW CAPACITY COOLING			AIR TEMPERATURE ENTERING OUTDOOR COIL DEGREE F								
MODEL	RETURN AIR TEMPERATURE	PRESSURE	75°F	80°F	85°F	90°F	95°F	100°F	105°F	110°F	115°F
CH3S1	75° DB 62° WB	LOW SIDE HIGH SIDE	139 259	140 284	141 308	142 333	143 359	145 385	147 410	149 438	151 464
	80° DB 67° WB	LOW SIDE HIGH SIDE	149 266	150 291	151 316	152 342	157 370	155 395	157 421	159 449	161 476
	85° DB 72° WB	LOW SIDE HIGH SIDE	154 275	155 301	156 327	157 354	158 381	160 409	162 436	165 465	167 493
CH4S1	75° DB 62° WB	LOW SIDE HIGH SIDE	137 281	137 301	139 323	140 345	141 370	143 394	144 419	146 447	147 475
	80° DB 67° WB	LOW SIDE HIGH SIDE	146 288	147 309	149 331	150 354	151 379	153 404	154 430	156 458	157 487
	85° DB 72° WB	LOW SIDE HIGH SIDE	151 298	152 320	154 343	155 366	156 392	158 418	159 445	161 474	162 504
CH5S1	75° DB 62° WB	LOW SIDE HIGH SIDE	136 293	137 316	139 340	141 364	142 389	143 413	144 439	145 464	145 489
	80° DB 67° WB	LOW SIDE HIGH SIDE	145 300	147 324	149 349	151 373	150 391	153 424	154 450	155 476	155 502
	85° DB 72° WB	LOW SIDE HIGH SIDE	150 311	152 335	154 361	156 386	157 413	158 439	159 466	160 493	160 520

Low side pressure ± 2 PSIG

High side pressure ± 5 PSIG

Tables are based upon rated CFM (airflow) across the evaporator coil. If there is any doubt as to correct operating charge being in the system, the charge should be removed, system evacuated and recharged to serial plate instruction.

**TABLE 10
PRESSURE TABLE**

HIGH CAPACITY HEATING		AIR TEMPERATURE ENTERING OUTDOOR COIL DEGREE F														
MODEL	RETURN AIR TEMPERATURE	PRESSURE	0°F	5°F	10°F	15°F	20°F	25°F	30°F	35°F	40°F	45°F	50°F	55°F	60°F	65°F
CH3S	70°	LOW SIDE	44	46	50	54	59	64	71	78	86	95	105	116	127	139
		HIGH SIDE	290	295	300	303	304	309	318	330	346	364	387	413	442	475
CH4S	70°	LOW SIDE	54	55	56	56	57	61	66	74	83	94	108	123	141	160
		HIGH SIDE	280	281	283	284	288	294	304	317	334	353	376	402	431	463
CH5S	70°	LOW SIDE	44	46	49	53	57	63	68	75	82	90	99	108	119	129
		HIGH SIDE	272	277	284	293	304	316	330	346	364	383	404	427	452	478

Low side pressure ± 2 PSIG

High side pressure ± 5 PSIG

Tables are based upon rated CFM (airflow) across the evaporator coil. If there is any doubt as to correct operating charge being in the system, the charge should be removed, system evacuated and recharged to serial plate instruction.

**TABLE 11
PRESSURE TABLE**

LOW CAPACITY HEATING		AIR TEMPERATURE ENTERING OUTDOOR COIL DEGREE F														
MODEL	RETURN AIR TEMPERATURE	PRESSURE	0°F	5°F	10°F	15°F	20°F	25°F	30°F	35°F	40°F	45°F	50°F	55°F	60°F	65°F
CH3S	70°	LOW SIDE	46	49	53	57	62	68	75	83	91	101	111	122	134	146
		HIGH SIDE	275	280	283	283	286	291	298	308	320	334	350	369	389	412
CH4S	70°	LOW SIDE	60	65	63	61	62	64	70	77	87	99	113	130	149	170
		HIGH SIDE	270	271	271	273	278	284	293	303	316	331	348	367	388	411
CH5S	70°	LOW SIDE	58	56	56	58	60	64	70	77	85	95	106	119	133	148
		HIGH SIDE	275	274	275	279	285	294	306	321	338	358	381	406	434	465

Low side pressure ± 2 PSIG

High side pressure ± 5 PSIG

Tables are based upon rated CFM (airflow) across the evaporator coil. If there is any doubt as to correct operating charge being in the system, the charge should be removed, system evacuated and recharged to serial plate instruction.

Troubleshooting GE ECM™ Motors

CAUTION:

Disconnect power from unit before removing or replacing connectors, or servicing motor. To avoid electric shock from the motor's capacitors, disconnect power and wait at least 5 minutes before opening motor.

Symptom

Motor rocks slightly when starting

Cause/Procedure

- This is normal start-up for ECM

Motor won't start
• No movement

- Check blower turns by hand
- Check power at motor
- Check low voltage (24 Vac R to C) at motor
- Check low voltage connections (G, Y, W, R, C) at motor
- Check for unseated pins in connectors on motor harness
- Test with a temporary jumper between R - G
- Check motor for tight shaft
- Perform motor/control replacement check
- **Perform Moisture Check**

• Motor rocks, but won't start

- Check for loose or compliant motor mount
- Make sure blower wheel is tight on shaft
- Perform motor/control replacement check

Motor oscillates up & down while being tested off of blower

- It is normal for motor to oscillate with no load on shaft

Motor starts, but runs erratically

• Varies up and down or intermittent

- Check line voltage for variation or "sag"
- Check low voltage connections (G, Y, W, R, C) at motor, unseated pins in motor harness connectors
- Check "Bk" for erratic CFM command (in variable-speed applications)
- Check out system controls, Thermostat
- **Perform Moisture Check**

• "Hunts" or "puffs" at high CFM (speed)

- Does removing panel or filter reduce "puffing"?
 - Reduce restriction
 - Reduce max airflow

• Stays at low CFM despite system call for cool or heat CFM

- Check low voltage (Thermostat) wires and connections
- Verify fan is not in delay mode; wait until delay complete
- "R" missing/not connected at motor
- Perform motor/control replacement check

• Stays at high CFM

- "R" missing/not connected at motor
- Is fan in delay mode? - wait until delay time complete
- Perform motor/control replacement check

• Blower won't shut off

- Current leakage from controls into G, Y or W? Check for Triac switched thermostat or solid-state relay

Excessive noise

• Air noise

- Determine if it's air noise, cabinet, duct or motor noise; interview customer, if necessary
- High static creating high blower speed?
 - Is airflow set properly?
 - Does removing filter cause blower to slow down? Check filter
 - Use low-pressure drop filter
 - Check/correct duct restrictions

Symptom

• Noisy blower or cabinet

Cause/Procedure

- Check for loose blower housing, panels, etc.
- High static creating high blower speed?
 - Check for air whistling through seams in ducts, cabinets or panels
 - Check for cabinet/duct deformation

• "Hunts" or "puffs" at high CFM (speed)

- Does removing panel or filter reduce "puffing"?
 - Reduce restriction
 - Reduce max. airflow

Evidence of Moisture

• Motor failure or malfunction has occurred and moisture is present

- Replace motor and **Perform Moisture Check**

• Evidence of moisture present inside air mover

- **Perform Moisture Check**

Do

• Check out motor, controls, wiring and connections thoroughly before replacing motor

Don't

• Automatically assume the motor is bad.

• Orient connectors down so water can't get in
- Install "drip loops"

• Locate connectors above 7 and 4 o'clock positions

• Use authorized motor and model #'s for replacement

• Replace one motor or control model # with another (unless an authorized replacement)

• Keep static pressure to a minimum:

• Use high pressure drop filters some have ½" H2O drop!

- Recommend high efficiency, low static filters
- Recommend keeping filters clean.

• Use restricted returns

- Design ductwork for min. static, max. comfort

- Look for and recommend ductwork improvement, where necessary

• Size the equipment wisely

• Oversize system, then compensate with low airflow

• Check orientation before inserting motor connectors

• Plug in power connector backwards
• Force plugs

Moisture Check

• Connectors are oriented "down" (or as recommended by equipment manufacturer)

• Arrange harness with "drip loop" under motor

• Is condensate drain plugged?

• Check for low airflow (too much latent capacity)

• Check for undercharged condition

• Check and plug leaks in return ducts, cabinet

Comfort Check

• Check proper airflow settings

• Low static pressure for lowest noise

• Set low continuous-fan CFM

• Use humidistat and 2-speed cooling units

• Use zoning controls designed for ECM that regulate CFM

• Thermostat in bad location?

Troubleshooting GE ECM™ Motors (Cont'd.)

Replacing ECM Control Module

To replace the control module for the GE variable-speed indoor blower motor you need to take the following steps:

1. You **MUST** have the correct replacement module. The controls are factory programmed for specific operating modes. Even though they look alike, different modules may have completely different functionality.

USING THE WRONG CONTROL MODULE VOIDS ALL PRODUCT WARRANTIES AND MAY PRODUCE UNEXPECTED RESULTS.

2. Begin by removing AC power from the unit being serviced. **DO NOT WORK ON THE MOTOR WITH AC POWER APPLIED.** To avoid electric shock from the motor's capacitors, disconnect power and wait at least 5 minutes before opening motor.

3. It is not necessary to remove the motor from the blower assembly, nor the blower assembly from the unit. Unplug the two cable connectors to the motor control assembly. There are latches on each connector. **DO NOT PULL ON THE WIRES.** The plugs remove easily when properly released.

4. Locate the screws that retain to the motor control bracket to the sheet metal of the unit and remove them. Remove two (2) nuts that retain the control to the bracket and then remove two (2) nuts that retain sheet metal motor control end plate. Refer to Figure 14.

5. Disconnect the three (3) wires interior of the motor control by using your thumb and forefinger squeezing the latch tab and the opposite side of the connector plug, gently pulling the connector. **DO NOT PULL ON THE WIRES, GRIP THE PLUG ONLY.** Refer to Figure 14.

6. The control module is now completely detached from the motor. Verify with a standard ohmmeter that the resistance from each motor lead (in the motor plug just removed) to the motor shell is $>100\text{K}$ ohms. Refer to Figure 15. (Measure to unpainted motor end plate.) If any motor lead fails this test, do not proceed to install the control module. **THE MOTOR IS DEFECTIVE AND MUST BE REPLACED.** Installing the new control module will cause it to fail also.

7. Verify that the replacement control is correct for your application. Refer to the manufacturer's authorized replacement list. **USING THE WRONG CONTROL WILL RESULT IN IMPROPER OR NO BLOWER OPERATION.** Orient the control module so that the 3-wire motor plug can be inserted into the socket in the control. Carefully insert the plug and press it into the socket until it latches. **A SLIGHT CLICK WILL BE HEARD WHEN PROPERLY INSERTED.**

8. Reverse the steps #5, 4, 3 to reconnect the motor control to the motor wires, securing the motor control cover plate, mounting the control to the bracket, and mounting the motor control bracket back into the unit. **MAKE SURE THE ORIENTATION YOU SELECT FOR REPLACING THE CONTROL ASSURES THE CONTROL'S CABLE CONNECTORS WILL BE LOCATED DOWNWARD IN THE APPLICATION SO THAT WATER CANNOT RUN DOWN THE CABLES AND INTO THE CONTROL. DO NOT OVERTIGHTEN THE BOLTS.**

9. Plug the 16-pin control plug into the motor. The plug is keyed. Make sure the connector is properly seated and latched.

10. Plug the 5-pin power connector into the motor. Even though the plug is keyed, **OBSERVE THE PROPER ORIENTATION. DO NOT FORCE THE CONNECTOR.** It plugs in very easily when properly oriented. **REVERSING THIS PLUG WILL CAUSE IMMEDIATE FAILURE OF THE CONTROL MODULE.**

11. Final installation check. Make sure the motor is installed as follows:

- Motor connectors should be oriented between the 4 o'clock and 8 o'clock positions when the control is positioned in its final location and orientation.
- Add a drip loop to the cables so that water cannot enter the motor by draining down the cables. Refer to Figure 16.

The installation is now complete. Reapply the AC power to the HVAC equipment and verify that the new motor control module is working properly. Follow the manufacturer's procedures for disposition of the old control module.

