INSTALLATION INSTRUCTIONS

SINGLE PACKAGE HEAT PUMPS

MODELS

PH13241-A	PH13301-A
PH13361-A	PH13361-B
PH13421-A	PH13421-B
PH13481-A	PH13481-B
PH13601-A	PH13601-B



Bard Manufacturing Company, Inc.
Bryan, Ohio 43506
Since 1914 . . . Moving ahead, just as planned.

Manual : 2100-468A
Supersedes: 2100-468
File: Volume II Tab 11
Date: 06-23-06

CONTENTS

Getting Other Informations and Publications

General Instructions

Important	3
Shipping Damage	4
General	4
Field-Installed Heater Packages (Optional)	4

Installation

Location	9
Slab Mounting	9
Winter Installation	9
Typical Installations	9 & 12
Condensate Drain Trap	12
Air Filters	12
Thermostats	13
Wiring – Main Power	14
Wiring – 24V Low Voltage Control Circuit	14
Thermostat Indicator Lamps	15
Emergency Heat Position	15
Transformer Taps	15
Compressor Cutoff Thermostat and Outdoor	

Figures

Figure 1 Unit Dimensional Drawing	8
Figure 2 Slab Mounting at Ground Level	10
Figure 3 Airflow and Service Access Clearances	10
Figure 4 Elevated Mounting Platform	11
Figure 5 Condensate Drain Trap	12
Figure 6 Low Voltage Wiring	14
Figure 7 Unit 24V Terminal Board (5–10 KW)	15
Figure 8 Unit 24V Terminal Board (15–20 KW) ...	16
Figure 9 Heat Pump Control Board	19
Figure 10 Fan Blade Setting	22
Figure 11 Brazing Diagram	23
Figure 12 Control Disassembly	25
Figure 13 Winding Test	25
Figure 14 Drip Loop	25

Start Up and Operation

General	17
Topping Off System Charge	17
Safety Practices	17
Start Up Notes	17
Three Phase Scroll Compressor Start Up Information	18
Sequence of Operation	18
Defrost Cycle	19

Troubleshooting

Solid State Heat Pump Control Troubleshooting Procedure	20
Troubleshooting Guide	20
Checking Temperature Sensor Check Out	21
Temperature vs. Resistance of Temperature Sensor Chart	21

Service

Service Hints	22
Pressure Service Ports	22
Refrigerant Charge	22
Fan Blade Settings	22
Suction and Discharge Tube Brazing	23

Troubleshooting GE ECM Blower Motors . 24 & 25

Pressure Tables	26 & 27
-----------------------	---------

Tables

Table 1 Rated CFM and ESP	4
Table 2 Electrical Data	5
Table 3 Optional Field Installed Heater Packages	6
Table 4 Opt. Field Installed Elec. Heater	7
Table 5 Required Filters	12
Table 6 Heat Pump Thermostats	13
Table 7 Thermostat Wire Size	13
Table 8 Compressor Cutoff Thermostat Wiring (5 - 10 KW)	16
Table 9 Compressor Cutoff Thermostat Wiring (15 - 20 KW)	16
Table 10 Refrigerant Charge	22
Table 11 Fan Blade Setting Dimensions	22
Table 12 Indoor Blower Performance	23
Table 13 Pressure Table - Cooling	26
Table 14 Pressure Table - Heating	27

Getting Other Information and Publications

These publications can help you install the air conditioner or heat pump. You can usually find these at your local library or purchase them directly from the publisher. Be sure to consult current edition of each standard.

National Electrical Code ANSI/NFPA 70

Standard for the Installation ANSI/NFPA 90A
of Air Conditioning and Ventilating Systems

Standard for Warm Air ANSI/NFPA 90B
Heating and Air Conditioning Systems

Load Calculation for ACCA Manual J
Residential Winter and Summer Air Conditioning

Duct Design for Residential ACCA Manual D
Winter and Summer Air Conditioning and Equipment
Selection

FOR MORE INFORMATION, CONTACT THESE PUBLISHERS:

ACCA **Air Conditioning Contractors of America**
1712 New Hampshire Ave. N.W.
Washington, DC 20009
Telephone: (202) 483-9370
Fax: (202) 234-4721

ANSI **American National Standards Institute**
11 West Street, 13th Floor
New York, NY 10036
Telephone: (212) 642-4900
Fax: (212) 302-1286

ASHRAE **American Society of Heating Refrigerating,
and Air Conditioning Engineers, Inc.**
1791 Tullie Circle, N.E.
Atlanta, GA 30329-2305
Telephone: (404) 636-8400
Fax: (404) 321-5478

NFPA **National Fire Protection Association**
Batterymarch Park
P.O. Box 9101
Quincy, MA 02269-9901
Telephone: (800) 344-3555
Fax: (617) 984-7057

GENERAL INSTRUCTIONS

IMPORTANT

The equipment covered in this manual is to be installed by trained, experienced service and installation technicians. Any heat pump is more critical of proper operating charge and an adequate duct system than a straight air conditioning unit. All duct work, supply and return ducts, must be properly sized for the design air flow requirement of the equipment. ACCA is an excellent guide to proper sizing. All duct work or portions thereof not in the conditioned space should be properly insulated in order to both conserve energy and prevent condensation or moisture damage.

SHIPPING DAMAGE

Upon receipt of equipment, the carton should be checked for external signs of shipping damage. If damage is found, the receiving party must contact the last carrier immediately, preferably in writing, requesting inspection by the carrier's agent.

GENERAL

The refrigerant system is completely assembled and charged. All internal wiring is complete.

The unit is designed for use with or without duct work. Flanges are provided for attaching the supply and return ducts.

These instructions explain the recommended method to install the air cooled self-contained unit and the electrical wiring connections to the unit.

These instructions and any instructions packaged with any separate equipment required to make up the entire heat pump system should be carefully read before beginning the installation. Note particularly "Starting Procedure" and any tags and/or labels attached to the equipment.

While these instructions are intended as a general recommended guide, they do not supersede any national and/or local codes in any way. Authorities having jurisdiction should be consulted before the installation is made.

FIELD INSTALLED HEATER PACKAGES (OPTIONAL)

These packaged heat pumps are manufactured without supplementary electric heaters. Supplementary heaters are available for simple, fast field installation.

A separate power circuit is required for the supplementary heaters.

IMPORTANT: Refer to Table 1 when designing duct work for maximum available static pressure with heater installed.

Refer to Tables 2 and 4 for proper application information on all available heater combinations and what units they can be used with. It also shows the applicable circuit ampacities, fuse size, and wire size for each heater combination.

**TABLE 1
RATED CFM AND EXTERNAL STATIC PRESSURE (ESP)**

Model	Rated CFM	Recommended Airflow Range	Rated ESP	Maximum ESP
PH1324	800	Note	0.10	0.50
PH1330	1000	Note	0.15	0.50
PH1336	1100	Note	0.15	0.50
PH1342	1400	Note	0.15	0.50
PH1348	1550	Note	0.20	0.50
PH1360	1800	Note	0.20	0.50

NOTE: Motor will adjust to deliver rated airflow.

**TABLE 2
ELECTRICAL DATA**

Model	PH13241-A	PH13301-A	PH13361-A	PH13361-B	PH13421-A	PH13421-B	PH13481-A	PH13481-B	PH13601-A	PH13601-B
Electric Rating 60 Hz - Ckt A	230/208-60-1	230/208-60-1	230/208-60-1	230/208-60-3	230/208-60-1	230/208-60-3	230/208-60-1	230/208-60-3	230/208-60-1	230/208-60-3
Operating Voltage Range	197-253	197-253	197-253	187-253	197-253	187-253	197-253	187-253	197-253	187-253
Minimum Circuit Ampacity	20	22	27	18	33	25	36	29		
BCSC	13	14	17.5	11	21	15	22	14		
Field Wire Size *	12	10	10	12	10	10	8	10		
Ground Wire Size	12	10	8	12	10	10	8	10		
Delay Fuse - Max. **	30	30	40	25	50	35	50	40		
Total Unit Amps - 203-208	11.2/12.2	14.8/16.3	19.4/21.9	13.9/15.4	21.9/22.9	17.1/17.9	24.7/26.6	18.0/19.2		
Compressor - Circuit A										
Compressor Type	Scroll	Scroll	Scroll	Scroll	Scroll	Scroll	Scroll	Scroll	Scroll	Scroll
Volts	230/208	230/208	230/208	230/208	230/208	230/208	230/208	230/208	230/208	230/208
Rated Load Amps	8/9	11/12.5	15/17.5	9.5/11	16.1/17.1	11.3/12.0	18.7/20.6	12.0/13.2		
Lock Rotor Amps	58.3/58.3	73/73	79/79	88/88	115/115	115/115	117/117	83.1/83.1		
Fan Motor and Condenser										
Fan Motor - HP/RPM	1/6 / 825	1/6 / 825	1/6 / 825	1/6 / 825	1/4 / 825	1/4 / 825	1/4 / 825	1/4 / 825	1/4 / 825	1/4 / 825
Fan Motor Amps	1.1	1.1	1.1	1.1	1.5	1.5	1.5	1.5	1.5	1.5
Fan Dia/CFM	24"/2800	24"/2600	24"2600	24"/2600	24"/3400	24"/3400	24"/3400	24"/3400	24"/3400	24"/3400
Motor and Evaporator										
Blower Motor - HP/RPM	1/3 Variable	1/2 Variable	1/2 Variable	1/2 Variable	1/2 Variable	1/2 Variable	3/4 Variable	3/4 Variable	3/4 Variable	3/4 Variable
Blower Motor - Amps	2.1	2.7	3.3	3.3	4.3	4.3	4.5	4.5	4.7	4.7
CFM Cooling & ESP	800 @ 0.18	1000 @ 0.23	1000 @ 0.23	1000 @ 0.23	1400 @ 0.23	1400 @ 0.23	1550 @ 0.28	1550 @ 0.28	1700 @ 0.28	1700 @ 0.28
Charge (R-410A oz.)	75	136	136	136	170	170	180	180		
Shipping Weight (pounds)	365	365	365	365						

* 75 degree C copper wire

** Maximum time delay fuse of HACR type circuit breaker

**TABLE 3
OPTIONAL FIELD INSTALLED HEATER PACKAGES
ONLY TO BE USED WITH THE HEAT PUMP MODELS INDICATED**

Heater Package Model	Volts and Phase	PH13241-A	PH13301-A	PH13361-A	PH13361-B	PH13421-A	PH13421-B	PH13481-A	PH13481-B	PH13601-A	PH13601-B
EHP313-A05	240/208-1	X	X	X							
EHP313-A10	240/208-1	X	X	X							
EHP313-A15	240/208-1		X ①	X ①							
EHP313-B09	240/208-3				X						
EHP313-B15	240/208-3				X ②						
EHP513-A05	240/208-1					X		X		X	
EHP513-A10	240/208-1					X		X		X	
EHP513-A15	240/208-1					X ①		X ①		X ①	
EHP513-B09	240/208-3							A	X	A	X
EHP513-B15	240/208-3							A ②	X ②	A ②	X ②

S = Standard application — heater voltage and phase same as basic unit.

A = Alternate application — heater voltage and phase different from basic unit.

NA = Not approved.

① Max. KW that can operate with Heat Pump on is 10 KW. 15 KW will operate during emergency heat.

② Max. KW that can operate with Heat Pump on is 9 KW. 15 KW will operate during emergency heat.

**TABLE 4
OPTIONAL FIELD INSTALLED ELECTRIC HEATER TABLE**

Heater Pkg. Model No.	Unit Volts & Phases	Heater KW & Capacity @ 240 Volts		Heater KW & Capacity @ 208 Volts		240/208V Heater Amps	Heater Internal Fuse	Circuit B				
		KW	BTUH	KW	BTUH			No. Field Circuits	Min. Circuit Ampacity	Max. Over Current Protection	Field Power Wiring	Ground Wire Size
EHP313-A05	240/208-1	5	17,100	3.75	12,800	20.8/18.1		1	26/23	30/25	10/10	10
EHP313-A10	240/208-1	10	34,100	7.50	26,000	41.6/36.2	30/60	1	53/46	60/50	6/8	10
EHP313-A15	240/208-1	15	51,200	11.25	38,400	62.5/54.1		1	79/68	80/70	4/4	8
EHP513-A05	240/208-1	5	17,100	3.75	12,800	20.8/18.1		1	26/23	30/25	10/10	10
EHP513-A10	240/208-1	10	34,100	7.50	26,000	41.6/36.2	30/60	1	53/46	60/50	6/8	10
EHP513-A15	240/208-1	15	51,200	11.25	38,400	62.5/54.1		1	79/68	80/70	4/4	8
EHP313-B09	240/208-3	9	30,700	6.75	23,000	21.7/18.7	None	1	28/24	30/25	10/10	10
EHP313-B15	240/208-3	15	51,200	11.25	38,400	36.2/31.2		1	46/39	50/40	8/8	10
EHP513-B09	240/208-3	9	30,700	6.75	23,000	21.7/18.7	None	1	28/24	30/25	10/10	10
EHP513-B15	240/208-3	15	51,200	11.25	38,400	36.2/31.2		1	46/39	50/40	8/8	10

① Time delay fuses of HACR type circuit breakers must be used for 60 and smaller sizes. Standard fuses or circuit breakers are suitable for sizes 70 and larger. 480V circuit breakers are not HACR type.

② Based on wire suitable for 75 degree C. Other wiring materials must be rated for marked Minimum Circuit Ampacity or greater.

③ Based upon Table 250-95 of N.E.C. 1993. See electric data for basic heat pump for Circuit A wiring specification requirements.

NOTE: While this electrical data is presented as a guide, it is important to electrically connect properly sized fuses and conductor wires in accordance with the national Electrical Code and all existing local codes.

**FIGURE 1
UNIT DIMENSIONAL DRAWING**

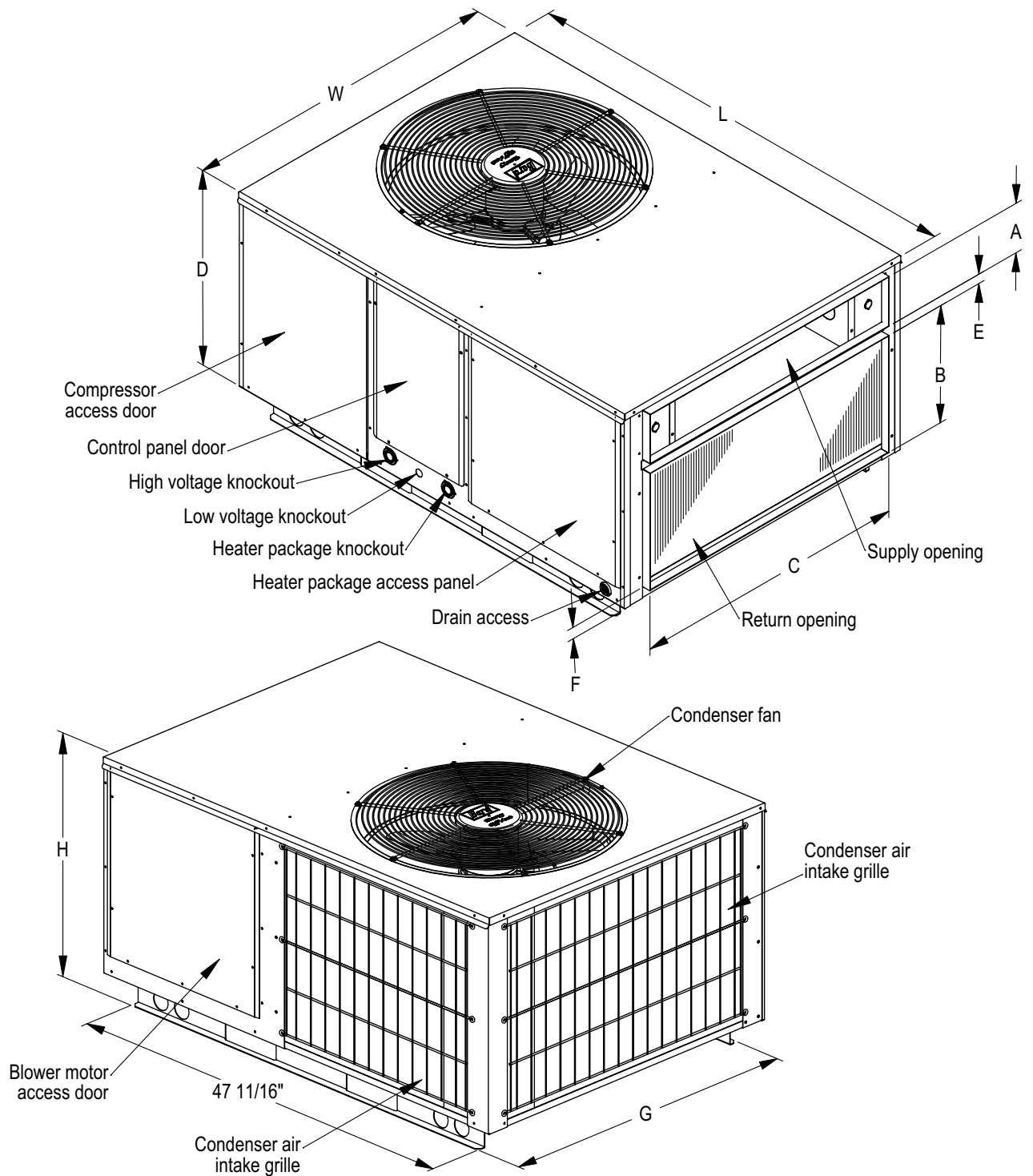

Unit Dimension Chart

Unit	Supply Size		Return Size		Unit Overall Dimensions			Unit General Dimensions			
	A	C	B	C	H (height)	L (length)	W (width)	D	E	F	G
PA/PH1324,1330,1336	5.875	32.875	13.875	32.875	26.25	53.25	38.125	23.25	1.125	1.375	35.625
PA/PH1342,1348,1360	9.875	37.875	15.875	37.875	33.25	55.25	42.375	30.25	1.5	2.375	38.125

MIS-2142

LOCATION

GENERAL

The unit must be located outside, or in a well ventilated area. It must not be in the space being heated or cooled. A sound absorbing material should be considered if the unit is to be installed in such a position or location that might cause transmission of sound or vibration to the living area or adjacent buildings.

SLAB MOUNTING

In areas where winter temperatures *DO NOT* go below 32°F for periods over twelve hours, the unit may be slab mounted at grade level. When installing unit at grade level, install on a concrete slab at least four inches above finished grade level. Slab should have a slope tolerance away from the building structure of at least ¼ inch per foot, while being level from side to side. This will prevent ice buildup under the unit during defrost cycles. Place slab in a location where runoff water from higher ground will not collect around unit. See Figure 2.

A minimum of 24 inches should be provided between the coil inlet and any building surfaces. Provide a minimum of three feet clearance on the service access side of the unit. See Figure 3.

When a unit is installed in areas where low ambient temperatures or strong winter winds exist, it should be placed so prevailing winter winds are not in direct line with the heat pump coil. If this is not possible, a wind barrier should be constructed. Place barrier 24 inches from the coil inlet side of the unit and in the direction of prevailing winds. Size barrier at least the same height and width as the unit. This may be necessary on ground level installations, also. See Figure 3.

WINTER INSTALLATION BELOW 32°F

In areas where winter conditions go below 32°F for extended periods, the unit must be elevated above the mounting surface to prevent snowfall or defrost ice accumulation from interfering with the operation of the unit. A minimum of twelve inch elevation is recommended, while greater elevation may be required for areas of high snow accumulation. Poured concrete, steel framework, brick, cement block, etc., can be utilized to construct a suitable raised mounting platform. See Figure 4.

TYPICAL INSTALLATIONS

1. **ROOF MOUNTED** – The unit is mounted on a sturdy base on the roof of the building. Return air to the unit is brought through a single return grille (grilles with built-in filters are best since they enable easy access for filter changing). Return air ducts are attached to the lower section of the front panel. Supply air is brought from the unit to attic duct work or to a furred down hall. Supply air duct is attached to the top of the front panel.

CAUTION: All outdoor duct work must be thoroughly insulated and weatherproofed. All attic duct work must be thoroughly insulated. Two inch thick insulation with suitable vapor barrier is recommended for both outdoor and attic runs.

In roof top installation, as in all installations, the heat pump must be level from side to side. However, the unit should have a pitch along the length to assure complete external drainage of precipitation and of defrost condensate.

2. **CRAWL SPACE** – Duct work installed in crawl space must be well insulated and provided with a vapor barrier. In addition, the crawl space must be thoroughly ventilated and provided with a good vapor barrier as a ground cover. It is most desirable to install the unit outdoors rather than inside the crawl space, so that it will be readily accessible for service. In addition, it is necessary to dispose of the condensate from the outdoor coil on the heating cycle, and this is virtually impossible with the unit installed inside the crawl space.
3. **SLAB MOUNTED AT GROUND LEVEL** – This type installation is ideal for homes with a slab floor construction where a roof mounted unit is not desired. The supply and return duct work can be run through a furred closet space.
4. **THROUGH THE WALL** – This type installation requires a suitable framework to be fabricated capable of withstanding the unit weight. Normally the unit will be insulated so as to minimize supply and return duct work.

**FIGURE 2
SLAB MOUNTING AT GROUND LEVEL**

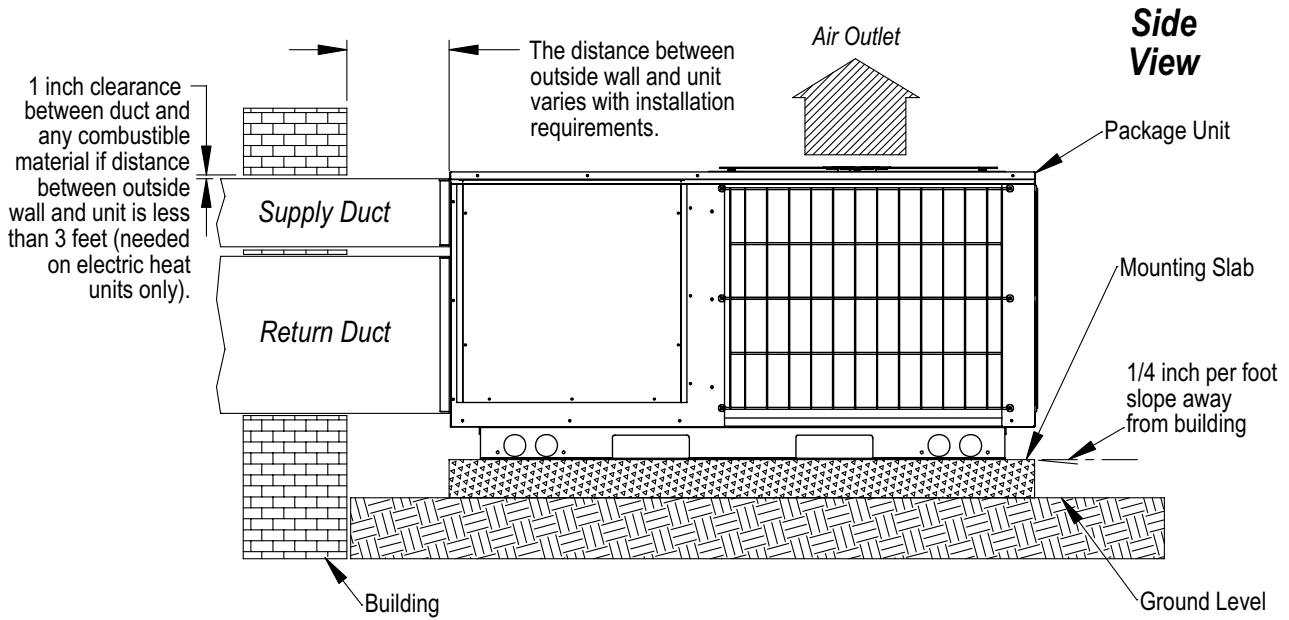

**FIGURE 3
AIRFLOW AND SERVICE ACCESS CLEARANCES**

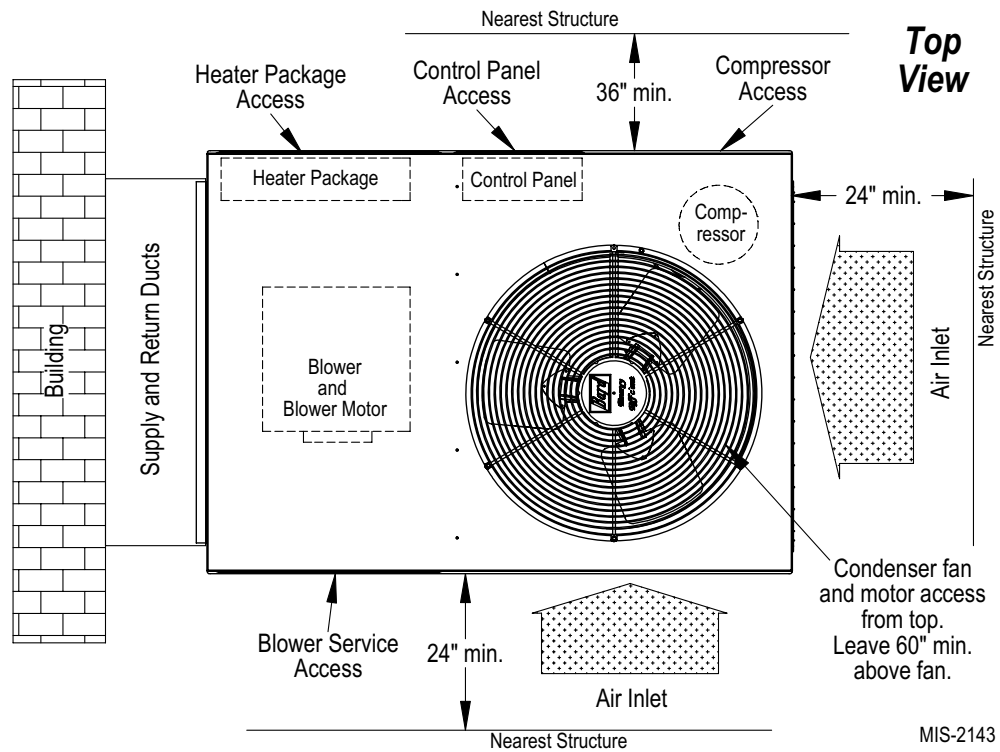

**FIGURE 4
ELEVATED MOUNTING PLATFORMS**

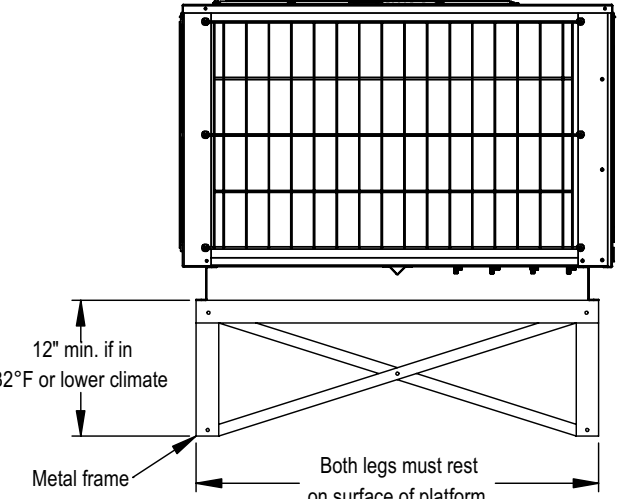
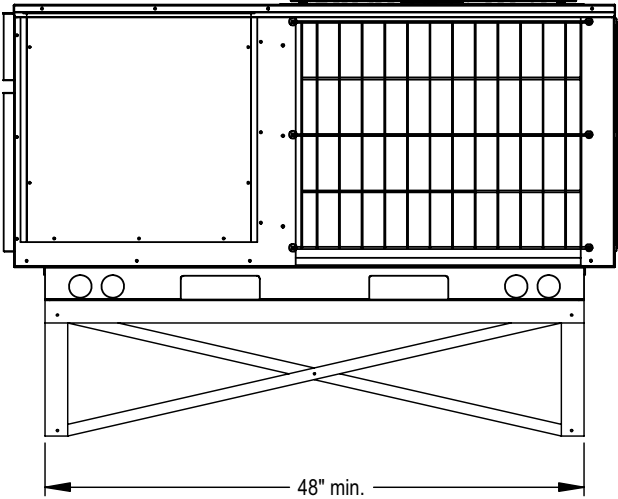
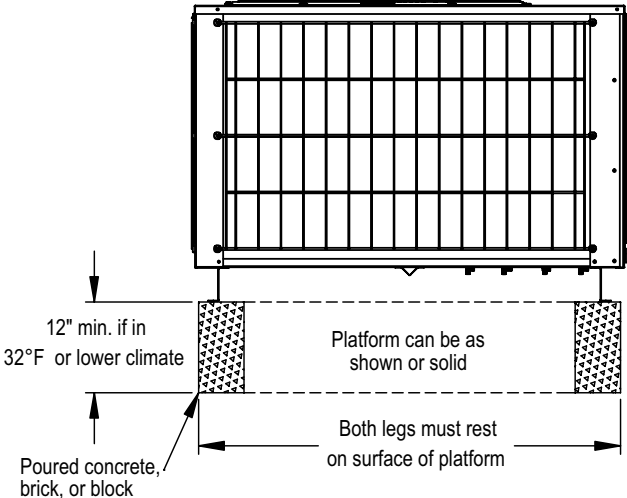
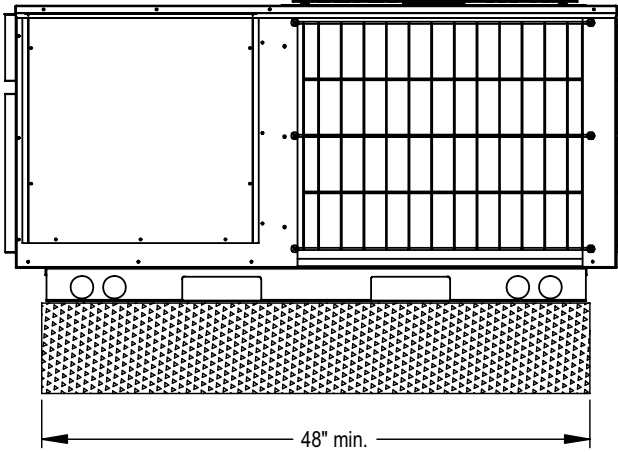

MIS-2144

5. **OTHER INSTALLATIONS** – Many other installations are possible with the packaged heat pump. No matter what the installation, always consider the following facts:
- A. Insure that the discharge air is not obstructed in any way so as to cause operation difficulties.
 - B. The indoor coil drain pan is equipped with a coupling that must be piped through a condensate drain trap to a suitable drain.
 - C. Always mount the unit in such a position that it may be easily reached for servicing and maintenance.
 - D. Insure that the unit is clear so that proper air flow over the outdoor coil will be maintained.

If this unit is operated in cooling below a 55° outdoor ambient temperature, the installation of low ambient controls (CMH-15) to unit is required.

CONDENSATE DRAIN TRAP

It is very important to provide a trap in the condensate drain line to allow a positive liquid seal in the line and assure correct drainage from the coil condensate pan.

Install condensate drain trap shown in Figure 5. Use drain connection size or larger. Do not operate unit without trap. Unit must be level or slightly inclined toward drain.

With a trap installed on a unit located in an unconditioned area, water in the trap may freeze. It is recommended that the trap material be of a type that will allow for expansion of water when it freezes.

AIR FILTERS

Air filters for the return air side of the system are not provided as part of the various types of applications for these models, and must be field supplied and installed as part of the final installation.

Prior thought should be given to return air location and placement of the air filter(s). The air filter(s) must be of adequate size and readily accessible to the operator of the equipment. Filters must be adequate in size and properly maintained for proper operation. If this is not done, excessive energy use, poor performance, and multiple service problems will result. *It is impossible to oversize air filters.* Generous sizing will result in cleaner air and coils as well as lower operating costs and extend the time between required changes. Table 5 shows minimum filter areas and recommended filter sizes. Actual filter sizes can vary with the installation due to single or multiple returns utilizing a filter/grille arrangement or being placed immediately ahead of the indoor coil face in the return air duct.

**TABLE 5
FILTERS REQUIRED AND SIZE**

Model No.	Minimum Filter Area	Recommended Size
PH1324 PH1330 PH1336	462 Square Inches (3.21 Square Feet)	15 x 30-5/8 x 1
PH1342 PH1348 PH1360	608 Square Inches (4.62 Square Feet)	(2) 16 x 20 x 1

NOTE: If roof hood accessory is to be used, information on air filters may be found under that heading in this manual. Air filters are supplied as part of that package.

**FIGURE 5
CONDENSATE DRAIN TRAP**

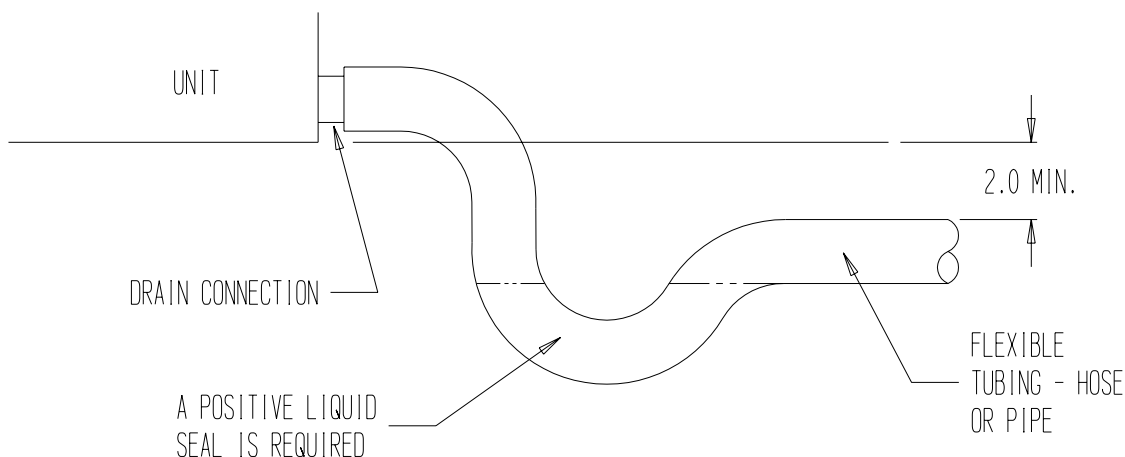

THERMOSTATS

See specific wiring information for the different models, heater KWs, and voltages.

**TABLE 6
HEAT PUMP THERMOSTATS**

THERMOSTAT	SUBBASE	DESCRIPTION
8403-042 (T8511G1070)	Part of Thermostat	1 stage cool, 2 stage heat; Digital non-programmable (no battery required) Automatic or manual changeover Fan Switch: Auto-On; System Switch: Off-Em Heat-Auto or Cool/Heat Indicating Lamps: Check Display Indication: Em Heat-Aux Heat
8403-049 (1F93-380)	Part of Thermostat	2 stage cool, 2 stage heat; Digital programmable (7 day); Automatic or manual changeover; 1 set-up/set-back period per 24 hours Programmable ventilation terminal for economizer or energy recovery Fan Switch: Auto-On; System Switch: Off-Em Heat-Auto or Cool/Heat Indicating Lamps: Emer-Pump-Malf-Aux

IMPORTANT NOTE: Only the thermostat and subbase combinations as shown above will work with this equipment. The thermostat and subbase **MUST** be matched, and correct operation can be assured only by proper selection and application of these parts. The above combinations incorporate the following features: Man-Auto fan switch, Off-Heat-Cool-Em. Heat Switch, and two (2) indicator lamps - one for emergency heat and one for compressor malfunction.

NOTE: All thermostats specified maintain the reversing valve energized when switched into heating mode (does not cycle with demand). This is critical to maintain the HSPF rating of this product.

**TABLE 7
THERMOSTAT WIRE SIZE**

Transformer VA	FLA	Wire Gauge	Maximum Length In Feet
55	2.3	20	45
		18	60
		16	100
		14	160
		12	250

WIRING – MAIN POWER

Refer to the unit rating plate for wire sizing information and maximum fuse size. Each outdoor unit is marked with a “Minimum Circuit Ampacity”. This means that the field wiring used must be sized to carry that amount of current. If field installed heaters are added to the basic unit, a second separate power supply circuit will be required. The heater rating plate located adjacent to the basic unit rating plate will show the appropriate circuit ampacity fuse size, etc. (Also see “Electrical Data” on pages 5 and 7.) *All models are suitable for connection with copper wire only.* These instructions **must** be adhered to. Refer to the National Electrical Code for complete current carrying capacity data on the various insulation grades of wiring material.

The unit rating plate lists a “Maximum Time Delay Fuse” or “HACR” type circuit breaker that is to be used with the equipment. The correct size must be used for proper circuit protection and also to assure that there will be no nuisance tripping due to the momentary high starting current of the compressor.

WIRING – 24V LOW VOLTAGE CONTROL CIRCUIT

Eight (8) wires should be run from thermostat subbase to the 24V terminal board in the unit. A ten conductor, 18 gauge copper, color-coded thermostat cable is recommended. The connection points are shown in Figure 6.

**FIGURE 6
LOW VOLTAGE WIRING**

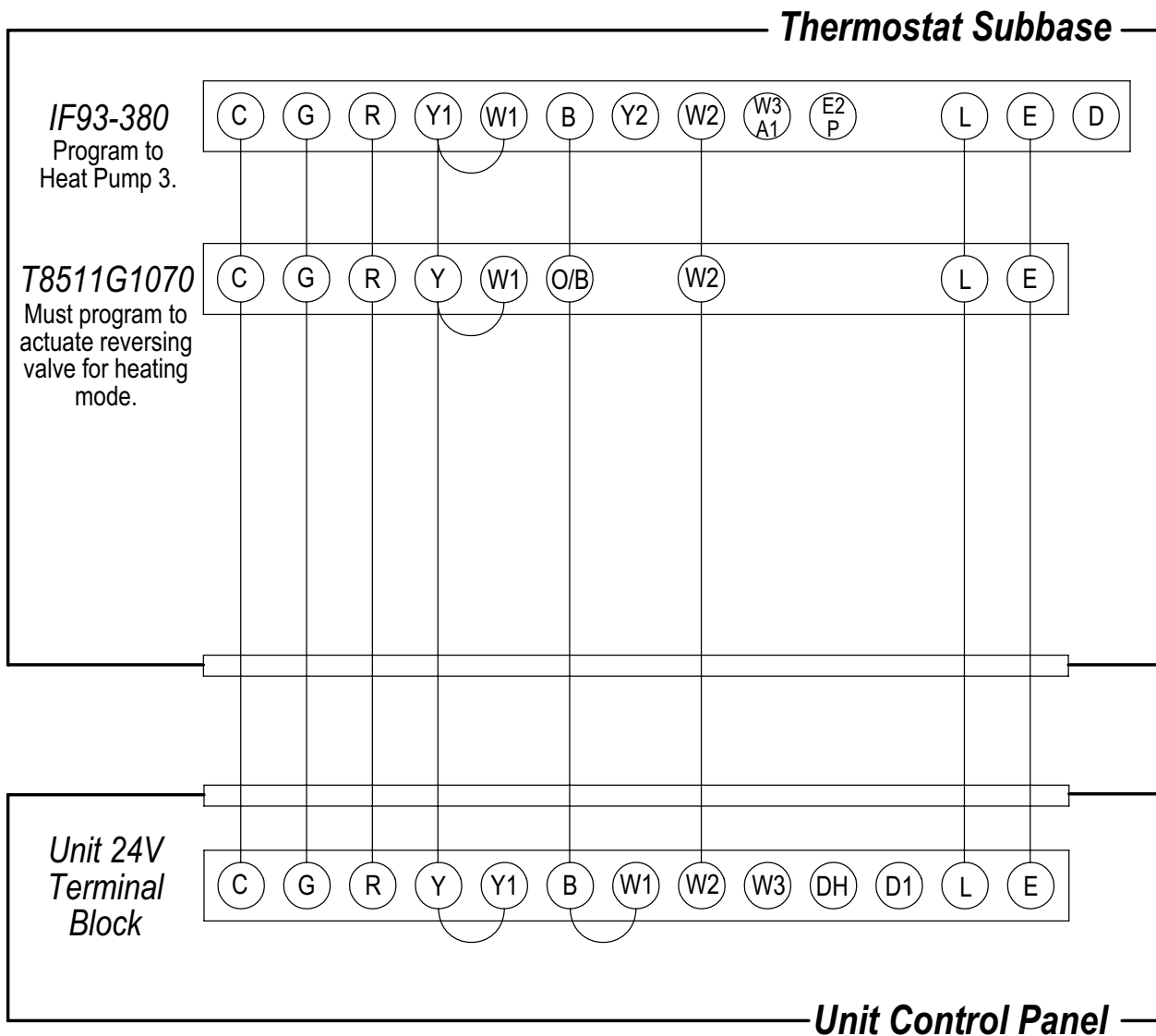

MIS-2150

THERMOSTAT INDICATOR LAMPS

The red lamp marked “EM. HT.” comes on and stays on whenever the system switch is placed in Em. Ht. position. The green lamp marked “Check” will come on if there is any problem that prevents the compressor from running when it is supposed to be.

EMERGENCY HEAT POSITION

The operator of the equipment must manually place the system switch in this position. This is done when there is a known problem with the outdoor section, or when the green “Check” lamp comes on indicating a problem.

TRANSFORMER TAPS

230/208V, 1 phase and 3 phase equipment employ dual primary voltage transformers. All equipment leaves the factory wired on 240V tap. For 208V operation, reconnect from 240V to 208V tap. The acceptable operating voltage range for the 240 and 208V taps are:

TAP	RANGE
240	253 – 216
208	220 – 187

NOTE: The voltage should be measured at the field power connection point in the unit and while the unit is operating at full load (maximum amperage operating condition).

COMPRESSOR CUTOFF THERMOSTAT and OUTDOOR THERMOSTAT WIRING

Heat pump compressor operation at outdoor temperatures below 0°F are neither desirable nor advantageous in terms of efficiency. Since most equipment at time of manufacture is not designated for any specific destination of the country and most of the equipment is installed in areas not approaching the lower outdoor temperature range, the compressor cutoffs are not factory installed.

Outdoor thermostats are available to hold off various banks of electric heat until needed as determined by outdoor temperature. The set point of either type of thermostat is variable with geographic region and sizing of the heating equipment to the structure. Utilization of the Heating Application Data and the heat loss calculation of the building are useful in determining the correct set points. Refer to Installation Instructions of CMH-14 Outdoor Thermostat Kit for more information.

FIGURE 7
UNIT 24V TERMINAL BOARD (5 — 10 KW)

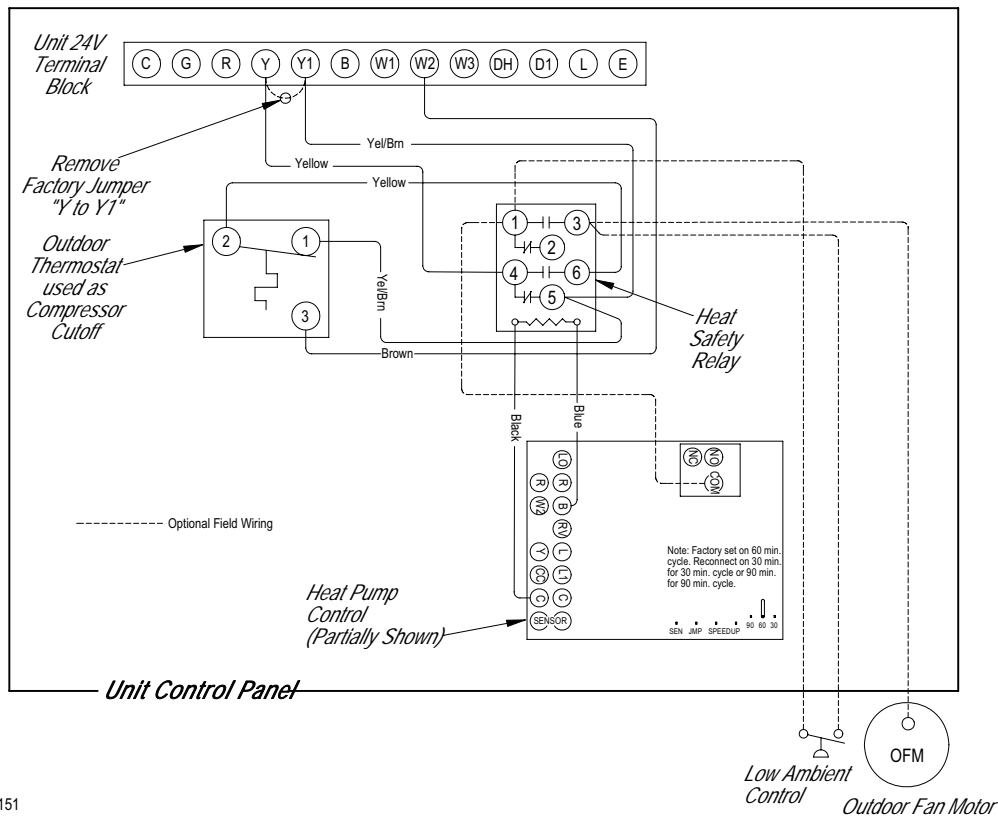

COMPRESSOR CUTOFF THERMOSTAT WIRING (5 — 10 KW) (FIGURE 7)

COMPRESSOR CUTOFF THERMOSTAT WIRING (15 — 20 KW) (FIGURE 8)

TABLE 8
5 — 10 KW

TABLE 9
15 — 20 KW

Model	KW	Volts	Phase
PH13241-A	0,5,10	230	1
PH13301-A	0,5,10	230	1
PH13361-A	0,5	230	1
PH13361-B	0,9	230	3
PH13421-A	0,5,10	230	1
PH13421-B	0,9	230	3
PH13481-A	0,5,10	230	1
PH13481-B	0,9	230	3
PH13601-A	0,5,10	230	1
PH13601-B	0,9	230	3

Model	KW	Volts	Phase
PH13301-A	15	230	1
PH13361-A	15	230	1
PH13361-B	15	230	3
PH13421-A	15	230	1
PH13421-B	15	230	3
PH13481-A	15	230	1
PH13481-B	15	230	3
PH13601-A	15	230	1
PH13601-B	15	230	3

FIGURE 8
UNIT 24V TERMINAL BOARD (15 THROUGH 20 KW)

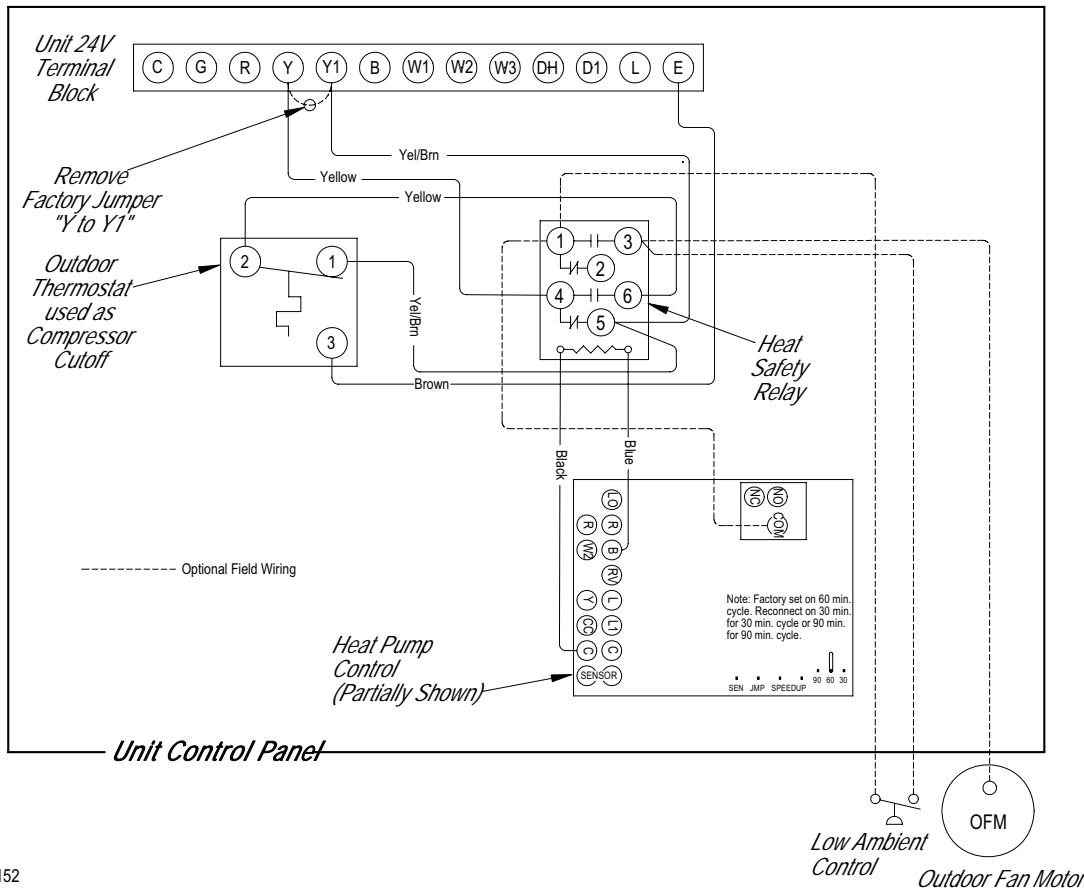

MIS-2152

START UP

These units require R-410A refrigerant and polyolester oil.

GENERAL:

1. Use separate service equipment to avoid cross contamination of oil and refrigerants.
2. Use recovery equipment rated for R-410A refrigerant.
3. Use manifold gauges rated for R-410A (800 psi/250 psi low).
4. R-410A is a binary blend of HFC-32 and HFC-125.
5. R-410A is nearly azeotropic - similar to R-22 and R-12. Although nearly azeotropic, charge with liquid refrigerant.
6. R-410A operates at 40-70% higher pressure than R-22, and systems designed for R-22 cannot withstand this higher pressure.
7. R-410A has an ozone depletion potential of zero, but must be reclaimed due to its global warming potential.
8. R-410A compressors use polyolester oil.
9. Polyolester oil is hygroscopic; it will rapidly absorb moisture and strongly hold this moisture in the oil.
10. A liquid line dryer must be used - even a deep vacuum will not separate moisture from the oil.
11. Limit atmospheric exposure to 15 minutes.
12. If compressor removal is necessary, always plug compressor immediately after removal. Purge with small amount of nitrogen when inserting plugs.

TOPPING OFF SYSTEM CHARGE

If a leak has occurred in the system, Bard Manufacturing recommends reclaiming, evacuating (see criteria above), and charging to the nameplate charge. Topping off the system charge can be done without problems.

With R-410A, there are no significant changes in the refrigerant composition during multiple leaks and recharges. R-410A refrigerant is close to being an azeotropic blend (it behaves like a pure compound or single component refrigerant). The remaining refrigerant charge, in the system, may be used after leaks have occurred and then “top-off” the charge by utilizing the charging charts on the inner control panel cover as a guideline.

REMEMBER: When adding R-410A refrigerant, it must come out of the charging cylinder/tank as a liquid to avoid any fractionation, and to insure optimal system performance. Refer to instructions for the cylinder that is being utilized for proper method of liquid extraction.

SAFETY PRACTICES:

1. Never mix R-410A with other refrigerants.
2. Use gloves and safety glasses, polyolester oils can be irritating to the skin, and liquid refrigerant will freeze the skin.
3. Never use air and R-410A to leak check; the mixture may become flammable.
4. Do not inhale R-410A – the vapor attacks the nervous system, creating dizziness, loss of coordination and slurred speech. Cardiac irregularities, unconsciousness and ultimate death can result from breathing this concentration.
5. Do not burn R-410A. This decomposition produces hazardous vapors. Evacuate the area if exposed.
6. Use only cylinders rated DOT4BA/4BW 400.
7. Never fill cylinders over 80% of total capacity.
8. Store cylinders in a cool area, out of direct sunlight.
9. Never heat cylinders above 125°F.
10. Never trap liquid R-410A in manifold sets, gauge lines or cylinders. R-410A expands significantly at warmer temperatures. Once a cylinder or line is full of liquid, any further rise in temperature will cause it to burst.

START UP NOTES

For improved start up performance, wash the indoor coil with dishwasher detergent.

START UP AND OPERATION

THREE PHASE SCROLL COMPRESSOR START UP INFORMATION

Scroll compressors, like several other types of compressors, will only compress in one rotational direction. Direction of rotation is not an issue with single phase compressors since they will always start and run in the proper direction.

However, three phase compressors will rotate in either direction depending upon phasing of the power. Since there is a 50-50 chance of connecting power in such a way as to cause rotation in the reverse direction, verification of proper rotation must be made. Verification of proper rotation direction is made by observing that suction pressure drops and discharge pressure rises when the compressor is energized. Reverse rotation also results in an elevated sound level over that with correct rotation, as well as, substantially reduced current draw compared to tabulated values.

Verification of proper rotation must be made at the time the equipment is put into service. If improper rotation is corrected at this time there will be no negative impact on the durability of the compressor. However, reverse operation for over one hour may have a negative impact on the bearing due to oil pump out.

NOTE: If compressor is allowed to run in reverse rotation for several minutes the compressor's internal protector will trip.

All three phase scroll compressors are wired identically internally. As a result, once the correct phasing is determined for a specific system or installation, connecting properly phased power leads to the same Fusite terminals should maintain proper rotation direction.

The direction of rotation of the motor may be changed by reversing any two line connections to the unit.

SEQUENCE OF OPERATION

BLOWER ONLY – When the “Fan” switch on the room thermostat is placed in the “On” position (circuit R-G makes), the blower will energize and run until the “Fan” switch is placed back into the “Auto” position. This will allow for constant air circulation at a lower airflow during times when the unit is not in operation for cooling or heating.

COOLING – On a call for cooling from the room thermostat (circuit R-Y makes), the blower will energize (circuit R-G is automatic when R-Y makes) as well as the compressor, and outdoor fan motor. Note that if the “Fan” switch on the room thermostat is in the “On” position and the blower is already in operation, then the motor will ramp up to the required speed for cooling.

HEATING (1st Stage) – On a call for heating from the room thermostat (circuit R-Y&B makes), the blower will energize (circuit R-G is automatic when R-Y makes) as well as the compressor, outdoor fan motor, and reversing valve solenoid coil. This will place the system into heat pump operation to maintain the thermostat set temperature. Note that if the “Fan” switch on the room thermostat is in the “On” position and the blower is already in operation, then the motor will ramp up to the required speed for heating.

HEATING (1st Stage Defrost) – During the defrost cycle, the heat pump control will energize electric heaters, if installed, (circuit R-W2 makes), allowing room temperature to be maintained during heat pump defrost operation.

HEATING (2nd Stage) – If the operation of the heat pump will not maintain the set room temperature, then the thermostat will call for additional heat from electric heaters to help maintain the set temperature. On a call for second stage heating from the room thermostat (circuit R-W2 makes), backup electric heaters will be energized if installed.

HEATING (Em Heat) – When the room thermostat is placed in the “Em Heat” position (circuit R-E makes), the blower and electric heaters, if installed, will energize on second stage heat (circuit R-W2&W3 makes), with the compressor and outdoor fan motor locked out of operation.

DEFROST CYCLE

The defrost cycle is controlled by temperature and time on the solid state heat pump control. See Figure 9.

When the outdoor temperature is in the lower 40°F temperature range or colder, the outdoor coil temperature is 32°F or below. This coil temperature is sensed by the defrost sensor mounted near the bottom of the outdoor coil. Once the Heat Pump Control board sees the resistance of the defrost sensor has been below the resistance of 34545 (30°F) for 60 minutes of accumulated run time. The Heat Pump Control Board will start the defrost cycle by de-energizing the reversing valve and condenser fan. It will also send a signal to W2 to energize the electric heat if equipped. When the Heat Pump Control Board reads the resistance of the defrost sensor has risen to 16547 (57°F) or it has been in defrost for 10 minutes the defrost cycle will terminate.

After 30 minutes at 30°F or below, the heat pump control will place the system in the defrost mode.

During the defrost mode, the refrigerant cycle switches back to the cooling cycle, the outdoor motor stops, electric heaters are energized, and hot gas passing through the outdoor coil melts any accumulated frost. When the temperature rises to approximately 57°F the coil sensor will send a signal to the heat pump control which will return the system to heating operations automatically.

If some abnormal or temporary condition such as a high wind causes the heat pump to have a prolonged defrost cycle, the heat pump control will restore the system to heating operation automatically after 10 minutes.

There are three settings on the heat pump control – 30 minute, 60 minute and 90 minute. Models are shipped wired on the 60 minute setting for greatest operating

economy. If special circumstances require a change to another time, remove wire connected to terminal 60 and reconnect to desired terminal. Refer to Figure 9. The manufacturer's recommendation is for 60 minute defrost cycles.

There is a cycle speed up jumper on the control. This can be used to reduce the time between defrost cycle operation without waiting for time to elapse.

Use a small screwdriver or other metallic object, or another 1/4 inch QC to short between the *SPEEDUP* terminals to accelerate the HPC timer and initiate defrost.

Be careful not to touch any other terminals with instrument used to short the *SPEEDUP* terminals. It may take up to 10 seconds with the *SPEEDUP* terminals shorted for the speedup to be completed and the defrost cycle to start.

As soon as the defrost cycle kicks in remove the shorting instrument from the *SPEEDUP* terminals.

Otherwise the timing will remain accelerated and run through the 1 minute maximum defrost length sequence in a matter of seconds and will automatically terminate the defrost sequence.

There is an initiate defrost jumper (sen jump) on the control that can be used at any outdoor ambient during the heating cycle to simulate a 0° coil temperature. This can be used to check defrost operation of the unit without waiting for the outdoor ambient to fall into the defrost region.

By placing a jumper across the *SEN JMP* terminals (a 1/4 inch QC terminal works best) the defrost sensor mounted on the outdoor coils is shunted out and will activate the timing circuit. This permits the defrost cycle to be checked out in warmer weather conditions without the outdoor temperature having to fall into the defrost region.

In order to terminate the defrost test in the *SEN JMP* jumper must be removed. If left in place too long the compressor could stop due to the high pressure control opening because of the high pressure condition created by operating in the cooling mode with outdoor fan off. Pressure will rise fairly fast as there is likely no actual frost on the outdoor coil in this artificial test condition.

There is also a 5 minute compressor time delay function built into the HPC, This is to protect the compressor from instances it is helpful to the service technician to override or speed up this timing period, and shorting out the speedup terminals for a few seconds can do this.

**FIGURE 9
HEAT PUMP CONTROL BOARD**

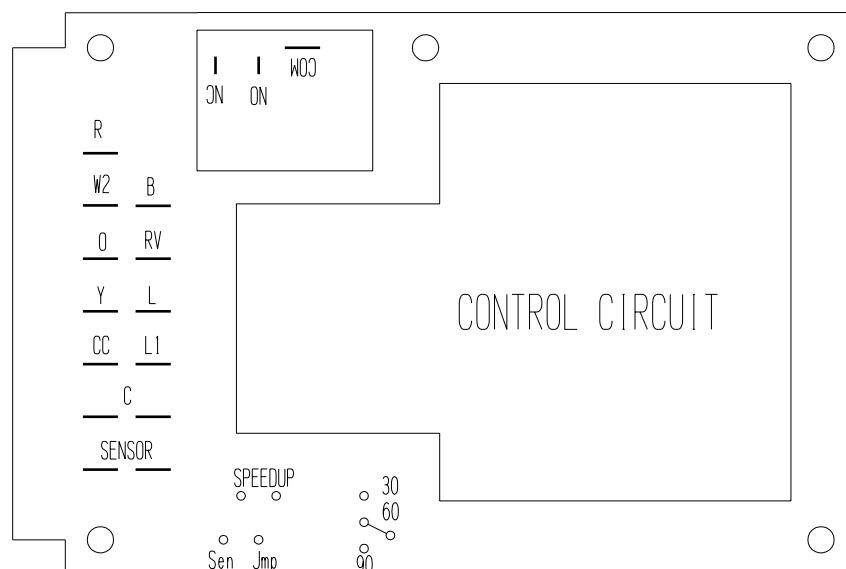

MIS-1191

TROUBLESHOOTING

SOLID STATE HEAT PUMP CONTROL TROUBLESHOOTING PROCEDURE

1. Turn on AC power supply to unit.
2. Turn thermostat blower switch to fan on. The indoor blower should start. (If it doesn't, troubleshoot indoor unit and correct problem.)
3. Turn thermostat blower switch to Auto position. Indoor blower should stop.

4. Set system switch to heat or cool. Adjust thermostat to call for heat or cool. The indoor blower, compressor, and outdoor fan should start.

NOTE: If there is no power to 24 volt transformer, the compressor and outdoor fan motor will not start for 5 minutes. This is because of the compressor short cycle protection.

TROUBLESHOOTING

Symptom	Possible Causes	What & How to Check / Repair
Compressor will not start (heating or cooling)	Check for 24V from R to C on the heat pump control	If 24V is not present at R, check wiring from board to transformer and check transformer input and output voltage. If transformer has no 24V output, determine cause and replace transformer.
	Check for 24V from Y to C on low voltage terminal strip	If 24V is not present, check thermostat and thermostat wiring, outdoor thermostat (if equipped) phase monitor (if equipped). If 24V is present continue to next step.
	Check for 24V from C to CC on heat pump control	If 24V is present, check and/or replace compressor contactor. If 24V is not present, jump the speed up terminal for 10 seconds. If compressor does not start check for 24V from C to L1 on the heat pump control.
	Compressor lock out	If 24V is not present at L1 of the heat pump control, check the high pressure switch and low pressure bypass relay (if equipped) and all associated wiring and terminals. The safety circuit is a closed circuit. If the high pressure switch or low pressure bypass relay are open, the control will lock out the compressor. Replace defective component. Cycle power off and on to reset lock out. Jump speed up terminals for 10 seconds to override 5-minute time delay.
	Defective heat pump control	If 24V is present from C to Y, and C to L1 on the heat pump control, the time delay has been overridden or expired and no 24V is present at CC, replace the heat pump control.
Fan outdoor motor does not run (cooling or heating except during defrost)	Motor defective	Check for open or shorted motor winding. Replace motor.
	Motor capacitor defective	Check capacitor rating. Check for open or shorted capacitor. Replace capacitor.
	Heat pump control defective	Check across fan relay on heat pump control. (Com-NC) Replace heat pump control.
Reversing valve does not energize (heating only)	Reversing valve solenoid coil defective	Check for open or shorted coil. Replace solenoid coil.
	Heat pump control defective	Check for 24V between RV-C and B-C. 1. Check control circuit wiring. 2. Replace heat pump control
Unit will not go into defrost (heating only)	Temperature sensor or heat pump control defective	Disconnect temperature sensor from board and jumper across speed up terminals and sen jump terminals. This should cause the unit to go through a defrost cycle within one minute. 1. If unit goes through defrost cycle, replace temperature sensor. 2. If unit does not go through defrost cycle, replace heat pump control.
Unit will not come out of defrost (heating only)	Temperature sensor or heat pump control defective.	Jumper across speed up terminal. This should cause the unit to come out of defrost within one minute. 1. If unit comes out of defrost cycle, replace temperature sensor. 2. If unit does not come out of defrost cycle, replace heat pump control.

CHECKING TEMPERATURE SENSOR CHECK OUT

1. Disconnect temperature sensor from board and from outdoor coil.
2. Use an ohmmeter and measure the resistance of the sensor. Also use ohmmeter to check for short or open.
3. Check resistance reading to chart of resistance; use sensor ambient temperature. (Tolerance of part is $\pm 10\%$.)
4. If sensor resistance reads very low, then sensor is shorted and will not allow proper operation of the heat pump control.
5. If sensor is out of tolerance, shorted, open, or reads very low ohms then it should be replaced.

TEMPERATURE F VS RESISTANCE R OF TEMPERATURE SENSOR

F	R	F	R	F	R	F	R
-25.0	196871	13.0	56985	53.0	19374	89.0	7507
-24.0	190099	14.0	55284	52.0	18867	90.0	7334
-23.0	183585	15.0	53640	53.0	18375	91.0	7165
-22.0	177318	16.0	52051	54.0	17989	92.0	7000
-21.0	171289	17.0	50514	55.0	17434	93.0	6840
-20.0	165487	18.0	49028	56.0	16984	94.0	6683
-19.0	159904	19.0	47590	57.0	16547	95.0	6531
-18.0	154529	20.0	46200	58.0	16122	96.0	6383
-17.0	149355	21.0	44855	59.0	15710	97.0	6239
-16.0	144374	22.0	43554	60.0	15310	98.0	6098
-15.0	139576	23.0	42295	61.0	14921	99.0	5961
-14.0	134956	24.0	41077	62.0	14544	100.0	5827
-13.0	130506	25.0	39898	63.0	14177	101.0	5697
-12.0	126219	26.0	38757	64.0	13820	102.0	5570
-11.0	122089	27.0	37652	65.0	13474	103.0	5446
-10.0	118108	28.0	36583	66.0	13137	104.0	5326
-9.0	114272	29.0	35548	67.0	12810	105.0	5208
-8.0	110575	30.0	34545	68.0	12492	106.0	5094
-7.0	107010	31.0	33574	69.0	12183	107.0	4982
-6.0	103574	32.0	32634	70.0	11883	108.0	4873
-5.0	100260	33.0	31723	71.0	11591	109.0	4767
-4.0	97064	34.0	30840	72.0	11307	110.0	4663
-3.0	93981	35.0	29986	73.0	11031	111.0	4562
-2.0	91008	36.0	29157	74.0	10762	112.0	4464
-1.0	88139	37.0	28355	75.0	10501	113.0	4367
0.0	85371	38.0	27577	76.0	10247	114.0	4274
1.0	82699	39.0	26823	77.0	10000	115.0	4182
2.0	80121	40.0	26092	78.0	9760	116.0	4093
3.0	77632	41.0	25383	79.0	9526	117.0	4006
4.0	75230	42.0	24696	80.0	9299	118.0	3921
5.0	72910	43.0	24030	81.0	9077	119.0	3838
6.0	70670	44.0	23384	82.0	8862	120.0	3757
7.0	68507	45.0	22758	83.0	8653	121.0	3678
8.0	66418	46.0	22150	84.0	8449	122.0	3601
9.0	64399	47.0	21561	85.0	8250	123.0	3526
10.0	62449	48.0	20989	86.0	8057	124.0	3452
11.0	60565	49.0	20435	87.0	7869		
12.0	58745	50.0	19896	88.0	7686		

SERVICE

SERVICE HINTS

1. Caution homeowner to maintain clean air filters at all times. Also, not to needlessly close off supply and return air registers. This reduces air flow through the system which shortens equipment service life as well as increasing operating costs.
2. Switching to heating cycle at 75°F or higher outside temperature may cause a nuisance trip of the high pressure switch.
3. The heat pump wall thermostats perform multiple functions. Be sure that all function switches are correctly set for the desired operating mode before trying to diagnose any reported service problems.
4. Check all power fuses or circuit breakers to be sure that they are the correct rating.
5. Periodic cleaning of the outdoor coil to permit full and unrestricted airflow circulation is essential.

PRESSURE SERVICE PORTS

High and low pressure service ports are installed on all units so that the system operating pressures can be observed. Pressure tables can be found in Tables 13 & 14 in this manual covering all models on both cooling and heating cycles. It is imperative to match the correct pressure table to the unit by model number.

REFRIGERANT CHARGE

The correct system R-410A charge is shown on the unit rating plate. Optimum unit performance will occur with a refrigerant charge resulting in a suction line temperature (6" from compressor) as shown in Table 10.

**TABLE 10
REFRIGERANT CHARGE**

Model	Rated Airflow	95° OD Temperature	82° OD Temperature
PH1324	800	99 - 100	87 - 88
PH1330	1000	96 - 97	83 - 84
PH1336	1100	96 - 97	84 - 85
PH1342	1400	100 - 101	88 - 89
PH1348	1550	99 - 100	87 - 88
PH1360	1650	100 - 101	88 - 89

The above liquid line temperatures are based upon 80°F dry bulb/67°F wet bulb (50% RH) temperature and rated airflow across the evaporator during cooling cycle.

FAN BLADE SETTINGS

Shown in Figure 10 are the correct fan blade setting dimensions for proper air delivery across the outdoor coil.

Any service work requiring removal or adjustment in the fan and/or motor area will require that the dimensions in Table 11 be checked and blade adjusted in or out on the motor shaft accordingly.

**FIGURE 10
FAN BLADE SETTING**

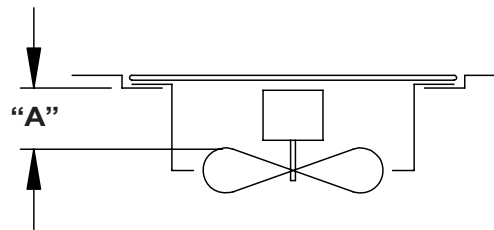

MD-1417BC

**TABLE 11
FAN BLADE SETTING
DIMENSIONS**

Model	Dimension "A"
PH1324	3.25"
PH1330	
PH1336	
PH1342	
PH1348	
PH1360	

SUCTION AND DISCHARGE TUBE BRAZING

Compliant Scroll compressors have copper plated steel suction and discharge tubes. These tubes are far more rugged and less prone to leaks than copper tubes used on other compressors. Due to different thermal properties of steel and copper, brazing procedures may have to be changed from those commonly used.

- To disconnect: heat joint Areas 2 and 3 slowly and uniformly until braze material softens and the tube can be pulled out of suction fitting. (See Figure 11.)
- To connect:
 - Recommended brazing materials: silfos with minimum 5% silver or silver braze material with flux.

- Reinsert tube into fitting.
- Heat tube uniformly in Area 1 moving slowly to Area 2. When joint reaches brazing temperature, apply brazing material. (See Figure 11.)
- Heat joint uniformly around the circumference to flow braze material completely around the joint.
- Slowly move torch into Area 3 to draw braze material into joint. (See Figure 11.)
- **Do not** overheat joint.

**FIGURE 11
BRAZING DIAGRAM**

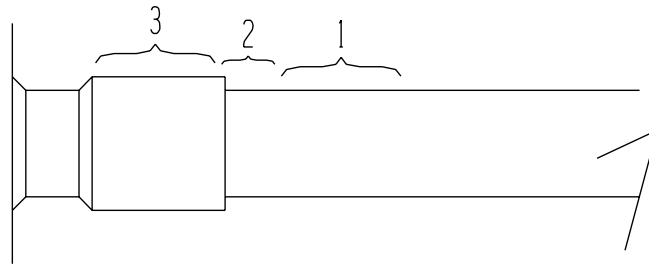

MIS-1179

**TABLE 12
INDOOR BLOWER PERFORMANCE ①**

Model	Rated ESP	MAX ESP	② Continuous Airflow	③ Rated Cooling CFM	④ Rated Heating CFM
PH1324	0.10	0.50	600	800	800
PH1330	0.15	0.50	750	1000	1000
PH1336	0.15	0.50	825	1100	1100
PH1342	0.20	0.50	925	1400	1400
PH1348	0.20	0.50	1025	1550	1550
PH1360	0.20	0.50	1150	1650	1650

① Motor will deliver consistent CFM through voltage supply range with no deterioration (197-253V for all 230/208V models).

② Continuous CFM is the total air being circulated during continuous (manual fan) mode.

③ Will occur automatically with a call for "Y" for cooling mode operation.

④ Will occur automatically with a call for "W1" for heating mode operation.

TROUBLESHOOTING GE ECM™ MOTORS

CAUTION:

Disconnect power from unit before removing or replacing connectors, or servicing motor. To avoid electric shock from the motor's capacitors, disconnect power and wait at least 5 minutes before opening motor.

Symptom

Motor rocks slightly when starting

Motor won't start

• No movement

• Motor rocks, but won't start

Motor oscillates up & down while being tested off of blower

Motor starts, but runs erratically

• Varies up and down or intermittent

• "Hunts" or "puffs" at high CFM (speed)

• Stays at low CFM despite system call for cool or heat CFM

• Stays at high CFM

• Blower won't shut off

Excessive noise

• Air noise

Cause/Procedure

• This is normal start-up for ECM

- Check blower turns by hand
- Check power at motor
- Check low voltage (24 Vac R to C) at motor
- Check low voltage connections (G, Y, W, R, C) at motor
- Check for unseated pins in connectors on motor harness
- Test with a temporary jumper between R - G
- Check motor for tight shaft
- Perform motor/control replacement check
- **Perform Moisture Check**

- Check for loose or compliant motor mount
- Make sure blower wheel is tight on shaft
- Perform motor/control replacement check

• It is normal for motor to oscillate with no load on shaft

- Check line voltage for variation or "sag"
- Check low voltage connections (G, Y, W, R, C) at motor, unseated pins in motor harness connectors
- Check "BK" for erratic CFM command (in variable-speed applications)
- Check out system controls, Thermostat
- **Perform Moisture Check**

- Does removing panel or filter reduce "puffing"?
- Reduce restriction
- Reduce max airflow

- Check low voltage (Thermostat) wires and connections
- Verify fan is not in delay mode; wait until delay complete
- "R" missing/not connected at motor
- Perform motor/control replacement check

- "R" missing/not connected at motor
- Is fan in delay mode? - wait until delay time complete
- Perform motor/control replacement check

• Current leakage from controls into G, Y or W? Check for Triac switched thermostat or solid-state relay

- Determine if it's air noise, cabinet, duct or motor noise; interview customer, if necessary
- High static creating high blower speed?
- Is airflow set properly?
- Does removing filter cause blower to slow down? Check filter
- Use low-pressure drop filter
- Check/correct duct restrictions

Symptom

• Noisy blower or cabinet

• "Hunts" or "puffs" at high CFM (speed)

Evidence of Moisture

- Motor failure or malfunction has occurred and moisture is present
- Evidence of moisture present inside air mover

Do

- Check out motor, controls, wiring and connections thoroughly before replacing motor
- Orient connectors down so water can't get in
 - Install "drip loops"
- Use authorized motor and model #'s for replacement
- Keep static pressure to a minimum:
 - Recommend high efficiency, low static filters
 - Recommend keeping filters clean.
 - Design ductwork for min. static, max. comfort
 - Look for and recommend ductwork improvement, where necessary

- Size the equipment wisely
- Check orientation before inserting motor connectors

Moisture Check

- Connectors are oriented "down" (or as recommended by equipment manufacturer)
- Arrange harness with "drip loop" under motor
- Is condensate drain plugged?
- Check for low airflow (too much latent capacity)
- Check for undercharged condition
- Check and plug leaks in return ducts, cabinet

Comfort Check

- Check proper airflow settings
- Low static pressure for lowest noise
- Set low continuous-fan CFM
- Use humidistat and 2-speed cooling units
- Use zoning controls designed for ECM that regulate CFM
- Thermostat in bad location?

Cause/Procedure

- Check for loose blower housing, panels, etc.
- High static creating high blower speed?
 - Check for air whistling through seams in ducts, cabinets or panels
 - Check for cabinet/duct deformation

- Does removing panel or filter reduce "puffing"?
- Reduce restriction
- Reduce max. airflow

• Replace motor and **Perform Moisture Check**

• **Perform Moisture Check**

Don't

- Automatically assume the motor is bad.
- Locate connectors above 7 and 4 o'clock positions
- Replace one motor or control model # with another (unless an authorized replacement)
- Use high pressure drop filters some have ½" H₂O drop!
- Use restricted returns
- Oversize system, then compensate with low airflow
- Plug in power connector backwards
- Force plugs

TROUBLESHOOTING GE ECM™ MOTORS Cont'd.

Replacing ECM Control Module

To replace the control module for the GE variable-speed indoor blower motor you need to take the following steps:

1. You **MUST** have the correct replacement module. The controls are factory programmed for specific operating modes. Even though they look alike, different modules may have completely different functionality.

USING THE WRONG CONTROL MODULE VOIDS ALL PRODUCT WARRANTIES AND MAY PRODUCE UNEXPECTED RESULTS.

2. Begin by removing AC power from the furnace or air handler being serviced. **DO NOT WORK ON THE MOTOR WITH AC POWER APPLIED.** To avoid electric shock from the motor's capacitors, disconnect power and wait at least 5 minutes before opening motor.

3. It is usually not necessary to remove the motor from the blower assembly. However, it is recommended that the whole blower assembly, with the motor, be removed from the furnace/air handler. (Follow the manufacturer's procedures). Unplug the two cable connectors to the motor. There are latches on each connector. **DO NOT PULL ON THE WIRES.** The plugs remove easily when properly released.

4. Locate the two standard 1/4" hex head bolts at the rear of the control housing (at the back end of the control opposite the shaft end). Refer to Figure 12. Remove these two bolts from the motor and control assembly while holding the motor in a way that will prevent the motor or control from falling when the bolts are removed. If an ECM2.0 control is being replaced (recognized by an aluminum casting rather than a deep-drawn black steel can housing the electronics), remove only the hex-head bolts. **DO NOT REMOVE THE TORX-HEAD SCREWS.**

5. The control module is now free of mechanical attachment to the motor endshield but is still connected by a plug and three wires inside the control. Carefully rotate the control to gain access to the plug at the control end of the wires. With thumb and forefinger, reach the latch holding the plug to the control and release it by squeezing the latch tab and the opposite side of the connector plug and gently pulling the plug out of the connector socket in the control. **DO NOT PULL ON THE WIRES. GRIP THE PLUG ONLY.**

6. The control module is now completely detached from the motor. Verify with a standard ohmmeter that the resistance from each motor lead (in the motor plug just removed) to the motor shell is >100K ohms. Refer to Figure 13. (Measure to unpainted motor end plate.) If any motor lead fails this test, do not proceed to install the control module. **THE MOTOR IS DEFECTIVE AND MUST BE REPLACED.** Installing the new control module will cause it to fail also.

7. Verify that the replacement control is correct for your application. Refer to the manufacturer's authorized replacement list. **USING THE WRONG CONTROL WILL RESULT IN IMPROPER OR NO BLOWER OPERATION.** Orient the control module so that the 3-wire motor plug can be inserted into the socket in the control. Carefully insert the plug and press it into the socket until it latches. **A SLIGHT CLICK WILL BE HEARD WHEN PROPERLY INSERTED.** Finish installing the replacement control per one of the three following paragraphs, 8a, 8b or 8c.

8a. **IF REPLACING AN ECM 2.0 CONTROL** (control in cast aluminum can with air vents on the back of the can) **WITH AN ECM 2.3 CONTROL** (control containing black potting for water protection in black deep-drawn steel case with no vents in the bottom of the can), locate the two through-bolts and plastic tab that are packed with the replacement control. Insert the plastic tab into the slot at the perimeter of the open end of the can so that the pin is located on the inside of the perimeter of the can. Rotate the can so that the tab inserts into the tab locator hole in the endshield of the motor. Using the two through-bolts provided with the replacement control, reattach the can to the motor.

THE TWO THROUGH-BOLTS PROVIDED WITH THE REPLACEMENT ECM 2.3 CONTROL ARE SHORTER THAN THE BOLTS ORIGINALLY REMOVED FROM THE ECM 2.0 CONTROL AND MUST BE USED IF SECURE ATTACHMENT OF THE CONTROL TO THE MOTOR IS TO BE ACHIEVED. DO NOT OVERTIGHTEN THE BOLTS.

8b. **IF REPLACING AN ECM 2.3 CONTROL WITH AN ECM 2.3 CONTROL**, the plastic tab and shorter through-bolts are not needed. The control can be oriented in two positions 180° apart. **MAKE SURE THE ORIENTATION YOU SELECT FOR REPLACING THE CONTROL ASSURES THE CONTROL'S CABLE CONNECTORS WILL BE LOCATED DOWNWARD IN THE APPLICATION SO THAT WATER CANNOT RUN DOWN THE CABLES AND INTO THE CONTROL.** Simply orient the new control to the motor's endshield, insert bolts, and tighten. **DO NOT OVERTIGHTEN THE BOLTS.**

8c. **IF REPLACING AN ECM 2.0 CONTROL WITH AN ECM 2.0 CONTROL** (It is recommended that ECM 2.3 controls be used for all replacements), the new control must be attached to the motor using through-bolts identical to those removed with the original control. **DO NOT OVERTIGHTEN THE BOLTS.**

9. Reinstall the blower/motor assembly into the HVAC equipment. Follow the manufacturer's suggested procedures.

10. Plug the 16-pin control plug into the motor. The plug is keyed. Make sure the connector is properly seated and latched.

11. Plug the 5-pin power connector into the motor. Even though the plug is keyed, **OBSERVE THE PROPER ORIENTATION. DO NOT FORCE THE CONNECTOR.** It plugs in very easily when properly oriented. **REVERSING THIS PLUG WILL CAUSE IMMEDIATE FAILURE OF THE CONTROL MODULE.**

12. Final installation check. Make sure the motor is installed as follows:

- Unit is as far INTO the blower housing as possible.
- Belly bands are not on the control module or covering vent holes.
- Motor connectors should be oriented between the 4 o'clock and 8 o'clock positions when the blower is positioned in its final location and orientation.
- Add a drip loop to the cables so that water cannot enter the motor by draining down the cables. Refer to Figure 14.

The installation is now complete. Reapply the AC power to the HVAC equipment and verify that the new motor control module is working properly. Follow the manufacturer's procedures for disposition of the old control module.

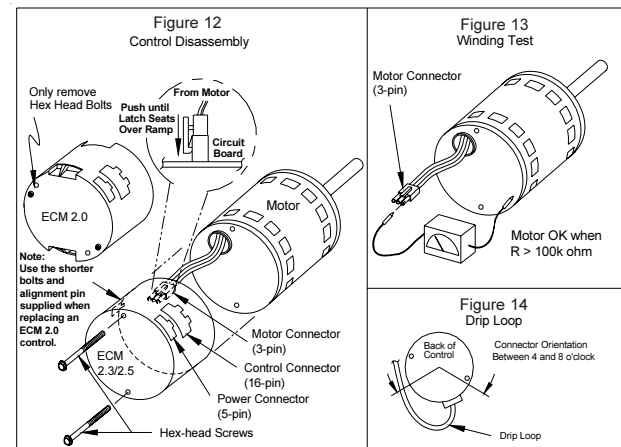

**TABLE 13
PRESSURE TABLE**

Air Temperature Entering Outdoor Coil Degree F

COOLING

Model	Return Air Temperature	Pressure	70°	75°	80°	85°	90°	95°	100°	105°	110°	115°	120°	125°
PH1324	75° DB	Low Side	123	126	128	130	132	134	136	137	138	139	140	141
	62° WB	High Side	281	299	319	341	363	388	413	442	471	501	534	567
PH1324	80° DB	Low Side	132	135	137	139	141	143	145	146	148	149	150	151
	67° WB	High Side	288	307	327	350	372	398	424	453	483	514	548	582
PH1324	85° DB	Low Side	142	145	147	149	152	154	156	157	159	160	161	162
	72° WB	High Side	298	318	338	362	385	412	439	469	500	532	567	602
PH1330	75° DB	Low Side	126	129	131	133	135	137	138	139	140	141	142	143
	62° WB	High Side	275	295	316	338	362	386	410	436	462	500	519	547
PH1330	80° DB	Low Side	135	138	140	142	144	146	148	149	150	151	152	153
	67° WB	High Side	282	303	324	347	371	396	421	447	474	513	532	561
PH1336	85° DB	Low Side	145	148	151	153	155	157	159	160	161	162	163	164
	72° WB	High Side	292	314	335	359	384	410	436	463	491	531	551	581
PH1336	75° DB	Low Side	121	122	125	127	129	131	132	133	134	135	136	137
	62° WB	High Side	277	304	332	357	383	410	435	460	486	511	536	561
PH1336	80° DB	Low Side	129	131	134	136	138	140	141	142	143	144	145	146
	67° WB	High Side	284	312	340	366	393	420	446	472	498	524	550	575
PH1336	85° DB	Low Side	139	141	144	146	148	151	152	153	154	155	156	157
	72° WB	High Side	294	323	352	379	407	435	462	489	515	542	569	595

HEATING

Air Temperature Entering Outdoor Coil Degree F

Model	Return Air Temperature	Pressure	0°	5°	10°	15°	20°	25°	30°	35°	40°	45°	50°	55°	60°
PH1324	70° DB	Low Side	27	35	43	51	59	66	74	81	88	95	102	109	115
		High Side	242	253	264	274	283	291	299	306	311	317	321	325	327
PH1330	70° DB	Low Side	40	46	51	57	64	71	78	85	92	100	109	118	126
		High Side	286	299	311	323	334	344	354	363	371	378	388	390	395
PH1336	70° DB	Low Side	32	39	46	53	60	67	75	82	89	97	104	112	120
		High Side	296	313	329	344	358	371	383	394	403	412	420	427	433

LOW SIDE PRESSURE ±2 PSIG
HIGH SIDE PRESSURE ±5 PSIG

**TABLE 14
PRESSURE TABLE**

Air Temperature Entering Outdoor Coil Degree F

COOLING

Model	Return Air Temperature	Pressure	65°	70°	75°	80°	85°	90°	95°	100°	105°	110°	115°	120°	125°
PH1342	75° DB	Low Side	125	127	128	130	132	133	135	135	136	137	138	138	139
	62° WB	High Side	232	256	281	305	330	354	378	408	437	466	495	525	554
PH1348	80° DB	Low Side	134	136	137	139	141	142	144	145	146	146	147	148	149
	67° WB	High Side	238	263	288	313	338	363	388	418	448	478	508	538	568
PH1360	85° DB	Low Side	144	146	148	149	151	153	155	156	157	157	158	159	160
	72° WB	High Side	246	272	298	324	350	376	402	433	464	495	526	557	588
PH1348	75° DB	Low Side	127	128	130	131	132	133	135	135	136	137	138	138	139
	62° WB	High Side	236	262	289	315	341	368	394	424	454	484	514	544	574
PH1348	80° DB	Low Side	136	137	139	140	141	143	144	145	146	146	147	148	149
	67° WB	High Side	242	269	296	323	350	377	404	435	466	496	527	558	589
PH1360	85° DB	Low Side	146	148	149	151	152	153	155	156	157	157	158	159	160
	72° WB	High Side	250	278	306	334	362	390	418	450	482	514	546	578	609
PH1360	75° DB	Low Side	122	122	123	124	125	126	127	128	129	131	132	133	
	62° WB	High Side	252	277	303	329	354	380	406	436	466	496	526	556	
PH1360	80° DB	Low Side	130	131	132	133	134	135	136	137	138	140	141	142	
	67° WB	High Side	258	284	311	337	363	390	416	447	478	508	539	570	
PH1360	85° DB	Low Side	140	141	142	143	144	145	146	147	149	150	151	153	
	72° WB	High Side	267	294	322	349	376	403	431	462	494	526	558	590	

HEATING

Air Temperature Entering Outdoor Coil Degree F

Model	Return Air Temperature	Pressure	0°	5°	10°	15°	20°	25°	30°	35°	40°	45°	50°	55°	60°
PH13421	70° DB	Low Side	34	41	48	55	62	69	77	84	91	98	105	112	120
		High Side	281	290	299	308	317	326	336	345	354	363	372	381	391
PH13481	70° DB	Low Side	33	40	47	54	61	68	75	82	89	96	103	110	117
		High Side	289	299	310	321	332	343	354	364	375	386	397	408	419
PH13601	70° DB	Low Side	32	38	45	52	59	66	73	79	86	93	100	107	114
		High Side	265	273	282	290	298	307	315	323	332	340	348	357	365

LOW SIDE PRESSURE ± 2 PSIG
HIGH SIDE PRESSURE ± 5 PSIG