

INSTALLATION INSTRUCTIONS

SINGLE PACKAGE HEAT PUMPS

MODELS

PH13242-A	PH13302-A
PH13363-A	PH13363-B
PH13422-A	PH13422-B
PH13422-C	PH13482-A
PH13482-B	PH13482-C
PH13602-A	PH13602-B
PH13602-C	

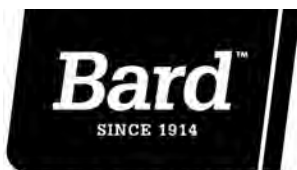

Climate Control Solutions

Bard Manufacturing Company, Inc.
Bryan, Ohio 43506

Since 1914 . . . Moving ahead, just as planned.

Manual : 2100-468J
Supersedes: 2100-468I
File: Volume II Tab 11
Date: 07-25-12

CONTENTS

Getting Other Informations and Publications..... 3

General Instructions

Important	4
Shipping Damage	4
General	4
Field-Installed Heater Packages (Optional)	4

Installation

Location	10
Slab Mounting	10
Winter Installation	10
Typical Installations	10 & 13
Condensate Drain Trap	13
Air Filters	13
Thermostats	14
Wiring – Main Power	15
Wiring – 24V Low Voltage Control Circuit	15
Thermostat Indicator Lamps	16
Emergency Heat Position	16
Transformer Taps	16
Compressor Cutoff Thermostat and Outdoor	16

Figures

Figure 1A Unit Dimensional Drawing	8
Figure 1B Unit Dimensional Drawing	9
Figure 2 Slab Mounting at Ground Level	11
Figure 3 Airflow and Service Access Clearances	11
Figure 4 Elevated Mounting Platform	12
Figure 5 Condensate Drain Trap	13
Figure 6 Low Voltage Wiring	15
Figure 7 Unit 24V Terminal Board (5–10 KW)	16
Figure 8 Unit 24V Terminal Board (15–20 KW)	17
Figure 9 Defrost Control Board	20
Figure 10 Fan Blade Setting	24
Figure 11 Brazing Diagram	27
Figure 12 Motor Connections	28
Figure 13 Wiring (Connections/Voltage)	29

Start Up and Operation

General	18
Topping Off System Charge	18
Safety Practices	18
Start Up Notes	18
Three Phase Scroll Compressor Start Up Information	19
Sequence of Operation	19
Defrost Cycle	20 & 21

Troubleshooting

Solid State Heat Pump Control Troubleshooting Procedure	22
Troubleshooting Guide	22
Checking Temperature Sensor Check Out	23
Temperature vs. Resistance of Temperature Sensor Chart	23

Service

Service Hints	24
Pressure Service Ports	24
R-410A Refrigerant Charge	24
Fan Blade Settings	24
Suction and Discharge Tube Brazing	27

Pressure Tables	24 & 25
-----------------------	---------

Troubleshooting GE ECM Blower Motors...28 & 29

Tables

Table 1 Rated CFM and ESP	4
Table 2 Electrical Data	5
Table 3 Optional Field Installed Heater Packages	6
Table 4 Opt. Field Installed Elec. Heater	7
Table 5 Required Filters	13
Table 6 Heat Pump Thermostats	14
Table 7 Thermostat Wire Size	14
Table 8 Compressor Cutoff Thermostat Wiring (5 - 10 KW)	17
Table 9 Compressor Cutoff Thermostat Wiring (15 - 20 KW)	17
Table 10 Troubleshooting	22
Table 11 Pressure Table - Cooling & Heating	25
Table 12 Pressure Table - Cooling & Heating	26
Table 13 Indoor Blower Performance	27

Getting Other Information and Publications

These publications can help you install the air conditioner or heat pump. You can usually find these at your local library or purchase them directly from the publisher. Be sure to consult current edition of each standard.

National Electrical CodeANSI/NFPA 70

Standard for the Installation.....ANSI/NFPA 90A
of Air Conditioning and Ventilating Systems

Standard for Warm AirANSI/NFPA 90B
Heating and Air Conditioning Systems

Load Calculation forACCA Manual J
Residential Winter and Summer Air Conditioning

Duct Design for Residential.....ACCA Manual D
Winter and Summer Air Conditioning and Equipment
Selection

FOR MORE INFORMATION, CONTACT THESE PUBLISHERS:

ACCA **Air Conditioning Contractors of America**
1712 New Hampshire Ave. N.W.
Washington, DC 20009
Telephone: (202) 483-9370
Fax: (202) 234-4721

ANSI **American National Standards Institute**
11 West Street, 13th Floor
New York, NY 10036
Telephone: (212) 642-4900
Fax: (212) 302-1286

ASHRAE **American Society of Heating Refrigerating,
and Air Conditioning Engineers, Inc.**
1791 Tullie Circle, N.E.
Atlanta, GA 30329-2305
Telephone: (404) 636-8400
Fax: (404) 321-5478

NFPA **National Fire Protection Association**
Batterymarch Park
P.O. Box 9101
Quincy, MA 02269-9901
Telephone: (800) 344-3555
Fax: (617) 984-7057

GENERAL INSTRUCTIONS

IMPORTANT

The equipment covered in this manual is to be installed by trained, experienced service and installation technicians. Any heat pump is more critical of proper operating charge and an adequate duct system than a straight air conditioning unit. All duct work, supply and return ducts, must be properly sized for the design airflow requirement of the equipment. ACCA is an excellent guide to proper sizing. All duct work or portions thereof not in the conditioned space should be properly insulated in order to both conserve energy and prevent condensation or moisture damage.

SHIPPING DAMAGE

Upon receipt of equipment, the carton should be checked for external signs of shipping damage. If damage is found, the receiving party must contact the last carrier immediately, preferably in writing, requesting inspection by the carrier's agent.

GENERAL

The refrigerant system is completely assembled and charged. All internal wiring is complete.

The unit is designed for use with or without duct work. Flanges are provided for attaching the supply and return ducts.

These instructions explain the recommended method to install the air cooled self-contained unit and the electrical wiring connections to the unit.

These instructions and any instructions packaged with any separate equipment required to make up the entire heat pump system should be carefully read before beginning the installation. Note particularly "Starting Procedure" and any tags and/or labels attached to the equipment.

While these instructions are intended as a general recommended guide, they do not supersede any national and/or local codes in any way. Authorities having jurisdiction should be consulted before the installation is made.

FIELD INSTALLED HEATER PACKAGES (OPTIONAL)

These packaged heat pumps are manufactured without supplementary electric heaters. Supplementary heaters are available for simple, fast field installation.

A separate power circuit is required for the supplementary heaters.

IMPORTANT: Refer to Table 1 when designing duct work for maximum available static pressure with heater installed.

Refer to Tables 2 and 4 for proper application information on all available heater combinations and what units they can be used with. It also shows the applicable circuit ampacities, fuse size, and wire size for each heater combination.

**TABLE 1
RATED CFM AND EXTERNAL STATIC PRESSURE (ESP)**

Model No.	Rated CFM	Recommended Airflow Range	Rated ESP	Max. ESP
PH1324	800	Note	0.10	0.50
PH1330	1000	Note	0.15	0.50
PH1336	1100	Note	0.15	0.50
PH1342	1450	Note	0.15	0.50
PH1348	1550	Note	0.20	0.50
PH1360	1750	Note	0.20	0.50

NOTE: Motor will adjust to deliver rated airflow.

**TABLE 2
ELECTRICAL DATA**

Model	PH13242-A	PH13302-A	PH13363-A	PH13363-B	PH13422-A	PH13422-B	PH13422-C	PH13482-A	PH13482-B	PH13482-C	PH13602-A	PH13602-B	PH13602-C
Electric Rating – 60 Hz – Circuit A	230/208-60-1	230/208-60-1	230/208-60-1	230/208-60-3	230/208-60-1	230/208-60-3	460-60-3	230/208-60-1	230/208-60-3	460-60-3	230/208-60-1	230/208-60-3	460-60-3
Operating Voltage Range	197 - 253	197 - 253	197 - 253	187 - 253	197 - 253	187 - 253	414-506	197 - 253	187 - 253	414-506	197 - 253	187 - 253	414-506
Minimum Circuit Ampacity	20	22	27	18	33	25	12	36	29	14	39	26	17
BCSC	13	14	17.5	11	21	15	8	22	14	8	26	16	9
Field Wire Size *	12	10	10	12	10	10	14	8	10	12	8	10	10
Ground Wire Size	12	10	8	12	10	10	14	8	10	14	8	10	12
Delay Fuse – Max. **	30	30	40	25	50	35	15	50	40	20	60	40	25
Total unit Amps – 230/208	11.2/12.2	14.8/16.3	19.4/21.9	13.9/15.4	21.9/22.9	17.1/17.9	10.4	24.7/26.6	18.0/19.2	10.7	25.3/28.9	17.7/19.9	11.9
Compressor – Circuit A													
Compressor Type	Scroll	Scroll	Scroll	Scroll	Scroll	Scroll	Scroll	Scroll	Scroll	Scroll	Scroll	Scroll	Scroll
Volts	230/208	230/208	230/208	230/208	230/208	230/208	460	230/208	230/208	460	230/208	230/208	460
Rated Load Amps	8/9	11/12.5	15/17.5	9.5/11	16.1/17.1	11.3/12.0	7.7	18.7/20.6	12.0/13.2	7.7	19.3/22.9	11.7/13.9	8.6
Lock Rotor Amps	58.3/58.3	73/73	79/79	88/88	115/115	115/115	50	117/117	83.1/83.1	50	134/134	110/110	52
Fan Motor and Condenser													
Fan Motor – HP/RPM	1/6 / 825	1/6 / 825	1/6 / 825	1/6 / 825	1/4 / 825	1/4 / 825	1/4 / 825	1/4 / 825	1/4 / 825	1/4 / 825	1/4 / 825	1/4 / 825	1/4 / 825
Fan Motor Amps	1.1	1.1	1.1	1.1	1.5	1.5	1.5	1.5	1.5	1.5	1.5	1.5	1.5
Fan – Dia./CFM	24"/2800	24"/2600	24"/2600	24"/2600	24"/3400	24"/3400	24"/3400	24"/3400	24"/3400	24"/3400	24"/3400	24"/3400	24"/3400
Motor and Evaporator													
Blower Motor – HP/RPM	1/3 ECM	1/2 ECM	1/2 ECM	1/2 ECM	1/2 ECM	1/2 ECM	1/2 ECM	3/4 ECM	3/4 ECM	3/4 ECM	3/4 ECM	3/4 ECM	3/4 ECM
Blower Motor – Amps	2.1	2.7	3.3	3.3	3.9	3.9	3.9	4.5	4.5	4.5	5.0	5.0	5.0
CFM Cooling	800	1000	1000	1000	1450	1450	1450	1550	1550	1550	1750	1750	1750
Charge (R-410A oz.)	75	136	136	136	170	170	160	180	180	160	190	190	160
Shipping Weight (pounds)	360	410	410	410	440	440	490	440	440	500	450	450	500

* 75 degree C copper wire

** Maximum time delay fuse of HACR type circuit breaker

**TABLE 3
OPTIONAL FIELD INSTALLED HEATER PACKAGES
ONLY TO BE USED WITH THE HEAT PUMP MODELS INDICATED**

Heater Package Model	Volts & Phase	PH13242-A	PH13302-A	PH13363-A	PH13363-B	PH13422-A	PH13422-B	PH13422-C	PH13482-A	PH13482-B	PH13482-C	PH13602-A	PH13602-B	PH13602-C
EHP323-A05	240/208-1	X	X	X										
EHP323-A10	240/208-1	X	X	X										
EHP323-A15	240/208-1		X ①	X ①										
EHP323-B09	240/208-3				X									
EHP323-B15	240/208-3				X ②									
EHP513-A05	240/208-1					X			X			X		
EHP513-A10	240/208-1					X			X			X		
EHP513-A15	240/208-1					X ①			X ①			X ①		
EHP513-B09	240/208-3									X			X	
EHP513-B15	240/208-3									X ②			X ②	
EHP513-C09	460-3							X			X			X
EHP513-C15	460-3							X ②			X ②			X ②

① Max. KW that can operate with Heat Pump on is 10 KW. 15 KW will operate during emergency heat.

② Max. KW that can operate with Heat Pump on is 9 KW. 15 KW will operate during emergency heat.

**TABLE 4
OPTIONAL FIELD INSTALLED ELECTRIC HEATER TABLE**

Heater Package Model No.	Unit Volts Phases	Htr. KW & Capacity @ 240 Volts		Htr. KW & Capacity @ 208 Volts		240/208V Htr. Amps	Heater Internal Fuse	Circuit B				
		KW	BTUH	KW	BTUH			No. Field Circuits	③ Min. Circuit Ampacity	① Max. Over Current Protection	② Field Power Wiring	② Ground Wire Size
EHP323-A05	240/208-1	5	17,100	3.75	12,800	20.8/18.1		1	26/23	30/25	10/10	10
EHP323-A10	240/208-1	10	34,100	7.50	26,000	41.6/36.2	30/60	1	53/46	60/50	6/8	10
EHP323-A15	240/208-1	15	51,200	11.25	38,400	62.5/54.1		1	79/68	80/70	4/4	8
EHP513-A05	240/208-1	5	17,100	3.75	12,800	20.8/18.1		1	26/23	30/25	10/10	10
EHP513-A10	240/208-1	10	34,100	7.50	26,000	41.6/36.2	30/60	1	53/46	60/50	6/8	10
EHP513-A15	240/208-1	15	51,200	11.25	38,400	62.5/54.1		1	79/68	80/70	4/4	8
EHP323-B09	240/208-3	9	30,700	6.75	23,000	21.7/18.7	None	1	28/24	30/25	10/10	10
EHP323-B15	240/208-3	15	51,200	11.25	38,400	36.2/31.2		1	46/39	50/40	8/8	10
EHP513-B09	240/208-3	9	30,700	6.75	23,000	21.7/18.7	None	1	28/24	30/25	10/10	10
EHP513-B15	240/208-3	15	51,200	11.25	38,400	36.2/31.2		1	46/39	50/40	8/8	10
EHP513-C09	480-3	9	30,700			10.8	None	1	14	15	14	14
EHP513-C15	480-3	15	51,200			18		1	28	30	10	12

- ① Time delay fuses of HACR type circuit breakers must be used for 60 and smaller sizes. Standard fuses or circuit breakers are suitable for sizes 70 and larger. 480V circuit breakers are not HACR type.
- ② Based on wire suitable for 75 degree C. Other wiring materials must be rated for marked Minimum Circuit Ampacity or greater.
- ③ Based upon Table 250-95 of N.E.C. 1993. See electric data for basic heat pump for Circuit A wiring specification requirements.

NOTE: While this electrical data is presented as a guide, it is important to electrically connect properly sized fuses and conductor wires in accordance with the national Electrical Code and all existing local codes.

**FIGURE 1A
UNIT DIMENSIONAL DRAWING**

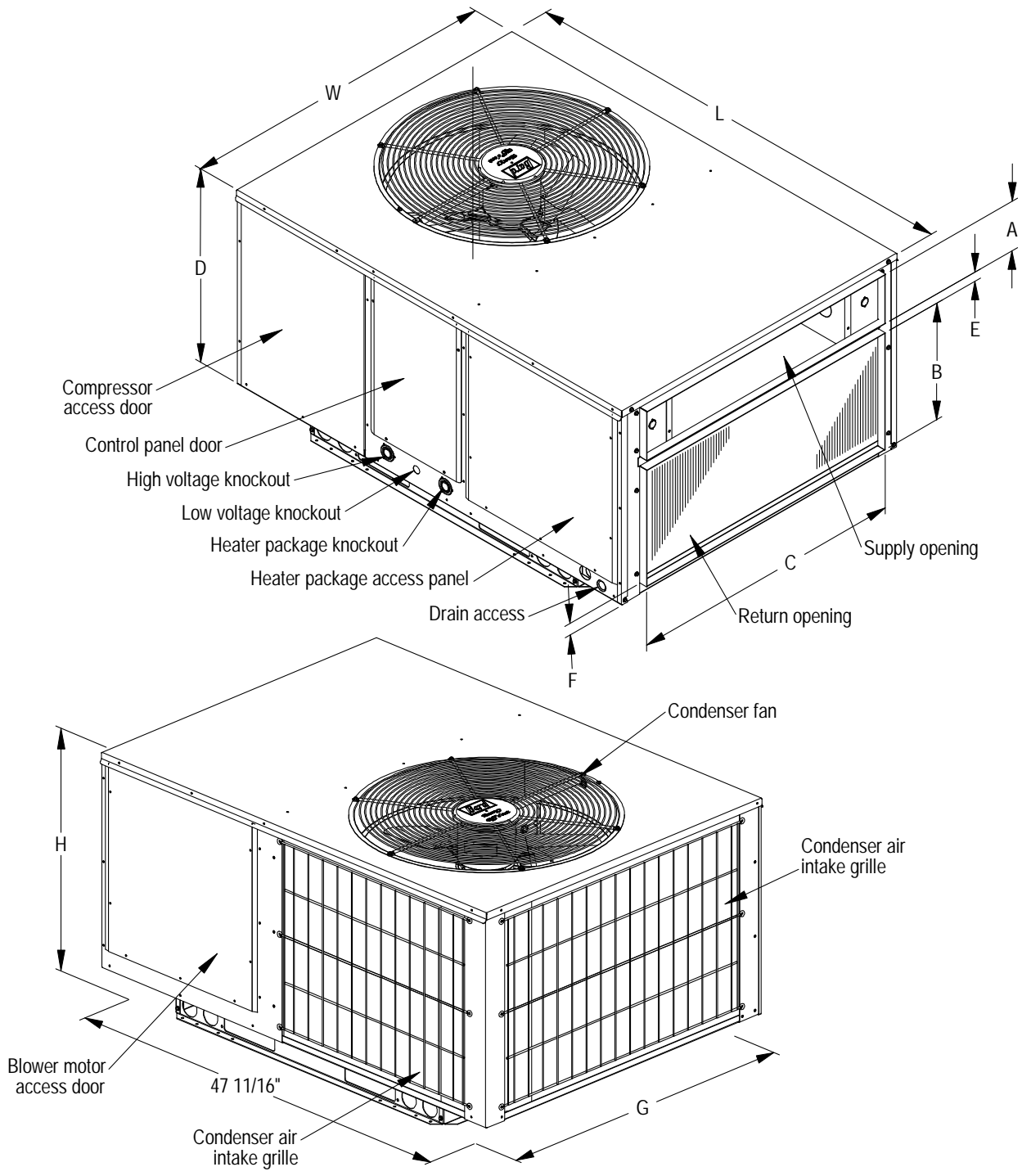

Unit Dimension Chart

Unit	Supply Size		Return Size		Unit Overall Dimensions			Unit General Dimensions			
	A	C	B	C	H (height)	L (length)	W (width)	D	E	F	G
PA/PH1324,1330,1336	5.875	32.875	13.875	32.875	26.25	53.25	38.125	23.25	1.125	1.375	35.625
PA/PH1342,1348,1360	9.875	37.875	15.875	37.875	33.25	55.25	42.375	30.25	1.5	2.375	38.125

MIS-2142 A

**FIGURE 1B
UNIT DIMENSIONAL DRAWING**

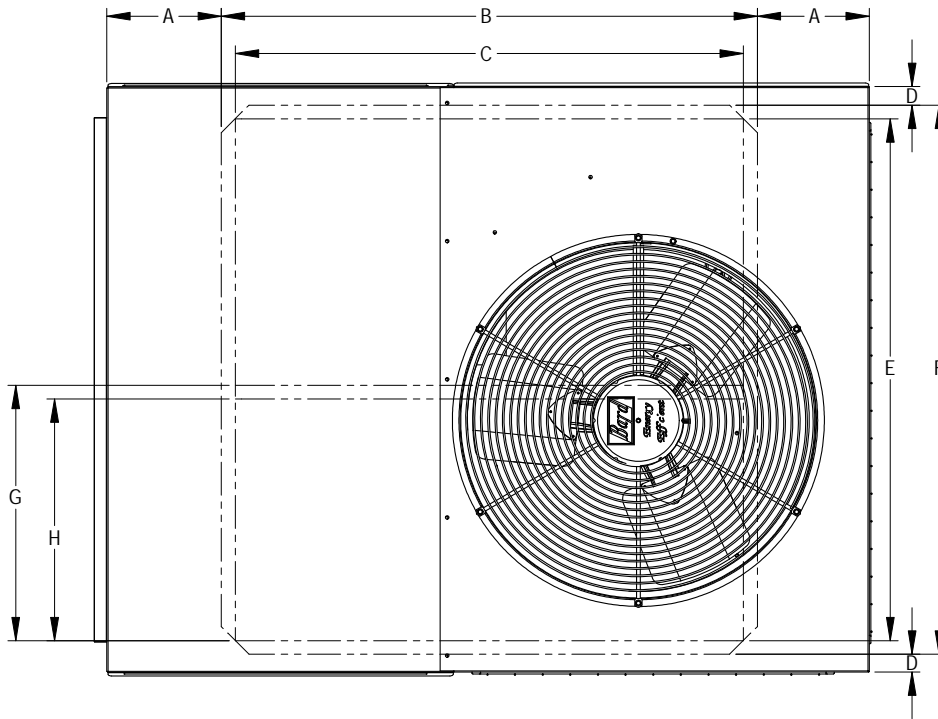

UNIT	A	B	C	D	E	F	G	H
PA/PH1324, 1330, 1336	7 3/16"	38 13/16"	36 3/4"	1 3/8"	33 5/8"	35 1/2"	18 3/16"	17 1/4"
PA/PH1342, 1348, 1360	8 3/16"	39 13/16"	36 3/4"	1 3/8"	37 3/4"	39 3/4"	18 1/2"	17 1/2"

MIS-3033

INSTALLATION

LOCATION

GENERAL

The unit must be located outside, or in a well ventilated area. It must not be in the space being heated or cooled. A sound absorbing material should be considered if the unit is to be installed in such a position or location that might cause transmission of sound or vibration to the living area or adjacent buildings.

SLAB MOUNTING

In areas where winter temperatures *DO NOT* go below 32°F for periods over twelve hours, the unit may be slab mounted at grade level. When installing unit at grade level, install on a concrete slab at least four inches above finished grade level. Slab should have a slope tolerance away from the building structure of at least ¼ inch per foot, while being level from side to side. This will prevent ice buildup under the unit during defrost cycles. Place slab in a location where runoff water from higher ground will not collect around unit. See Figure 2.

A minimum of 24 inches should be provided between the coil inlet and any building surfaces. Provide a minimum of three feet clearance on the service access side of the unit. See Figure 3.

When a unit is installed in areas where low ambient temperatures or strong winter winds exist, it should be placed so prevailing winter winds are not in direct line with the heat pump coil. If this is not possible, a wind barrier should be constructed. Place barrier 24 inches from the coil inlet side of the unit and in the direction of prevailing winds. Size barrier at least the same height and width as the unit. This may be necessary on ground level installations, also. See Figure 3.

WINTER INSTALLATION BELOW 32°F

In areas where winter conditions go below 32°F for extended periods, the unit must be elevated above the mounting surface to prevent snowfall or defrost ice accumulation from interfering with the operation of the unit. A minimum of twelve inch elevation is recommended, while greater elevation may be required for areas of high snow accumulation. Poured concrete, steel framework, brick, cement block, etc., can be utilized to construct a suitable raised mounting platform. See Figure 4.

TYPICAL INSTALLATIONS

1. **ROOF MOUNTED** – The unit is mounted on a sturdy base on the roof of the building. Return air to the unit is brought through a single return grille (grilles with built-in filters are best since they enable easy access for filter changing). Return air ducts are attached to the lower section of the front panel. Supply air is brought from the unit to attic duct work or to a furred down hall. Supply air duct is attached to the top of the front panel.

CAUTION: All outdoor duct work must be thoroughly insulated and weatherproofed. All attic duct work must be thoroughly insulated. Two inch thick insulation with suitable vapor barrier is recommended for both outdoor and attic runs.

In roof top installation, as in all installations, the heat pump must be level from side to side. However, the unit should have a pitch along the length to assure complete external drainage of precipitation and of defrost condensate.

2. **CRAWL SPACE** – Duct work installed in crawl space must be well insulated and provided with a vapor barrier. In addition, the crawl space must be thoroughly ventilated and provided with a good vapor barrier as a ground cover. It is most desirable to install the unit outdoors rather than inside the crawl space, so that it will be readily accessible for service. In addition, it is necessary to dispose of the condensate from the outdoor coil on the heating cycle, and this is virtually impossible with the unit installed inside the crawl space.
3. **SLAB MOUNTED AT GROUND LEVEL** – This type installation is ideal for homes with a slab floor construction where a roof mounted unit is not desired. The supply and return duct work can be run through a furred closet space.
4. **THROUGH THE WALL** – This type installation requires a suitable framework to be fabricated capable of withstanding the unit weight. Normally the unit will be insulated so as to minimize supply and return duct work.

**FIGURE 2
SLAB MOUNTING AT GROUND LEVEL**

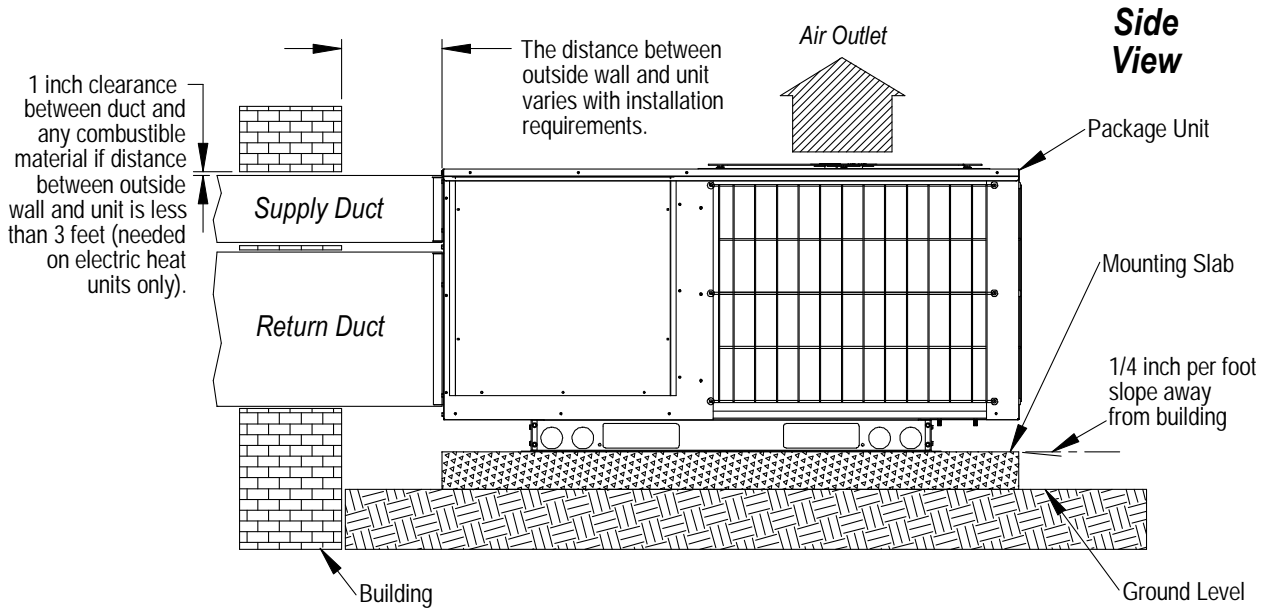

**FIGURE 3
AIRFLOW AND SERVICE ACCESS CLEARANCES**

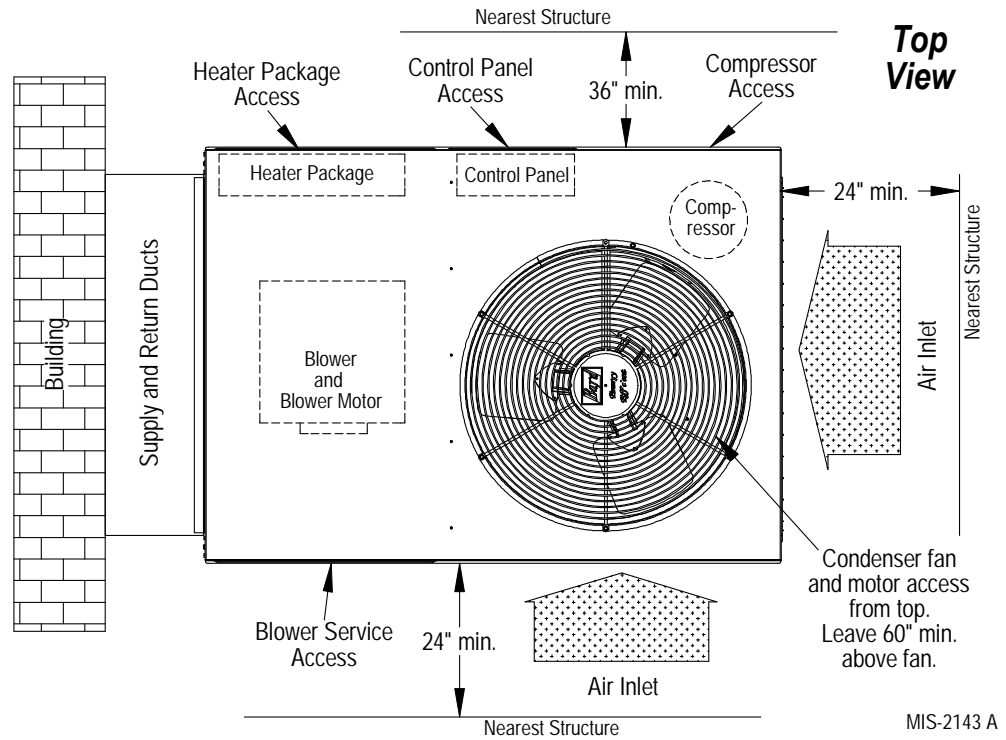

**FIGURE 4
ELEVATED MOUNTING PLATFORMS**

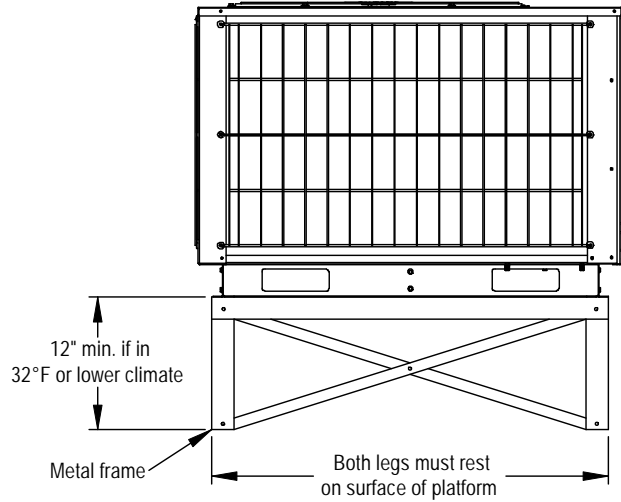
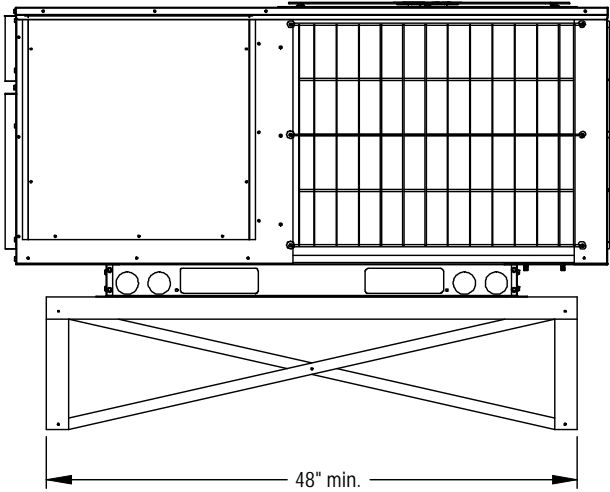
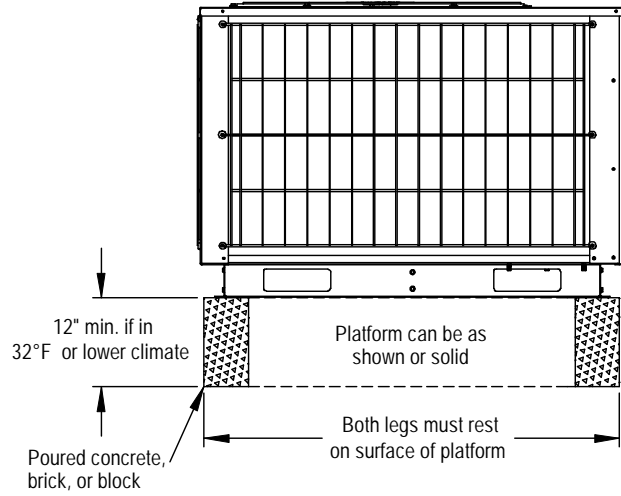
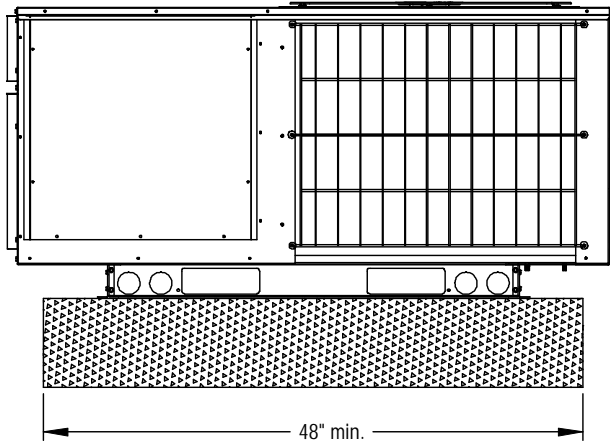

MIS-2144 A

5. **OTHER INSTALLATIONS** – Many other installations are possible with the packaged heat pump. No matter what the installation, always consider the following facts:
- A. Insure that the discharge air is not obstructed in any way so as to cause operation difficulties.
 - B. The indoor coil drain pan is equipped with a coupling that must be piped through a condensate drain trap to a suitable drain.
 - C. Always mount the unit in such a position that it may be easily reached for servicing and maintenance.
 - D. Insure that the unit is clear so that proper air flow over the outdoor coil will be maintained.

If this unit is operated in cooling below a 55° outdoor ambient temperature, the installation of low ambient controls (CMH-15) to unit is required.

CONDENSATE DRAIN TRAP

It is very important to provide a trap in the condensate drain line to allow a positive liquid seal in the line and assure correct drainage from the coil condensate pan.

Install condensate drain trap shown in Figure 5. Use drain connection size or larger. Do not operate unit without trap. Unit must be level or slightly inclined toward drain.

With a trap installed on a unit located in an unconditioned area, water in the trap may freeze. It is recommended that the trap material be of a type that will allow for expansion of water when it freezes.

AIR FILTERS

Air filters for the return air side of the system are not provided as part of the various types of applications for these models, and must be field supplied and installed as part of the final installation.

Prior thought should be given to return air location and placement of the air filter(s). The air filter(s) must be of adequate size and readily accessible to the operator of the equipment. Filters must be adequate in size and properly maintained for proper operation. If this is not done, excessive energy use, poor performance, and multiple service problems will result. *It is impossible to oversize air filters.* Generous sizing will result in cleaner air and coils as well as lower operating costs and extend the time between required changes. Table 5 shows minimum filter areas and recommended filter sizes. Actual filter sizes can vary with the installation due to single or multiple returns utilizing a filter/grille arrangement or being placed immediately ahead of the indoor coil face in the return air duct.

**TABLE 5
FILTERS REQUIRED AND SIZE**

Model No.	Minimum Filter Free Area	Minimum Recommended Size
PH1324 PH1330 PH1336	403 Square Inches (2.8 Square Feet)	(2) 14 x 20 x 1
PH1342 PH1348 PH1360	473 Square Inches (3.3 Square Feet)	(2) 16 x 20 x 1

NOTE: If roof hood accessory is to be used, information on air filters may be found under that heading in this manual. Air filters are supplied as part of that package.

**FIGURE 5
CONDENSATE DRAIN TRAP**

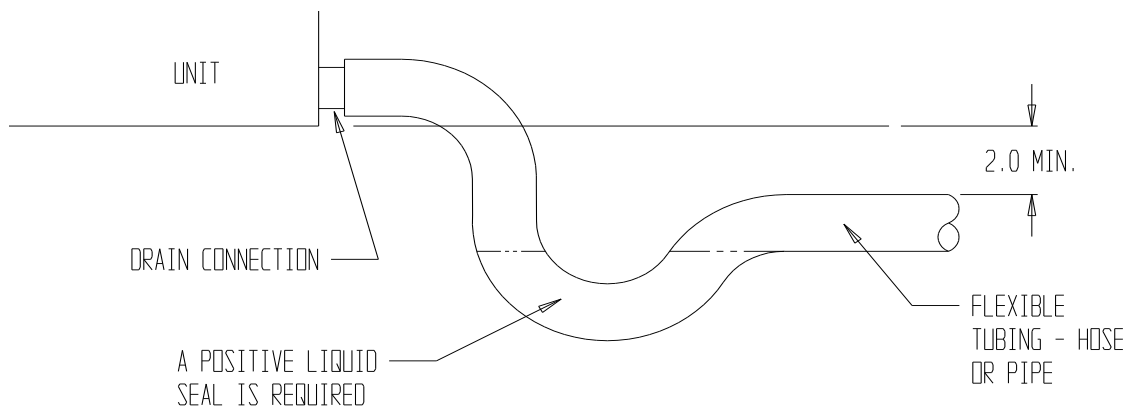

MIS-136

THERMOSTATS

See specific wiring information for the different models, heater KWs, and voltages.

**TABLE 6
HEAT PUMP THERMOSTATS**

Thermostat	Predominant Features
8403-058 (TH5220D1151)	2 stage Cool; 2 stage Heat Electronic Non-Programmable Auto or Manual changeover
8403-060 (1120-445)	3 stage Cool; 3 stage Heat Programmable/Non-Programmable Electronic HP or Conventional Auto or Manual changeover

IMPORTANT NOTE: Only the thermostat and subbase combinations as shown above will work with this equipment. The thermostat and subbase **MUST** be matched, and correct operation can be assured only by proper selection and application of these parts. The above combinations incorporate the following features: Man-Auto fan switch, Off-Heat-Cool-Em. Heat Switch.

NOTE: All thermostats specified maintain the reversing valve energized when switched into heating mode (does not cycle with demand).

**TABLE 7
THERMOSTAT WIRE SIZE**

Transformer VA	FLA	Wire Gauge	Maximum Length in Feet
55	2.3	20	45
		18	60
		16	100
		14	160
		12	250

WIRING – MAIN POWER

Refer to the unit rating plate for wire sizing information and maximum fuse size. Each outdoor unit is marked with a “Minimum Circuit Ampacity”. This means that the field wiring used must be sized to carry that amount of current. If field installed heaters are added to the basic unit, a second separate power supply circuit will be required. The heater rating plate located adjacent to the basic unit rating plate will show the appropriate circuit ampacity fuse size, etc. (Also see “Electrical Data” on pages 5 and 7.) *All models are suitable for connection with copper wire only.* These instructions **must** be adhered to. Refer to the National Electrical Code for complete current carrying capacity data on the various insulation grades of wiring material.

The unit rating plate lists a “Maximum Time Delay Fuse” or “HACR” type circuit breaker that is to be used with the equipment. The correct size must be used for proper circuit protection and also to assure that there will be no nuisance tripping due to the momentary high starting current of the compressor.

WIRING – 24V LOW VOLTAGE CONTROL CIRCUIT

Eight (8) wires should be run from thermostat subbase to the 24V terminal board in the unit. A ten conductor, 18 gauge copper, color-coded thermostat cable is recommended. The connection points are shown in Figure 6.

**FIGURE 6
LOW VOLTAGE WIRING**

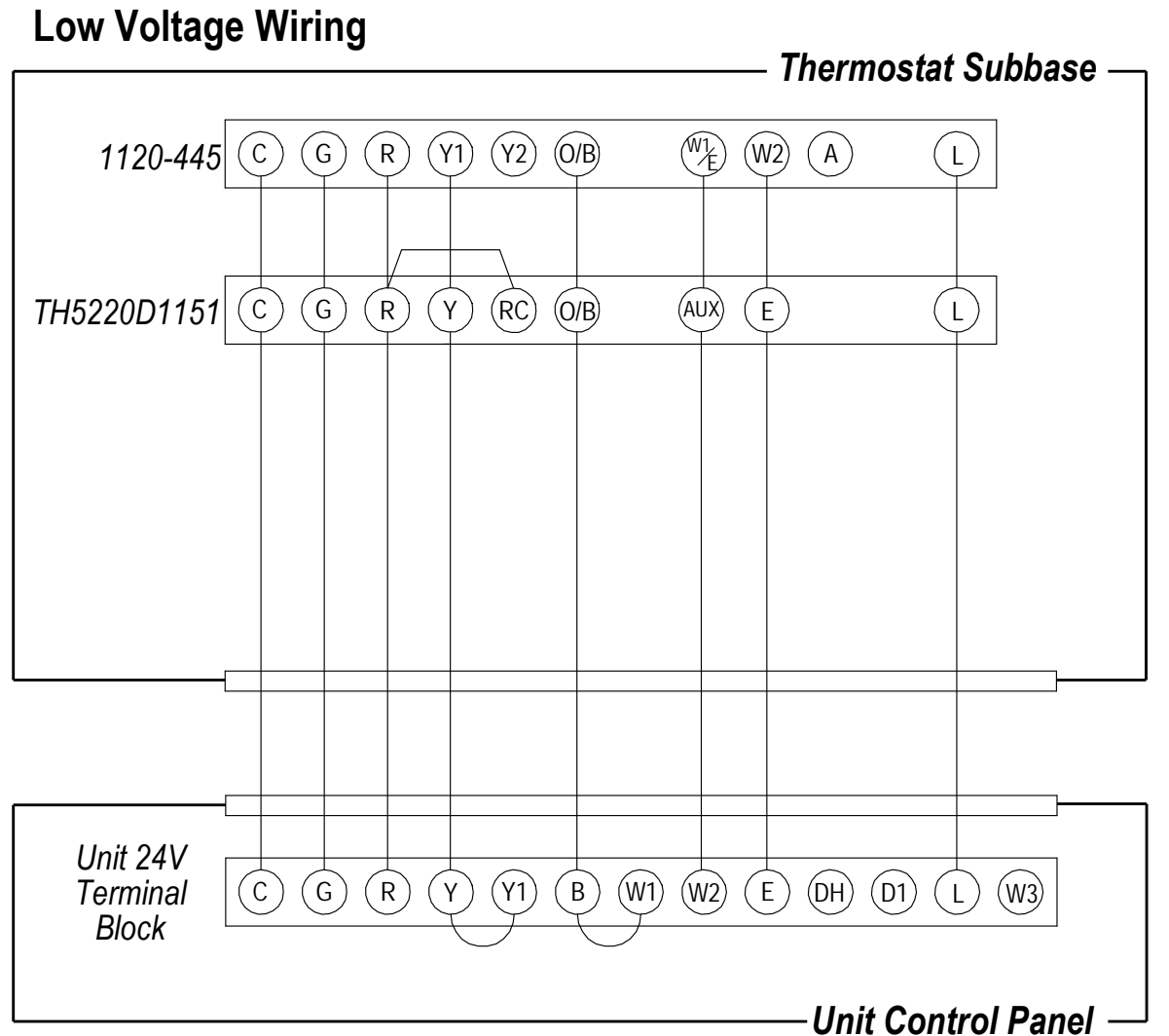

MIS-2150 A

THERMOSTAT INDICATOR LAMPS

The red lamp marked “EM. HT.” comes on and stays on whenever the system switch is placed in Em. Ht. position. The green lamp marked “Check” will come on if there is any problem that prevents the compressor from running when it is supposed to be.

EMERGENCY HEAT POSITION

The operator of the equipment must manually place the system switch in this position. This is done when there is a known problem with the outdoor section, or when the green “Check” lamp comes on indicating a problem.

TRANSFORMER TAPS

230/208V, 1 phase and 3 phase equipment employ dual primary voltage transformers. All equipment leaves the factory wired on 240V tap. For 208V operation, reconnect from 240V to 208V tap. The acceptable operating voltage range for the 240 and 208V taps are:

TAP	RANGE
240	253 – 216
208	220 – 187

NOTE: The voltage should be measured at the field power connection point in the unit and while the unit is operating at full load (maximum amperage operating condition).

COMPRESSOR CUTOFF THERMOSTAT and OUTDOOR THERMOSTAT WIRING

Heat pump compressor operation at outdoor temperatures below 0°F are neither desirable nor advantageous in terms of efficiency. Since most equipment at time of manufacture is not designated for any specific destination of the country and most of the equipment is installed in areas not approaching the lower outdoor temperature range, the compressor cutoffs are not factory installed.

Outdoor thermostats are available to hold off various banks of electric heat until needed as determined by outdoor temperature. The set point of either type of thermostat is variable with geographic region and sizing of the heating equipment to the structure. Utilization of the Heating Application Data and the heat loss calculation of the building are useful in determining the correct set points. Refer to Installation Instructions of CMH-14 Outdoor Thermostat Kit for more information.

FIGURE 7
UNIT 24V TERMINAL BOARD (5 — 10 KW)

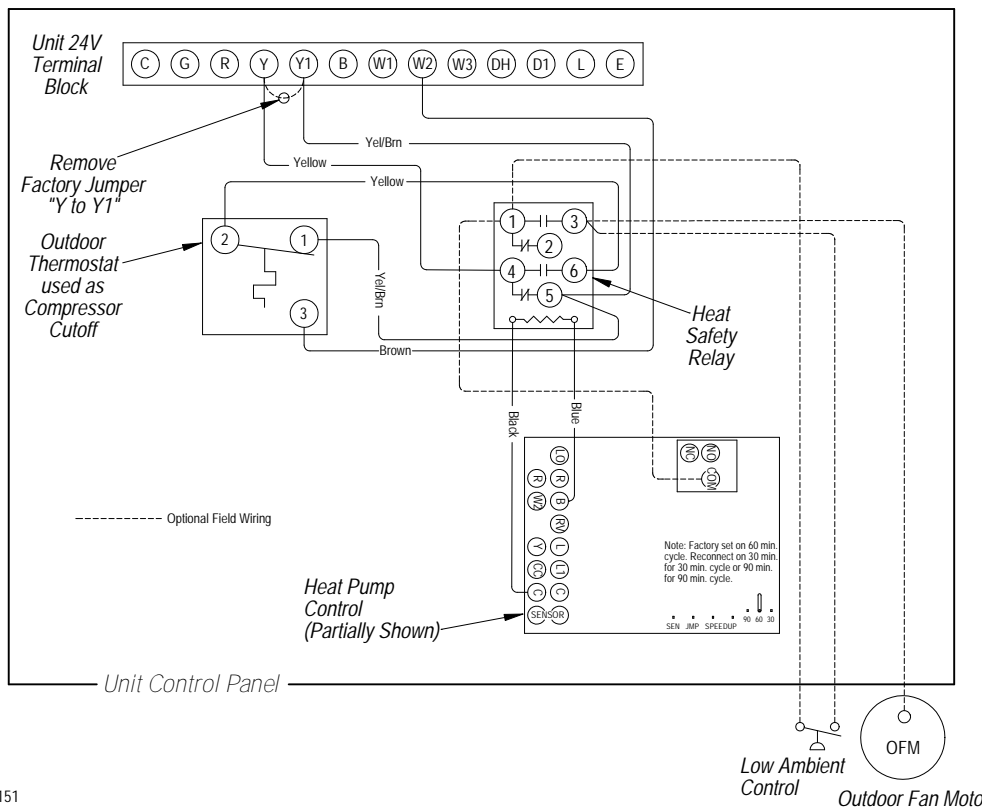

MS-2151

COMPRESSOR CUTOFF THERMOSTAT WIRING (5 — 10 KW) (FIGURE 7)

COMPRESSOR CUTOFF THERMOSTAT WIRING (15 — 20 KW) (FIGURE 8)

TABLE 8
5 — 10 KW

Model	KW	Volts	Phase
PH13242-A	0, 5, 10	230	1
PH13302-A	0, 5, 10	230	1
PH13363-A	0, 5	230	1
PH13363-B	0, 9	230	3
PH13422-A	0, 5, 10	230	1
PH13422-B, -C	0, 9	230/460	3
PH13482-A	0, 5, 10	230	1
PH13482-B, -C	0, 9	230/460	3
PH13602-A	0, 5, 10	230	1
PH13602-B, -C	0, 9	230/460	3

TABLE 9
15 — 20 KW

Model	KW	Volts	Phase
PH13302-A	15	230	1
PH13363-A	15	230	1
PH13363-B	15	230	3
PH13422-A	15	230	1
PH13422-B, -C	15	230/460	3
PH13482-A	15	230	1
PH13482-B, -C	15	230/460	3
PH13602-A	15	230	1
PH13602-B, -C	15	230/460	3

FIGURE 8
UNIT 24V TERMINAL BOARD (15 THROUGH 20 KW)

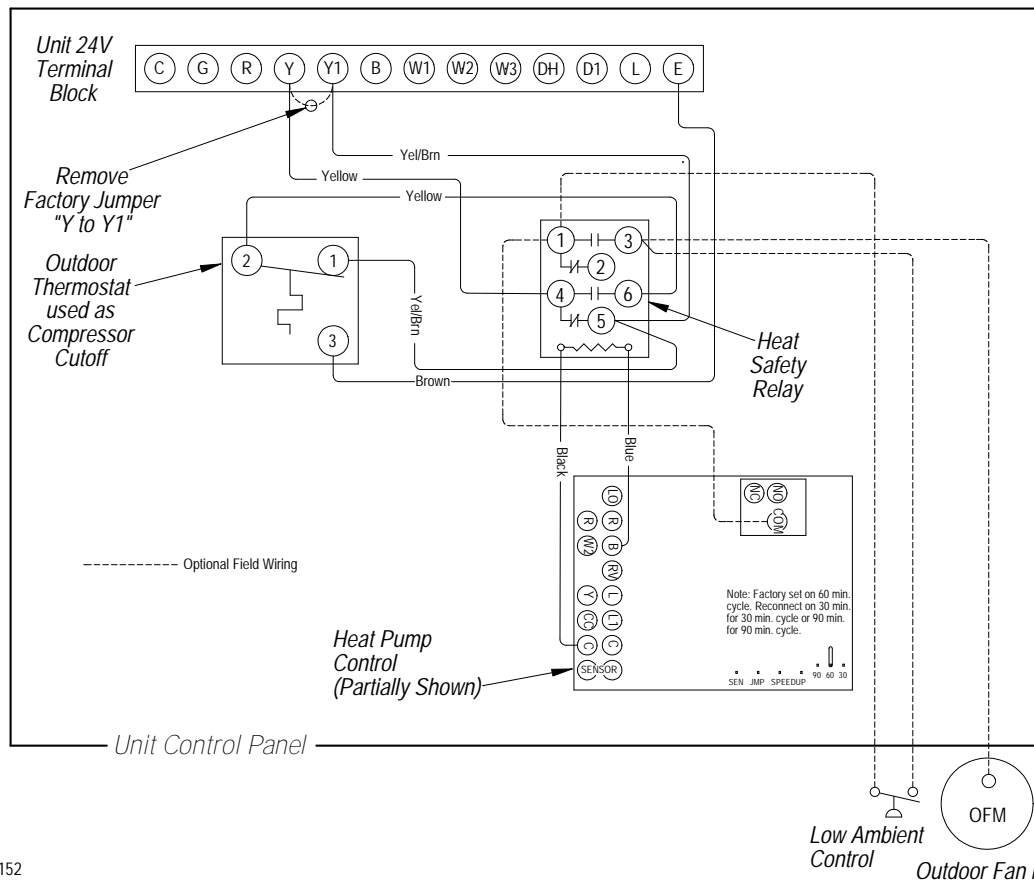

START UP

These units require R-410A refrigerant and Polyol Ester.

GENERAL:

1. Use separate service equipment to avoid cross contamination of oil and refrigerants.
2. Use recovery equipment rated for R-410A refrigerant.
3. Use manifold gauges rated for R-410A (800 psi/250 psi low).
4. R-410A is a binary blend of HFC-32 and HFC-125.
5. R-410A is nearly azeotropic - similar to R-22 and R-12. Although nearly azeotropic, charge with liquid refrigerant.
6. R-410A operates at 40-70% higher pressure than R-22, and systems designed for R-22 cannot withstand this higher pressure.
7. R-410A has an ozone depletion potential of zero, but must be reclaimed due to its global warming potential.
8. R-410A compressors use Polyol Ester.
9. Polyol Ester oil is hygroscopic; it will rapidly absorb moisture and strongly hold this moisture in the oil.
10. A liquid line dryer must be used - even a deep vacuum will not separate moisture from the oil.
11. Limit atmospheric exposure to 15 minutes.
12. If compressor removal is necessary, always plug compressor immediately after removal. Purge with small amount of nitrogen when inserting plugs.

TOPPING OFF SYSTEM CHARGE

If a leak has occurred in the system, Bard Manufacturing recommends reclaiming, evacuating (see criteria above), and charging to the nameplate charge. Topping off the system charge can be done without problems.

With R-410A, there are no significant changes in the refrigerant composition during multiple leaks and recharges. R-410A refrigerant is close to being an azeotropic blend (it behaves like a pure compound or single component refrigerant). The remaining refrigerant charge, in the system, may be used after leaks have occurred and then “top-off” the charge by utilizing the pressure charts on the inner control panel cover as a guideline.

REMEMBER: When adding R-410A refrigerant, it must come out of the charging cylinder/tank as a liquid to avoid any fractionation, and to insure optimal system performance. Refer to instructions for the cylinder that is being utilized for proper method of liquid extraction.

SAFETY PRACTICES:

1. Never mix R-410A with other refrigerants.
2. Use gloves and safety glasses, Polyol Ester oils can be irritating to the skin, and liquid refrigerant will freeze the skin.
3. Never use air and R-410A to leak check; the mixture may become flammable.
4. Do not inhale R-410A – the vapor attacks the nervous system, creating dizziness, loss of coordination and slurred speech. Cardiac irregularities, unconsciousness and ultimate death can result from breathing this concentration.
5. Do not burn R-410A. This decomposition produces hazardous vapors. Evacuate the area if exposed.
6. Use only cylinders rated DOT4BA/4BW 400.
7. Never fill cylinders over 80% of total capacity.
8. Store cylinders in a cool area, out of direct sunlight.
9. Never heat cylinders above 125°F.
10. Never trap liquid R-410A in manifold sets, gauge lines or cylinders. R-410A expands significantly at warmer temperatures. Once a cylinder or line is full of liquid, any further rise in temperature will cause it to burst.

START UP NOTES

For improved start up performance, wash the indoor coil with dishwasher detergent.

START UP AND OPERATION

THREE PHASE SCROLL COMPRESSOR START UP INFORMATION

**(Models PH13363-B, PH13422-B, -C;
PH13482-B, -C; PH13602-B, -C)**

All units with three phase scroll compressors are equipped with a three phase line monitor to prevent compressor damage due to phase reversal.

The phase monitor in this unit is equipped with two LED's. If the "Y" signal is present at the phase monitor and phases are correct, the green LED will light.

If phases are reversed, the red fault LED will be lit and compressor operation is inhibited.

If a fault condition occurs, reverse tow of the supply leads to the unit. Do not reverse any of the unit factory wires as damage may occur.

SEQUENCE OF OPERATION

BLOWER ONLY – When the "Fan" switch on the room thermostat is placed in the "On" position (circuit R-G makes), the blower will energize and run until the "Fan" switch is placed back into the "Auto" position. This will allow for constant air circulation at a lower airflow during times when the unit is not in operation for cooling or heating.

COOLING – On a call for cooling from the room thermostat (circuit R-Y makes), the blower will energize (circuit R-G is automatic when R-Y makes) as well as the compressor, and outdoor fan motor. Note that if the "Fan" switch on the room thermostat is in the "On" position and the blower is already in operation, then the motor will ramp up to the required speed for cooling.

HEATING (1st Stage) – On a call for heating from the room thermostat (circuit R-Y&B makes), the blower will energize (circuit R-G is automatic when R-Y makes) as well as the compressor, outdoor fan motor, and reversing valve solenoid coil. This will place the system into heat pump operation to maintain the thermostat set temperature. Note that if the "Fan" switch on the room thermostat is in the "On" position and the blower is already in operation, then the motor will ramp up to the required speed for heating.

HEATING (1st Stage Defrost) – During the defrost cycle, the heat pump control will energize electric heaters, if installed, (circuit R-W2 makes), allowing room temperature to be maintained during heat pump defrost operation.

HEATING (2nd Stage) – If the operation of the heat pump will not maintain the set room temperature, then the thermostat will call for additional heat from electric heaters to help maintain the set temperature. On a call for second stage heating from the room thermostat (circuit R-W2 makes), backup electric heaters will be energized if installed.

HEATING (Em Heat) – When the room thermostat is placed in the "Em Heat" position (circuit R-E makes), the blower and electric heaters, if installed, will energize on second stage heat (circuit R-W2&W3 makes), with the compressor and outdoor fan motor locked out of operation.

DEFROST CYCLE

The defrost cycle is controlled by temperature and time on the solid state heat pump control.

When the outdoor temperature is in the lower 40°F temperature range or colder, the outdoor coil temperature is 32°F or below. This coil temperature is sensed by the coil temperature sensor mounted near the bottom of the outdoor coil. Once coil temperature reaches 30°F or below, the coil temperature sensor sends a signal to the control logic of the heat pump control and the defrost timer will start accumulating run time.

After 30, 60 or 90 minutes of heat pump operation at 30°F or below, the heat pump control will place the system in the defrost mode.

During the defrost mode, the refrigerant cycle switches back to the cooling cycle, the outdoor motor stops, electric heaters are energized, and hot gas passing through the outdoor coil melts any accumulated frost. When the temperature rises to approximately 57°F, the coil temperature sensor will send a signal to the heat pump control which will return the system to heating operations automatically.

If some abnormal or temporary condition such as a high wind causes the heat pump to have a prolonged defrost cycle, the heat pump control will restore the system to heating operation automatically after 8 minutes.

The heat pump defrost control board has an option of 30, 60 or 90-minute setting. By default, this unit is shipped from the factory with the defrost time on the 60 minute pin. If circumstances require a change to another time, remove the wire from the 60-minute terminal and reconnect to the desired terminal. Refer to Figure 9.

There is a cycle speed up jumper on the control. This can be used for testing purposes to reduce the time between defrost cycle operation without waiting for time to elapse.

Use a small screwdriver or other metallic object, or another ¼ inch QC, to short between the *SPEEDUP* terminals to accelerate the HPC timer and initiate defrost.

Be careful not to touch any other terminals with the instrument used to short the *SPEEDUP* terminals. It may take up to 10 seconds with the *SPEEDUP* terminals shorted for the speedup to be completed and the defrost cycle to start.

As soon as the defrost cycle kicks in remove the shorting instrument from the SPEEDUP terminals. Otherwise the timing will remain accelerated and run through the 1-minute minimum defrost length sequence in a matter of seconds and will automatically terminate the defrost sequence.

**FIGURE 9
DEFROST CONTROL BOARD**

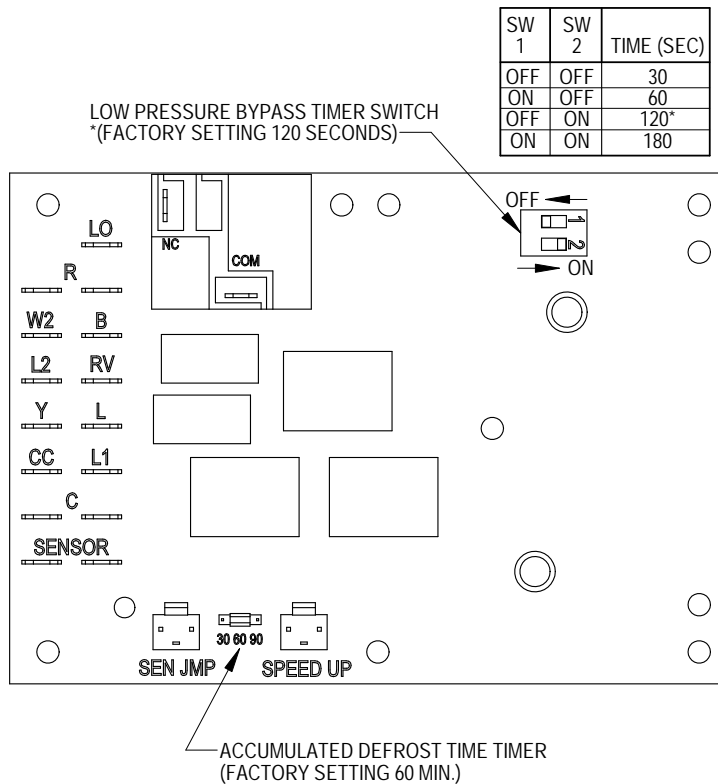

MIS-2668 A

There is an initiate defrost jumper (sen jump) on the control that can be used at any outdoor ambient during the heating cycle to simulate a 0° coil temperature.

This can be used to check defrost operation of the unit without waiting for the outdoor ambient to fall into the defrost region.

By placing a jumper across the *SEN JMP* terminals (a ¼ inch QC terminal works best) the defrost sensor mounted on the outdoor coil is shunted out & will activate the timing circuit. This permits the defrost cycle to be checked out in warmer weather conditions without the outdoor temperature having to fall into the defrost region.

In order to terminate the defrost test the *SEN JMP* jumper must be removed. If left in place too long, the compressor could stop due to the high pressure control opening because of high pressure condition created by operating in the cooling mode with outdoor fan off. Pressure will rise fairly fast as there is likely no actual frost on the outdoor coil in this artificial test condition.

There is also a 5-minute compressor time delay function built into the HPC. This is to protect the compressor from short cycling conditions. The board's LED will have a fast blink rate when in the compressor time delay. In some instances, it is helpful to the service technician to override or speed up this timing period, and shorting out the *SPEEDUP* terminals for a few seconds can do this.

Low Pressure Switch Bypass Operation - The control has a selectable (SW1) low pressure switch bypass set up to ignore

the low pressure switch input during the first (30, 60, 120 or 180 seconds) of "Y" operation.

After this period expires, the control will then monitor the low pressure switch input normally to make sure that the switch is closed during "Y" operation.

High Pressure Switch Operation - The control has a built-in lockout system that allows the unit to have the high pressure switch trip up to two times in one hour and only encounter a "soft" lockout. A "soft" lockout shuts the compressor off and waits for the pressure switch to reset, which at that point then allows the compressor to be restarted as long as the 5-minute short cycle timer has run out. If the high pressure switch trips a third time within one hour, the unit is in "hard" lockout indicating something is certainly wrong and it will not restart itself.

TROUBLESHOOTING

SOLID STATE HEAT PUMP CONTROL TROUBLESHOOTING PROCEDURE

- NOTE:** A thorough understanding of the defrost cycle sequence is essential. Review that section earlier in this manual prior to troubleshooting the control. Turn on AC power supply to unit.
- Turn thermostat blower switch to “fan on” – the indoor blower should start. (If it doesn’t, troubleshoot indoor unit and correct problem.)
- Turn thermostat blower to “auto” position. Indoor blower should stop. **NOTE:** Many models have a 1-minute blower time delay on “off” command; wait for this to time-out.
- Set system switch to “heat” or “cool”. Adjust thermostat to call for heat or cool. The indoor blower, compressor and outdoor fan should start.

NOTE: If there was no power to 24 volt transformer, the compressor and outdoor fan motor will not start for 5 minutes. This is because of the compressor short cycle protection.

LED BLINK CODES

BLINK	FUNCTION
Slow	Normal function (1.0 sec on/1.0 sec off)
Fast	Comp. Delay timer active (0.1 sec on/0.1 sec off)
1	Low pressure switch failure
2	High pressure switch failure/“Soft” Lockout
3	Defrost mode active
4	High pressure switch failure/“Hard” Lockout

**TABLE 10
TROUBLESHOOTING**

Symptom	Description, Check & Possible Causes	What & How to Check / Repair
Compressor will not start (heating or cooling)	1. Check for LED illumination. Is there an LED illuminated on the board (flashing)?	Yes = go to Step #2; No = go to Step #3
	2. Check for error codes. Is the LED flashing a Code?	Yes = go to Step #4; No = go to Step #8
	3. Check for power at board. Is there 24 volts AC between R and C?	Yes = go to Step #13; No = go to Step #9
	4. Check codes. What code is blinking?	Code “1”, go to Step #6; Code “2”, go to Step#7; Fast Blink, go to Step #5
	5. Compressor delay active. Wait for 5 minute delay or jump board’s “speed up pins”.	Check for proper operation; if still needed, go back to Step #1.
	6. Low pressure fault.	Check wiring circuit and unit pressures.
	7. High pressure fault.	Check wiring circuit and unit pressures.
	8. Check for Compressor input signal. Is there 24 volts AC between Y and C?	Yes = go to Step #10; No = go to Step #11
	9. No power to board.	The unit either does not have unit voltage, the transformer is bad or the unit wiring is incorrect.
	10. Check for Compressor output signal. Is there 24 volts AC between CC & C?	Yes = go to Step #12; No = go to Step #13
	11. No “Y” compressor input signal.	Check thermostat wiring, incorrect phase of unit (see section on Phase Monitor), and finally unit wiring.
	12. No “CC” compressor output signal.	Check compressor contactor for proper operation and finally check compressor.
	13. Faulty board.	Replace defrost board.
Fan outdoor motor does not run (cooling or heating except during defrost)	Heat pump control defective	Check across fan relay on heat pump control. (Com-NC) Replace heat pump control.
	Motor defective	Check for open or shorted motor winding. Replace motor.
	Motor capacitor defective	Check capacitor rating. Check for open or shorted capacitor. Replace capacitor.
Reversing valve does not energize (heating only)	Heat pump control defective	Check for 24V between RV-C and B-C. 1. Check control circuit wiring. 2. Replace heat pump control.
	Reversing valve solenoid coil defective	Check for open or shorted coil. Replace solenoid coil.
Unit will not go into defrost (heating only)	Temperature sensor or heat pump control defective	Disconnect temperature sensor from board and jumper across “SPEEDUP” terminals and “SEN JMP” terminals. This should cause the unit to go through a defrost cycle within one minute. 1. If unit goes through defrost cycle, replace temperature sensor. 2. If unit does not go through defrost cycle, replace heat pump control.
Unit will not come out of defrost (heating only)	Temperature sensor or heat pump control defective	Jumper across “SPEEDUP” terminal. This should cause the unit to come out of defrost within one minute. 1. If unit comes out of defrost cycle, replace temperature sensor. 2. If unit does not come out of defrost cycle, replace heat pump control.

CHECKING TEMPERATURE SENSOR CHECK OUT

1. Disconnect temperature sensor from board and from outdoor coil.
2. Use an ohmmeter and measure the resistance of the sensor. Also use ohmmeter to check for short or open.
3. Check resistance reading to chart of resistance; use sensor ambient temperature. (Tolerance of part is $\pm 10\%$.)
4. If sensor resistance reads very low, then sensor is shorted and will not allow proper operation of the heat pump control.
5. If sensor is out of tolerance, shorted, open, or reads very low ohms then it should be replaced.

TEMPERATURE F VS RESISTANCE R OF TEMPERATURE SENSOR

F	R	F	R	F	R	F	R
-25.0	196871	13.0	56985	51.0	19374	89.0	7507
-24.0	190099	14.0	55284	52.0	18867	90.0	7334
-23.0	183585	15.0	53640	53.0	18375	91.0	7165
-22.0	177318	16.0	52051	54.0	17989	92.0	7000
-21.0	171289	17.0	50514	55.0	17434	93.0	6840
-20.0	165487	18.0	49028	56.0	16984	94.0	6683
-19.0	159904	19.0	47590	57.0	16547	95.0	6531
-18.0	154529	20.0	46200	58.0	16122	96.0	6383
-17.0	149355	21.0	44855	59.0	15710	97.0	6239
-16.0	144374	22.0	43554	60.0	15310	98.0	6098
-15.0	139576	23.0	42295	61.0	14921	99.0	5961
-14.0	134956	24.0	41077	62.0	14544	100.0	5827
-13.0	130506	25.0	39898	63.0	14177	101.0	5697
-12.0	126219	26.0	38757	64.0	13820	102.0	5570
-11.0	122089	27.0	37652	65.0	13474	103.0	5446
-10.0	118108	28.0	36583	66.0	13137	104.0	5326
-9.0	114272	29.0	35548	67.0	12810	105.0	5208
-8.0	110575	30.0	34545	68.0	12492	106.0	5094
-7.0	107010	31.0	33574	69.0	12183	107.0	4982
-6.0	103574	32.0	32634	70.0	11883	108.0	4873
-5.0	100260	33.0	31723	71.0	11591	109.0	4767
-4.0	97064	34.0	30840	72.0	11307	110.0	4663
-3.0	93981	35.0	29986	73.0	11031	111.0	4562
-2.0	91008	36.0	29157	74.0	10762	112.0	4464
-1.0	88139	37.0	28355	75.0	10501	113.0	4367
0.0	85371	38.0	27577	76.0	10247	114.0	4274
1.0	82699	39.0	26823	77.0	10000	115.0	4182
2.0	80121	40.0	26092	78.0	9760	116.0	4093
3.0	77632	41.0	25383	79.0	9526	117.0	4006
4.0	75230	42.0	24696	80.0	9299	118.0	3921
5.0	72910	43.0	24030	81.0	9077	119.0	3838
6.0	70670	44.0	23384	82.0	8862	120.0	3757
7.0	68507	45.0	22758	83.0	8653	121.0	3678
8.0	66418	46.0	22150	84.0	8449	122.0	3601
9.0	64399	47.0	21561	85.0	8250	123.0	3526
10.0	62449	48.0	20989	86.0	8057	124.0	3452
11.0	60565	49.0	20435	87.0	7869		
12.0	58745	50.0	19896	88.0	7686		

SERVICE HINTS

1. Caution homeowner to maintain clean air filters at all times. Also, not to needlessly close off supply and return air registers. This reduces airflow through the system which shortens equipment service life as well as increasing operating costs.
2. Switching to heating cycle at 75°F or higher outside temperature may cause a nuisance trip of the high pressure switch.
3. The heat pump wall thermostats perform multiple functions. Be sure that all function switches are correctly set for the desired operating mode before trying to diagnose any reported service problems.
4. Check all power fuses or circuit breakers to be sure that they are the correct rating.
5. Periodic cleaning of the outdoor coil to permit full and unrestricted airflow circulation is essential.

PRESSURE SERVICE PORTS

High and low pressure service ports are installed on all units so that the system operating pressures can be observed. Pressure tables can be found in Tables 11 & 12 in this manual covering all models on both cooling and heating cycles. It is imperative to match the correct pressure table to the unit by model number.

R-410A

REFRIGERANT CHARGE

This unit was charged at the factory with the quantity of refrigerant listed on the serial plate. AHRI capacity and efficiency ratings were determined by testing with this refrigerant charge quantity.

The following pressure tables show nominal pressures for the units. Since many installation specific situations can affect the pressure readings, this information should only be used by certified technicians as a guide for evaluating proper system performance. They shall not be used to adjust charge. If charge is in doubt, reclaim, evacuate and recharge the unit to the serial plate charge.

FAN BLADE SETTINGS

Shown in Figure 10 are the correct fan blade setting dimensions for proper air delivery across the outdoor coil.

Any service work requiring removal or adjustment in the fan and/or motor area will require that the dimensions be checked and blade adjusted in or out on the motor shaft accordingly.

**FIGURE 10
FAN BLADE SETTING**

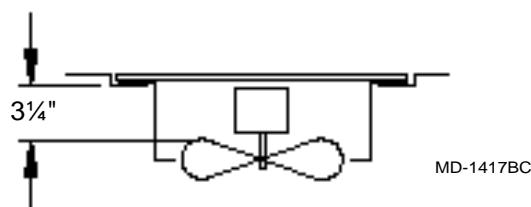

**TABLE 11
PRESSURE TABLE**

Air Temperature Entering Outdoor Coil Degree F

COOLING

Model	Return Air Temperature	Pressure	65°	70°	75°	80°	85°	90°	95°	100°	105°	110°	115°	120°	125°
	75° DB	Low Side	127	128	130	131	132	133	135	136	137	138	139	140	141
	62° WB	High Side	238	262	285	309	333	357	380	410	440	470	500	529	559
PH1324	80° DB	Low Side	136	137	139	140	141	143	144	145	146	148	149	150	151
	67° WB	High Side	244	268	293	317	341	366	384	421	451	482	512	543	574
	85° DB	Low Side	146	148	149	151	152	153	155	156	157	159	160	161	163
	72° WB	High Side	253	278	303	328	353	378	404	435	467	499	530	562	594
	75° DB	Low Side	128	129	131	132	133	134	136	137	138	140	141	142	143
	62° WB	High Side	246	269	292	315	338	361	384	410	435	460	486	511	536
PH1330	80° DB	Low Side	137	138	140	141	142	144	145	146	148	149	151	152	153
	67° WB	High Side	252	276	299	323	347	370	403	420	446	472	498	524	550
	85° DB	Low Side	147	149	150	152	153	154	156	157	159	160	162	163	165
	72° WB	High Side	261	285	310	334	359	383	408	435	462	489	515	542	569
	75° DB	Low Side	122	124	126	127	129	130	132	133	133	134	135	136	136
	62° WB	High Side	248	273	298	324	349	374	400	429	459	488	518	547	576
PH1336	80° DB	Low Side	131	133	134	136	138	139	139	142	143	143	144	145	146
	67° WB	High Side	254	280	306	332	358	384	414	440	470	501	531	561	591
	85° DB	Low Side	141	143	144	146	148	150	152	152	153	154	155	156	157
	72° WB	High Side	263	290	317	344	371	397	424	456	487	518	549	581	612

HEATING

Air Temperature Entering Outdoor Coil Degree F

Model	Return Air Temperature	Pressure	0°	5°	10°	15°	20°	25°	30°	35°	40°	45°	50°	55°	60°
PH1324	70° DB	Low Side	33	40	46	53	60	66	73	80	86	93	100	106	113
		High Side	243	249	256	263	270	277	284	290	297	304	311	318	325
PH1330	70° DB	Low Side	32	39	47	54	61	69	76	83	91	98	105	113	120
		High Side	283	293	304	314	324	335	345	366	376	386	397	407	
PH1336	70° DB	Low Side	35	42	49	56	63	70	77	84	91	98	105	112	119
		High Side	306	316	327	337	347	358	368	378	389	399	409	420	430

LOW SIDE PRESSURE ±4 PSIG
HIGH SIDE PRESSURE ±10 PSIG

Tables based upon rated CFM (airflow) across the evaporator coil.

If incorrect charge suspected (more than ±4 psig suction, ±10 psig liquid),

it is recommended refrigerant charge be reclaimed, system evacuated and charged to serial plate quantity.

**TABLE 12
PRESSURE TABLE**

Air Temperature Entering Outdoor Coil Degree F

COOLING

Model	Return Air Temperature	Pressure	65°	70°	75°	80°	85°	90°	95°	100°	105°	110°	115°	120°	125°
PH1342	75° DB	Low Side	128	129	131	132	133	134	136	136	137	137	138	138	139
	62° WB	High Side	240	263	287	310	333	357	380	409	438	466	495	524	552
PH1348	80° DB	Low Side	137	138	140	141	142	144	145	146	146	147	147	148	149
	67° WB	High Side	246	270	294	318	342	366	402	419	449	478	508	537	566
PH1348	85° DB	Low Side	147	149	150	152	153	154	156	157	157	158	158	159	160
	72° WB	High Side	255	279	304	329	354	379	404	434	465	495	525	556	586
PH1360	75° DB	Low Side	127	128	130	131	132	133	135	135	136	136	137	137	138
	62° WB	High Side	245	267	290	313	336	358	381	411	441	471	501	530	560
PH1360	80° DB	Low Side	136	137	139	140	141	143	144	145	145	146	146	147	148
	67° WB	High Side	251	274	298	321	344	368	418	422	452	483	513	544	575
PH1360	85° DB	Low Side	146	148	149	151	152	153	155	155	156	157	157	158	159
	72° WB	High Side	260	284	308	332	356	381	405	436	468	500	531	563	595
PH1360	75° DB	Low Side	122	122	123	124	125	126	127	128	129	131	132	133	
	62° WB	High Side	245	268	291	314	337	360	383	413	442	472	501	530	
PH1360	80° DB	Low Side	130	131	132	133	134	135	137	137	138	140	141	142	
	67° WB	High Side	251	275	298	322	346	369	423	430	453	484	514	544	
PH1360	85° DB	Low Side	140	141	142	143	144	145	146	147	149	150	151	153	
	72° WB	High Side	260	284	309	333	358	382	407	438	469	501	532	563	

HEATING

Air Temperature Entering Outdoor Coil Degree F

Model	Return Air Temperature	Pressure	0°	5°	10°	15°	20°	25°	30°	35°	40°	45°	50°	55°	60°
PH1342	70° DB	Low Side	34.5	42	49	56	63	70	77.5	85	92	99	106	113	121
		High Side	280	289	298	307	316	325	335	344	353	362	371	380	390
PH1348	70° DB	Low Side	33	40	47	54	61	68	76	83	90	97	104	111	119
		High Side	269	277	286	295	304	313	322	330	339	348	357	366	375
PH1360	70° DB	Low Side	29	36	43	50	57	64	72	79	86	93	100	107	115
		High Side	253	261	268	276	284	291	299	307	314	322	330	337	345

LOW SIDE PRESSURE ±4 PSIG
HIGH SIDE PRESSURE ±10 PSIG

Tables based upon rated CFM (airflow) across the evaporator coil.

If incorrect charge suspected (more than ±4 psig suction, ±10 psig liquid),

it is recommended refrigerant charge be reclaimed, system evacuated and charged to serial plate quantity.

SUCTION AND DISCHARGE TUBE BRAZING

Compliant Scroll compressors have copper plated steel suction and discharge tubes. These tubes are far more rugged and less prone to leaks than copper tubes used on other compressors. Due to different thermal properties of steel and copper, brazing procedures may have to be changed from those commonly used.

- To disconnect: heat joint Areas 2 and 3 slowly and uniformly until braze material softens and the tube can be pulled out of suction fitting. (See Figure 11.)
- To connect:
 - Recommended brazing materials: silfos with minimum 5% silver or silver braze material with flux.

- Reinsert tube into fitting.
- Heat tube uniformly in Area 1 moving slowly to Area 2. When joint reaches brazing temperature, apply brazing material. (See Figure 11.)
- Heat joint uniformly around the circumference to flow braze material completely around the joint.
- Slowly move torch into Area 3 to draw braze material into joint. (See Figure 11.)
- **Do not** overheat joint.

**FIGURE 11
BRAZING DIAGRAM**

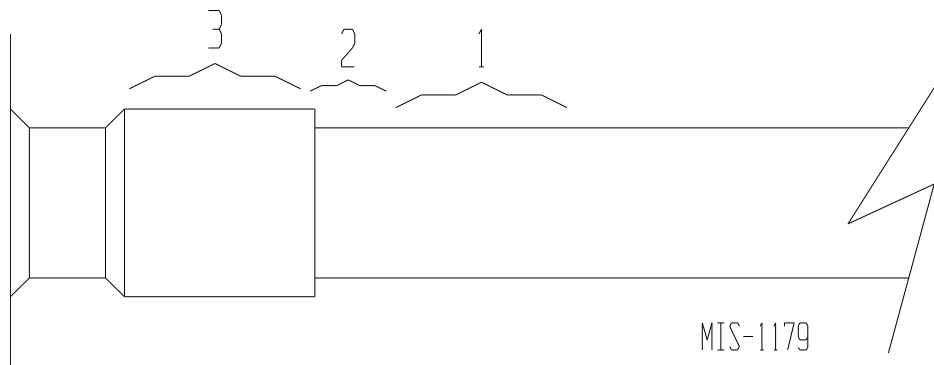

**TABLE 13
INDOOR BLOWER PERFORMANCE ①**

Model	Rated ESP	MAX ESP	② Continuous Airflow	③ Rated Cooling CFM	④ Rated Heating CFM
PH1324	0.10	0.50	600	800	800
PH1330	0.15	0.50	750	1000	1000
PH1336	0.15	0.50	825	1100	1100
PH1342	0.20	0.50	925	1400	1400
PH1348	0.20	0.50	1025	1550	1550
PH1360	0.20	0.50	1150	1750	1750

① Motor will deliver consistent CFM through voltage supply range with no deterioration (197-253V for all 230/208V models).

② Continuous CFM is the total air being circulated during continuous (manual fan) mode.

③ Will occur automatically with a call for "Y" for cooling mode operation.

④ Will occur automatically with a call for "W1" for heating mode operation.

TROUBLESHOOTING GE X13-SERIES ECM2.3™ MOTORS

NOTE: Bard Models PH13242; PH13302; PH13363-A, -B; PH13422-A, -B, -C; PH13482-A, -B, -C; PH13602-A, -B, -C contain the X13-Series Motors.

If the Motor is Running

1. It is normal for the motor to rock back and forth on start up. Do not replace the motor if this is the only problem identified.
2. If the system is excessively noisy, does not appear to change speeds in response to a demand (Heat, Cool, Other), or is having symptoms during the cycle such as tripping limit or freezing coil, check the following:
 - a. Wait for programmed delays to time out.
 - b. Ensure that the motors control inputs are wired to the factory supplied wiring diagram to insure motor is getting proper control signals and sequencing.
 - c. Remove the filter and check that all dampers, registers, and grilles are open and free flowing. If removing the filters corrects the problem, clean or replace with a less restrictive filter. Also check and clean the blower wheel or coil as necessary.
 - d. Check the external static pressure (total of both supply and return) to insure that you are within the ranges as listed on the unit serial plate. If higher than allowed, additional duct work is needed.

- e. If the motor does not shut off at the end of the cycle, wait for any programmed delays to time out (no more than 90 seconds). Also make sure that there is no call for "Continuous Fan" on the "G" terminal.
- f. If the above diagnostics do not solve the problem, confirm the voltage checks in the next section below, then continue with the "Model X13 Communication Diagnostics".

If the Motor is Not Running

1. Check for proper high voltage and ground at the (L/L1) (G) (N/L2) connections at the motor (see Figure 12). Correct any voltage issues before proceeding to the next step. The X13 Motor is voltage specific. Only the correct voltage should be applied to the proper motor. Input voltage within plus or minus 10% of the nominal 230 VAC is acceptable.
2. If the motor has proper high voltage and ground at the (L/L1) (G) (N/L2) connections, then continue with the "Model X13 Communication Diagnostics".

FIGURE 12

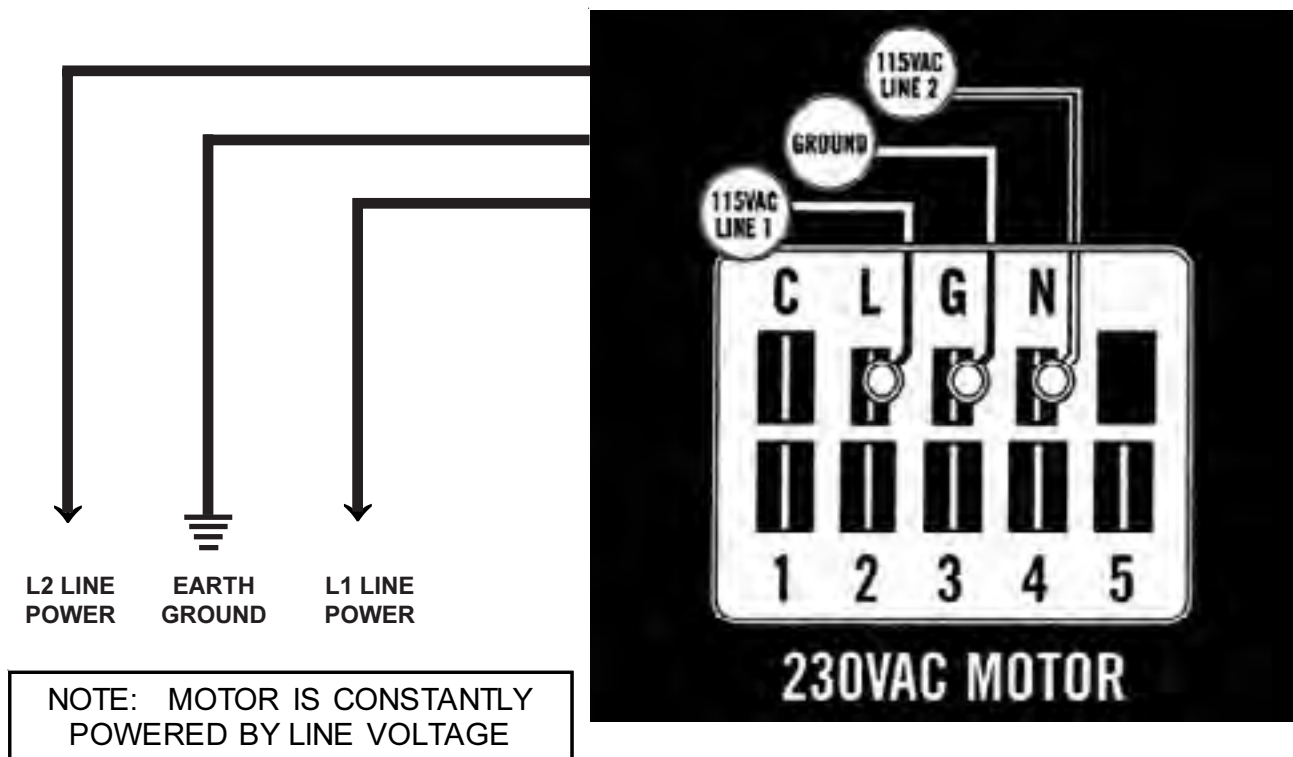

TROUBLESHOOTING GE X13-SERIES ECM2.3™ MOTORS CONT'D.

Model X13 Communication Diagnostics

The X13 motor is communicated through 24 VAC low voltage (Thermostat Control Circuit Wiring).

1. Start with unit wiring diagram to confirm proper connections and voltage (see Figure 13).
2. Initiate a demand from the thermostat and check the voltage between the common and the appropriate motor terminal (1-5). ("G" input is typically on terminal #1, but refer to wiring diagram!)
 - a. If the low voltage communication is not present, check the demand from the thermostat. Also check the output terminal and wire(s) from the terminal strip or control relay(s) to the motor.
 - b. If the motor has proper high voltage as identified above (Motor not Running #1), and proper low voltage to a programmed terminal, and is not operating, the motor is failed, and will require replacement.

FIGURE 13

